

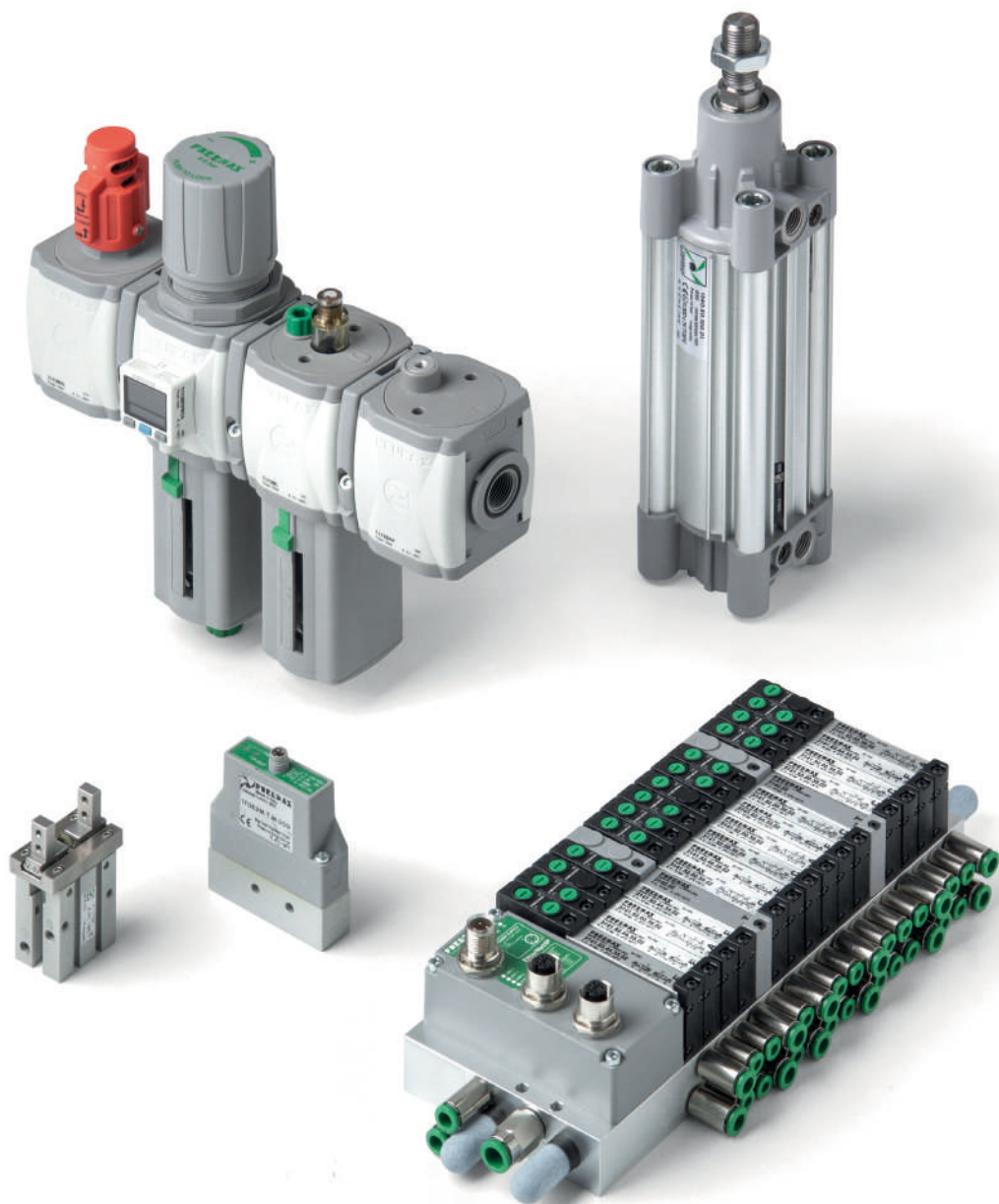

**PNEUMAX**



**GENERAL CATALOGUE** **2021**  
SOLUTIONS FOR PNEUMATIC AUTOMATION



# General catalogue

## Solutions for pneumatic automation

This catalogue includes  
the product range manufactured by  
Pneumax Industrial Automation Business Unit:  
air service units and  
pneumatic components  
for air distribution and motion control.

Further documentation is available on our website [www.pneumaxspa.com](http://www.pneumaxspa.com)  
with reference to **Vacuum Technology, Fittings, Electric Actuation**  
and general catalogues which include the product range offered  
by **Automotive and Process Automation Business Units.**



# General index

## Solutions for pneumatic automation

### Introduction

### About Pneumax

12

### Section 01

### Air distribution

### Valves and solenoid valves



#### Spool valves and solenoid valves

Single and manifold versions, mechanical and manual or pneumatic command

Series 104	1.1	Series 800	1.68	Series 2100 Line-Flat-Base	1.123
Series 105	1.12	Series 888	1.77	Series 2400 Line-Flat-VDMA	1.139
Series 200	1.21	Series 400	1.90	Series 2600 Line-Flat-VDMA	1.162
Series T200	1.54	Series T400	1.109		



#### Direct operated solenoid valves

Pilot valves, high flow rate performance 2/2 ways and 3/2 ways, version miniaturized available as well

Series 300	1.178	Series CNOMO	1.201	UL solenoid coils	1.206
Solenoid coils	1.193	Series S	1.204		
Series M (mechanical)	1.196	300-UL solenoid coils	1.206		



#### Poppet valves and solenoid valves

3/2 & 2/2 valves and solenoid valves for compressed air and vacuum, with aluminium and technopolymer body. 2/2 pad valves, shutter seating inclined solenoid valves for fluids

Series 700	1.208	Series T771	1.241	Series PVF	1.282
Series N776	1.221	Series PVA	1.249		
Series T772-773	1.226	Series F300	1.253		



#### “Namur” valves and solenoid valves

Namur valves and solenoid valves according to standard ISO 5599/1 available in 3 sizes with M12 5/2, 5/3 connectors, aluminium and technopolymer body

Series 514/N	1.283	Series 514	1.290	Series 515	1.297
Series T514	1.285				



### ISO 5599/1 valves and solenoid valves

Valves and solenoid valves according to standard ISO 5599/1 available in 3 sizes with M12 5/2, 5/3 connectors, aluminium and technopolymer body

Series 1000	1.303	Series 1000-M12	1.320
-------------	-------	-----------------	-------

## Accessories

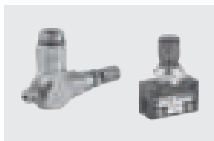

### Pneumatic circuit accessories

Flow control valves, quick exhaust valves, selectors, silencers, unidirectional valves, manifolds, blocking valves, economizers, gang mounting manifolds, spray valves

Series 600	1.327
------------	-------



### Complementary valves

Pressure switches, impulse generators, timers, two hands safety valve, oscillator valve, signal amplifier, progressive start up valve, high-low pressure device

Series 900	1.341
------------	-------



### Blocking valves

Unidirectional and bidirectional blocking valves, aluminium and technopolymer versions, with G1/8" - G1/4" - G3/8" - G1/2" connections

Series 50-T50	1.349
---------------	-------

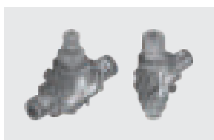

### Function fittings

Miniaturized logic function with technopolymer body:  
RFU, RP, VB, VSR, VS-or, VS-and, IP, AP, RP+IP, VB+RFU, VB+VSR

Series 55-TecnoFUN	1.354
--------------------	-------

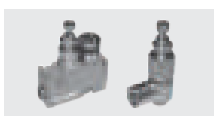

### Miniaturised pressure regulators

Brass versions rod G1/8" & with technopolymer body and integrated gauge version

Series 1750 - 1760	1.369
--------------------	-------



### Compact fittings for lubrication

Nichel plated brass compact fittings, with straight male adaptor

Series Mini-RAP	1.371
-----------------	-------

## Valves and solenoid valve manifolds



Wide range of multipolar & serial system, available with main fieldbus protocol

Series 2700 - ISO15407-2	1.373	Series 2200 Optyma-Sc	1.448	Series 2500 Optyma-T	1.486
Series 2300 Enova	1.400	Series 2500 Optyma-F	1.455	Series 3000	1.520
Series 2200 Optyma-S	1.421				

## Section 02 Air treatment



### Air service units

Wide range of components for compressed air treatment, available in aluminium, technopolymer and steel, in several sizes with connections from 1/8" to 1" and flow rates up to 8000 NI/m

Series AIRPLUS	2.1	Series 1700	2.88	Series 1700 Steel line	2.159
----------------	-----	-------------	------	------------------------	-------



### Proportional technology

The proportional pressure regulators are available in 3 sizes, standard, CANopen® and IO-Link, or miniaturized versions

1700 standard	2.172	1700 miniaturized	2.188
---------------	-------	-------------------	-------



### Measuring devices

Digital pressure switches and pressure gauges, panel mounting or manifold versions

Pressure switches Series DS	2.204	Pressure gauges Series DS	2.206
-----------------------------	-------	---------------------------	-------

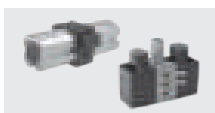

### Pressure booster

3 sizes aluminium pressure boosters available or technopolymer with 2:1 compression ratio

Series 1700	2.208	Series P+	2.213
-------------	-------	-----------	-------

## Section 03 Pneumatic actuation

### Cylinders with piston rod according to standard



### ISO 6432 Microbore cylinders

Versions available: with threaded end caps, rolled end caps, aluminium, stainless steel and technopolymer versions

Series 1200 Threaded end caps cylinders	3.1	Series 1200 Rolled end caps (MIR-INOX)	3.8	Series 1200 Steel line	3.12
Series 1200 Rolled end caps (MIR)	3.4	Series 1200 TECNO-MIR	3.10		



### CNOMO-CETOP-ISO cylinders

Cylinders manufactured according to standards CNOMO, CETOP and ISO: standard versions, through rod versions, tandem push with common rod, tandem push with independent rods or opposed tandem with common rod

Series 1303-1304-1305-1306-1307	3.30
---------------------------------	------



### ISO 15552 cylinders

Cylinders according to ISO 15552 with bores from Ø32 to Ø200 mm and strokes up to 1250 mm. Available versions: ECOPLUS with aluminium or technopolymer end plates, ECOLIGHT optimized in weight and dimensions, Steel line completely in stainless steel, round tube versions tie rod (Ø250-Ø320 mm)

Series 1319-1320-1321	3.40	Series Ecoplus	3.46	Series 1315 Round tube	3.68
Series 1348-1349-1350	3.43	Series Ecolight	3.50	Series Inox Steel line	3.71

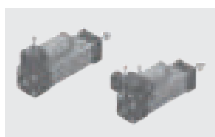

### ISO 15552 Hydro-pneumatic speed control cylinders

ISO 15552 Hydro-pneumatic speed control cylinders with internal hydraulic circuit for movement control

Series 1450-1463	3.81
------------------	------



### ISO 21287 Compact cylinders

Compact cylinders according to standard ISO with integrated slots suitable for sensors mounting without adaptors. Bores from Ø20 to Ø100 mm. Versions with end stroke adjustable pneumatic cushioning are also available according to ISO 21287

Series Ecompact **3.87**

## Cylinders with Piston rod not according to standard



### Threaded body microbore cylinders

Special performance microbore cylinders with hexagonal or round body and either completely threaded or threaded with a plain rod ending

Series 1200 **3.103**

Special performance (1213-1273)



### Non rotating cylinders

Non rotating cylinders twin rod version, available with bores from Ø32 to Ø100 and strokes up to 500 mm

Series **3.105**

1325-1326-1345-1347



### Flat cylinders

ECOFLAT cylinders available with sizes from 25 to 63 mm and strokes up to 300 mm. Profiled tube has two "T" slots to host sensors 1580.\_, MRS.\_, MHS.\_. without adaptors. Two additional connections are also available on rear cover for cylinder feeding

Series ECOFLAT **3.108**

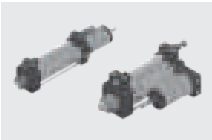

### Hydraulic speed control cylinders

Hydraulic speed control cylinders outward/inward control, and lateral or in-line tank. Available with SKIP valve (accelerating device) and blocking valve (STOP)

Series 1400 **3.115**

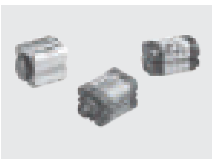

### Short stroke & compact cylinders

Short stroke & compact cylinders with bores from Ø20 to Ø100 mm, available in single and double acting versions, tandem and through rod with magnetic piston versions. The Europe version is compliant with the ISO or UNITOP standard (depending on bores), while the Europe-S versions have connections and rods according to the ISO 15552 standard

Series 1500 **3.127** Europe **3.136** Ecompact-S **3.144**



### Multimount cylinders

Multimount cylinders available with bores from Ø10 to Ø25 mm, with strokes up to 50 mm and with magnetic piston versions

Series 6500 **3.149**



### Guided compact cylinders

These cylinders are available in sizes Ø32 to Ø63 mm, and comprise a single compact cylinder with integral guide rods. The rod guide is available in two styles: self-lubricating bronze bushes and bearing bushes

Series 6100-6101-6110 **3.152**



### Slide cylinders

Slide cylinders manufactured with bores from Ø8 to Ø25 mm, with strokes up to 150 mm. Available with simple and double regulation end stroke and also with front and rear shock absorber

Series 6600 **3.168**

## Section 03

### Pneumatic actuation / Cylinders with piston rod not according to standard (following)



#### Slide units

Twin-rod linear guide units with bores from Ø10 to Ø32 mm, and with control unit with bronze bush versions, with control unit with bearing bush versions. Are also available the through twin-rod slide units and the compact slide units

Series 6200	3.178	Series 6210	3.184	Series 6700	3.189
-------------	-------	-------------	-------	-------------	-------

## Rodless cylinders



#### Mechanically coupled

Mechanically coupled cylinders with bore from Ø16 to Ø63 mm, and strokes up to 6000 mm, available also with linear control unit

Series 1605	3.196	Series 1600 Ø16 mm	3.207
-------------	-------	--------------------	-------



#### Cable driven

Cable driven cylinders with cable linear translation system

Series 1601	3.212
-------------	-------

## Rotary actuators



#### Rack & pinion rotary actuators

Double or single rack & pinion rotary actuators

Series 1330	3.213	Series 6400	3.217	Series 6411	3.221
-------------	-------	-------------	-------	-------------	-------

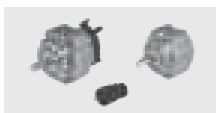

#### Vane type rotary actuators

Vane type rotary actuators with the shaft that runs into ball bearings, available with sizes from Ø10 to Ø100 mm

Series 6420	3.225
-------------	-------

## Handling



#### Pneumatic grippers

Pneumatic grippers with 2 fingers angular opening (-10° to +30°), wide opening 180° or 3 parallel fingers

Series 6301	3.236	Series 6303	3.242	Series 6311	3.248
Series 6302	3.239	Series 6310	3.245	Series 6312	3.251

## Magnetic sensors



#### Standard series

Magnetic sensors with Reed type or Hall effect

Series SA	3.254
-----------	-------





### Miniaturized series

Miniaturized series with Reed and Hall style versions, available with rectangular, square, square section CURS approved, and round section versions

Series SR	3.263	Series SQ	3.265	Series ST	3.266
Series SU CURS	3.264				

## Accessories and fixing devices

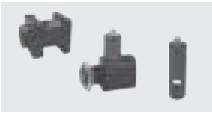

### Piston rod lock

Piston rod lock for cylinders with bores from da Ø12 to Ø125 mm

Series 1260 - 1320	3.269
--------------------	-------



### Linear guides

Linear control units Series 1200 (Ø20-25 mm) and Series 1320 (da Ø32 a Ø80 mm)

Series 1260 - 1320	3.271
--------------------	-------



### Shock absorbers

Shock absorbers with M8x1 - M10x1 - M14x1,5 - M20x1,5 - M27x1,5 threads

Series 6900	3.273
-------------	-------

## Appendix



Pneumatic symbols	A.1
Dimensioning	A.4
Unit of measure, conversion tables	A.13
Alphanumeric index	A.17



# Technologies and competence since 1976

The excellence of Made in Italy in the world for over 40 years



Founded in 1976, **PNEUMAX S.p.A.** is now one of the major international producers of components and systems for automation, leader of the Group of the same name made up of 25 sales and production companies that employ 730 collaborators throughout the world. Continuous investments in research and development have allowed **Pneumax** to broaden its offer of standard products and customised solutions implementing not only the consolidated pneumatic technology but also electrical actuation and fluid control components.

The aim to offer increasingly specialised services and applicative competences has led to the creation of 3 dedicated Business Units, respectively industrial automation, process automation and automotive.



**AUTOMOTIVE**



**INDUSTRIAL  
AUTOMATION**



**PROCESS  
AUTOMATION**

# Think Global Act Local

The certainty of a partner  
always by your side

Pneumax target has always been to provide a complete service both in the pre-sales and after-sales service phases all over the world. The Pneumax network reflects corporate values and vision and at the same time enhance the peculiarities of the different markets and sectors in which it operates. Constant investments aimed at strengthening structures, technologies and skills make Pneumax a real technological partner. Human competence and smart technology represent the essential combination for the creation of quality products.



## An international network

Through a network comprised of branches and exclusive distributors, Pneumax operates in over 50 countries around the world, to support its customers throughout every stage of the supply process, from applicative pre-sales analysis to after-sales assistance.

- ▶ Headquarters
- Branches
- Distributors





## Pneumax Business Attitude

An operational model that stems from the capacity to combine sectorial, technological and applicative competences through the collaboration of customers with our industry Business Specialists and with Product Specialists focused on products and technologies, the most effective solutions are created considering the **TCO** (Total Cost of Ownership) relative to the product's entire life cycle.

### BUSINESS SPECIALISTS

Dedicated competences

- Sectors and Applications

### PRODUCT SPECIALISTS

Specific knowledge

- Products and Technologies



### SALES ENGINEERS

Worldwide Presence

- Relationship management

PNEUMAX  
Headquarters

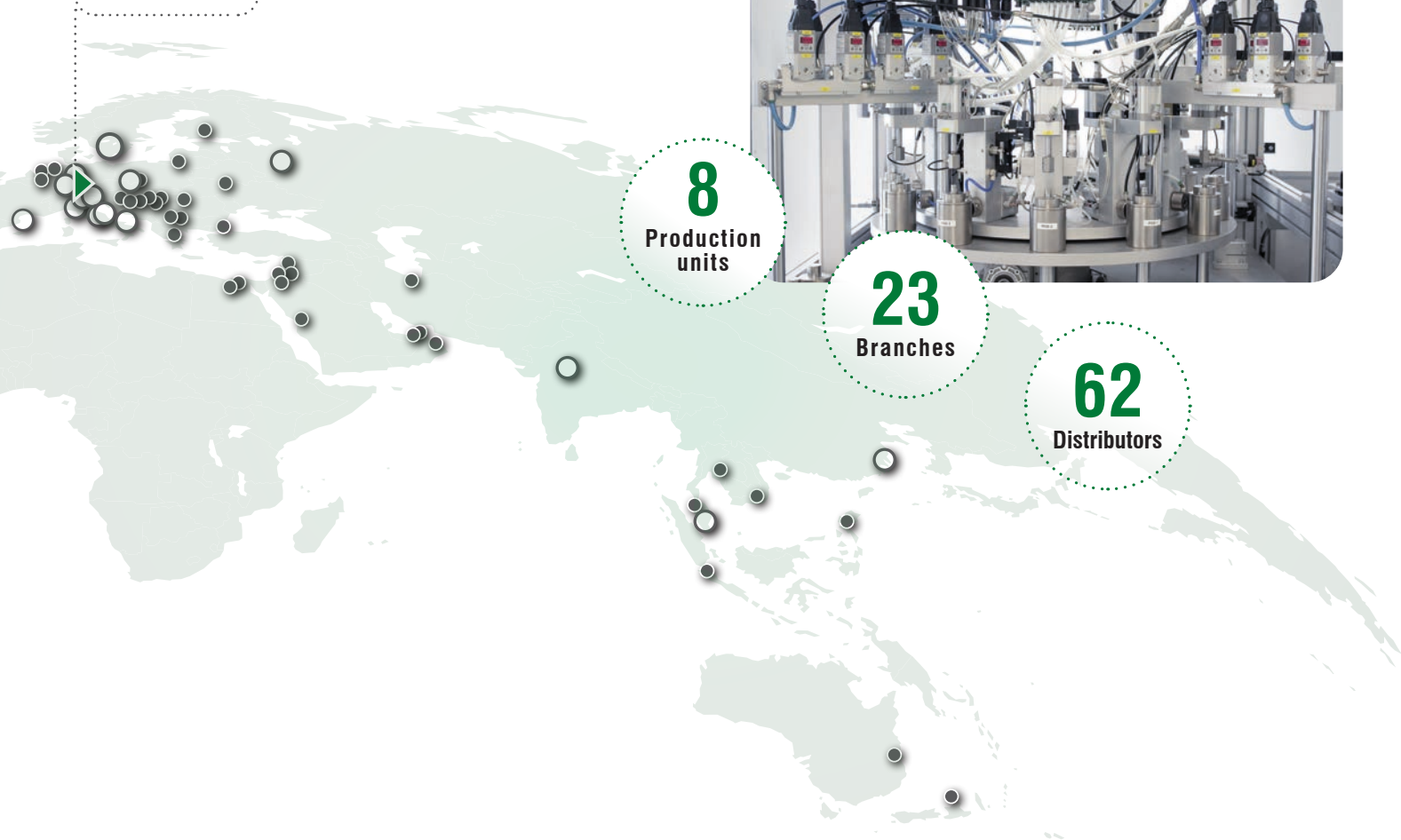

# Products and Technologies

## The value of the solution

Pneumax's technological offer includes various technologies, from pneumatic actuation to electrical actuation, to components for the control of liquid and gaseous fluids, to offer the best solution in every applicative context.



**Pneumatic  
technology**

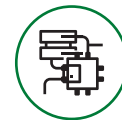

**Electric  
actuation**



**Fluid  
control**

## Special Solutions Services and Products

The supply of custom solutions has always been Pneumax's flagship service. Experience, competence, organisation and use of the most advanced production technologies are at the base of the capacity to offer customised products and services designed and created to fulfill the needs of every single customer.

- **Mechatronic Solutions**
- **Integrated cabinets and systems**
- **Special Processing**
- **Custom Treatments**
- **Special Materials**
- **Customised testing procedures**





## Industrial automation

The Business Unit that produces components and systems for industrial automation represents the core of Pneumax Spa. Founded to create pneumatic components, the company has constantly invested to broaden the offer of products and technologies, implementing not only the consolidated pneumatic actuation but also electrical actuation and fluid control components.



## Process automation

The desire to develop the range of products suitable for use in "process" related sectors that require dedicated materials like stainless steel or special performance such as working pressure in Oil & Gas, has led Pneumax to create a Business Unit dedicated entirely to process automation.

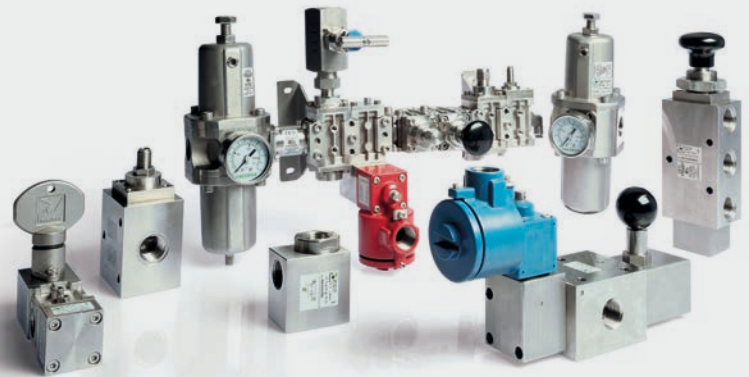

## Automotive

The Pneumax Automotive division offers a complete range of products dedicated to the production lines of the industry, with a special focus on Body in White applications. In fact Pneumax's offer includes clamping units, pin packages, grippers, power pivots and complete multi axes positioning systems.



# Total Quality Management

The highest quality of products and processes guaranteed throughout the supply chain



At Pneumax, Total Quality is an “operating style” constantly nurtured by ongoing training at all levels and an awareness of shared “knowledge” as a corporate asset essential to the company’s success. Choosing to operate under a **Total Quality System** means implementing management methods and tools that involve all staff and enable **constant monitoring of process efficiency and product quality**, starting from the raw materials and the components necessary to make them and continuing through processing and assembly. Pneumax’s manufacturing operations are concentrated at the Lurano production facilities in the province of Bergamo while fittings are manufactured by Titan Engineering, a Pneumax Group Company located in San Marino. To ensure the greatest reliability for our customers, the best suppliers are selected, often right on-site, and mechanical processing is carried out in-house by Supermeccanica another company belonging to the Pneumax Group.







## System and Product Certifications

- SIL certificates of compliance with **IEC 61508** standards
- **UL**  
Product in compliance with US standards
- **EAC**  
Certificate of conformity for the free circulation of products in the Euro-Asian Economic Community
- **ISO 45001:2018**  
Health and safety management system
- **CSA**  
Product in compliance with Canadian standards
- Compliance with Machinery Directive **2006/42/CE**
- **ISO 14001**  
Environmental management systems
- **ISO 9001**  
Quality management system
- Compliance with **ATEX 2014/34/UE** directive
- Well Tried Components **EN ISO 13849**, suitable for application in safety circuits

### Product Certifications:

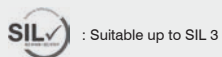
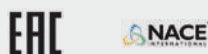
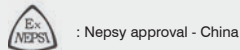
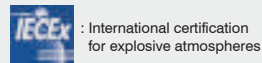
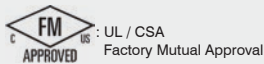

Section 01











# Air distribution

Valves, solenoid valves and devices for compressed air distribution and control

## Valves and solenoid valves

### Spool valves and solenoid valves

Single and manifold versions, mechanical and manual or pneumatic command

	<b>Series 104</b>	1.1		<b>Series 400</b>	1.90
	<b>Series 105</b>	1.12		<b>Series T400</b>	1.109
	<b>Series 200</b>	1.21		<b>Series 2100</b> Line-Flat-Base	1.123
	<b>Series T200</b>	1.54		<b>Series 2400</b> Line-Flat-VDMA	1.139
	<b>Series 800</b>	1.68		<b>Series 2600</b> Line-Flat-VDMA	1.162
	<b>Series 888</b>	1.77			

### Direct operated solenoid valves

Pilot valves, high flow rate performance 2/2 ways and 3/2 ways, miniaturized version available as well

	<b>Series 300</b>	1.178		<b>Series S</b>	1.204
	<b>Solenoid coils</b>	1.193		<b>300-UL solenoid coils</b>	1.206
	<b>Series M (Mechanical)</b>	1.196		<b>UL solenoid coils</b>	1.206
	<b>Series CNOMO</b>	1.201			



## Poppet valves and solenoid valves

3/2 & 2/2 valves and solenoid valves for compressed air and vacuum, with aluminium and technopolymer body. 2/2 pad valves, shutter seating, angle seated solenoid valves for fluids

	<b>Series 700</b>	1.208
	<b>Series N776</b>	1.221
	<b>Series T772-773</b>	1.226
	<b>Series T771</b>	1.241

	<b>Series PVA</b>	1.249
	<b>Series F300</b>	1.253
	<b>Series PVF</b>	1.282

## “Namur” valves and solenoid valves

Namur valves and solenoid valves according to standard ISO 5599/1 available in 3 sizes with M12 5/2, 5/3 connectors, aluminium and technopolymer body

	<b>Series 514/N</b>	1.283
	<b>Series T514</b>	1.285

	<b>Series 514</b>	1.290
	<b>Series 515</b>	1.297

## ISO 5599/1 valves and solenoid valves

Valves and solenoid valves according to standard ISO 5599/1 available in 3 sizes with M12 5/2, 5/3 connectors, aluminium and technopolymer body

	<b>Series 1000</b>	1.303
---	--------------------	-------

	<b>Series 1000-M12</b>	1.320
---	------------------------	-------

## Accessories

### Pneumatic circuit accessories

Flow control valves, quick exhaust valves, selectors, silencers, unidirectional valves, manifolds, blocking valves, economizers, gang mounting manifolds, spray valves

	<b>Series 600</b>	1.327
---	-------------------	-------

### Complementary valves

Pressure switches, impulse generators, timers, two hands safety valve, oscillator valve, signal amplifier, progressive start up valve, high-low pressure device

	<b>Series 900</b>	1.341
---	-------------------	-------

### Blocking valves

Unidirectional and bidirectional blocking valves, aluminium and technopolymer versions, with G1/8" - G1/4" - G3/8" - G1/2" connections

	<b>Series 50-T50</b>	1.349
---	----------------------	-------

### Function fittings

Miniaturized logic function with technopolymer body: RFU, RP, VB, VSR, VS-or, VS-and, IP, AP, RP+IP, VB+RFU, VB+VSR

	<b>Series 55-TecnoFUN</b>	1.354
---	---------------------------	-------

## Accessories (following)

### Miniaturised pressure regulators

Brass versions rod G1/8" with technopolymer body and integrated gauge version

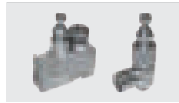

**Series 1750 - 1760**

1.369

### Compact fittings for lubrication

Nichel plated brass compact fittings, with straight male adaptor



**Series Mini-RAP**

1.371

## Valves and solenoid valve manifolds

Wide range of multipole & serial systems, available with main fieldbus protocols



**Series 2700 - ISO15407-2**

1.373



**Series 2500 Optyma-F**

1.455



**Series 2300 Enova**

1.400



**Series 2500 Optyma-T**

1.486



**Series 2200 Optyma-S**

1.421



**Series 3000**

1.520



**Series 2200 Optyma-Sc**

1.448

## Series 104

### General

The micro valves 104 series are a cost effective solution with reduced overall dimensions, easy to install and manage. Their main characteristic is the possibility to choose between the version with lateral or rear pneumatic connections realized with quick fitting for Ø4mm tube included.

The valves are available with 2 or 3 ways versions, normally closed or open, 5 ways and 5 ways 3 positions open centres and pressured centres.

The 5 ways version is made with two 3 ways valves placed side by side with common inlet.

The operators available for this valve are push button (different versions), selector (key, short and long lever), lever (lever roller or level unidirectional) and pneumatic.

It is also possible to combine the 2 and 3 ways valves with electrical switches, normally closed or open.

### Construction characteristics

Body and cover	Technopolymer
Operators	Plastic material for buttons and switches
Seals	NBR
Spacer	Technopolymer
Spools	Steel
Springs	Spring steel
Pistons	Aluminium (for pneumatic command version)

### Use and maintenance

This valves have an average life of 15 million cycles depending on the application and air quality.

Filtered and lubricated air using specified lubricants will reduce the wear of the seals and ensures long and trouble free operation.

Please ensure that the valve is being used according with the manufacturers specification, such as air pressure and temperature.

**ATTENTION:** use hydraulic oil class H for lubrication such as MAGNA GC 32 (Castrol).

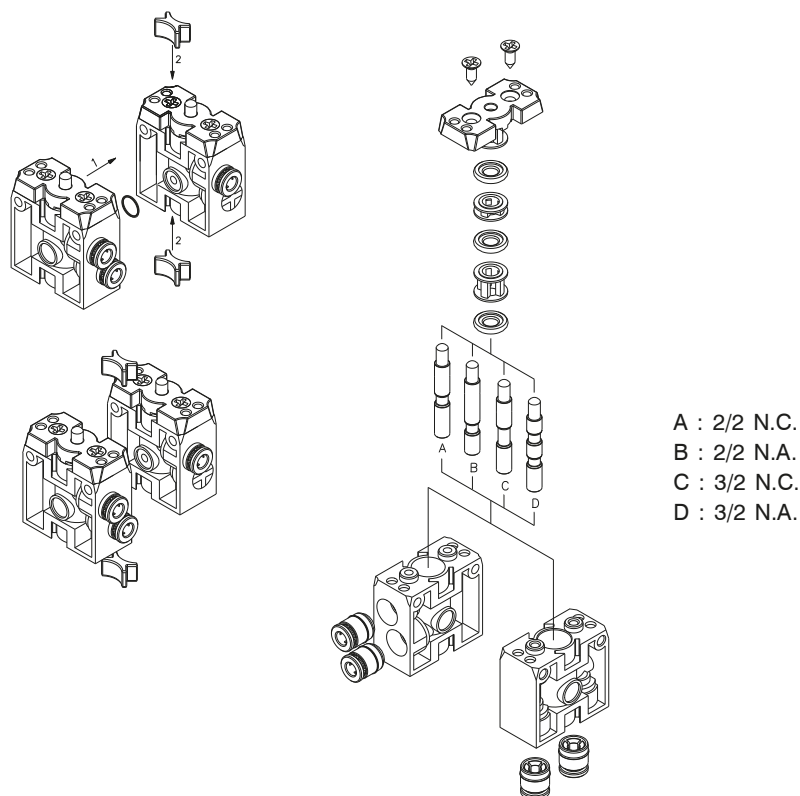



1  
AIR DISTRIBUTION

**Tappet - Spring**

Coding: 104.●.0.1.●.●.●

**Operational characteristics**

Fluid	Filtered air. No lubrication needed, if applied it shall be continuous
Max working pressure (bar)	10
Temperature °C	-5 ÷ +70
Flow rate at 6 bar with Δp=1 (NI/min)	90
Orifice size (mm)	2.5
Working ports size	ø4 tube

●	TYPE	FUNCTION
	22 = 2 ways 32 = 3 ways	A = Normally Open C = Normally Closed
●	CONNECTION TYPE	
	L = Lateral	
	P = Rear	

2/2 - 3/2 - Lateral connections

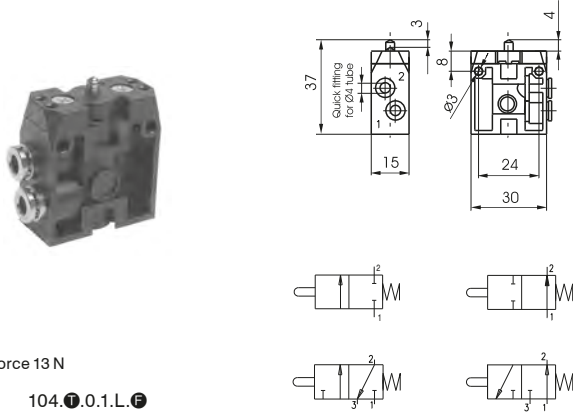

Weight 20 g  
Operating force 13 N

104.●.0.1.L.●

2/2 - 3/2 - Rear connections

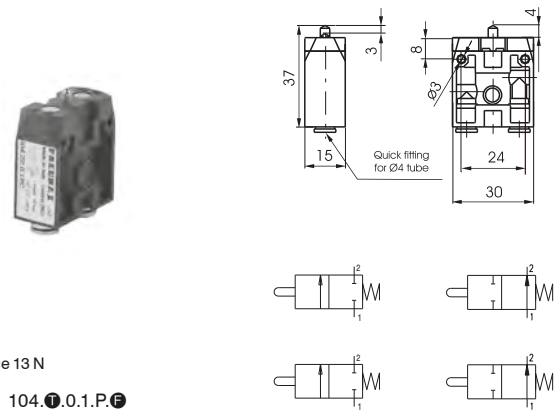

Weight 20 g  
Operating force 13 N

104.●.0.1.P.●

**Push button - Spring**

Coding: 104.●.6.22/●.●.●.●

**Operational characteristics**

Fluid	Filtered air. No lubrication needed, if applied it shall be continuous
Max working pressure (bar)	10
Temperature °C	-5 ÷ +70
Flow rate at 6 bar with Δp=1 (NI/min)	90
Orifice size (mm)	2.5
Working ports size	ø4 tube

●	TYPE	CONNECTION TYPE
	22 = 2 ways 32 = 3 ways 52 = 5 ways	L = Lateral P = Rear
	BUTTON COLOR	FUNCTION (only for 2 or 3 ways)
●	1 = Red 2 = Black 3 = Green 4 = Yellow	A = Normally Open C = Normally Closed

2/2 - 3/2 - Lateral connections

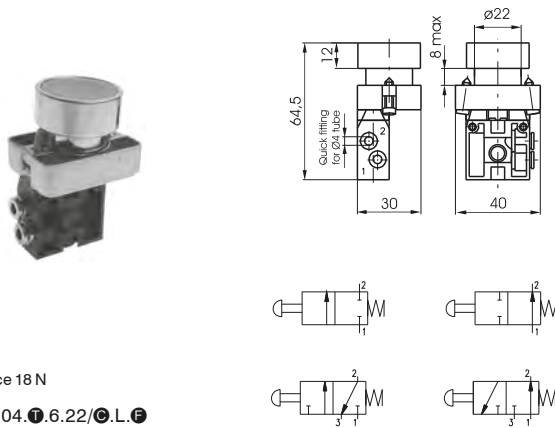

Weight 50 g  
Operating force 18 N

104.●.6.22/●.L.●

2/2 - 3/2 - Rear connections

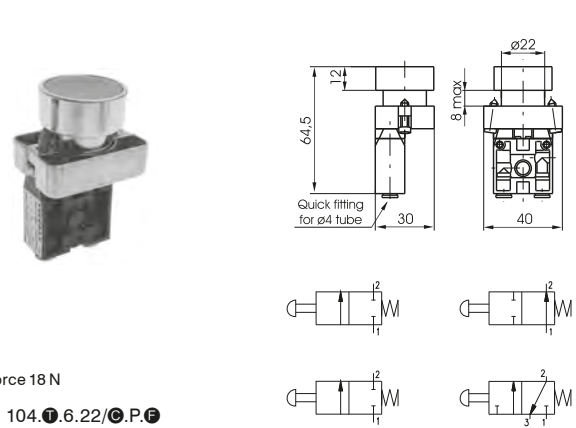

Weight 50 g  
Operating force 18 N

104.●.6.22/●.P.●

5/2 - Lateral connections

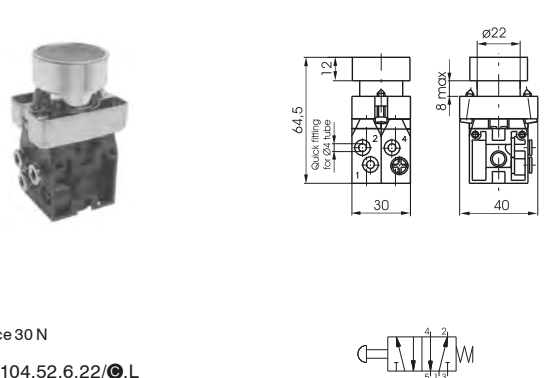

Weight 105 g  
Operating force 30 N

104.52.6.22/●.L

5/2 - Rear connections

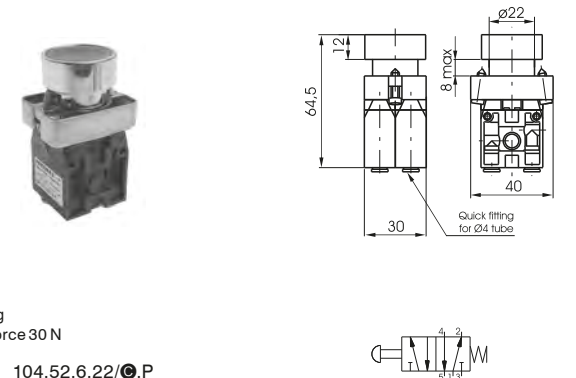

Weight 105 g  
Operating force 30 N

104.52.6.22/●.P

**Push button 2 positions (step - step)**

Coding: 104. **T**.6.31. **W**. **F**

Operational characteristics	
Fluid	Filtered air. No lubrication needed, if applied it shall be continuous
Max working pressure (bar)	10
Temperature °C	-5 ÷ +70
Flow rate at 6 bar with Δp=1 (Nl/min)	90
Orifice size (mm)	2.5
Working ports size	ø4 tube

<b>T</b>	TYPE
	22 = 2 ways
	32 = 3 ways
<b>W</b>	CONNECTION TYPE
	L = Lateral
	P = Rear

<b>F</b>	FUNCTION (only for 2/2 and 3/2 ways)
	A = Normally Open
	C = Normally Closed

**2/2 - 3/2 - Lateral connections**

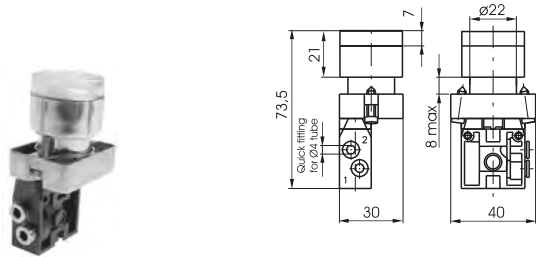

Weight 60 g  
Operating force 18 N

104. **T**.6.31. **L**. **F**

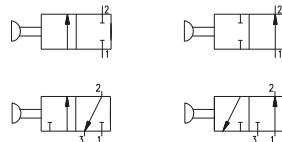

**2/2 - 3/2 - Rear connections**

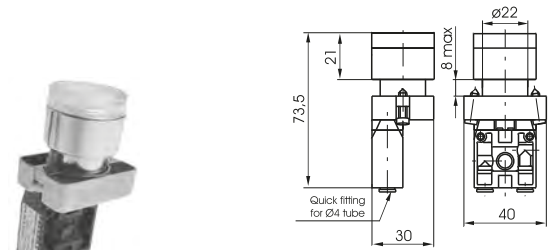

Weight 60 g  
Operating force 18 N

104. **T**.6.31. **P**. **F**

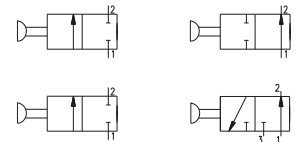

**5/2 - Lateral connections**

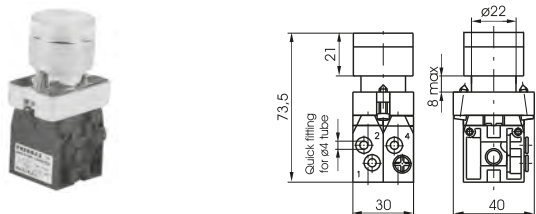

Weight 110 g  
Operating force 30 N

104.52.6.31.L

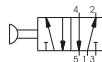

**5/2 - Rear connections**

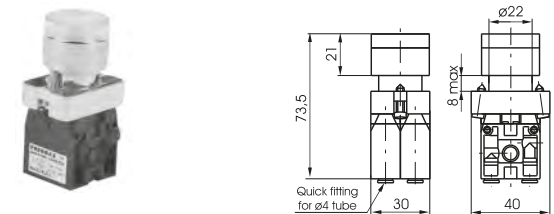

Weight 110 g  
Operating force 30 N

104.52.6.31.P

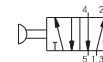



**Raised Push button - Spring**

Coding: 104. **T**.6.23/**C.W.F**

**Operational characteristics**

Fluid	Filtered air. No lubrication needed, if applied it shall be continuous
Max working pressure (bar)	10
Temperature °C	-5 ÷ +70
Flow rate at 6 bar with $\Delta p=1$ (NI/min)	90
Orifice size (mm)	2.5
Working ports size	$\varnothing 4$ tube

<b>T</b>	TYPE	<b>W</b>	CONNECTION TYPE	
	22 = 2 ways		L = Lateral	
	32 = 3 ways		P = Rear	
<b>C</b>	52 = 5 ways	<b>F</b>	FUNCTION (only for 2 or 3 ways)	
	BUTTON COLOR		A = Normally Open	
	1 = Red		C = Normally Closed	
	2 = Black			
	3 = Green			
	4 = Yellow			

1  
AIR DISTRIBUTION

**2/2 - 3/2 - Lateral connections**

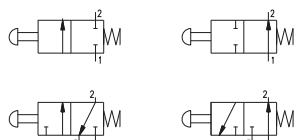
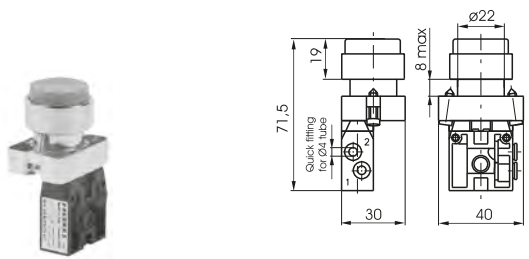

Weight 50 g  
Operating force 18 N

104. **T**.6.23/**C.L.F**

**2/2 - 3/2 - Rear connections**

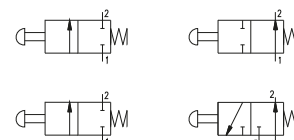
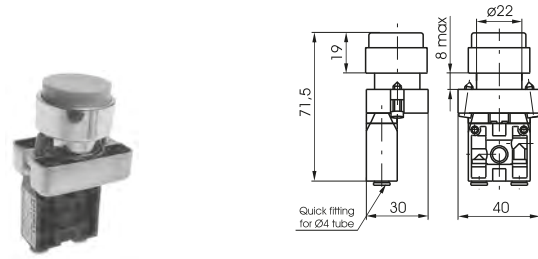

Weight 50 g  
Operating force 18 N

104. **T**.6.23/**C.P.F**

**5/2 - Lateral connections**

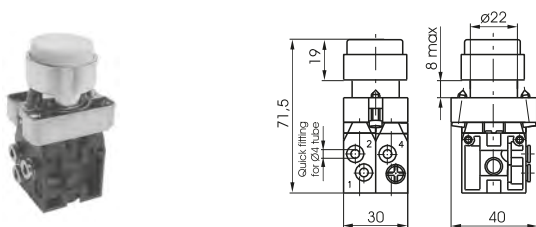

Weight 105 g  
Operating force 30 N

104.52.6.23/**C.L**

**5/2 - Rear connections**

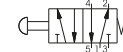
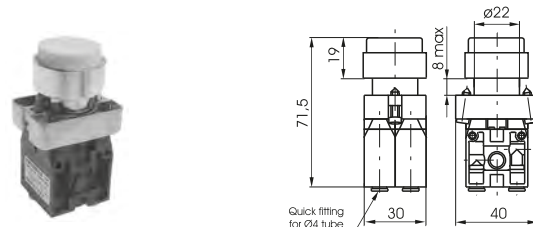

Weight 105 g  
Operating force 30 N

104.52.6.23/**C.P**



**Palm button 2 position**

Coding: 104. **T**.6.25. **W**. **F**

Operational characteristics	
Fluid	Filtered air. No lubrication needed, if applied it shall be continuous
Max working pressure (bar)	10
Temperature °C	-5 ÷ +70
Flow rate at 6 bar with Δp=1 (Nl/min)	90
Orifice size (mm)	2.5
Working ports size	ø4 tube

<b>T</b>	TYPE
	22 = 2 ways
	32 = 3 ways
	52 = 5 ways
<b>W</b>	CONNECTION TYPE
	L = Lateral
	P = Rear

<b>F</b>	FUNCTION (only for 2/2 and 3/2 ways)
	A = Normally Open
	C = Normally Closed

2/2 - 3/2 - Lateral connections

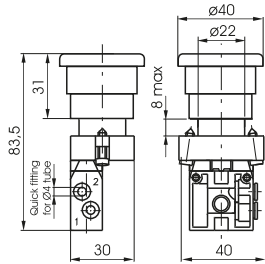

Weight 65 g  
Operating force 19 N  
Emergency - Rotate to unlock

104. **T**.6.25. **L**. **F**

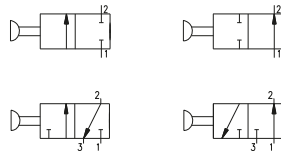

2/2 - 3/2 - Rear connections

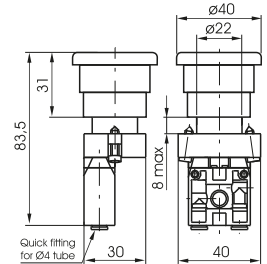

Weight 65 g  
Operating force 19 N  
Emergency - Rotate to unlock

104. **T**.6.25. **P**. **F**

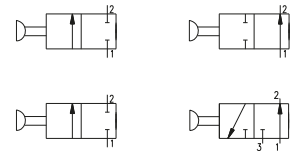

5/2 - Lateral connections

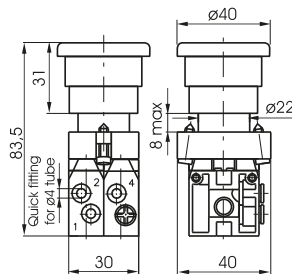

Weight 120 g  
Operating force 32 N  
Emergency - Rotate to unlock

104.52.6.25.L

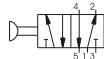

5/2 - Rear connections

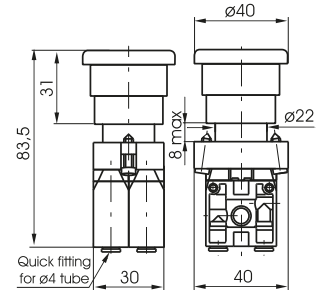

Weight 120 g  
Operating force 32 N  
Emergency - Rotate to unlock

104.52.6.25.P

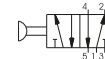

1  
AIR DISTRIBUTION

**Switch - short lever**

Coding: 104. **T**. **F**. 1.6.30. **S**. **W**. **F**2

**Operational characteristics**

Fluid	Filtered air. No lubrication needed, if applied it shall be continuous
Max working pressure (bar)	10
Temperature °C	-5 ÷ +70
Flow rate at 6 bar with Δp=1 (NI/min)	90
Orifice size (mm)	2.5
Working ports size	ø4 tube

<b>T</b>	TYPE	<b>S</b>	SWITCH POSITION (only for 2/2 and 3/2 ways)
	22 = 2 ways		0 = 3 pos. instable
	32 = 3 ways		1 = 3 pos. stable
	52 = 5 ways		
<b>F</b> 1	FUNCTION (only for 5/3 ways)	<b>W</b>	CONNECTION TYPE
	32 = Open centres		L = Lateral
	33 = Pressured centres		P = Rear
		<b>F</b> 2	FUNCTION (only for 2/2 or 3/2 ways)
			A = Normally Open
			C = Normally Closed

AIR DISTRIBUTION

**2/2 - 3/2 - Lateral connections**

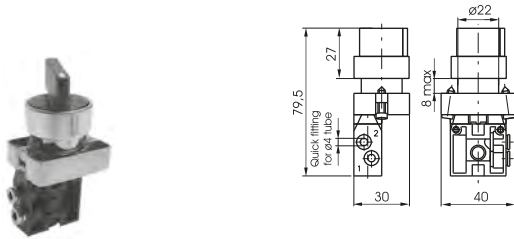

Weight 65 g  
Switch 2 positions stable

104. **T**. **F**. 6.30. **L**. **F**

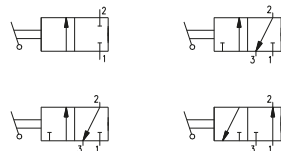

**2/2 - 3/2 - Rear connections**

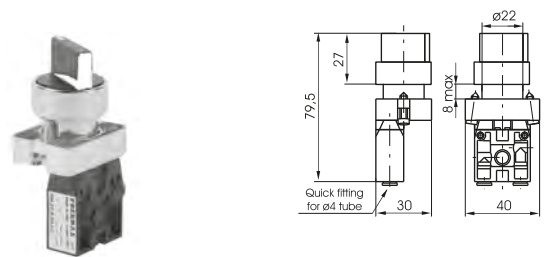

Weight 65 g  
Switch 2 positions stable

104. **T**. 6.30. **P**. **F**

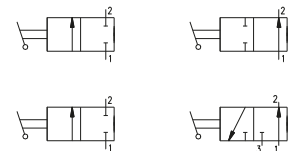

**5/2 - Lateral connections**

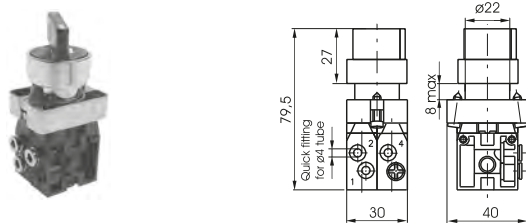

Weight 120 g  
Switch 2 positions stable

104.52.6.30.L

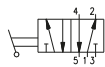

**5/2 - Rear connections**

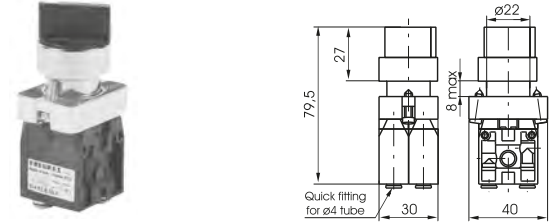

Weight 120 g  
Switch 2 positions stable

104.52.6.30.P

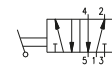

**5/3 - Lateral connections**

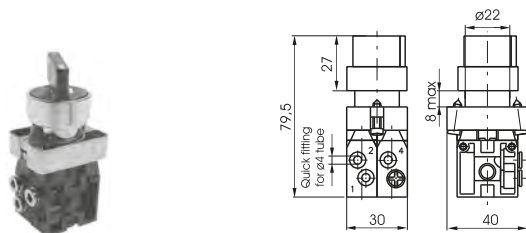

Weight 120 g

104.53. **F**. 6.30. **S**. **L**

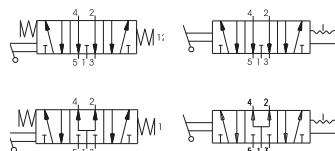

**5/3 - Rear connections**

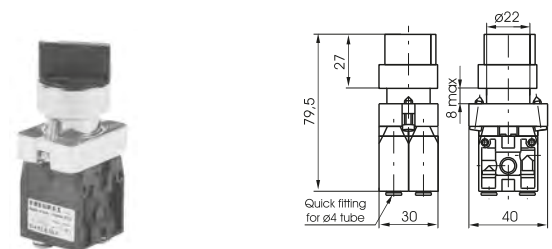

Weight 120 g

104.53. **F**. 6.30. **S**. **P**

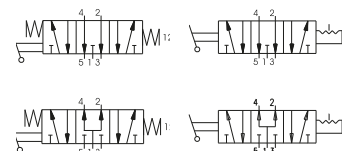

Switch - long lever

Coding: 104. **T**. **F**1.6.27. **S**. **W**. **F**2

Operational characteristics	
Fluid	Filtered air. No lubrication needed, if applied it shall be continuous
Max working pressure (bar)	10
Temperature °C	-5 ÷ +70
Flow rate at 6 bar with Δp=1 (Nl/min)	90
Orifice size (mm)	2.5
Working ports size	ø4 tube

<b>T</b>	TYPE	<b>S</b>	SWITCH POSITION (only for 2/2 and 3/2 ways)
	22 = 2 ways		0 = 3 pos. instable
	32 = 3 ways		1 = 3 pos. stable
	52 = 5 ways		CONNECTION TYPE
53 = 5 ways	<b>W</b>		L = Lateral
<b>F</b> 1	FUNCTION (only for 5/3 ways)	P = Rear	FUNCTION (only for 2/2 or 3/2 ways)
	32 = Open centres	<b>F</b> 2	A = Normally Open
	33 = Pressured centres		C = Normally Closed

2/2 - 3/2 - Lateral connections

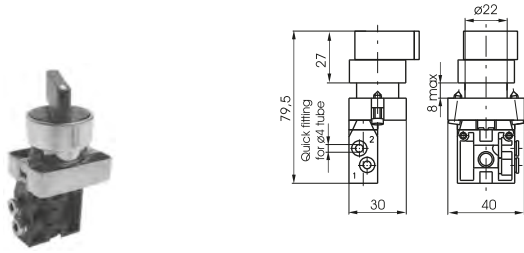

Weight 65 g  
Switch 2 positions stable  
104. **T**.6.27.L. **F**

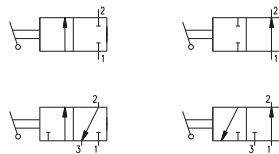

2/2 - 3/2 - Rear connections

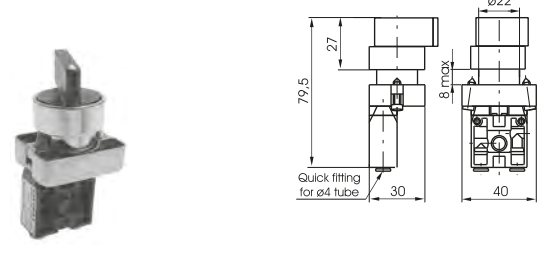

Weight 65 g  
Switch 2 positions stable  
104. **T**.6.27.P. **F**

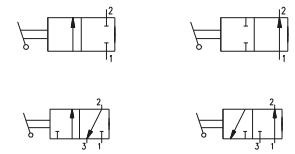

5/2 - Lateral connections

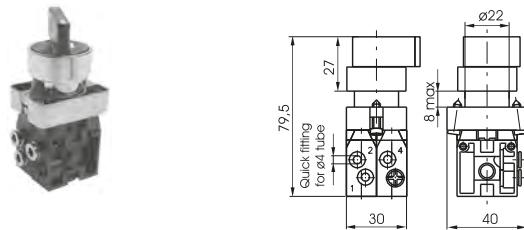

Weight 120 g  
Switch 2 positions stable  
104.52.6.27.L

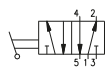

5/2 - Rear connections

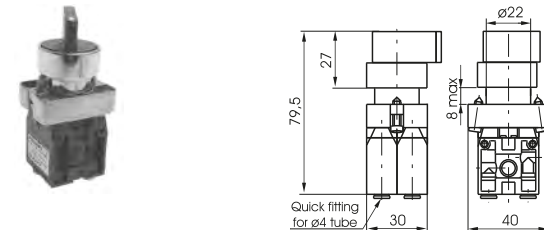

Weight 120 g  
Switch 2 positions stable  
104.52.6.27.P

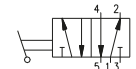

5/3 - Lateral connections

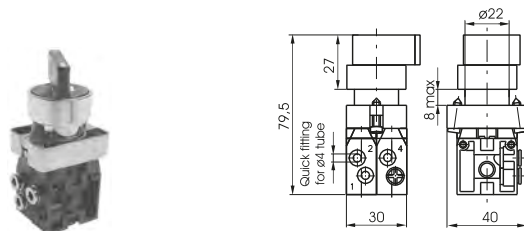

Weight 120 g  
104.53. **F**1.6.27. **S**.L

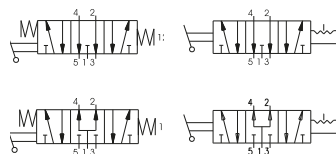

5/3 - Rear connections

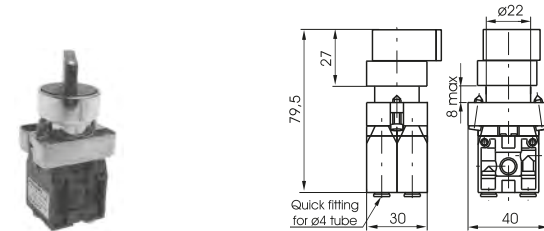

Weight 120 g  
104.53. **F**2.6.27. **S**.P

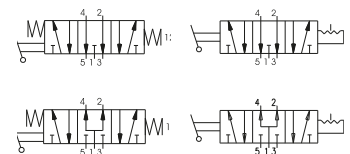

**Key switch**

Coding: 104. **T**. **F**1.6.28. **S**. **W**. **F**2

**Operational characteristics**

Fluid	Filtered air. No lubrication needed, if applied it shall be continuous
Max working pressure (bar)	10
Temperature °C	-5 ÷ +70
Flow rate at 6 bar with Δp=1 (NI/min)	90
Orifice size (mm)	2.5
Working ports size	ø4 tube

<b>T</b>	TYPE	SWITCH POSITION (only for 2/2 and 3/2 ways)
	22 = 2 ways	<b>S</b> 0 = 3 pos. instable
	32 = 3 ways	1 = 3 pos. stable
	52 = 5 ways	
<b>F1</b>	FUNCTION 1 (only for 5/3 ways)	CONNECTION TYPE
	32 = Open centres	<b>W</b> L = Lateral
	33 = Pressured centres	P = Rear
<b>F2</b>	FUNCTION 2 (only for 2/2 or 3/2 ways)	
		<b>F2</b> A = Normally Open C = Normally Closed

AIR DISTRIBUTION

**2/2 - 3/2 - Lateral connections**

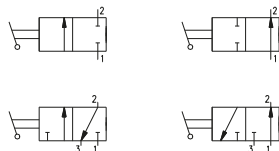
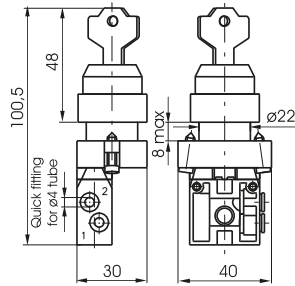

Weight 100 g  
Switch 2 positions stable

104. **T**.6.28.L. **F**

**2/2 - 3/2 - Rear connections**

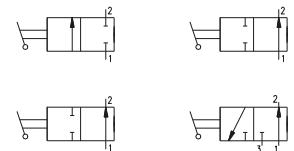
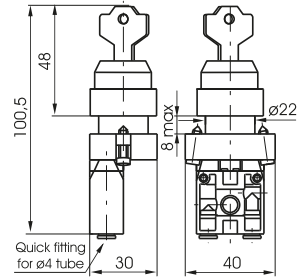

Weight 100 g  
Switch 2 positions stable

104. **T**.6.28.P. **F**

**5/2 - Lateral connections**

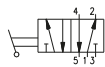
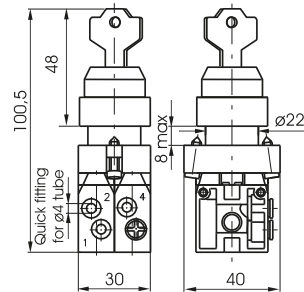

Weight 155 g  
Switch 2 positions stable

104.52.6.28.L

**5/2 - Rear connections**

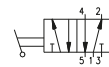
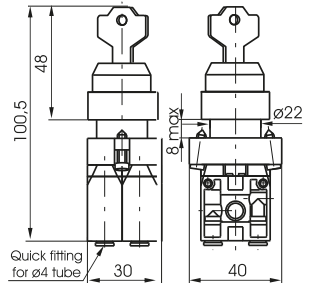

Weight 155 g  
Switch 2 positions stable

104.52.6.28.P

**5/3 - Lateral connections**

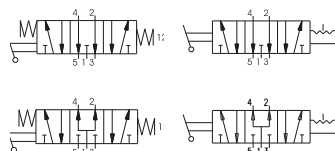
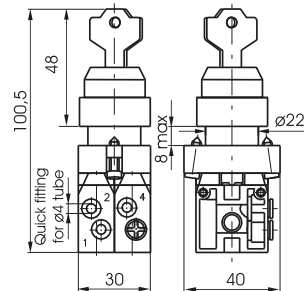

Weight 155 g

104.53. **F**.6.28. **S**.L

**5/3 - Rear connections**

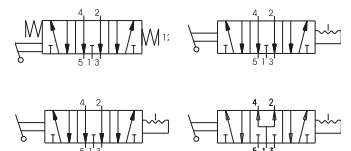
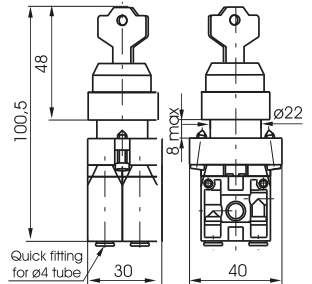

Weight 155 g

104.53. **F**.6.28. **S**.P

**Lever roller - Spring**

Coding: 104. **T**.2.1. **W**. **F**

Operational characteristics	
Fluid	Filtered air. No lubrication needed, if applied it shall be continuous
Max working pressure (bar)	10
Temperature °C	-5 ÷ +70
Flow rate at 6 bar with Δp=1 (NI/min)	90
Orifice size (mm)	2.5
Working ports size	ø4 tube

<b>T</b>	TYPE
	22 = 2 ways 32 = 3 ways
<b>W</b>	CONNECTION TYPE
	L = Lateral
	P = Rear

<b>F</b>	FUNCTION
	A = Normally Open
	C = Normally Closed

2/2 - 3/2 - Lateral connections

Weight 31 g  
Operating force 9 N

104. **T**.2.1.L. **F**

2/2 - 3/2 - Rear connections

Weight 31 g  
Operating force 9 N

104. **T**.2.1.P. **F**

**Lever roller ball bearing - Spring**

Coding: 104. **T**.2.1/1. **W**. **F**

Operational characteristics	
Fluid	Filtered air. No lubrication needed, if applied it shall be continuous
Max working pressure (bar)	10
Temperature °C	-5 ÷ +70
Flow rate at 6 bar with Δp=1 (NI/min)	90
Orifice size (mm)	2.5
Working ports size	ø4 tube

<b>T</b>	TYPE
	22 = 2 ways 32 = 3 ways
<b>W</b>	CONNECTION TYPE
	L = Lateral
	P = Rear

<b>F</b>	FUNCTION
	A = Normally Open
	C = Normally Closed

2/2 - 3/2 - Lateral connections

Weight 46 g  
Operating force 9 N

104. **T**.2.1/1.L. **F**

2/2 - 3/2 - Rear connections

Weight 46 g  
Operating force 9 N

104. **T**.2.1/1.P. **F**

**Lever unidirectional - Spring**

Coding: 104. **T**.3.1. **W**. **F**

Operational characteristics	
Fluid	Filtered air. No lubrication needed, if applied it shall be continuous
Max working pressure (bar)	10
Temperature °C	-5 ÷ +70
Flow rate at 6 bar with Δp=1 (NI/min)	90
Orifice size (mm)	2.5
Working ports size	ø4 tube

<b>T</b>	TYPE
	22 = 2 ways 32 = 3 ways
<b>W</b>	CONNECTION TYPE
	L = Lateral
	P = Rear

<b>F</b>	FUNCTION
	A = Normally Open
	C = Normally Closed

2/2 - 3/2 - Lateral connections

Weight 31 g  
Operating force 9 N

104. **T**.3.1.L. **F**

2/2 - 3/2 - Rear connections

Weight 31 g  
Operating force 9 N

104. **T**.3.1.P. **F**

1  
AIR DISTRIBUTION

▶ Complete lever roller operator

Coding: 104.2.1



▶ Complete lever unidirectional

Coding: 104.3.1



▶ Push button

Coding: 104.6.22/Ⓢ



BUTTON COLOR	
1	= Red
2	= Black
3	= Green
4	= Yellow

▶ Push button 2 positions

Coding: 104.6.31

(step - step)



▶ Switch - short lever

Coding: 104.6.30.Ⓢ



SWITCH POSITION (only for 3 position)	
0	= 3 pos. instable
1	= 3 pos. stable

Switch 2 positions stable 104.6.30

Switch 3 positions 104.6.30.Ⓢ

▶ Key switch

Coding: 104.6.28.Ⓢ



SWITCH POSITION (only for 3 position)	
0	= 3 pos. instable
1	= 3 pos. stable

Switch 2 positions stable 104.6.28

Switch 3 positions 104.6.28.Ⓢ

▶ Contact electric element

Coding: 104.Ⓕ



FUNCTION	
NO	= Normally Open
NC	= Normally Closed

▶ Push button protection cover

Coding: 104.02



▶ Complete lever roller ball bearing operator

Coding: 104.2.1/1



▶ Fixing plate

Coding: 104.00



▶ Raised Push button

Coding: 104.6.23/Ⓢ



BUTTON COLOR	
1	= Red
2	= Black
3	= Green
4	= Yellow

▶ Palm button 2 position

Coding: 104.6.25

Emergency - Rotate to unlock



▶ Switch - long lever

Coding: 104.6.27.Ⓢ



SWITCH POSITION (only for 3 position)	
0	= 3 pos. instable
1	= 3 pos. stable

Switch 2 positions stable 104.6.27

Switch 3 positions 104.6.27.Ⓢ

▶ Joystick selector switch

Coding: 104.6.39.Ⓢ



▶ Complete Pneumatic Operator

Coding: 104.11



**Pneumatic - Spring**

Coding: 104. **T**.11.1. **W**. **F**

Operational characteristics	
Fluid	Filtered air. No lubrication needed, if applied it shall be continuous
Max working pressure (bar)	10
Temperature °C	-5 ÷ +50
Flow rate at 6 bar with Δp=1 (Nl/min)	90
Orifice size (mm)	2.5
Working ports size	ø4 tube
Pilot ports size	M5

<b>T</b>	TYPE
	22 = 2 ways 32 = 3 ways
<b>W</b>	CONNECTION TYPE
	L = Lateral
	P = Rear

<b>F</b>	FUNCTION
	A = Normally Open
	C = Normally Closed

2/2 - 3/2 - Lateral connections

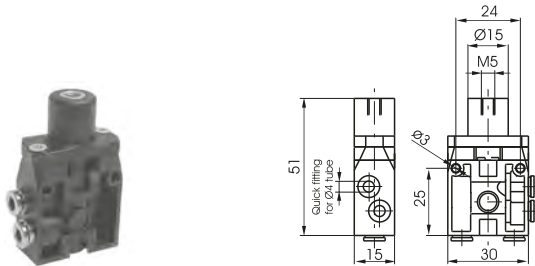

Weight 25 g  
Minimum piloting pressure 2,5 bar

104.22.11.1.L. **F**

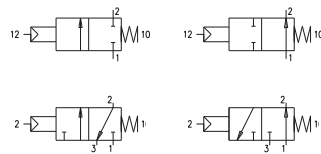

2/2 - 3/2 - Rear connections

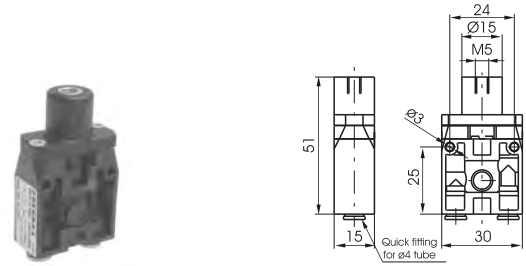

Weight 25 g  
Minimum piloting pressure 2,5 bar

104.32.11.1.P. **F**

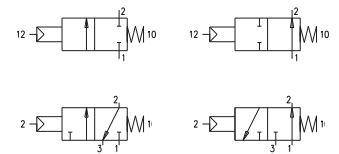

1  
AIR DISTRIBUTION



**Series 105**

**General**

The series 105 consist of a broad range of miniature valves and valves with various type of actuation.  
 The connections are M5 for this series  
 Due to their special construction with a balanced spool, these valves can be used interchangeably as 3 ways or 5 ways.  
 The 3 ways can be used normally closed or normally open and the 5 ways can be fed through the exhausts 3 and 5 with different pressures according to the need.  
 The spool, as it is moving, isolates the connections without being affected by the inlet pressure.

**Construction characteristics**

	<b>M5</b>
Body	Aluminium
Operators	Nickel plated brass Stainless steel for roller levers and button levers; Zinc plated steel for side levers; Plastic material for handles, buttons and switches Aluminium (for pneumatic command version)
Seals	NBR
Spacer	Technopolymer
Spools	Steel
Springs	Spring steel
Pistons	Aluminium (for pneumatic command version)

**Use and maintenance**

This valves have an average life of 15 million cycles depending on the application and air quality.  
 Filtered and lubricated air using specified lubricants will reduce the wear of the seals and ensures long and trouble free operation.  
 Please ensure that the valve is being used according with the manufacturers specification, such as air pressure and temperature.  
 The exhaust port of the distributor has to be protected in a dusty and dirty environment.  
 Repair kits including the spool complete with seals are available for overhauling the valves.  
 However, although this is a simple operation it should be carried out by a competent person.

**ATTENTION:** use hydraulic oil class H for lubrication such as MAGNA GC 32 (Castrol).

1  
AIR DISTRIBUTION



### Tappet panel - Spring

Coding: 105.1.0.1

Operational characteristics	
Fluid	Filtered air. No lubrication needed, if applied it shall be continuous
Max working pressure (bar)	10
Temperature °C	-5 ÷ +70
Flow rate at 6 bar with $\Delta p=1$ (NI/min)	120
Orifice size (mm)	2.5
Working ports size	M5

TYPE	
32	= 3 ways
52	= 5 ways

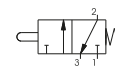

105.32.0.1

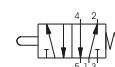

105.52.0.1

3 ways



Weight 70 g  
Operating force 14 N

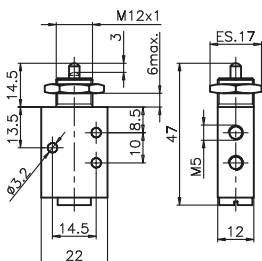

5 ways



Weight 87 g  
Operating force 14 N

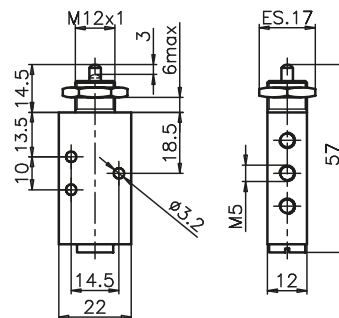

### Lever roller - Spring

Coding: 105.1.2.1

Operational characteristics	
Fluid	Filtered air. No lubrication needed, if applied it shall be continuous
Max working pressure (bar)	10
Temperature °C	-5 ÷ +70
Flow rate at 6 bar with $\Delta p=1$ (NI/min)	120
Orifice size (mm)	2.5
Working ports size	M5

TYPE	
32	= 3 ways
52	= 5 ways

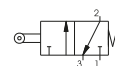

105.32.2.1

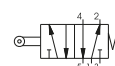

105.52.2.1

3 ways



Weight 85 g  
Operating force 6 N

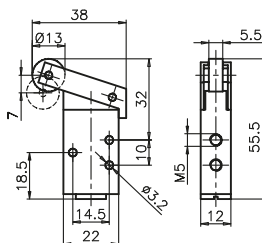

5 ways



Weight 102 g  
Operating force 6 N

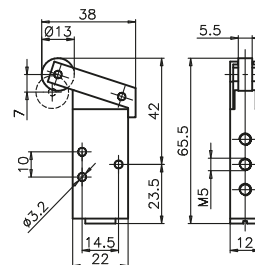

### Lever roller ball bearing - Spring

Coding: 105.1.2.1/1

Operational characteristics	
Fluid	Filtered air. No lubrication needed, if applied it shall be continuous
Max working pressure (bar)	10
Temperature °C	-5 ÷ +70
Flow rate at 6 bar with $\Delta p=1$ (NI/min)	120
Orifice size (mm)	2.5
Working ports size	M5

TYPE	
32	= 3 ways
52	= 5 ways

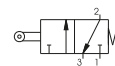

105.32.2.1/1

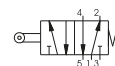

105.52.2.1/1

3 ways



Weight 100 g  
Operating force 6 N

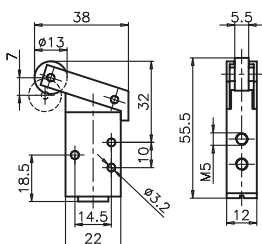

5 ways



Weight 177 g  
Operating force 6 N

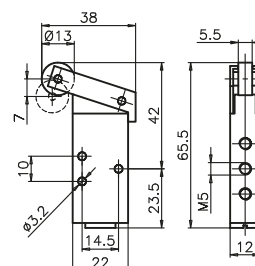

**Lever button - Spring**

Coding: 105.1.2.6/C

**Operational characteristics**

Fluid	Filtered air. No lubrication needed, if applied it shall be continuous
Max working pressure (bar)	10
Temperature °C	-5 ÷ +70
Flow rate at 6 bar with Δp=1 (NI/min)	120
Orifice size (mm)	2.5
Working ports size	M5

TYPE	32 = 3 ways 52 = 5 ways
BUTTON COLOR	1 = Red 2 = Black 3 = Green

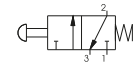

105.32.2.6/C

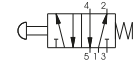

105.52.2.6/C

3 ways

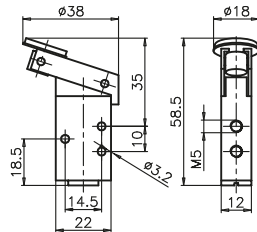

Weight 85 g  
Operating force 6 N

5 ways

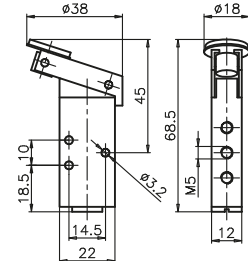

Weight 102 g  
Operating force 6 N

**Lever unidirectional - Spring**

Coding: 105.1.3.1

**Operational characteristics**

Fluid	Filtered air. No lubrication needed, if applied it shall be continuous
Max working pressure (bar)	10
Temperature °C	-5 ÷ +70
Flow rate at 6 bar with Δp=1 (NI/min)	120
Orifice size (mm)	2.5
Working ports size	M5

TYPE	32 = 3 ways 52 = 5 ways
------	----------------------------

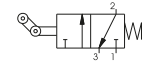

105.32.3.1

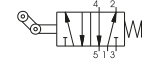

105.52.3.1

3 ways

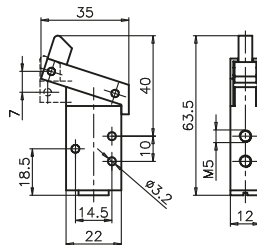

Weight 85 g  
Operating force 6 N

5 ways

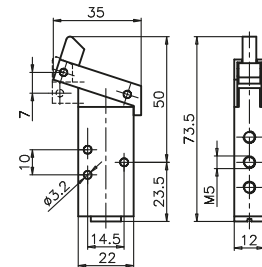

Weight 102 g  
Operating force 6 N

**Lever panel Ø22 - 2 positions**

Coding: 105.1.4/C

**Operational characteristics**

Fluid	Filtered air. No lubrication needed, if applied it shall be continuous
Max working pressure (bar)	10
Temperature °C	-5 ÷ +70
Flow rate at 6 bar with Δp=1 (NI/min)	120
Orifice size (mm)	2.5
Working ports size	M5

TYPE	32 = 3 ways 52 = 5 ways
LEVER COLOR	1 = Red 2 = Black 3 = Green

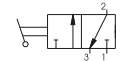

105.32.4/C

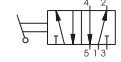

105.52.4/C

3 ways

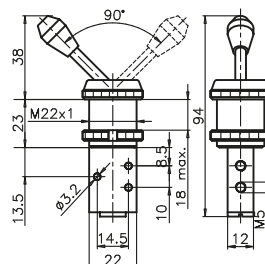

Weight 125 g

5 ways

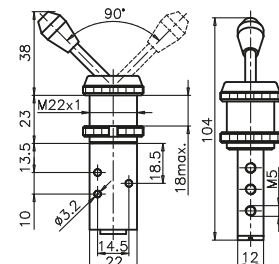

Weight 142 g

**Lever panel Ø30 - 2 positions**

Coding: 105.1.5/C

Operational characteristics	
Fluid	Filtered air. No lubrication needed, if applied it shall be continuous
Max working pressure (bar)	10
Temperature °C	-5 ÷ +70
Flow rate at 6 bar with $\Delta p=1$ (NI/min)	120
Orifice size (mm)	2.5
Working ports size	M5

T	TYPE
	32 = 3 ways 52 = 5 ways
C	LEVER COLOR
	1 = Red 2 = Black 3 = Green

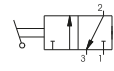

105.32.5/C

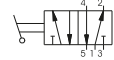

105.52.5/C

3 ways



Weight 165 g

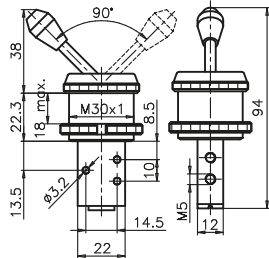

5 ways



Weight 182 g

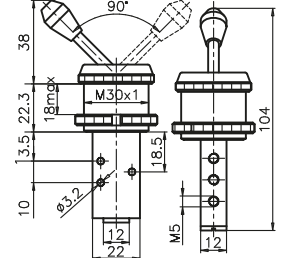

**Push button Ø30 - Spring**

Coding: 105.1.6.1/C

Operational characteristics	
Fluid	Filtered air. No lubrication needed, if applied it shall be continuous
Max working pressure (bar)	10
Temperature °C	-5 ÷ +70
Flow rate at 6 bar with $\Delta p=1$ (NI/min)	120
Orifice size (mm)	2.5
Working ports size	M5

T	TYPE
	32 = 3 ways 52 = 5 ways
C	BUTTON COLOR
	1 = Red 2 = Black 3 = Green

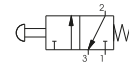

105.32.6.1/C

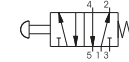

105.52.6.1/C

3 ways



Weight 123 g  
Operating force 14 N

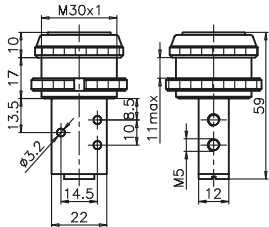

5 ways



Weight 140 g  
Operating force 14 N

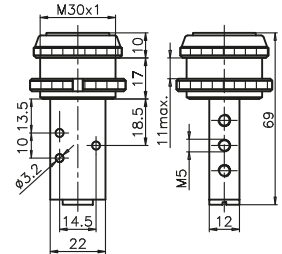

**Push button Ø22 - Spring**

Coding: 105.1.6.2/C

Operational characteristics	
Fluid	Filtered air. No lubrication needed, if applied it shall be continuous
Max working pressure (bar)	10
Temperature °C	-5 ÷ +70
Flow rate at 6 bar with $\Delta p=1$ (NI/min)	120
Orifice size (mm)	2.5
Working ports size	M5

T	TYPE
	32 = 3 ways 52 = 5 ways
C	BUTTON COLOR
	1 = Red 2 = Black 3 = Green

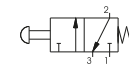

105.32.6.2/C

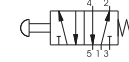

105.52.6.2/C

3 ways



Weight 102 g  
Operating force 14 N

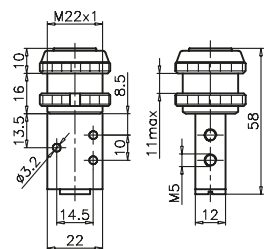

5 ways



Weight 119 g  
Operating force 14 N

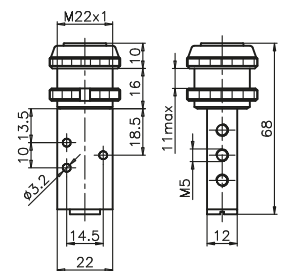

**Push button - Spring**

Coding: 105.1.6.22/©

**Operational characteristics**

Fluid	Filtered air. No lubrication needed, if applied it shall be continuous
Max working pressure (bar)	10
Temperature °C	-5 ÷ +70
Flow rate at 6 bar with Δp=1 (NI/min)	120
Orifice size (mm)	2.5
Working ports size	M5

TYPE	32 = 3 ways 52 = 5 ways
BUTTON COLOR	1 = Red 2 = Black 3 = Green 4 = Yellow

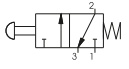

105.32.6.22/©



105.52.6.22/©

3 ways

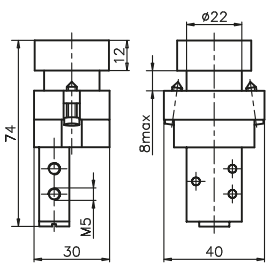

Weight 165 g  
Operating force 14 N

5 ways

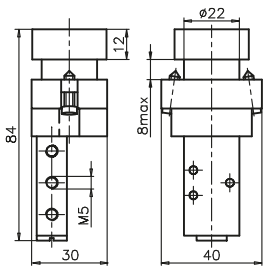

Weight 182 g  
Operating force 14 N

**Raised Push button - Spring**

Coding: 105.1.6.23/©

**Operational characteristics**

Fluid	Filtered air. No lubrication needed, if applied it shall be continuous
Max working pressure (bar)	10
Temperature °C	-5 ÷ +70
Flow rate at 6 bar with Δp=1 (NI/min)	120
Orifice size (mm)	2.5
Working ports size	M5

TYPE	32 = 3 ways 52 = 5 ways
BUTTON COLOR	1 = Red 2 = Black 3 = Green 4 = Yellow

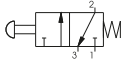

105.32.6.23/©

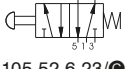

105.52.6.23/©

3 ways

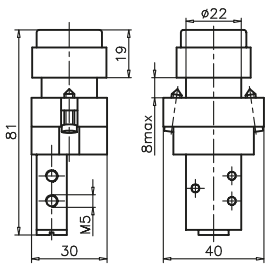

Weight 170 g  
Operating force 14 N

5 ways

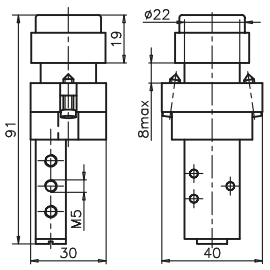

Weight 187 g  
Operating force 14 N

**Switch 2 positions**

Coding: 105.1.6.27

**Operational characteristics**

Fluid	Filtered air. No lubrication needed, if applied it shall be continuous
Max working pressure (bar)	10
Temperature °C	-5 ÷ +70
Flow rate at 6 bar with Δp=1 (NI/min)	120
Orifice size (mm)	2.5
Working ports size	M5

TYPE	32 = 3 ways 52 = 5 ways
------	----------------------------

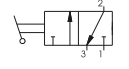

105.32.6.27



105.52.6.27

3 ways

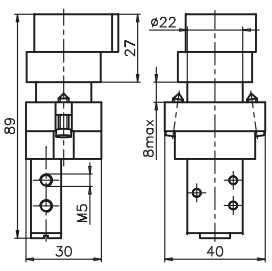

Weight 185 g

5 ways

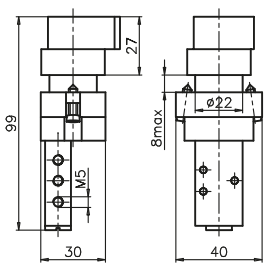

Weight 202 g

**Key switch 2 positions**

Coding: 105.1.6.28

Operational characteristics	
Fluid	Filtered air. No lubrication needed, if applied it shall be continuous
Max working pressure (bar)	10
Temperature °C	-5 ÷ +70
Flow rate at 6 bar with Δp=1 (NI/min)	120
Orifice size (mm)	2.5
Working ports size	M5

T	TYPE
	32 = 3 ways
	52 = 5 ways

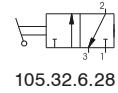

105.32.6.28

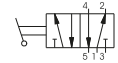

105.52.6.28

3 ways



Weight 215 g

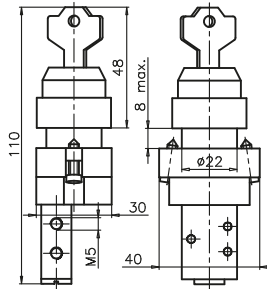

5 ways



Weight 232 g

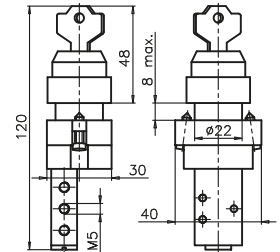

**Palm pushbutton Ø30 - Spring**

Coding: 105.1.7.1/C

Operational characteristics	
Fluid	Filtered air. No lubrication needed, if applied it shall be continuous
Max working pressure (bar)	10
Temperature °C	-5 ÷ +70
Flow rate at 6 bar with Δp=1 (NI/min)	120
Orifice size (mm)	2.5
Working ports size	M5

T	TYPE
	32 = 3 ways
	52 = 5 ways
C	BUTTON COLOR
	1 = Red
	2 = Black
	3 = Green

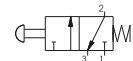

105.32.7.1/C

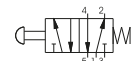

105.52.7.1/C

3 ways



Weight 126 g  
Operating force 14 N

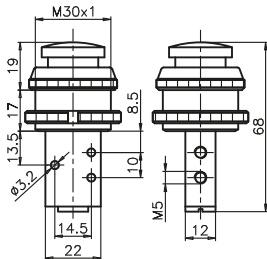

5 ways



Weight 143 g  
Operating force 14 N

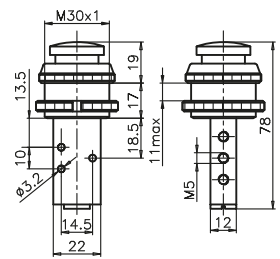

**Palm pushbutton Ø22 - Spring**

Coding: 105.1.7.2/C

Operational characteristics	
Fluid	Filtered air. No lubrication needed, if applied it shall be continuous
Max working pressure (bar)	10
Temperature °C	-5 ÷ +70
Flow rate at 6 bar with Δp=1 (NI/min)	120
Orifice size (mm)	2.5
Working ports size	M5

T	TYPE
	32 = 3 ways
	52 = 5 ways
C	BUTTON COLOR
	1 = Red
	2 = Black
	3 = Green

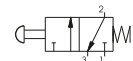

105.32.7.2/C



105.52.7.2/C

3 ways



Weight 103 g  
Operating force 14 N

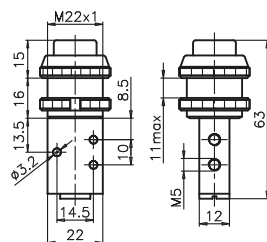

5 ways



Weight 120 g  
Operating force 14 N

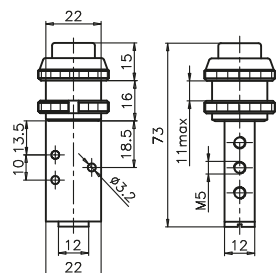

**Push button**

Coding: 105.1.8.1/C

**Operational characteristics**

Fluid	Filtered air. No lubrication needed, if applied it shall be continuous
Max working pressure (bar)	10
Temperature °C	-5 ÷ +70
Flow rate at 6 bar with Δp=1 (NI/min)	120
Orifice size (mm)	2.5
Working ports size	M5

TYPE	32 = 3 ways 52 = 5 ways
BUTTON COLOR	1 = Red 2 = Black 3 = Green



105.32.8.1/C



105.52.8.1/C

3 ways

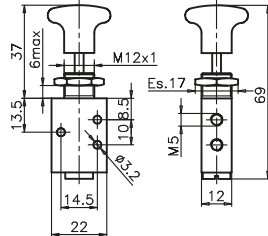

Weight 75 g  
Operating force 14 N

5 ways

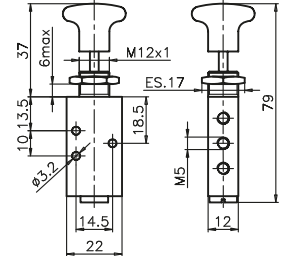

Weight 92 g  
Operating force 14 N

**Push button 2 positions**

Coding: 105.1.8/C

**Operational characteristics**

Fluid	Filtered air. No lubrication needed, if applied it shall be continuous
Max working pressure (bar)	10
Temperature °C	-5 ÷ +70
Flow rate at 6 bar with Δp=1 (NI/min)	120
Orifice size (mm)	2.5
Working ports size	M5

TYPE	32 = 3 ways 52 = 5 ways
BUTTON COLOR	1 = Red 2 = Black 3 = Green



105.32.8/C



105.52.8/C

3 ways

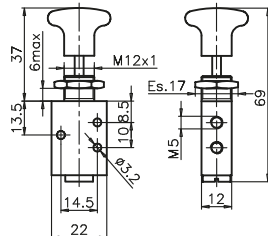

Weight 75 g  
Operating force 14 N

5 ways

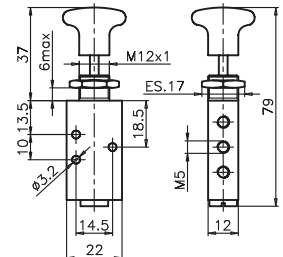

Weight 92 g  
Operating force 14 N

**Whisker - Spring**

Coding: 105.1.9.1

**Operational characteristics**

Fluid	Filtered air. No lubrication needed, if applied it shall be continuous
Max working pressure (bar)	10
Temperature °C	-5 ÷ +70
Flow rate at 6 bar with Δp=1 (NI/min)	120
Orifice size (mm)	2.5
Working ports size	M5

TYPE	32 = 3 ways 52 = 5 ways
------	----------------------------



105.32.9.1



105.52.9.1

3 ways

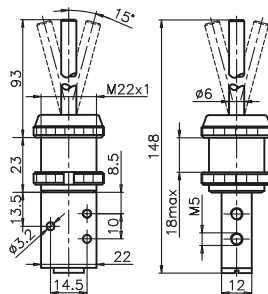

Weight 136 g

5 ways

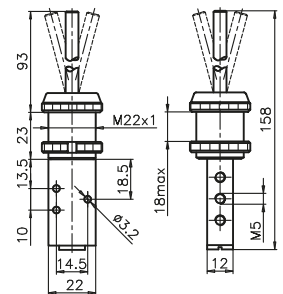

Weight 153 g

Handle with valve

Coding: 105.T.6.A.F

Operational characteristics	
Fluid	Filtered air. No lubrication needed, if applied it shall be continuous
Max working pressure (bar)	10
Temperature °C	-5 ÷ +70
Flow rate at 6 bar with Δp=1 (NI/min)	120
Orifice size (mm)	2.5
Working ports size	M5 - Quick Fitting for Ø4 tube

T	TYPE	F	FUNCTION (only for 3 ways)
	32 = 3 ways		A = Normally Open
	52 = 5 ways		C = Normally Closed
A	FEEDING		
	40 = Left feeding		
	40D = Right feeding		

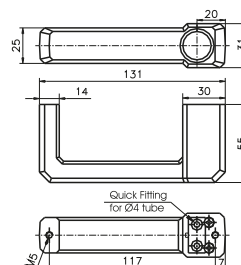

Weight 165 g  
Operating force 14 N

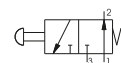

105.32.6.40.Ⓢ

Left feeding

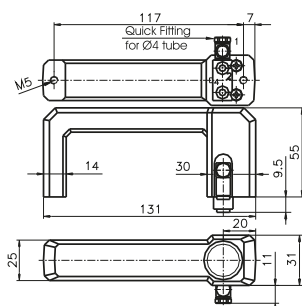

Weight 190 g  
Operating force 14 N

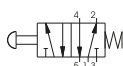

105.52.6.40

Right feeding

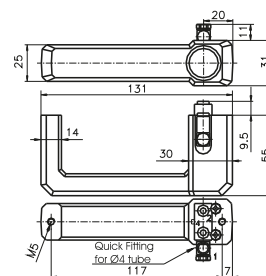

Weight 190 g  
Operating force 14 N

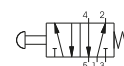

105.52.6.40.Ⓢ



AIR DISTRIBUTION

**Pneumatic - Spring**

Coding: 105.11.1

**Operational characteristics**

Fluid	Filtered air. No lubrication needed, if applied it shall be continuous
Max working pressure (bar)	10
Temperature °C	-5 ÷ +70
Flow rate at 6 bar with Δp=1 (NI/min)	120
Orifice size (mm)	2.5
Working ports size	M5
Pilot ports size	M5

TYPE	
32 = 3 ways	
52 = 5 ways	

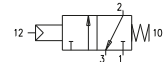

105.32.11.1

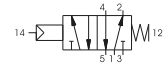

105.52.11.1

3 ways

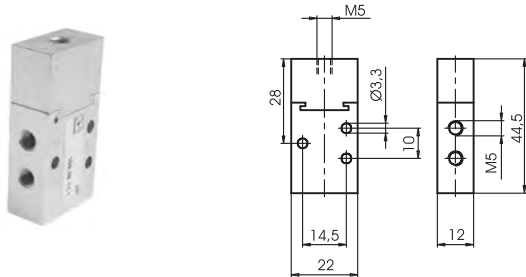

Weight 90 g  
Minimum piloting pressure 2,5 bar

5 ways

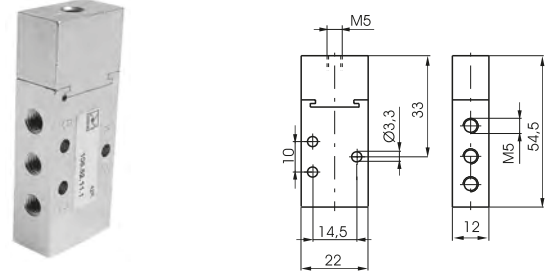

Weight 100 g  
Minimum piloting pressure 2,5 bar

**Pneumatic - Differential external**

Coding: 105.11.12

**Operational characteristics**

Fluid	Filtered air. No lubrication needed, if applied it shall be continuous
Max working pressure (bar)	10
Temperature °C	-5 ÷ +70
Flow rate at 6 bar with Δp=1 (NI/min)	120
Orifice size (mm)	2.5
Working ports size	M5
Pilot ports size	M5

TYPE	
32 = 3 ways	
52 = 5 ways	

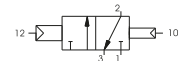

105.32.11.12



105.52.11.12

3 ways

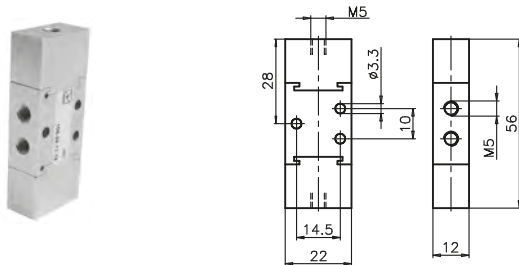

Weight 110 g  
Minimum piloting pressure 2,5 bar

5 ways

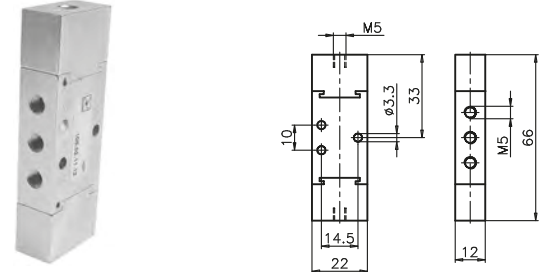

Weight 120 g  
Minimum piloting pressure 2,5 bar

**Pneumatic - Pneumatic**

Coding: 105.11.11

**Operational characteristics**

Fluid	Filtered air. No lubrication needed, if applied it shall be continuous
Max working pressure (bar)	10
Temperature °C	-5 ÷ +70
Flow rate at 6 bar with Δp=1 (NI/min)	120
Orifice size (mm)	2.5
Working ports size	M5
Pilot ports size	M5

TYPE	
32 = 3 ways	
52 = 5 ways	

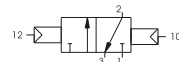

105.32.11.11



105.52.11.11

3 ways

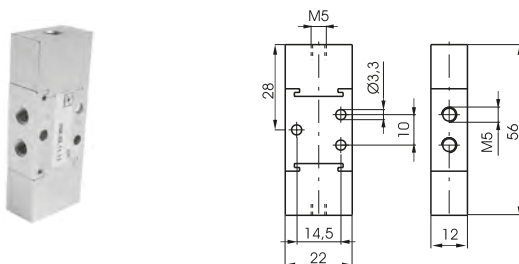

Weight 110 g  
Minimum piloting pressure 2,5 bar

5 ways

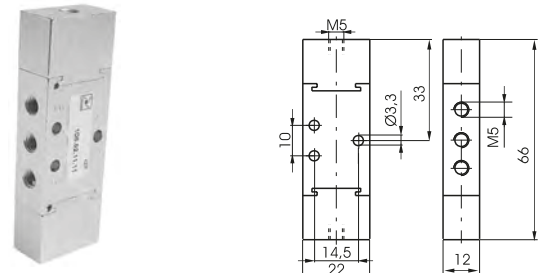

Weight 120 g  
Minimum piloting pressure 2,5 bar





## Series 200

### General

The series 200 consist of a broad range of valves with various type of actuation.

The connections for this series are from G 1/8" to G 1".

Due to their special construction with a balanced spool, these valves can be used interchangeably as 3 ways or 5 ways.

The 3 ways can be used normally closed or normally open and the 5 ways can be fed through the exhausts 3 and 5 with different pressures according to the need.

The spool, as it is moving, isolates the connections without being affected by the inlet pressure.

### Construction characteristics

	G 1/8" - G 1/4" - G 1/2" - G 1"
Body	Aluminium
Operators	Aluminium Technopolymer
Seals	NBR PUR for 212/2
Spacer	Technopolymer Aluminium for G1" (211)
Spools	Steel Aluminium, for 212/2
Springs	Spring steel
Pistons	Technopolymer, for 228 pneumatic command valves Aluminium, for 224, 212, 212/2 e 211 pneumatic command valves

### Use and maintenance

This valves have an average life of 15 million cycles depending on the application and air quality.

Filtered and lubricated air using specified lubricants will reduce the wear of the seals and ensures long and trouble free operation.

Please ensure that the valve is being used according with the manufacturers specification, such as air pressure and temperature.

The exhaust port of the distributor has to be protected in a dusty and dirty environment.

Repair kits including the spool complete with seals are available for overhauling the valves.

However, although this is a simple operation it should be carried out by a competent person.

**ATTENTION:** use hydraulic oil class H for lubrication such as MAGNA GC 32 (Castrol).



AIR DISTRIBUTION

**Tappet - Spring**

Coding: 228. **T**.0.1

Operational characteristics	
Fluid	Filtered air. No lubrication needed, if applied it shall be continuous
Max working pressure (bar)	10
Temperature °C	-5 ÷ +70
Flow rate at 6 bar with Δp=1 (NI/min)	540
Orifice size (mm)	6
Working ports size	G1/8"

TYPE
<b>T</b> 32 = 3 ways
52 = 5 ways

3 ways

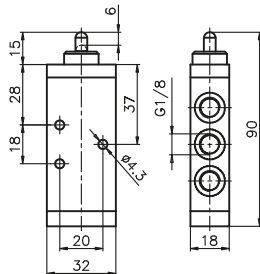

Weight 85 g  
Operating force 33 N

228.32.0.1

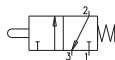

5 ways

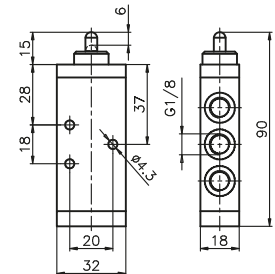

Weight 105 g  
Operating force 33 N

228.52.0.1

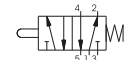

**Tappet panel - Spring**

Coding: 228. **T**.1.1

Operational characteristics	
Fluid	Filtered air. No lubrication needed, if applied it shall be continuous
Max working pressure (bar)	10
Temperature °C	-5 ÷ +70
Flow rate at 6 bar with Δp=1 (NI/min)	540
Orifice size (mm)	6
Working ports size	G1/8"

TYPE
<b>T</b> 32 = 3 ways
52 = 5 ways

3 ways

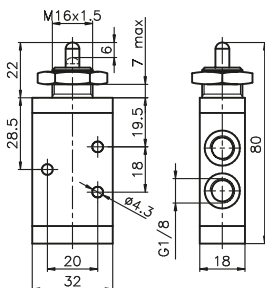

Weight 102 g  
Operating force 33 N

228.32.1.1

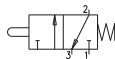

5 ways

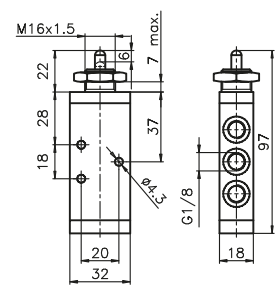

Weight 122 g  
Operating force 33 N

228.52.1.1

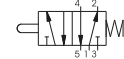

**Lever roller - Spring**

Coding: 228. **T**.2. **V**

Operational characteristics	
Fluid	Filtered air. No lubrication needed, if applied it shall be continuous
Max working pressure (bar)	10
Temperature °C	-5 ÷ +70
Flow rate at 6 bar with Δp=1 (NI/min)	540
Orifice size (mm)	6
Working ports size	G1/8"

TYPE
<b>T</b> 32 = 3 ways
52 = 5 ways

VERSION
<b>V</b> 1 = Plastic roller
1/2 = Metal roller

3 ways

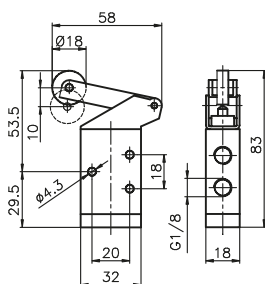

Weight 115 g  
Operating force 15 N

228.32.2. **V**

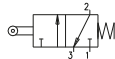

5 ways

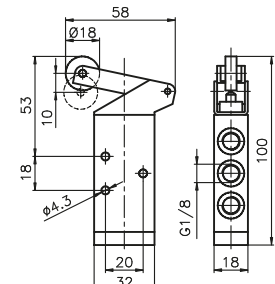

Weight 135 g  
Operating force 15 N

228.52.2. **V**



### Lever roller ball bearing - Spring

Coding: 228.1.2.1/1

Operational characteristics	
Fluid	Filtered air. No lubrication needed, if applied it shall be continuous
Max working pressure (bar)	10
Temperature °C	-5 ÷ +70
Flow rate at 6 bar with $\Delta p=1$ (NI/min)	540
Orifice size (mm)	6
Working ports size	G1/8"

TYPE
32 = 3 ways
52 = 5 ways

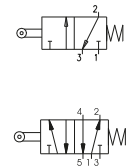

3 ways



Weight 130 g  
Operating force 15 N

228.32.2.1/1

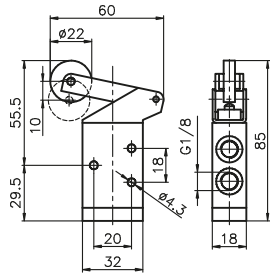

5 ways



Weight 150 g  
Operating force 15 N

228.52.2.1/1

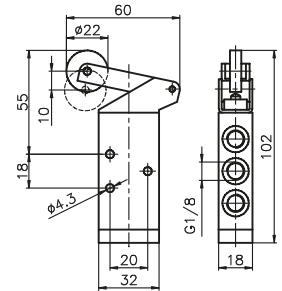

### Lever button - Spring

Coding: 228.1.2.6/C

Operational characteristics	
Fluid	Filtered air. No lubrication needed, if applied it shall be continuous
Max working pressure (bar)	10
Temperature °C	-5 ÷ +70
Flow rate at 6 bar with $\Delta p=1$ (NI/min)	540
Orifice size (mm)	6
Working ports size	G1/8"

TYPE
32 = 3 ways
52 = 5 ways
BUTTON COLOR
1 = Red
2 = Black
3 = Green

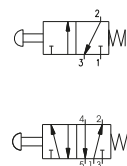

3 ways



Weight 120 g  
Operating force 15 N

228.32.2.6/C

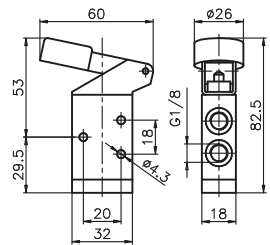

5 ways



Weight 120 g  
Operating force 15 N

228.52.2.6/C

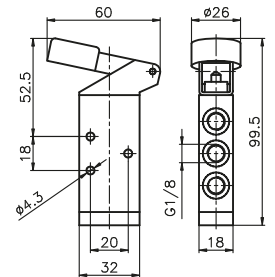

### Switch lateral 2 positions

Coding: 228.1.27

Operational characteristics	
Fluid	Filtered air. No lubrication needed, if applied it shall be continuous
Max working pressure (bar)	10
Temperature °C	-5 ÷ +70
Flow rate at 6 bar with $\Delta p=1$ (NI/min)	540
Orifice size (mm)	6
Working ports size	G1/8"

TYPE
32 = 3 ways
52 = 5 ways

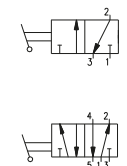

3 ways



Weight 190 g

228.32.27

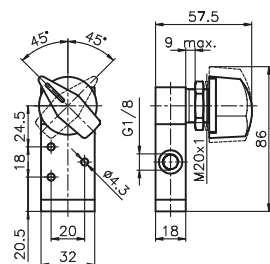

5 ways



Weight 210 g

228.52.27

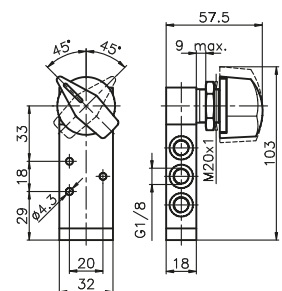

**Lever roller unidirectional - Spring**

Coding: 228.●.3.●

**Operational characteristics**

Fluid	Filtered air. No lubrication needed, if applied it shall be continuous
Max working pressure (bar)	10
Temperature °C	-5 ÷ +70
Flow rate at 6 bar with Δp=1 (NI/min)	540
Orifice size (mm)	6
Working ports size	G1/8"

TYPE	
●	32 = 3 ways
	52 = 5 ways
VERSION	
●	1 = Plastic roller
	1/2 = Metal roller

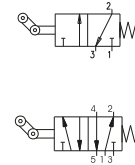

AIR DISTRIBUTION

3 ways

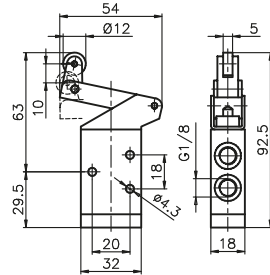

Weight 110 g

228.32.3.●

5 ways

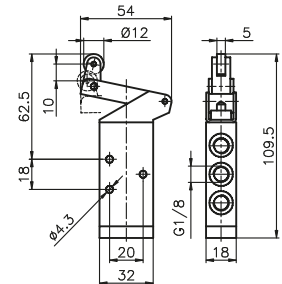

Weight 130 g

228.52.3.●

**Lever roller lateral bidirectional - Spring**

Coding: 228.●.4.1

**Operational characteristics**

Fluid	Filtered air. No lubrication needed, if applied it shall be continuous
Max working pressure (bar)	10
Temperature °C	-5 ÷ +70
Flow rate at 6 bar with Δp=1 (NI/min)	540
Orifice size (mm)	6
Working ports size	G1/8"

TYPE	
●	32 = 3 ways
	52 = 5 ways

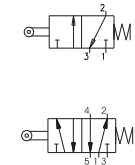

3 ways

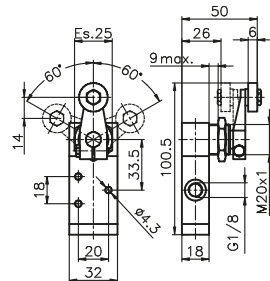

Weight 180 g

228.32.4.1

5 ways

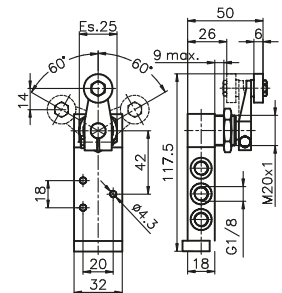

Weight 200 g

228.52.4.1

**Lever sensitive - differential**

Coding: 228.●.4.13

**Operational characteristics**

Fluid	Filtered air. No lubrication needed, if applied it shall be continuous
Max working pressure (bar)	10
Temperature °C	-5 ÷ +70
Flow rate at 6 bar with Δp=1 (NI/min)	540
Orifice size (mm)	6
Working ports size	G1/8"

TYPE	
●	32 = 3 ways
	52 = 5 ways

Minimum rotation angle 11°

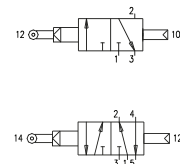

3 ways

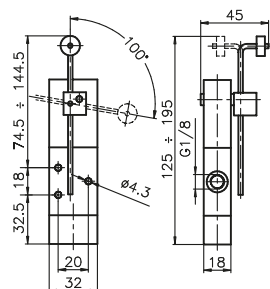

Weight 200 g

Minimum rotation angle 11°

Minimum working pressure 2,5 bar

228.32.4.13

5 ways

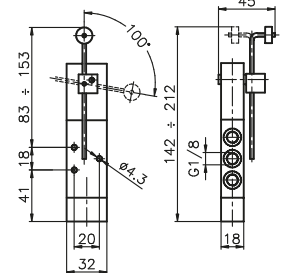

Weight 220 g

Minimum rotation angle 11°

Minimum working pressure 2,5 bar

228.52.4.13

**Lever panel Ø30 - 2 positions**

Coding: 228.1.5/C

Operational characteristics	
Fluid	Filtered air. No lubrication needed, if applied it shall be continuous
Max working pressure (bar)	10
Temperature °C	-5 ÷ +70
Flow rate at 6 bar with Δp=1 (NI/min)	540
Orifice size (mm)	6
Working ports size	G1/8"

T	TYPE
	32 = 3 ways 52 = 5 ways
C	LEVER COLOR
	1 = Red 2 = Black 3 = Green

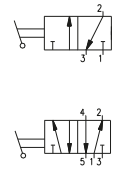

3 ways



Weight 198 g

228.32.5/C

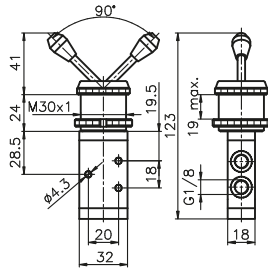

5 ways



Weight 218 g

228.52.5/C

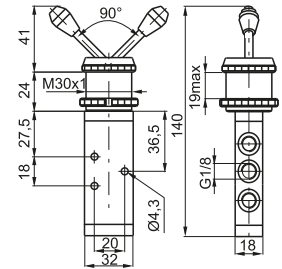

**Frontal lever - 2 positions**

Coding: 228.1.55/C

Operational characteristics	
Fluid	Filtered air. No lubrication needed, if applied it shall be continuous
Max working pressure (bar)	10
Temperature °C	-5 ÷ +70
Flow rate at 6 bar with Δp=1 (NI/min)	540
Orifice size (mm)	6
Working ports size	G1/8"

T	TYPE
	32 = 3 ways 52 = 5 ways
C	LEVER COLOR
	1 = Red 2 = Black 3 = Green

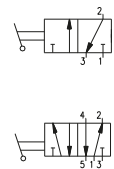

3 ways



Weight 115 g

228.32.55/C

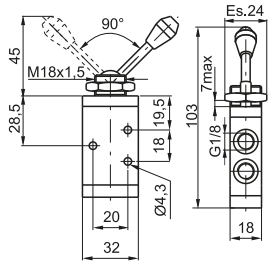

5 ways



Weight 135 g

228.52.55/C

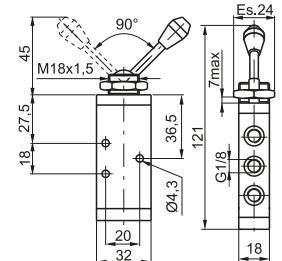

**Push button Ø 30 - spring**

Coding: 228.1.6.1/C

Operational characteristics	
Fluid	Filtered air. No lubrication needed, if applied it shall be continuous
Max working pressure (bar)	10
Temperature °C	-5 ÷ +70
Flow rate at 6 bar with Δp=1 (NI/min)	540
Orifice size (mm)	6
Working ports size	G1/8"

T	TYPE
	32 = 3 ways 52 = 5 ways
C	BUTTON COLOR
	1 = Red 2 = Black 3 = Green



3 ways



Weight 155 g  
Operating force 33 N

228.32.6.1/C

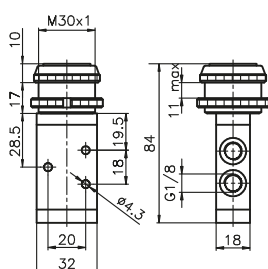

5 ways



Weight 175 g  
Operating force 33 N

228.52.6.1/C

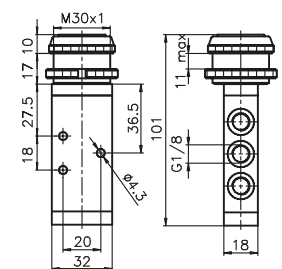

**Sensitive push button Ø30 - differential**

Coding: 228.1.6.13/C

**Operational characteristics**

Fluid	Filtered air. No lubrication needed, if applied it shall be continuous
Max working pressure (bar)	10
Temperature °C	-5 ÷ +70
Flow rate at 6 bar with Δp=1 (NI/min)	540
Orifice size (mm)	6
Working ports size	G1/8"

TYPE	32 = 3 ways 52 = 5 ways
BUTTON COLOR	1 = Red 2 = Black 3 = Green

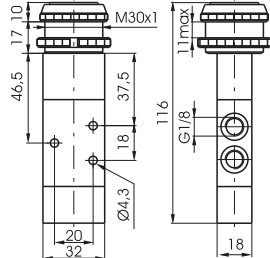
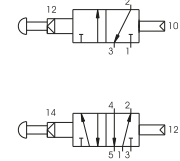

Weight 197 g  
Operating force 18,5 N (at 6 bar)

228.32.6.13/C

5 ways

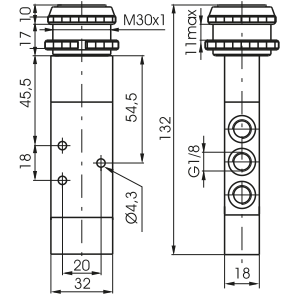

Weight 217 g  
Operating force 18,5 N (at 6 bar)

228.52.6.13/C

**Push button - Spring**

Coding: 228.1.6.22/C

**Operational characteristics**

Fluid	Filtered air. No lubrication needed, if applied it shall be continuous
Max working pressure (bar)	10
Temperature °C	-5 ÷ +70
Flow rate at 6 bar with Δp=1 (NI/min)	540
Orifice size (mm)	6
Working ports size	G1/8"

TYPE	32 = 3 ways 52 = 5 ways
BUTTON COLOR	1 = Red 2 = Black 3 = Green 4 = Yellow

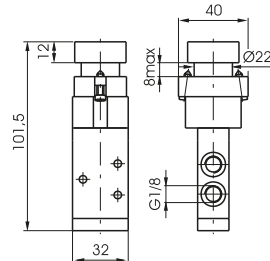
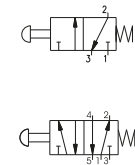

Weight 225 g  
Operating force 33 N

228.32.6.22/C

5 ways

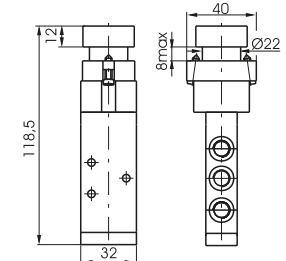

Weight 245 g  
Operating force 33 N

228.52.6.22/C

**Raised push button Ø22 - Spring**

Coding: 228.1.6.23/C

**Operational characteristics**

Fluid	Filtered air. No lubrication needed, if applied it shall be continuous
Max working pressure (bar)	10
Temperature °C	-5 ÷ +70
Flow rate at 6 bar with Δp=1 (NI/min)	540
Orifice size (mm)	6
Working ports size	G1/8"

TYPE	32 = 3 ways 52 = 5 ways
BUTTON COLOR	1 = Red 2 = Black 3 = Green 4 = Yellow

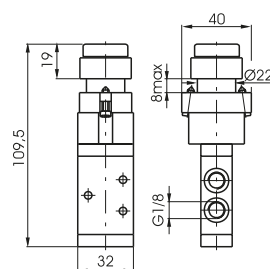
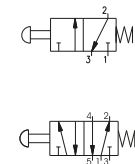

Weight 230 g  
Operating force 33 N

228.32.6.23/C

5 ways

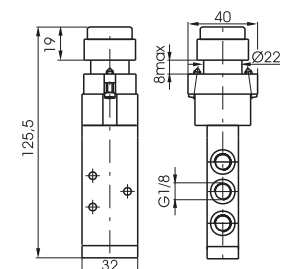

Weight 250 g  
Operating force 33 N

228.52.6.23/C

1 AIR DISTRIBUTION

**Push button Ø22 - 2 positions**

Coding: 228.1.6.25

Operational characteristics	
Fluid	Filtered air. No lubrication needed, if applied it shall be continuous
Max working pressure (bar)	10
Temperature °C	-5 ÷ +70
Flow rate at 6 bar with Δp=1 (NI/min)	540
Orifice size (mm)	6
Working ports size	G1/8"

TYPE	
32	= 3 ways
52	= 5 ways

Emergency - Rotate to unlock

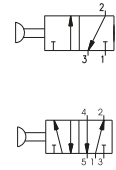

3 ways



Weight 235 g  
Operating force 33 N

228.32.6.25

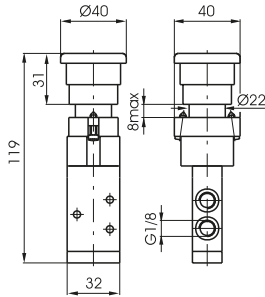

5 ways



Weight 235 g  
Operating force 33 N

228.52.6.25

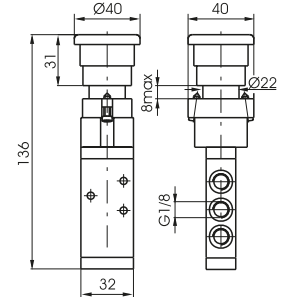

**Switch 2 positions**

Coding: 228.1.6.27

Operational characteristics	
Fluid	Filtered air. No lubrication needed, if applied it shall be continuous
Max working pressure (bar)	10
Temperature °C	-5 ÷ +70
Flow rate at 6 bar with Δp=1 (NI/min)	540
Orifice size (mm)	6
Working ports size	G1/8"

TYPE	
32	= 3 ways
52	= 5 ways

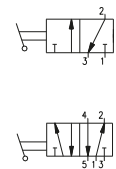

3 ways



Weight 230 g

228.32.6.27

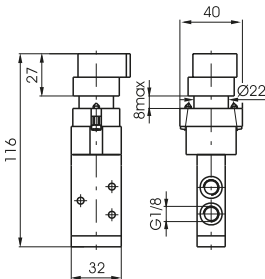

5 ways



Weight 250 g

228.52.6.27

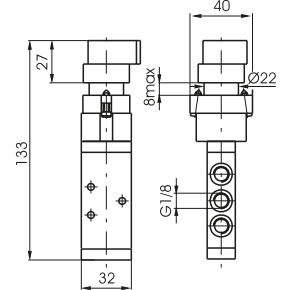

**Key switch 2 positions**

Coding: 228.1.6.28

Operational characteristics	
Fluid	Filtered air. No lubrication needed, if applied it shall be continuous
Max working pressure (bar)	10
Temperature °C	-5 ÷ +70
Flow rate at 6 bar with Δp=1 (NI/min)	540
Orifice size (mm)	6
Working ports size	G1/8"

TYPE	
32	= 3 ways
52	= 5 ways

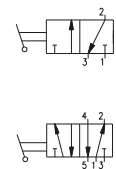

3 ways



Weight 230 g

228.32.6.28

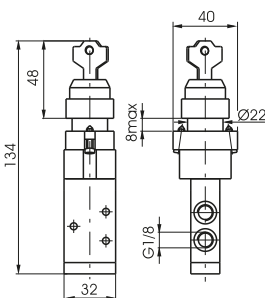

5 ways



Weight 250 g

228.52.6.28

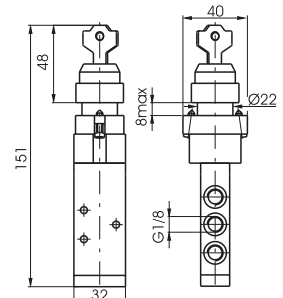



AIR DISTRIBUTION

**Palm push button Ø30 2 positions**

Coding: 228.1.7.1/C

Operational characteristics	
Fluid	Filtered air. No lubrication needed, if applied it shall be continuous
Max working pressure (bar)	10
Temperature °C	-5 ÷ +70
Flow rate at 6 bar with Δp=1 (NI/min)	540
Orifice size (mm)	6
Working ports size	G1/8"

TYPE	32 = 3 ways 52 = 5 ways
BUTTON COLOR	1 = Red 2 = Black 3 = Green

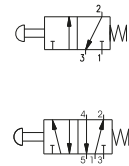

3 ways

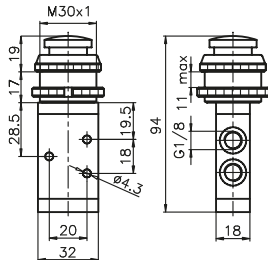

Weight 148 g

228.32.7.1/C

5 ways

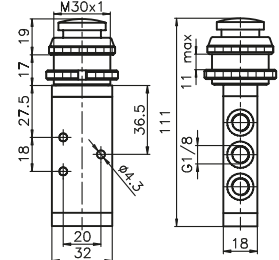

Weight 168 g

228.52.7.1/C

**Push button - Spring**

Coding: 228.1.8.1/C

Operational characteristics	
Fluid	Filtered air. No lubrication needed, if applied it shall be continuous
Max working pressure (bar)	10
Temperature °C	-5 ÷ +70
Flow rate at 6 bar with Δp=1 (NI/min)	540
Orifice size (mm)	6
Working ports size	G1/8"

TYPE	32 = 3 ways 52 = 5 ways
BUTTON COLOR	1 = Red 2 = Black 3 = Green

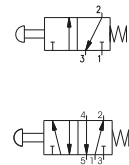

3 ways

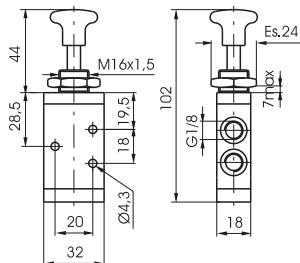

Weight 120 g

228.32.8.1/C

5 ways

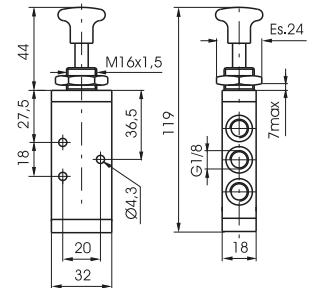

Weight 140 g

228.52.8.1/C

**Push button 2 positions**

Coding: 228.1.8/C

Operational characteristics	
Fluid	Filtered air. No lubrication needed, if applied it shall be continuous
Max working pressure (bar)	10
Temperature °C	-5 ÷ +70
Flow rate at 6 bar with Δp=1 (NI/min)	540
Orifice size (mm)	6
Working ports size	G1/8"

TYPE	32 = 3 ways 52 = 5 ways
BUTTON COLOR	1 = Red 2 = Black 3 = Green

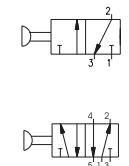

3 ways

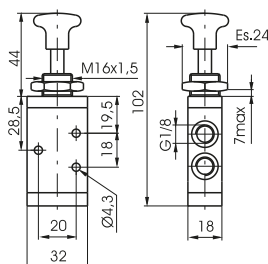

Weight 120 g

228.32.8/C

5 ways

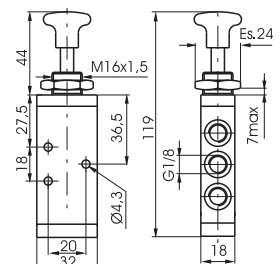

Weight 140 g

228.52.8/C



**Lever lateral - Spring**

Coding: 228.1.9.1/C

Operational characteristics	
Fluid	Filtered air. No lubrication needed, if applied it shall be continuous
Max working pressure (bar)	10
Temperature °C	-5 ÷ +70
Flow rate at 6 bar with Δp=1 (NI/min)	540
Orifice size (mm)	6
Working ports size	G1/8"

<b>T</b>	TYPE
	32 = 3 ways
	52 = 5 ways
<b>C</b>	LEVER COLOR
	1 = Red
	2 = Black
	3 = Green

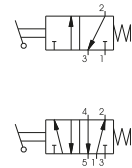

3 ways



Weight 140 g

228.32.9.1/C

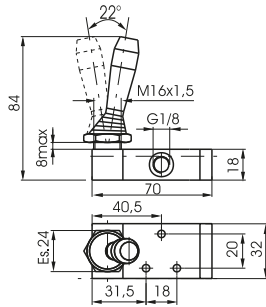

5 ways



Weight 160 g

228.52.9.1/C

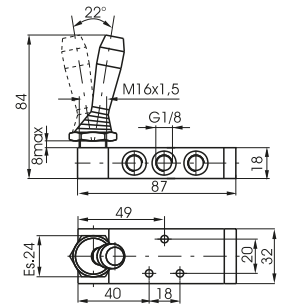

**Lever lateral 2 positions**

Coding: 228.1.9/C

Operational characteristics	
Fluid	Filtered air. No lubrication needed, if applied it shall be continuous
Max working pressure (bar)	10
Temperature °C	-5 ÷ +70
Flow rate at 6 bar with Δp=1 (NI/min)	540
Orifice size (mm)	6
Working ports size	G1/8"

<b>T</b>	TYPE
	32 = 3 ways
	52 = 5 ways
<b>C</b>	LEVER COLOR
	1 = Red
	2 = Black
	3 = Green

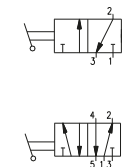

3 ways



Weight 140 g

228.32.9/C

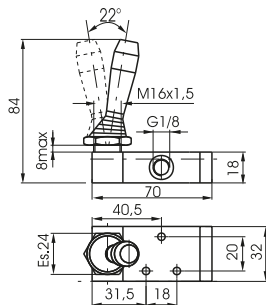

5 ways



Weight 160 g

228.52.9/C

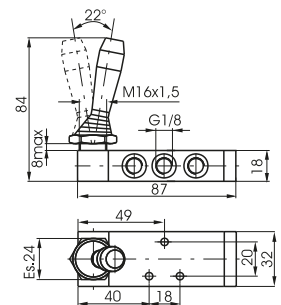

**Pedal aluminium 2 positions**

Coding: 228.1.10

Operational characteristics	
Fluid	Filtered air. No lubrication needed, if applied it shall be continuous
Max working pressure (bar)	10
Temperature °C	-5 ÷ +70
Flow rate at 6 bar with Δp=1 (NI/min)	540
Orifice size (mm)	6
Working ports size	G1/8"

<b>T</b>	TYPE
	32 = 3 ways
	52 = 5 ways

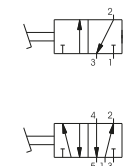

3 ways



Weight 790 g

228.32.10

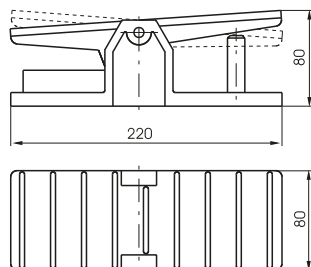

5 ways



Weight 810 g

228.52.10

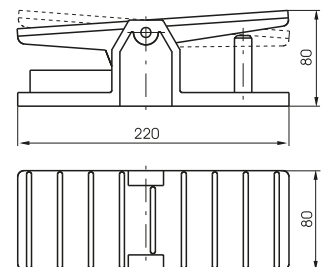

**Pedal aluminium - Spring**

Coding: 228.Ⓣ.10.1

**Operational characteristics**

Fluid	Filtered air. No lubrication needed, if applied it shall be continuous
Max working pressure (bar)	10
Temperature °C	-5 ÷ +70
Flow rate at 6 bar with Δp=1 (NI/min)	540
Orifice size (mm)	6
Working ports size	G1/8"

TYPE	
Ⓣ 32 = 3 ways	
52 = 5 ways	

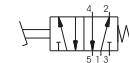
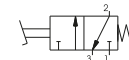

3 ways

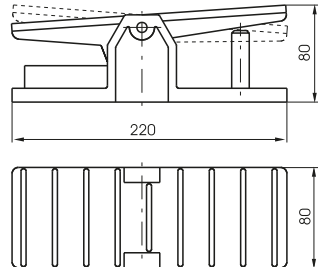

Weight 790 g

228.32.10.1

5 ways

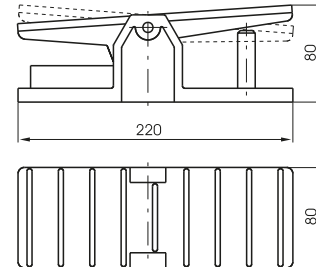

Weight 810 g

228.52.10.1

**Pedal protected - Spring**

Coding: 228.Ⓣ.10.Ⓥ

**Operational characteristics**

Fluid	Filtered air. No lubrication needed, if applied it shall be continuous
Max working pressure (bar)	10
Temperature °C	-5 ÷ +70
Flow rate at 6 bar with Δp=1 (NI/min)	540
Orifice size (mm)	6
Working ports size	G1/8"

TYPE	
Ⓣ 32 = 3 ways	
52 = 5 ways	
VERSION	
Ⓥ 1/1 = Standard version	
2/1 = without safety device	

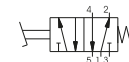
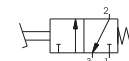

3 ways

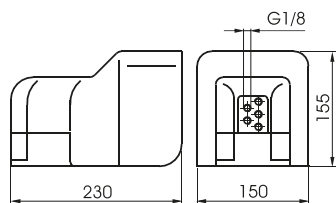

Weight 1120 g

228.32.10.Ⓥ

5 ways

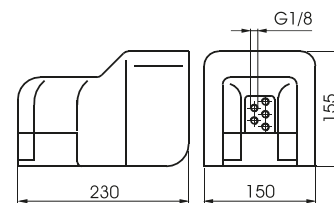

Weight 1120 g

228.52.10.Ⓥ

**Pedal protected 2 positions**

Coding: 228.Ⓣ.10/1

**Operational characteristics**

Fluid	Filtered air. No lubrication needed, if applied it shall be continuous
Max working pressure (bar)	10
Temperature °C	-5 ÷ +70
Flow rate at 6 bar with Δp=1 (NI/min)	540
Orifice size (mm)	6
Working ports size	G1/8"

TYPE	
Ⓣ 32 = 3 ways	
52 = 5 ways	

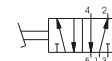
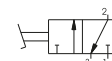

3 ways

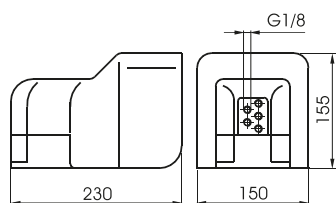

Weight 1120 g

228.32.10/1

5 ways

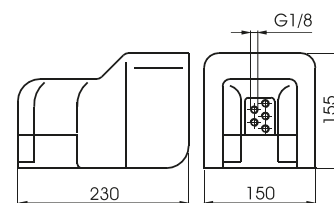

Weight 1120 g

228.52.10/1

**Pedal plastic miniaturized - Spring**

Coding: 228.52.10.F

Operational characteristics	
Fluid	Filtered air. No lubrication needed, if applied it shall be continuous
Max working pressure (bar)	10
Temperature °C	-5 ÷ +70
Flow rate at 6 bar with $\Delta p=1$ (NI/min)	540
Orifice size (mm)	6
Working ports size	G1/8"

FUNCTION	
F	1P = Standard version
	1PX = Stainless steel spool

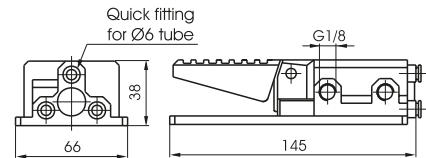

Weight 230 g



**Lever lateral spring centre 3 positions**

Coding: 228.53.F.9.1/C

Operational characteristics	
Fluid	Filtered air. No lubrication needed, if applied it shall be continuous
Max working pressure (bar)	10
Temperature °C	-5 ÷ +70
Flow rate at 6 bar with $\Delta p=1$ (NI/min)	540
Orifice size (mm)	6
Working ports size	G1/8"

FUNCTION	
F	31 = Closed centres
	32 = Open centres
	33 = Pressured centres
LEVER COLOR	
C	1 = Red
	2 = Black
	3 = Green

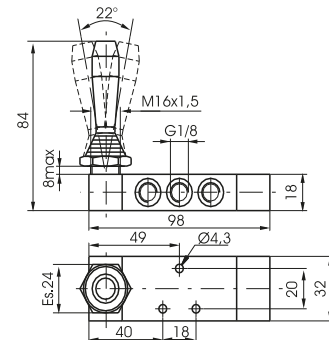
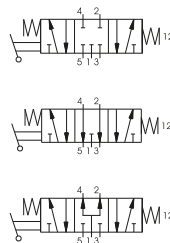

Weight 190 g

**Lever lateral 3 positions detent**

Coding: 228.53.F.9/C

Operational characteristics	
Fluid	Filtered air. No lubrication needed, if applied it shall be continuous
Max working pressure (bar)	10
Temperature °C	-5 ÷ +70
Flow rate at 6 bar with $\Delta p=1$ (NI/min)	540
Orifice size (mm)	6
Working ports size	G1/8"

FUNCTION	
F	31 = Closed centres
	32 = Open centres
	33 = Pressured centres
LEVER COLOR	
C	1 = Red
	2 = Black
	3 = Green

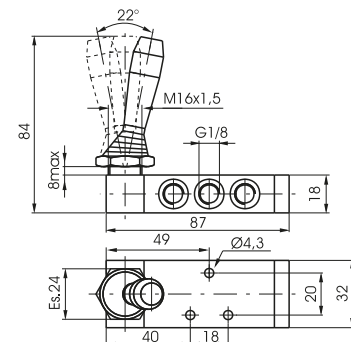
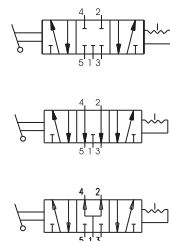

Weight 160 g



1  
AIR DISTRIBUTION

**Lever central (spring 3 pos.) Operator, Levar, Spole in Technopolymer**

**Coding:** 228.53.32.99P/Ⓒ

Operational characteristics	
Fluid	Filtered air. No lubrication needed, if applied it shall be continuous
Max working pressure (bar)	10
Temperature °C	-5 ÷ +70
Flow rate at 6 bar with Δp=1 (NI/min)	410
Orifice size (mm)	6
Working ports size	G1/8"

LEVER COLOR	
Ⓒ 1	= Red
2	= Black



Weight 140 g

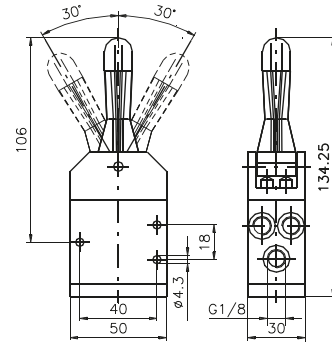
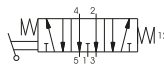

**Lever central (spring 3 pos.) Levar in Technopolymer**

**Coding:** 228.53.32.99/Ⓒ

Operational characteristics	
Fluid	Filtered air. No lubrication needed, if applied it shall be continuous
Max working pressure (bar)	10
Temperature °C	-5 ÷ +70
Flow rate at 6 bar with Δp=1 (NI/min)	410
Orifice size (mm)	6
Working ports size	G1/8"

LEVER COLOR	
Ⓒ 1	= Red
2	= Black



Weight 140 g

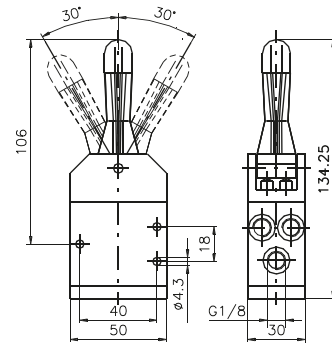

**Lever central Metal (spring 3 pos.) One position stable**

**Coding:** 228.53.32.99/Ⓒ.S

Operational characteristics	
Fluid	Filtered air. No lubrication needed, if applied it shall be continuous
Max working pressure (bar)	10
Temperature °C	-5 ÷ +70
Flow rate at 6 bar with Δp=1 (NI/min)	410
Orifice size (mm)	6
Working ports size	G1/8"

LEVER COLOR	
Ⓒ 1	= Red
2	= Black



Weight 140 g

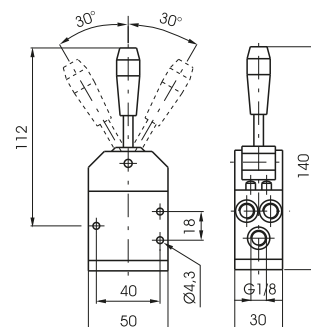

**Lever central Metal**

Coding: 228.53.32.99.F/C

Operational characteristics	
Fluid	Filtered air. No lubrication needed, if applied it shall be continuous
Max working pressure (bar)	10
Temperature °C	-5 ÷ +70
Flow rate at 6 bar with Δp=1 (NI/min)	410
Orifice size (mm)	6
Working ports size	G1/8"

F	FUNCTION
	2 = 2 Stable positions
	3 = 3 pos. stable
C	LEVER COLOR
	1 = Red 2 = Black



Weight 140 g

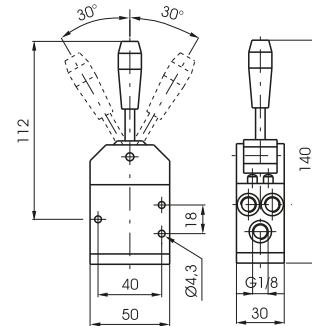
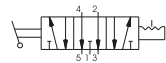
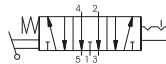

1  
AIR DISTRIBUTION

**Pedal - Spring 3 positions**

Coding: 228.53.F.10.1

Operational characteristics	
Fluid	Filtered air. No lubrication needed, if applied it shall be continuous
Max working pressure (bar)	10
Temperature °C	-5 ÷ +70
Flow rate at 6 bar with Δp=1 (NI/min)	410
Orifice size (mm)	6
Working ports size	G1/8"

F	FUNCTION
	31 = Closed centres
	32 = Open centres



Weight 810 g

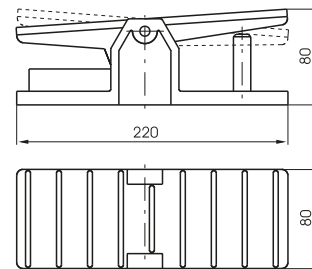
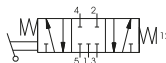



**Pneumatic - Spring**

Coding: 228.11.1

**Operational characteristics**

Fluid	Filtered air. No lubrication needed, if applied it shall be continuous
Max working pressure (bar)	10
Temperature °C	-5 ÷ +70
Flow rate at 6 bar with Δp=1 (NI/min)	540
Orifice size (mm)	6
Working ports size	G1/8"
Pilot ports size	G1/8"

TYPE
① 32 = 3 ways
52 = 5 ways

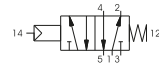
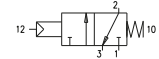

3 ways

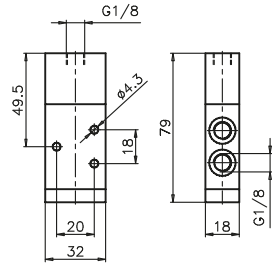

Weight 110 g  
Minimum piloting pressure 2,5 bar

228.32.11.1

5 ways

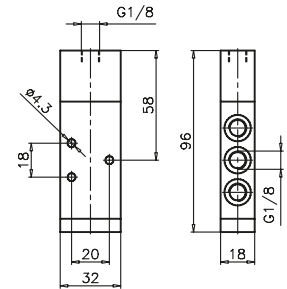

Weight 130 g  
Minimum piloting pressure 2,5 bar

228.52.11.1

**Pneumatic - Differential external**

Coding: 228.11.12

**Operational characteristics**

Fluid	Filtered air. No lubrication needed, if applied it shall be continuous
Max working pressure (bar)	10
Temperature °C	-5 ÷ +70
Flow rate at 6 bar with Δp=1 (NI/min)	540
Orifice size (mm)	6
Working ports size	G1/8"
Pilot ports size	G1/8"

TYPE
① 32 = 3 ways
52 = 5 ways

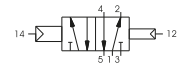
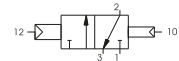

3 ways

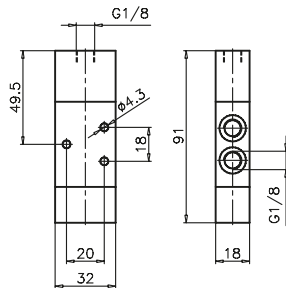

Weight 140 g  
Minimum piloting pressure 2,5 bar

228.32.11.12

5 ways

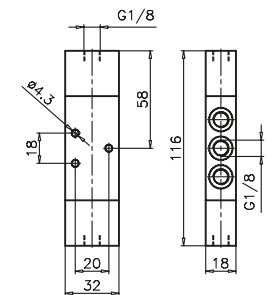

Weight 160 g  
Minimum piloting pressure 2,5 bar

228.52.11.12

**Pneumatic - Differential self aligned**

Coding: 228.11.12/1

**Operational characteristics**

Fluid	Filtered air. No lubrication needed, if applied it shall be continuous
Max working pressure (bar)	10
Temperature °C	-5 ÷ +70
Flow rate at 6 bar with Δp=1 (NI/min)	540
Orifice size (mm)	6
Working ports size	G1/8"
Pilot ports size	G1/8"

TYPE
① 32 = 3 ways
52 = 5 ways

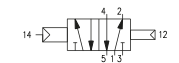
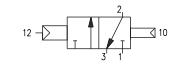

3 ways

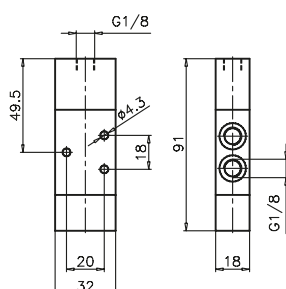

Weight 130 g  
Minimum piloting pressure 2,5 bar

228.32.11.12/1

5 ways

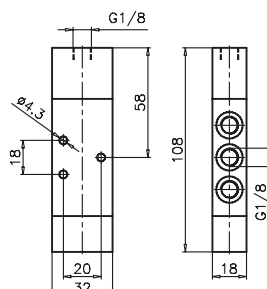

Weight 150 g  
Minimum piloting pressure 2,5 bar

228.52.11.12/1

AIR DISTRIBUTION

**Pneumatic - Pneumatic**

Coding: 228.1.11.11

Operational characteristics	
Fluid	Filtered air. No lubrication needed, if applied it shall be continuous
Max working pressure (bar)	10
Temperature °C	-5 ÷ +70
Flow rate at 6 bar with Δp=1 (NI/min)	540
Orifice size (mm)	6
Working ports size	G1/8"
Pilot ports size	G1/8"

TYPE	
32	= 3 ways
52	= 5 ways

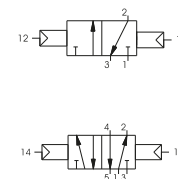

3 ways

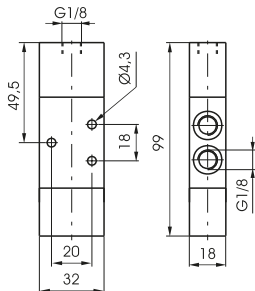

Weight 140 g  
Minimum piloting pressure 2 bar

228.32.11.11

5 ways

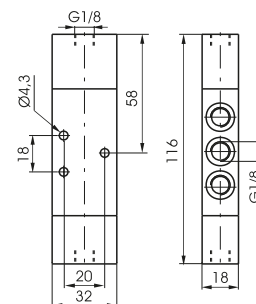

Weight 160 g  
Minimum piloting pressure 2 bar

228.52.11.11

**Amplified pneumatic - Spring**

Coding: 228.1.13.1

Operational characteristics	
Fluid	Filtered air. No lubrication needed, if applied it shall be continuous
Max working pressure (bar)	10
Temperature °C	-5 ÷ +70
Flow rate at 6 bar with Δp=1 (NI/min)	540
Orifice size (mm)	6
Working ports size	G1/8"
Pilot ports size	G1/8"

TYPE	
32	= 3 ways
52	= 5 ways

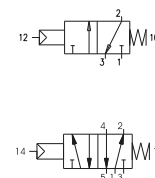

3 ways

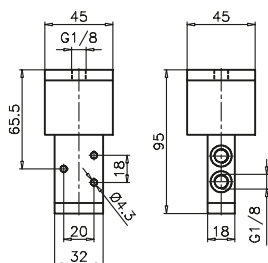

Weight 260 g  
Minimum piloting pressure 0,5 bar

228.32.13.1

5 ways

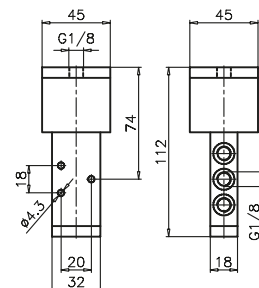

Weight 290 g  
Minimum piloting pressure 0,5 bar

228.52.13.1

**Pneumatic - Pneumatic 5 ways 3 connections**

Coding: 228.53.F.11.11

Operational characteristics	
Fluid	Filtered air. No lubrication needed, if applied it shall be continuous
Max working pressure (bar)	10
Temperature °C	-5 ÷ +70
Flow rate at 6 bar with Δp=1 (NI/min)	410
Orifice size (mm)	6
Working ports size	G1/8"
Pilot ports size	G1/8"

FUNCTION	
31	= Closed centres
32	= Open centres
33	= Pressured centres

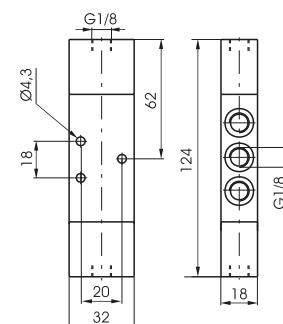
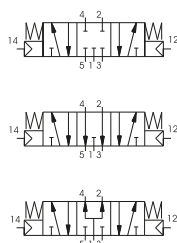

Weight 180 g  
Minimum piloting pressure 3 bar

228.53.F.11.11

**Tappet panel - Spring**

Coding: 224.1.1

**Operational characteristics**

Fluid	Filtered air. No lubrication needed, if applied it shall be continuous
Max working pressure (bar)	10
Temperature °C	-5 ÷ +70
Flow rate at 6 bar with Δp=1 (NI/min)	1360
Orifice size (mm)	8
Working ports size	G1/4"

TYPE
① 32 = 3 ways
52 = 5 ways

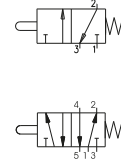

3 ways

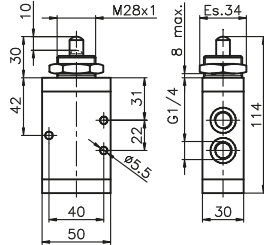

Weight 370 g  
Operating force 71,5 N

224.32.1.1

5 ways

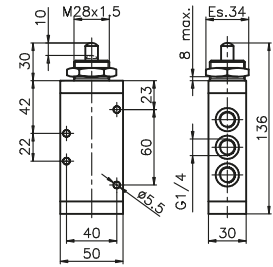

Weight 455 g  
Operating force 71,5 N

224.52.1.1

**Lever roller - Spring**

Coding: 224.2.1

**Operational characteristics**

Fluid	Filtered air. No lubrication needed, if applied it shall be continuous
Max working pressure (bar)	10
Temperature °C	-5 ÷ +70
Flow rate at 6 bar with Δp=1 (NI/min)	1360
Orifice size (mm)	8
Working ports size	G1/4"

TYPE
① 32 = 3 ways
52 = 5 ways

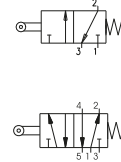

3 ways

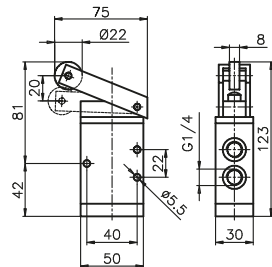

Weight 510 g  
Operating force 35 N

224.32.2.1

5 ways

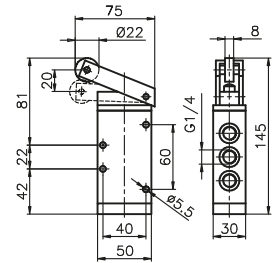

Weight 595 g  
Operating force 35 N

224.52.2.1

**Lever roller unidirectional - Spring**

Coding: 224.3.1

**Operational characteristics**

Fluid	Filtered air. No lubrication needed, if applied it shall be continuous
Max working pressure (bar)	10
Temperature °C	-5 ÷ +70
Flow rate at 6 bar with Δp=1 (NI/min)	1360
Orifice size (mm)	8
Working ports size	G1/4"

TYPE
① 32 = 3 ways
52 = 5 ways

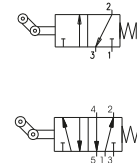

3 ways

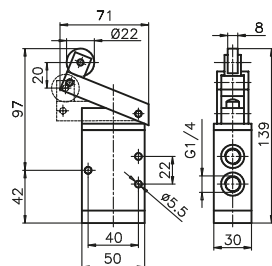

Weight 525 g  
Operating force 35 N

224.32.3.1

5 ways

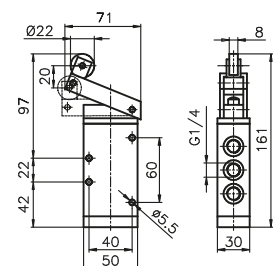

Weight 610 g  
Operating force 35 N

224.52.3.1



**Push button - Spring**

Coding: 224.1.8.1

Operational characteristics	
Fluid	Filtered air. No lubrication needed, if applied it shall be continuous
Max working pressure (bar)	10
Temperature °C	-5 ÷ +70
Flow rate at 6 bar with Δp=1 (NI/min)	1360
Orifice size (mm)	8
Working ports size	G1/4"

TYPE	
32	= 3 ways
52	= 5 ways

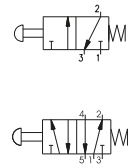

3 ways



Weight 395 g  
Operating force 71,5 N

224.32.8.1

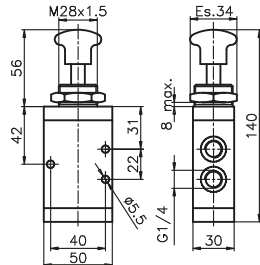

5 ways



Weight 480 g  
Operating force 71,5 N

224.52.8.1

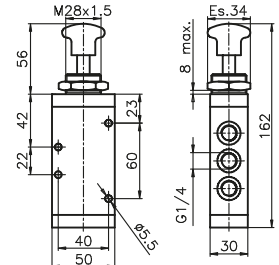

**Push button 2 positions**

Coding: 224.1.8

Operational characteristics	
Fluid	Filtered air. No lubrication needed, if applied it shall be continuous
Max working pressure (bar)	10
Temperature °C	-5 ÷ +70
Flow rate at 6 bar with Δp=1 (NI/min)	1360
Orifice size (mm)	8
Working ports size	G1/4"

TYPE	
32	= 3 ways
52	= 5 ways

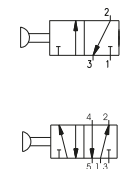

3 ways



Weight 385 g  
Operating force 13 N

224.32.8

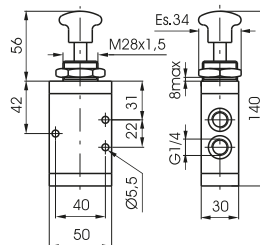

5 ways



Weight 470 g  
Operating force 13 N

224.52.8

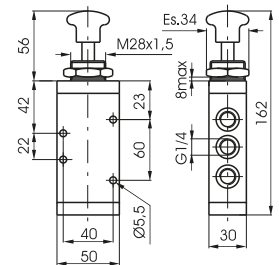

**Lever lateral - Spring**

Coding: 224.1.9.1/C

Operational characteristics	
Fluid	Filtered air. No lubrication needed, if applied it shall be continuous
Max working pressure (bar)	10
Temperature °C	-5 ÷ +70
Flow rate at 6 bar with Δp=1 (NI/min)	1360
Orifice size (mm)	8
Working ports size	G1/4"

TYPE	
32	= 3 ways
52	= 5 ways
LEVER COLOR	
1	= Red
2	= Black
3	= Green

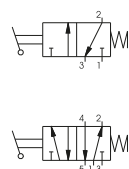

3 ways



Weight 520 g

224.32.9.1/C

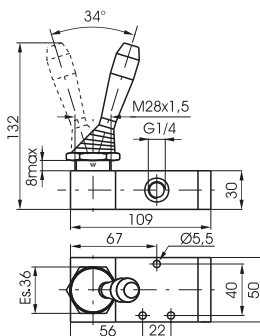

5 ways



Weight 605 g

224.52.9.1/C

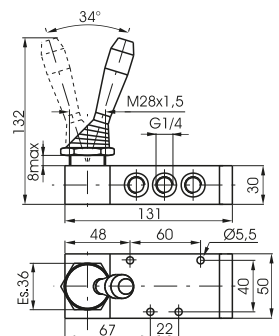



**Lever lateral 2 positions**

Coding: 224.●.9/●

**Operational characteristics**

Fluid	Filtered air. No lubrication needed, if applied it shall be continuous
Max working pressure (bar)	10
Temperature °C	-5 ÷ +70
Flow rate at 6 bar with Δp=1 (NI/min)	1360
Orifice size (mm)	8
Working ports size	G1/4"

TYPE	32 = 3 ways 52 = 5 ways
LEVER COLOR	1 = Red 2 = Black 3 = Green

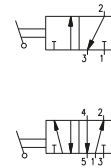

AIR DISTRIBUTION

3 ways



Weight 510 g

224.32.9/●

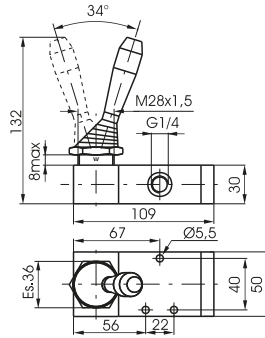

5 ways



Weight 595 g

224.52.9/●

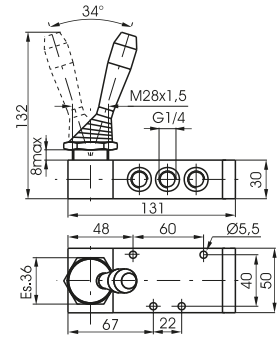

**Pedal aluminium - Spring**

Coding: 224.●.10.1

**Operational characteristics**

Fluid	Filtered air. No lubrication needed, if applied it shall be continuous
Max working pressure (bar)	10
Temperature °C	-5 ÷ +70
Flow rate at 6 bar with Δp=1 (NI/min)	1360
Orifice size (mm)	8
Working ports size	G1/4"

TYPE	32 = 3 ways 52 = 5 ways
------	----------------------------

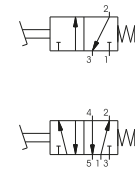

3 ways



Weight 1070 g

224.32.10.1

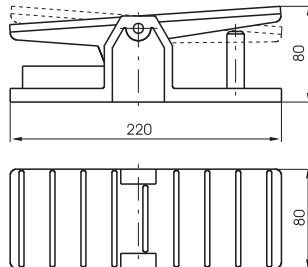

5 ways



Weight 1155 g

224.52.10.1

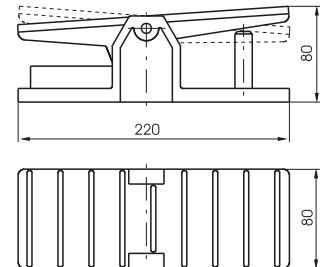

**Pedal aluminium 2 positions**

Coding: 224.●.10

**Operational characteristics**

Fluid	Filtered air. No lubrication needed, if applied it shall be continuous
Max working pressure (bar)	10
Temperature °C	-5 ÷ +70
Flow rate at 6 bar with Δp=1 (NI/min)	1360
Orifice size (mm)	8
Working ports size	G1/4"

TYPE	32 = 3 ways 52 = 5 ways
------	----------------------------

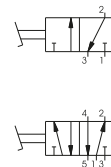

3 ways



Weight 1060 g

224.32.10

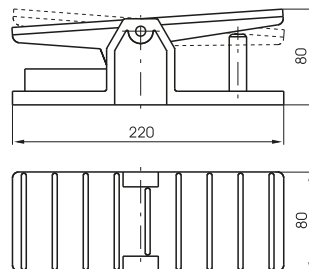

5 ways



Weight 1145 g

224.52.10

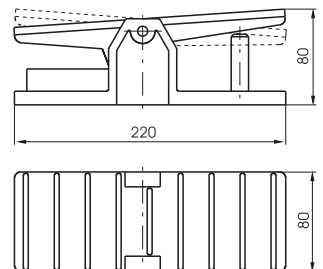

**Lateral Lever spring - 3 positions**

Coding: 224.53.F.9.1/C

Operational characteristics	
Fluid	Filtered air. No lubrication needed, if applied it shall be continuous
Max working pressure (bar)	10
Temperature °C	-5 ÷ +70
Flow rate at 6 bar with Δp=1 (NI/min)	1280
Orifice size (mm)	8
Working ports size	G1/4"

F	FUNCTION
	31 = Closed centres 32 = Open centres
C	LEVER COLOR
	1 = Red 2 = Black 3 = Green



Weight 745 g

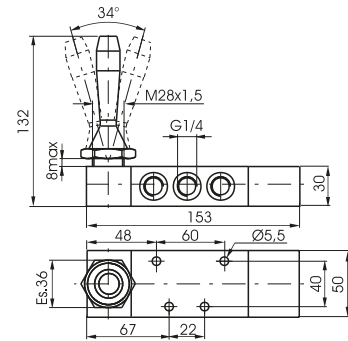
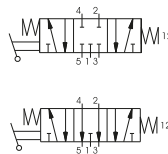

**Lever lateral 3 positions detent**

Coding: 224.53.F.9/C

Operational characteristics	
Fluid	Filtered air. No lubrication needed, if applied it shall be continuous
Max working pressure (bar)	10
Temperature °C	-5 ÷ +70
Flow rate at 6 bar with Δp=1 (NI/min)	1280
Orifice size (mm)	8
Working ports size	G1/4"

F	FUNCTION
	31 = Closed centres 32 = Open centres
C	LEVER COLOR
	1 = Red 2 = Black 3 = Green



Weight 605 g

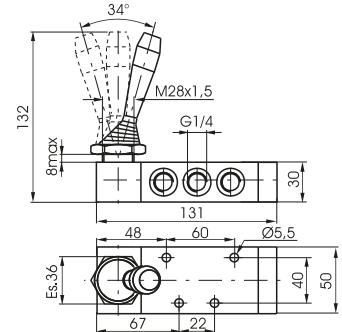
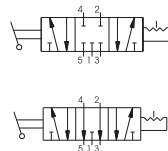

**Lever lateral with locking device - 2 positions**

Coding: 224.52.9.2

Operational characteristics	
Fluid	Filtered air. No lubrication needed, if applied it shall be continuous
Max working pressure (bar)	10
Temperature °C	-5 ÷ +70
Flow rate at 6 bar with Δp=1 (NI/min)	1020
Orifice size (mm)	8
Working ports size	G1/4"



Weight 825 g

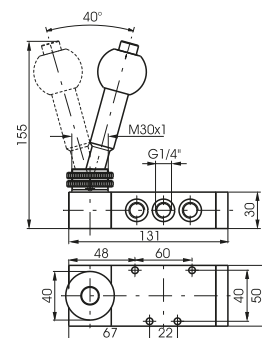

1  
AIR DISTRIBUTION

**Lever lateral with locking device - Spring 3 positions**

Coding: 224.53.F.9.2

**Operational characteristics**

Fluid	Filtered air. No lubrication needed, if applied it shall be continuous
Max working pressure (bar)	10
Temperature °C	-5 ÷ +70
Flow rate at 6 bar with Δp=1 (NI/min)	1020
Orifice size (mm)	8
Working ports size	G1/4"

FUNCTION	
F	31 = Closed centres
	32 = Open centres



Weight 965 g

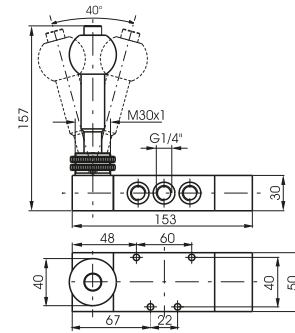
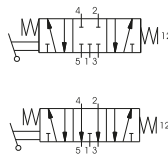

**Pedal - Spring 3 positions**

Coding: 224.53.F.10.1

**Operational characteristics**

Fluid	Filtered air. No lubrication needed, if applied it shall be continuous
Max working pressure (bar)	10
Temperature °C	-5 ÷ +70
Flow rate at 6 bar with Δp=1 (NI/min)	1280
Orifice size (mm)	8
Working ports size	G1/4"

FUNCTION	
F	31 = Closed centres
	32 = Open centres



Weight 1285 g

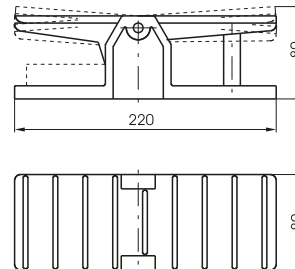
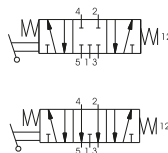

**Pedal 3 positions**

Coding: 224.53.F.10

**Operational characteristics**

Fluid	Filtered air. No lubrication needed, if applied it shall be continuous
Max working pressure (bar)	10
Temperature °C	-5 ÷ +70
Flow rate at 6 bar with Δp=1 (NI/min)	1280
Orifice size (mm)	8
Working ports size	G1/4"

FUNCTION	
F	31 = Closed centres
	32 = Open centres



Weight 1145 g

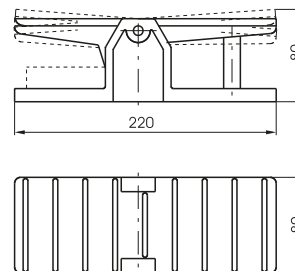
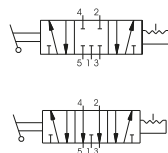

**Pneumatic - Spring**

Coding: 224.11.1

Operational characteristics	
Fluid	Filtered air. No lubrication needed, if applied it shall be continuous
Max working pressure (bar)	10
Temperature °C	-5 ÷ +70
Flow rate at 6 bar with $\Delta p=1$ (NI/min)	1360
Orifice size (mm)	8
Working ports size	G1/4"
Pilot ports size	G1/8"

TYPE	
32	= 3 ways
52	= 5 ways

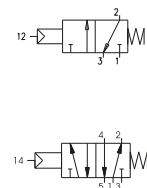

Weight 370 g  
Minimum piloting pressure 2,5 bar

224.32.11.1

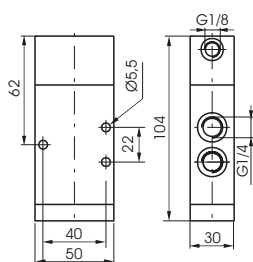

5 ways



Weight 450 g  
Minimum piloting pressure 2,5 bar

224.52.11.1

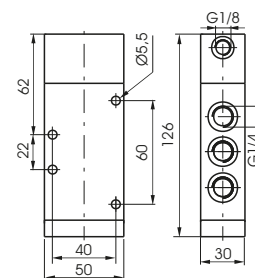

**Pneumatic - Differential external**

Coding: 224.11.12

Operational characteristics	
Fluid	Filtered air. No lubrication needed, if applied it shall be continuous
Max working pressure (bar)	11
Temperature °C	-5 ÷ +70
Flow rate at 6 bar with $\Delta p=1$ (NI/min)	1360
Orifice size (mm)	8
Working ports size	G1/4"
Pilot ports size	G1/8"

TYPE	
32	= 3 ways
52	= 5 ways

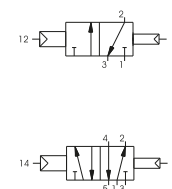

3 ways



Weight 480 g  
Minimum piloting pressure 2,5 bar

224.32.11.12

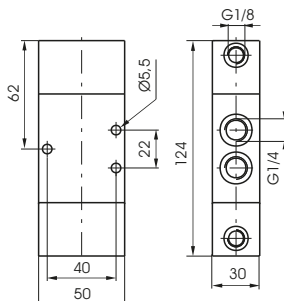

5 ways



Weight 550 g  
Minimum piloting pressure 2,5 bar

224.52.11.12

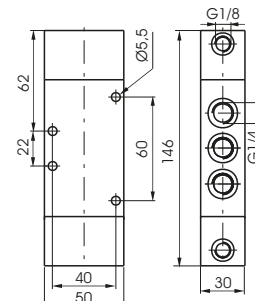

**Pneumatic - Pneumatic**

Coding: 224.11.11

Operational characteristics	
Fluid	Filtered air. No lubrication needed, if applied it shall be continuous
Max working pressure (bar)	12
Temperature °C	-5 ÷ +70
Flow rate at 6 bar with $\Delta p=1$ (NI/min)	1360
Orifice size (mm)	8
Working ports size	G1/4"
Pilot ports size	G1/8"

TYPE	
32	= 3 ways
52	= 5 ways

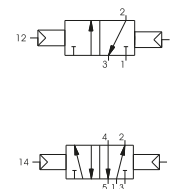

3 ways



Weight 470 g  
Minimum piloting pressure 2 bar

224.32.11.11

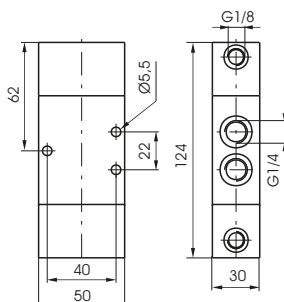

5 ways



Weight 540 g  
Minimum piloting pressure 2 bar

224.52.11.11

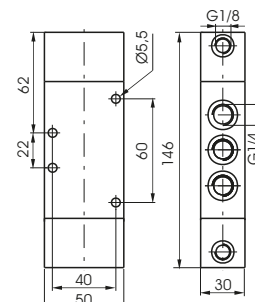



Pneumatic - Pneumatic 5 ways 3 connections

Coding: 224.53.F.11.11

Operational characteristics

Fluid	Filtered air. No lubrication needed, if applied it shall be continuous
Max working pressure (bar)	13
Temperature °C	-5 ÷ +70
Flow rate at 6 bar with $\Delta p=1$ (NI/min)	1280
Orifice size (mm)	8
Working ports size	G1/4"
Pilot ports size	G1/8"

FUNCTION	
F	31 = Closed centres
	32 = Open centres
	33 = Pressured centres

1  
AIR DISTRIBUTION

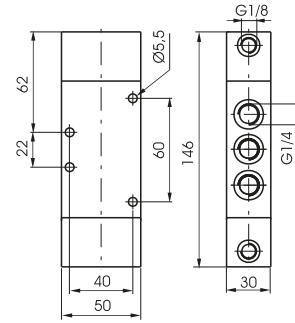
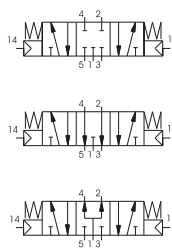

Weight 550 g  
Minimum piloting pressure 3 bar

**Pedal protected 2 positions**

Coding: 214. **T**.10/1

Operational characteristics	
Fluid	Filtered air. No lubrication needed, if applied it shall be continuous
Max working pressure (bar)	10
Temperature °C	-5 ÷ +70
Flow rate at 6 bar with Δp=1 (NI/min)	1360
Orifice size (mm)	8
Working ports size	G1/4"

<b>T</b>	TYPE
	32 = 3 ways
	52 = 5 ways

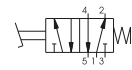
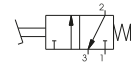

3 ways

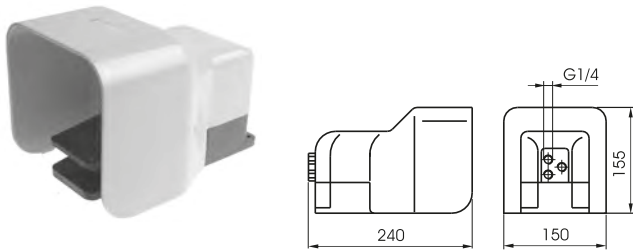

Weight 1730 g

214.32.10. **V**

5 ways

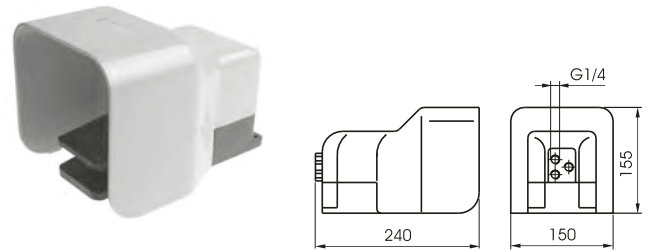

Weight 1730 g

214.52.10. **V**

**Pedal protected - Spring**

Coding: 214. **T**.10. **V**

Operational characteristics	
Fluid	Filtered air. No lubrication needed, if applied it shall be continuous
Max working pressure (bar)	10
Temperature °C	-5 ÷ +70
Flow rate at 6 bar with Δp=1 (NI/min)	1360
Orifice size (mm)	8
Working ports size	G1/4"

<b>T</b>	TYPE
	32 = 3 ways
	52 = 5 ways
<b>V</b>	VERSION
	1/1 = Standard version
	2/1 = without safety device

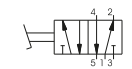
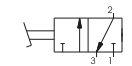

3 ways

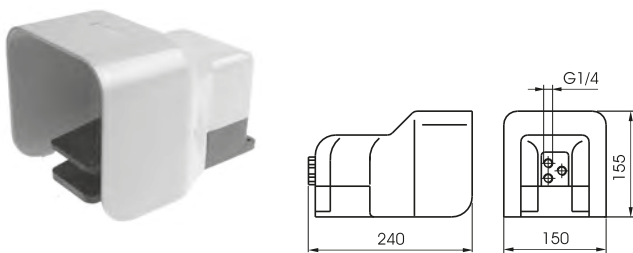

Weight 1730 g

214.32.10/1

5 ways

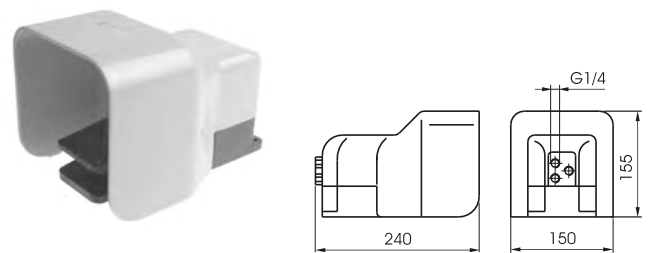

Weight 1730 g

214.52.10/1

1  
AIR DISTRIBUTION

**Lever lateral - Spring**

Coding: 212. **T**.9.1

**Operational characteristics**

Fluid	Filtered air. No lubrication needed, if applied it shall be continuous
Max working pressure (bar)	10
Temperature °C	-5 ÷ +70
Flow rate at 6 bar with Δp=1 (NI/min)	3500
Orifice size (mm)	15
Working ports size	G1/2"

TYPE
<b>T</b> 32 = 3 ways
52 = 5 ways

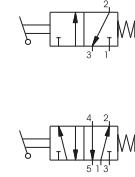

3 ways



Weight 1480 g

212.32.9.1

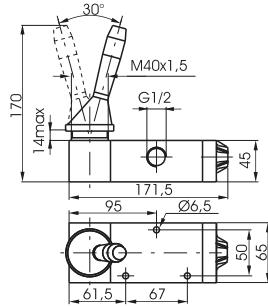

5 ways



Weight 1765 g

212.52.9.1

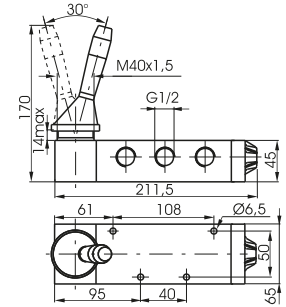

**Lever lateral 2 positions**

Coding: 212. **T**.9

**Operational characteristics**

Fluid	Filtered air. No lubrication needed, if applied it shall be continuous
Max working pressure (bar)	10
Temperature °C	-5 ÷ +70
Flow rate at 6 bar with Δp=1 (NI/min)	3500
Orifice size (mm)	15
Working ports size	G1/2"

TYPE
<b>T</b> 32 = 3 ways
52 = 5 ways

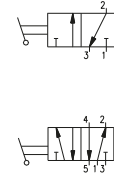

3 ways



Weight 1460 g

212.32.9

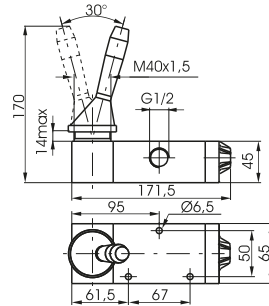

5 ways



Weight 1745 g

212.52.9

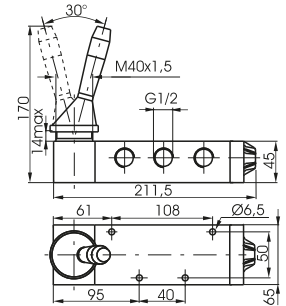

**Lever lateral spring centre 3 positions**

Coding: 212.53. **F**.9.1

**Operational characteristics**

Fluid	Filtered air. No lubrication needed, if applied it shall be continuous
Max working pressure (bar)	10
Temperature °C	-5 ÷ +70
Flow rate at 6 bar with Δp=1 (NI/min)	3000
Orifice size (mm)	15
Working ports size	G1/2"

FUNCTION
<b>F</b> 31 = Closed centres
32 = Open centres



Weight 2100 g

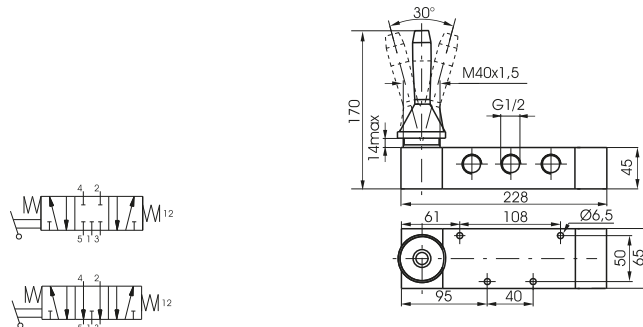



**Lever lateral 3 positions detent**

Coding: 212.53.ⓕ.9

Operational characteristics	
Fluid	Filtered air. No lubrication needed, if applied it shall be continuous
Max working pressure (bar)	10
Temperature °C	-5 ÷ +70
Flow rate at 6 bar with Δp=1 (Nl/min)	3000
Orifice size (mm)	15
Working ports size	G1/2"

FUNCTION	
ⓕ	31 = Closed centres
	32 = Open centres



Weight 1765 g

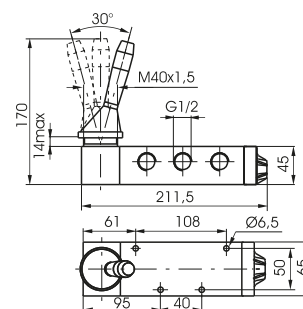
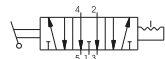
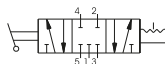



**Pneumatic - Spring**

Coding: 212.11.1

**Operational characteristics**

Fluid	Filtered air. No lubrication needed, if applied it shall be continuous
Max working pressure (bar)	10
Temperature °C	-5 ÷ +70
Flow rate at 6 bar with Δp=1 (NI/min)	3500
Orifice size (mm)	15
Working ports size	G1/2"
Pilot ports size	G1/8"

TYPE	
32 = 3 ways	
52 = 5 ways	

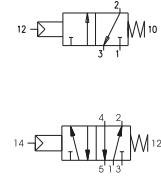

3 ways

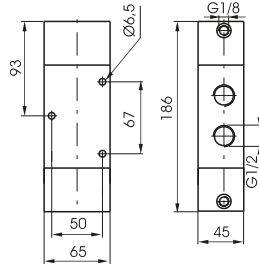

Weight 1110 g  
Minimum piloting pressure 2,5 bar

212.32.11.1

5 ways

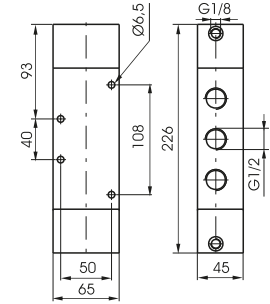

Weight 1390 g  
Minimum piloting pressure 2,5 bar

212.52.11.1

**Pneumatic - Differential external**

Coding: 212.11.12

**Operational characteristics**

Fluid	Filtered air. No lubrication needed, if applied it shall be continuous
Max working pressure (bar)	10
Temperature °C	-5 ÷ +70
Flow rate at 6 bar with Δp=1 (NI/min)	3500
Orifice size (mm)	15
Working ports size	G1/2"
Pilot ports size	G1/8"

TYPE	
32 = 3 ways	
52 = 5 ways	

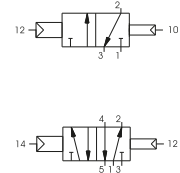

3 ways

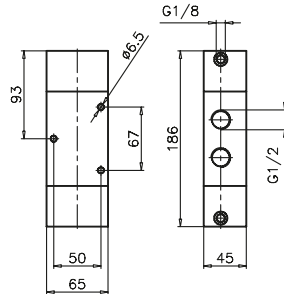

Weight 1380 g  
Minimum piloting pressure 2,5 bar

212.32.11.12

5 ways

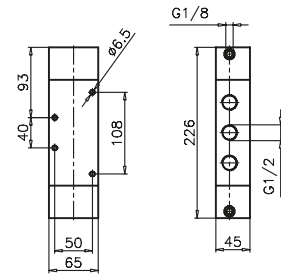

Weight 1660 g  
Minimum piloting pressure 2,5 bar

212.52.11.12

**Pneumatic - Pneumatic**

Coding: 212.11.11

**Operational characteristics**

Fluid	Filtered air. No lubrication needed, if applied it shall be continuous
Max working pressure (bar)	10
Temperature °C	-5 ÷ +70
Flow rate at 6 bar with Δp=1 (NI/min)	3500
Orifice size (mm)	15
Working ports size	G1/2"
Pilot ports size	G1/8"

TYPE	
32 = 3 ways	
52 = 5 ways	

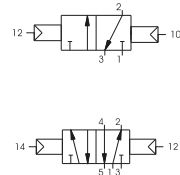

3 ways

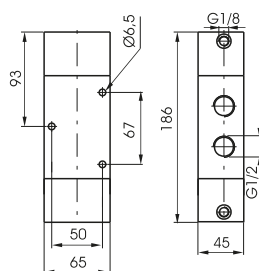

Weight 1350 g  
Minimum piloting pressure 2 bar

212.32.11.11

5 ways

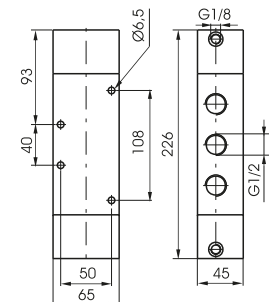

Weight 1630 g  
Minimum piloting pressure 2 bar

212.52.11.11

1 AIR DISTRIBUTION

**Pneumatic - Pneumatic 5 ways 3 connections**

Coding: 212.53.ⓕ.11.11

Operational characteristics	
Fluid	Filtered air. No lubrication needed, if applied it shall be continuous
Max working pressure (bar)	10
Temperature °C	-5 ÷ +70
Flow rate at 6 bar with Δp=1 (NI/min)	3000
Orifice size (mm)	15
Working ports size	G1/2"
Pilot ports size	G1/8"

FUNCTION	
ⓕ	31 = Closed centres
	32 = Open centres
	33 = Pressured centres

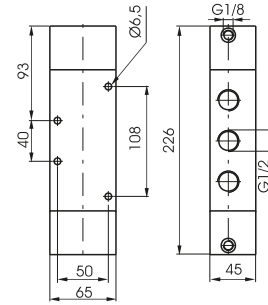
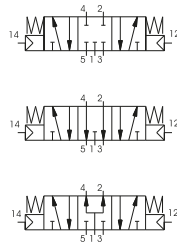

Weight 1650 g  
Minimum piloting pressure 3 bar

1  
AIR DISTRIBUTION

### Pneumatic - Differential external

Coding: 212/2.11.1

#### Operational characteristics

Fluid	Filtered air. No lubrication needed, if applied it shall be continuous
Max working pressure (bar)	10
Temperature °C	-5 ÷ +70
Flow rate at 6 bar with Δp=1 (NI/min)	3600
Orifice size (mm)	15
Working ports size	G1/2"
Pilot ports size	G1/8"

TYPE	
32 = 3 ways	
52 = 5 ways	

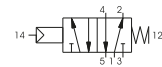
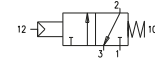

3 ways

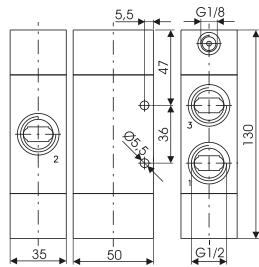

Weight 524 g  
Minimum piloting pressure 2,5 bar

212/2.32.11.1

5 ways

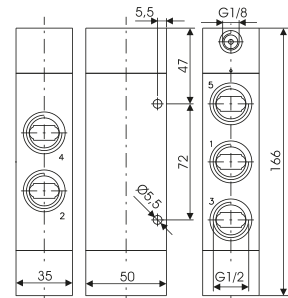

Weight 644 g  
Minimum piloting pressure 2,5 bar

212/2.52.11.1

### Pneumatic - Differential self aligned

Coding: 212/2.11.12

#### Operational characteristics

Fluid	Filtered air. No lubrication needed, if applied it shall be continuous
Max working pressure (bar)	10
Temperature °C	-5 ÷ +70
Flow rate at 6 bar with Δp=1 (NI/min)	3600
Orifice size (mm)	15
Working ports size	G1/2"
Pilot ports size	G1/8"

TYPE	
32 = 3 ways	
52 = 5 ways	

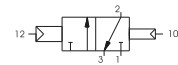

3 ways

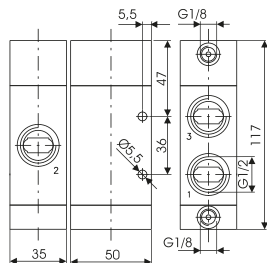

Weight 464 g  
Minimum piloting pressure 2,5 bar

212/2.32.11.12

5 ways

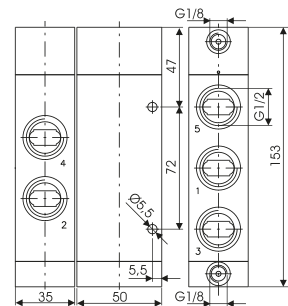

Weight 586 g  
Minimum piloting pressure 2,5 bar

212/2.52.11.12

### Pneumatic - Pneumatic

Coding: 212/2.11.12.F

#### Operational characteristics

Fluid	Filtered air. No lubrication needed, if applied it shall be continuous
Max working pressure (bar)	10
Temperature °C	-5 ÷ +70
Flow rate at 6 bar with Δp=1 (NI/min)	3600
Orifice size (mm)	15
Working ports size	G1/2"
Pilot ports size	G1/8"

TYPE	
32 = 3 ways	
52 = 5 ways	
FUNCTION	
1.C = Normally closed	
1.A = Normally open	
1 = Self-feeding	

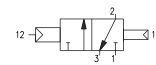
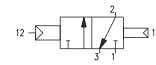

3 ways

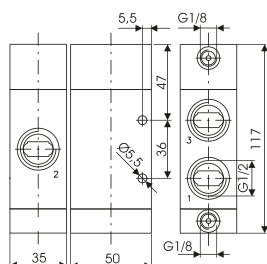

Weight 466 g  
Minimum piloting pressure 2,5 bar

212/2.32.11.12/F

5 ways

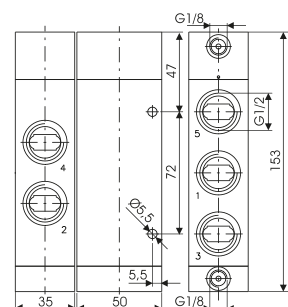

Weight 588 g  
Minimum piloting pressure 2,5 bar

212/2.52.11.12/F

AIR DISTRIBUTION 1

**Amplified pneumatic - Spring**

Coding: 212/2.11.11

Operational characteristics	
Fluid	Filtered air. No lubrication needed, if applied it shall be continuous
Max working pressure (bar)	10
Temperature °C	-5 ÷ +70
Flow rate at 6 bar with Δp=1 (Nl/min)	3600
Orifice size (mm)	15
Working ports size	G1/2"
Pilot ports size	G1/8"

TYPE	
32	= 3 ways
52	= 5 ways

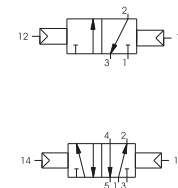

Weight 518 g  
Minimum piloting pressure 2,5 bar

212/2.32.11.11

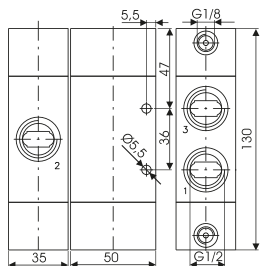

5 ways



Weight 640 g  
Minimum piloting pressure 2,5 bar

212/2.52.11.11

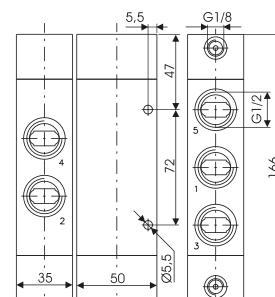

1

AIR DISTRIBUTION

**Pneumatic - Pneumatic 5 ways 3 connections**

Coding: 212/2.53.11.11

Operational characteristics	
Fluid	Filtered air. No lubrication needed, if applied it shall be continuous
Max working pressure (bar)	10
Temperature °C	-5 ÷ +70
Flow rate at 6 bar with Δp=1 (Nl/min)	3300
Orifice size (mm)	15
Working ports size	G1/2"
Pilot ports size	G1/8"

FUNCTION	
31	= Closed centres
32	= Open centres
33	= Pressured centres



Weight 684 g  
Minimum piloting pressure 3 bar

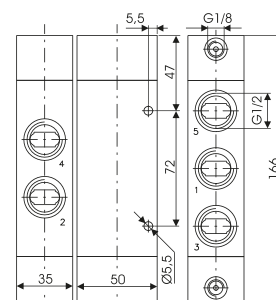
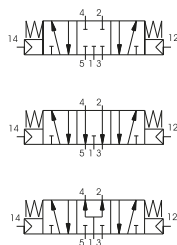

**Lever lateral - Spring**

Coding: 211.1.9.1

**Operational characteristics**

Fluid	Filtered air. No lubrication needed, if applied it shall be continuous
Max working pressure (bar)	10
Temperature °C	-5 ÷ +70
Flow rate at 6 bar with Δp=1 (NI/min)	6500
Orifice size (mm)	20
Working ports size	G1"

TYPE
1 32 = 3 ways
52 = 5 ways

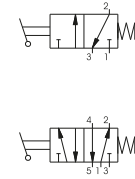

3 ways



Weight 4300 g

211.32.9.1

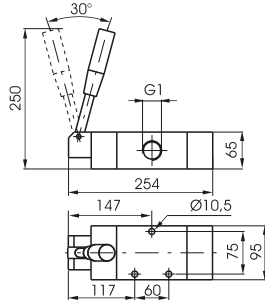

5 ways



Weight 4900 g

211.52.9.1

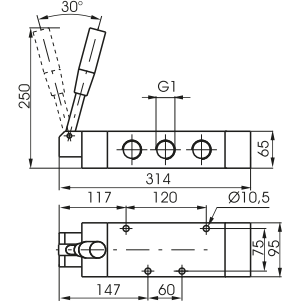

**Lever lateral 2 positions**

Coding: 211.1.9

**Operational characteristics**

Fluid	Filtered air. No lubrication needed, if applied it shall be continuous
Max working pressure (bar)	10
Temperature °C	-5 ÷ +70
Flow rate at 6 bar with Δp=1 (NI/min)	6500
Orifice size (mm)	20
Working ports size	G1"

TYPE
1 32 = 3 ways
52 = 5 ways

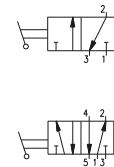

3 ways



Weight 4300 g

211.32.9

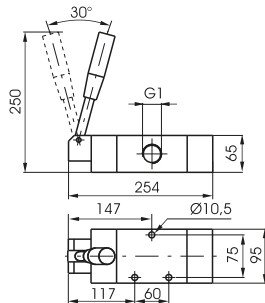

5 ways



Weight 4900 g

211.52.9

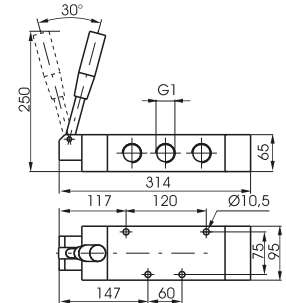

**Lever lateral spring centre 3 positions**

Coding: 211.53.1.9.1

**Operational characteristics**

Fluid	Filtered air. No lubrication needed, if applied it shall be continuous
Max working pressure (bar)	10
Temperature °C	-5 ÷ +70
Flow rate at 6 bar with Δp=1 (NI/min)	6500
Orifice size (mm)	20
Working ports size	G1"

FUNCTION
F 31 = Closed centres
32 = Open centres



Weight 5000 g

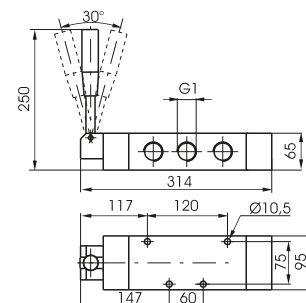
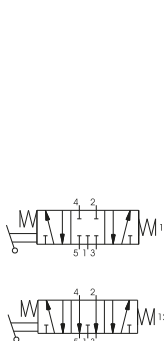

**Lever lateral 3 positions detent**

Coding: 211.53.F.9

Operational characteristics	
Fluid	Filtered air. No lubrication needed, if applied it shall be continuous
Max working pressure (bar)	10
Temperature °C	-5 ÷ +70
Flow rate at 6 bar with $\Delta p=1$ (l/min)	6500
Orifice size (mm)	20
Working ports size	G1"

FUNCTION	
F	31 = Closed centres
	32 = Open centres

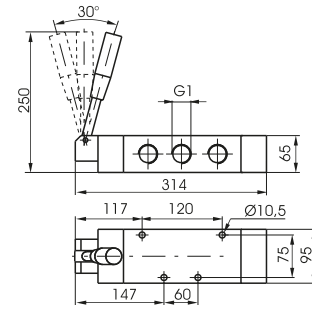
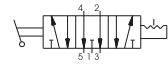
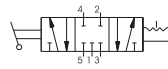

Weight 5000 g

1  
AIR DISTRIBUTION

**Pneumatic - Spring**

Coding: 211.1.11.1

**Operational characteristics**

Fluid	Filtered air. No lubrication needed, if applied it shall be continuous
Max working pressure (bar)	10
Temperature °C	-5 ÷ +70
Flow rate at 6 bar with Δp=1 (NI/min)	6500
Orifice size (mm)	20
Working ports size	G1"
Pilot ports size	G1/8"

TYPE
32 = 3 ways
52 = 5 ways

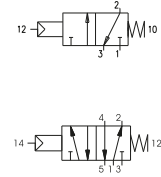

3 ways

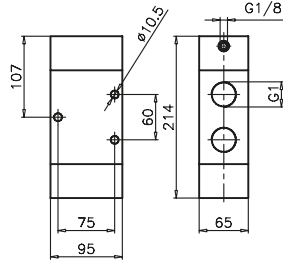

Weight 3330 g  
Minimum piloting pressure 2,5 bar

211.32.11.1

5 ways

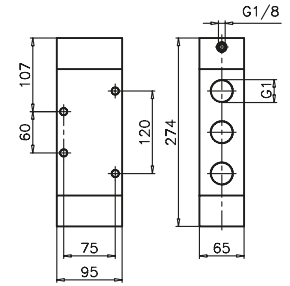

Weight 4200 g  
Minimum piloting pressure 2,5 bar

211.52.11.1

**Pneumatic - Differential external**

Coding: 211.1.11.12

**Operational characteristics**

Fluid	Filtered air. No lubrication needed, if applied it shall be continuous
Max working pressure (bar)	10
Temperature °C	-5 ÷ +70
Flow rate at 6 bar with Δp=1 (NI/min)	6500
Orifice size (mm)	20
Working ports size	G1"
Pilot ports size	G1/8"

TYPE
32 = 3 ways
52 = 5 ways

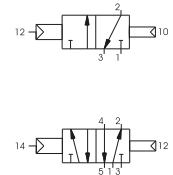

3 ways

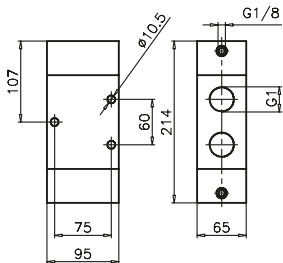

Weight 3330 g  
Minimum piloting pressure 2,5 bar

211.32.11.12

5 ways

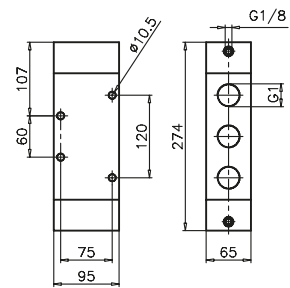

Weight 4200 g  
Minimum piloting pressure 2,5 bar

211.52.11.12

**Pneumatic - Pneumatic**

Coding: 211.1.11.11

**Operational characteristics**

Fluid	Filtered air. No lubrication needed, if applied it shall be continuous
Max working pressure (bar)	10
Temperature °C	-5 ÷ +70
Flow rate at 6 bar with Δp=1 (NI/min)	6500
Orifice size (mm)	20
Working ports size	G1"
Pilot ports size	G1/8"

TYPE
32 = 3 ways
52 = 5 ways

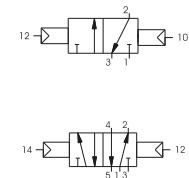

3 ways

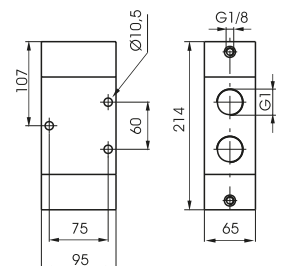

Weight 3330 g  
Minimum piloting pressure 2 bar

211.32.11.11

5 ways

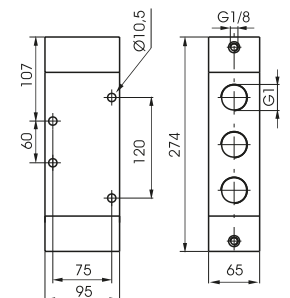

Weight 4200 g  
Minimum piloting pressure 2 bar

211.52.11.11

1 AIR DISTRIBUTION



**Pneumatic - Pneumatic 5 ways 3 connections**

Coding: 211.53.F.11.11

Operational characteristics	
Fluid	Filtered air. No lubrication needed, if applied it shall be continuous
Max working pressure (bar)	10
Temperature °C	-5 ÷ +70
Flow rate at 6 bar with Δp=1 (l/min)	6500
Orifice size (mm)	20
Working ports size	G1"
Pilot ports size	G1/8"

FUNCTION	
<b>F</b>	31 = Closed centres
	32 = Open centres
	33 = Pressured centres

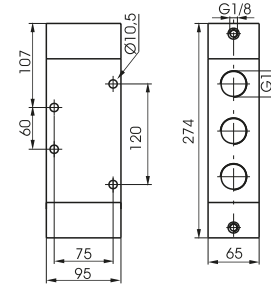
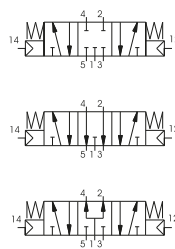

Weight 4200 g  
Minimum piloting pressure 3 bar

1  
AIR DISTRIBUTION



## Series T200

### General

The **T200** series, consist of a broad range of valves with various type of actuation. The connections for this series are from G 1/8" to G 1/4". The main components constituting the valves of the Tecno228 series are manufactured with high performance technopolymer. The use of technopolymer has resulted in a light weight product which can be offered to the market at very interesting prices. The **T228** series, is manufactured with 1/8" connections, 3 and 5 ways function, mechanical or pneumatically operated, monostable spring or pneumatic return, bistable and in 5 ways 3 positions version with closed, open and pressured centres. This series is completely interchangeable with the standard 228 series (with aluminium body). The **T224** valves and solenoid valves series, are manufactured with 1/4" connections. Depending on version and actuation (manual, pneumatic, or electrical), and self aligning (pneu - elect, spring) 3/2, 5/2 and 5/3 ways function, (monostable), (bistable). The gang mounted solenoid valves are available with the traditional manifold obtained from bored square bar of series 600 and with the extruded aluminium base allowing a unic inlet port conveying the exhausts. The base is also prearranged to be fixed on DIN 46277/3 guide.

### Maximum fitting torque

Thread	Maximum torque (Nm)
G 1/8"	4
G1/4"	9

### Construction characteristics

	G 1/8" (T228) and G 1/4" (T224)
Body	Technopolymer
Operators	Technopolymer
Seals	NBR
Spacer	Technopolymer
Spools	Technopolymer Stainless steel only for the versions Push button-Spring and Lever lateral
Springs	Spring steel
Pistons	Technopolymer

### Use and maintenance

This valves have an average life of 15 million cycles depending on the application and air quality. Filtered and lubricated air using specified lubricants will reduce the wear of the seals and ensures long and trouble free operation. Please ensure that the valve is being used according with the manufacturers specification, such as air pressure and temperature. The exhaust port of the distributor has to be protected in a dusty and dirty environment. Repair kits including the spool complete with seals are available for overhauling the valves. However, although this is a simple operation it should be carried out by a competent person.

**ATTENTION:** use hydraulic oil class H for lubrication such as MAGNA GC 32 (Castrol).

### Tappet - Spring

Coding: T228.1.0.1

Operational characteristics	
Fluid	Filtered air. No lubrication needed, if applied it shall be continuous
Max working pressure (bar)	10
Temperature °C	-5 ÷ +50
Flow rate at 6 bar with Δp=1 (NI/min)	620
Orifice size (mm)	6
Working ports size	G1/8"

TYPE	
32 = 3 ways	
52 = 5 ways	

Operating force 33 N

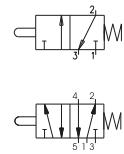

3 ways



Weight 60 g

T228.32.0.1

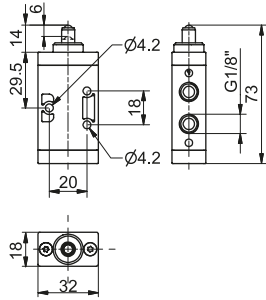

5 ways



Weight 72 g

T228.52.0.1

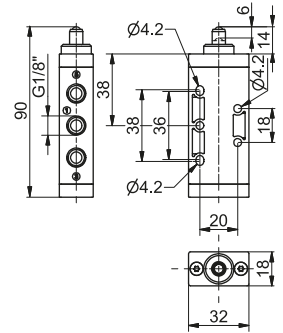

### Tappet panel - Spring

Coding: T228.1.1.1

Operational characteristics	
Fluid	Filtered air. No lubrication needed, if applied it shall be continuous
Max working pressure (bar)	10
Temperature °C	-5 ÷ +50
Flow rate at 6 bar with Δp=1 (NI/min)	620
Orifice size (mm)	6
Working ports size	G1/8"

TYPE	
32 = 3 ways	
52 = 5 ways	

Operating force 33 N

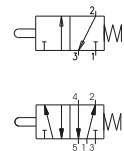

3 ways



Weight 77 g

T228.32.1.1

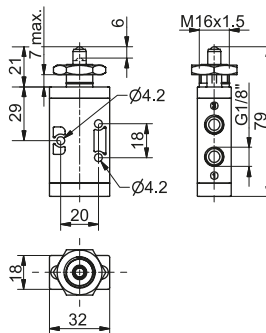

5 ways



Weight 90 g

T228.52.1.1

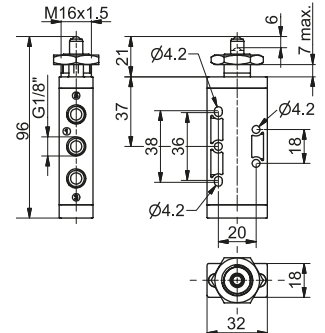

### Lever roller

Coding: T228.1.2.V

Operational characteristics	
Fluid	Filtered air. No lubrication needed, if applied it shall be continuous
Max working pressure (bar)	10
Temperature °C	-5 ÷ +50
Flow rate at 6 bar with Δp=1 (NI/min)	620
Orifice size (mm)	6
Working ports size	G1/8"

TYPE	
32 = 3 ways	
52 = 5 ways	
VERSION	
1 = Plastic roller	
1/1 = ball bearing	
1/2 = Metal roller	

Operating force 15 N

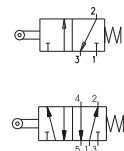

3 ways



Weight 90 g

T228.32.2.V

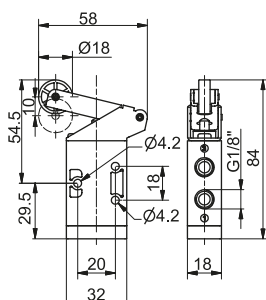

5 ways



Weight 102 g

T228.52.2.V

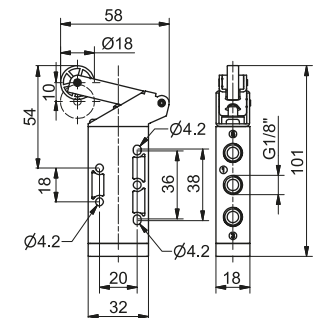

### Lever roller ball bearing - Spring

**Coding:** T228.1.2.1/1

**Operational characteristics**

Fluid	Filtered air. No lubrication needed, if applied it shall be continuous
Max working pressure (bar)	10
Temperature °C	-5 ÷ +50
Flow rate at 6 bar with Δp=1 (NI/min)	620
Orifice size (mm)	6
Working ports size	G1/8"

TYPE	
1	32 = 3 ways
	52 = 5 ways

Operating force 15 N

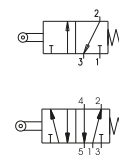
**3 ways**

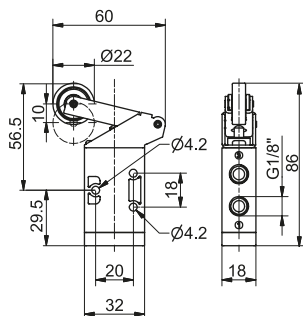

Weight 105 g

T228.32.2.1/1

**5 ways**

Weight 117 g

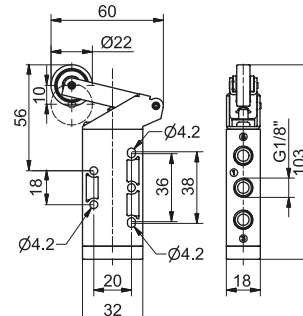
T228.52.2.1/1



### Lever button - Spring

**Coding:** T228.1.2.6/C

**Operational characteristics**

Fluid	Filtered air. No lubrication needed, if applied it shall be continuous
Max working pressure (bar)	10
Temperature °C	-5 ÷ +50
Flow rate at 6 bar with Δp=1 (NI/min)	620
Orifice size (mm)	6
Working ports size	G1/8"

TYPE	
1	32 = 3 ways
	52 = 5 ways
LEVER COLOR	
1	Red
2	Black
3	Green

Operating force 15 N

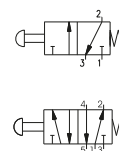
**3 ways**

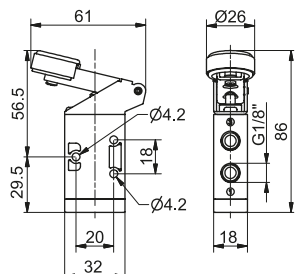

Weight 95 g

T228.32.2.6/C

**5 ways**

Weight 87 g

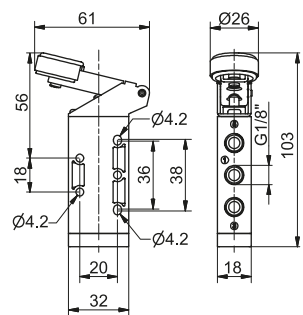
T228.52.2.6/C



### Lever roller unidirectional - Spring

**Coding:** T228.1.3.V

**Operational characteristics**

Fluid	Filtered air. No lubrication needed, if applied it shall be continuous
Max working pressure (bar)	10
Temperature °C	-5 ÷ +50
Flow rate at 6 bar with Δp=1 (NI/min)	620
Orifice size (mm)	6
Working ports size	G1/8"

TYPE	
1	32 = 3 ways
	52 = 5 ways
VERSION	
1	Plastic roller
1/2	Metal roller

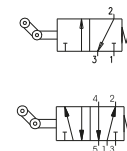
**3 ways**

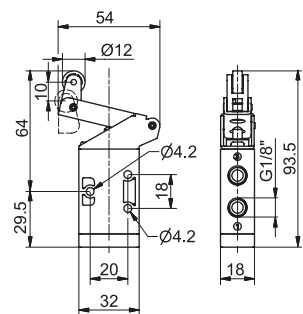

Weight 85 g

T228.32.3.V

**5 ways**

Weight 97 g

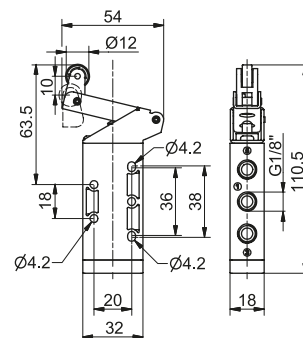
T228.52.3.V



**Lever panel Ø30 - 2 positions**

Coding: T228.1.5/©

Operational characteristics	
Fluid	Filtered air. No lubrication needed, if applied it shall be continuous
Max working pressure (bar)	10
Temperature °C	-5 ÷ +50
Flow rate at 6 bar with Δp=1 (NI/min)	620
Orifice size (mm)	6
Working ports size	G1/8"

T	TYPE
	32 = 3 ways 52 = 5 ways
C	LEVER COLOR
	1 = Red 2 = Black 3 = Green

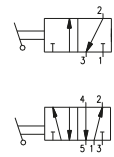

3 ways



Weight 168 g

T228.32.5/©

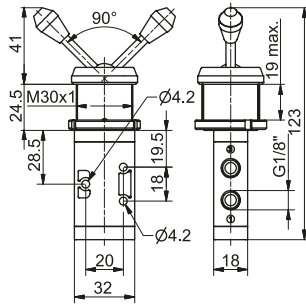

5 ways



Weight 180 g

T228.52.5/©

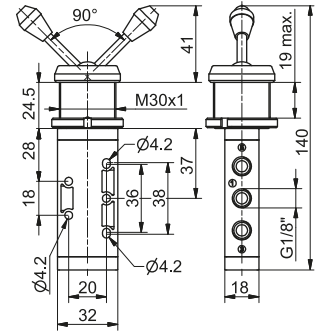

**Lever lateral 2 positions**

Coding: T228.1.55/©

Operational characteristics	
Fluid	Filtered air. No lubrication needed, if applied it shall be continuous
Max working pressure (bar)	10
Temperature °C	-5 ÷ +50
Flow rate at 6 bar with Δp=1 (NI/min)	620
Orifice size (mm)	6
Working ports size	G1/8"

T	TYPE
	32 = 3 ways 52 = 5 ways
C	LEVER COLOR
	1 = Red 2 = Black 3 = Green

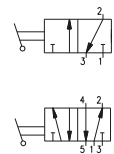

3 ways



Weight 84 g

T228.32.55/©

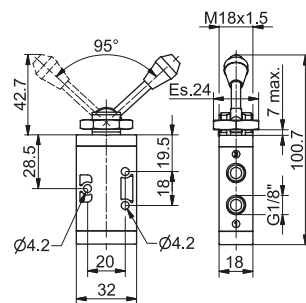

5 ways



Weight 96 g

T228.52.55/©

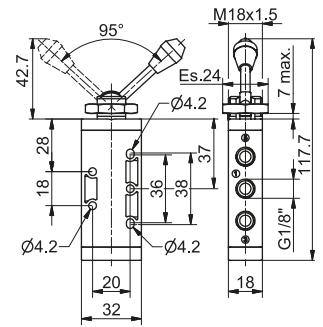

**Push button Ø 30 - spring**

Coding: T228.1.6.1/©

Operational characteristics	
Fluid	Filtered air. No lubrication needed, if applied it shall be continuous
Max working pressure (bar)	10
Temperature °C	-5 ÷ +50
Flow rate at 6 bar with Δp=1 (NI/min)	620
Orifice size (mm)	6
Working ports size	G1/8"

T	TYPE
	32 = 3 ways 52 = 5 ways
C	BUTTON COLOR
	1 = Red 2 = Black 3 = Green

Operating force 33 N

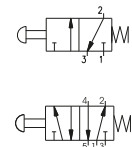

3 ways



Weight 125 g

T228.32.6.1/©

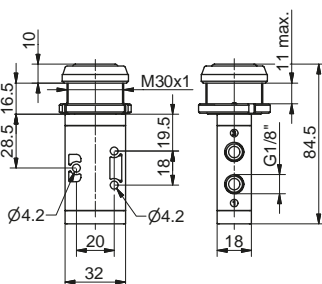

5 ways



Weight 137 g

T228.52.6.1/©

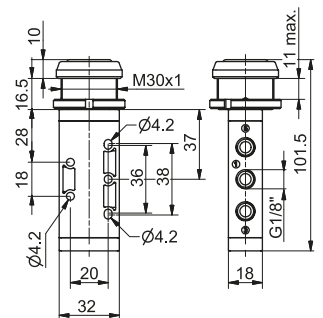



**Push button - Spring**

Coding: T228.1.6.22/C

**Operational characteristics**

Fluid	Filtered air. No lubrication needed, if applied it shall be continuous
Max working pressure (bar)	10
Temperature °C	-5 ÷ +50
Flow rate at 6 bar with Δp=1 (NI/min)	620
Orifice size (mm)	6
Working ports size	G1/8"

TYPE	32 = 3 ways 52 = 5 ways
BUTTON COLOR	1 = Red 2 = Black 3 = Green 4 = Yellow

Operating force 33 N

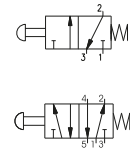

3 ways

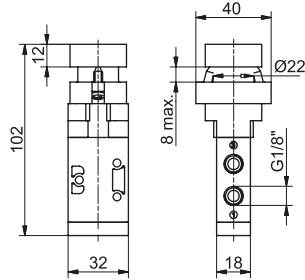

Weight 200 g

T228.32.6.22/C

5 ways

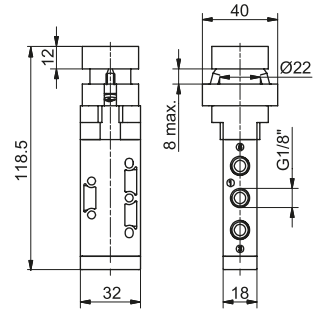

Weight 212 g

T228.52.6.22/C

**Raised push button Ø22 - Spring**

Coding: T228.1.6.23/C

**Operational characteristics**

Fluid	Filtered air. No lubrication needed, if applied it shall be continuous
Max working pressure (bar)	10
Temperature °C	-5 ÷ +50
Flow rate at 6 bar with Δp=1 (NI/min)	620
Orifice size (mm)	6
Working ports size	G1/8"

TYPE	32 = 3 ways 52 = 5 ways
BUTTON COLOR	1 = Red 2 = Black 3 = Green 4 = Yellow

Operating force 33 N

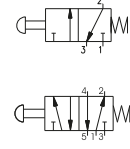

3 ways

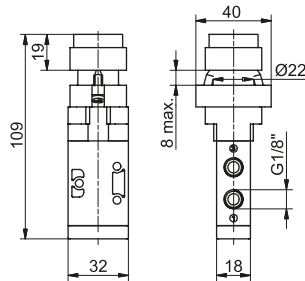

Weight 205 g

T228.32.6.23/C

5 ways

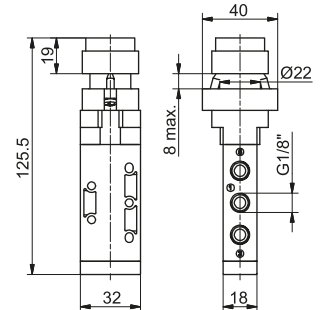

Weight 217 g

T228.52.6.23/C

**Push button Ø22 - 2 positions**

Coding: T228.1.6.25

**Operational characteristics**

Fluid	Filtered air. No lubrication needed, if applied it shall be continuous
Max working pressure (bar)	10
Temperature °C	-5 ÷ +50
Flow rate at 6 bar with Δp=1 (NI/min)	620
Orifice size (mm)	6
Working ports size	G1/8"

TYPE	32 = 3 ways 52 = 5 ways
------	----------------------------

Operating force 33 N

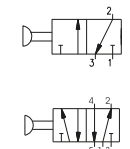

3 ways

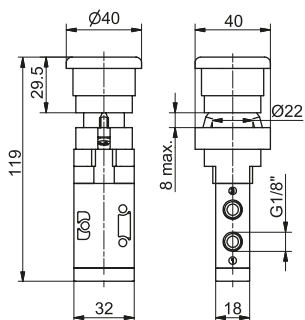

Weight 210 g

T228.32.6.25

5 ways

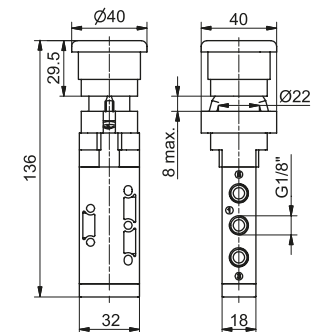

Weight 202 g

T228.52.6.25

AIR DISTRIBUTION 1

Switch 2 positions

Coding: T228.1.6.27

Operational characteristics	
Fluid	Filtered air. No lubrication needed, if applied it shall be continuous
Max working pressure (bar)	10
Temperature °C	-5 ÷ +50
Flow rate at 6 bar with Δp=1 (NI/min)	620
Orifice size (mm)	6
Working ports size	G1/8"

T	TYPE
	32 = 3 ways
	52 = 5 ways

Operating force 33 N

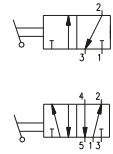

3 ways

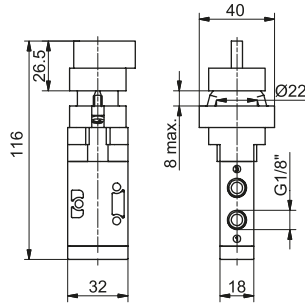

Weight 205 g

T228.32.6.27

5 ways

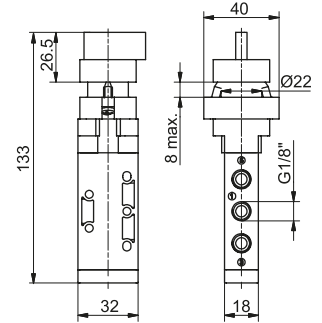

Weight 217 g

T228.52.6.27

Key switch 2 positions

Coding: T228.1.6.28

Operational characteristics	
Fluid	Filtered air. No lubrication needed, if applied it shall be continuous
Max working pressure (bar)	10
Temperature °C	-5 ÷ +50
Flow rate at 6 bar with Δp=1 (NI/min)	620
Orifice size (mm)	6
Working ports size	G1/8"

T	TYPE
	32 = 3 ways
	52 = 5 ways

Operating force 33 N

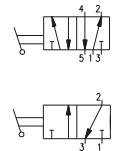

5 ways

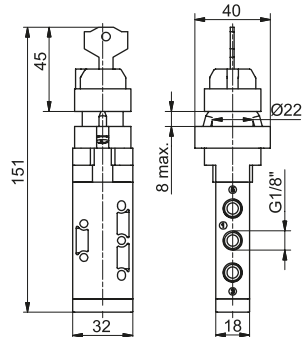

Weight 217 g

T228.52.6.28

3 ways

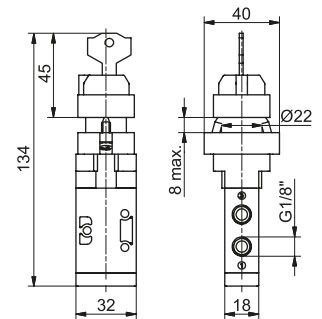

Weight 205 g

T228.32.6.28

Palm push button Ø30 2 positions

Coding: T228.1.7.1/C

Operational characteristics	
Fluid	Filtered air. No lubrication needed, if applied it shall be continuous
Max working pressure (bar)	10
Temperature °C	-5 ÷ +50
Flow rate at 6 bar with Δp=1 (NI/min)	620
Orifice size (mm)	6
Working ports size	G1/8"

T	TYPE
	32 = 3 ways
	52 = 5 ways
C	BUTTON COLOR
	1 = Red
	2 = Black
3 = Green	

Operating force 33 N

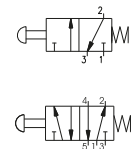

3 ways

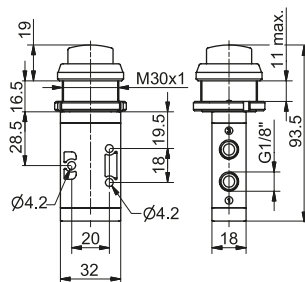

Weight 118 g

T228.32.7.1/C

5 ways

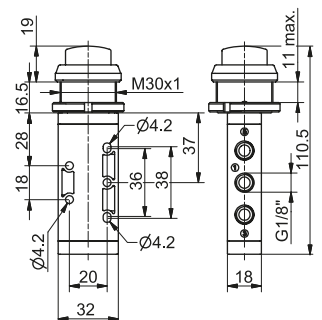

Weight 130 g

T228.52.7.1/C

**Push button - Spring**

Coding: T228.1.8.1/C

**Operational characteristics**

Fluid	Filtered air. No lubrication needed, if applied it shall be continuous
Max working pressure (bar)	10
Temperature °C	-5 ÷ +50
Flow rate at 6 bar with Δp=1 (NI/min)	620
Orifice size (mm)	6
Working ports size	G1/8"

TYPE	32 = 3 ways 52 = 5 ways
BUTTON COLOR	1 = Red 2 = Black 3 = Green

Operating force 33 N

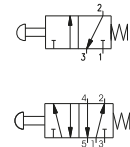

3 ways

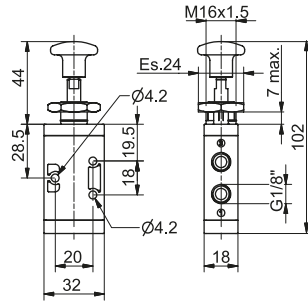

Weight 95 g

T228.32.8.1/C

5 ways

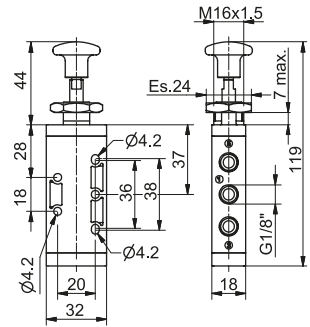

Weight 107 g

T228.52.8.1/C

**Push button 2 positions**

Coding: T228.1.8/C

**Operational characteristics**

Fluid	Filtered air. No lubrication needed, if applied it shall be continuous
Max working pressure (bar)	10
Temperature °C	-5 ÷ +50
Flow rate at 6 bar with Δp=1 (NI/min)	620
Orifice size (mm)	6
Working ports size	G1/8"

TYPE	32 = 3 ways 52 = 5 ways
BUTTON COLOR	1 = Red 2 = Black 3 = Green

Operating force 10 N

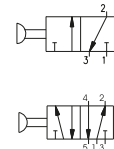

3 ways

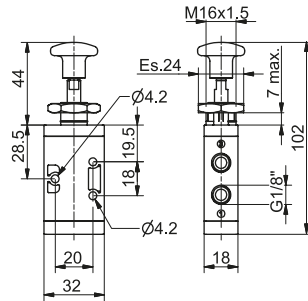

Weight 95 g

T228.32.8/C

5 ways

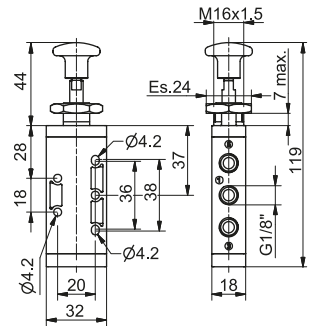

Weight 107 g

T228.52.8/C

**Lever lateral - Spring**

Coding: T228.1.9.1/C

**Operational characteristics**

Fluid	Filtered air. No lubrication needed, if applied it shall be continuous
Max working pressure (bar)	10
Temperature °C	-5 ÷ +50
Flow rate at 6 bar with Δp=1 (NI/min)	620
Orifice size (mm)	6
Working ports size	G1/8"

TYPE	32 = 3 ways 52 = 5 ways
LEVER COLOR	1 = Red 2 = Black 3 = Green

Operating force 33 N

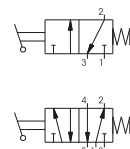

3 ways

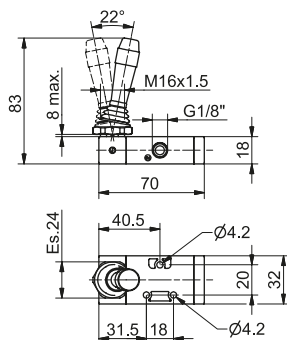

Weight 100 g

T228.32.9.1/C

5 ways

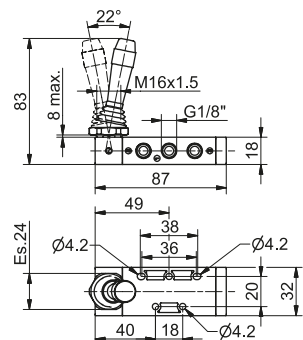

Weight 110 g

T228.52.9.1/C

AIR DISTRIBUTION 1



**Lever lateral 2 positions**

Coding: T228.1.9/C

Operational characteristics	
Fluid	Filtered air. No lubrication needed, if applied it shall be continuous
Max working pressure (bar)	10
Temperature °C	-5 ÷ +50
Flow rate at 6 bar with Δp=1 (NI/min)	620
Orifice size (mm)	6
Working ports size	G1/8"

T	TYPE
	32 = 3 ways 52 = 5 ways
C	LEVER COLOR
	1 = Red 2 = Black 3 = Green

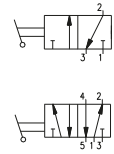

3 ways



Weight 100 g

T228.32.9/C

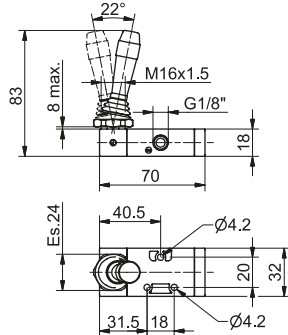

5 ways



Weight 110 g

T228.52.9/C

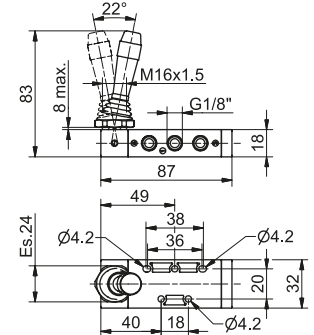

**Lever lateral - Spring 3 positions**

Coding: T228.53.F.9.1.C

Operational characteristics	
Fluid	Filtered air. No lubrication needed, if applied it shall be continuous
Max working pressure (bar)	10
Temperature °C	-5 ÷ +50
Flow rate at 6 bar with Δp=1 (NI/min)	410
Orifice size (mm)	6
Working ports size	G1/8"

F	FUNCTION
	31 = Closed centres 32 = Open centres
C	LEVER COLOR
	1 = Red 2 = Black 3 = Green



Weight 140 g

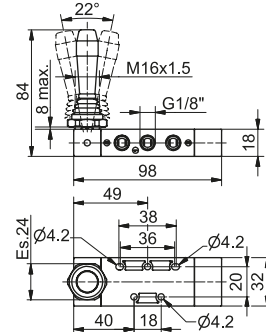
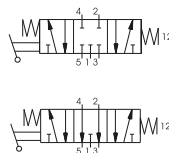

**Lever lateral - Spring 3 positions detent**

Coding: T228.53.F.9/C

Operational characteristics	
Fluid	Filtered air. No lubrication needed, if applied it shall be continuous
Max working pressure (bar)	10
Temperature °C	-5 ÷ +70
Flow rate at 6 bar with Δp=1 (NI/min)	410
Orifice size (mm)	6
Working ports size	G1/8"

F	FUNCTION
	31 = Closed centres 32 = Open centres
C	LEVER COLOR
	1 = Red 2 = Black 3 = Green



Weight 110 g

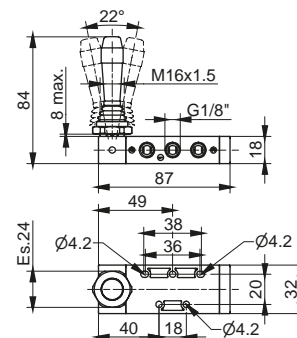
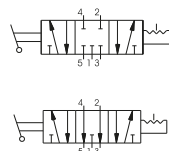

**Pneumatic - Spring**

Coding: T228.1.11.1

**Operational characteristics**

Fluid	Filtered air. No lubrication needed, if applied it shall be continuous
Max working pressure (bar)	10
Temperature °C	-5 ÷ +50
Flow rate at 6 bar with Δp=1 (NI/min)	620
Orifice size (mm)	6
Working ports size	G1/8"
Pilot ports size	G1/8"

TYPE	
① 32 = 3 ways	
52 = 5 ways	

Minimum piloting pressure 2,5 bar

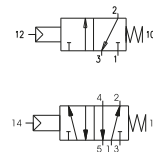

3 ways

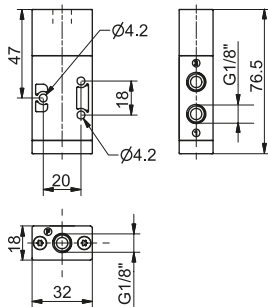

Weight 65 g

T228.32.11.1

5 ways

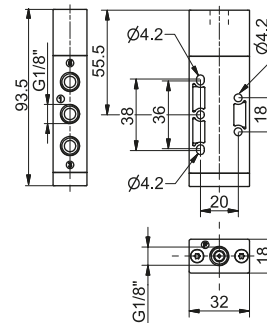

Weight 78 g

T228.52.11.1

**Pneumatic - Differential external**

Coding: T228.1.11.12

**Operational characteristics**

Fluid	Filtered air. No lubrication needed, if applied it shall be continuous
Max working pressure (bar)	10
Temperature °C	-5 ÷ +50
Flow rate at 6 bar with Δp=1 (NI/min)	620
Orifice size (mm)	6
Working ports size	G1/8"
Pilot ports size	G1/8"

TYPE	
① 32 = 3 ways	
52 = 5 ways	

Minimum piloting pressure 2,5 bar

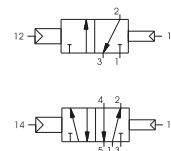

3 ways

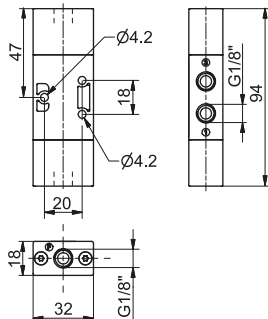

Weight 74 g

T228.32.11.12

5 ways

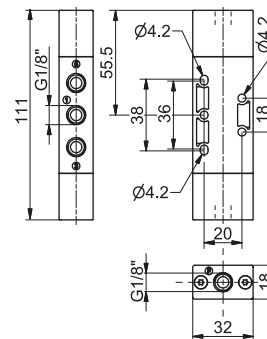

Weight 86 g

T228.52.11.12

**Pneumatic - Differential self aligned**

Coding: T228.1.11.12/1

**Operational characteristics**

Fluid	Filtered air. No lubrication needed, if applied it shall be continuous
Max working pressure (bar)	10
Temperature °C	-5 ÷ +50
Flow rate at 6 bar with Δp=1 (NI/min)	620
Orifice size (mm)	6
Working ports size	G1/8"
Pilot ports size	G1/8"

TYPE	
① 32 = 3 ways	
52 = 5 ways	

Minimum piloting pressure 2,5 bar

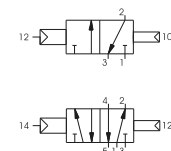

3 ways

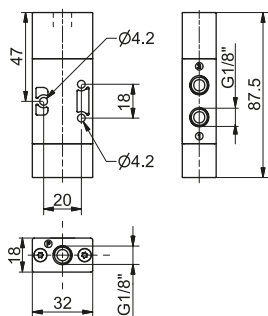

Weight 70 g

T228.32.11.12/1

5 ways

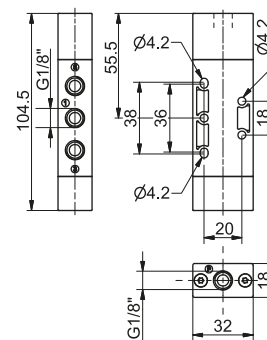

Weight 82 g

T228.52.11.12/1

**Pneumatic - Pneumatic**

Coding: T228.1.11.11

Operational characteristics	
Fluid	Filtered air. No lubrication needed, if applied it shall be continuous
Max working pressure (bar)	10
Temperature °C	-5 ÷ +50
Flow rate at 6 bar with Δp=1 (NI/min)	620
Orifice size (mm)	6
Working ports size	G1/8"
Pilot ports size	G1/8"

TYPE	
32	= 3 ways
52	= 5 ways

Minimum piloting pressure 2 bar

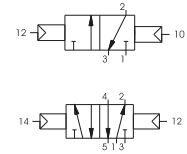

3 ways

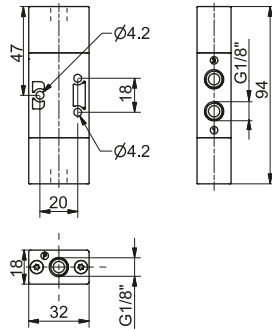

Weight 77 g

T228.32.11.11

5 ways

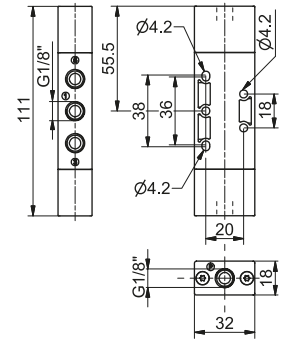

Weight 90 g

T228.52.11.11

**Pneumatic - Pneumatic 3 positions**

Coding: T228.53.1.11.11

Operational characteristics	
Fluid	Filtered air. No lubrication needed, if applied it shall be continuous
Max working pressure (bar)	10
Temperature °C	-5 ÷ +50
Flow rate at 6 bar with Δp=1 (NI/min)	410
Orifice size (mm)	6
Working ports size	G1/8"
Pilot ports size	G1/8"

FUNCTION	
31	= Closed centres
32	= Open centres
33	= Pressured centres

Minimum piloting pressure 3 bar

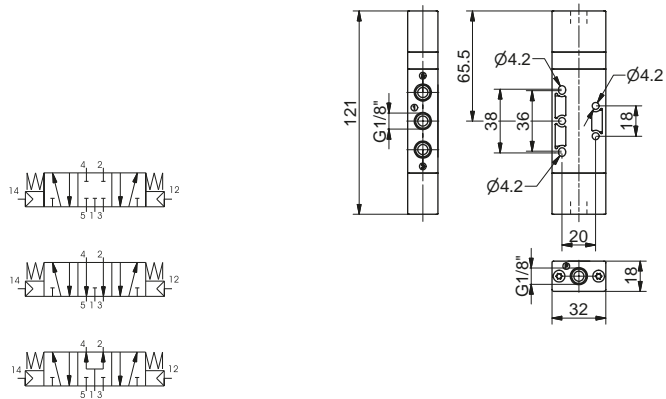

Weight 110 g

1  
AIR DISTRIBUTION

**Push button - Spring**

Coding: T224.1.8.1

**Operational characteristics**

Fluid	Filtered air. No lubrication needed, if applied it shall be continuous
Max working pressure (bar)	10
Temperature °C	-5 ÷ +50
Flow rate at 6 bar with Δp=1 (NI/min)	1050
Orifice size (mm)	8.5
Working ports size	G1/4"

TYPE	Operating force 50 N
1 32 = 3 ways	
52 = 5 ways	

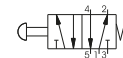
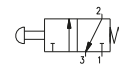

3 ways

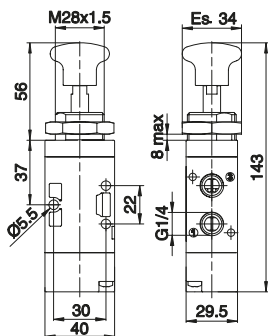

Weight 170 g

T224.32.8.1

5 ways

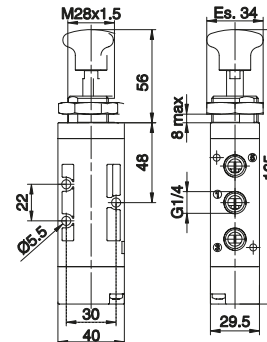

Weight 200 g

T224.52.8.1

**Push button 2 positions**

Coding: T224.1.8

**Operational characteristics**

Fluid	Filtered air. No lubrication needed, if applied it shall be continuous
Max working pressure (bar)	10
Temperature °C	-5 ÷ +50
Flow rate at 6 bar with Δp=1 (NI/min)	1050
Orifice size (mm)	8.5
Working ports size	G1/4"

TYPE	Operating force 13 N
1 32 = 3 ways	
52 = 5 ways	

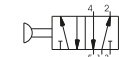
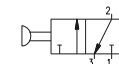

3 ways

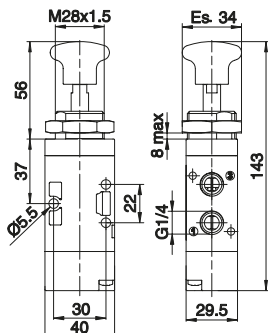

Weight 170 g

T224.32.8

5 ways

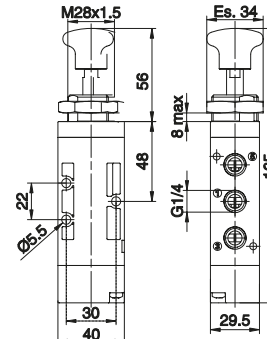

Weight 200 g

T224.52.8

**Lever lateral - Spring**

Coding: T224.1.9.1/C

**Operational characteristics**

Fluid	Filtered air. No lubrication needed, if applied it shall be continuous
Max working pressure (bar)	10
Temperature °C	-5 ÷ +50
Flow rate at 6 bar with Δp=1 (NI/min)	1050
Orifice size (mm)	8.5
Working ports size	G1/4"

TYPE	
1 32 = 3 ways	
52 = 5 ways	
LEVER COLOR	
1 = Red	
2 = Black	
3 = Green	

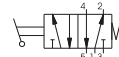
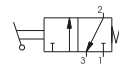

3 ways

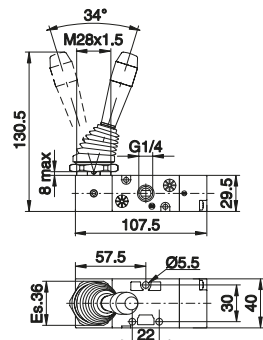

Weight 220 g

T224.32.9.1/C

5 ways

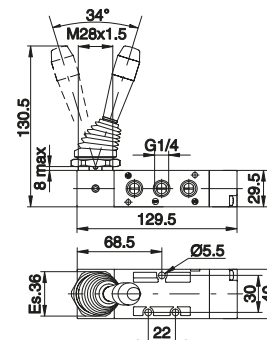

Weight 250 g

T224.52.9.1/C

AIR DISTRIBUTION

1

**Lever lateral 2 positions**

Coding: T224.1.9/C

Operational characteristics	
Fluid	Filtered air. No lubrication needed, if applied it shall be continuous
Max working pressure (bar)	10
Temperature °C	-5 ÷ +50
Flow rate at 6 bar with Δp=1 (NI/min)	1050
Orifice size (mm)	8.5
Working ports size	G1/4"

T	TYPE
	32 = 3 ways 52 = 5 ways
C	LEVER COLOR
	1 = Red 2 = Black 3 = Green

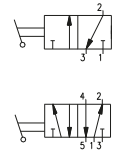

3 ways



Weight 220 g

T224.32.9/C

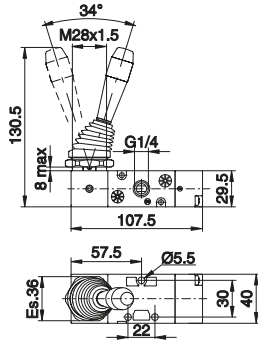

5 ways



Weight 250 g

T224.52.9/C

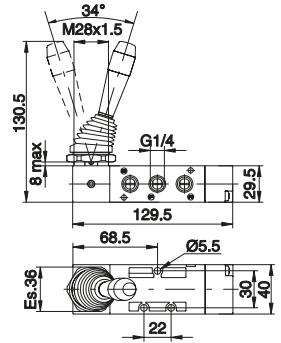

**Lever lateral 3 positions**

Coding: T224.53.F9.1/C

Operational characteristics	
Fluid	Filtered air. No lubrication needed, if applied it shall be continuous
Max working pressure (bar)	10
Temperature °C	-5 ÷ +50
Flow rate at 6 bar with Δp=1 (NI/min)	900
Orifice size (mm)	8.5
Working ports size	G1/4"

F	FUNCTION
	31 = Closed centres 32 = Open centres 33 = Pressured centres
	LEVER COLOR
C	1 = Red 2 = Black 3 = Green



Weight 270 g

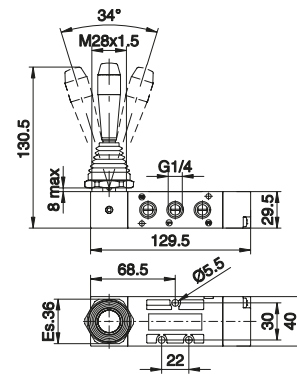
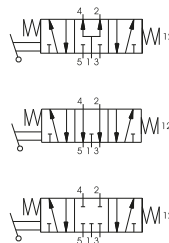

**Lateral lever - 3 positions detent**

Coding: T224.53.F9.1/C

Operational characteristics	
Fluid	Filtered air. No lubrication needed, if applied it shall be continuous
Max working pressure (bar)	10
Temperature °C	-5 ÷ +50
Flow rate at 6 bar with Δp=1 (NI/min)	900
Orifice size (mm)	8.5
Working ports size	G1/4"

F	FUNCTION
	31 = Closed centres 32 = Open centres 33 = Pressured centres
	LEVER COLOR
C	1 = Red 2 = Black 3 = Green



Weight 270 g

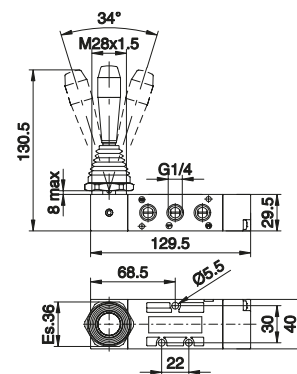
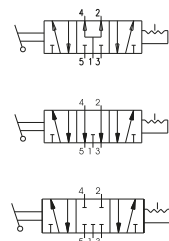

**Pneumatic - Spring**

Coding: T224.1.11.1

**Operational characteristics**

Fluid	Filtered air. No lubrication needed, if applied it shall be continuous
Max working pressure (bar)	10
Temperature °C	-5 ÷ +50
Flow rate at 6 bar with Δp=1 (NI/min)	1050
Orifice size (mm)	8.5
Working ports size	G1/4"
Pilot ports size	G1/8"

TYPE	
① 32 = 3 ways	
52 = 5 ways	

Minimum piloting pressure 2,5 bar

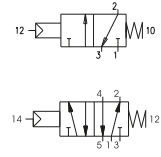

1  
AIR DISTRIBUTION

3 ways

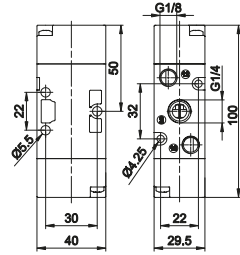

Weight 110 g

T224.32.11.1

5 ways

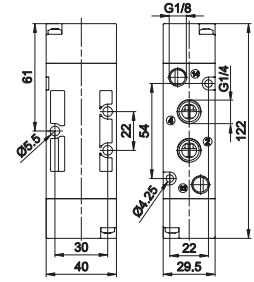

Weight 140 g

T224.52.11.1

**Pneumatic - Differential external**

Coding: T224.1.11.12

**Operational characteristics**

Fluid	Filtered air. No lubrication needed, if applied it shall be continuous
Max working pressure (bar)	10
Temperature °C	-5 ÷ +50
Flow rate at 6 bar with Δp=1 (NI/min)	1050
Orifice size (mm)	8.5
Working ports size	G1/4"
Pilot ports size	G1/8"

TYPE	
① 32 = 3 ways	
52 = 5 ways	

Minimum piloting pressure 2 bar

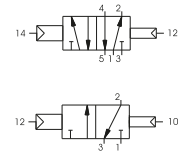

3 ways

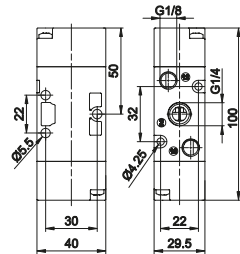

Weight 110 g

T224.32.11.12

5 ways

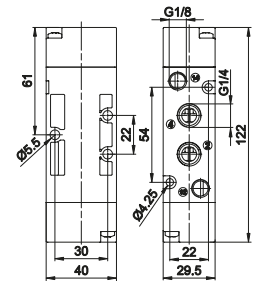

Weight 140 g

T224.52.11.12

**Pneumatic - Pneumatic**

Coding: T224.1.11.11

**Operational characteristics**

Fluid	Filtered air. No lubrication needed, if applied it shall be continuous
Max working pressure (bar)	10
Temperature °C	-5 ÷ +50
Flow rate at 6 bar with Δp=1 (NI/min)	1050
Orifice size (mm)	8.5
Working ports size	G1/4"
Pilot ports size	G1/8"

TYPE	
① 32 = 3 ways	
52 = 5 ways	

Minimum piloting pressure 2 bar

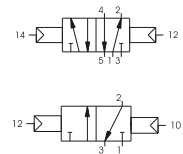

3 ways

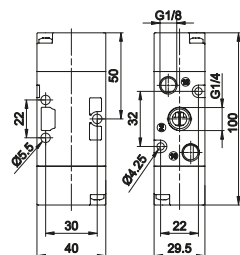

Weight 110 g

T224.32.11.11

5 ways

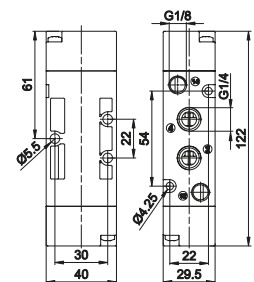

Weight 140 g

T224.52.11.11

**Pneumatic - Pneumatic 5 ways 3 connections**

Coding: T224.53.F.11.11

Operational characteristics	
Fluid	Filtered air. No lubrication needed, if applied it shall be continuous
Max working pressure (bar)	10
Temperature °C	-5 ÷ +50
Flow rate at 6 bar with Δp=1 (Nl/min)	900
Orifice size (mm)	8.5
Working ports size	G1/4"
Pilot ports size	G1/8"

FUNCTION	
F	31 = Closed centres
	32 = Open centres
	33 = Pressured centres

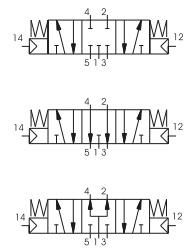
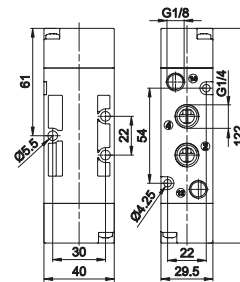

Weight 160 g  
Minimum piloting pressure 3 bar

1  
AIR DISTRIBUTION



## Series 800

### General

The trend towards the miniaturization of components has been consolidated. The use of new technologies makes it possible to manufacture components with high flow rates but extremely compact sizes.

Electric piloting is by means of low-absorption miniature solenoids which are easily connected to the electronic control systems of machines (PLC).

Another object of study have been manifolds and multiple bases for ganged assembly of valves or solenoid valves with option for having outlets 2 and 4 either on the valve body or on the base through threaded holes or integrated quick connections provided.

Versions 3/2 and 5/2 are fitted with pneumatic and electropneumatic controls with resetting by mechanically or pneumatically operated spring, or by pneumatic or electropneumatic operation on the bistable versions.

The basic difference between this type of distributors and the others we produce, based on the spool system, lies in the fact that the seals rest on the spool and are dynamic, instead of being locked into the spool the valve body by means of spacers. By this means a compact size is obtained and the distributors can be slotted into bases and manifolds by means of two screws.

### Construction characteristics

Body	Aluminium
Operators	Aluminium
Seals	HNBR
Spools	Aluminium
Springs	Stainless steel
Pistons	Aluminium

### Use and maintenance

These valves have an average life of 15 million cycles depending on the application and air quality.

Filtered and lubricated air using specified lubricants will reduce the wear of the seals and ensures long and trouble free operation.

Please ensure that the valve is being used according with the manufacturers specification, such as air pressure and temperature.

The exhaust port of the distributor has to be protected in a dusty and dirty environment.

Repair kits including the spool complete with seals are available for overhauling the valves.

However, although this is a simple operation it should be carried out by a competent person.

**ATTENTION:** use hydraulic oil class H for lubrication such as MAGNA GC 32 (Castrol).

### How to order the solenoid valves

Example:

**805.52.0.1.01** Solenoid valves with miniature solenoid 12 V D.C.

List of codes for tensions:

01 = miniature solenoid 12 VDC

02 = miniature solenoid 24 VDC

05 = miniature solenoid 24 VAC

06 = miniature solenoid 110 VAC

07 = miniature solenoid 220 VAC

The electropilot utilized is a 15 mm 3/2 N.C. miniature solenoid with faston and 1.1 mm orifice

Miniature solenoid homologated are available c  US (see series 300)



**Pneumatic - Spring**

Coding: 805.1.11.1

Operational characteristics	
Fluid	Filtered air. No lubrication needed, if applied it shall be continuous
Max working pressure (bar)	10
Temperature °C	-5 ÷ +70
Flow rate at 6 bar with Δp=1 (NI/min)	160
Orifice size (mm)	2.5
Working ports size	M5
Pilot ports size	M5

TYPE	
32	= 3 ways
52	= 5 ways

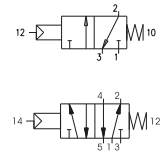

3 ways



Weight 45 g  
Minimum piloting pressure 2 bar

805.32.11.1

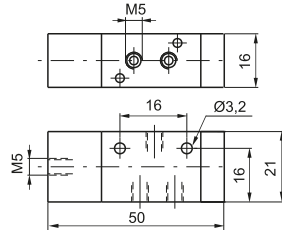

5 ways



Weight 50 g  
Minimum piloting pressure 2 bar

805.52.11.1

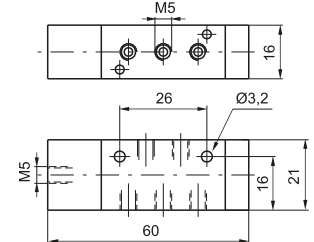

**Pneumatic - Differential**

Coding: 805.1.11.12

Operational characteristics	
Fluid	Filtered air. No lubrication needed, if applied it shall be continuous
Max working pressure (bar)	10
Temperature °C	-5 ÷ +70
Flow rate at 6 bar with Δp=1 (NI/min)	160
Orifice size (mm)	2.5
Working ports size	M5
Pilot ports size	M5

TYPE	
32	= 3 ways
52	= 5 ways

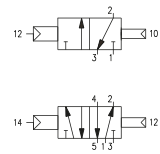

3 ways



Weight 50 g  
Minimum piloting pressure 2 bar

805.32.11.12

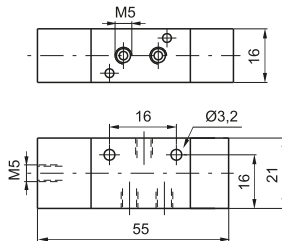

5 ways



Weight 55 g  
Minimum piloting pressure 2 bar

805.52.11.12

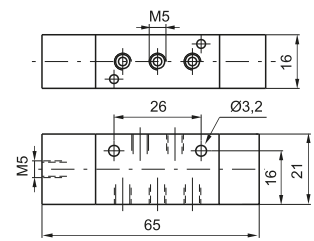

**Pneumatic - Pneumatic**

Coding: 805.1.11.11

Operational characteristics	
Fluid	Filtered air. No lubrication needed, if applied it shall be continuous
Max working pressure (bar)	10
Temperature °C	-5 ÷ +70
Flow rate at 6 bar with Δp=1 (NI/min)	160
Orifice size (mm)	2.5
Working ports size	M5
Pilot ports size	M5

TYPE	
32	= 3 ways
52	= 5 ways

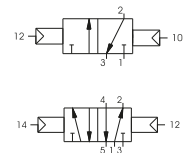

3 ways



Weight 55 g  
Minimum piloting pressure 1,5 bar

805.32.11.11

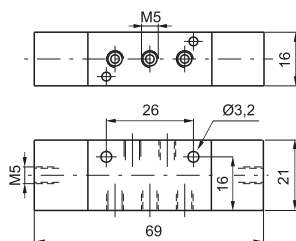

5 ways 2 connections



Weight 60 g  
Minimum piloting pressure 1,5 bar

805.52.11.11

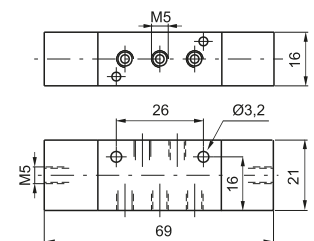

1  
AIR DISTRIBUTION



AIR DISTRIBUTION

**Solenoid - Spring**

Coding: 805.●.0.1.●

**Operational characteristics**

Fluid	Filtered air. No lubrication needed, if applied it shall be continuous
Max working pressure (bar)	10
Temperature °C	-5 ÷ +50
Flow rate at 6 bar with Δp=1 (NI/min)	160
Orifice size (mm)	2.5
Working ports size	M5

TYPE	VOLTAGE
● 32 = 3 ways	● 01 = 12V D.C.
● 52 = 5 ways	● 02 = 24V D.C.
	● 05 = 24V A.C.
	● 06 = 110V A.C.
	● 07 = 230V A.C.

3 ways

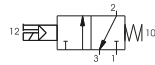
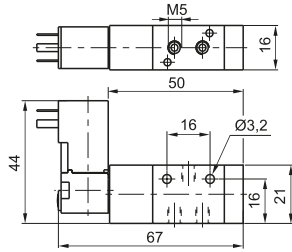

Weight 80 g  
Minimum working pressure 2 bar

805.32.0.1.●

5 ways

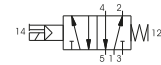
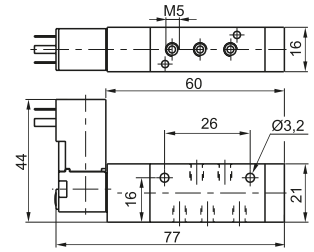

Weight 85 g  
Minimum working pressure 2 bar

805.52.0.1.●

**Solenoid - Differential**

Coding: 805.●.0.12.●

**Operational characteristics**

Fluid	Filtered air. No lubrication needed, if applied it shall be continuous
Max working pressure (bar)	10
Temperature °C	-5 ÷ +50
Flow rate at 6 bar with Δp=1 (NI/min)	160
Orifice size (mm)	2.5
Working ports size	M5

TYPE	VOLTAGE
● 32 = 3 ways	● 01 = 12V D.C.
● 52 = 5 ways	● 02 = 24V D.C.
	● 05 = 24V A.C.
	● 06 = 110V A.C.
	● 07 = 230V A.C.

3 ways

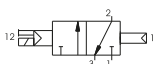
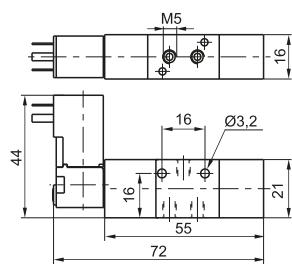

Weight 85 g  
Minimum working pressure 2 bar

805.32.0.12.●

5 ways

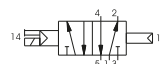
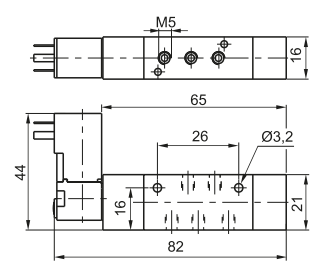

Weight 90 g  
Minimum working pressure 2 bar

805.52.0.12.●

**Solenoid - Solenoid**

Coding: 805.●.0.0.●

**Operational characteristics**

Fluid	Filtered air. No lubrication needed, if applied it shall be continuous
Max working pressure (bar)	10
Temperature °C	-5 ÷ +50
Flow rate at 6 bar with Δp=1 (NI/min)	160
Orifice size (mm)	2.5
Working ports size	M5

TYPE	VOLTAGE
● 32 = 3 ways	● 01 = 12V D.C.
● 52 = 5 ways	● 02 = 24V D.C.
	● 05 = 24V A.C.
	● 06 = 110V A.C.
	● 07 = 230V A.C.

3 ways

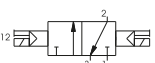
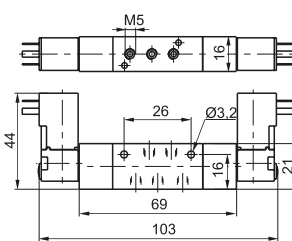

Weight 120 g  
Minimum working pressure 1,5 bar

805.32.0.0.●

5 ways

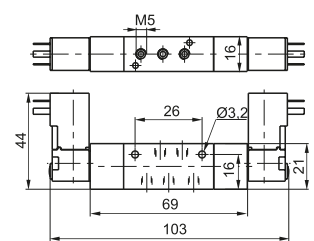

Weight 125 g  
Minimum working pressure 1,5 bar

805.52.0.0.●

Collectors

Coding: 805.N



N. POSITIONS
02 = 2 positions (weight 95 g)
03 = 3 positions (weight 130 g)
04 = 4 positions (weight 160 g)
05 = 5 positions (weight 190 g)
06 = 6 positions (weight 225 g)
07 = 7 positions (weight 260 g)
08 = 8 positions (weight 290 g)
09 = 9 positions (weight 325 g)
10 = 10 positions (weight 365 g)

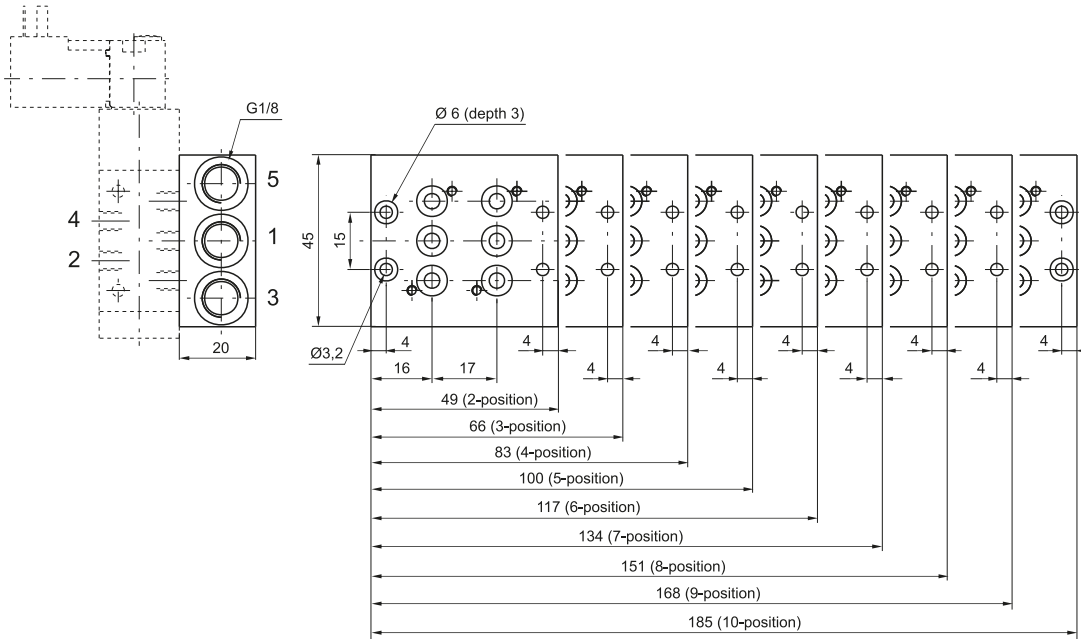

1

AIR DISTRIBUTION

Clip

Coding: 800.00

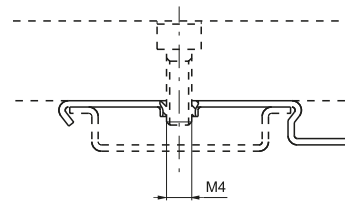

weight 5 g  
(for mounting the distributors groups on guide DIN 46277/3)

Closing plate

Coding: 805.00

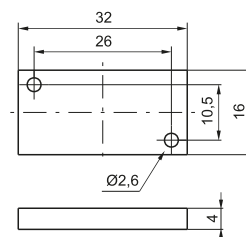

weight 15 g

**Pneumatic - Spring**

Coding: 808.11.1

**Operational characteristics**

Fluid	Filtered air. No lubrication needed, if applied it shall be continuous
Max working pressure (bar)	10
Temperature °C	-5 ÷ +70
Flow rate at 6 bar with Δp=1 (NI/min)	520
Orifice size (mm)	4
Working ports size	G1/8"
Pilot ports size	M5

TYPE
① 32 = 3 ways
52 = 5 ways

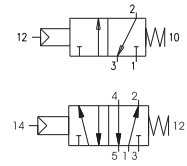

*Pneumatic - Spring*

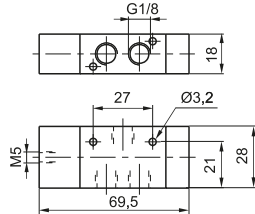

Weight 95 g  
Minimum piloting pressure 2 bar

808.32.11.1

*Pneumatic - Spring*

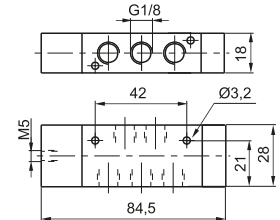

Weight 100 g  
Minimum piloting pressure 2 bar

808.52.11.1

**Pneumatic - Differential**

Coding: 808.11.12

**Operational characteristics**

Fluid	Filtered air. No lubrication needed, if applied it shall be continuous
Max working pressure (bar)	10
Temperature °C	-5 ÷ +70
Flow rate at 6 bar with Δp=1 (NI/min)	520
Orifice size (mm)	4
Working ports size	G1/8"
Pilot ports size	M5

TYPE
① 32 = 3 ways
52 = 5 ways

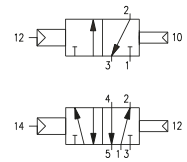

*Pneumatic - Differential external*

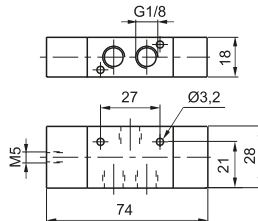

Weight 105 g  
Minimum piloting pressure 2 bar

808.32.11.12

*Pneumatic - Differential external*

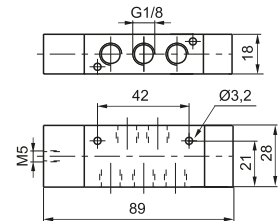

Weight 110 g  
Minimum piloting pressure 2 bar

808.52.11.12

**Pneumatic - Pneumatic**

Coding: 808.11.11

**Operational characteristics**

Fluid	Filtered air. No lubrication needed, if applied it shall be continuous
Max working pressure (bar)	10
Temperature °C	-5 ÷ +70
Flow rate at 6 bar with Δp=1 (NI/min)	520
Orifice size (mm)	4
Working ports size	G1/8"
Pilot ports size	M5

TYPE
① 32 = 3 ways
52 = 5 ways

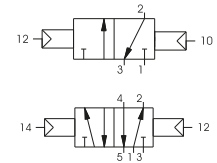

*Pneumatic-pneumatic*

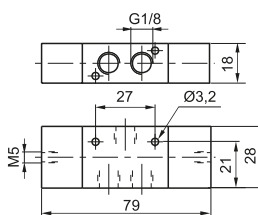

Weight 115 g  
Minimum piloting pressure 1,5 bar

808.32.11.11

*Pneumatic-pneumatic*

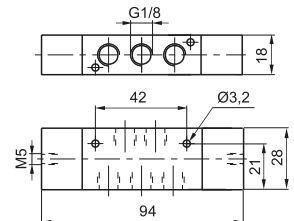

Weight 120 g  
Minimum piloting pressure 1,5 bar

808.52.11.11

**Pneumatic - Pneumatic**

Coding: 808.53.1.11.11

Operational characteristics	
Fluid	Filtered air. No lubrication needed, if applied it shall be continuous
Max working pressure (bar)	10
Temperature °C	-5 ÷ +70
Flow rate at 6 bar with Δp=1 (l/min)	520
Orifice size (mm)	4
Working ports size	G 1/8"
Pilot ports size	M5

TYPE	
31	= Closed centres
32	= Open centres

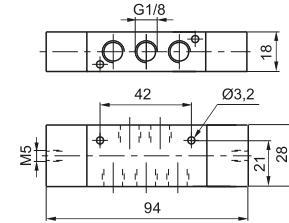
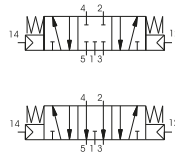

Weight 125 g  
Minimum piloting pressure 3 bar

1  
AIR DISTRIBUTION

**Solenoid - Spring**

Coding: 808.0.0.1.V

**Operational characteristics**

Fluid	Filtered air. No lubrication needed, if applied it shall be continuous
Max working pressure (bar)	10
Temperature °C	-5 ÷ +50
Flow rate at 6 bar with Δp=1 (NI/min)	520
Orifice size (mm)	4
Working ports size	G 1/8"

TYPE	
32 = 3 ways	
52 = 5 ways	

VOLTAGE	
01 = 12V D.C.	
02 = 24V D.C.	
05 = 24V A.C.	
06 = 110V A.C.	
07 = 230V A.C.	

3 ways

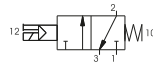
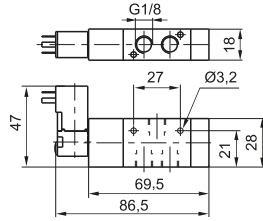

Weight 130 g  
Minimum working pressure 2 bar

808.32.0.1.V

5 ways

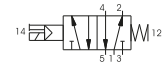
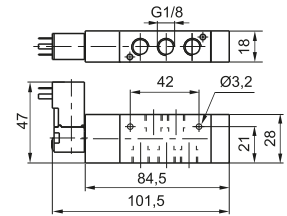

Weight 135 g  
Minimum working pressure 2 bar

808.52.0.1.V

**Solenoid - Differential**

Coding: 808.0.0.12.V

**Operational characteristics**

Fluid	Filtered air. No lubrication needed, if applied it shall be continuous
Max working pressure (bar)	10
Temperature °C	-5 ÷ +50
Flow rate at 6 bar with Δp=1 (NI/min)	520
Orifice size (mm)	4
Working ports size	G 1/8"

TYPE	
32 = 3 ways	
52 = 5 ways	

VOLTAGE	
01 = 12V D.C.	
02 = 24V D.C.	
05 = 24V A.C.	
06 = 110V A.C.	
07 = 230V A.C.	

3 ways

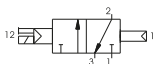
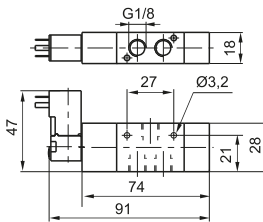

Weight 140 g  
Minimum working pressure 2 bar

808.32.0.12.V

5 ways

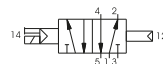
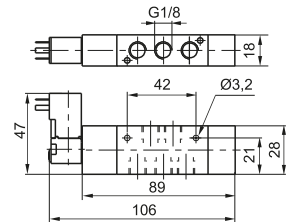

Weight 145 g  
Minimum working pressure 2 bar

808.52.0.12.V

**Solenoid - Solenoid**

Coding: 808.0.0.0.V

**Operational characteristics**

Fluid	Filtered air. No lubrication needed, if applied it shall be continuous
Max working pressure (bar)	10
Temperature °C	-5 ÷ +50
Flow rate at 6 bar with Δp=1 (NI/min)	520
Orifice size (mm)	4
Working ports size	G 1/8"

TYPE	
32 = 3 ways	
52 = 5 ways	

VOLTAGE	
01 = 12V D.C.	
02 = 24V D.C.	
05 = 24V A.C.	
06 = 110V A.C.	
07 = 230V A.C.	

3 ways

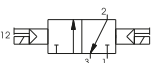
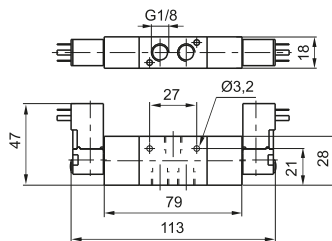

Weight 185 g  
Minimum working pressure 1,5 bar

808.32.0.0.V

5 ways

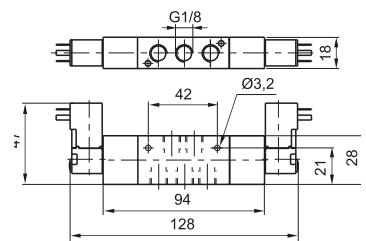

Weight 190 g  
Minimum working pressure 1,5 bar

808.52.0.0.V

AIR DISTRIBUTION

1

**Solenoid - Solenoid 5 ways 3 connections**

Coding: 808.53.①.0.0.②

Operational characteristics	
Fluid	Filtered air. No lubrication needed, if applied it shall be continuous
Max working pressure (bar)	10
Temperature °C	-5 ÷ +50
Flow rate at 6 bar with Δp=1 (Nl/min)	520
Orifice size (mm)	4
Working ports size	G 1/8"

TYPE		VOLTAGE	
①	31 = Closed centres	②	01 = 12V D.C.
	32 = Open centres	②	02 = 24V D.C.
		②	05 = 24V A.C.
		②	06 = 110V A.C.
		②	07 = 230 V.A.C.



Weight 190 g  
Minimum working pressure 3 bar

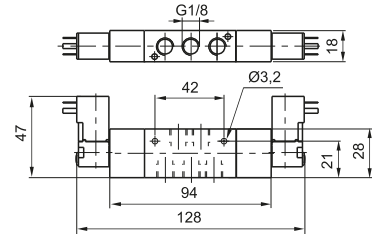
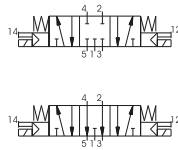

1

AIR DISTRIBUTION



Collectors

Coding: 808.N



N. POSITIONS	
02	= 2 positions (weight 180 g)
03	= 3 positions (weight 245 g)
04	= 4 positions (weight 310 g)
05	= 5 positions (weight 375 g)
06	= 6 positions (weight 440 g)
07	= 7 positions (weight 500 g)
08	= 8 positions (weight 560 g)
09	= 9 positions (weight 620 g)
10	= 10 positions (weight 680 g)

1

AIR DISTRIBUTION

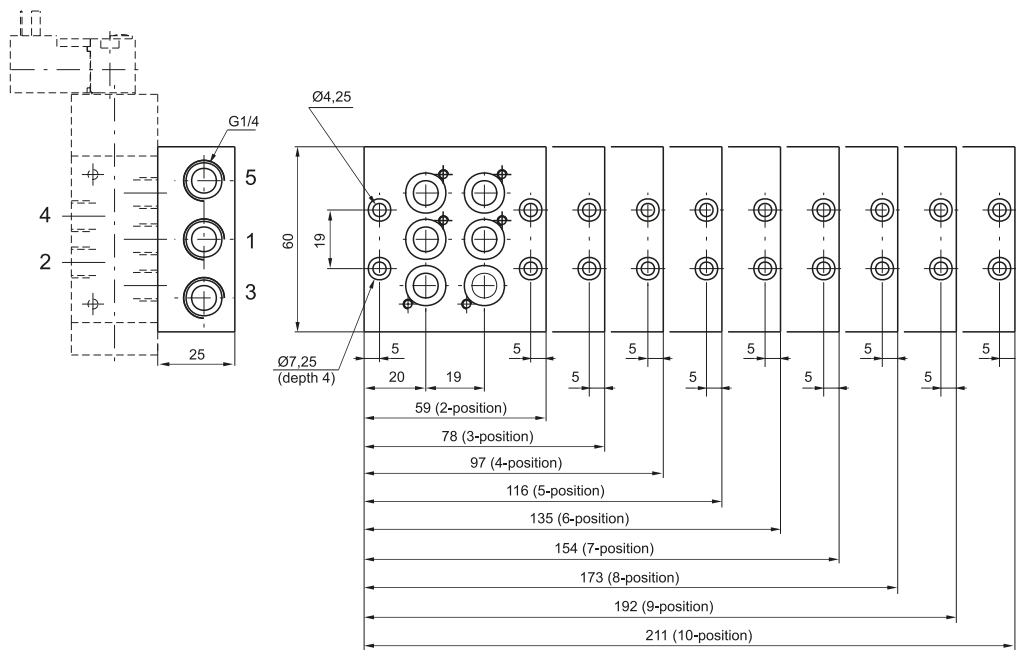

Clip

Coding: 800.00

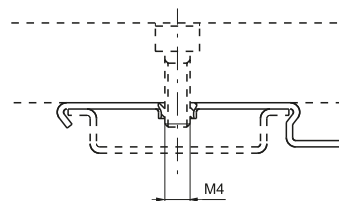

weight 5 g  
(for mounting the distributors groups on guide DIN 46277/3)

Closing plate

Coding: 808.00

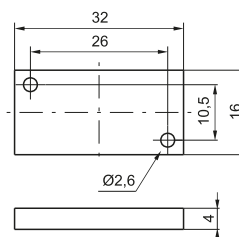

Weight 65 g





## Series 888

### General

Competitively priced, good performance and versatility combined with a compact design are the main characteristics of this new series of valves.

The aluminium valve body and spool/seal arrangement optimize both the flow rate and the valve switching time.

This series of valves are available with G1/8" and G1/4" ports in 3/2, 5/2 and 5/3 versions.

Monostable or bistable versions are available and include an integrated technopolymer solenoid operator with 9mm stem and built in manual override.

**Solenoid valves series 888 are available in point-to-point and serial configurations.**

**For serial system specifications, see Optyma-F series.**

The valves can be supplied with or without the solenoid coil, however, if the solenoid coil is required please refer to the following table:

Voltages		Coil Code	Voltage Code
Direct current DC	12V (3,5W)	MF4	F04
	24V (3,5W)	MF5	F05
Alternating current AC 50 - 60 Hz	24V (3,7W)	MF56	F56
	110V (3,7W)	MF57	F57
	230V (3,7W)	MF58	F58

Connectors Coding		
Voltages		Kit 100 pieces
DC/AC	24V	888.11.01L-K
Alternating current AC 50 - 60 Hz	110V	888.11.02L-K
	230V	888.11.03L-K

### Construction characteristics

Body	Aluminium
Operators	Technopolymer Aluminium for spring bottom plates
Seals	NBR
Spools	Aluminium
Springs	Spring steel
Pistons	Technopolymer

### Use and maintenance

These valves have an average life of 15 million cycles depending on the application and air quality, filtered and lubricated air using specified lubricants will dramatically reduce the wear of the seals and ensures long and trouble free operation.

Please ensure that the valve is being used according with the manufacturers specification, such as air pressure and temperature.

The exhaust ports 3 and 5 must be protected against the possible ingress of dirt or debris.

Repair kits including the spool complete with seals are available for overhauling the valves; however, although this is a simple operation it should be carried out by a competent person.

1  
AIR DISTRIBUTION

**Solenoid - Spring - 3/2 (Self-feeding)**

Coding: 8880.32.ⓕ.39.Ⓥ

Operational characteristics	
Fluid	Filtered air. No lubrication needed, if applied it shall be continuous
Max working pressure (bar)	8
Temperature °C	-5 ÷ +50
Flow rate at 6 bar with Δp=1 (NI/min)	790
Orifice size (mm)	5.8
Working ports size	G 1/8"

FUNCTION	
ⓕ	A = Normally Open
	C = Normally Closed

VOLTAGE	
F04	= 12 V DC
F05	= 24 V DC
Ⓥ F56	= 24 V (50-60 Hz)
F57	= 110 V (50-60 Hz)
F58	= 230 V (50-60 Hz)
F00	= Without coil

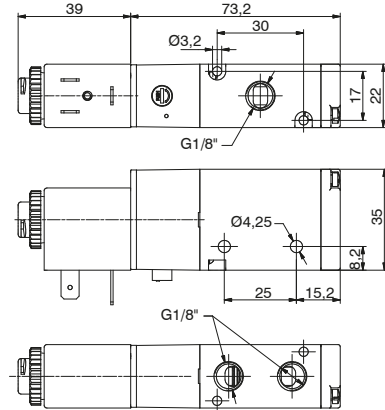
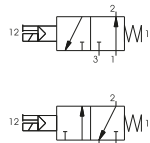

Weight 210 g  
Minimum working pressure 2 bar

**Solenoid - Spring - 5/2 (Self-feeding)**

Coding: 8880.52.00.39.Ⓥ

Operational characteristics	
Fluid	Filtered air. No lubrication needed, if applied it shall be continuous
Max working pressure (bar)	8
Temperature °C	-5 ÷ +50
Flow rate at 6 bar with Δp=1 (NI/min)	790
Orifice size (mm)	5.8
Working ports size	G 1/8"

VOLTAGE	
F04	= 12 V DC
F05	= 24 V DC
Ⓥ F56	= 24 V (50-60 Hz)
F57	= 110 V (50-60 Hz)
F58	= 230 V (50-60 Hz)
F00	= Without coil

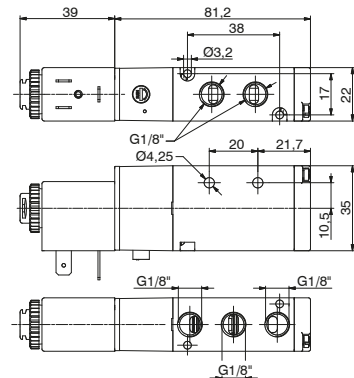

Weight 220 g  
Minimum working pressure 2 bar

**Solenoid - Solenoid - 3/2**

Coding: 8880.32.00.35.Ⓥ

Operational characteristics	
Fluid	Filtered air. No lubrication needed, if applied it shall be continuous
Max working pressure (bar)	8
Temperature °C	-5 ÷ +50
Flow rate at 6 bar with Δp=1 (NI/min)	790
Orifice size (mm)	5.8
Working ports size	G 1/8"

VOLTAGE	
F04	= 12 V DC
F05	= 24 V DC
Ⓥ F56	= 24 V (50-60 Hz)
F57	= 110 V (50-60 Hz)
F58	= 230 V (50-60 Hz)
F00	= Without coil

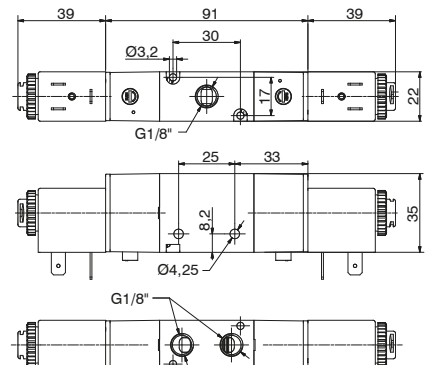
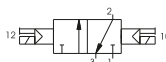

Weight 310 g  
Minimum working pressure 2 bar

**Solenoid - Solenoid - 5 ways 2 connections**

Coding: 8880.52.00.35. **V**

Operational characteristics	
Fluid	Filtered air. No lubrication needed, if applied it shall be continuous
Max working pressure (bar)	8
Temperature °C	-5 ÷ +50
Flow rate at 6 bar with Δp=1 (NI/min)	790
Orifice size (mm)	5.8
Working ports size	G 1/8"

VOLTAGE	
F04	= 12 VDC
F05	= 24 VDC
<b>F56</b>	= 24 V (50-60 Hz)
F57	= 110 V (50-60 Hz)
F58	= 230 V (50-60 Hz)
F00	= Without coil



Weight 320 g  
Minimum working pressure 2 bar

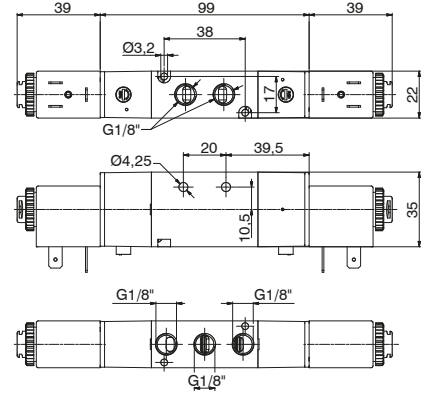
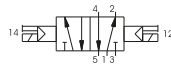

**Solenoid - Solenoid - 5 ways 3 connections**

Coding: 8880.53. **F**.35. **V**

Operational characteristics	
Fluid	Filtered air. No lubrication needed, if applied it shall be continuous
Max working pressure (bar)	8
Temperature °C	-5 ÷ +50
Flow rate at 6 bar with Δp=1 (NI/min)	440
Orifice size (mm)	5.8
Working ports size	G 1/8"

FUNCTION		VOLTAGE	
<b>F</b>	31 = Closed centres	F04	= 12 VDC
	32 = Open centres	F05	= 24 VDC
	33 = Pressured centres	<b>F56</b>	= 24 V (50-60 Hz)
		F57	= 110 V (50-60 Hz)
		F58	= 230 V (50-60 Hz)
		F00	= Without coil



Weight 330 g  
Minimum working pressure 2,5 bar

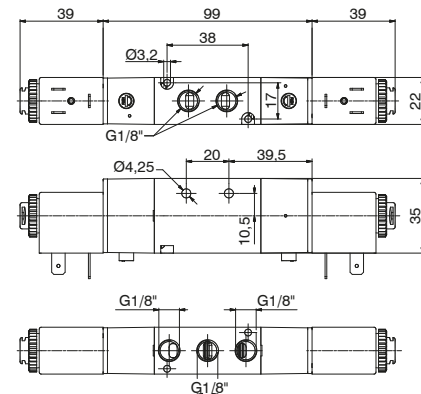
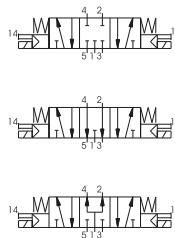

**Solenoid - Spring - 3/2 (External-feeding)**

Coding: 8880E.32. **F**.39. **V**

Operational characteristics	
Fluid	Filtered air. No lubrication needed, if applied it shall be continuous
Max working pressure (bar)	8
Temperature °C	-5 ÷ +50
Flow rate at 6 bar with Δp=1 (NI/min)	790
Orifice size (mm)	5.8
Working ports size	G 1/8"

FUNCTION		VOLTAGE	
<b>F</b>	A = 3/2 Normally Open	F04	= 12 VDC
	C = 3/2 Normally Closed	F05	= 24 VDC
		<b>F56</b>	= 24 V (50-60 Hz)
		F57	= 110 V (50-60 Hz)
		F58	= 230 V (50-60 Hz)
		F00	= Without coil



Weight 210 g  
Minimum working pressure 2 bar

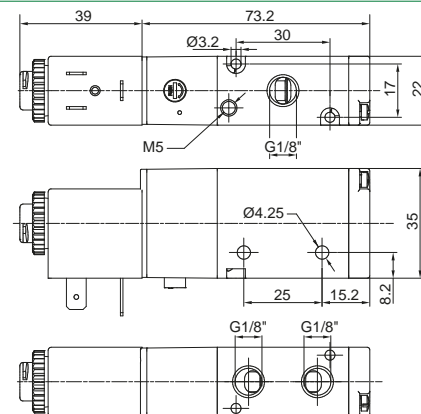
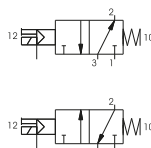

**Solenoid - Spring - 5/2 (External-feeding)**

Coding: 8880E.52.00.39.

Operational characteristics	
Fluid	Filtered air. No lubrication needed, if applied it shall be continuous
Max working pressure (bar)	8
Temperature °C	-5 ÷ +50
Flow rate at 6 bar with Δp=1 (NI/min)	790
Orifice size (mm)	5.8
Working ports size	G 1/8"

VOLTAGE	
F04	= 12 VDC
F05	= 24 VDC
F56	= 24 V (50-60 Hz)
F57	= 110 V (50-60 Hz)
F58	= 230 V (50-60 Hz)
F00	= Without coil



Weight 220 g  
Minimum working pressure 2 bar

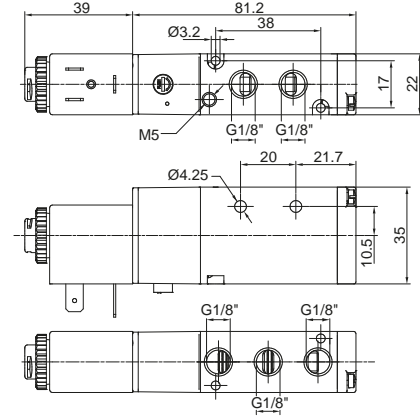
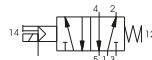

**Solenoid - Solenoid - 3/2 (External-feeding)**

Coding: 8880E.32.00.35.

Operational characteristics	
Fluid	Filtered air. No lubrication needed, if applied it shall be continuous
Max working pressure (bar)	8
Temperature °C	-5 ÷ +50
Flow rate at 6 bar with Δp=1 (NI/min)	790
Orifice size (mm)	5.8
Working ports size	G 1/8"

VOLTAGE	
F04	= 12 VDC
F05	= 24 VDC
F56	= 24 V (50-60 Hz)
F57	= 110 V (50-60 Hz)
F58	= 230 V (50-60 Hz)
F00	= Without coil



Weight 310 g  
Minimum working pressure 2 bar

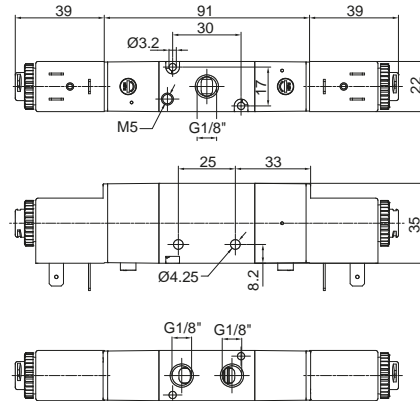
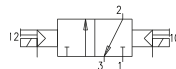

**Solenoid - Solenoid - 5/2 (External-feeding)**

Coding: 8880E.52.00.35.

Operational characteristics	
Fluid	Filtered air. No lubrication needed, if applied it shall be continuous
Max working pressure (bar)	8
Temperature °C	-5 ÷ +50
Flow rate at 6 bar with Δp=1 (NI/min)	790
Orifice size (mm)	5.8
Working ports size	G 1/8"

VOLTAGE	
F04	= 12 VDC
F05	= 24 VDC
F56	= 24 V (50-60 Hz)
F57	= 110 V (50-60 Hz)
F58	= 230 V (50-60 Hz)
F00	= Without coil



Weight 320 g  
Minimum working pressure 2 bar

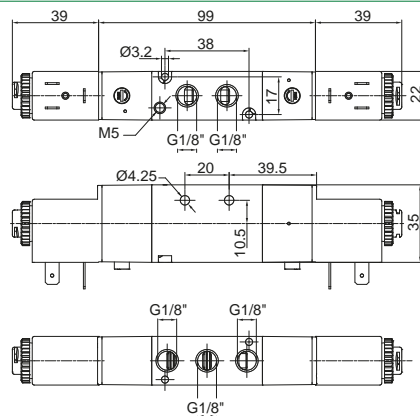

**Solenoid - Solenoid - 5/3 connections (External-feeding)**

Operational characteristics	
Fluid	Filtered air. No lubrication needed, if applied it shall be continuous
Max working pressure (bar)	8
Temperature °C	-5 ÷ +50
Flow rate at 6 bar with Δp=1 (NI/min)	440
Orifice size (mm)	5.8
Working ports size	G 1/8"

Coding: 8880E.53.ⓕ.35.Ⓥ

FUNCTION		VOLTAGE	
ⓕ	31 = Closed centres	Ⓥ	F04 = 12 VDC
	32 = Open centres		F05 = 24 VDC
	33 = Pressured centres		F56 = 24 V (50-60 Hz)
			F57 = 110 V (50-60 Hz)
			F58 = 230 V (50-60 Hz)
			F00 = Without coil

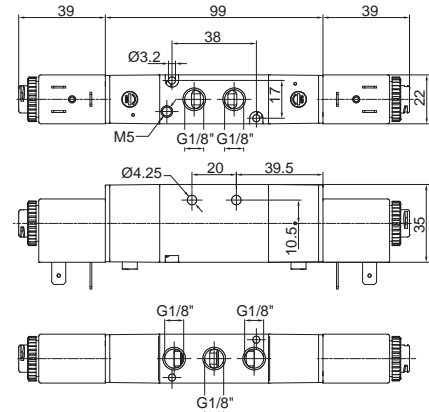
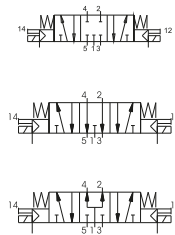

Weight 330 g  
Minimum working pressure 2,5 bar

**Solenoid - Spring - 3/2 (Self-feeding)**

Operational characteristics	
Fluid	Filtered air. No lubrication needed, if applied it shall be continuous
Max working pressure (bar)	8
Temperature °C	-5 ÷ +50
Flow rate at 6 bar with Δp=1 (NI/min)	890
Orifice size (mm)	6.5
Working ports size	G 1/4"

Coding: 8884.32.ⓕ.39.Ⓥ

FUNCTION		VOLTAGE	
ⓕ	A = 3/2 Normally Open	Ⓥ	F04 = 12 VDC
	C = 3/2 Normally Closed		F05 = 24 VDC
			F56 = 24 V (50-60 Hz)
			F57 = 110 V (50-60 Hz)
			F58 = 230 V (50-60 Hz)
			F00 = Without coil

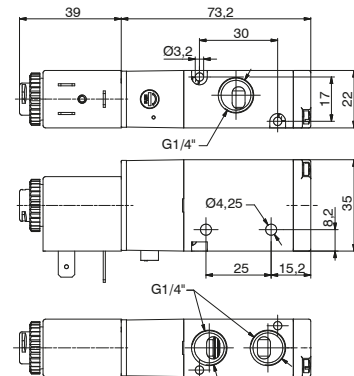
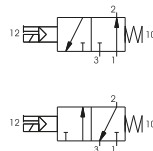

Weight 210 g  
Minimum working pressure 2 bar

**Solenoid - Spring - 5/2 (Self-feeding)**

Operational characteristics	
Fluid	Filtered air. No lubrication needed, if applied it shall be continuous
Max working pressure (bar)	8
Temperature °C	-5 ÷ +50
Flow rate at 6 bar with Δp=1 (NI/min)	890
Orifice size (mm)	6.5
Working ports size	G 1/4"

Coding: 8884.52.00.39.Ⓥ

VOLTAGE	
Ⓥ	F04 = 12 VDC
	F05 = 24 VDC
	F56 = 24 V (50-60 Hz)
	F57 = 110 V (50-60 Hz)
	F58 = 230 V (50-60 Hz)
	F00 = Without coil

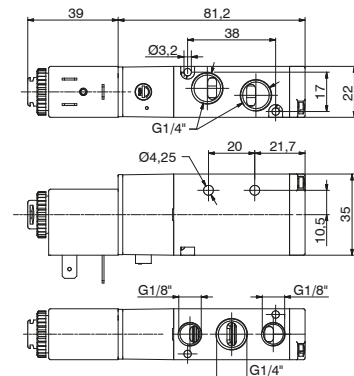
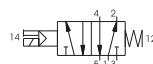

Weight 220 g  
Minimum working pressure 2 bar

**Solenoid - Solenoid - 3/2**

Coding: 8884.32.00.35.

**Operational characteristics**

Fluid	Filtered air. No lubrication needed, if applied it shall be continuous
Max working pressure (bar)	8
Temperature °C	-5 ÷ +50
Flow rate at 6 bar with Δp=1 (Nl/min)	890
Orifice size (mm)	6.5
Working ports size	G 1/4"

VOLTAGE	
F04	= 12 VDC
F05	= 24 VDC
F56	= 24 V (50-60 Hz)
F57	= 110 V (50-60 Hz)
F58	= 230 V (50-60 Hz)
F00	= Without coil

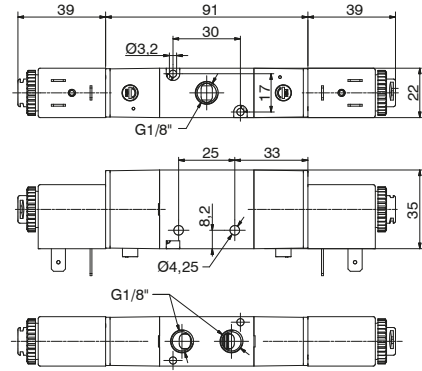
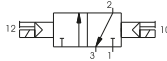
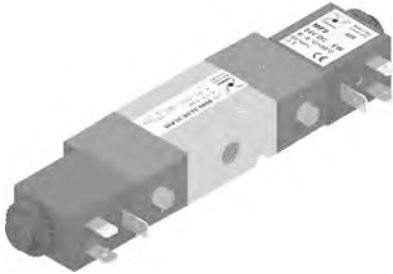

Weight 310 g  
Minimum working pressure 2 bar

**Solenoid - Solenoid - 5/2**

Coding: 8884.52.00.35.

**Operational characteristics**

Fluid	Filtered air. No lubrication needed, if applied it shall be continuous
Max working pressure (bar)	8
Temperature °C	-5 ÷ +50
Flow rate at 6 bar with Δp=1 (Nl/min)	540
Orifice size (mm)	6.5
Working ports size	G 1/4"

VOLTAGE	
F04	= 12 VDC
F05	= 24 VDC
F56	= 24 V (50-60 Hz)
F57	= 110 V (50-60 Hz)
F58	= 230 V (50-60 Hz)
F00	= Without coil

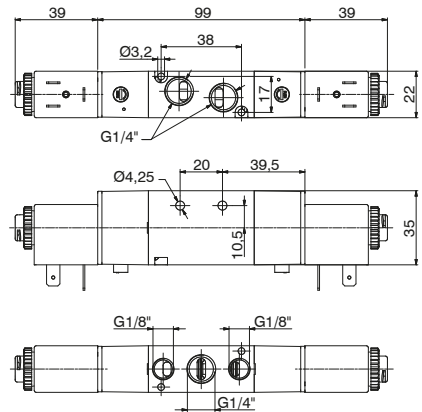

Weight 320 g  
Minimum working pressure 2 bar

**Solenoid - Solenoid - 5/3**

Coding: 8884.53.00.35.

**Operational characteristics**

Fluid	Filtered air. No lubrication needed, if applied it shall be continuous
Max working pressure (bar)	8
Temperature °C	-5 ÷ +50
Flow rate at 6 bar with Δp=1 (Nl/min)	540
Orifice size (mm)	6.5
Working ports size	G 1/4"

FUNCTION	
F31	= Closed centres
F32	= Open centres
F33	= Pressured centres

VOLTAGE	
F04	= 12 VDC
F05	= 24 VDC
F56	= 24 V (50-60 Hz)
F57	= 110 V (50-60 Hz)
F58	= 230 V (50-60 Hz)
F00	= Without coil

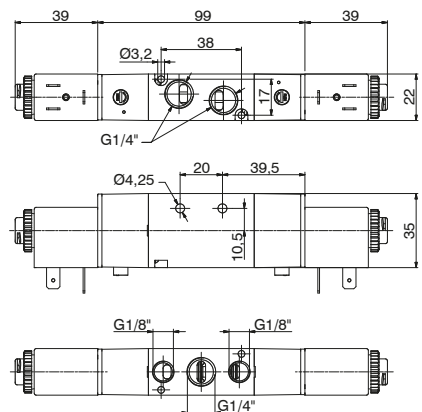
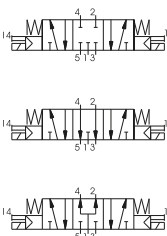
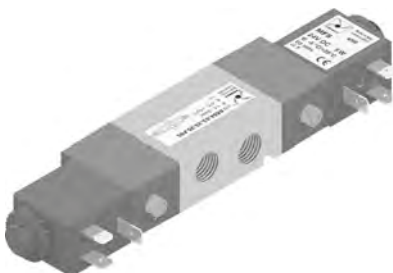

Weight 330 g  
Minimum working pressure 2,5 bar

Manifold (Valves 5/2 - 5/3)

Coding: 888.P



CONNECTION TYPE	
02	= nr. 2 positions (270 g)
03	= nr. 3 positions (335 g)
04	= nr. 4 positions (400 g)
05	= nr. 5 positions (465 g)
06	= nr. 6 positions (530 g)
<b>P</b> 07	= nr. 7 positions (595 g)
08	= nr. 8 positions (660 g)
09	= nr. 9 positions (725 g)
10	= nr. 10 positions (790 g)
12	= nr. 12 positions (920 g)
16	= nr. 16 positions (1180 g)

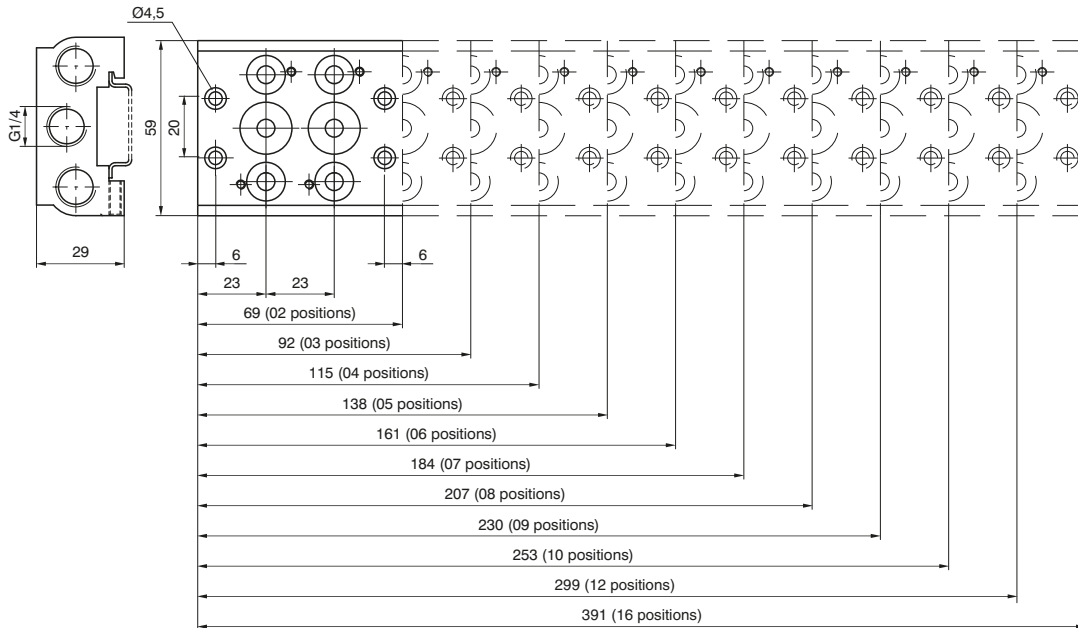

weight 5 g  
(for mounting the distributors groups on guide DIN 46277/3)

Closing plate

Coding: 888.00

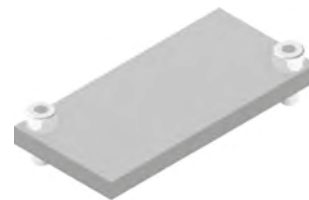
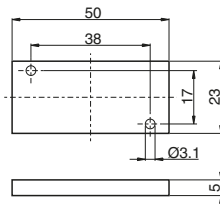

Weight 18 g  
Closing plate supplied complete with 2 fixing screws to the manifold and 2 fixing screws to the multi-polar base



▶ **Manifold (Valves 3/2)**

Coding: 8883.Ⓟ



CONNECTION TYPE	
02	= nr. 2 positions (270 g)
03	= nr. 3 positions (335 g)
04	= nr. 4 positions (400 g)
05	= nr. 5 positions (465 g)
Ⓟ 06	= nr. 6 positions (530 g)
07	= nr. 7 positions (595 g)
08	= nr. 8 positions (660 g)
09	= nr. 9 positions (725 g)
10	= nr. 10 positions (790 g)
12	= nr. 12 positions (920 g)
16	= nr. 16 positions (1180 g)

1  
AIR DISTRIBUTION

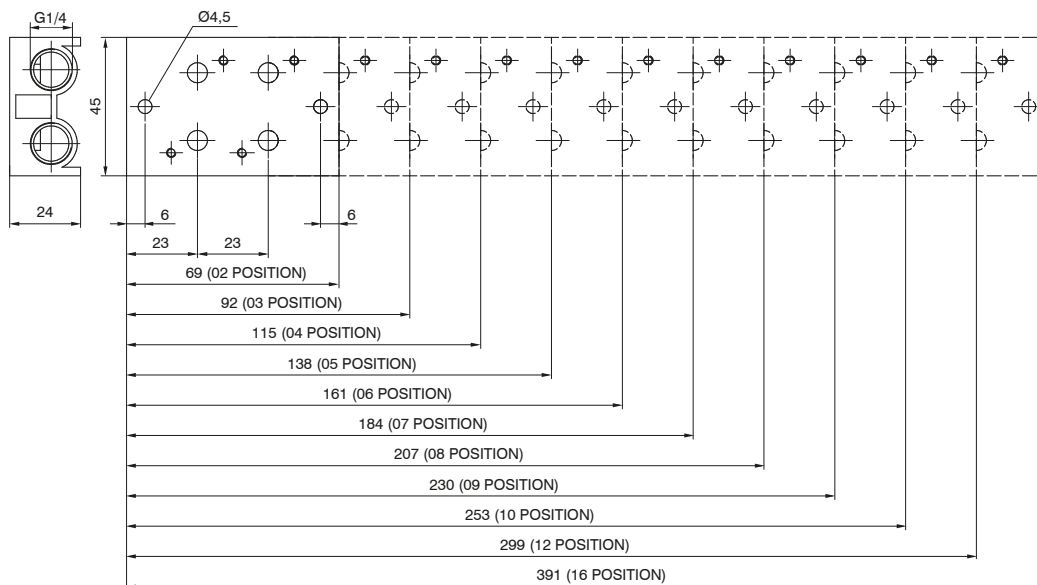

weight 5 g  
(for mounting the distributors groups on guide DIN 46277/3)

▶ **Closing plate**

Coding: 8883.00

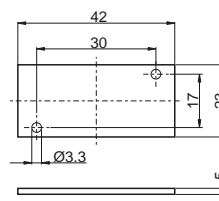
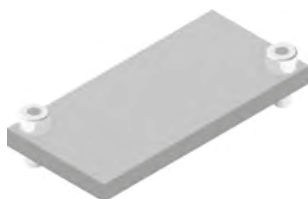

Weight 10 g  
Closing plate supplied complete with 2 fixing screws to the manifold



**Endplate, 37 Poles IP65**

Coding: 888M.37.10



Weight 186 g  
The IP65 protection is obtained by IP65 Pneumax cable.  
Code complete with assembled endplate and 4 manifold fixing screws, previously mounted on the Manifold.

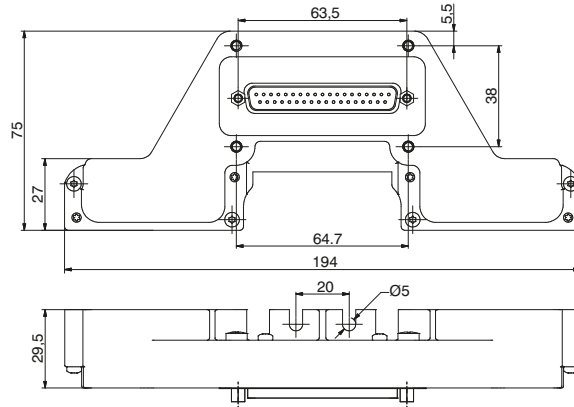

**Endplate, 25 Poles IP65**

Coding: 888M.25.10



Weight 181 g  
The IP65 protection is obtained by IP65 Pneumax cable.  
Code complete with assembled endplate and 4 manifold fixing screws, previously mounted on the Manifold.

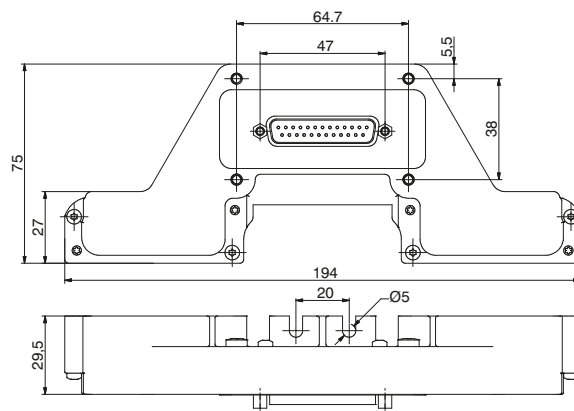

**Modular base, 2 positions IP65**

Coding: 888M.02.BM



Weight 220 g  
Complete with seals and fixing screws  
Usable only for 5/2 and 5/3 Distributors

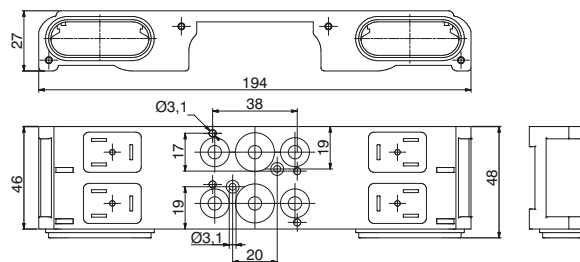

**Left and Right Power board PNP 24 VDC**

Coding: 888M.**P**.**T**

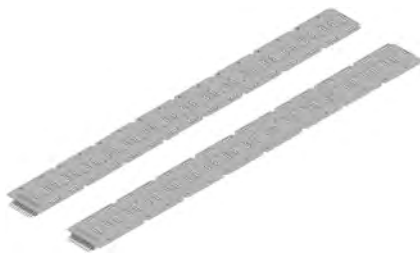

weight 5 g  
(for mounting the distributors groups on guide DIN 46277/3)

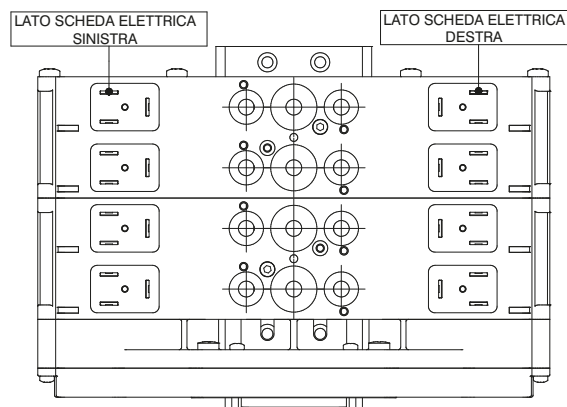

POSITIONS	
	04 = nr. 4 positions (11,2 g)
<b>P</b>	08 = nr. 8 positions (22,4 g)
	12 = nr. 12 positions (33,6 g)
	16 = nr. 16 positions (44,8 g)
TYPE	
<b>T</b>	00 = Left
	01 = Right

1  
AIR DISTRIBUTION

► Closing plate

Coding: 888M.22.PC

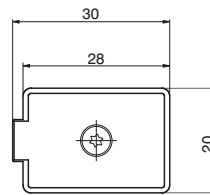

Weight 3 g  
Closing plate supplied complete with 1 Seal and fixing screw with O ring  
Maximum fixing torque for fittings: 0,35Nm

► Multipolar base plug

Coding: 888M.T

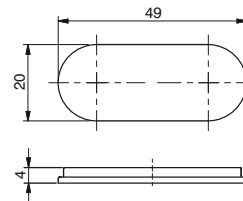

Weight 2,6 g  
Complete with: Nr. 1 Plug, Nr. 2 Fixing screws

► Seals

Coding: 888M.22.G

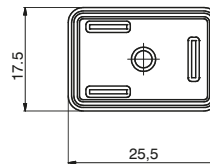

Weight 0,52 g

► In line cable complete with connector IP40

Coding: 2400.Ⓡ.Ⓛ.00



	CONNECTORS
Ⓡ	25 = 25 poles
	37 = 37 poles
	CABLE LENGTH
Ⓛ	03 = 3 meters
	05 = 5 meters
	10 = 10 meters

► Cable complete with connector, 25 Poles IP65

Coding: 2300.25.Ⓛ.Ⓒ



	CABLE LENGTH
Ⓛ	03 = 3 meters
	05 = 5 meters
	10 = 10 meters
	CONNECTOR
Ⓒ	10 = In line
	90 = 90° Angle

► Cable complete with connector, 37 Poles IP65

Coding: 2400.37.Ⓛ.Ⓒ



	CABLE LENGTH
Ⓛ	03 = 3 meters
	05 = 5 meters
	10 = 10 meters
	CONNECTOR
Ⓒ	10 = In line
	90 = 90° Angle



**Manifold layout Configuration Point to Point**

**3/2 valves**

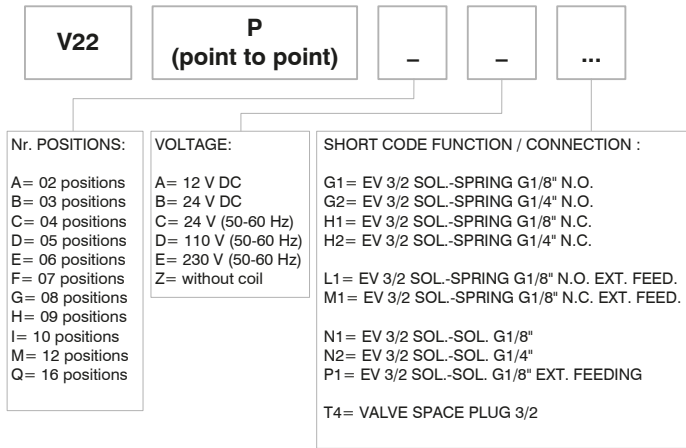

**5/2 valves**

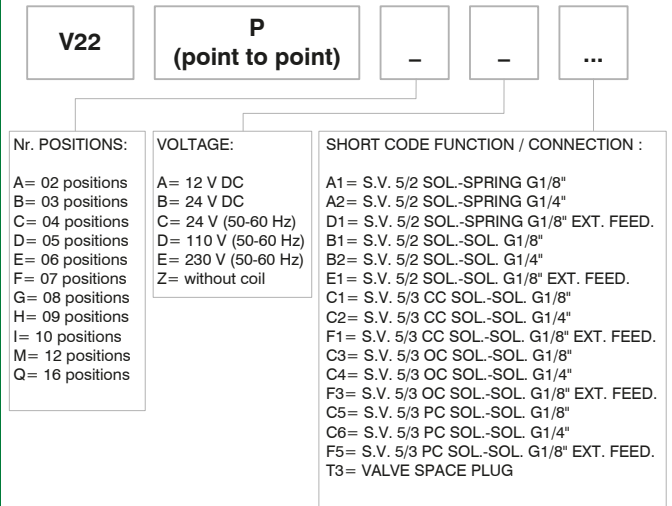

**Manifold layout Configuration Multi-pole**

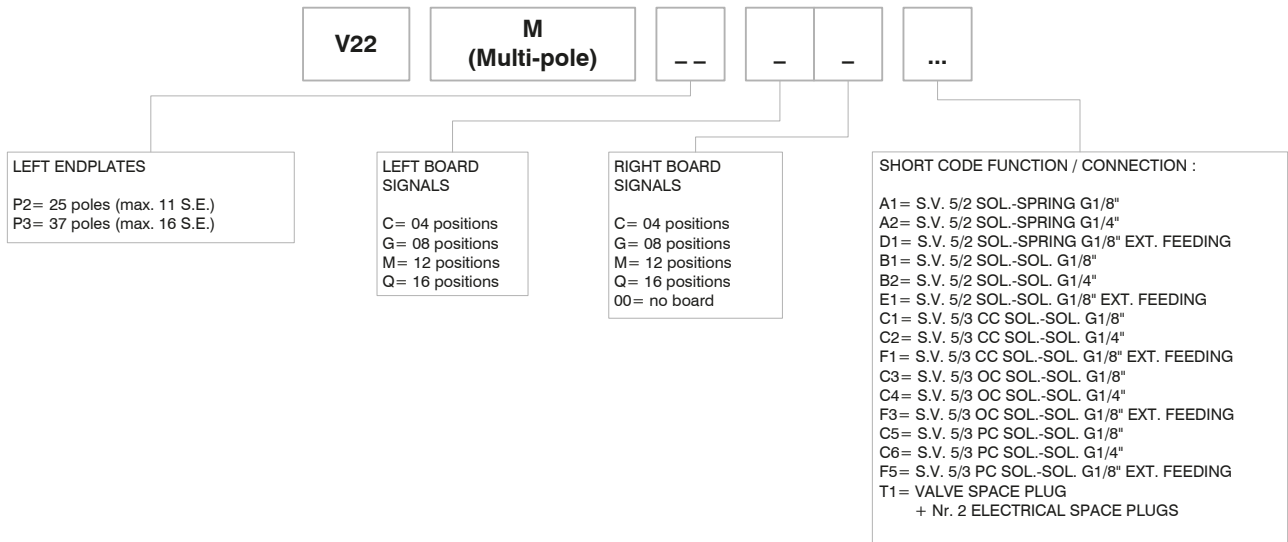

**Serial manifold layout (for the serial system node, see the Optyma-F Series)**

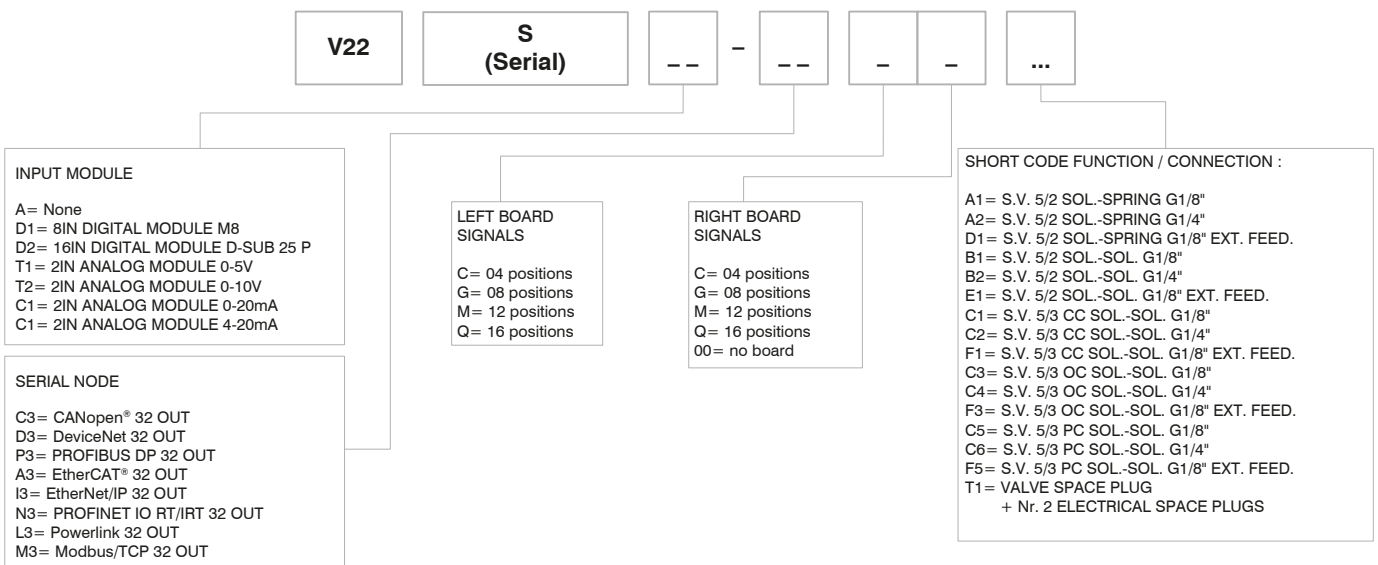

**NOTE:**

When constructing the configuration, please consider that the maximum number of valves that can be mounted on the manifold is 16, regardless of the valve type. Any valve position presents two electrical connections: in case of use of monostable valves (A1-A2) it will be necessary to assemble a plug to protect the unused electrical connection.

The correspondence between the electrical signal and its location on the manifold is showed in the following diagrams.

1  
AIR DISTRIBUTION

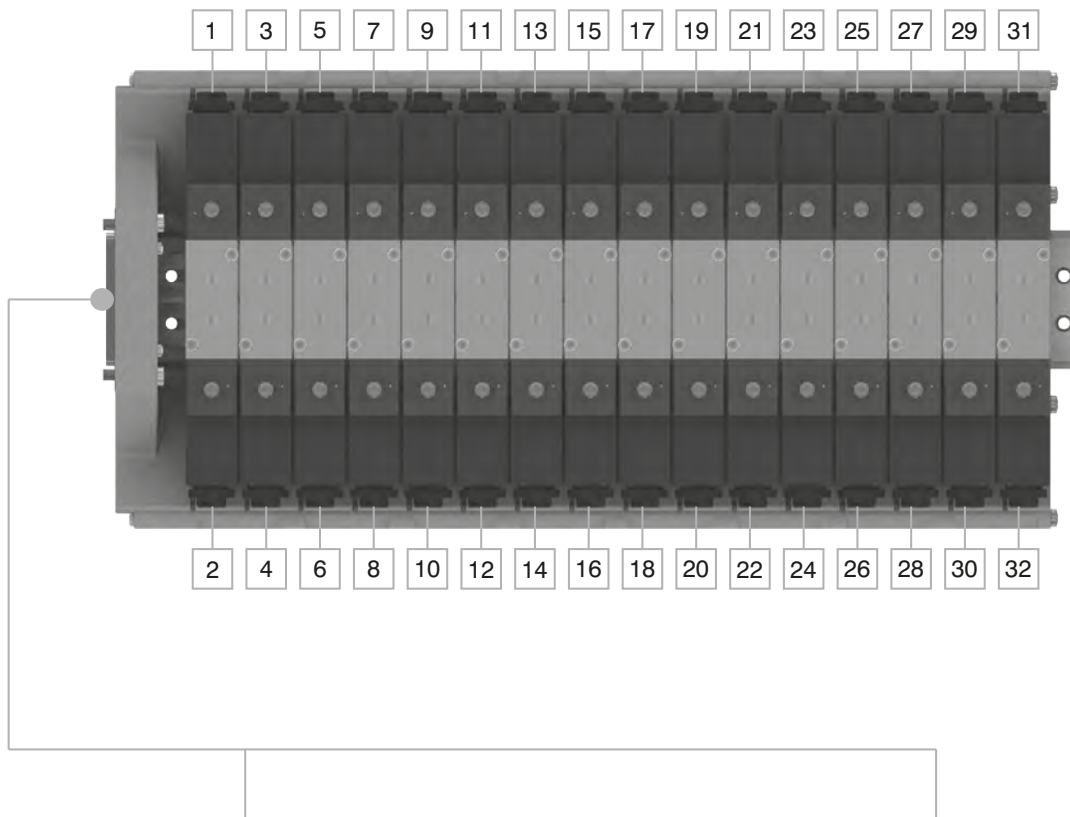

1  
AIR DISTRIBUTION

Connector 25 Poles from 1 to 11  
Positions E.V. Bistable / Monostable

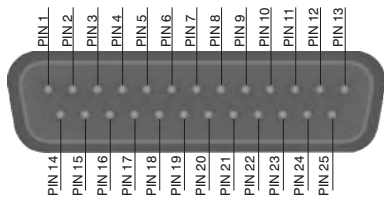

1 - 22 = SIGNALS  
23 - 24 = GND  
25 = NC

Connector 37 Poles from 1 to 16  
Positions E.V. Bistable / Monostable

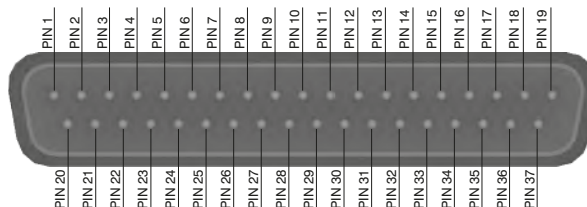

1 - 32 = SIGNALS  
33 - 35 = GND  
36 - 37 = NC

**Assembly sequence**

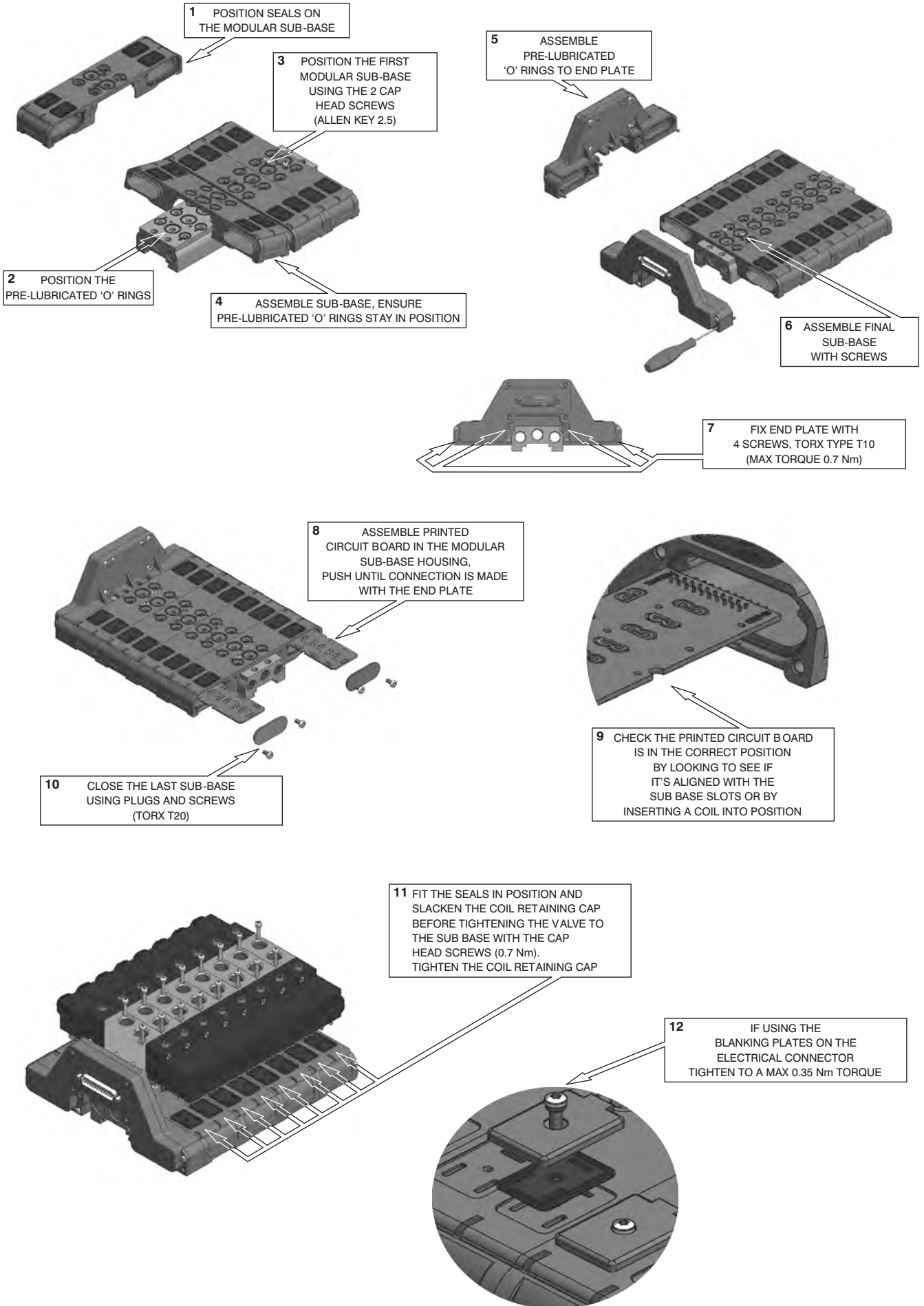

1  
AIR DISTRIBUTION



**Series 400**

**General**

These are 2 stage valves actuated electro-pneumatically. A serie 300 directly operated solenoid valve actuates pneumatically the principal power distributor.

This integrated system allows configurations of systems requiring very little space.

The pilot air is normally taken from the inlet port (autofeed) and the only actuating signal is electric.

The range of the solenoid valves, as far as dimensions and mechanical construction, is similar to series 200.

We have therefore solenoid valves G 1/8", G 1/4", G 1/2" and G 1" with identical pneumatic characteristics that are, however, actuated electrically.

They have a balanced spool, insensitive to presence or absence of pressure. They are constructed in 3 and 5 way with 1 solenoid (monostable) or 2 solenoids (bistable) and also 5 ways 3 positions with closed centres, open centres and pressured centres.

It should be noted that the autofeed of the electric pilot requires always inlet through port 1 and if a 3 ways normally open configuration is desired, it is necessary to switch the operators.

Solenoid valves G 1/8" and G 1/4" can be equipped with microsolenoids as well as standard solenoids and they can be mounted in line or in 90 degrees on valves.

Please note that while the microsolenoid can be mounted in any direction, standard solenoid requires mounting as indicated in the photographs and diagrams.

**The order codes pertain only to the solenoid valve with mechanical actuator "M2" or solenoid "S\*" already assembled.**

**M2 coils are not included and have to be ordered separately (see Series 300).**

**Coils for M2 and solenoids "S" homologated are available in 24V DC (see Series 300).**

**Construction characteristics**

Body	Aluminium
Operators	Aluminium Technopolymer for spring bottom plate G 1/8", G1/4", G 1/2" and aluminium for G 1"
Seals	NBR Polyurethane compound for oil free applications (G 1/8", G 1/4" and G 1/2")
Spacer	Technopolymer (aluminium for G1")
Spools	Steel
Springs	Stainless steel or spring steel

**Use and maintenance**

This valves have an average life of 15 million cycles depending on the application and air quality.

Filtered and lubricated air using specified lubricants will reduce the wear of the seals and ensures long and trouble free operation.

Please ensure that the valve is being used according with the manufacturers specification, such as air pressure and temperature.

The exhaust port of the distributor has to be protected in a dusty and dirty environment.

Repair kits including the spool complete with seals are available for overhauling the valves.

However, although this is a simple operation it should be carried out by a competent person.

**ATTENTION:** use hydraulic oil class H for lubrication such as MAGNA GC 32 (Castrol).

1 AIR DISTRIBUTION

**Solenoid - Spring**

Coding: 468.0.0.1.M2

Operational characteristics	
Fluid	Filtered air. No lubrication needed, if applied it shall be continuous
Max working pressure (bar)	10
Temperature °C	-5 ÷ +50
Flow rate at 6 bar with Δp=1 (NI/min)	540
Orifice size (mm)	6
Working ports size	G 1/8"

TYPE	
32	= 3 ways
52	= 5 ways

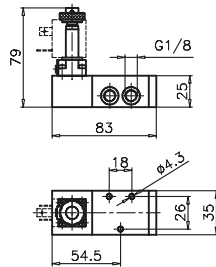
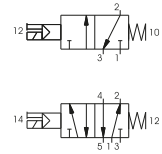

Weight 240 g  
Minimum working pressure 2,5 bar  
468.32.0.1.M2

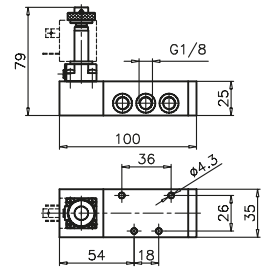

Weight 240 g  
Minimum working pressure 2,5 bar  
468.52.0.1.M2

**Solenoid - Differential**

Coding: 468.0.0.12.M2

Operational characteristics	
Fluid	Filtered air. No lubrication needed, if applied it shall be continuous
Max working pressure (bar)	10
Temperature °C	-5 ÷ +50
Flow rate at 6 bar with Δp=1 (NI/min)	540
Orifice size (mm)	6
Working ports size	G 1/8"

TYPE	
32	= 3 ways
52	= 5 ways

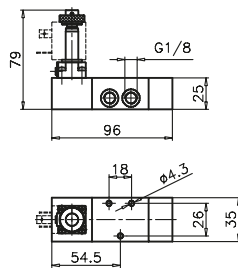
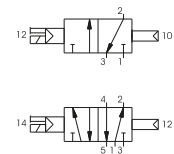

Weight 280 g  
Minimum working pressure 2,5 bar  
468.32.0.12.M2

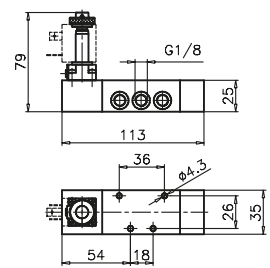

Weight 320 g  
Minimum working pressure 2,5 bar  
468.52.0.12.M2

**Solenoid - Solenoid**

Coding: 468.0.0.0.M2

Operational characteristics	
Fluid	Filtered air. No lubrication needed, if applied it shall be continuous
Max working pressure (bar)	10
Temperature °C	-5 ÷ +50
Flow rate at 6 bar with Δp=1 (NI/min)	540
Orifice size (mm)	6
Working ports size	G 1/8"

TYPE	
32	= 3 ways
52	= 5 ways

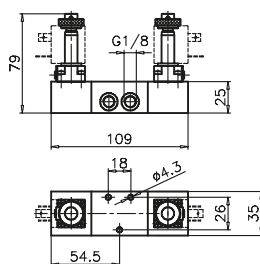
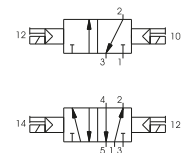

Weight 370 g  
Minimum working pressure 2 bar  
468.32.0.0.M2

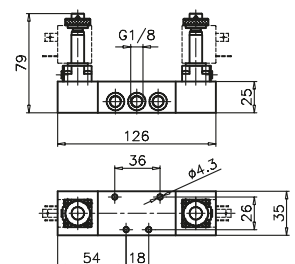

Weight 410 g  
Minimum working pressure 2 bar  
468.52.0.0.M2

**Solenoid - Solenoid 5 ways 3 connections**

Coding: 468.53.F.0.0.M2

**Operational characteristics**

Fluid	Filtered air. No lubrication needed, if applied it shall be continuous
Max working pressure (bar)	10
Temperature °C	-5 ÷ +50
Flow rate at 6 bar with Δp=1 (NI/min)	410
Orifice size (mm)	6
Working ports size	G 1/8"

FUNCTION	
F	31 = Closed centres
	32 = Open centres
	33 = Pressured centres

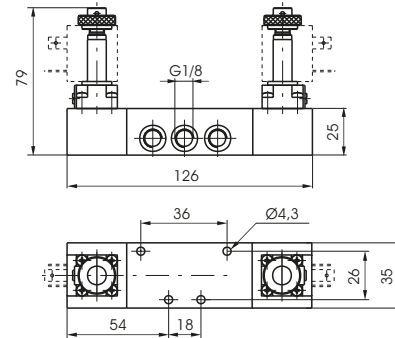
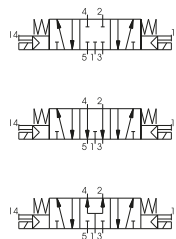

Weight 420 g  
Minimum working pressure 3 bar

**Solenoid - Spring**

Coding: 468/1.T.0.1.M2

**Operational characteristics**

Fluid	Filtered air. No lubrication needed, if applied it shall be continuous
Max working pressure (bar)	10
Temperature °C	-5 ÷ +50
Flow rate at 6 bar with Δp=1 (NI/min)	540
Orifice size (mm)	6
Working ports size	G 1/8"

TYPE	
T	32 = 3 ways
	52 = 5 ways

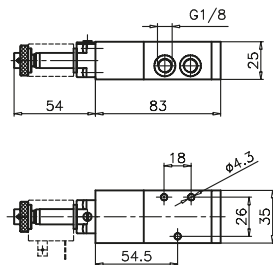
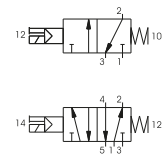

Weight 240 g  
Minimum working pressure 2,5 bar

468/1.32.0.1.M2

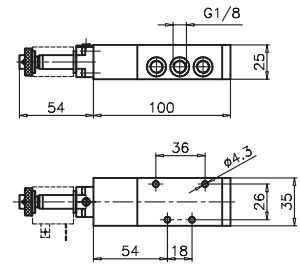

Weight 280 g  
Minimum working pressure 2,5 bar

468/1.52.0.1.M2

**Solenoid - Differential**

Coding: 468/1.T.0.12.M2

**Operational characteristics**

Fluid	Filtered air. No lubrication needed, if applied it shall be continuous
Max working pressure (bar)	10
Temperature °C	-5 ÷ +50
Flow rate at 6 bar with Δp=1 (NI/min)	540
Orifice size (mm)	6
Working ports size	G 1/8"

TYPE	
T	32 = 3 ways
	52 = 5 ways

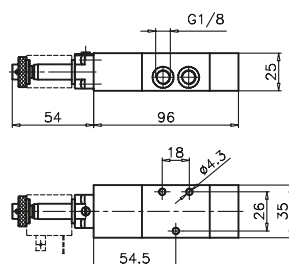
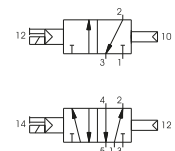

Weight 280 g  
Minimum working pressure 2,5 bar

468/1.32.0.12.M2

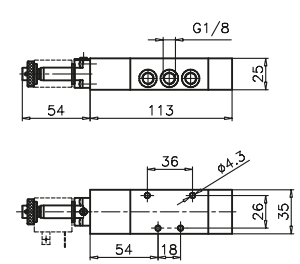

Weight 320 g  
Minimum working pressure 2,5 bar

468/1.52.0.12.M2



**Solenoid - Solenoid**

Coding: 468/1.1.0.0.M2

Operational characteristics	
Fluid	Filtered air. No lubrication needed, if applied it shall be continuous
Max working pressure (bar)	10
Temperature °C	-5 ÷ +50
Flow rate at 6 bar with Δp=1 (NI/min)	540
Orifice size (mm)	6
Working ports size	G 1/8"

TYPE	
32	= 3 ways
52	= 5 ways

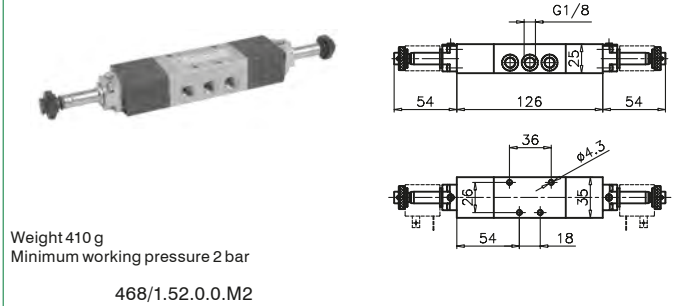
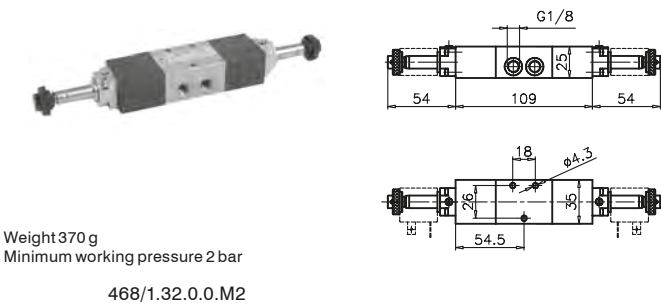
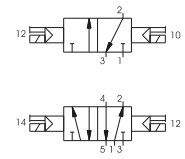

**Solenoid - Solenoid 5 ways 3 connections**

Coding: 468/1.53.0.0.M2

Operational characteristics	
Fluid	Filtered air. No lubrication needed, if applied it shall be continuous
Max working pressure (bar)	10
Temperature °C	-5 ÷ +50
Flow rate at 6 bar with Δp=1 (NI/min)	410
Orifice size (mm)	6
Working ports size	G 1/8"

FUNCTION	
31	= Closed centres
32	= Open centres
33	= Pressured centres

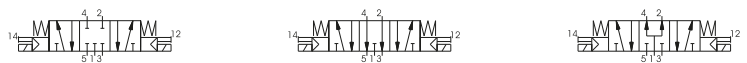

1  
AIR DISTRIBUTION

**Solenoid - Spring**

Coding: 488.0.0.1.S

**Operational characteristics**

Fluid	Filtered air. No lubrication needed, if applied it shall be continuous
Max working pressure (bar)	10
Temperature °C	-5 ÷ +50
Flow rate at 6 bar with Δp=1 (Nl/min)	620
Orifice size (mm)	6
Working ports size	G 1/8"
Response time according to ISO 12238, activation time (ms)	20,3 (3 ways) 22,5 (5 ways)
Response time according to ISO 12238, deactivation time (ms)	44,5 (3 ways) 47,0 (5 ways)

TYPE	32 = 3 ways 52 = 5 ways
------	----------------------------

SOLENOID	M11 = 24V D.C. (rating power 3,8W) M56 = 24V 50/60Hz (starting power 9VA, rating power 6VA) M57 = 110 V 50/60Hz (starting power 9 A, rating power 6 A) M58 = 230V 50/60Hz (starting power 9VA, rating power 6VA)
----------	---

*Shifting time of pneumatic directional control valves or moving parts, logic devices were measured in accordance to ISO 12238:2001*

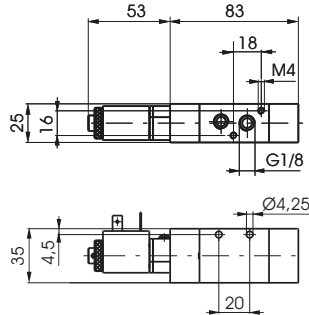

Weight 220 g  
Minimum working pressure 2,5 bar

488.32.0.1.S

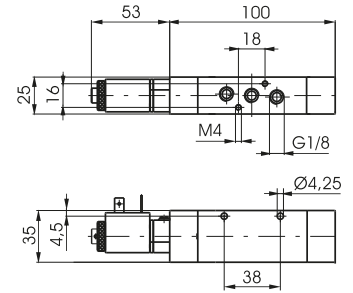
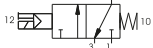

Weight 260 g  
Minimum working pressure 2,5 bar

488.52.0.1.S



**Solenoid - Differential**

Coding: 488.0.0.12.S

**Operational characteristics**

Fluid	Filtered air. No lubrication needed, if applied it shall be continuous
Max working pressure (bar)	10
Temperature °C	-5 ÷ +50
Flow rate at 6 bar with Δp=1 (Nl/min)	620
Orifice size (mm)	6
Working ports size	G 1/8"
Response time according to ISO 12238, activation time (ms)	28,0 (3 ways) 28,3 (5 ways)
Response time according to ISO 12238, deactivation time (ms)	34,5 (3 ways) 35,5 (5 ways)

TYPE	32 = 3 ways 52 = 5 ways
------	----------------------------

SOLENOID	M11 = 24V D.C. (rating power 3,8W) M56 = 24V 50/60Hz (starting power 9VA, rating power 6VA) M57 = 110 V 50/60Hz (starting power 9 A, rating power 6 A) M58 = 230V 50/60Hz (starting power 9VA, rating power 6VA)
----------	---

*Shifting time of pneumatic directional control valves or moving parts, logic devices were measured in accordance to ISO 12238:2001*

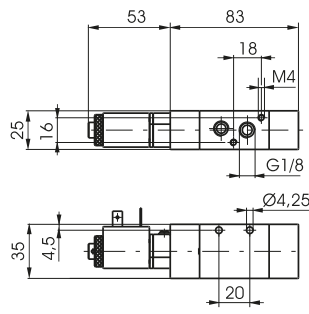

Weight 220 g  
Minimum working pressure 2,5 bar

488.32.0.12.S

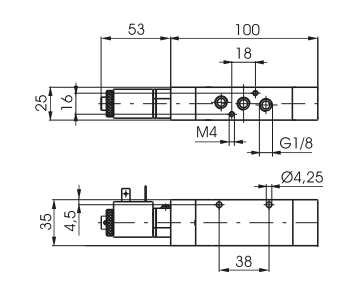

Weight 260 g  
Minimum working pressure 2,5 bar

488.52.0.12.S



**Solenoid - Solenoid**

Coding: 488.0.0.0.S

**Operational characteristics**

Fluid	Filtered air. No lubrication needed, if applied it shall be continuous
Max working pressure (bar)	10
Temperature °C	-5 ÷ +50
Flow rate at 6 bar with Δp=1 (Nl/min)	410
Orifice size (mm)	6
Working ports size	G 1/8"
Response time according to ISO 12238, activation time (ms)	19,0 (3 ways) 18,2 (5 ways)
Response time according to ISO 12238, deactivation time (ms)	21,1 (3 ways) 18,5 (5 ways)

TYPE	32 = 3 ways 52 = 5 ways
------	----------------------------

SOLENOID	M11 = 24V D.C. (rating power 3,8W) M56 = 24V 50/60Hz (starting power 9VA, rating power 6VA) M57 = 110 V 50/60Hz (starting power 9 A, rating power 6 A) M58 = 230V 50/60Hz (starting power 9VA, rating power 6VA)
----------	---

*Shifting time of pneumatic directional control valves or moving parts, logic devices were measured in accordance to ISO 12238:2001*

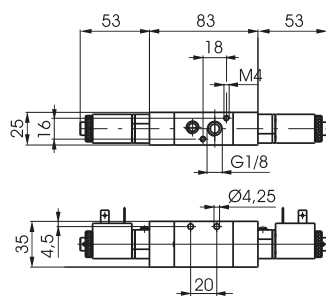

Weight 320 g  
Minimum working pressure 2 bar

488.32.0.0.S

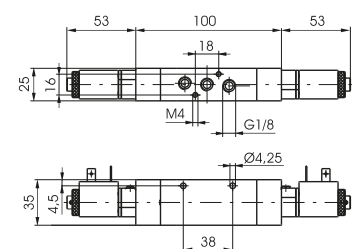

Weight 360 g  
Minimum working pressure 2 bar

488.52.0.0.S



**Solenoid - Solenoid 5 ways 3 connections**

Coding: 488.53.Ⓡ.0.0.Ⓢ

Operational characteristics	
Fluid	Filtered air. No lubrication needed, if applied it shall be continuous
Max working pressure (bar)	10
Temperature °C	-5 ÷ +50
Flow rate at 6 bar with Δp=1 (NI/min)	410
Orifice size (mm)	6
Working ports size	G 1/8"
Response time according to ISO 12238, activation time (ms)	23,0 (closed centres) 21,5 (open centres) 18,9 (pressured centres)
Response time according to ISO 12238, deactivation time (ms)	41,0 (closed centres) 38,0 (open centres) 40,2 (pressured centres)

FUNCTION		SOLENOID	
Ⓡ	31 = Closed centres	M11 =	24V D.C. (rating power 3,8W)
	32 = Open centres	M56 =	24V 50/60Hz (starting power 9VA, rating power 6VA)
	33 = Pressured centres	M57 =	110 V 50/60Hz (starting power 9 A, rating power 6 A)
Ⓢ		M58 =	230V 50/60Hz (starting power 9VA, rating power 6VA)

Shifting time of pneumatic directional control valves or moving parts, logic devices were measured in accordance to ISO 12238:2001



Weight 400 g  
Minimum working pressure 3 bar

488.53.31.0.0.Ⓢ

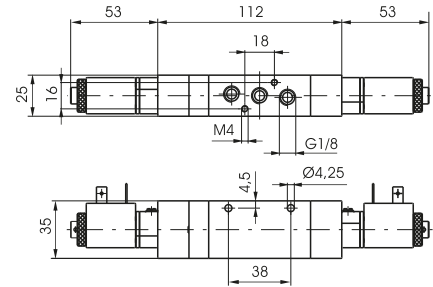
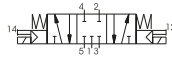

Weight 400 g  
Minimum working pressure 3 bar

488.53.32.0.0.Ⓢ

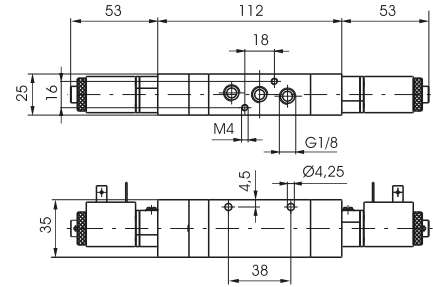

Weight 400 g  
Minimum working pressure 3 bar

488.53.33.0.0.Ⓢ

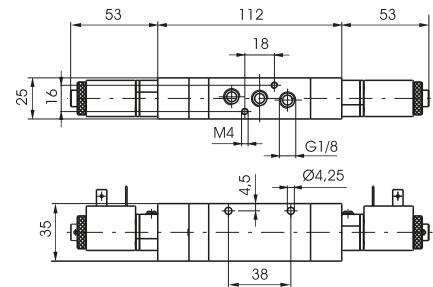
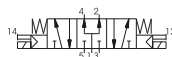

1

AIR DISTRIBUTION

Collectors

Coding: 488.P



N. POSITIONS	
02	= 2 positions (220 g)
03	= 3 positions (290 g)
04	= 4 positions (360 g)
05	= 5 positions (430 g)
06	= 6 positions (500 g)
07	= 7 positions (570 g)
08	= 8 positions (640 g)
09	= 9 positions (710 g)
10	= 10 positions (780 g)

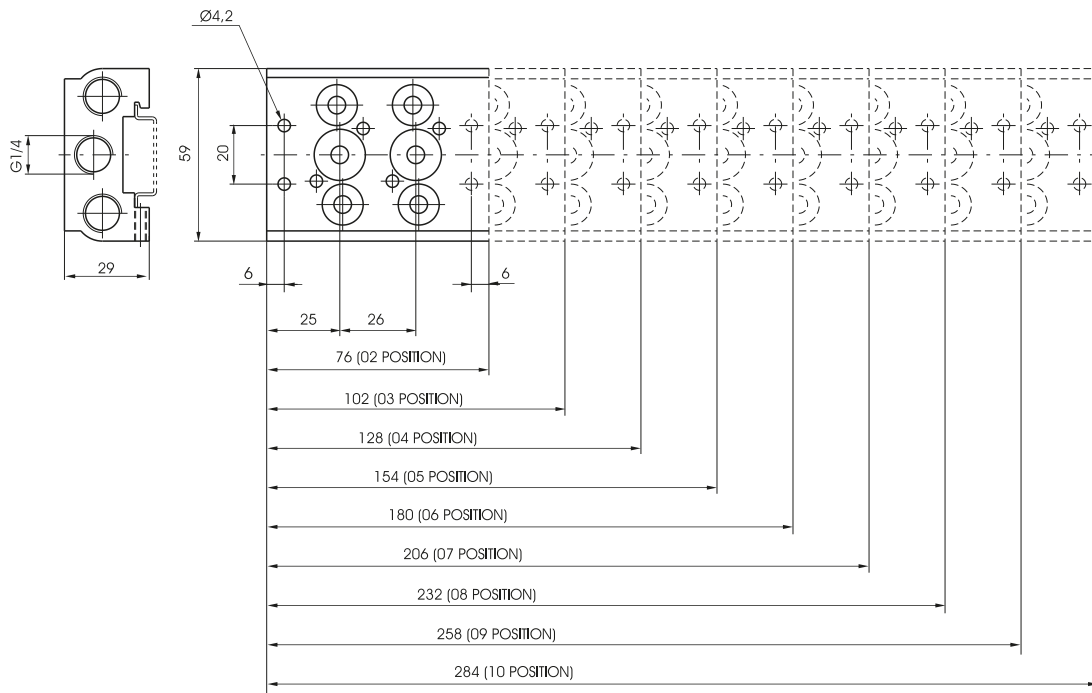

Closing plate

Coding: 488.00

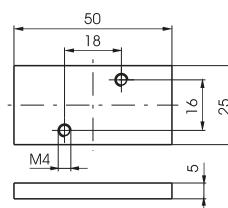

Weight 25 g

1 AIR DISTRIBUTION

**Solenoid - Spring**

Coding: 464.Ⓡ.0.1.M2

Operational characteristics	
Fluid	Filtered air. No lubrication needed, if applied it shall be continuous
Max working pressure (bar)	10
Temperature °C	-5 ÷ +50
Flow rate at 6 bar with Δp=1 (NI/min)	1360
Orifice size (mm)	8
Working ports size	G 1/4"

TYPE	
Ⓡ	32 = 3 ways
	52 = 5 ways

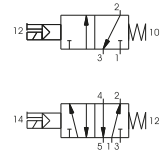

3 ways

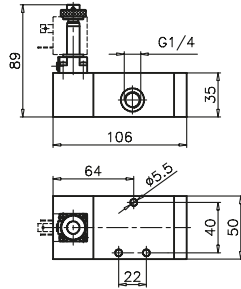

Weight 530 g  
Minimum working pressure 2,5 bar

464.32.0.1.M2

5 ways

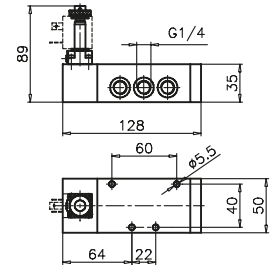

Weight 625 g  
Minimum working pressure 2,5 bar

464.52.0.1.M2

**Solenoid - Differential**

Coding: 464.Ⓡ.0.12.M2

Operational characteristics	
Fluid	Filtered air. No lubrication needed, if applied it shall be continuous
Max working pressure (bar)	10
Temperature °C	-5 ÷ +50
Flow rate at 6 bar with Δp=1 (NI/min)	1360
Orifice size (mm)	8
Working ports size	G 1/4"

TYPE	
Ⓡ	32 = 3 ways
	52 = 5 ways

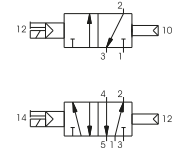

3 ways

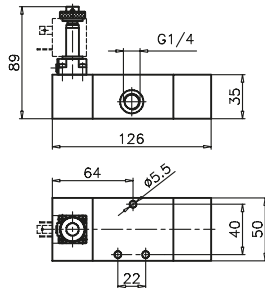

Weight 650 g  
Minimum working pressure 2,5 bar

464.32.0.12.M2

5 ways

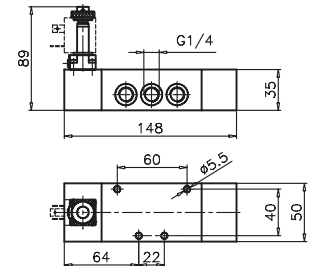

Weight 740 g  
Minimum working pressure 2,5 bar

464.52.0.12.M2

**Solenoid - Solenoid**

Coding: 464.Ⓡ.0.0.M2

Operational characteristics	
Fluid	Filtered air. No lubrication needed, if applied it shall be continuous
Max working pressure (bar)	10
Temperature °C	-5 ÷ +50
Flow rate at 6 bar with Δp=1 (NI/min)	1360
Orifice size (mm)	8
Working ports size	G 1/4"

TYPE	
Ⓡ	32 = 3 ways
	52 = 5 ways

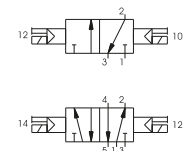

3 ways

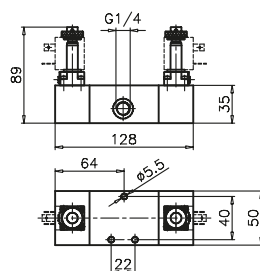

Weight 730 g  
Minimum working pressure 2 bar

464.32.0.0.M2

5 ways 2 connections

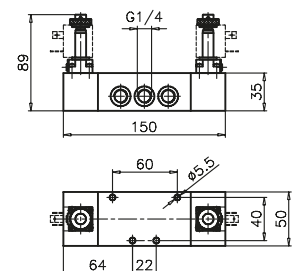

Weight 820 g  
Minimum working pressure 2 bar

464.52.0.0.M2

**Solenoid - Solenoid 5 ways 3 connections**

Coding: 464.53.F.0.0.M2

**Operational characteristics**

Fluid	Filtered air. No lubrication needed, if applied it shall be continuous
Max working pressure (bar)	10
Temperature °C	-5 ÷ +50
Flow rate at 6 bar with Δp=1 (NI/min)	1280
Orifice size (mm)	8
Working ports size	G 1/4"

FUNCTION	
F	31 = Closed centres
	32 = Open centres
	33 = Pressured centres

1

AIR DISTRIBUTION

5 ways 3 connections

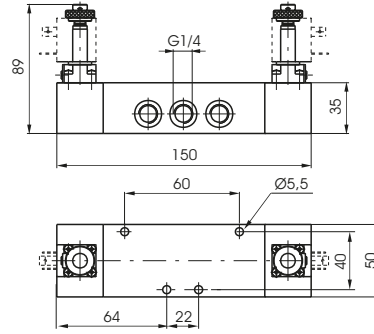

Weight 820 g  
Minimum working pressure 3 bar

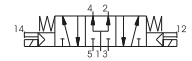
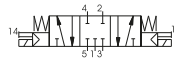

**Solenoid - Spring**

Coding: 464/1.1.0.1.M2

Operational characteristics	
Fluid	Filtered air. No lubrication needed, if applied it shall be continuous
Max working pressure (bar)	10
Temperature °C	-5 ÷ +50
Flow rate at 6 bar with Δp=1 (NI/min)	1360
Orifice size (mm)	8
Working ports size	G 1/4"

TYPE	
32 = 3 ways	
52 = 5 ways	

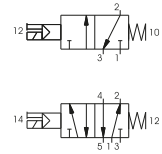

3 ways

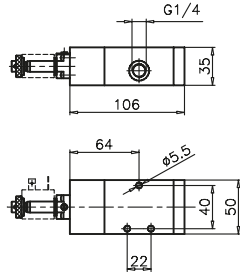

Weight 530 g  
Minimum working pressure 2,5 bar

464/1.32.0.1.M2

5 ways

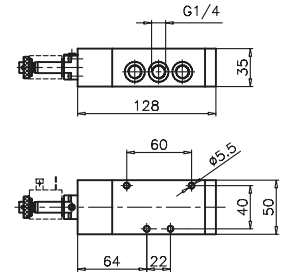

Weight 625 g  
Minimum working pressure 2,5 bar

464/1.52.0.1.M2

**Solenoid - Differential**

Coding: 464/1.1.0.12.M2

Operational characteristics	
Fluid	Filtered air. No lubrication needed, if applied it shall be continuous
Max working pressure (bar)	10
Temperature °C	-5 ÷ +50
Flow rate at 6 bar with Δp=1 (NI/min)	1360
Orifice size (mm)	8
Working ports size	G 1/4"

TYPE	
32 = 3 ways	
52 = 5 ways	

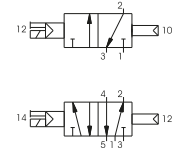

3 ways

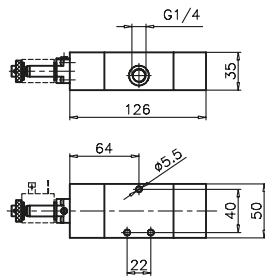

Weight 650 g  
Minimum working pressure 2,5 bar

464/1.32.0.12.M2

5 ways

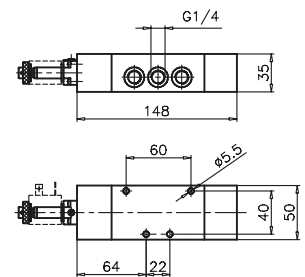

Weight 740 g  
Minimum working pressure 2,5 bar

464/1.52.0.12.M2

**Solenoid - Solenoid**

Coding: 464/1.1.0.0.M2

Operational characteristics	
Fluid	Filtered air. No lubrication needed, if applied it shall be continuous
Max working pressure (bar)	10
Temperature °C	-5 ÷ +50
Flow rate at 6 bar with Δp=1 (NI/min)	1360
Orifice size (mm)	8
Working ports size	G 1/4"

TYPE	
32 = 3 ways	
52 = 5 ways	

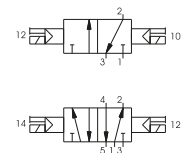

3 ways

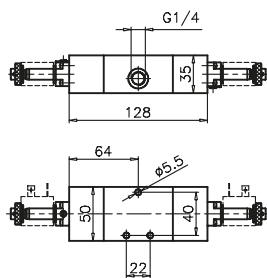

Weight 730 g  
Minimum working pressure 2 bar

464/1.32.0.0.M2

5 ways 2 connections

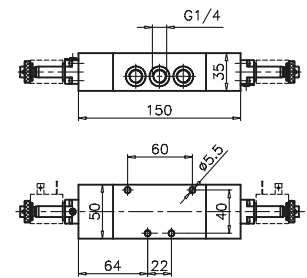

Weight 820 g  
Minimum working pressure 2 bar

464/1.52.0.0.M2



**Solenoid - Solenoid 5 ways 3 connections**

Coding: 464/1.53.F.0.0.M2

**Operational characteristics**

Fluid	Filtered air. No lubrication needed, if applied it shall be continuous
Max working pressure (bar)	10
Temperature °C	-5 ÷ +50
Flow rate at 6 bar with Δp=1 (Nl/min)	1280
Orifice size (mm)	8
Working ports size	G 1/4"

FUNCTION	
F	31 = Closed centres
	32 = Open centres
	33 = Pressured centres

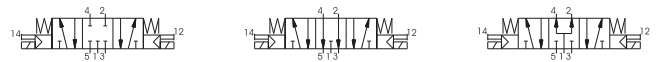
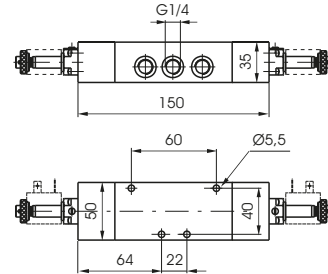

Weight 820 g  
Minimum working pressure 3 bar

1 AIR DISTRIBUTION



**Solenoid - Spring**

Coding: 452.Ⓡ.0.1.M2

Operational characteristics	
Fluid	Filtered air. No lubrication needed, if applied it shall be continuous
Max working pressure (bar)	10
Temperature °C	-5 ÷ +50
Flow rate at 6 bar with Δp=1 (NI/min)	3500
Orifice size (mm)	15
Working ports size	G 1/2"

TYPE	
Ⓡ 32 = 3 ways	
52 = 5 ways	



Weight 1152 g  
Minimum working pressure 2,5 bar

452.32.0.1.M2

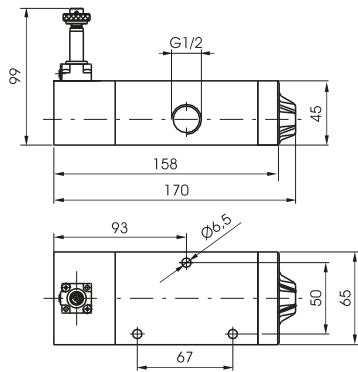

Weight 1422 g  
Minimum working pressure 2,5 bar

452.52.0.1.M2

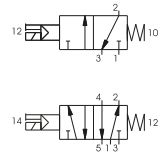
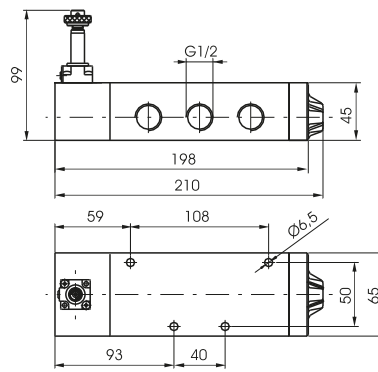

**Solenoid - Differential**

Coding: 452.Ⓡ.0.12.M2

Operational characteristics	
Fluid	Filtered air. No lubrication needed, if applied it shall be continuous
Max working pressure (bar)	10
Temperature °C	-5 ÷ +50
Flow rate at 6 bar with Δp=1 (NI/min)	3500
Orifice size (mm)	15
Working ports size	G 1/2"

TYPE	
Ⓡ 32 = 3 ways	
52 = 5 ways	



Weight 1422 g  
Minimum working pressure 2,5 bar

452.32.0.12.M2

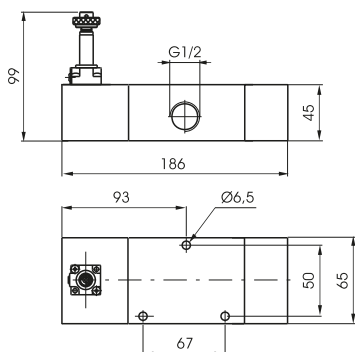

Weight 1692 g  
Minimum working pressure 2 bar

452.52.0.12.M2

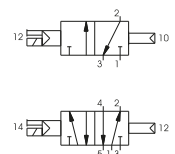
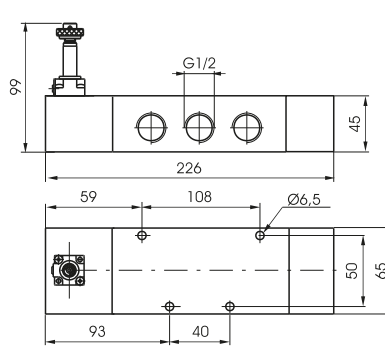



Solenoid - Solenoid

Coding: 452.0.0.M2

Operational characteristics

Fluid	Filtered air. No lubrication needed, if applied it shall be continuous
Max working pressure (bar)	10
Temperature °C	-5 ÷ +50
Flow rate at 6 bar with Δp=1 (NI/min)	3500
Orifice size (mm)	15
Working ports size	G 1/2"

TYPE
32 = 3 ways
52 = 5 ways



Weight 1474 g  
Minimum working pressure 2 bar

452.32.0.0.M2



Weight 1744 g  
Minimum working pressure 2 bar

452.52.0.0.M2

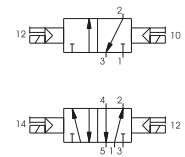
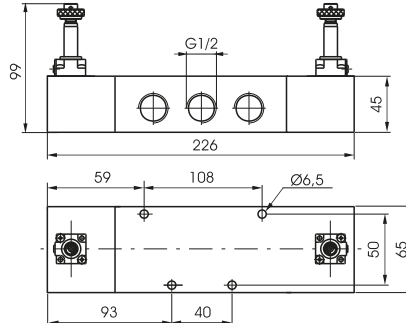
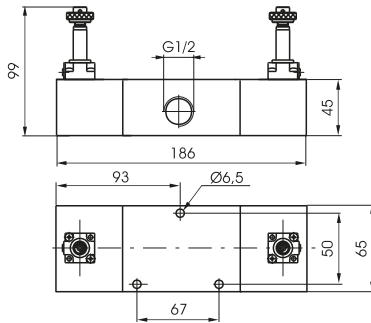

Solenoid - Solenoid 5 ways 3 connections

Coding: 452.53.0.0.M2

Operational characteristics

Fluid	Filtered air. No lubrication needed, if applied it shall be continuous
Max working pressure (bar)	10
Temperature °C	-5 ÷ +50
Flow rate at 6 bar with Δp=1 (NI/min)	3500
Orifice size (mm)	15
Working ports size	G 1/2"

FUNCTION
31 = Closed centres
32 = Open centres
33 = Pressured centres



Weight 1744 g  
Minimum working pressure 3 bar

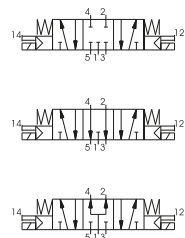
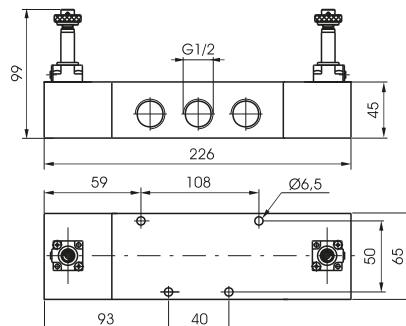

AIR DISTRIBUTION

1

**Solenoid - Spring**

Coding: 452/1.1.0.1.M2

Operational characteristics	
Fluid	Filtered air. No lubrication needed, if applied it shall be continuous
Max working pressure (bar)	10
Temperature °C	-5 ÷ +50
Flow rate at 6 bar with Δp=1 (NI/min)	3500
Orifice size (mm)	15
Working ports size	G 1/2"

TYPE	
1 32 = 3 ways	
52 = 5 ways	



Weight 1330 g  
Minimum working pressure 2,5 bar

452/1.32.0.1.M2



Weight 1600 g  
Minimum working pressure 2,5 bar

452/1.52.0.1.M2

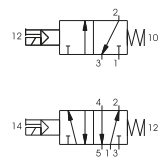
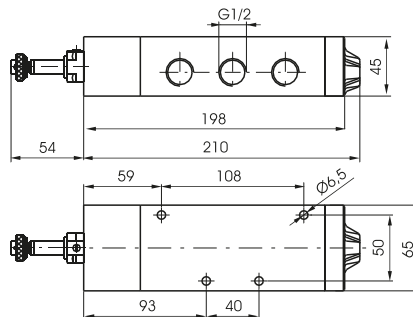
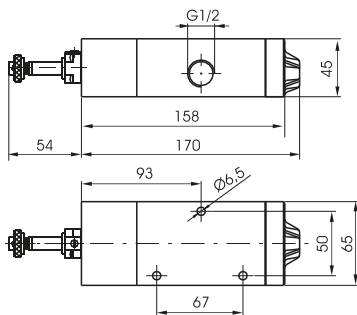

**Solenoid - Differential**

Coding: 452/1.1.0.12.M2

Operational characteristics	
Fluid	Filtered air. No lubrication needed, if applied it shall be continuous
Max working pressure (bar)	10
Temperature °C	-5 ÷ +50
Flow rate at 6 bar with Δp=1 (NI/min)	3500
Orifice size (mm)	15
Working ports size	G 1/2"

TYPE	
1 32 = 3 ways	
52 = 5 ways	



Weight 1600 g  
Minimum working pressure 2,5 bar

452/1.32.0.12.M2



Weight 1870 g  
Minimum working pressure 2 bar

452/1.52.0.12.M2

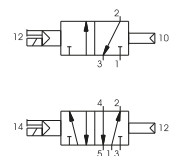
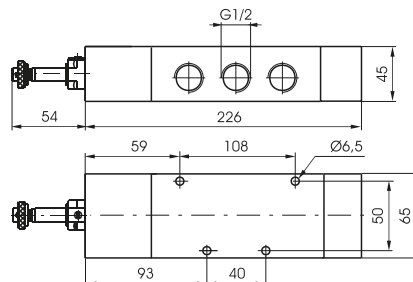
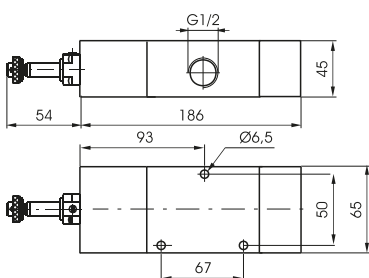

**Solenoid - Solenoid**

Coding: 452/1.0.0.M2

Operational characteristics	
Fluid	Filtered air. No lubrication needed, if applied it shall be continuous
Max working pressure (bar)	10
Temperature °C	-5 ÷ +50
Flow rate at 6 bar with Δp=1 (NI/min)	3500
Orifice size (mm)	15
Working ports size	G 1/2"

TYPE	
<b>T</b>	32 = 3 ways
	52 = 5 ways



Weight 1830 g  
Minimum working pressure 2 bar

452/1.32.0.0.M2

Weight 2100 g  
Minimum working pressure 2 bar

452/1.52.0.0.M2

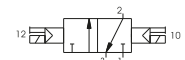
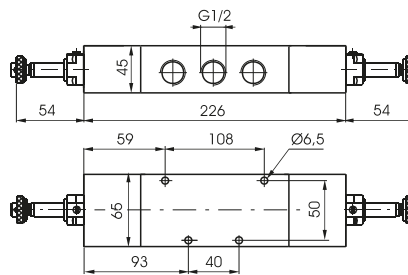
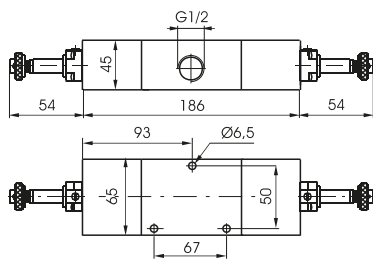

**Solenoid - Solenoid 5 ways 3 connections**

Coding: 452/1.53.0.0.M2

Operational characteristics	
Fluid	Filtered air. No lubrication needed, if applied it shall be continuous
Max working pressure (bar)	10
Temperature °C	-5 ÷ +50
Flow rate at 6 bar with Δp=1 (NI/min)	3500
Orifice size (mm)	15
Working ports size	G 1/2"

FUNCTION	
<b>F</b>	31 = Closed centres
	32 = Open centres
	33 = Pressured centres



Weight 2100 g  
Minimum working pressure 3 bar

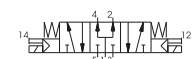
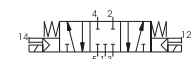
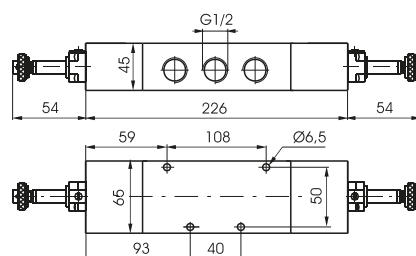

AIR DISTRIBUTION

1

**Solenoid - Spring**

Coding: 412/2.1.0.1.F.M2

Operational characteristics	
Fluid	Filtered air. No lubrication needed, if applied it shall be continuous
Max working pressure (bar)	10
Temperature °C	-5 ÷ +50
Flow rate at 6 bar with Δp=1 (NI/min)	3600
Orifice size (mm)	15
Working ports size	G 1/2"

TYPE	
T	32 = 3 ways 52 = 5 ways
FUNCTION (only for 3 ways)	
F	C = Normally Closed A = Normally Open

3 ways

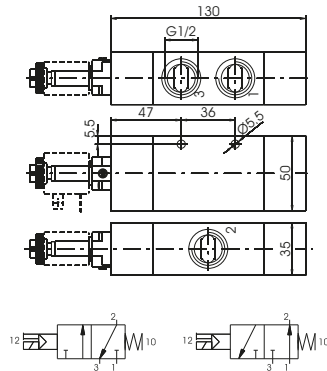

Weight 578 g  
Minimum working pressure 2,5 bar  
412/2.32.0.1.F.M2

5 ways

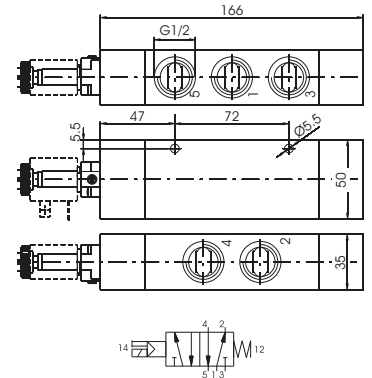

Weight 700 g  
Minimum working pressure 2,5 bar  
412/2.52.0.1.F.M2

1  
AIR DISTRIBUTION

**Solenoid - Differential external**

Coding: 412/2.1.0.12.F.M2

Operational characteristics	
Fluid	Filtered air. No lubrication needed, if applied it shall be continuous
Max working pressure (bar)	10
Temperature °C	-5 ÷ +50
Flow rate at 6 bar with Δp=1 (NI/min)	3600
Orifice size (mm)	15
Working ports size	G 1/2"

TYPE	
T	32 = 3 ways 52 = 5 ways
FUNCTION (only for 3 ways)	
F	C = Normally Closed A = Normally Open

3 ways

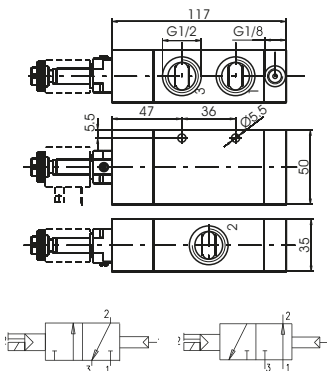

Weight 522 g  
Minimum working pressure 2,5 bar  
412/2.32.0.12.F.M2

5 ways

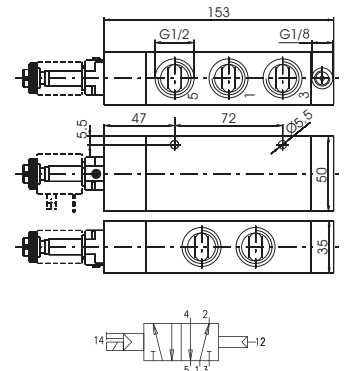

Weight 644 g  
Minimum working pressure 2,5 bar  
412/2.52.0.12.F.M2

**Pneumatic - Differential self aligned**

Coding: 412/2.1.0.12/1.F.M2

Operational characteristics	
Fluid	Filtered air. No lubrication needed, if applied it shall be continuous
Max working pressure (bar)	10
Temperature °C	-5 ÷ +50
Flow rate at 6 bar with Δp=1 (NI/min)	3600
Orifice size (mm)	15
Working ports size	G 1/2"

TYPE	
T	32 = 3 ways 52 = 5 ways
FUNCTION (only for 3 ways)	
F	C = Normally Closed A = Normally Open

3 ways

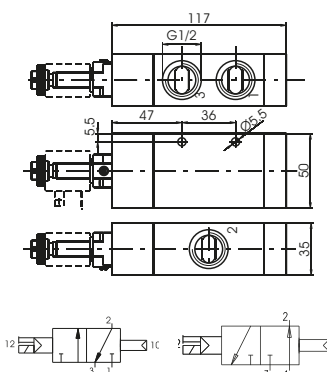

Weight 526 g  
Minimum working pressure 2,5 bar  
412/2.32.0.12/1.F.M2

5 ways

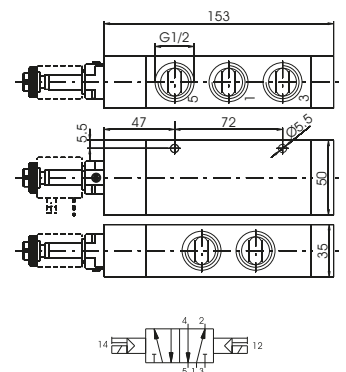

Weight 648 g  
Minimum working pressure 2,5 bar  
412/2.52.0.12/1.F.M2

**Solenoid - Solenoid**

Coding: 412/2.Ⓡ.0.0.M2

**Operational characteristics**

Fluid	Filtered air. No lubrication needed, if applied it shall be continuous
Max working pressure (bar)	10
Temperature °C	-5 ÷ +50
Flow rate at 6 bar with Δp=1 (Nl/min)	3600
Orifice size (mm)	15
Working ports size	G 1/2"

TYPE
Ⓡ = 3 ways
Ⓜ = 5 ways

AIR DISTRIBUTION

3 ways

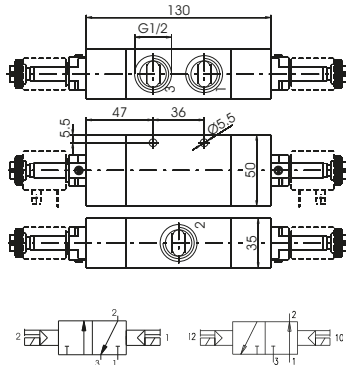

Weight 612 g  
Minimum working pressure 2 bar  
412/2.32.0.0.M2

5 ways 2 connections

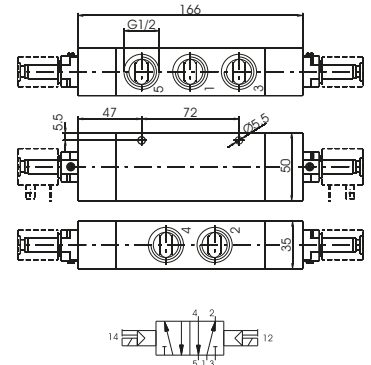

Weight 732 g  
Minimum working pressure 2 bar  
412/2.52.0.0.M2

**Solenoid - Solenoid 5 ways 3 connections**

Coding: 412/2.53.Ⓡ.0.0.M2

**Operational characteristics**

Fluid	Filtered air. No lubrication needed, if applied it shall be continuous
Max working pressure (bar)	10
Temperature °C	-5 ÷ +50
Flow rate at 6 bar with Δp=1 (Nl/min)	3300
Orifice size (mm)	15
Working ports size	G 1/2"

FUNCTION
Ⓡ = Closed centres
Ⓜ = Open centres
Ⓢ = Pressured centres

5 ways 3 connections

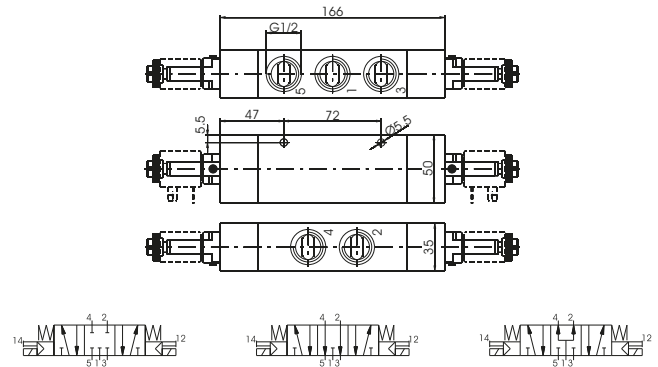

Weight 794 g  
Minimum working pressure 3 bar

**Solenoid - Spring**

Coding: 411. **T**.0.1. **S**

Operational characteristics	
Fluid	Filtered air. No lubrication needed, if applied it shall be continuous
Max working pressure (bar)	10
Temperature °C	-5 ÷ +50
Flow rate at 6 bar with $\Delta p=1$ (l/min)	6500
Orifice size (mm)	20
Working ports size	G 1"

<b>T</b>	TYPE 32 = 3 ways 52 = 5 ways
<b>S</b>	SOLENOID SEE SOLENOID VALVES "S" TYPE, SERIES 300

3 ways

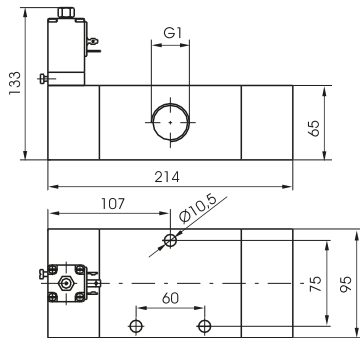

Weight 3400 g  
Minimum working pressure 2,5 bar

411.32.0.1. **S**

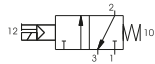

5 ways

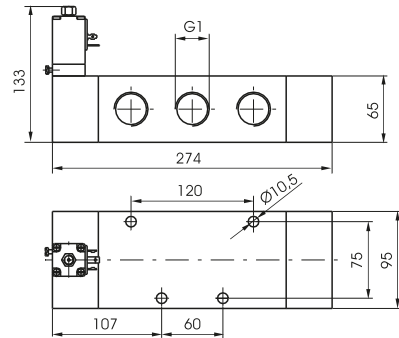

Weight 4300 g  
Minimum working pressure 2,5 bar

411.52.0.1. **S**



**Solenoid - Differential**

Coding: 411. **T**.0.12. **S**

Operational characteristics	
Fluid	Filtered air. No lubrication needed, if applied it shall be continuous
Max working pressure (bar)	10
Temperature °C	-5 ÷ +50
Flow rate at 6 bar with $\Delta p=1$ (l/min)	6500
Orifice size (mm)	20
Working ports size	G 1"

<b>T</b>	TYPE 32 = 3 ways 52 = 5 ways
<b>S</b>	SOLENOID SEE SOLENOID VALVES "S" TYPE, SERIES 300

3 ways

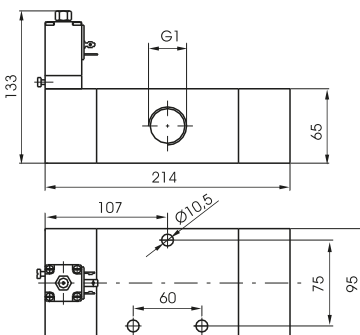

Weight 3400 g  
Minimum working pressure 2,5 bar

411.32.0.12. **S**

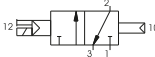

5 ways

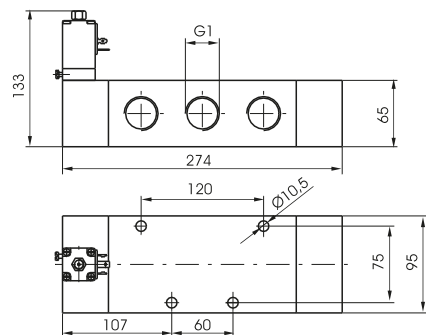

Weight 4300 g  
Minimum working pressure 2,5 bar

411.52.0.12. **S**



1  
AIR DISTRIBUTION

**Solenoid - Solenoid**

Coding: 411.1.0.0.S

**Operational characteristics**

Fluid	Filtered air. No lubrication needed, if applied it shall be continuous
Max working pressure (bar)	10
Temperature °C	-5 ÷ +50
Flow rate at 6 bar with Δp=1 (NI/min)	6500
Orifice size (mm)	20
Working ports size	G1"

TYPE	
1	32 = 3 ways
	52 = 5 ways
SOLENOID	
S	SEE SOLENOID VALVES "S" TYPE, SERIES 300

AIR DISTRIBUTION

3 ways

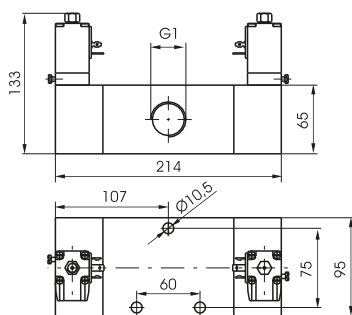

Weight 3700 g  
Minimum working pressure 2 bar

411.32.0.0.S

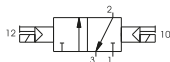

5 ways 2 connections

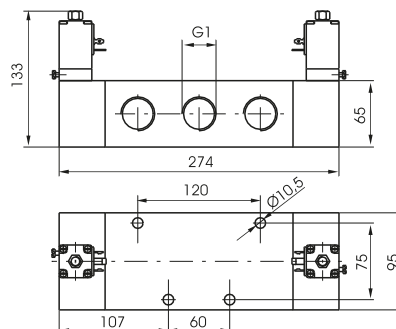

Weight 4600 g  
Minimum working pressure 2 bar

411.52.0.0.S

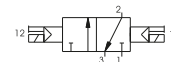

**Solenoid - Solenoid 5 ways 3 connections**

Coding: 411.53.F.0.0.S

**Operational characteristics**

Fluid	Filtered air. No lubrication needed, if applied it shall be continuous
Max working pressure (bar)	10
Temperature °C	-5 ÷ +50
Flow rate at 6 bar with Δp=1 (NI/min)	6500
Orifice size (mm)	20
Working ports size	G1"

FUNCTION	
F	31 = Closed centres
	32 = Open centres
	33 = Pressured centres
SOLENOID	
S	SEE SOLENOID VALVES "S" TYPE, SERIES 300

5 ways 3 connections

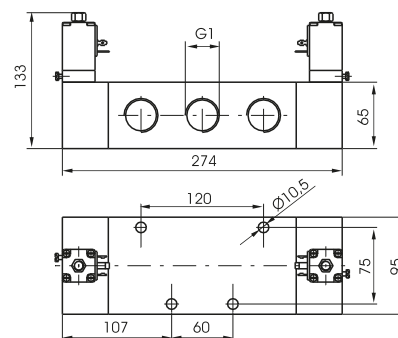

Weight 4700 g  
Minimum working pressure 3 bar







## Series T400

### General

The Series **T400** involves a wide range of valves and solenoid valves, with several type of acting, with connections from **G1/8" (T488)** and **G1/4" (T424)**, are manufactured with high performance technopolymer.

The use of technopolymer has resulted in a light weight product which can be offered to the market at very interesting prices.

The gang mounted solenoid valves are available with the traditional manifold obtained from bored square bar of series 600 and with the extruded aluminium base allowing a unic inlet port conveying the exhausts. The base is also prearranged to be fixed on DIN 46277/3 guide.

The Valves and Solenoid valves **G1/8" (T488)** are: 5 ways function, pneumatically operated, single solenoid (monostable) mechanical or pneumatic spring return, spring or pneumatic return, with 2 coils (bistable) and in 5 ways 3 positions version with closed, open and pressured centres.

The solenoid valves are supplied complete with coil (see Series 300) so that the tension has to be added to the solenoid valve code:

- M9** = Coil 24 V D.C. (rating power 2 watt)
- M11** = Coil 24 V D.C. (rating power 3.8 watt)
- M56** = Coil 24 V 50/60 HZ (starting power 9 VA, rating power 6 VA)
- M57** = Coil 110 V 50/60 HZ (starting power 9 VA, rating power 6 VA)
- M58** = Coil 220 V 50/60 HZ (starting power 9 VA, rating power 6 VA)

The Solenoid valves series **G1/4" (T424)**, are manufactured, depending on version and actuation (manual, pneumatic, or electrical), and self aligning (pneumatic - electric or spring) 3/2, 5/2 and 5/3 ways function, (monostable), (bistable).

The solenoid valves are supplied complete with coil so that the tension has to be added to the solenoid valve code.

- B04** = coil 12V D.C.
- B05** = coil 24V D.C.
- B09** = coil 24V (2W) D.C.
- B56** = coil 24V 50/60 Hz A.C.
- B57** = coil 110V 50/60 Hz A.C.
- B58** = coil 220V 50/60 Hz A.C.

1  
AIR DISTRIBUTION

### Construction characteristics

Body	Technopolymer
Spacer	Technopolymer
Spacers	NBR
Piston seals	NBR
Springs	AISI 302 stainless steel
Operators	Technopolymer
Pistons	Technopolymer
Spools	Nickel - plated steel / Technopolymer

### Maximum fitting torque

Thread	Maximum torque (Nm)
G 1/8"	4
G1/4"	9

### Use and maintenance

This valves have an average life of 15 million cycles depending on the application and air quality.

Filtered and lubricated air using specified lubricants will reduce the wear of the seals and ensures long and trouble free operation.

Please ensure that the valve is being used according with the manufacturers specification, such as air pressure and temperature.

The exhaust port of the distributor has to be protected in a dusty and dirty environment.

Repair kits including the spool complete with seals are available for overhauling the valves.

However, although this is a simple operation it should be carried out by a competent person.

**ATTENTION:** use hydraulic oil class H for lubrication such as MAGNA GC 32 (Castrol).

**Pneumatic - Spring**

Coding: T488.1.11.1

**Operational characteristics**

Fluid	Filtered air. No lubrication needed, if applied it shall be continuous
Max working pressure (bar)	10
Temperature °C	-5 ÷ +50
Flow rate at 6 bar with Δp=1 (NI/min)	620
Orifice size (mm)	6
Working ports size	G 1/8"

TYPE	
① 32 = 3 ways	
52 = 5 ways	

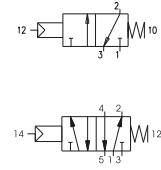

AIR DISTRIBUTION 1

3 ways



Weight 75 g  
Minimum working pressure 2,5 bar

T488.32.11.1

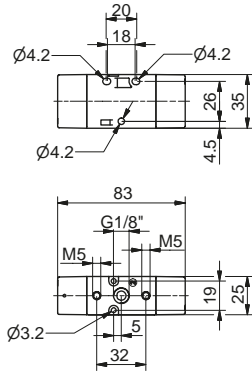

5 ways



Weight 75 g  
Minimum working pressure 2,5 bar

T488.52.11.1

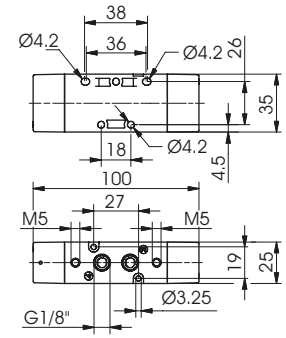

**Pneumatic - Differential (External)**

Coding: T488.1.11.12

**Operational characteristics**

Fluid	Filtered air. No lubrication needed, if applied it shall be continuous
Max working pressure (bar)	10
Temperature °C	-5 ÷ +50
Flow rate at 6 bar with Δp=1 (NI/min)	620
Orifice size (mm)	6
Working ports size	G 1/8"

TYPE	
① 32 = 3 ways	
52 = 5 ways	

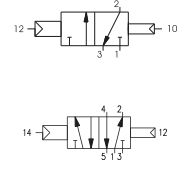

3 ways



T488.32.11.12

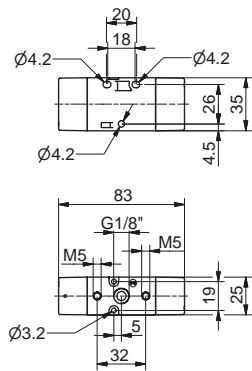

5 ways



T488.52.11.12

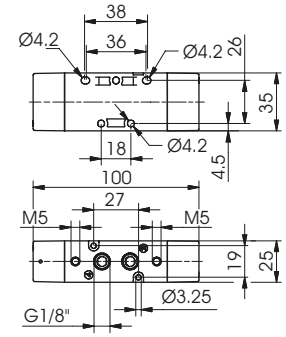

**Pneumatic - Pneumatic**

Coding: T488.1.11.11

**Operational characteristics**

Fluid	Filtered air. No lubrication needed, if applied it shall be continuous
Max working pressure (bar)	10
Temperature °C	-5 ÷ +50
Flow rate at 6 bar with Δp=1 (NI/min)	620
Orifice size (mm)	6
Working ports size	G 1/8"

TYPE	
① 32 = 3 ways	
52 = 5 ways	

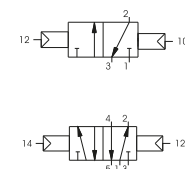

3 ways



Minimum working pressure 2 bar (for Pneumatic-Pneumatic version)

T488.32.11.11

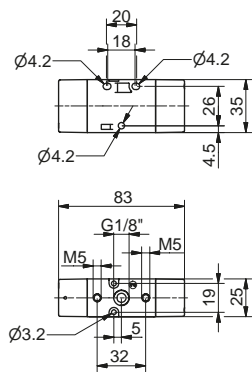

5 ways



Minimum working pressure 2 bar (for Pneumatic-Pneumatic version)

T488.52.11.11

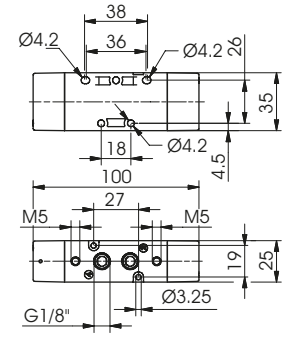

**Pneumatic - Pneumatic 5 ways 3 connections**

Coding: T488.53.F.11.11

Operational characteristics	
Fluid	Filtered air. No lubrication needed, if applied it shall be continuous
Max working pressure (bar)	10
Temperature °C	-5 ÷ +50
Flow rate at 6 bar with $\Delta p=1$ (l/min)	410
Orifice size (mm)	6
Working ports size	G 1/8"

FUNCTION	
<b>F</b>	31 = Closed centres
	32 = Open centres
	33 = Pressured centres

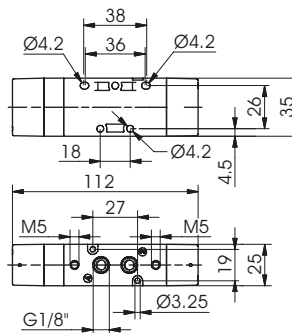

Weight 140 g  
Minimum working pressure 3 bar (for Pneumatic-Pneumatic version)

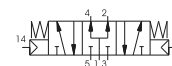
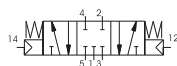

1  
AIR DISTRIBUTION

**Solenoid - Spring (Self-feeding)**

Coding: T488.Ⓡ.0.1.Ⓟ

Operational characteristics	
Fluid	Filtered air. No lubrication needed, if applied it shall be continuous
Max working pressure (bar)	10
Temperature °C	-5 ÷ +50
Flow rate at 6 bar with Δp=1 (NI/min)	620
Orifice size (mm)	6
Working ports size	G 1/8"
Response time according to ISO 12238, activation time (ms)	23,4 (3 ways) 22,8 (5 ways)
Response time according to ISO 12238, deactivation time (ms)	41,0 (3 ways) 44,5 (5 ways)

*Shifting time of pneumatic directional control valves or moving parts, logic devices were measured in accordance to ISO 12238:2001*

TYPE	
Ⓡ	32 = 3 ways
	52 = 5 ways
VOLTAGE	
M9	= Solenoid - Spring (Self-feeding)
M11	= 24V D.C. (rating power 3,8W)
Ⓟ	M56 = 24V 50/60Hz (starting power 9VA, rating power 6VA)
	M57 = 110V 50/60Hz (starting power 9VA, rating power 6VA)
	M58 = 230V 50/60Hz (starting power 9VA, rating power 6VA)



Weight 160 g  
Minimum working pressure 2,5 bar

Weight 190 g  
Minimum working pressure 2,5 bar

T488.32.0.1.Ⓟ

T488.52.0.1.Ⓟ

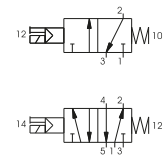
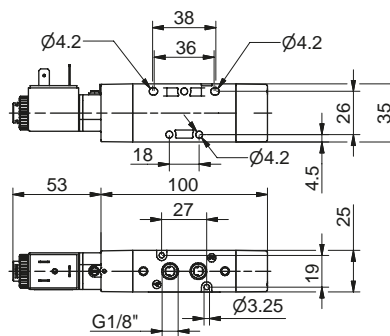
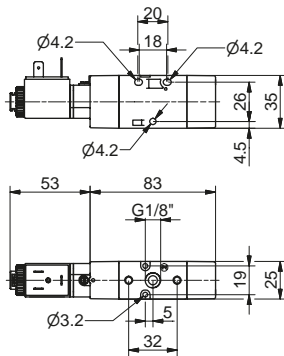

**Solenoid - Spring (External-feeding)**

Coding: T488.Ⓡ.0.1.E.Ⓟ

Operational characteristics	
Fluid	Filtered air. No lubrication needed, if applied it shall be continuous
Max working pressure (bar)	10
Temperature °C	-5 ÷ +50
Flow rate at 6 bar with Δp=1 (NI/min)	620
Orifice size (mm)	6
Working ports size	G 1/8"
Response time according to ISO 12238, activation time (ms)	23,4 (3 ways) 22,8 (5 ways)
Response time according to ISO 12238, deactivation time (ms)	41,0 (3 ways) 44,5 (5 ways)

*Shifting time of pneumatic directional control valves or moving parts, logic devices were measured in accordance to ISO 12238:2001*

TYPE	
Ⓡ	32 = 3 ways
	52 = 5 ways
VOLTAGE	
M9	= Solenoid - Spring (Self-feeding)
M11	= 24V D.C. (rating power 3,8W)
Ⓟ	M56 = 24V 50/60Hz (starting power 9VA, rating power 6VA)
	M57 = 110V 50/60Hz (starting power 9VA, rating power 6VA)
	M58 = 230V 50/60Hz (starting power 9VA, rating power 6VA)



Weight 160 g  
Minimum working pressure 2,5 bar

Weight 190 g  
Minimum working pressure 2,5 bar

T488.32.0.1.E.Ⓟ

T488.52.0.1.E.Ⓟ

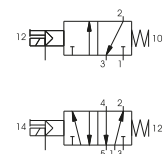
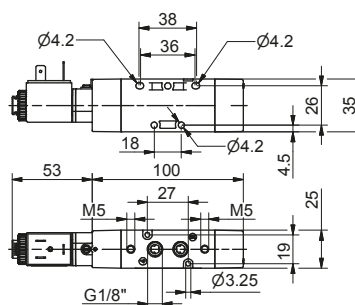
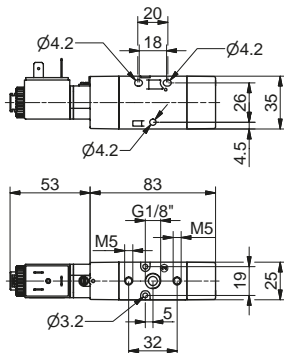

**Solenoid - Differential (Self-feeding)**

Coding: T488.0.12.V

Operational characteristics	
Fluid	Filtered air. No lubrication needed, if applied it shall be continuous
Max working pressure (bar)	10
Temperature °C	-5 ÷ +50
Flow rate at 6 bar with $\Delta p=1$ (NI/min)	620
Orifice size (mm)	6
Working ports size	G 1/8"
Response time according to ISO 12238, activation time (ms)	31,1 (3 ways) 27,9 (5 ways)
Response time according to ISO 12238, deactivation time (ms)	35,0 (3 ways) 34,5 (5 ways)

TYPE	
① 32 = 3 ways	
52 = 5 ways	
VOLTAGE	
M9 = Solenoid - Spring (Self-feeding)	
M11 = 24V D.C. (rating power 3,8W)	
✓ M56 = 24V 50/60Hz (starting power 9VA, rating power 6VA)	
M57 = 110 V 50/60Hz (starting power 9VA, rating power 6VA)	
M58 = 230V 50/60Hz (starting power 9VA, rating power 6VA)	

*Shifting time of pneumatic directional control valves or moving parts, logic devices were measured in accordance to ISO 12238:2001*



Weight 160 g  
Minimum working pressure 2,5 bar

T488.32.0.12.V

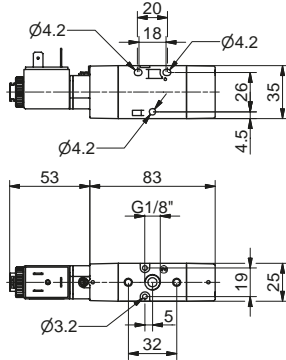

Weight 190 g  
Minimum working pressure 2,5 bar

T488.52.0.12.V

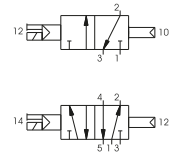
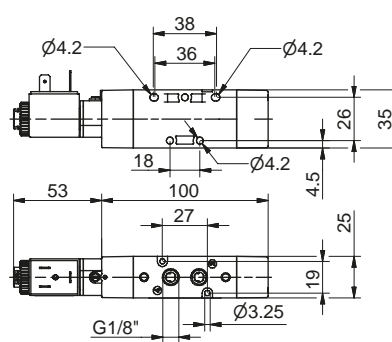

**Solenoid - Differential (External-feeding)**

Coding: T488.0.12E.V

Operational characteristics	
Fluid	Filtered air. No lubrication needed, if applied it shall be continuous
Max working pressure (bar)	10
Temperature °C	-5 ÷ +50
Flow rate at 6 bar with $\Delta p=1$ (NI/min)	620
Orifice size (mm)	6
Working ports size	G 1/8"
Response time according to ISO 12238, activation time (ms)	31,1 (3 ways) 27,9 (5 ways)
Response time according to ISO 12238, deactivation time (ms)	35,0 (3 ways) 34,5 (5 ways)

TYPE	
① 32 = 3 ways	
52 = 5 ways	
VOLTAGE	
M9 = Solenoid - Spring (Self-feeding)	
M11 = 24V D.C. (rating power 3,8W)	
✓ M56 = 24V 50/60Hz (starting power 9VA, rating power 6VA)	
M57 = 110 V 50/60Hz (starting power 9VA, rating power 6VA)	
M58 = 230V 50/60Hz (starting power 9VA, rating power 6VA)	

*Shifting time of pneumatic directional control valves or moving parts, logic devices were measured in accordance to ISO 12238:2001*



Weight 160 g  
Minimum working pressure 2,5 bar

T488.32.0.12E.V

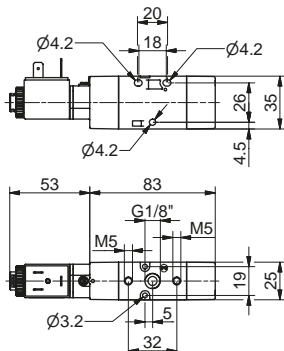

Weight 190 g  
Minimum working pressure 2,5 bar

T488.52.0.12E.V

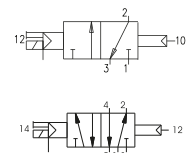
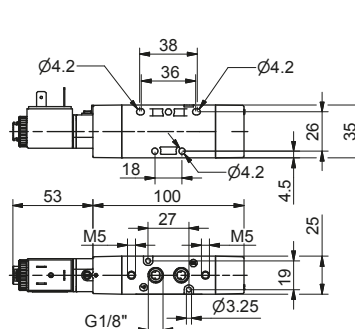

**Solenoid - Solenoid (Self-feeding)**

Coding: T488.Ⓡ.0.0.Ⓥ

Operational characteristics	
Fluid	Filtered air. No lubrication needed, if applied it shall be continuous
Max working pressure (bar)	10
Temperature °C	-5 ÷ +50
Flow rate at 6 bar with Δp=1 (NI/min)	620
Orifice size (mm)	6
Working ports size	G 1/8"
Response time according to ISO 12238, activation time (ms)	18,8 (3 ways) 18,0 (5 ways)
Response time according to ISO 12238, deactivation time (ms)	18,0 (3 ways) 19,1 (5 ways)

*Shifting time of pneumatic directional control valves or moving parts, logic devices were measured in accordance to ISO 12238:2001*

TYPE	
Ⓡ	32 = 3 ways
	52 = 5 ways
VOLTAGE	
	M9 = Solenoid - Spring (Self-feeding)
	M11 = 24V D.C. (rating power 3,8W)
Ⓥ	M56 = 24V 50/60Hz (starting power 9VA, rating power 6VA)
	M57 = 110V 50/60Hz (starting power 9VA, rating power 6VA)
	M58 = 230V 50/60Hz (starting power 9VA, rating power 6VA)



Weight 250 g  
Minimum working pressure 2 bar

Weight 290 g  
Minimum working pressure 2 bar

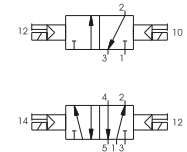
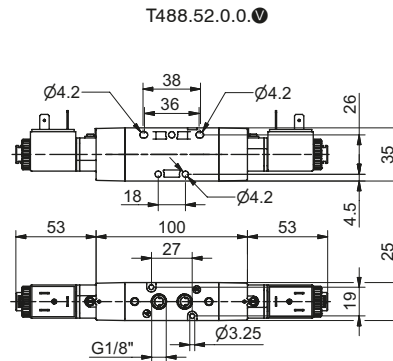
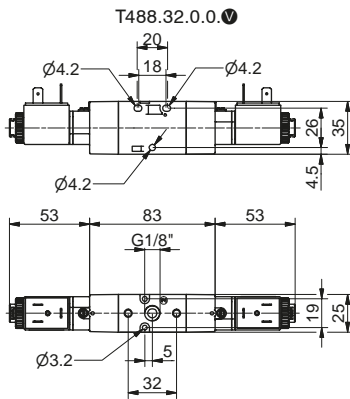

**Solenoid - Solenoid (External-feeding)**

Coding: T488.Ⓡ.0.0.E.Ⓥ

Operational characteristics	
Fluid	Filtered air. No lubrication needed, if applied it shall be continuous
Max working pressure (bar)	10
Temperature °C	-5 ÷ +50
Flow rate at 6 bar with Δp=1 (NI/min)	620
Orifice size (mm)	6
Working ports size	G 1/8"
Response time according to ISO 12238, activation time (ms)	18,8 (3 ways) 18,0 (5 ways)
Response time according to ISO 12238, deactivation time (ms)	18,0 (3 ways) 19,1 (5 ways)

*Shifting time of pneumatic directional control valves or moving parts, logic devices were measured in accordance to ISO 12238:2001*

TYPE	
Ⓡ	32 = 3 ways
	52 = 5 ways
VOLTAGE	
	M9 = Solenoid - Spring (Self-feeding)
	M11 = 24V D.C. (rating power 3,8W)
Ⓥ	M56 = 24V 50/60Hz (starting power 9VA, rating power 6VA)
	M57 = 110V 50/60Hz (starting power 9VA, rating power 6VA)
	M58 = 230V 50/60Hz (starting power 9VA, rating power 6VA)



Weight 250 g  
Minimum working pressure 2 bar

Weight 290 g  
Minimum working pressure 2 bar

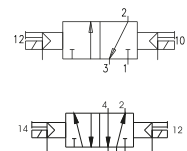
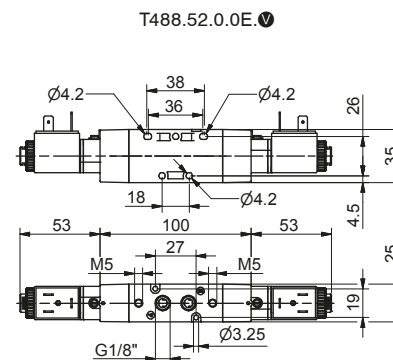
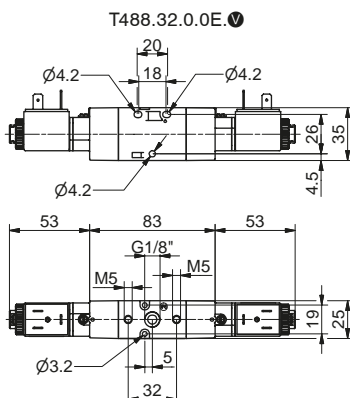

**Solenoid - Solenoid 5 ways 3 connections (Self-feeding)**

Coding: T488.53.F.0.0.V

Operational characteristics	
Fluid	Filtered air. No lubrication needed, if applied it shall be continuous
Max working pressure (bar)	10
Temperature °C	-5 ÷ +50
Flow rate at 6 bar with Δp=1 (NI/min)	410
Orifice size (mm)	6
Working ports size	G 1/8"
Response time according to ISO 12238, activation time (ms)	21,3 (closed centres) 21,5 (open centres) 19,5 (pressured centres)
Response time according to ISO 12238, deactivation time (ms)	37,0 (closed centres) 34,5 (open centres) 37,3 (pressured centres)

Shifting time of pneumatic directional control valves or moving parts, logic devices were measured in accordance to ISO 12238:2001

FUNCTION	
F	31 = Closed centres 32 = Open centres 33 = Pressured centres
VOLTAGE	
M9	= Solenoid - Spring (Self-feeding)
M11	= 24V D.C. (rating power 3,8W)
V	M56 = 24V 50/60Hz (starting power 9VA, rating power 6VA)
	M57 = 110 V 50/60Hz (starting power 9VA, rating power 6VA)
	M58 = 230V 50/60Hz (starting power 9VA, rating power 6VA)

Minimum working pressure 3 bar  
Weight 330 g

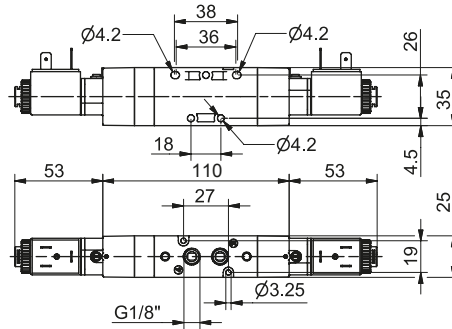

T488.53.31.0.0.V

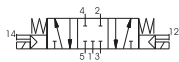

T488.53.32.0.0.V

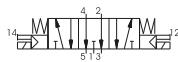

T488.53.33.0.0.V

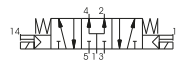

**Solenoid - Solenoid 5/3 (External-feeding)**

Coding: T488.53.F.0.E.V

Operational characteristics	
Fluid	Filtered air. No lubrication needed, if applied it shall be continuous
Max working pressure (bar)	10
Temperature °C	-5 ÷ +50
Flow rate at 6 bar with Δp=1 (NI/min)	410
Orifice size (mm)	6
Working ports size	G 1/8"
Response time according to ISO 12238, activation time (ms)	21,3 (closed centres) 21,5 (open centres) 19,5 (pressured centres)
Response time according to ISO 12238, deactivation time (ms)	37,0 (closed centres) 34,5 (open centres) 37,3 (pressured centres)

Shifting time of pneumatic directional control valves or moving parts, logic devices were measured in accordance to ISO 12238:2001

FUNCTION	
F	31 = Closed centres 32 = Open centres 33 = Pressured centres
VOLTAGE	
M9	= Solenoid - Spring (Self-feeding)
M11	= 24V D.C. (rating power 3,8W)
V	M56 = 24V 50/60Hz (starting power 9VA, rating power 6VA)
	M57 = 110 V 50/60Hz (starting power 9VA, rating power 6VA)
	M58 = 230V 50/60Hz (starting power 9VA, rating power 6VA)

Minimum working pressure 3 bar  
Weight 330 g

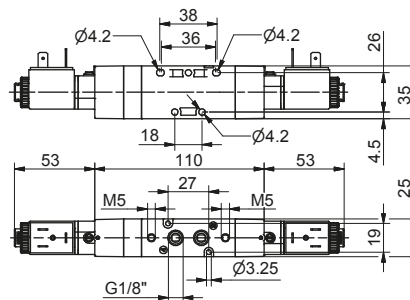

T488.53.31.0.0.E.V

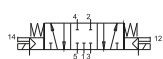

T488.53.32.0.0.E.V



T488.53.33.0.0.E.V

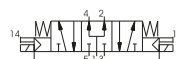



Collectors

Coding: T488.Ⓟ



N. POSITIONS
02 = 2 positions (220 g)
03 = 3 positions (290 g)
04 = 4 positions (360 g)
Ⓟ 05 = 5 positions (430 g)
06 = 6 positions (500 g)
07 = 7 positions (570 g)
08 = 8 positions (640 g)
09 = 9 positions (710 g)
10 = 10 positions (780 g)

1  
AIR DISTRIBUTION

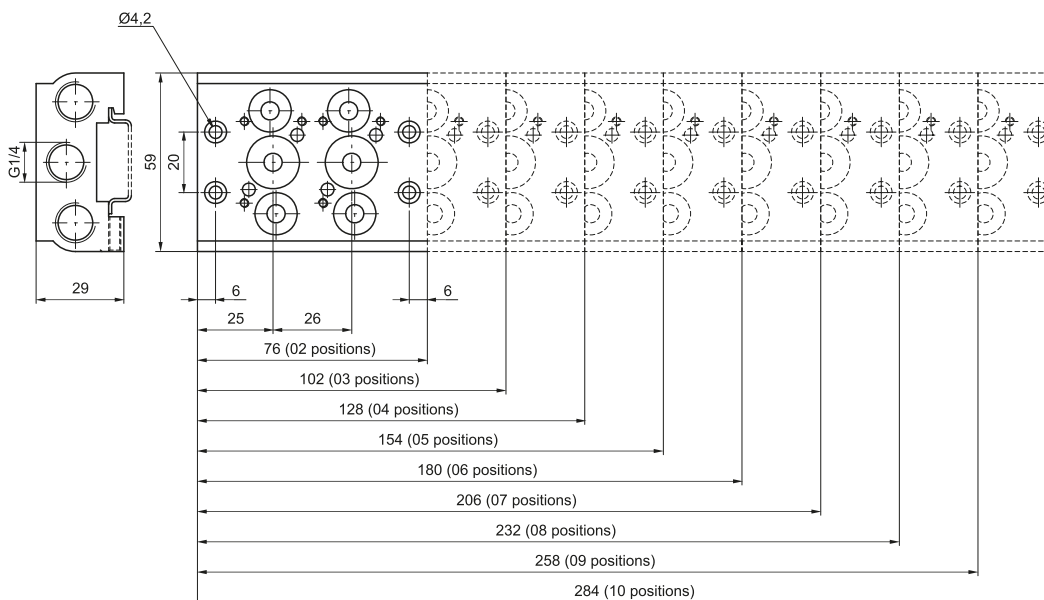

Modular base

Coding: T488.Ⓜ

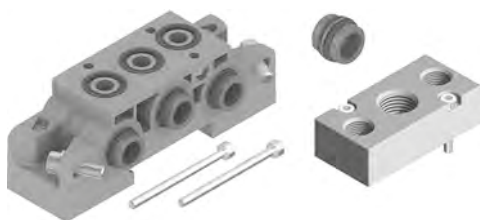

TYPE
01 = Single complete base
01K = Complete modular bases (batches of 20 pieces)
30K = Hollow bush, complete with O-rings (Nr. 50 pieces)
31K = Blank bush, complete with O-rings (Nr. 50 pieces)
Ⓜ 32K = Intermediate air intake with screw (Nr. 5 pieces)
33 = Screw to suite solenoid valves (Nr. 50 pieces)
34 = Screw for joning bases (Nr. 50 pieces)
35 = Washer for screw for joning bases (Nr. 50 pieces)
36 = OR (50 pz)

Closing plate

Coding: T488.00

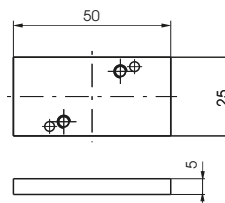

weight 25



**Solenoid - Spring (Self-feeding)**

Coding: T424.Ⓡ.0.1.Ⓟ

Operational characteristics	
Fluid	Filtered air. No lubrication needed, if applied it shall be continuous
Max working pressure (bar)	10
Temperature °C	-5 ÷ +50
Flow rate at 6 bar with Δp=1 (NI/min)	1050
Orifice size (mm)	8.5
Working ports size	G 1/4"

TYPE	
Ⓡ 32 = 3 ways	
52 = 5 ways	
VOLTAGE	
B04 = 12 V DC	
B05 = 24 V DC	
Ⓟ B09 = 24 V DC (2 W)	
B56 = 24 V 50-60 Hz	
B57 = 110 V 50-60 Hz	
B58 = 230 V 50-60 Hz	



Weight 205 g  
Minimum piloting pressure 2,5 bar

T424.32.0.1.Ⓟ

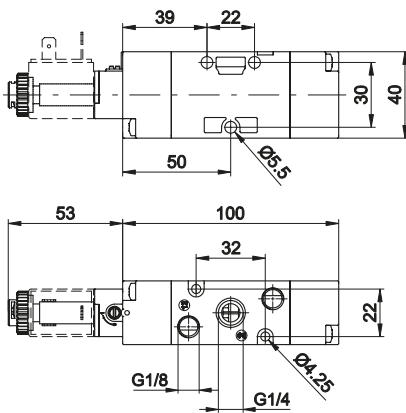

Weight 235 g  
Minimum piloting pressure 2,5 bar

T424.52.0.1.Ⓟ

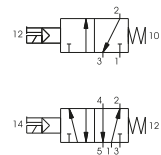
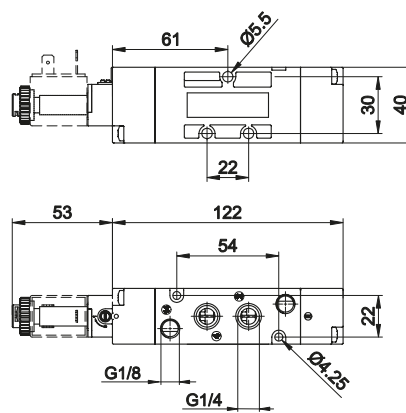

**Solenoid - Spring (External-feeding)**

Coding: T424.Ⓡ.0.1.E.Ⓟ

Operational characteristics	
Fluid	Filtered air. No lubrication needed, if applied it shall be continuous
Max working pressure (bar)	10
Temperature °C	-5 ÷ +50
Flow rate at 6 bar with Δp=1 (NI/min)	1050
Orifice size (mm)	8.5
Working ports size	G 1/4"
Pilot ports size	G 1/8"

TYPE	
Ⓡ 32 = 3 ways	
52 = 5 ways	
VOLTAGE	
B04 = 12 V DC	
B05 = 24 V DC	
Ⓟ B09 = 24 V DC (2 W)	
B56 = 24 V 50-60 Hz	
B57 = 110 V 50-60 Hz	
B58 = 230 V 50-60 Hz	



Weight 205 g  
Minimum piloting pressure 2,5 bar

T424.32.0.1.E.Ⓟ

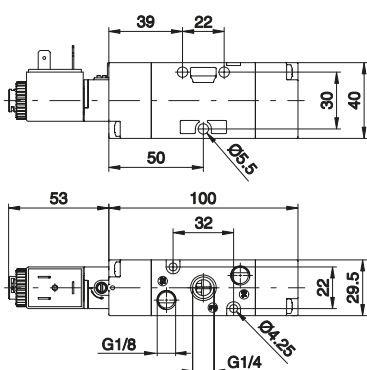

Weight 235 g  
Minimum piloting pressure 2,5 bar

T424.52.0.1.E.Ⓟ

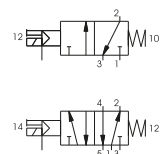
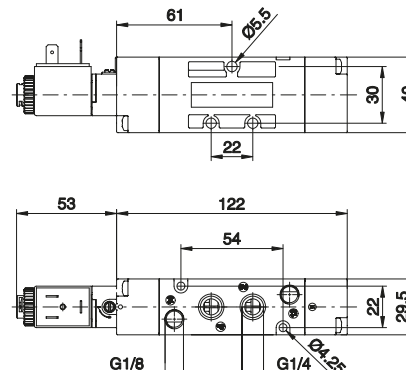

**Solenoid - Differential (Self-feeding)**

Coding: T424.Ⓡ.0.12.Ⓟ

Operational characteristics	
Fluid	Filtered air. No lubrication needed, if applied it shall be continuous
Max working pressure (bar)	10
Temperature °C	-5 ÷ +50
Flow rate at 6 bar with Δp=1 (NI/min)	1050
Orifice size (mm)	8.5
Working ports size	G 1/4"

TYPE	
Ⓡ	32 = 3 ways
	52 = 5 ways
VOLTAGE	
	B04 = 12 V DC
	B05 = 24 V DC
Ⓟ	B09 = 24 V DC (2 W)
	B56 = 24 V 50-60 Hz
	B57 = 110 V 50-60 Hz
	B58 = 230 V 50-60 Hz



Weight 205 g  
Minimum piloting pressure 2 bar

Weight 235 g  
Minimum piloting pressure 2 bar

T424.32.0.12.Ⓟ

T424.52.0.12.Ⓟ

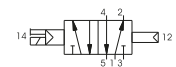
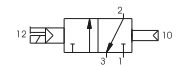
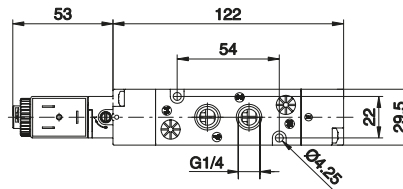
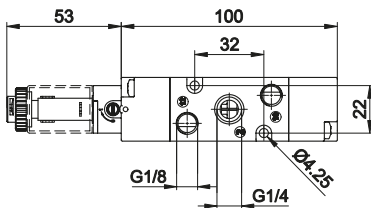
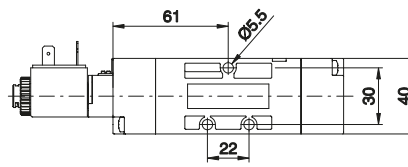
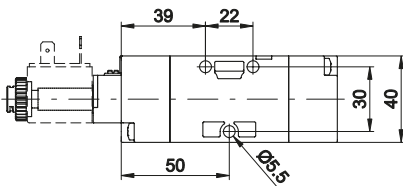

**Solenoid - Differential (External-feeding)**

Coding: T424.Ⓡ.0.12.E.Ⓟ

Operational characteristics	
Fluid	Filtered air. No lubrication needed, if applied it shall be continuous
Max working pressure (bar)	10
Temperature °C	-5 ÷ +50
Flow rate at 6 bar with Δp=1 (NI/min)	1050
Orifice size (mm)	8.5
Working ports size	G 1/4"
Pilot ports size	G 1/8"

TYPE	
Ⓡ	32 = 3 ways
	52 = 5 ways
VOLTAGE	
	B04 = 12 V DC
	B05 = 24 V DC
Ⓟ	B09 = 24 V DC (2 W)
	B56 = 24 V 50-60 Hz
	B57 = 110 V 50-60 Hz
	B58 = 230 V 50-60 Hz



Weight 205 g  
Minimum piloting pressure 2 bar

Weight 235 g  
Minimum piloting pressure 2 bar

T424.32.0.12.E.Ⓟ

T424.52.0.12.E.Ⓟ

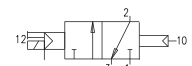
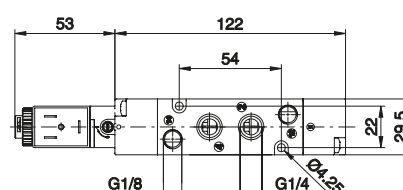
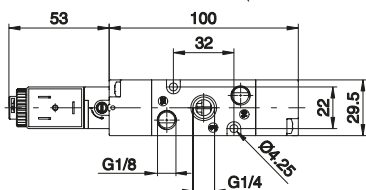
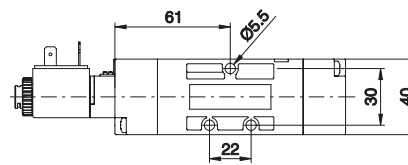
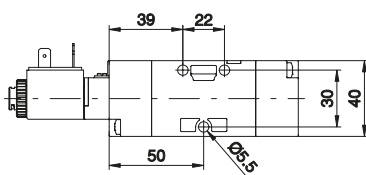

**Solenoid - Solenoid (Self-feeding)**

Coding: T424.1.0.0.0.0

Operational characteristics	
Fluid	Filtered air. No lubrication needed, if applied it shall be continuous
Max working pressure (bar)	10
Temperature °C	-5 ÷ +50
Flow rate at 6 bar with Δp=1 (NI/min)	1050
Orifice size (mm)	8.5
Working ports size	G 1/4"

TYPE	
1 32 = 3 ways	
52 = 5 ways	
VOLTAGE	
B04 = 12 V DC	
B05 = 24 V DC	
09 B09 = 24 V DC (2 W)	
B56 = 24 V 50-60 Hz	
B57 = 110 V 50-60 Hz	
B58 = 230 V 50-60 Hz	



Weight 240 g  
Minimum piloting pressure 2 bar

T424.32.0.0.0.0



Weight 270 g  
Minimum piloting pressure 2 bar

T424.52.0.0.0.0

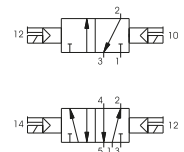
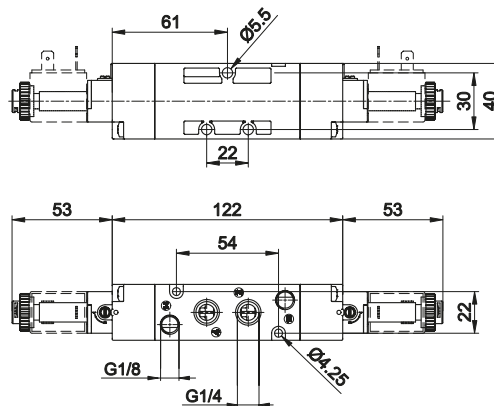
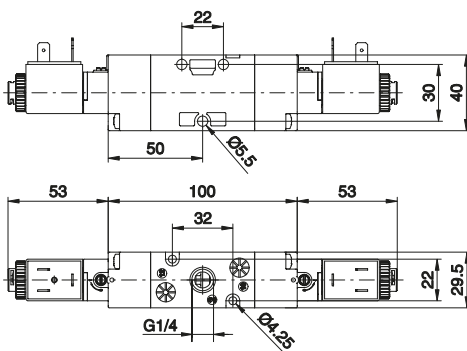

**Solenoid - Solenoid (External-feeding)**

Coding: T424.1.0.0.0.E.0

Operational characteristics	
Fluid	Filtered air. No lubrication needed, if applied it shall be continuous
Max working pressure (bar)	10
Temperature °C	-5 ÷ +50
Flow rate at 6 bar with Δp=1 (NI/min)	1050
Orifice size (mm)	8.5
Working ports size	G 1/4"
Pilot ports size	G 1/8"

TYPE	
1 32 = 3 ways	
52 = 5 ways	
VOLTAGE	
B04 = 12 V DC	
B05 = 24 V DC	
09 B09 = 24 V DC (2 W)	
B56 = 24 V 50-60 Hz	
B57 = 110 V 50-60 Hz	
B58 = 230 V 50-60 Hz	



Weight 240 g  
Minimum piloting pressure 2 bar

T424.32.0.0.0.E.0

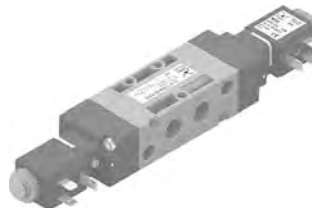

Weight 270 g  
Minimum piloting pressure 2 bar

T424.52.0.0.0.E.0

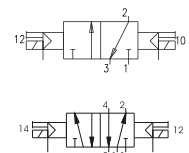
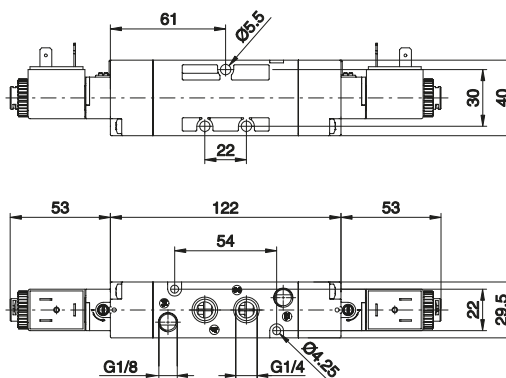
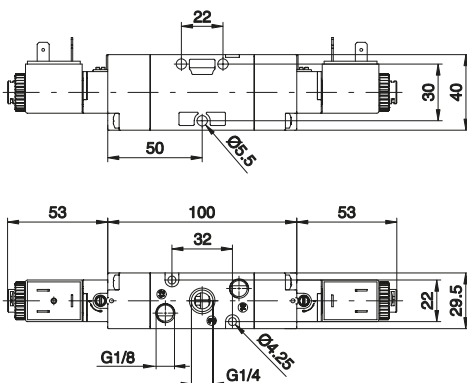

**Solenoid - Solenoid (Self-feeding)**

Coding: T424.53.Ⓡ.0.0.Ⓥ

Operational characteristics	
Fluid	Filtered air. No lubrication needed, if applied it shall be continuous
Max working pressure (bar)	10
Temperature °C	-5 ÷ +50
Flow rate at 6 bar with Δp=1 (NI/min)	900
Orifice size (mm)	8.5
Working ports size	G 1/4"

FUNCTION	
Ⓡ	31 = Closed centres
	32 = Open centres
	33 = Pressured centres
VOLTAGE	
	B04 = 12 V DC
	B05 = 24 V DC
Ⓥ	B09 = 24 V DC (2 W)
	B56 = 24 V 50-60 Hz
	B57 = 110 V 50-60 Hz
	B58 = 230 V 50-60 Hz

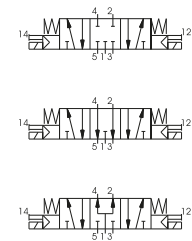
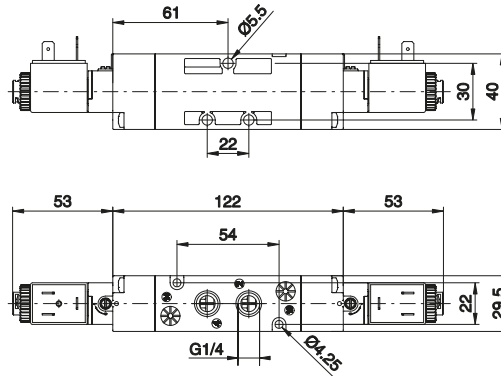
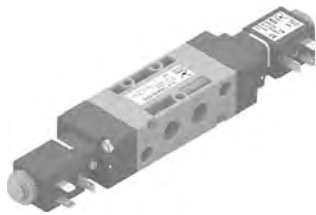

Weight 295 g  
Minimum piloting pressure 3 bar

**Solenoid - Solenoid (External-feeding)**

Coding: T424.53.Ⓡ.0.0.E.Ⓥ

Operational characteristics	
Fluid	Filtered air. No lubrication needed, if applied it shall be continuous
Max working pressure (bar)	10
Temperature °C	-5 ÷ +50
Flow rate at 6 bar with Δp=1 (NI/min)	900
Orifice size (mm)	8.5
Working ports size	G 1/4"
Pilot ports size	G 1/8"

FUNCTION	
Ⓡ	31 = Closed centres
	32 = Open centres
	33 = Pressured centres
VOLTAGE	
	B04 = 12 V DC
	B05 = 24 V DC
Ⓥ	B09 = 24 V DC (2 W)
	B56 = 24 V 50-60 Hz
	B57 = 110 V 50-60 Hz
	B58 = 230 V 50-60 Hz

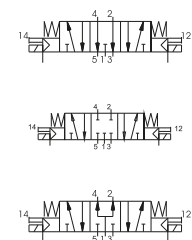
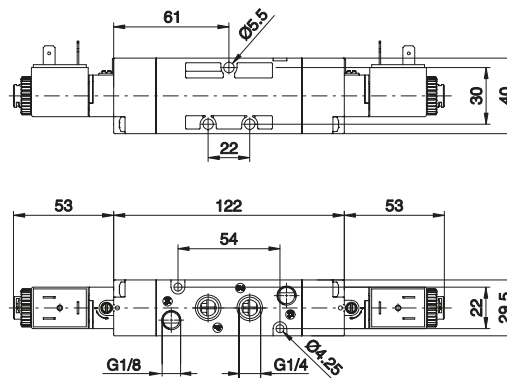

Weight 295 g  
Minimum piloting pressure 3 bar

Collectors



Coding: T424.**N**

N. POSITIONS	
<b>02</b>	2 positions (weight 350 g)
<b>03</b>	3 positions (weight 420 g)
<b>04</b>	4 positions (weight 560 g)
<b>05</b>	5 positions (weight 670 g)
<b>06</b>	6 positions (weight 770 g)
<b>07</b>	7 positions (weight 880 g)
<b>08</b>	8 positions (weight 980 g)
<b>09</b>	9 positions (weight 1090 g)
<b>10</b>	10 positions (weight 1200 g)

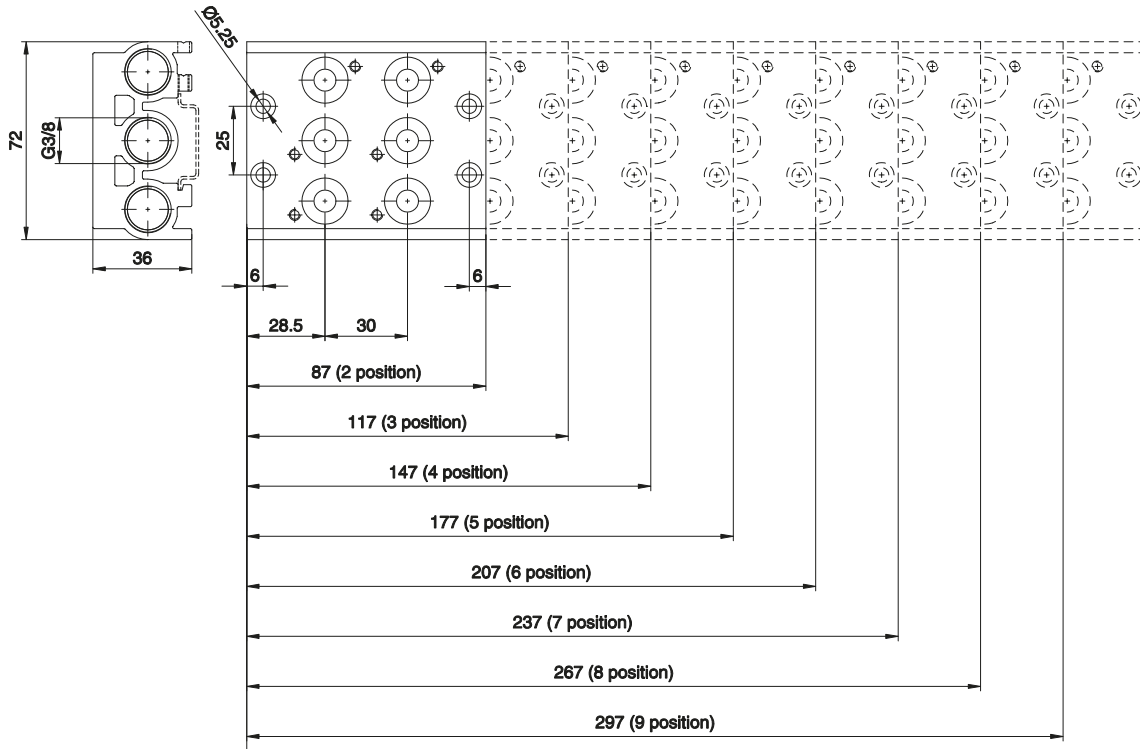

Modular collectors



Coding: T424.**T**

TYPE	
<b>01</b>	Single complete base
<b>01K</b>	Complete modular bases (batches of 15 pieces)
<b>30K</b>	Hollow bush, complete with O-rings (Nr. 50 pieces)
<b>31K</b>	Blank bush, complete with O-rings (Nr. 50 pieces)
<b>32K</b>	Intermediate air intake with screw (Nr. 5 pieces)
<b>33</b>	Screw to suite solenoid valves (Nr. 50 pieces)
<b>34</b>	Screw for joining bases (Nr. 50 pieces)
<b>35</b>	Washer for screw for joining bases (Nr. 50 pieces)
<b>36</b>	OR (50 pz)

Closing plate

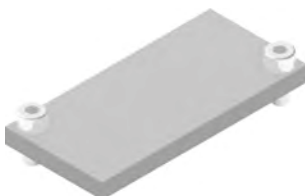

Coding: T424.00

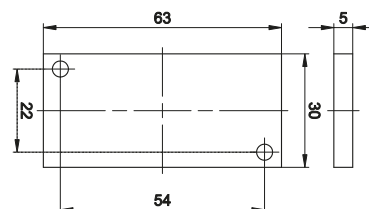

Weight 25 g



**Series 2100 - 2400 - 2600**

**General**

The 2000 series solenoid valves have been developed to meet requirements for electronically controlled pneumatic systems and / or serial control systems already used in all manufacturing sectors. They have been designed to be easily assembled into groups or manifolds and include integral electrical connection (2100 and 2400), to facilitate simple and speedy integration into a control system. The series comprises a range of products classified according to type, size and performance. There are three main sizes, 10mm., 18 mm. and 26 mm., with each size further divided into 3 types "LINE", "FLAT" and "VDMA" or "BASE". The 10mm. and 18 mm. 24 VDC range of valves includes a range of accessories for the production of manifolded valve assemblies with integral electrical connections. Modules are available in two or four station variants for flexibility and are supplied to IP40 or alternatively IP65 environmental protection.

**Construction characteristics**

	Series 2100	Series 2400	Series 2600
Central body	Extruded aluminium bar with chemical nickel treatment and PTFE (polytetrafluorethylene)	Extruded aluminium bar with chemical nickel treatment and PTFE (polytetrafluorethylene)	Extruded aluminium bar with chemical nickel treatment and PTFE (polytetrafluorethylene)
Connection plates	Technopolymer	Zincalloy	Die-cast aluminium
Piston seals	Oil resistant nitrile rubber - NBR	Oil resistant nitrile rubber - NBR	Oil resistant nitrile rubber - NBR
Spool seals	Oil resistant nitrile rubber - HNBR	Oil resistant nitrile rubber - HNBR	Oil resistant nitrile rubber - HNBR
Springs	AISI 302 stainless steel	AISI 302 stainless steel	AISI 302 stainless steel
Operators	Technopolymer	Technopolymer	Technopolymer
Pistons	Aluminium 2011	Technopolymer	Technopolymer
Spools	Aluminium 2011	Aluminium 2011	Aluminium 2011

**Use and maintenance**

The average life of the valve exceeds 50.000.000 cycles when used under optimum conditions. Adequate lubrication reduces seals wear, just as proper filtering of supply air prevents the build-up of dirt that can cause malfunction. Ensure the valve is used within our recommended criteria for pressure and temperature. In dirty or dusty environments, the exhaust ports should be protected. A seal kit including the spool is available for overhauling the valve. This operation does not require a skilled worker, although a particular care should be taken when reassembling the valve.

1 AIR DISTRIBUTION



## Series 2100

### General

This solenoid valves series has been developed to meet requirements for electronically controlled pneumatic systems and / or serial control systems already used in all manufacturing sectors.  
They have been designed to be easily assembled into groups or manifolds and include integral electrical connection to facilitate simple and speedy integration into a control system.  
The 2100 series comprises a range of products classified according to the body size of 10mm divided into 3 types "LINE", "FLAT" and "BASE".  
The 10mm. and 18 mm. 24 VDC range of valves includes a range of accessories for the production of manifolded valve assemblies with integral electrical connections.  
Modules are available in two or four station variants for flexibility and are supplied to IP40 or alternatively IP65 environmental protection.

### Construction characteristics

Central body	Extruded aluminium bar with chemical nickel treatment and PTFE (polytetrafluorethylene)
Connection plates	Technopolymer
Operators	Technopolymer
Spool seals	Oil resistant nitrile rubber - HNBR
Spools	Aluminium 2011
Springs	AISI 302 stainless steel
Pistons	Aluminium 2011
Piston seals	Oil resistant nitrile rubber - NBR

### Ordering codes for miniature solenoid valves

The 10 mm. miniature solenoid valve with 0,7 mm. orifice has been selected for piloting this series of valves (see Series 300). This results in low response times and reduced power consumption.  
The valve can be supplied with the coil upward or downward depending on the application.

Codes are as follows:

#### Coil upward code

01 = miniature sol. 12 VDC 90°conn. with led  
21 = miniature sol. 12 VDC line conn. with led  
02 = miniature sol. 24 VDC 90°conn. with led  
22 = miniature sol. 24 VDC line conn. with led

#### Coil downward code

11 = miniature sol. 12 VDC 90° conn. with led  
31 = miniature sol. 12 VDC line conn. with led  
12 = miniature sol. 24 VDC 90°conn. with led  
32 = miniature sol. 24 VDC line conn. with led  
91 = miniature sol. 12 VDC for integral electrical connections  
92 = miniature sol. 24 VDC for integral electrical connections

Miniature solenoid  homologated are available (see Series 300).

### Use and maintenance

The average life of the solenoid valve exceeds 50.000.000 cycles when used under optimum conditions.  
Adequate lubrication reduces seals wear, just as proper filtering of supply air prevents the build-up of dirt that can cause malfunction.  
Ensure the valve is used within our recommended criteria for pressure and temperature.  
In dirty or dusty environments, the exhaust ports should be protected.  
A seal kit including the spool is available for overhauling the valve. This operation does not require a skilled worker, although a particular care should be taken when reassembling the valve.

1  
AIR DISTRIBUTION



AIR DISTRIBUTION

1

**Pneumatic - Spring**

Coding: 2115.52.00.19

**Operational characteristics**

Fluid	Filtered air. No lubrication needed, if applied it shall be continuous
Max working pressure (bar)	7
Temperature °C	-5 ÷ +50
Flow rate at 6 bar with Δp=1 (NI/min)	150
Orifice size (mm)	2.5
Working ports size	M5



Weight 30 g  
Minimum piloting pressure 2 bar

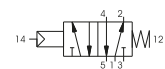
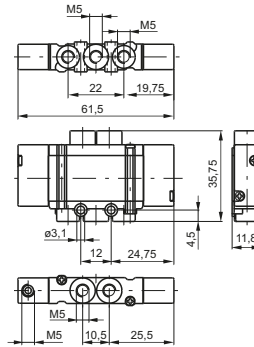

**Pneumatic - Differential**

Coding: 2115.52.00.16

**Operational characteristics**

Fluid	Filtered air. No lubrication needed, if applied it shall be continuous
Max working pressure (bar)	7
Temperature °C	-5 ÷ +50
Flow rate at 6 bar with Δp=1 (NI/min)	150
Orifice size (mm)	2.5
Working ports size	M5



Weight 28 g  
Minimum piloting pressure 2 bar

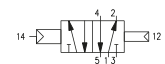
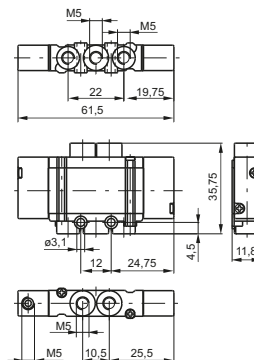

**Pneumatic - Pneumatic**

Coding: 2115.52.00.18

**Operational characteristics**

Fluid	Filtered air. No lubrication needed, if applied it shall be continuous
Max working pressure (bar)	7
Temperature °C	-5 ÷ +50
Flow rate at 6 bar with Δp=1 (NI/min)	150
Orifice size (mm)	2.5
Working ports size	M5



Weight 30 g  
Minimum piloting pressure 2 bar

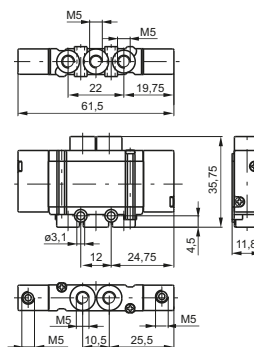



**Solenoid - Spring**

Coding: 2115.52.00.39. **T**

Operational characteristics	
Fluid	Filtered air. No lubrication needed, if applied it shall be continuous
Max working pressure (bar)	7
Temperature °C	-5 ÷ +50
Flow rate at 6 bar with Δp=1 (NI/min)	150
Orifice size (mm)	2.5
Working ports size	M5

VOLTAGE	
<b>01</b>	= 12 VDC 90° conn. with led
<b>21</b>	= 12 VDC line conn. with led
<b>02</b>	= 24 VDC 90° conn. with led
<b>22</b>	= 24 VDC line conn. with led
<b>11</b>	= 12 VDC 90° conn. with led downward
<b>31</b>	= 12 VDC line conn. with led downward
<b>12</b>	= 24 VDC 90° conn. with led downward
<b>32</b>	= 24 VDC line conn. with led downward



Weight 42 g  
Minimum piloting pressure 2 bar

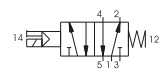
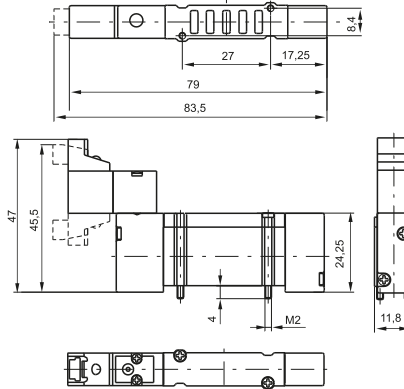

**Solenoid - Differential**

Coding: 2115.52.00.36. **T**

Operational characteristics	
Fluid	Filtered air. No lubrication needed, if applied it shall be continuous
Max working pressure (bar)	7
Temperature °C	-5 ÷ +50
Flow rate at 6 bar with Δp=1 (NI/min)	150
Orifice size (mm)	2.5
Working ports size	M5

VOLTAGE	
<b>01</b>	= 12 VDC 90° conn. with led
<b>21</b>	= 12 VDC line conn. with led
<b>02</b>	= 24 VDC 90° conn. with led
<b>22</b>	= 24 VDC line conn. with led
<b>11</b>	= 12 VDC 90° conn. with led downward
<b>31</b>	= 12 VDC line conn. with led downward
<b>12</b>	= 24 VDC 90° conn. with led downward
<b>32</b>	= 24 VDC line conn. with led downward



Weight 42 g  
Minimum piloting pressure 2 bar

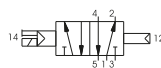
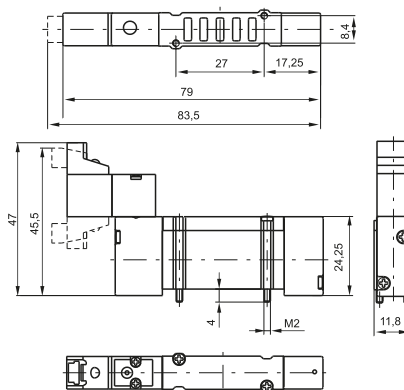

**Solenoid - Solenoid**

Coding: 2115.52.00.35. **T**

Operational characteristics	
Fluid	Filtered air. No lubrication needed, if applied it shall be continuous
Max working pressure (bar)	7
Temperature °C	-5 ÷ +50
Flow rate at 6 bar with Δp=1 (NI/min)	150
Orifice size (mm)	2.5
Working ports size	M5

VOLTAGE	
<b>01</b>	= 12 VDC 90° conn. with led
<b>21</b>	= 12 VDC line conn. with led
<b>02</b>	= 24 VDC 90° conn. with led
<b>22</b>	= 24 VDC line conn. with led
<b>11</b>	= 12 VDC 90° conn. with led downward
<b>31</b>	= 12 VDC line conn. with led downward
<b>12</b>	= 24 VDC 90° conn. with led downward
<b>32</b>	= 24 VDC line conn. with led downward



Weight 52 g  
Minimum piloting pressure 2 bar

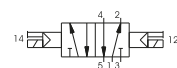
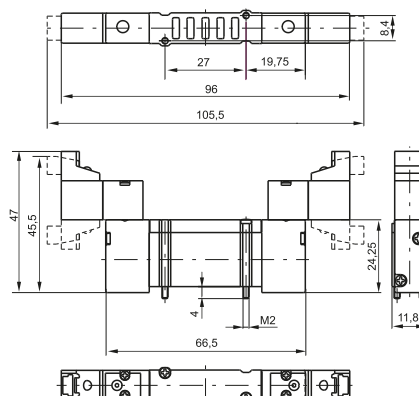



# Spool valves and solenoid valves Series 2100 - Size10mm LINE

## Pneumatic - Pneumatic

Coding: 2115.53. **F**.18

Operational characteristics	
Fluid	Filtered air. No lubrication needed, if applied it shall be continuous
Max working pressure (bar)	7
Temperature °C	-5 ÷ +50
Flow rate at 6 bar with Δp=1 (NI/min)	180 (Pressured centres) 130 (Closed centres) 140 (Open centres)
Orifice size (mm)	2.5
Working ports size	M5

FUNCTION	
<b>F</b>	31 = Closed centres
	32 = Open centres
	33 = Pressured centres

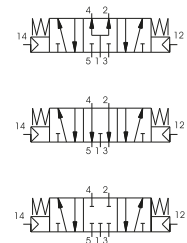
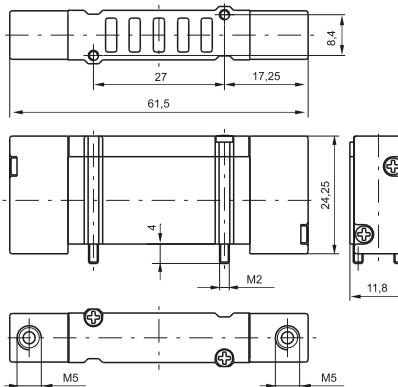

Weight 32 g  
Minimum piloting pressure 2,5 bar

## Solenoid - Solenoid

Coding: 2115.53. **F**.35. **T**

Operational characteristics	
Fluid	Filtered air. No lubrication needed, if applied it shall be continuous
Max working pressure (bar)	7
Temperature °C	-5 ÷ +50
Flow rate at 6 bar with Δp=1 (NI/min)	180 (Pressured centres) 130 (Closed centres) 140 (Open centres)
Orifice size (mm)	2.5
Working ports size	M5

FUNCTION	
<b>F</b>	31 = Closed centres
	32 = Open centres
	33 = Pressured centres
VOLTAGE	
<b>01</b>	12 VDC 90° conn. with led
<b>21</b>	12 VDC line conn. with led
<b>02</b>	24 VDC 90° conn. with led
<b>22</b>	24 VDC line conn. with led
<b>11</b>	12 VDC 90° conn. with led downward
<b>T</b>	31 = 12 VDC line conn. with led downward
	12 = 24 VDC 90° conn. with led downward
	32 = 24 VDC line conn. with led downward

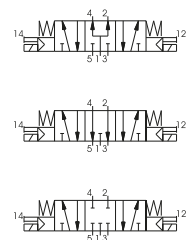
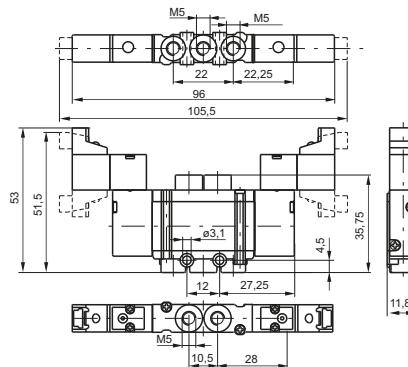

Weight 54 g  
Minimum piloting pressure 2,5 bar

AIR DISTRIBUTION

**Pneumatic - Spring**

Coding: 2135.52.00.19

Operational characteristics	
Fluid	Filtered air. No lubrication needed, if applied it shall be continuous
Max working pressure (bar)	7
Temperature °C	-5 ÷ +50
Flow rate at 6 bar with $\Delta p=1$ (NI/min)	150
Orifice size (mm)	2.5
Working ports size	M5



Weight 32 g  
Minimum piloting pressure 2 bar

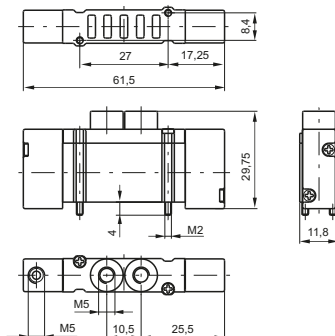

**Pneumatic - Differential**

Coding: 2135.52.00.16

Operational characteristics	
Fluid	Filtered air. No lubrication needed, if applied it shall be continuous
Max working pressure (bar)	7
Temperature °C	-5 ÷ +50
Flow rate at 6 bar with $\Delta p=1$ (NI/min)	150
Orifice size (mm)	2.5
Working ports size	M5



Weight 30 g  
Minimum piloting pressure 2 bar

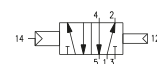
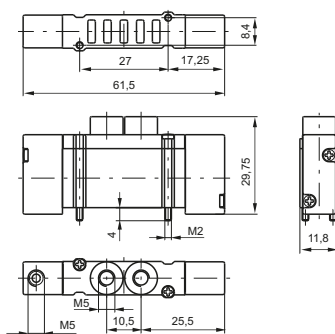

**Pneumatic - Pneumatic**

Coding: 2135.52.00.18

Operational characteristics	
Fluid	Filtered air. No lubrication needed, if applied it shall be continuous
Max working pressure (bar)	7
Temperature °C	-5 ÷ +50
Flow rate at 6 bar with $\Delta p=1$ (NI/min)	150
Orifice size (mm)	2.5
Working ports size	M5



Weight 32 g  
Minimum piloting pressure 2 bar

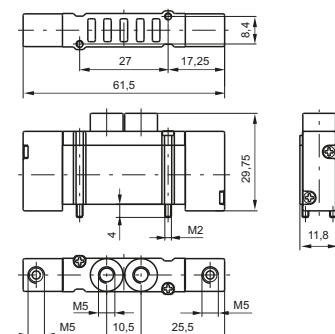



AIR DISTRIBUTION

**Solenoid - Spring**

Coding: 2135.52.00.39.

Operational characteristics	
Fluid	Filtered air. No lubrication needed, if applied it shall be continuous
Max working pressure (bar)	7
Temperature °C	-5 ÷ +50
Flow rate at 6 bar with Δp=1 (NI/min)	150
Orifice size (mm)	2.5
Working ports size	M5

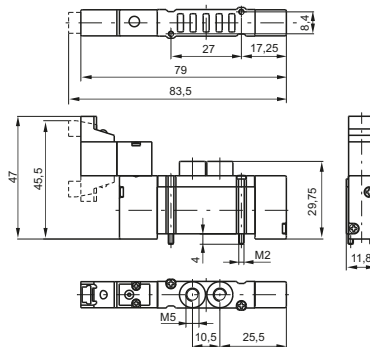

Weight 38 g  
Minimum piloting pressure 2 bar

VOLTAGE
01 = 12 VDC 90° conn. with led
21 = 12 VDC line conn. with led
02 = 24 VDC 90° conn. with led
22 = 24 VDC line conn. with led
11 = 12 VDC 90° conn. with led downward
31 = 12 VDC line conn. with led downward
12 = 24 VDC 90° conn. with led downward
32 = 24 VDC line conn. with led downward
91 = 12 VDC for integral electrical connections downward
92 = 24 VDC for integral electrical connections downward

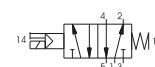

**Solenoid - Differential**

Coding: 2135.52.00.36.

Operational characteristics	
Fluid	Filtered air. No lubrication needed, if applied it shall be continuous
Max working pressure (bar)	7
Temperature °C	-5 ÷ +50
Flow rate at 6 bar with Δp=1 (NI/min)	150
Orifice size (mm)	2.5
Working ports size	M5

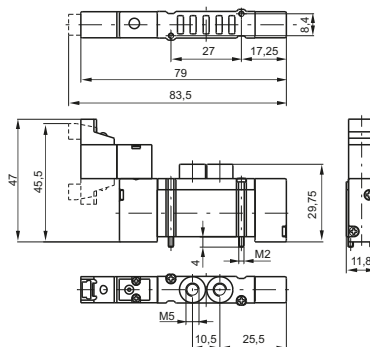

Weight 38 g  
Minimum piloting pressure 2 bar

VOLTAGE
01 = 12 VDC 90° conn. with led
21 = 12 VDC line conn. with led
02 = 24 VDC 90° conn. with led
22 = 24 VDC line conn. with led
11 = 12 VDC 90° conn. with led downward
31 = 12 VDC line conn. with led downward
12 = 24 VDC 90° conn. with led downward
32 = 24 VDC line conn. with led downward
91 = 12 VDC for integral electrical connections downward
92 = 24 VDC for integral electrical connections downward

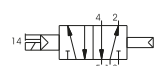

**Solenoid - Solenoid**

Coding: 2135.52.00.35.

Operational characteristics	
Fluid	Filtered air. No lubrication needed, if applied it shall be continuous
Max working pressure (bar)	7
Temperature °C	-5 ÷ +50
Flow rate at 6 bar with Δp=1 (NI/min)	150
Orifice size (mm)	2.5
Working ports size	M5

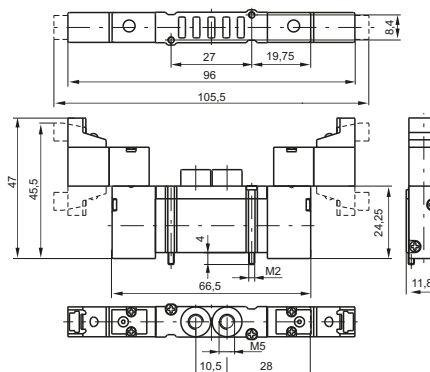

Weight 50 g  
Minimum piloting pressure 1,5 bar

VOLTAGE
01 = 12 VDC 90° conn. with led
21 = 12 VDC line conn. with led
02 = 24 VDC 90° conn. with led
22 = 24 VDC line conn. with led
11 = 12 VDC 90° conn. with led downward
31 = 12 VDC line conn. with led downward
12 = 24 VDC 90° conn. with led downward
32 = 24 VDC line conn. with led downward
91 = 12 VDC for integral electrical connections downward
92 = 24 VDC for integral electrical connections downward



**Pneumatic - Pneumatic**

Coding: 2135.53.F.18

Operational characteristics	
Fluid	Filtered air. No lubrication needed, if applied it shall be continuous
Max working pressure (bar)	7
Temperature °C	-5 ÷ +50
Flow rate at 6 bar with Δp=1 (NI/min)	180 (Pressured centres) 130 (Closed centres) 140 (Open centres)
Orifice size (mm)	2.5
Working ports size	M5

FUNCTION	
F	31 = Closed centres
	32 = Open centres
	33 = Pressured centres

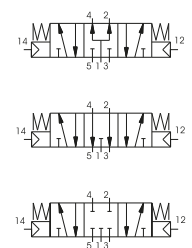
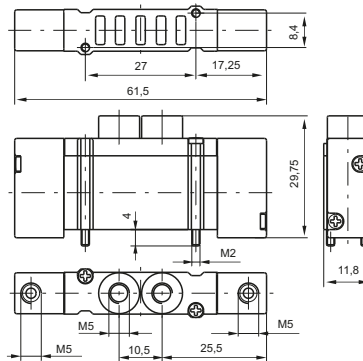

Weight 28 g  
Minimum piloting pressure 2 bar

1  
AIR DISTRIBUTION

**Solenoid - Solenoid**

Coding: 2135.53.F.35.T

Operational characteristics	
Fluid	Filtered air. No lubrication needed, if applied it shall be continuous
Max working pressure (bar)	7
Temperature °C	-5 ÷ +50
Flow rate at 6 bar with Δp=1 (NI/min)	180 (Pressured centres) 130 (Closed centres) 140 (Open centres)
Orifice size (mm)	2.5
Working ports size	M5

FUNCTION	
F	31 = Closed centres
	32 = Open centres
	33 = Pressured centres
VOLTAGE	
01	= 12 VDC 90° conn. with led
21	= 12 VDC line conn. with led
02	= 24 VDC 90° conn. with led
22	= 24 VDC line conn. with led
11	= 12 VDC 90° conn. with led downward
31	= 12 VDC line conn. with led downward
T	12 = 24 VDC 90° conn. with led downward
	32 = 24 VDC line conn. with led downward
	91 = 12 VDC for integral electrical connections downward
	92 = 24 VDC for integral electrical connections downward

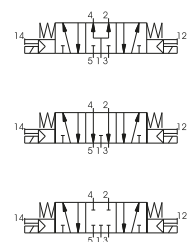
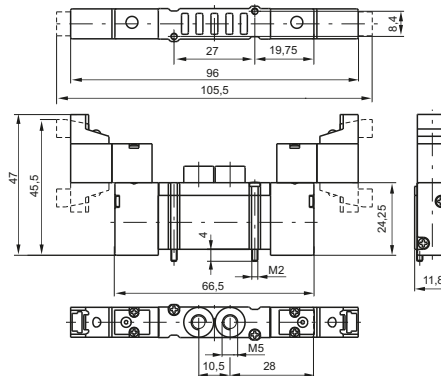

Weight 52 g  
Minimum piloting pressure 2.5 bar



AIR DISTRIBUTION

**Pneumatic - Spring**

Coding: 2141.52.00.19

**Operational characteristics**

Fluid	Filtered air. No lubrication needed, if applied it shall be continuous
Max working pressure (bar)	7
Temperature °C	-5 ÷ +50
Flow rate at 6 bar with Δp=1 (NI/min)	150
Orifice size (mm)	2.5
Working ports size	M5

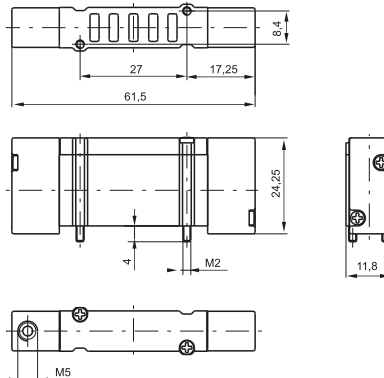

Weight 24 g  
Minimum piloting pressure 2 bar

**Pneumatic - Differential**

Coding: 2141.52.00.16

**Operational characteristics**

Fluid	Filtered air. No lubrication needed, if applied it shall be continuous
Max working pressure (bar)	7
Temperature °C	-5 ÷ +50
Flow rate at 6 bar with Δp=1 (NI/min)	150
Orifice size (mm)	2.5
Working ports size	M5

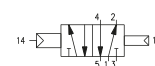
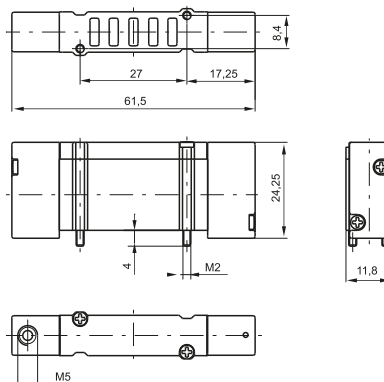

Weight 22 g  
Minimum piloting pressure 2 bar

**Pneumatic - Pneumatic**

Coding: 2141.52.00.18

**Operational characteristics**

Fluid	Filtered air. No lubrication needed, if applied it shall be continuous
Max working pressure (bar)	7
Temperature °C	-5 ÷ +50
Flow rate at 6 bar with Δp=1 (NI/min)	150
Orifice size (mm)	2.5
Working ports size	M5

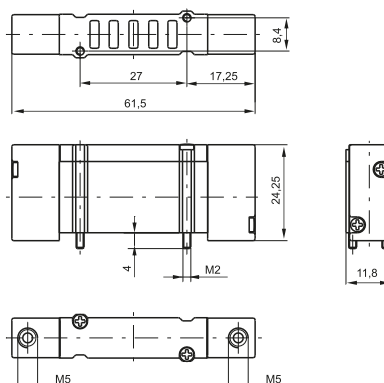

Weight 26 g  
Minimum piloting pressure 1,5 bar

**Solenoid - Spring**

Coding: 2141.52.00.39. **T**

Operational characteristics	
Fluid	Filtered air. No lubrication needed, if applied it shall be continuous
Max working pressure (bar)	7
Temperature °C	-5 ÷ +50
Flow rate at 6 bar with Δp=1 (NI/min)	150
Orifice size (mm)	2.5
Working ports size	M5



Weight 38 g  
Minimum piloting pressure 2 bar

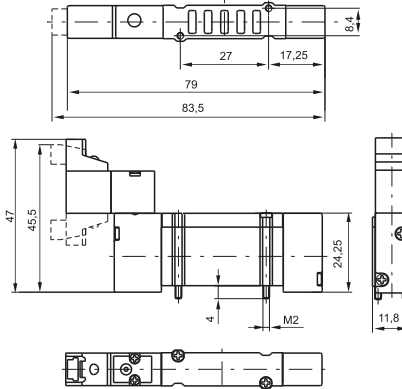

VOLTAGE
01 = 12 VDC 90° conn. with led
21 = 12 VDC line conn. with led
02 = 24 VDC 90° conn. with led
22 = 24 VDC line conn. with led
11 = 12 VDC 90° conn. with led downward
31 = 12 VDC line conn. with led downward
12 = 24 VDC 90° conn. with led downward
32 = 24 VDC line conn. with led downward
91 = 12 VDC for integral electrical connections downward
92 = 24 VDC for integral electrical connections downward



**Solenoid - Differential**

Coding: 2141.52.00.36. **T**

Operational characteristics	
Fluid	Filtered air. No lubrication needed, if applied it shall be continuous
Max working pressure (bar)	7
Temperature °C	-5 ÷ +50
Flow rate at 6 bar with Δp=1 (NI/min)	150
Orifice size (mm)	2.5
Working ports size	M5



Weight 38 g  
Minimum piloting pressure 2 bar

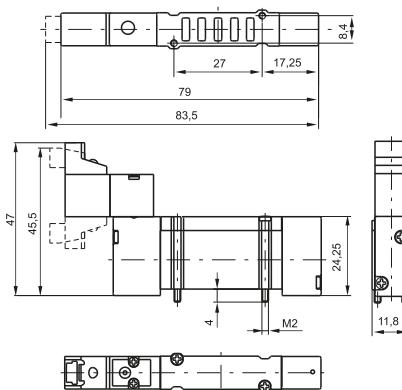

VOLTAGE
01 = 12 VDC 90° conn. with led
21 = 12 VDC line conn. with led
02 = 24 VDC 90° conn. with led
22 = 24 VDC line conn. with led
11 = 12 VDC 90° conn. with led downward
31 = 12 VDC line conn. with led downward
12 = 24 VDC 90° conn. with led downward
32 = 24 VDC line conn. with led downward
91 = 12 VDC for integral electrical connections downward
92 = 24 VDC for integral electrical connections downward



**Solenoid - Solenoid**

Coding: 2141.52.00.35. **T**

Operational characteristics	
Fluid	Filtered air. No lubrication needed, if applied it shall be continuous
Max working pressure (bar)	7
Temperature °C	-5 ÷ +50
Flow rate at 6 bar with Δp=1 (NI/min)	150
Orifice size (mm)	2.5
Working ports size	M5



Weight 48 g  
Minimum piloting pressure 1,5 bar

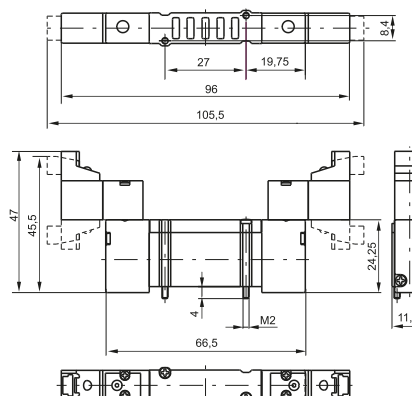

VOLTAGE
01 = 12 VDC 90° conn. with led
21 = 12 VDC line conn. with led
02 = 24 VDC 90° conn. with led
22 = 24 VDC line conn. with led
11 = 12 VDC 90° conn. with led downward
31 = 12 VDC line conn. with led downward
12 = 24 VDC 90° conn. with led downward
32 = 24 VDC line conn. with led downward
91 = 12 VDC for integral electrical connections downward
92 = 24 VDC for integral electrical connections downward





# Spool valves and solenoid valves Series 2100 - Size 10mm BASE

## Pneumatic - Pneumatic

Coding: 2141.53.F.18

Operational characteristics	
Fluid	Filtered air. No lubrication needed, if applied it shall be continuous
Max working pressure (bar)	7
Temperature °C	-5 ÷ +50
Flow rate at 6 bar with Δp=1 (NI/min)	180 (Pressured centres) 130 (Closed centres) 140 (Open centres)
Orifice size (mm)	2.5
Working ports size	M5

FUNCTION	
<b>F</b>	31 = Closed centres
	32 = Open centres
	33 = Pressured centres

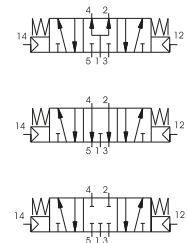
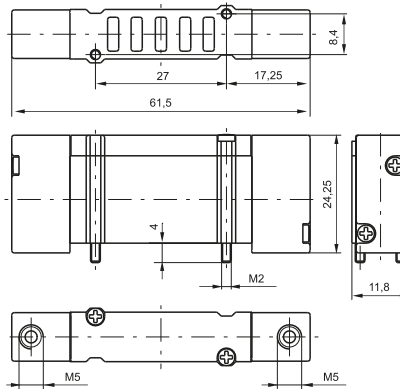

Weight 28 g  
Minimum working pressure 2 bar

## Solenoid - Solenoid

Coding: 2141.53.F.35.T

Operational characteristics	
Fluid	Filtered air. No lubrication needed, if applied it shall be continuous
Max working pressure (bar)	7
Temperature °C	-5 ÷ +50
Flow rate at 6 bar with Δp=1 (NI/min)	180 (Pressured centres) 130 (Closed centres) 140 (Open centres)
Orifice size (mm)	2.5
Working ports size	M5

FUNCTION	
<b>F</b>	31 = Closed centres
	32 = Open centres
	33 = Pressured centres
VOLTAGE	
<b>01</b>	= 12 VDC 90° conn. with led
<b>21</b>	= 12 VDC line conn. with led
<b>02</b>	= 24 VDC 90° conn. with led
<b>22</b>	= 24 VDC line conn. with led
<b>11</b>	= 12 VDC 90° conn. with led downward
<b>31</b>	= 12 VDC line conn. with led downward
<b>T</b>	<b>12</b> = 24 VDC 90° conn. with led downward
	<b>32</b> = 24 VDC line conn. with led downward
	<b>91</b> = 12 VDC for integral electrical connections downward
	<b>92</b> = 24 VDC for integral electrical connections downward

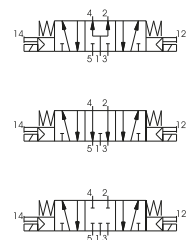
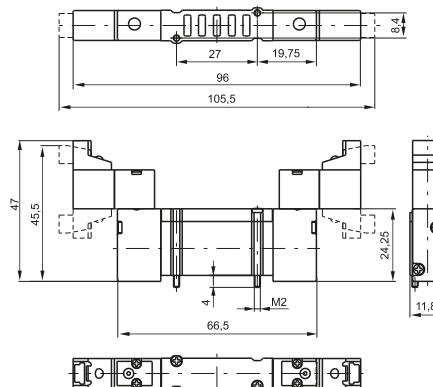

Weight 52 g  
Minimum piloting pressure 2,5 bar

AIR DISTRIBUTION



► Modular base for "BASE" version



Weight 22 g

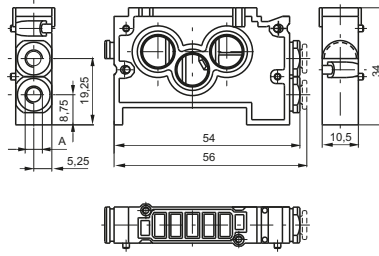

Coding: 214<sup>✓</sup>.01

VARIANTS	
0	= modular BASE without cartridges
4	= modular base c/w with 4mm tube cartridges
<sup>✓</sup> 5	= modular base c/w with M5 cartridges
7	= modular base c/w with M7x1 cartridges

► Modular BASE c/w with 6mm tube cartridges



Weight 22 g

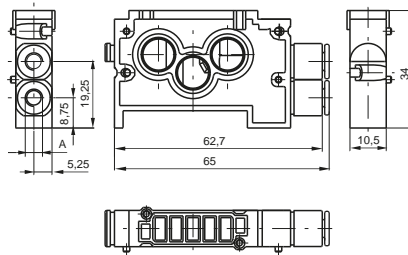

Coding: 2146.01

► Modular base for "FLAT" version



Weight 28 g

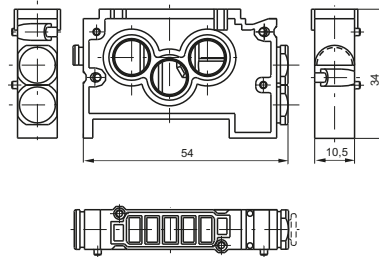

Coding: 2130.01

► Inlet base



Weight 18 g

2140.02

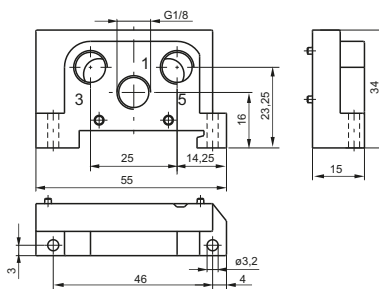

Coding: 2140.<sup>✓</sup>

VARIANTS	
<sup>✓</sup> 02	= Right
03	= Left



Weight 18 g

2140.03

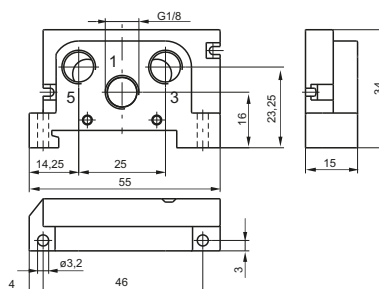

1

AIR DISTRIBUTION

► Closing plate

Coding: 2130.00

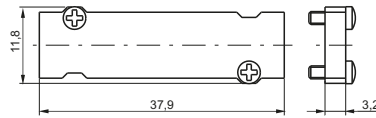

Weight 7 g

► Intermediate air intake

Coding: 2130.10

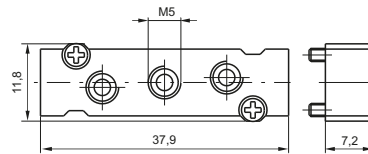

Weight 12 g  
to be assembled instead of a valve

► DIN rail adapter

Coding: 2130.16

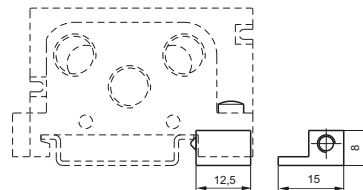

Weight 6 g

► Modular base cartridge

Coding: 2100.▼



VARIANTS	
031M	= Ø4 tube cartridge
033M	= M5 cartridges
034M	= M7x1 cartridges
035M	= Blank base
036M	= Ø4 tube cartridge

Weight 5 g

► Diaphragm plug

Coding: 2130.17



Weight 6 g



The integral electrical design for the series 2400 valve is extremely flexible, allowing the production of pre-wired solenoid valve manifolds, the configuration of which can be determined at the point of assembly. The 24 VDC, 12 VDC (equivalent PNP) modules are available with 2 or 4 positions. The system assembled is designed for an IP40 - IP65 protection.

Coil type 91 or 92 is required for the multipin electrical connection (see valve ordering codes).

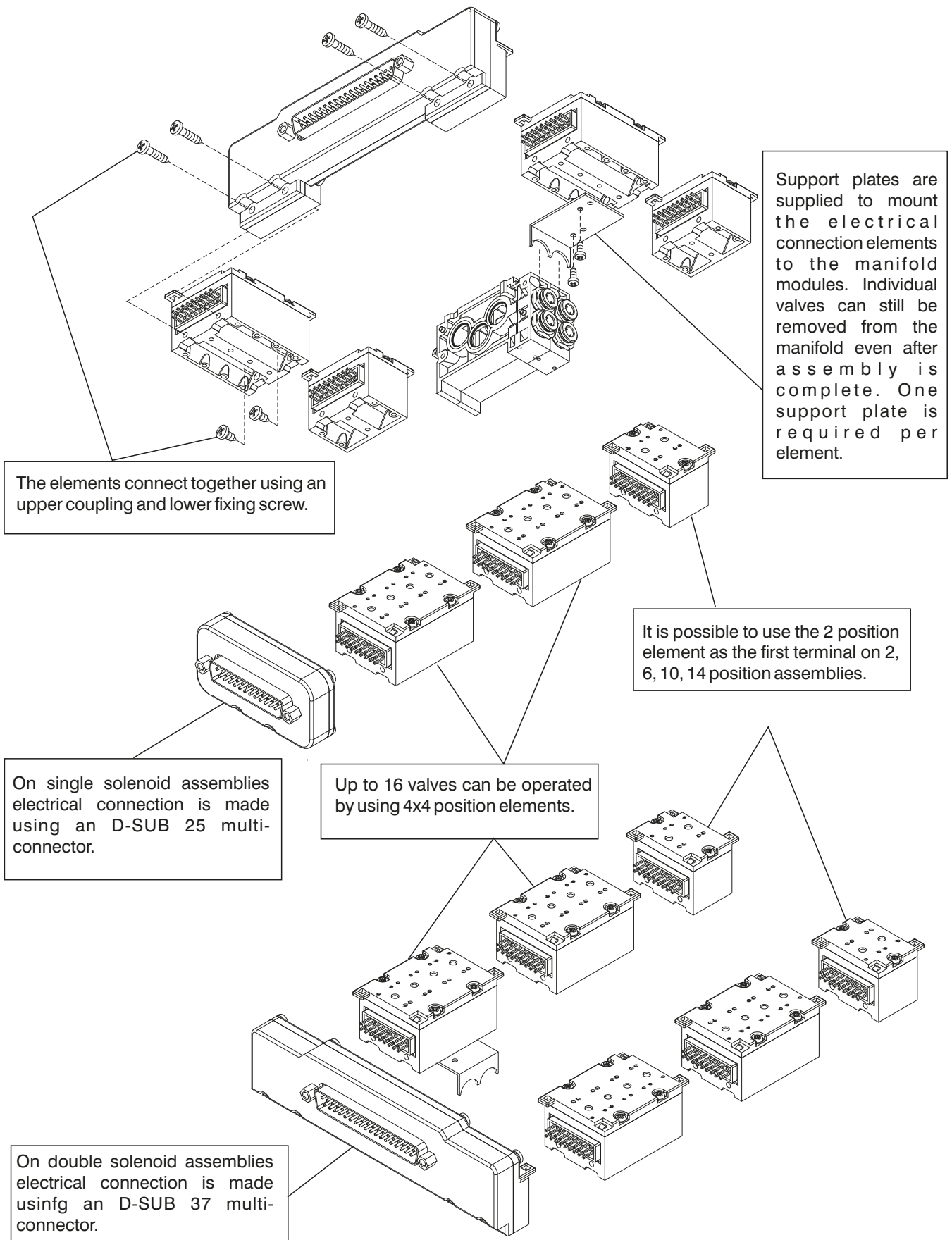

▶ **Module for connections**



Weight 35 g

2100.02.T



Weight 20 g

2100.04.T

Coding: 2100.P.T

	POSITIONS
P	04 = 4 positions
	02 = 2 positions
	TYPE
	00 = Left IP40-PNP
	02 = Left IP40-PNP with protection diode
	10 = Left IP65-PNP
	12 = Left IP65-PNP with protection diode
T	01 = Right IP40-PNP
	03 = Right IP40-PNP with protection diode
	11 = Right IP65-PNP
	13 = Right IP65-PNP with protection diode

▶ **Front connector**



Weight 120 g

The IP65 protection is obtained by IP65 Pneumax cable

2100.37.10



Weight 40 g

The IP65 protection is obtained by IP65 Pneumax cable

2100.25.10

Coding: 2100.P.10

	POLES
P	37 = 37 poles
	25 = 25 poles

▶ **Plug**



Weight 4 g

Coding: 2100.00

▶ **FLAT support plate**



Weight 5 g

Coding: 2130.50



**In line cable complete with connector IP40**



Coding: 2400.**T**.**L**.00

	CONNECTORS
<b>T</b>	25 = 25 poles 37 = 37 poles
	CABLE LENGTH
<b>L</b>	03 = 3 meters 05 = 5 meters 10 = 10 meters

**Cable complete with connector, 25 Poles IP65**



Coding: 2300.25.**L**.**C**

	CABLE LENGTH
<b>L</b>	03 = 3 meters 05 = 5 meters 10 = 10 meters
	CONNECTOR
<b>C</b>	10 = In line 90 = 90° Angle

**Cable complete with connector, 37 Poles IP65**



Coding: 2400.37.**L**.**C**

	CABLE LENGTH
<b>L</b>	03 = 3 meters 05 = 5 meters 10 = 10 meters
	CONNECTOR
<b>C</b>	10 = In line 90 = 90° Angle

1  
AIR DISTRIBUTION

**SUB-D 25 CONTACTS CONNECTOR**

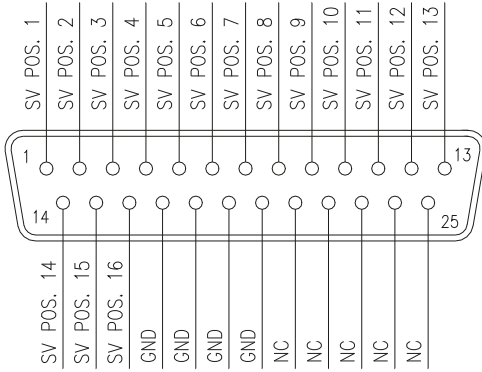

**SUB-D 37 CONTACTS CONNECTOR**

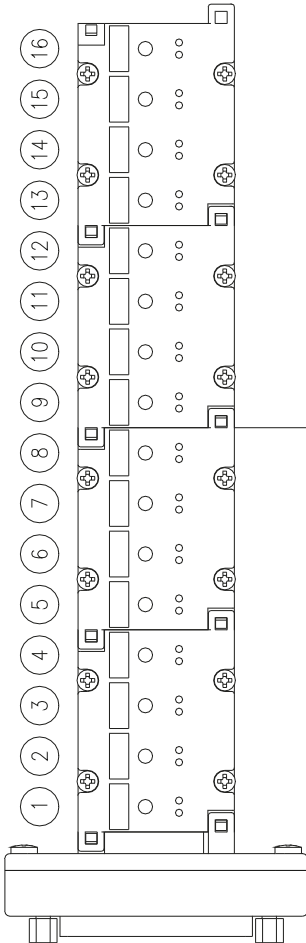
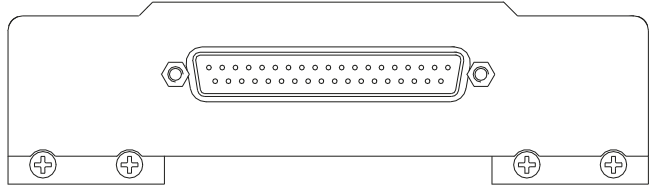
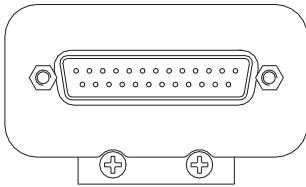
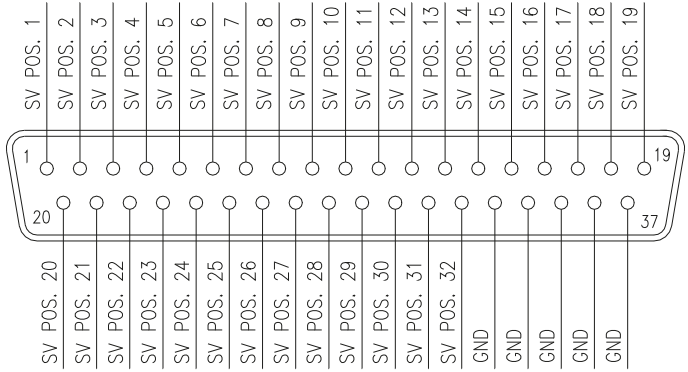

Left modules

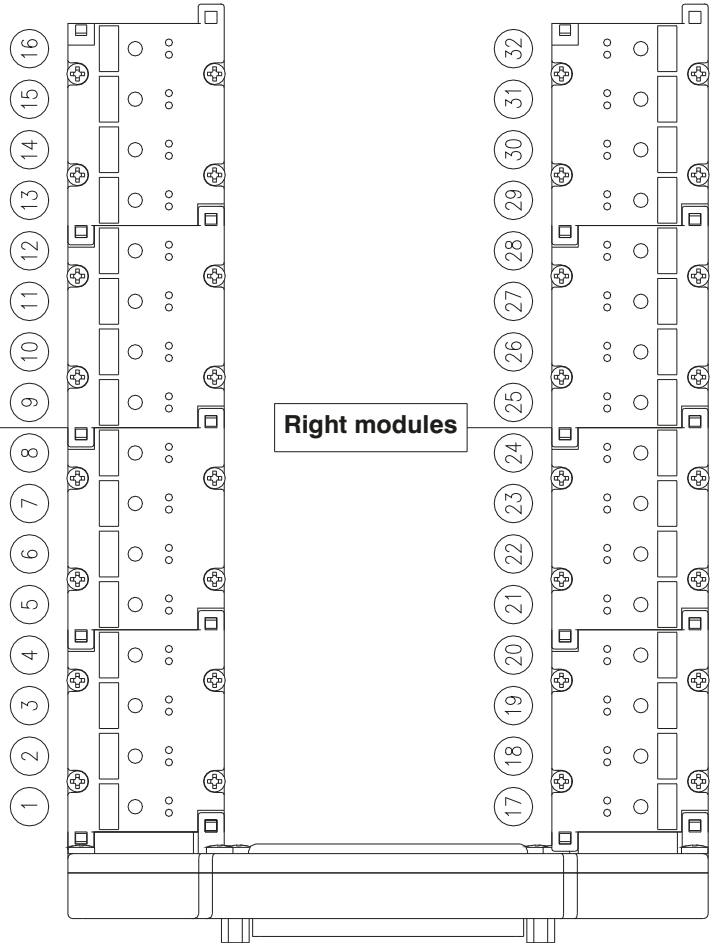

Right modules



## Series 2400

### General

This solenoid valves series has been developed to meet requirements for electronically controlled pneumatic systems and / or serial control systems already used in all manufacturing sectors.  
They have been designed to be easily assembled into groups or manifolds and include integral electrical connection to facilitate simple and speedy integration into a control system.  
The 2400 series comprises a range of products classified according to the body size of 18mm divided into 3 types "LINE", "FLAT" and "VDMA".  
The 10mm. and 18 mm. 24 VDC range of valves includes a range of accessories for the production of manifolded valve assemblies with integral electrical connections.  
Modules are available in two or four station variants for flexibility and are supplied to IP40 or alternatively IP65 environmental protection.

### Construction characteristics

Central body	Extruded aluminium bar with chemical nickel treatment and PTFE (polytetrafluorethylene)
Connection plates	Zincalloy
Operators	Technopolymer
Spool seals	Oil resistant nitrile rubber - HNBR
Spools	Aluminium 2011
Springs	AISI 302 stainless steel
Pistons	Technopolymer
Piston seals	Oil resistant nitrile rubber - NBR

### Use and maintenance

The average life of the solenoid valve exceeds 50.000.000 cycles when used under optimum conditions.  
Adequate lubrication reduces seals wear, just as proper filtering of supply air prevents the build-up of dirt that can cause malfunction.  
Ensure the valve is used within our recommended criteria for pressure and temperature.  
In dirty or dusty environments, the exhaust ports should be protected.  
A seal kit including the spool is available for overhauling the valve. This operation does not require a skilled worker, although a particular care should be taken when reassembling the valve.

### Ordering codes for miniature solenoid valves

The 15 mm. miniature solenoid valve with 1,1 mm. orifice has been selected for piloting this series of valves (see Series 300).  
This results in low response times and reduced power consumption.  
The valve can be supplied with the coil upward or downward (multipolar connections) depending on the application.

Codes are as follows:

#### Coil upward code

- 01 = miniature solenoid 12 VDC
- 02 = miniature solenoid 24 VDC
- 05 = miniature solenoid 24 VAC
- 06 = miniature solenoid 110 VAC
- 07 = miniature sol. 230 VAC
- 08 = miniature sol. 24 VDC 1W
- 09 = miniature sol. 24 VDC Earth faston

#### Coil downward code

- 11 = miniature solenoid 12 VDC
- 12 = miniature solenoid 24 VDC
- 15 = miniature solenoid 24 VAC
- 16 = miniature solenoid 110 VAC
- 17 = miniature sol. 230 VAC
- 18 = miniature sol. 24 VDC 1W Downward
- 19 = miniature sol. 24 VDC Earth faston Downward

	<b>Well-tried component</b>	<ul style="list-style-type: none"> <li>- The product is a well-tried product for a safety-related application according to ISO 13849-1.</li> <li>- The relevant basic and well-tried safety principles according ISO 13849-2 for this product are fulfilled.</li> <li>- The suitability of the product for a precise application must be verified and confirmed by the user.</li> </ul>
<b>B<sub>10d</sub></b>	50.000.000	

Miniature solenoid valves  homologated are available (see Series 300).



1  
AIR DISTRIBUTION

**Pneumatic - Spring**

Coding: 241(A).52.00.19

Operational characteristics	
Fluid	Filtered air. No lubrication needed, if applied it shall be continuous
Max working pressure (bar)	10
Maximum piloting pressure (bar)	2
Temperature °C	-5 ÷ +50
Flow rate at 6 bar with Δp=1 (NI/min)	800
Orifice size (mm)	7
Pilot ports size	M5

WORKING PORTS SIZE	
1	= G1/4"
5	= G1/8"
6	= Quick fitting tube Ø6
8	= Quick fitting tube Ø8

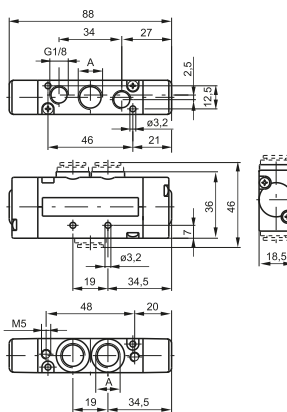

Weight 155 g

For dimension "A" see ordering code

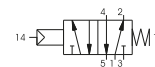

**Pneumatic - Differential**

Coding: 241(A).52.00.16

Operational characteristics	
Fluid	Filtered air. No lubrication needed, if applied it shall be continuous
Max working pressure (bar)	10
Maximum piloting pressure (bar)	2
Temperature °C	-5 ÷ +50
Flow rate at 6 bar with Δp=1 (NI/min)	800
Orifice size (mm)	7
Pilot ports size	M5

WORKING PORTS SIZE	
1	= G1/4"
5	= G1/8"
6	= Quick fitting tube Ø6
8	= Quick fitting tube Ø8

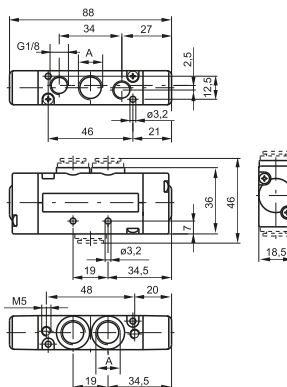

Weight 155 g

For dimension "A" see ordering code

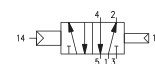



**Pneumatic - Differential (External)**

Coding: 241 **A**.52.00.17

Operational characteristics	
Fluid	Filtered air. No lubrication needed, if applied it shall be continuous
Max working pressure (bar)	10
Maximum piloting pressure (bar)	2
Temperature °C	-5 ÷ +50
Flow rate at 6 bar with Δp=1 (NI/min)	800
Orifice size (mm)	7
Pilot ports size	M5

WORKING PORTS SIZE	
<b>1</b>	= G1/4"
<b>5</b>	= G1/8"
<b>6</b>	= Quick fitting tube Ø6
<b>8</b>	= Quick fitting tube Ø8

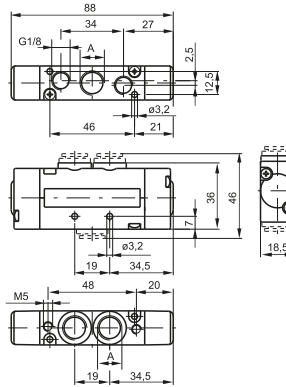

Weight 155 g

For dimension "A" see ordering code



1  
AIR DISTRIBUTION

**Pneumatic - Pneumatic**

Coding: 241 **A**.52.00.18

Operational characteristics	
Fluid	Filtered air. No lubrication needed, if applied it shall be continuous
Max working pressure (bar)	10
Maximum piloting pressure (bar)	1.5
Temperature °C	-5 ÷ +50
Flow rate at 6 bar with Δp=1 (NI/min)	800
Orifice size (mm)	7
Pilot ports size	M5

WORKING PORTS SIZE	
<b>1</b>	= G1/4"
<b>5</b>	= G1/8"
<b>6</b>	= Quick fitting tube Ø6
<b>8</b>	= Quick fitting tube Ø8

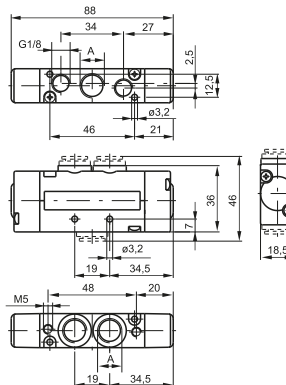

Weight 155 g

For dimension "A" see ordering code





# Spool valves and solenoid valves Series 2400 - Size 18mm LINE

## Solenoid-Spring / Differential

Coding: 241A.52.00.V.T

Operational characteristics	
Fluid	Filtered air. No lubrication needed, if applied it shall be continuous
Max working pressure (bar)	10
Maximum piloting pressure (bar)	2
Temperature °C	-5 ÷ +50
Flow rate at 6 bar with Δp=1 (NI/min)	800
Orifice size (mm)	7
Pilot ports size	M5

WORKING PORTS SIZE	
1	= G1/4"
5	= G1/8"
6	= Quick fitting tube Ø6
8	= Quick fitting tube Ø8
VERSION	
39	= Solenoid - Spring
29	= Solenoid external-Spring
36	= Solenoid-Differential
37	= Solenoid-Differential external
26	= Solenoid external-Differential
27	= Solenoid external-Differential external
VOLTAGE	
01	= 12V DC
02	= 24V DC
05	= 24V AC
06	= 110V AC
07	= 230 V AC
08	= 24V DC 1W
09	= 24V DC downward
11	= 12V DC downward
12	= 24V DC downward
15	= 24V AC downward
16	= 110V AC downward
17	= 230 V AC downward
18	= 24V DC 1W downward
19	= 24V DC Earth faston downward

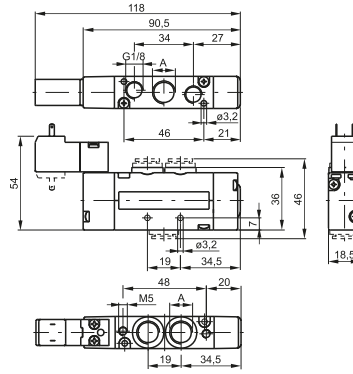

For dimension "A" see ordering code

Weight 195 g

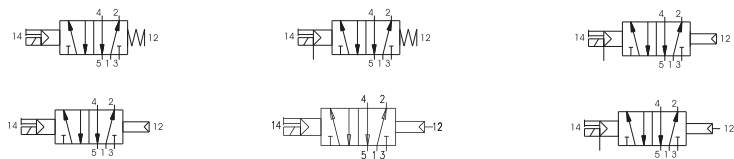

## Solenoid - Solenoid

Coding: 241A.52.00.V.T

Operational characteristics	
Fluid	Filtered air. No lubrication needed, if applied it shall be continuous
Max working pressure (bar)	10
Maximum piloting pressure (bar)	1.5
Temperature °C	-5 ÷ +50
Flow rate at 6 bar with Δp=1 (NI/min)	800
Orifice size (mm)	7
Pilot ports size	M5

WORKING PORTS SIZE	
1	= G1/4"
5	= G1/8"
6	= Quick fitting tube Ø6
8	= Quick fitting tube Ø8
VERSION	
35	= Solenoid-Solenoid
24	= Solenoid external-Solenoid external
VOLTAGE	
01	= 12V DC
02	= 24V DC
05	= 24V AC
06	= 110V AC
07	= 230 V AC
08	= 24V DC 1W
09	= 24V DC downward
11	= 12V DC downward
12	= 24V DC downward
15	= 24V AC downward
16	= 110V AC downward
17	= 230 V AC downward
18	= 24V DC 1W downward
19	= 24V DC Earth faston downward

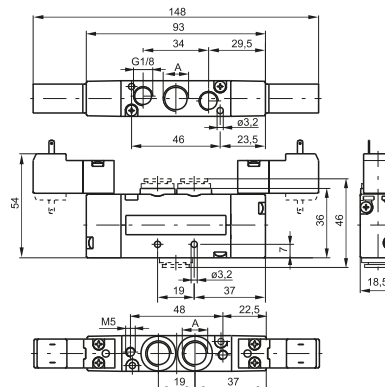

For dimension "A" see ordering code

Weight 225 g

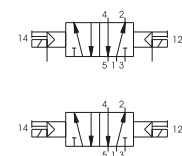

AIR DISTRIBUTION 1

**Pneumatic-Pneumatic 5/3**

Coding: 241 **A**.53.**F**.18

Operational characteristics	
Fluid	Filtered air. No lubrication needed, if applied it shall be continuous
Max working pressure (bar)	10
Maximum piloting pressure (bar)	3
Temperature °C	-5 ÷ +50
Flow rate at 6 bar with Δp=1 (NI/min)	650
Orifice size (mm)	7
Pilot ports size	M5

WORKING PORTS SIZE	
<b>1</b>	= G1/4"
<b>5</b>	= G1/8"
<b>6</b>	= Quick fitting tube Ø6
<b>8</b>	= Quick fitting tube Ø8
CONNECTOR	
<b>10</b>	= In line
<b>90</b>	= 90° Angle

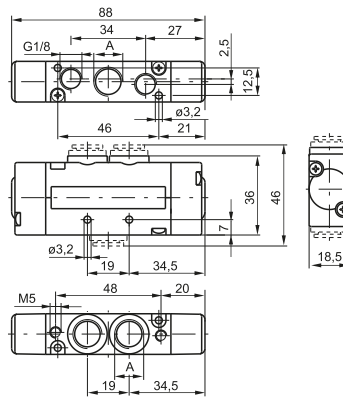

Weight 165 g

For dimension "A" see ordering code

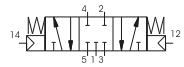
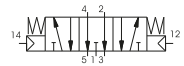
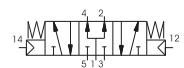

**Solenoid - Solenoid**

Coding: 241 **A**.53.**F**.**V**.**T**

Operational characteristics	
Fluid	Filtered air. No lubrication needed, if applied it shall be continuous
Max working pressure (bar)	10
Maximum piloting pressure (bar)	3
Temperature °C	-5 ÷ +50
Flow rate at 6 bar with Δp=1 (NI/min)	650
Orifice size (mm)	7
Pilot ports size	M5

WORKING PORTS SIZE	
<b>1</b>	= G1/4"
<b>5</b>	= G1/8"
<b>6</b>	= Quick fitting tube Ø6
<b>8</b>	= Quick fitting tube Ø8
FUNCTION	
<b>31</b>	= Closed centres
<b>32</b>	= Open centres
<b>33</b>	= Pressured centres
VERSION	
<b>24</b>	= Solenoid external-Solenoid external
<b>35</b>	= Solenoid-Solenoid
VOLTAGE	
<b>01</b>	= 12V DC
<b>02</b>	= 24V DC
<b>05</b>	= 24V AC
<b>06</b>	= 110V AC
<b>07</b>	= 230 V AC
<b>08</b>	= 24V DC 1W
<b>09</b>	= 24V DC downward
<b>11</b>	= 12V DC downward
<b>12</b>	= 24V DC downward
<b>15</b>	= 24V AC downward
<b>16</b>	= 110V AC downward
<b>17</b>	= 230 V AC downward
<b>18</b>	= 24V DC 1W downward
<b>19</b>	= 24V DC Earth faston downward

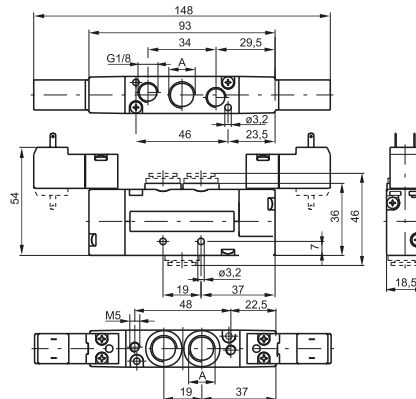

Weight 235 g

For dimension "A" see ordering code

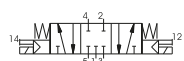
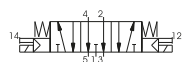
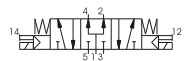



# Spool valves and solenoid valves Series 2400 - Size 18mm LINE

## Pneumatic-Pneumatic 2 x 3/2

Coding: 241 **A**. 62. **F**. 18

Operational characteristics	
Fluid	Filtered air. No lubrication needed, if applied it shall be continuous
Max working pressure (bar)	10
Maximum piloting pressure (bar)	$\geq 1,5 + (0,2 \times \text{Inlet pressure})$
Temperature °C	-5 ÷ +50
Flow rate at 6 bar with $\Delta p=1$ (NI/min)	450
Orifice size (mm)	7

Example: if inlet pressure is set at 5bar then pilot pressure must be at least  $Pp = 1,5 + (0,2 \times 5) = 2,5 \text{ bar}$

WORKING PORTS SIZE	
<b>1</b>	= G1/4"
<b>5</b>	= G1/8"
<b>6</b>	= Quick fitting tube $\varnothing 6$
<b>8</b>	= Quick fitting tube $\varnothing 8$
FUNCTION	
<b>44</b>	= 2 Coils 3/2 NC
<b>45</b>	= 1 Coil 3/2 NC (14) + 1 Coil 3/2
<b>F</b> NO (12)	
<b>55</b>	= 2 Coils 3/2 NO
<b>54</b>	= 1 Coil 3/2 NO (14) + 1 Coil 3/2 NC (12)

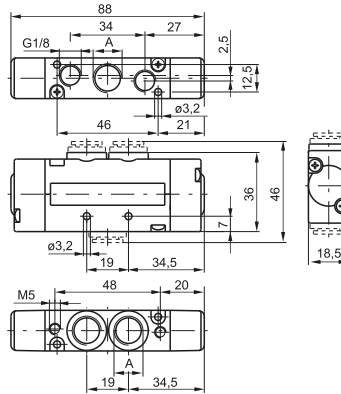

For dimension "A" see ordering code

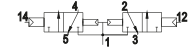
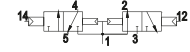
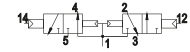
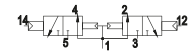

Weight 170 g

## Solenoid - Solenoid 2 x 3/2

Coding: 241 **A**. 62. **F**. 35. **T**

Operational characteristics	
Fluid	Filtered air. No lubrication needed, if applied it shall be continuous
Max working pressure (bar)	10
Maximum piloting pressure (bar)	$\geq 1,5 + (0,2 \times \text{Inlet pressure})$
Temperature °C	-5 ÷ +50
Flow rate at 6 bar with $\Delta p=1$ (NI/min)	450
Orifice size (mm)	7

Example: if inlet pressure is set at 5bar then pilot pressure must be at least  $Pp = 1,5 + (0,2 \times 5) = 2,5 \text{ bar}$

WORKING PORTS SIZE	
<b>1</b>	= G1/4"
<b>5</b>	= G1/8"
<b>6</b>	= Quick fitting tube $\varnothing 6$
<b>8</b>	= Quick fitting tube $\varnothing 8$
FUNCTION	
<b>44</b>	= 2 Coils 3/2 NC
<b>45</b>	= 1 Coil 3/2 NC (14) + 1 Coil 3/2
<b>F</b> NO (12)	
<b>55</b>	= 2 Coils 3/2 NO
<b>54</b>	= 1 Coil 3/2 NO (14) + 1 Coil 3/2 NC (12)
VOLTAGE	
<b>01</b>	= 12V DC
<b>02</b>	= 24V DC
<b>05</b>	= 24V AC
<b>06</b>	= 110V AC
<b>07</b>	= 230 V AC
<b>08</b>	= 24V DC 1 Watt
<b>T</b> 09	= 24V DC downward
<b>11</b>	= 12V DC downward
<b>12</b>	= 24V DC downward
<b>15</b>	= 24V AC downward
<b>16</b>	= 110V AC downward
<b>17</b>	= 230 V AC downward
<b>18</b>	= 24V DC 1 Watt downward
<b>19</b>	= 24V DC Earth faston downward

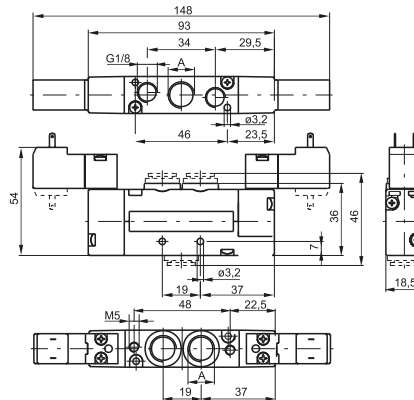

For dimension "A" see ordering code

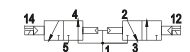
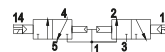
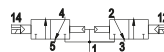
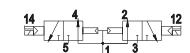

Weight 250 g

**Pneumatic - Spring**

Coding: 243 **A**.52.00.19

Operational characteristics	
Fluid	Filtered air. No lubrication needed, if applied it shall be continuous
Max working pressure (bar)	10
Maximum piloting pressure (bar)	2
Temperature °C	-5 ÷ +50
Flow rate at 6 bar with Δp=1 (NI/min)	800
Orifice size (mm)	7
Pilot ports size	M5

WORKING PORTS SIZE	
<b>1</b>	= G1/4"
<b>5</b>	= G1/8"
<b>6</b>	= Quick fitting tube Ø6
<b>8</b>	= Quick fitting tube Ø8



Weight 105 g

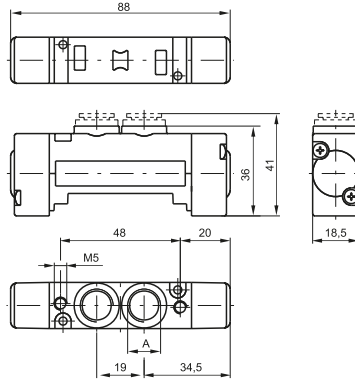

For dimension "A" see ordering code

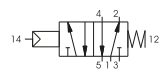

**Pneumatic - Differential**

Coding: 243 **A**.52.00.16

Operational characteristics	
Fluid	Filtered air. No lubrication needed, if applied it shall be continuous
Max working pressure (bar)	10
Maximum piloting pressure (bar)	2
Temperature °C	-5 ÷ +50
Flow rate at 6 bar with Δp=1 (NI/min)	800
Orifice size (mm)	7
Pilot ports size	M5

WORKING PORTS SIZE	
<b>1</b>	= G1/4"
<b>5</b>	= G1/8"
<b>6</b>	= Quick fitting tube Ø6
<b>8</b>	= Quick fitting tube Ø8



Weight 105 g

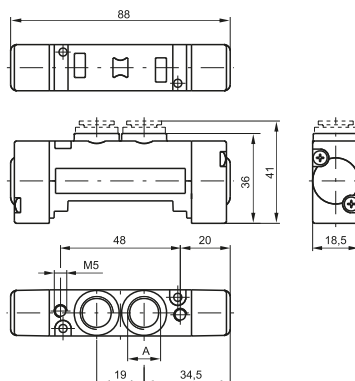

For dimension "A" see ordering code

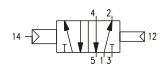

**Pneumatic - Differential (External)**

Coding: 243 **A**.52.00.17

Operational characteristics	
Fluid	Filtered air. No lubrication needed, if applied it shall be continuous
Max working pressure (bar)	10
Maximum piloting pressure (bar)	2
Temperature °C	-5 ÷ +50
Flow rate at 6 bar with Δp=1 (NI/min)	800
Orifice size (mm)	7
Pilot ports size	M5

WORKING PORTS SIZE	
<b>1</b>	= G1/4"
<b>5</b>	= G1/8"
<b>6</b>	= Quick fitting tube Ø6
<b>8</b>	= Quick fitting tube Ø8



Weight 105 g

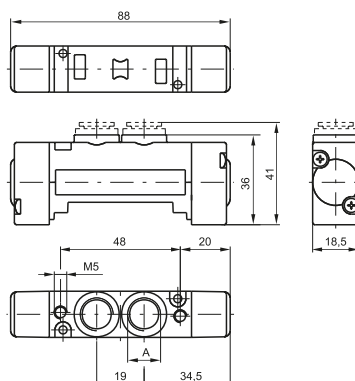

For dimension "A" see ordering code

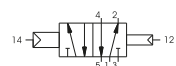



# Spool valves and solenoid valves Series 2400 - Size 18mm FLAT

## Pneumatic - Pneumatic

Coding: 243<sup>A</sup>.52.00.18

Operational characteristics	
Fluid	Filtered air. No lubrication needed, if applied it shall be continuous
Max working pressure (bar)	10
Maximum piloting pressure (bar)	1,5
Temperature °C	-5 ÷ +50
Flow rate at 6 bar with Δp=1 (NI/min)	800
Orifice size (mm)	7
Pilot ports size	M5

WORKING PORTS SIZE	
1	= G1/4"
5	= G1/8"
6	= Quick fitting tube Ø6
8	= Quick fitting tube Ø8

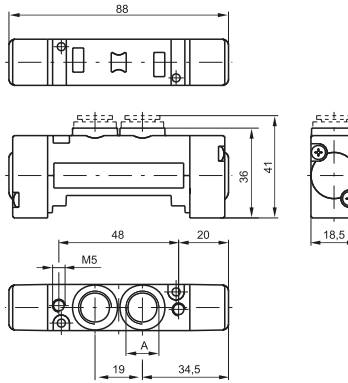

Weight 105 g

For dimension "A" see ordering code

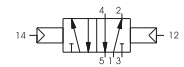

## Solenoid-Spring / Differential

Coding: 243<sup>A</sup>.52.00.<sup>V</sup>.<sup>T</sup>

Operational characteristics	
Fluid	Filtered air. No lubrication needed, if applied it shall be continuous
Max working pressure (bar)	10
Maximum piloting pressure (bar)	2
Temperature °C	-5 ÷ +50
Flow rate at 6 bar with Δp=1 (NI/min)	800
Orifice size (mm)	7
Pilot ports size	M5

WORKING PORTS SIZE	
1	= G1/4"
5	= G1/8"
6	= Quick fitting tube Ø6
8	= Quick fitting tube Ø8
VERSION	
39	= Solenoid - Spring
29	= Solenoid external-Spring
36	= Solenoid-Differential
37	= Solenoid-Differential external
26	= Solenoid external-Differential
27	= Solenoid external-Differential external
VOLTAGE	
01	= 12V DC
02	= 24V DC
05	= 24V AC
06	= 110V AC
07	= 230 V AC
08	= 24V DC 1W
09	= 24V DC downward
11	= 12V DC downward
12	= 24V DC downward
15	= 24V AC downward
16	= 110V AC downward
17	= 230 V AC downward
18	= 24V DC 1W downward
19	= 24V DC Earth faston downward

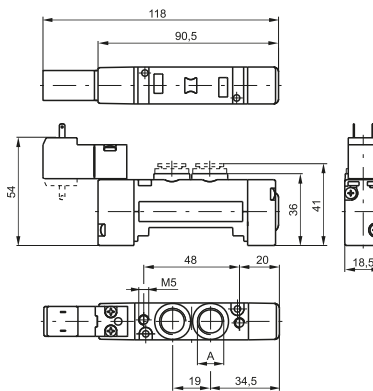

For dimension "A" see ordering code

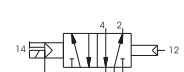
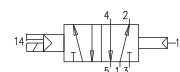
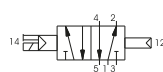
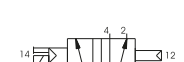
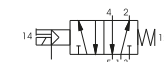

Weight 140 g

AIR DISTRIBUTION

**Solenoid - Solenoid**

Coding: 243 **A**.52.00. **V**. **T**

Operational characteristics	
Fluid	Filtered air. No lubrication needed, if applied it shall be continuous
Max working pressure (bar)	10
Maximum piloting pressure (bar)	1.5
Temperature °C	-5 ÷ +50
Flow rate at 6 bar with Δp=1 (NI/min)	800
Orifice size (mm)	7
Pilot ports size	M5

WORKING PORTS SIZE	
<b>1</b>	= G1/4"
<b>5</b>	= G1/8"
<b>6</b>	= Quick fitting tube Ø6
<b>8</b>	= Quick fitting tube Ø8
VERSION	
<b>35</b>	= Solenoid-Solenoid
<b>24</b>	= Solenoid external-Solenoid external
VOLTAGE	
<b>01</b>	= 12V DC
<b>02</b>	= 24V DC
<b>05</b>	= 24V AC
<b>06</b>	= 110V AC
<b>07</b>	= 230 V AC
<b>08</b>	= 24V DC 1W
<b>09</b>	= 24V DC downward
<b>11</b>	= 12V DC downward
<b>12</b>	= 24V DC downward
<b>15</b>	= 24V AC downward
<b>16</b>	= 110V AC downward
<b>17</b>	= 230 V AC downward
<b>18</b>	= 24V DC 1W downward
<b>19</b>	= 24V DC Earth faston downward

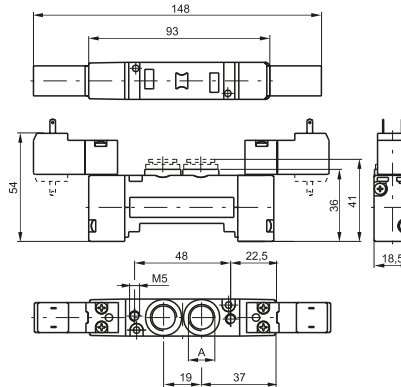

Weight 175 g

For dimension "A" see ordering code

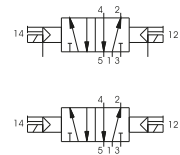

1  
AIR DISTRIBUTION

**Pneumatic - Pneumatic 5 ways 3 connections**

Coding: 243 **A**.53. **F**.18

Operational characteristics	
Fluid	Filtered air. No lubrication needed, if applied it shall be continuous
Max working pressure (bar)	10
Maximum piloting pressure (bar)	3
Temperature °C	-5 ÷ +50
Flow rate at 6 bar with Δp=1 (NI/min)	650
Orifice size (mm)	7
Pilot ports size	M5

WORKING PORTS SIZE	
<b>1</b>	= G1/4"
<b>5</b>	= G1/8"
<b>6</b>	= Quick fitting tube Ø6
<b>8</b>	= Quick fitting tube Ø8
FUNCTION	
<b>31</b>	= Closed centres
<b>32</b>	= Open centres
<b>33</b>	= Pressured centres

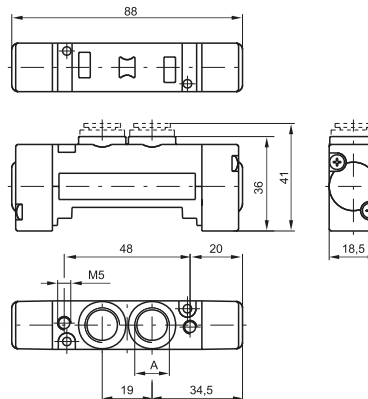

Weight 115 g

For dimension "A" see ordering code

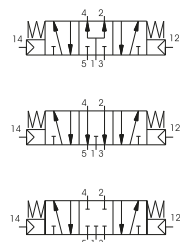



# Spool valves and solenoid valves Series 2400 - Size 18mm FLAT

1  
AIR DISTRIBUTION

## Solenoid - Solenoid 5/3

Coding: 243A.53.F.V.T

Operational characteristics	
Fluid	Filtered air. No lubrication needed, if applied it shall be continuous
Max working pressure (bar)	10
Maximum piloting pressure (bar)	3
Temperature °C	-5 ÷ +50
Flow rate at 6 bar with Δp=1 (NI/min)	650
Orifice size (mm)	7
Pilot ports size	M5

WORKING PORTS SIZE	
1	= G1/4"
5	= G1/8"
6	= Quick fitting tube Ø6
8	= Quick fitting tube Ø8
FUNCTION	
31	= Closed centres
32	= Open centres
33	= Pressured centres
VERSION	
24	= Solenoid external-Solenoid external
35	= Solenoid-Solenoid
VOLTAGE	
01	= 12V DC
02	= 24V DC
05	= 24V AC
06	= 110V AC
07	= 230 V AC
08	= 24V DC 1W
09	= 24V DC downward
11	= 12V DC downward
12	= 24V DC downward
15	= 24V AC downward
16	= 110V AC downward
17	= 230 V AC downward
18	= 24V DC 1W downward
19	= 24V DC Earth faston downward

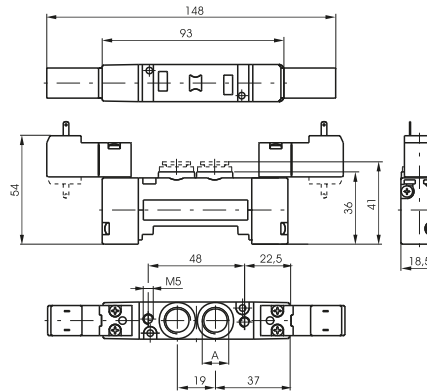

Weight 185 g

For dimension "A" see ordering code

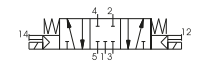
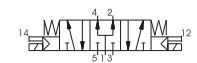

## Pneumatic-Pneumatic 2 x 3/2

Coding: 243A.62.F.18

Operational characteristics	
Fluid	Filtered air. No lubrication needed, if applied it shall be continuous
Max working pressure (bar)	10
Maximum piloting pressure (bar)	≥ 1,5 + (0,2 x Inlet pressure)
Temperature °C	-5 ÷ +50
Flow rate at 6 bar with Δp=1 (NI/min)	450
Orifice size (mm)	7

WORKING PORTS SIZE	
1	= G1/4"
5	= G1/8"
6	= Quick fitting tube Ø6
8	= Quick fitting tube Ø8
FUNCTION	
44	= 2 Coils 3/2 NC
45	= 1 Coil 3/2 NC (14) + 1 Coil 3/2 NO (12)
55	= 2 Coils 3/2 NO
54	= 1 Coil 3/2 NO (14) + 1 Coil 3/2 NC (12)

Example: if inlet pressure is set at 5bar then pilot pressure must be at least  $P_p = 1,5 + (0,2 * 5) = 2,5$  bar

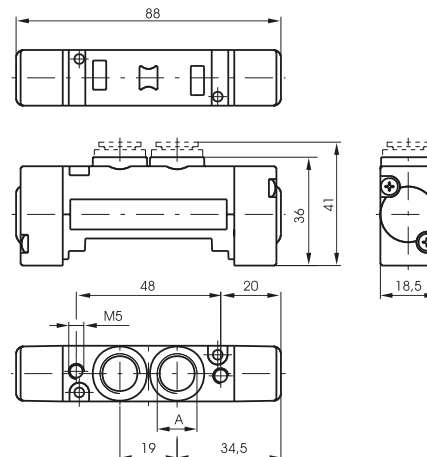

Weight 110 g

For dimension "A" see ordering code

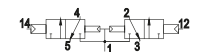
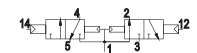
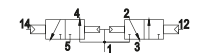
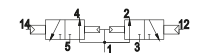





**Solenoid - Solenoid 2 x 3/2**

Coding: 243 **A**.62. **F**.35. **T**

Operational characteristics	
Fluid	Filtered air. No lubrication needed, if applied it shall be continuous
Max working pressure (bar)	10
Maximum piloting pressure (bar)	$\geq 1,5 + (0,2 \times \text{Inlet pressure})$
Temperature °C	-5 ÷ +50
Flow rate at 6 bar with $\Delta p = 1$ (l/min)	450
Orifice size (mm)	7

Example: if inlet pressure is set at 5bar then pilot pressure must be at least  $P_p = 1,5 + (0,2 \times 5) = 2,5 \text{ bar}$

WORKING PORTS SIZE	
<b>1</b>	= G1/4"
<b>5</b>	= G1/8"
<b>6</b>	= Quick fitting tube Ø6
<b>8</b>	= Quick fitting tube Ø8
FUNCTION	
<b>44</b>	= 2 Coils 3/2 NC
<b>45</b>	= 1 Coil 3/2 NC (14) + 1 Coil 3/2 NO (12)
<b>55</b>	= 2 Coils 3/2 NO
<b>54</b>	= 1 Coil 3/2 NO (14) + 1 Coil 3/2 NC (12)
VOLTAGE	
<b>01</b>	= 12V DC
<b>02</b>	= 24V DC
<b>05</b>	= 24V AC
<b>06</b>	= 110V AC
<b>07</b>	= 230 V AC
<b>08</b>	= 24V DC 1 Watt
<b>09</b>	= 24V DC downward
<b>11</b>	= 12V DC downward
<b>12</b>	= 24V DC downward
<b>15</b>	= 24V AC downward
<b>16</b>	= 110V AC downward
<b>17</b>	= 230 V AC downward
<b>18</b>	= 24V DC 1 Watt downward
<b>19</b>	= 24V DC Earth faston downward

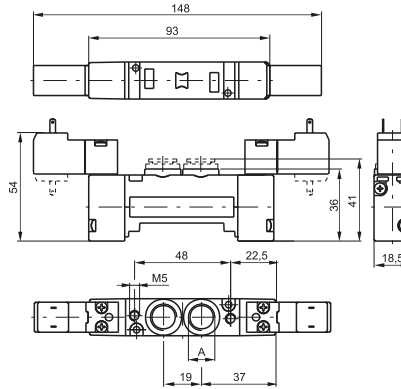

Weight 190 g

For dimension 'A' see ordering code

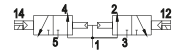
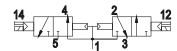
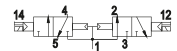
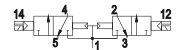

1  
AIR DISTRIBUTION

▶ **Modular base**



Weight 85 g

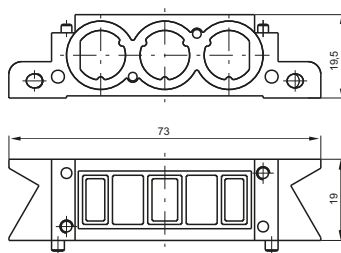

Coding: 2430.▼

VERSION	
01	Modular base
▼ 06	Supply and exhaust closed
07	Supply closed
08	Exhaust closed

▶ **Blank base**

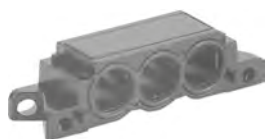

Weight 85 g

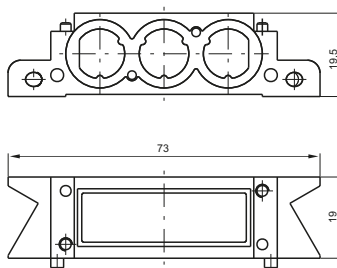

Coding: 2430.05

▶ **Inlet base**



Coding: 2430.▼

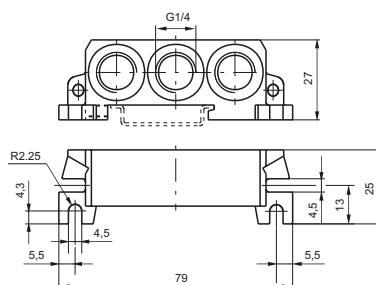

VERSION	
▼ 02	Right
03	Left

Weight 120 g

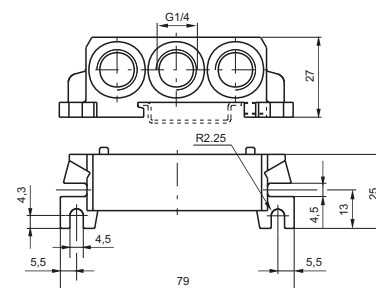

Weight 125 g

▶ **Intermediate air intake**



Weight 30 g  
to be assembled instead of a valve

Coding: 2430.10

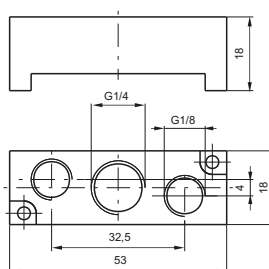



► Closing plate

Coding: 2430.00

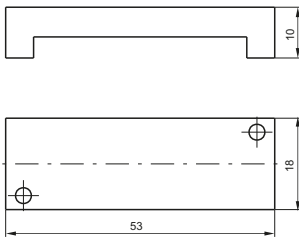

Weight 20 g

► Diaphragm plug

Coding: 2430.17



Weight 5 g



1  
AIR DISTRIBUTION

**Pneumatic - Spring**

Coding: 2445.52.00.19

**Operational characteristics**

Fluid	Filtered air. No lubrication needed, if applied it shall be continuous
Max working pressure (bar)	10
Pressure range (bar)	2
Temperature °C	-5 ÷ +50
Flow rate at 6 bar with Δp=1 (NI/min)	550
Orifice size (mm)	5



Weight 155 g

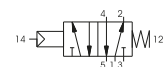
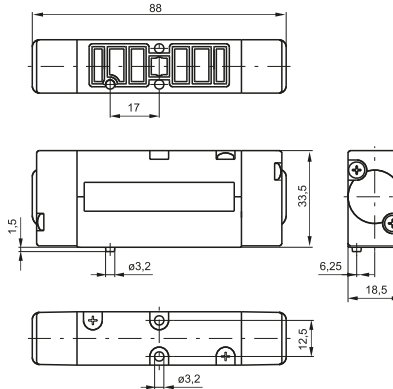

**Pneumatic - Differential**

Coding: 2445.52.00.16

**Operational characteristics**

Fluid	Filtered air. No lubrication needed, if applied it shall be continuous
Max working pressure (bar)	10
Maximum piloting pressure (bar)	2
Temperature °C	-5 ÷ +50
Flow rate at 6 bar with Δp=1 (NI/min)	550
Orifice size (mm)	5



Weight 155 g

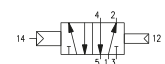
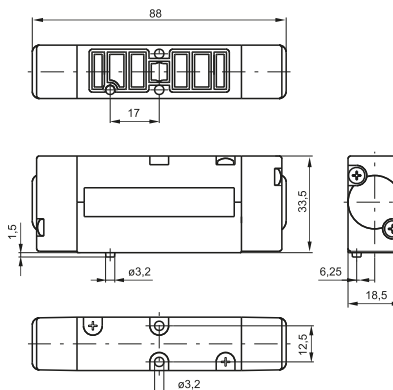

**Pneumatic - Differential (External)**

Coding: 2445.52.00.17

**Operational characteristics**

Fluid	Filtered air. No lubrication needed, if applied it shall be continuous
Max working pressure (bar)	10
Maximum piloting pressure (bar)	2
Temperature °C	-5 ÷ +50
Flow rate at 6 bar with Δp=1 (NI/min)	550
Orifice size (mm)	5



Weight 155 g

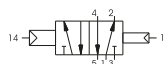
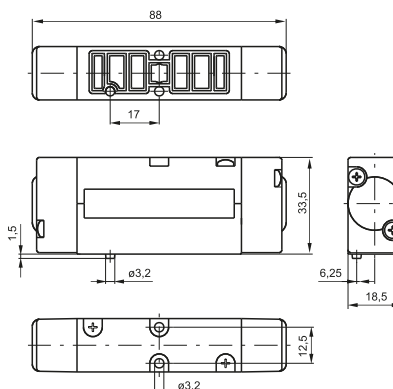

**Pneumatic - Pneumatic**

Coding: 2445.52.00.18

Operational characteristics	
Fluid	Filtered air. No lubrication needed, if applied it shall be continuous
Max working pressure (bar)	10
Maximum piloting pressure (bar)	1.5
Temperature °C	-5 ÷ +50
Flow rate at 6 bar with $\Delta p=1$ (NI/min)	550
Orifice size (mm)	5



Weight 155 g

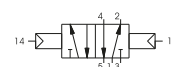
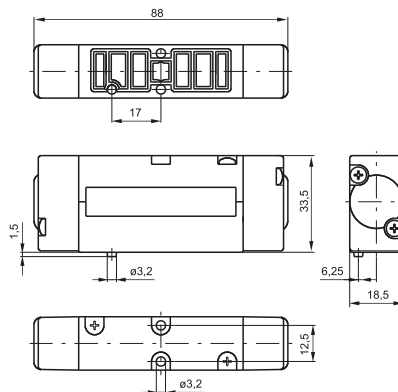

1  
AIR DISTRIBUTION



AIR DISTRIBUTION

**Solenoid-Spring / Differential**

Coding: 244C.52.00.V.T

Operational characteristics	
Fluid	Filtered air. No lubrication needed, if applied it shall be continuous
Max working pressure (bar)	10
Maximum piloting pressure (bar)	2
Temperature °C	-5 ÷ +50
Flow rate at 6 bar with Δp=1 (NI/min)	550
Orifice size (mm)	5

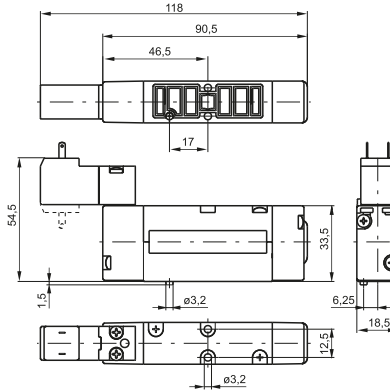

C	TYPE ELECTROPILOT EXHAUST
	1 = on base (only for self feeding valves)
	5 = on pilot (for all version)
V	VERSION
	39 = Solenoid - Spring
	29 = Solenoid external-Spring
	36 = Solenoid-Differential
	37 = Solenoid-Differential external
T	VOLTAGE
	01 = 12V DC
	02 = 24V DC
	05 = 24V AC
	06 = 110V AC
	07 = 230 V AC
	08 = 24V DC 1W
	09 = 24V DC downward
	11 = 12V DC downward
	12 = 24V DC downward
15 = 24V AC downward	
16 = 110V AC downward	
17 = 230 V AC downward	
18 = 24V DC 1W downward	
19 = 24V DC Earth faston downward	

Weight 190 g

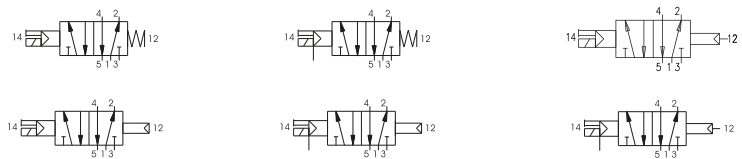

**Solenoid - Solenoid**

Coding: 244C.52.00.V.T

Operational characteristics	
Fluid	Filtered air. No lubrication needed, if applied it shall be continuous
Max working pressure (bar)	10
Maximum piloting pressure (bar)	1.5
Temperature °C	-5 ÷ +50
Flow rate at 6 bar with Δp=1 (NI/min)	550
Orifice size (mm)	5

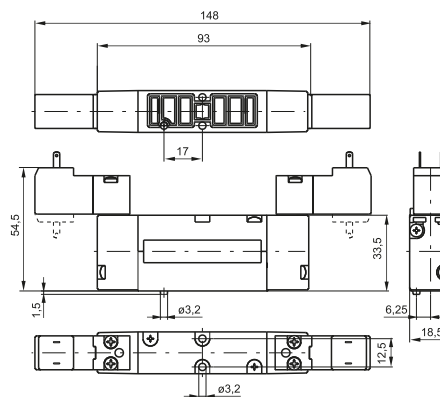

C	TYPE ELECTROPILOT EXHAUST
	1 = on base (only for self feeding valves)
	5 = on pilot (for all version)
V	VERSION
	24 = Solenoid external-Solenoid external
	35 = Solenoid-Solenoid
T	VOLTAGE
	01 = 12V DC
	02 = 24V DC
	05 = 24V AC
	06 = 110V AC
	07 = 230 V AC
	08 = 24V DC 1W
	09 = 24V DC downward
	11 = 12V DC downward
	12 = 24V DC downward
15 = 24V AC downward	
16 = 110V AC downward	
17 = 230 V AC downward	
18 = 24V DC 1W downward	
19 = 24V DC Earth faston downward	

Weight 225 g

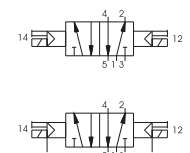

**Pneumatic - Pneumatic 5 ways 3 connections**

Coding: 244 **C**.53. **F**.18

Operational characteristics	
Fluid	Filtered air. No lubrication needed, if applied it shall be continuous
Max working pressure (bar)	10
Maximum piloting pressure (bar)	3
Temperature °C	-5 ÷ +50
Flow rate at 6 bar with Δp=1 (NI/min)	550
Orifice size (mm)	5

<b>C</b>	TYPE ELECTROPILOT EXHAUST 1 = on base (only for self feeding valves) 5 = on pilot (for all version)
<b>F</b>	FUNCTION 31 = Closed centres 32 = Open centres 33 = Pressured centres

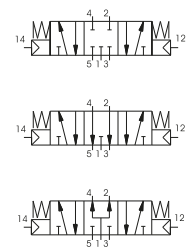
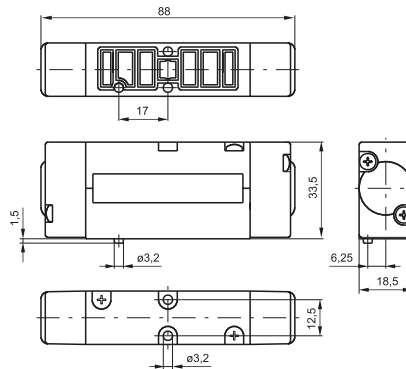

Weight 165 g

**Solenoid - Solenoid 5 ways 3 connections**

Coding: 244 **C**.53. **F**.**V**.**T**

Operational characteristics	
Fluid	Filtered air. No lubrication needed, if applied it shall be continuous
Max working pressure (bar)	10
Maximum piloting pressure (bar)	3
Temperature °C	-5 ÷ +50
Flow rate at 6 bar with Δp=1 (NI/min)	550
Orifice size (mm)	5

<b>C</b>	TYPE ELECTROPILOT EXHAUST 1 = on base (only for self feeding valves) 5 = on pilot (for all version)
<b>F</b>	FUNCTION 31 = Closed centres 32 = Open centres 33 = Pressured centres
<b>V</b>	VERSION 24 = Solenoid external-Solenoid external 35 = Solenoid-Solenoid
<b>T</b>	VOLTAGE 01 = 12V DC 02 = 24V DC 05 = 24V AC 06 = 110V AC 07 = 230 V AC 08 = 24V DC 1W 09 = 24V DC downward 11 = 12V DC downward 12 = 24V DC downward 15 = 24V AC downward 16 = 110V AC downward 17 = 230 V AC downward 18 = 24V DC 1W downward 19 = 24V DC Earth faston downward

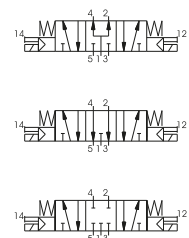
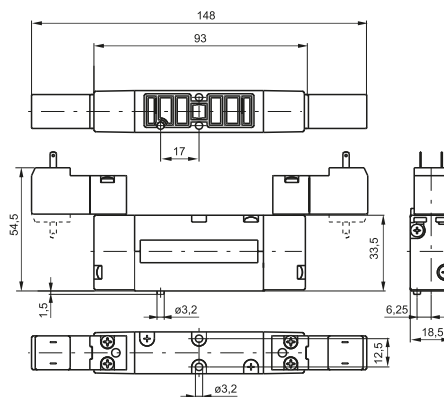

Weight 235 g

1  
AIR DISTRIBUTION



# Spool valves and solenoid valves Series 2400 - Size 18mm VDMA

## Pneumatic-Pneumatic 2 x 3/2

Coding: 2445.62.Ⓕ.18

Operational characteristics	
Fluid	Filtered air. No lubrication needed, if applied it shall be continuous
Max working pressure (bar)	10
Maximum piloting pressure (bar)	$\geq 1,5 + (0,2 \times \text{Inlet pressure})$
Temperature °C	-5 ÷ +50
Flow rate at 6 bar with $\Delta p=1$ (NI/min)	450
Orifice size (mm)	5

FUNCTION	
44	= 2 Coils 3/2 NC
45	= 1 Coil 3/2 NC (14) + 1 Coil 3/2 NO (12)
55	= 2 Coils 3/2 NO
54	= 1 Coil 3/2 NO (14) + 1 Coil 3/2 NC (12)

Example: if inlet pressure is set at 5bar then pilot pressure must be at least  $P_p = 1,5 + (0,2 \times 5) = 2,5 \text{ bar}$

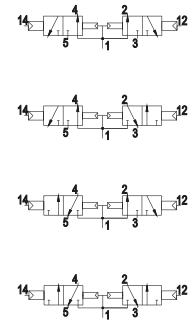
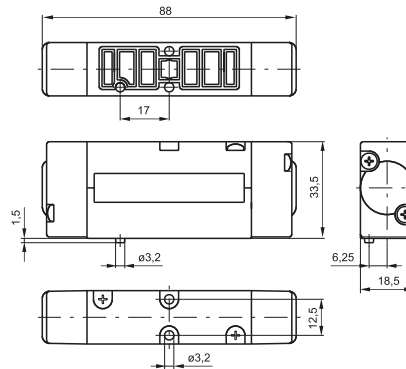

Weight 170 g

## Solenoid - Solenoid 2 x 3/2

Coding: 2445.62.Ⓕ.35.Ⓘ

Operational characteristics	
Fluid	Filtered air. No lubrication needed, if applied it shall be continuous
Max working pressure (bar)	10
Maximum piloting pressure (bar)	$\geq 1,5 + (0,2 \times \text{Inlet pressure})$
Temperature °C	-5 ÷ +50
Flow rate at 6 bar with $\Delta p=1$ (NI/min)	450
Orifice size (mm)	5

FUNCTION	
44	= 2 Coils 3/2 NC
45	= 1 Coil 3/2 NC (14) + 1 Coil 3/2 NO (12)
55	= 2 Coils 3/2 NO
54	= 1 Coil 3/2 NO (14) + 1 Coil 3/2 NC (12)

Example: if inlet pressure is set at 5bar then pilot pressure must be at least  $P_p = 1,5 + (0,2 \times 5) = 2,5 \text{ bar}$

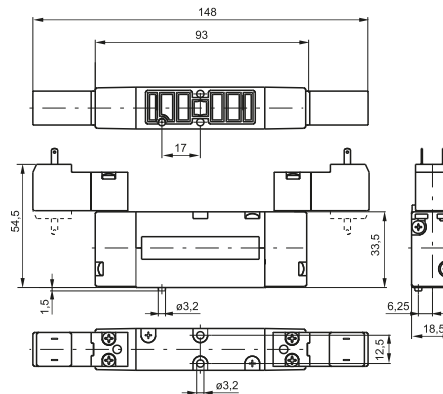

VOLTAGE	
01	= 12V DC
02	= 24V DC
05	= 24V AC
06	= 110V AC
07	= 230 V AC
08	= 24V DC 1 Watt
09	= 24V DC downward
11	= 12V DC downward
12	= 24V DC downward
15	= 24V AC downward
16	= 110V AC downward
17	= 230 V AC downward
18	= 24V DC 1 Watt downward
19	= 24V DC Earth faston downward

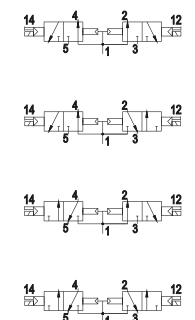

Weight 250 g

AIR DISTRIBUTION



Modular base

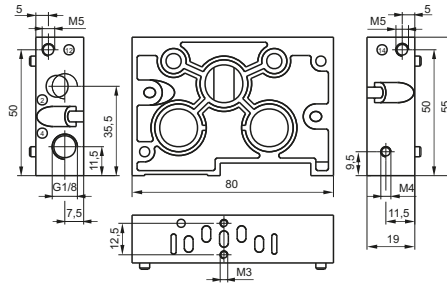

Coding: 2440.0

VERSION	
01	Modular base
06	Supply and exhaust closed
07	Supply closed
08	Exhaust closed

Inlet base

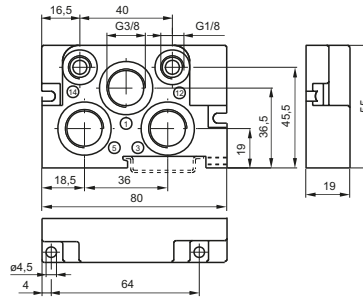

Coding: 2440.0

VERSION	
02	Right
03	Left

Weight 110 g

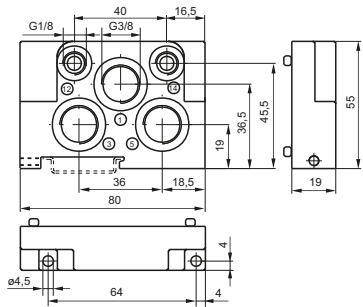

Weight 110 g

Intermediate air intake

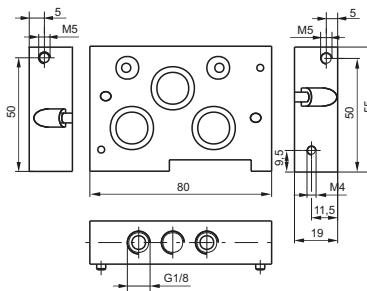

Coding: 2440.10

Weight 185 g

Closing plate

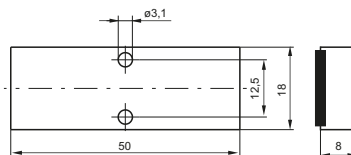

Coding: 2440.00

Weight 25 g

Diaphragm plug



Coding: 2440.17

The integral electrical design for the series 2400 valve is extremely flexible, allowing the production of pre-wired solenoid valve manifolds, the configuration of which can be determined at the point of assembly. The 24 VDC, 12 VDC (equivalent PNP) and 24 VAC\* modules are available with 2 or 4 positions. The system assembled is designed for an IP40 protection. IP65 is available on request.

\* Attention : If the working tension is 24 VAC DO NOT using modules with protection diode

1  
AIR DISTRIBUTION

Support plates are supplied to mount the electrical connection elements to the manifold modules. Individual valves can still be removed from the manifold even after assembly is complete. One support plate is required per element.

The elements connect together using an upper coupling and lower fixing screw.

It is possible to use the 2 position element as the first terminal on 2, 6, 10, 14 position assemblies..

Up to 16 valves can be operated by using 4x4 position elements.

On single solenoid assemblies electrical connection is made using an D-SUB 25 multi-connector.

On double solenoid assemblies electrical connection is made using an D-SUB 37 multi-connector.

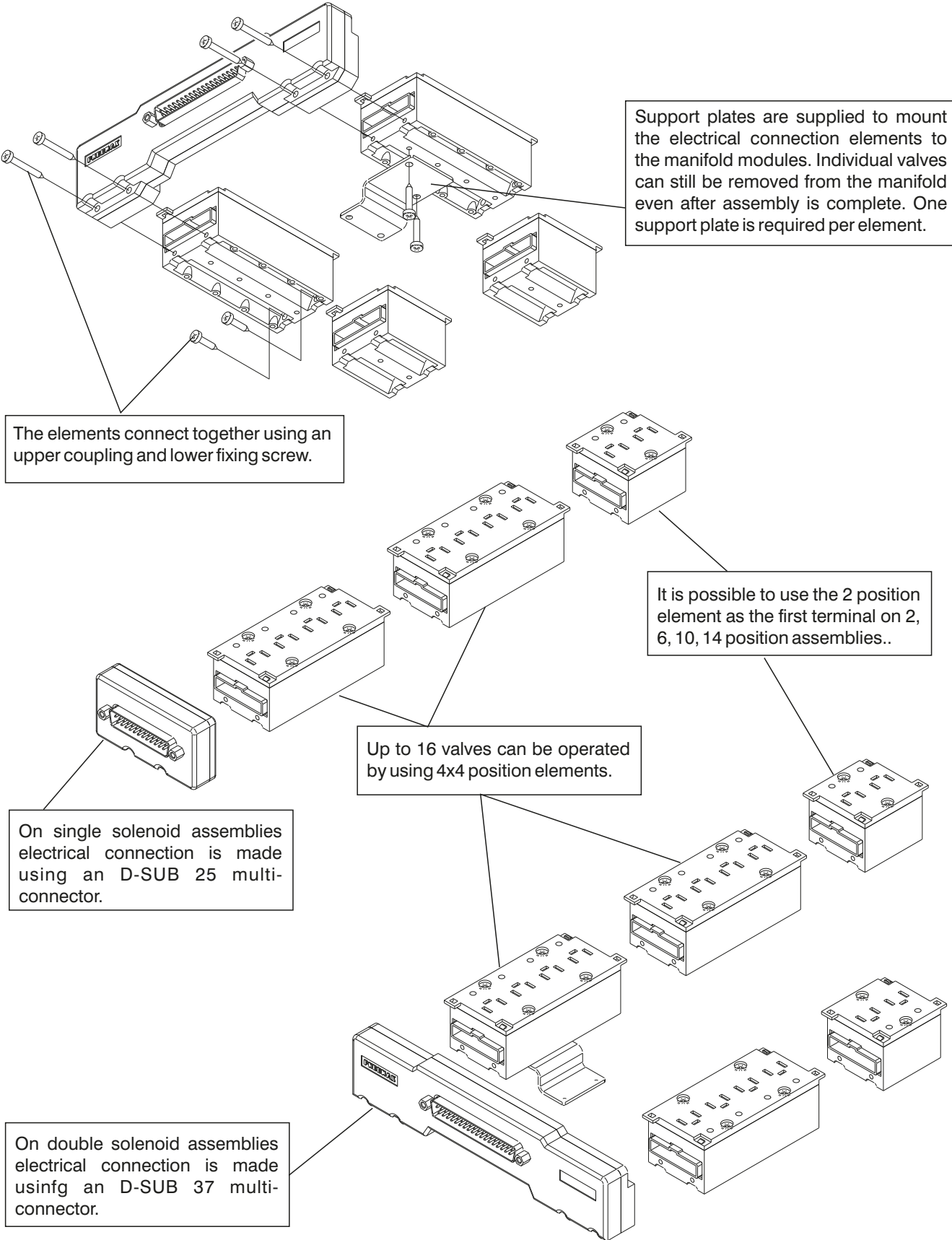

► **Module for connections**



Weight 30 g  
\* only for VDC

2400.02.T



Weight 50 g  
\* only for VDC

2400.04.T

Coding: 2400.P.T

	POSITIONS
P	04 = 4 positions
	02 = 2 positions
	TYPE
	00 = Left IP40-PNP
	02 = Left IP40-PNP with protection diode
	10 = Left IP65-PNP
	12 = Left IP65-PNP with protection diode
T	01 = Right IP40-PNP
	03 = Right IP40-PNP with protection diode
	11 = Right IP65-PNP
	13 = Right IP65-PNP with protection diode

► **Front connector IP65**



Weight 120 g  
The IP65 protection is obtained by IP65 Pneumax cable

2400.37.10



Weight 40 g  
The IP65 protection is obtained by IP65 Pneumax cable

2400.25.10

Coding: 2400.P.10

	POLES
P	37 = 37 poles
	25 = 25 poles

► **Plug**



Coding: 2400.00

Weight 5 g

► **Closing plate electrical positions**

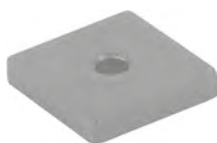

Coding: 2400.15.00

Weight 2 g

► **VDMA support plate**



Coding: 2440.50

Weight 20 g

► **FLAT support plate**



Coding: 2430.50

Weight 20 g

1  
AIR DISTRIBUTION



1  
AIR DISTRIBUTION

▶ 4 positions box with 25 contacts connector

Coding: 2400.04.25



Weight 65 g

▶ 15mm male connector with 2 metres cable

Coding: 2400.15.02



Weight 98 g

▶ In line cable complete with connector IP40

Coding: 2400.**T**.**L**.00



	CONNECTORS
<b>T</b>	25 = 25 poles
	37 = 37 poles
	CABLE LENGTH
<b>L</b>	03 = 3 meters
	05 = 5 meters
	10 = 10 meters

2400.**T**.**L**.00

▶ Cable complete with connector, 25 Poles IP65

Coding: 2300.25.**L**.**C**



	CABLE LENGTH
<b>L</b>	03 = 3 meters
	05 = 5 meters
	10 = 10 meters
	FUNCTION
<b>F</b>	31 = Closed centres
	32 = Open centres
	33 = Pressured centres

▶ Cable complete with connector, 37 Poles IP65

Coding: 2400.37.**L**.**C**



	CABLE LENGTH
<b>L</b>	03 = 3 meters
	05 = 5 meters
	10 = 10 meters
	FUNCTION
<b>F</b>	31 = Closed centres
	32 = Open centres
	33 = Pressured centres



**SUB-D 25 CONTACTS CONNECTOR**

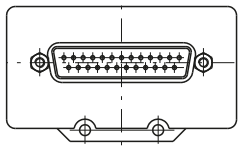
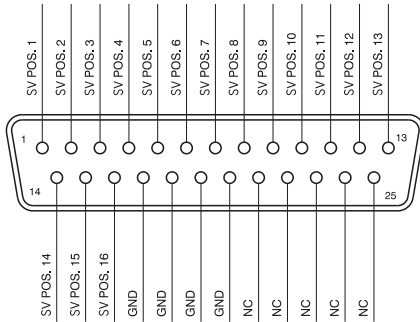

**SUB-D 37 CONTACTS CONNECTOR**

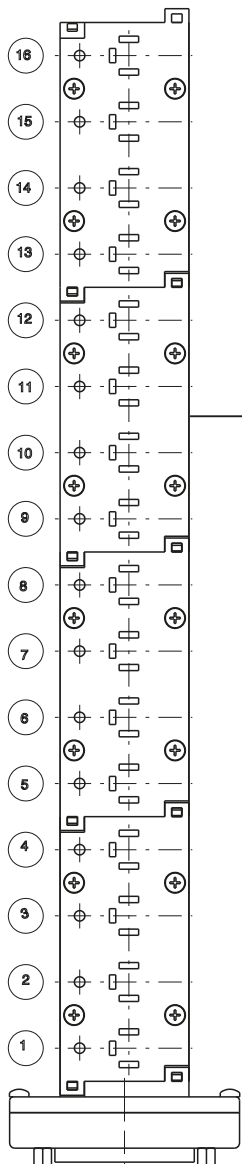
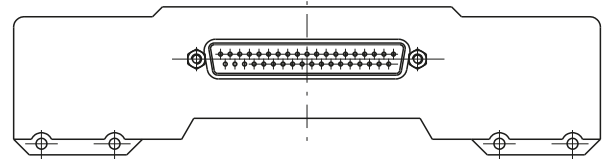
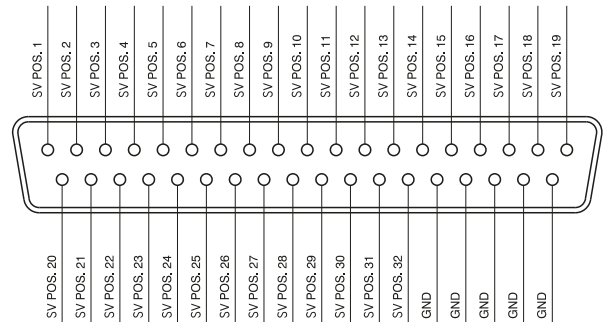

Left modules

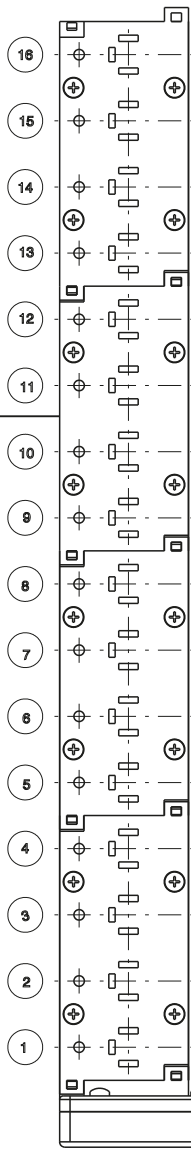

Right modules

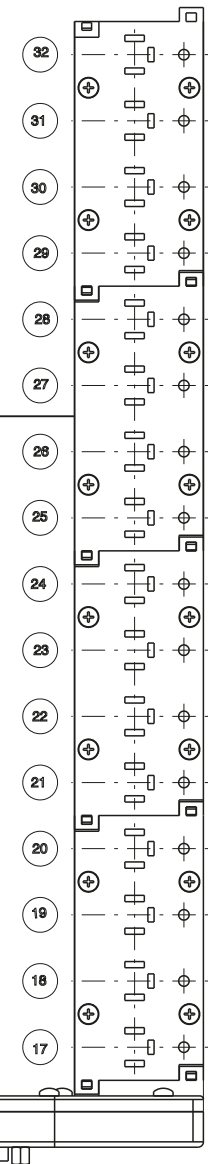

1  
AIR DISTRIBUTION



## Series 2600

### General

They have been designed to be easily assembled into groups or manifolds.  
The 2600 series comprises a range of products classified according to the body size of 26mm divided into 3 types "LINE", "FLAT" and "VDMA".  
Is not included the integral electrical connection

AIR DISTRIBUTION

### Construction characteristics

Central body	Extruded aluminium bar with chemical nickel treatment and PTFE (polytetrafluorethylene)
Connection plates	Die-cast aluminium
Operators	Technopolymer
Spool seals	Oil resistant nitrile rubber - HNBR
Spools	Aluminium 2011
Springs	AISI 302 stainless steel
Pistons	Technopolymer
Piston seals	Oil resistant nitrile rubber - NBR

### Ordering codes for miniature solenoid valves

The 15 mm. miniature solenoid valve with 1,1 mm. orifice has been selected for piloting this series of valves (see Series 300).  
This results in low response times and reduced power consumption.  
The valve can be supplied with the coil upward or downward (multipolar connections) depending on the application.  
Codes are as follows:

#### Coil upward code

- 01 = miniature solenoid 12 VDC
- 02 = miniature solenoid 24 VDC
- 05 = miniature solenoid 24 VAC
- 06 = miniature solenoid 110 VAC
- 07 = miniature sol. 230 VAC
- 08 = miniature sol. 24 VDC 1W
- 09 = miniature sol. 24 VDC Earth faston

#### Coil downward code

- 11 = miniature solenoid 12 VDC
- 12 = miniature solenoid 24 VDC
- 15 = miniature solenoid 24 VAC
- 16 = miniature solenoid 110 VAC
- 17 = miniature sol. 230 VAC
- 18 = miniature sol. 24 VDC 1W Downward
- 19 = miniature sol. 24 VDC Earth faston Downward

Miniature solenoid c  homologated are available (see Series 300).

### Use and maintenance

The average life of the solenoid valve exceeds 50.000.000 cycles when used under optimum conditions.  
Adequate lubrication reduces seals wear, just as proper filtering of supply air prevents the build-up of dirt that can cause malfunction.  
Ensure the valve is used within our recommended criteria for pressure and temperature.  
In dirty or dusty environments, the exhaust ports should be protected.  
A seal kit including the spool is available for overhauling the valve. This operation does not require a skilled worker, although a particular care should be taken when reassembling the valve.

**Pneumatic - Spring**

Coding: 261 **A**.52.00.19

Operational characteristics	
Fluid	Filtered air. No lubrication needed, if applied it shall be continuous
Max working pressure (bar)	10
Temperature °C	-5 ÷ +50
Flow rate at 6 bar with Δp=1 (NI/min)	1500
Orifice size (mm)	9
Pilot ports size	G1/8"

WORKING PORTS SIZE	
<b>A</b>	1 = G3/8"
	5 = G1/4"
	8 = Quick fitting tube Ø10

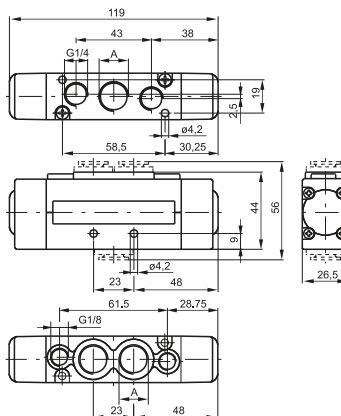

Weight 235 g  
Minimum piloting pressure 2 bar

For dimension "A" see ordering code

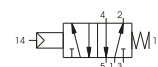

1  
AIR DISTRIBUTION

**Pneumatic - Differential**

Coding: 261 **A**.52.00.16

Operational characteristics	
Fluid	Filtered air. No lubrication needed, if applied it shall be continuous
Max working pressure (bar)	10
Temperature °C	-5 ÷ +50
Flow rate at 6 bar with Δp=1 (NI/min)	1500
Orifice size (mm)	9
Pilot ports size	G1/8"

WORKING PORTS SIZE	
<b>A</b>	1 = G3/8"
	5 = G1/4"
	8 = Quick fitting tube Ø10

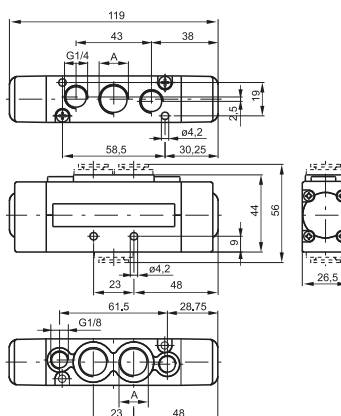

Weight 235 g  
Minimum piloting pressure 2 bar

For dimension "A" see ordering code

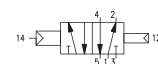



1  
AIR DISTRIBUTION

**Pneumatic - Differential (External)**

Coding: 261(A).52.00.17

Operational characteristics	
Fluid	Filtered air. No lubrication needed, if applied it shall be continuous
Max working pressure (bar)	10
Temperature °C	-5 ÷ +50
Flow rate at 6 bar with Δp=1 (NI/min)	1500
Orifice size (mm)	9
Pilot ports size	G1/8"

WORKING PORTS SIZE	
<b>1</b>	= G3/8"
<b>5</b>	= G1/4"
<b>8</b>	= Quick fitting tube Ø10

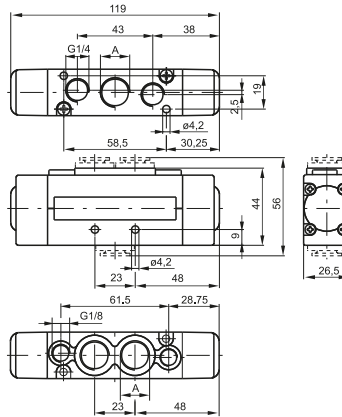

Weight 235 g  
Minimum piloting pressure 2 bar

For dimension "A" see ordering code

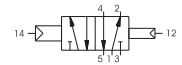

**Pneumatic - Pneumatic**

Coding: 261(A).52.00.18

Operational characteristics	
Fluid	Filtered air. No lubrication needed, if applied it shall be continuous
Max working pressure (bar)	10
Temperature °C	-5 ÷ +50
Flow rate at 6 bar with Δp=1 (NI/min)	1500
Orifice size (mm)	9
Pilot ports size	G1/8"

WORKING PORTS SIZE	
<b>1</b>	= G3/8"
<b>5</b>	= G1/4"
<b>8</b>	= Quick fitting tube Ø10

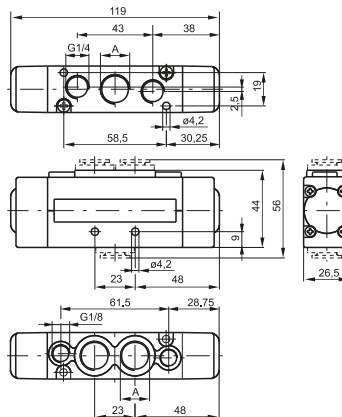

Weight 235 g  
Minimum piloting pressure 1,5 bar

For dimension "A" see ordering code





**Solenoid-Spring/Differential**

Coding: 261 **A**.52.00. **V**. **T**

Operational characteristics	
Fluid	Filtered air. No lubrication needed, if applied it shall be continuous
Max working pressure (bar)	10
Temperature °C	-5 ÷ +50
Flow rate at 6 bar with Δp=1 (NI/min)	1500
Orifice size (mm)	9

WORKING PORTS SIZE	
<b>A</b>	1 = G3/8"
	5 = G1/4"
	8 = Quick fitting tube Ø10
VERSION	
	39 = Solenoid - Spring
	29 = Solenoid external-Spring
	36 = Solenoid-Differential
<b>V</b>	37 = Solenoid-Differential external
	26 = Solenoid external-Differential
	27 = Solenoid external-Differential external
VOLTAGE	
	01 = 12V DC
	02 = 24V DC
	05 = 24V AC
	06 = 110V AC
	07 = 230 V AC
	08 = 24V DC 1W
<b>T</b>	09 = 24V DC downward
	11 = 12V DC downward
	12 = 24V DC downward
	15 = 24V AC downward
	16 = 110V AC downward
	17 = 230 V AC downward
	18 = 24V DC 1W downward
	19 = 24V DC Earth faston downward

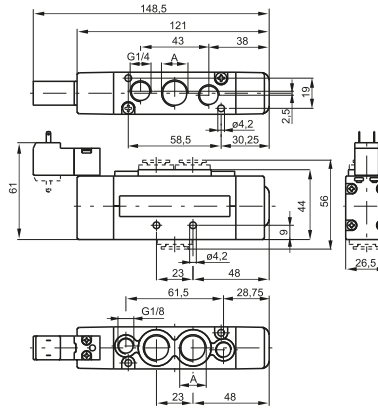

For dimension "A" see ordering code

Weight 275 g  
Minimum piloting pressure 2 bar

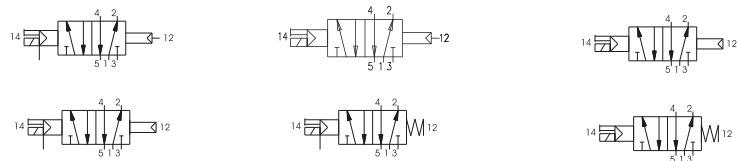

1  
AIR DISTRIBUTION

**Solenoid - Solenoid**

Coding: 261 **A**.52.00. **V**. **T**

Operational characteristics	
Fluid	Filtered air. No lubrication needed, if applied it shall be continuous
Max working pressure (bar)	10
Temperature °C	-5 ÷ +50
Flow rate at 6 bar with Δp=1 (NI/min)	1500
Orifice size (mm)	9

WORKING PORTS SIZE	
<b>A</b>	1 = G3/8"
	5 = G1/4"
	8 = Quick fitting tube Ø10
VERSION	
	35 = Solenoid-Solenoid
<b>V</b>	24 = Solenoid external-Solenoid external
VOLTAGE	
	01 = 12V DC
	02 = 24V DC
	05 = 24V AC
	06 = 110V AC
	07 = 230 V AC
	08 = 24V DC 1W
<b>T</b>	09 = 24V DC downward
	11 = 12V DC downward
	12 = 24V DC downward
	15 = 24V AC downward
	16 = 110V AC downward
	17 = 230 V AC downward
	18 = 24V DC 1W downward
	19 = 24V DC Earth faston downward

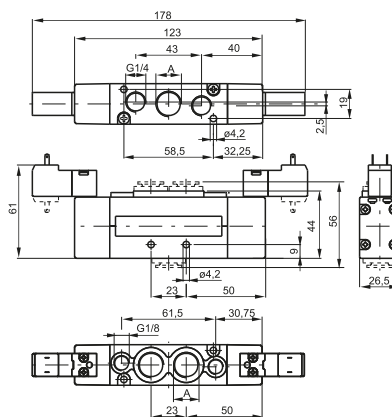

For dimension "A" see ordering code

Weight 295 g  
Minimum piloting pressure 1,5 bar

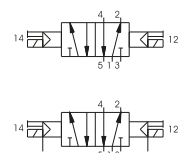



**Pneumatic - Pneumatic 5 ways 3 connections**

Coding: 261(A).53(F).18

Operational characteristics	
Fluid	Filtered air. No lubrication needed, if applied it shall be continuous
Max working pressure (bar)	10
Temperature °C	-5 ÷ +50
Flow rate at 6 bar with $\Delta p=1$ (NI/min)	1350
Orifice size (mm)	9
Pilot ports size	M5

A	WORKING PORTS SIZE
	1 = G3/8"
	5 = G1/4"
F	FUNCTION
	31 = Closed centres
	32 = Open centres
	33 = Pressured centres

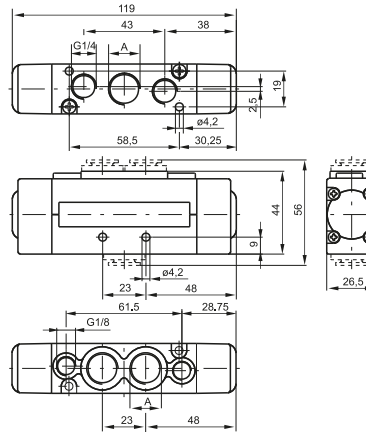

For dimension "A" see ordering code

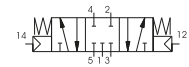
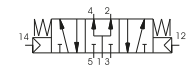

Weight 245 g  
Minimum piloting pressure 3 bar

**Solenoid - Solenoid 5 ways 3 connections**

Coding: 261(A).53(F.V.T)

Operational characteristics	
Fluid	Filtered air. No lubrication needed, if applied it shall be continuous
Max working pressure (bar)	10
Temperature °C	-5 ÷ +50
Flow rate at 6 bar with $\Delta p=1$ (NI/min)	1350
Orifice size (mm)	9

A	WORKING PORTS SIZE
	1 = G3/8"
	5 = G1/4"
F	FUNCTION
	31 = Closed centres
	32 = Open centres
	33 = Pressured centres
V	VERSION
	24 = Solenoid external-Solenoid external
	35 = Solenoid-Solenoid
T	VOLTAGE
	01 = 12V DC
	02 = 24V DC
	05 = 24V AC
	06 = 110V AC
	07 = 230 V AC
	08 = 24V DC 1W
	09 = 24V DC downward
	11 = 12V DC downward
	12 = 24V DC downward
	15 = 24V AC downward
	16 = 110V AC downward
17 = 230 V AC downward	
18 = 24V DC 1W downward	
19 = 24V DC Earth faston downward	

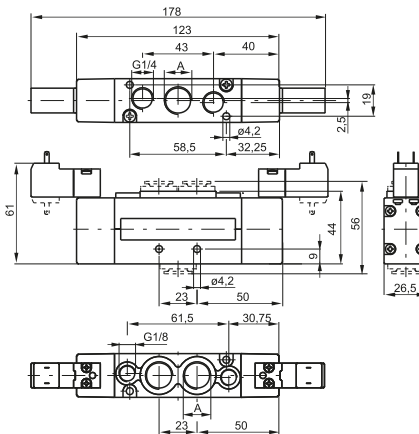

For dimension "A" see ordering code

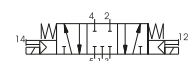
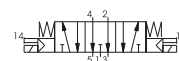
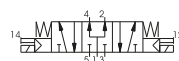

Weight 245 g  
Minimum piloting pressure 3 bar

**Pneumatic - Spring**

Coding: 263 **A**.52.00.19

Operational characteristics	
Fluid	Filtered air. No lubrication needed, if applied it shall be continuous
Max working pressure (bar)	10
Temperature °C	-5 ÷ +50
Flow rate at 6 bar with $\Delta p=1$ (NI/min)	1500
Orifice size (mm)	9
Pilot ports size	M5

WORKING PORTS SIZE	
<b>A</b>	1 = G3/8"
	5 = G1/4"
	8 = Quick fitting tube $\varnothing 10$



Weight 185 g  
Minimum piloting pressure 2 bar

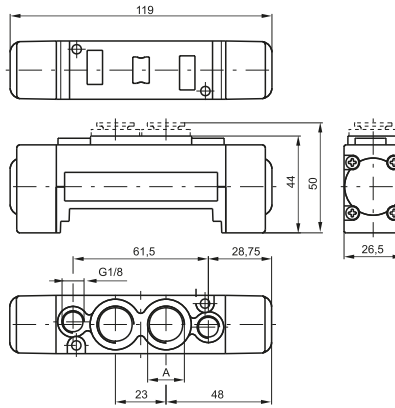

For dimension "A" see ordering code

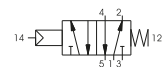

**Pneumatic - Differential**

Coding: 263 **A**.52.00.16

Operational characteristics	
Fluid	Filtered air. No lubrication needed, if applied it shall be continuous
Max working pressure (bar)	10
Temperature °C	-5 ÷ +50
Flow rate at 6 bar with $\Delta p=1$ (NI/min)	1500
Orifice size (mm)	9
Pilot ports size	M5

WORKING PORTS SIZE	
<b>A</b>	1 = G3/8"
	5 = G1/4"
	8 = Quick fitting tube $\varnothing 10$



Weight 185 g  
Minimum piloting pressure 2 bar

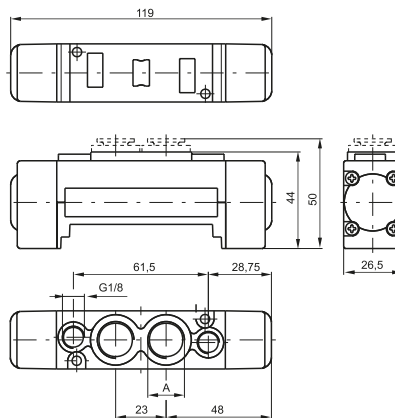

For dimension "A" see ordering code

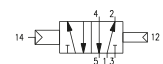

**Pneumatic - Differential (External)**

Coding: 263 **A**.52.00.17

Operational characteristics	
Fluid	Filtered air. No lubrication needed, if applied it shall be continuous
Max working pressure (bar)	10
Temperature °C	-5 ÷ +50
Flow rate at 6 bar with $\Delta p=1$ (NI/min)	1500
Orifice size (mm)	9
Pilot ports size	M5

WORKING PORTS SIZE	
<b>A</b>	1 = G3/8"
	5 = G1/4"
	8 = Quick fitting tube $\varnothing 10$



Weight 185 g  
Minimum piloting pressure 2 bar

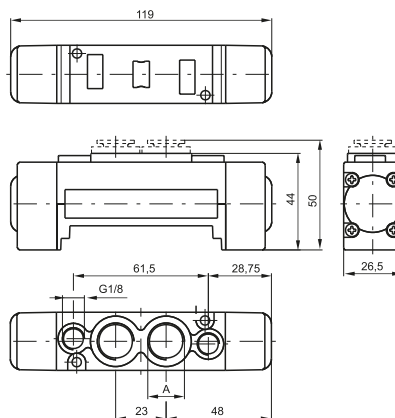

For dimension "A" see ordering code

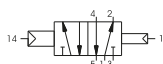

1  
AIR DISTRIBUTION



**Spool valves and solenoid valves**  
**Series 2600 - Size 26mm FLAT**

**Pneumatic - Pneumatic**

**Coding: 263A.52.00.18**

**Operational characteristics**

Fluid	Filtered air. No lubrication needed, if applied it shall be continuous
Max working pressure (bar)	10
Temperature °C	-5 ÷ +50
Flow rate at 6 bar with Δp=1 (Nl/min)	1500
Orifice size (mm)	9
Pilot ports size	M5

<b>WORKING PORTS SIZE</b>	
<b>1</b>	= G3/8"
<b>5</b>	= G1/4"
<b>8</b>	= Quick fitting tube Ø10

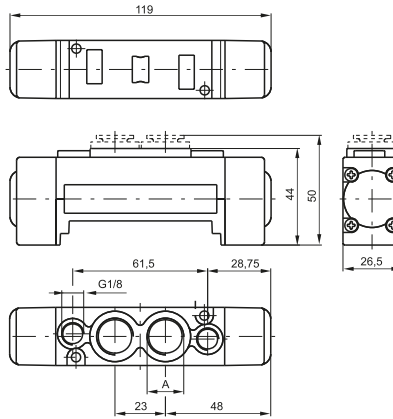

For dimension "A" see ordering code

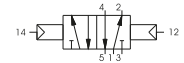

Weight 185 g  
 Minimum piloting pressure 1,5 bar

**1**  
**AIR DISTRIBUTION**

**Solenoid-Spring / Differential**

Coding: 263A.52.00.V.T

Operational characteristics	
Fluid	Filtered air. No lubrication needed, if applied it shall be continuous
Max working pressure (bar)	10
Temperature °C	-5 ÷ +50
Flow rate at 6 bar with Δp=1 (NI/min)	1500
Orifice size (mm)	9

WORKING PORTS SIZE	
<b>A</b>	1 = G3/8"
	5 = G1/4"
	8 = Quick fitting tube Ø10
VERSION	
	39 = Solenoid - Spring
	29 = Solenoid external-Spring
	36 = Solenoid-Differential
<b>V</b>	37 = Solenoid-Differential external
	26 = Solenoid external-Differential
	27 = Solenoid external-Differential external
VOLTAGE	
	01 = 12V DC
	02 = 24V DC
	05 = 24V AC
	06 = 110V AC
	07 = 230 V AC
	08 = 24V DC 1W
<b>T</b>	09 = 24V DC downward
	11 = 12V DC downward
	12 = 24V DC downward
	15 = 24V AC downward
	16 = 110V AC downward
	17 = 230 V AC downward
	18 = 24V DC 1W downward
	19 = 24V DC Earth faston downward

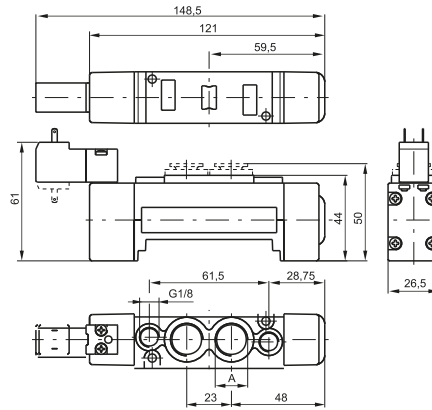

For dimension "A" see ordering code

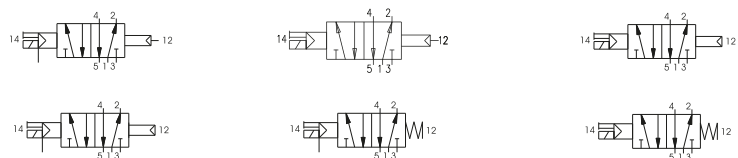

Weight 220 g  
Minimum piloting pressure 2 bar

1  
AIR DISTRIBUTION

**Solenoid - Solenoid**

Coding: 263A.52.00.V.T

Operational characteristics	
Fluid	Filtered air. No lubrication needed, if applied it shall be continuous
Max working pressure (bar)	10
Temperature °C	-5 ÷ +50
Flow rate at 6 bar with Δp=1 (NI/min)	1500
Orifice size (mm)	9

WORKING PORTS SIZE	
<b>A</b>	1 = G3/8"
	5 = G1/4"
	8 = Quick fitting tube Ø10
VERSION	
<b>V</b>	35 = Solenoid-Solenoid
	24 = Solenoid external-Solenoid external
VOLTAGE	
	01 = 12V DC
	02 = 24V DC
	05 = 24V AC
	06 = 110V AC
	07 = 230 V AC
	08 = 24V DC 1W
<b>T</b>	09 = 24V DC downward
	11 = 12V DC downward
	12 = 24V DC downward
	15 = 24V AC downward
	16 = 110V AC downward
	17 = 230 V AC downward
	18 = 24V DC 1W downward
	19 = 24V DC Earth faston downward

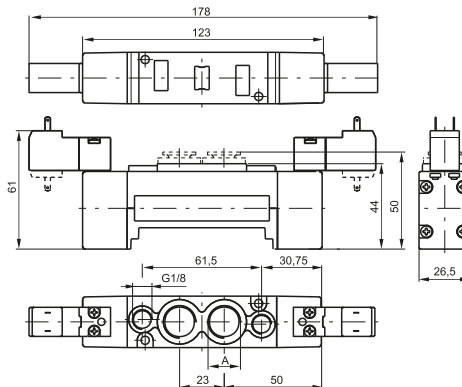

For dimension "A" see ordering code

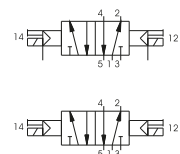

Weight 250 g  
Minimum piloting pressure 1,5 bar



# Spool valves and solenoid valves Series 2600 - Size 26mm FLAT

1 AIR DISTRIBUTION

## Pneumatic - Pneumatic 5 ways 3 connections

Coding: 263A.53.F.18

Operational characteristics	
Fluid	Filtered air. No lubrication needed, if applied it shall be continuous
Max working pressure (bar)	10
Temperature °C	-5 ÷ +50
Flow rate at 6 bar with Δp=1 (NI/min)	1350
Orifice size (mm)	9
Pilot ports size	M5

A	WORKING PORTS SIZE
	1 = G3/8"
	5 = G1/4"
F	FUNCTION
	31 = Closed centres
	32 = Open centres
	33 = Pressured centres

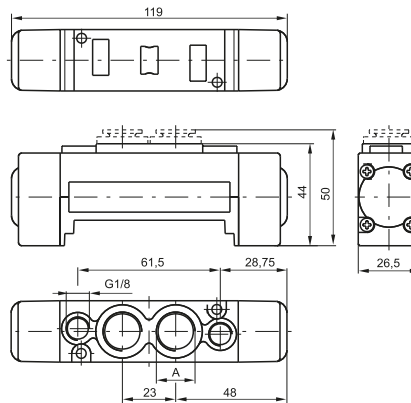

For dimension "A" see ordering code

Weight 195 g  
Minimum piloting pressure 3 bar

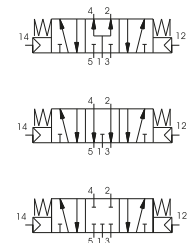

## Solenoid - Solenoid 5 ways 3 connections

Coding: 263A.53.F.V.T

Operational characteristics	
Fluid	Filtered air. No lubrication needed, if applied it shall be continuous
Max working pressure (bar)	10
Temperature °C	-5 ÷ +50
Flow rate at 6 bar with Δp=1 (NI/min)	1350
Orifice size (mm)	9

A	WORKING PORTS SIZE
	1 = G3/8"
	5 = G1/4"
F	FUNCTION
	31 = Closed centres
	32 = Open centres
	33 = Pressured centres
V	VERSION
	24 = Solenoid external-Solenoid external
	35 = Solenoid-Solenoid
T	VOLTAGE
	01 = 12V DC
	02 = 24V DC
	05 = 24V AC
	06 = 110V AC
	07 = 230 V AC
	08 = 24V DC 1W
	09 = 24V DC downward
	11 = 12V DC downward
	12 = 24V DC downward
	15 = 24V AC downward
16 = 110V AC downward	
17 = 230 V AC downward	
18 = 24V DC 1W downward	
19 = 24V DC Earth faston downward	

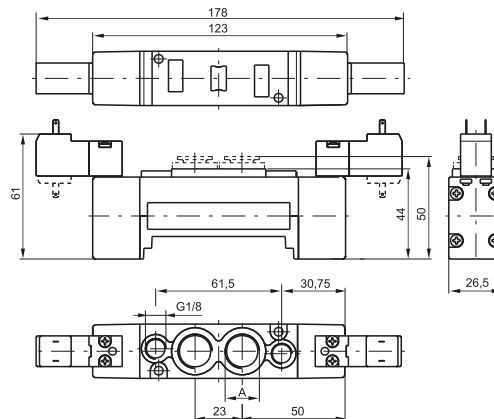

For dimension "A" see ordering code

Weight 270 g  
Minimum piloting pressure 3 bar

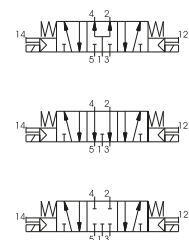

▶ **Modular base**

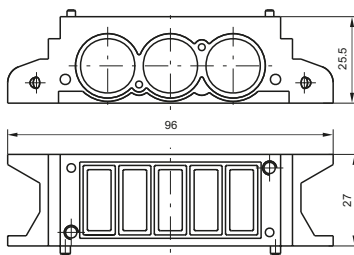

Coding: 2630.01

Weight 80 g

▶ **Inlet base**

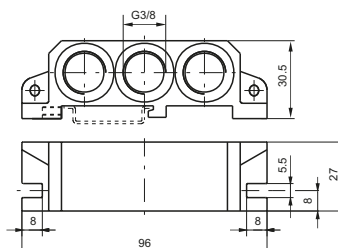

Coding: 2630.02

Weight 80 g

2630.02

VERSION	
02	Right
03	Left

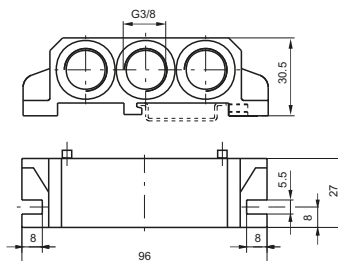

Weight 100 g

2630.03

▶ **Intermediate air intake**

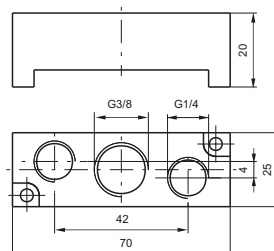

Coding: 2630.10

Weight 60 g  
to be assembled instead of a valve

▶ **Closing plate**

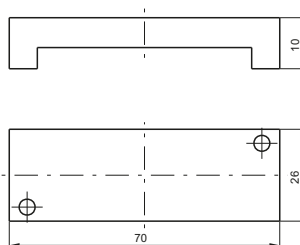

Coding: 2630.00

Weight 20 g

▶ **Diaphragm plug**



Coding: 2630.17

Weight 5 g



1  
AIR DISTRIBUTION

**Pneumatic - Spring**

Coding: 2645.52.00.19

**Operational characteristics**

Fluid	Filtered air. No lubrication needed, if applied it shall be continuous
Max working pressure (bar)	10
Temperature °C	-5 ÷ +50
Flow rate at 6 bar with Δp=1 (NI/min)	1100
Orifice size (mm)	7.5

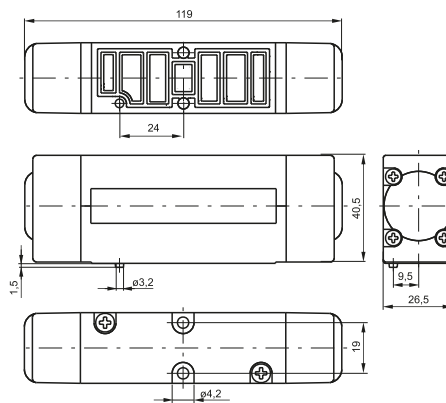

Weight 235 g  
Minimum piloting pressure 2 bar



**Pneumatic - Differential**

Coding: 2645.52.00.16

**Operational characteristics**

Fluid	Filtered air. No lubrication needed, if applied it shall be continuous
Max working pressure (bar)	10
Temperature °C	-5 ÷ +50
Flow rate at 6 bar with Δp=1 (NI/min)	1100
Orifice size (mm)	7.5

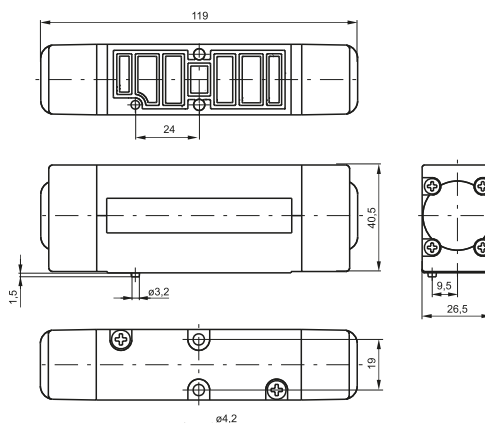

Weight 235 g  
Minimum piloting pressure 2 bar



**Pneumatic - Differential (External)**

Coding: 2645.52.00.17

**Operational characteristics**

Fluid	Filtered air. No lubrication needed, if applied it shall be continuous
Max working pressure (bar)	10
Temperature °C	-5 ÷ +50
Flow rate at 6 bar with Δp=1 (NI/min)	1100
Orifice size (mm)	7.5

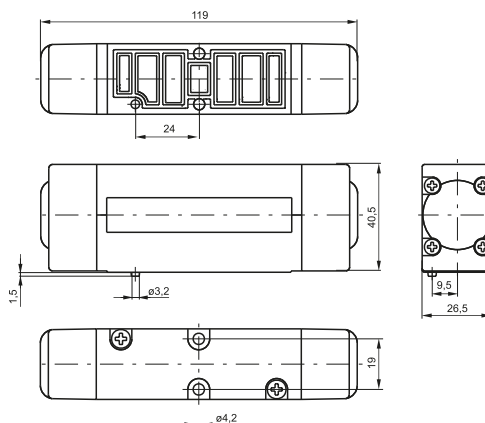

Weight 235 g  
Minimum piloting pressure 2 bar

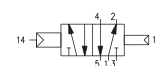



**Pneumatic - Pneumatic**

Coding: 2645.52.00.18

Operational characteristics	
Fluid	Filtered air. No lubrication needed, if applied it shall be continuous
Max working pressure (bar)	10
Temperature °C	-5 ± +50
Flow rate at 6 bar with $\Delta p=1$ (l/min)	1100
Orifice size (mm)	7.5



Weight 255 g  
Minimum piloting pressure 1,5 bar

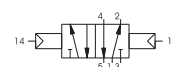
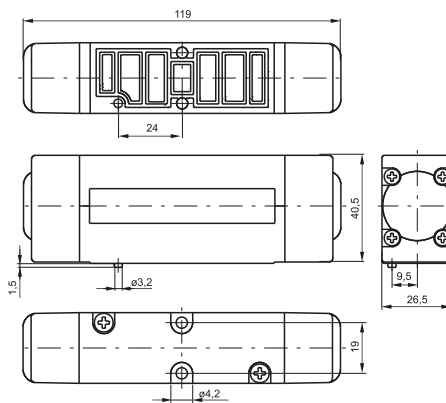

1  
AIR DISTRIBUTION



AIR DISTRIBUTION

**Solenoid-Spring / Differential**

Coding: 264<sup>C</sup>.52.00.<sup>V</sup>.<sup>T</sup>

Operational characteristics	
Fluid	Filtered air. No lubrication needed, if applied it shall be continuous
Max working pressure (bar)	10
Temperature °C	-5 ÷ +50
Flow rate at 6 bar with Δp=1 (NI/min)	1100
Orifice size (mm)	7.5

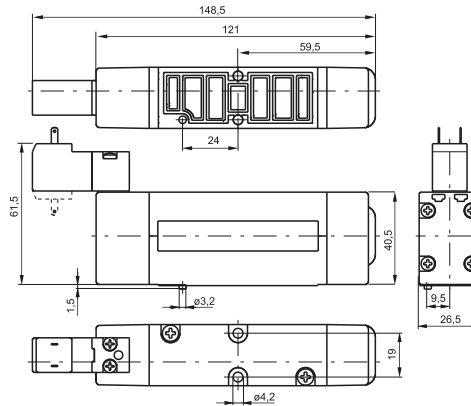

<b>C</b>	TYPE ELECTROPILOT EXHAUST
	1 = on base (only for self feeding valves) 5 = on pilot (for all version)
<b>V</b>	VERSION
	39 = Solenoid - Spring
	29 = Solenoid external-Spring
	36 = Solenoid-Differential
	37 = Solenoid-Differential external
<b>T</b>	VOLTAGE
	01 = 12V DC
	02 = 24V DC
	05 = 24V AC
	06 = 110V AC
	07 = 230 V AC
	08 = 24V DC 1W
	09 = 24V DC downward
	11 = 12V DC downward
12 = 24V DC downward	
15 = 24V AC downward	
16 = 110V AC downward	
17 = 230 V AC downward	
18 = 24V DC 1W downward	
19 = 24V DC Earth faston downward	

Weight 270 g  
Minimum piloting pressure 2 bar

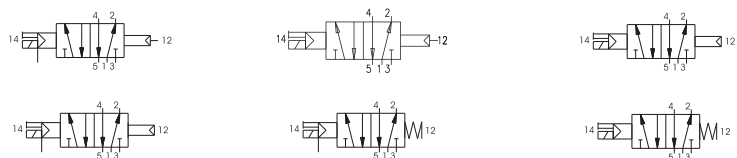

**Solenoid - Solenoid**

Coding: 264<sup>C</sup>.52.00.<sup>V</sup>.<sup>T</sup>

Operational characteristics	
Fluid	Filtered air. No lubrication needed, if applied it shall be continuous
Max working pressure (bar)	10
Temperature °C	-5 ÷ +50
Flow rate at 6 bar with Δp=1 (NI/min)	1100
Orifice size (mm)	7.5

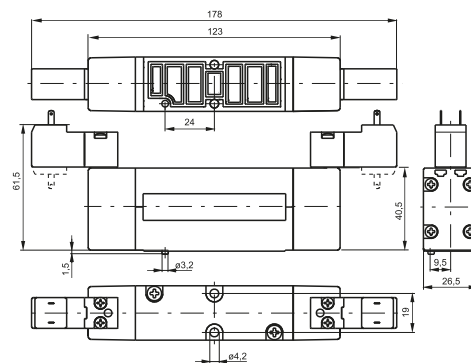

<b>C</b>	TYPE ELECTROPILOT EXHAUST
	1 = on base (only for self feeding valves) 5 = on pilot (for all version)
<b>V</b>	VERSION
	24 = Solenoid external-Solenoid external
	35 = Solenoid-Solenoid
<b>T</b>	VOLTAGE
	01 = 12V DC
	02 = 24V DC
	05 = 24V AC
	06 = 110V AC
	07 = 230 V AC
	08 = 24V DC 1W
	09 = 24V DC downward
	11 = 12V DC downward
	12 = 24V DC downward
	15 = 24V AC downward
	16 = 110V AC downward
	17 = 230 V AC downward
	18 = 24V DC 1W downward
	19 = 24V DC Earth faston downward

Weight 305 g  
Minimum piloting pressure 1,5 bar

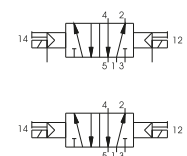

**Pneumatic - Pneumatic 5 ways 3 connections**

Coding: 264 **C**.53.**F**.18

Operational characteristics	
Fluid	Filtered air. No lubrication needed, if applied it shall be continuous
Max working pressure (bar)	10
Temperature °C	-5 ÷ +50
Flow rate at 6 bar with Δp=1 (NI/min)	1000
Orifice size (mm)	7.5

<b>C</b>	TYPE ELECTROPILOT EXHAUST 1 = on base (only for self feeding valves) 5 = on pilot (for all version)
<b>F</b>	FUNCTION 31 = Closed centres 32 = Open centres 33 = Pressured centres

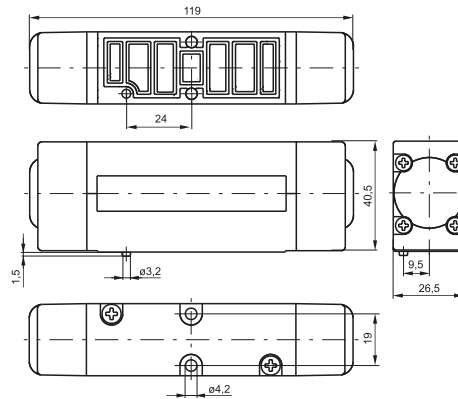

Weight 245 g  
Minimum piloting pressure 3 bar

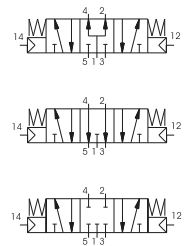

**Solenoid - Solenoid 5 ways 3 connections**

Coding: 264 **C**.53.**F**.**V**.**T**

Operational characteristics	
Fluid	Filtered air. No lubrication needed, if applied it shall be continuous
Max working pressure (bar)	10
Temperature °C	-5 ÷ +50
Flow rate at 6 bar with Δp=1 (NI/min)	1000
Orifice size (mm)	5

<b>C</b>	TYPE ELECTROPILOT EXHAUST 1 = on base (only for self feeding valves) 5 = on pilot (for all version)
<b>F</b>	FUNCTION 31 = Closed centres 32 = Open centres 33 = Pressured centres
<b>V</b>	VERSION 24 = Solenoid external-Solenoid external 35 = Solenoid-Solenoid
<b>T</b>	VOLTAGE 01 = 12V DC 02 = 24V DC 05 = 24V AC 06 = 110V AC 07 = 230 V AC 08 = 24V DC 1W 09 = 24V DC downward 11 = 12V DC downward 12 = 24V DC downward 15 = 24V AC downward 16 = 110V AC downward 17 = 230 V AC downward 18 = 24V DC 1W downward 19 = 24V DC Earth faston downward

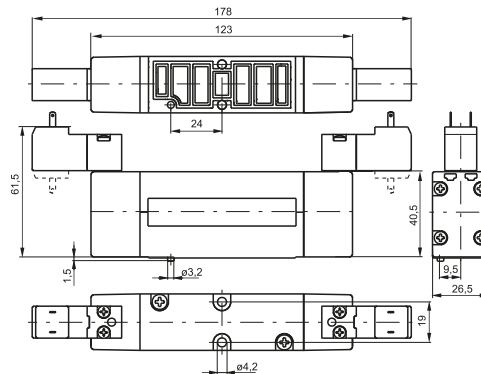

Weight 315 g  
Minimum piloting pressure 3 bar

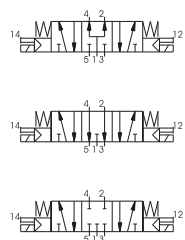

1  
AIR DISTRIBUTION

1

AIR DISTRIBUTION

Modular base

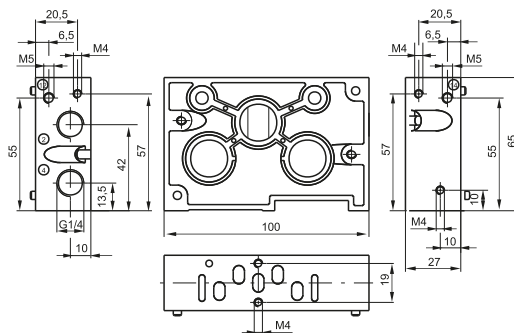

Coding: 2640.▼

VERSION
▼ 01 = Standard base
11 = Base for single separate inlet

Weight 220 g

Inlet base

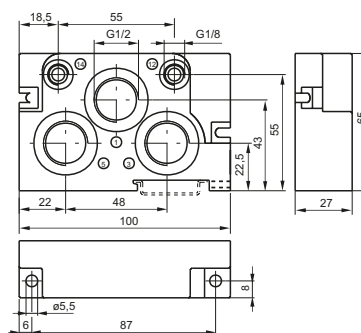

Coding: 2640.▼

VERSION
▼ 02 = Right
03 = Left

Weight 200 g

2640.02

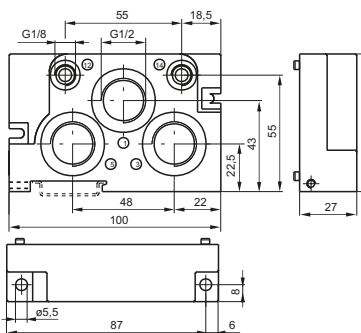

Weight 200 g

2640.03

Intermediate air intake

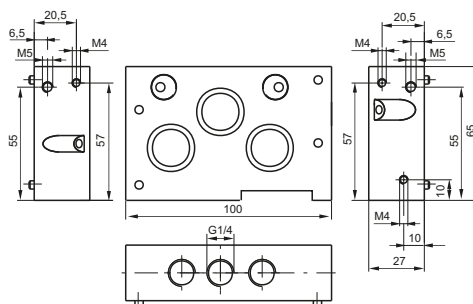

Coding: 2640.10

Closing plate

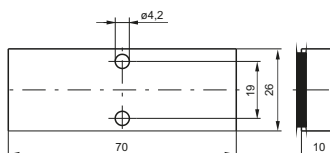

Coding: 2640.00

Weight 50 g



▶ Diaphragm plug

Coding: 2640.17



Weight 10 g



## Series 300

### General

The direct operated solenoid valve is the interface between pneumatic and electronic. In fact, it is actuated by an electrical signal and in turn gives a pneumatic signal directly available for small users or for actuating bigger pneumatic distributors.

A wide range of valves are needed for satisfying various applications. For this need we have available miniature components with very low volume and electrical impute as well as solenoid valves with large flow rate and power for heavy duty operations. These solenoid valves are usually 3/2, normally closed or normally open, but there are available the 2/2, closed or open, for vacuum and others.

Note that the direct operated valves can only be used with bases, individual or multiple with M5 or G 1/8" thread or with connections.

Some PNEUMAX solenoid valves are  homologated valid for USA and Canada (file n. VAIU2.E206325, VAIU8.E206325). For more details, refer to the coding, in the following pages.

The 10mm and 15mm solenoid valves are certified by UL in compliance with both Canadian and USA safety requirements as recognized component and included in the **UL file E206325** and bear the "UL Recognized Component" marking.

The 10mm and 15mm solenoid valves, since they are devices for "class 2 circuits", according with UL standard UL 429/CSA C22.2 N°139, are not considered dangerous for electric shock or fire and thus a **UL certification is not required for cables and connectors.**

Some solenoid valves, since they are devices for "class 2 circuits", according with UL standard UL 429/CSA C22.2 N°139, are not considered dangerous for electric shock or fire and thus a **UL certification is not required for cables and connectors.**

### Use and maintenance

Maintenance is normally not required for these components therefore the spare parts list is not provided.

Their construction complexity and low cost do not make repair economically viable. It's easier and more economic to replace the complete valve in case of malfunction.

For proper lubrication use only hydraulic oil class H such as Castrol type MAGNA GC 32.





This series of directly operated valves is characterized by its reduced dimensions. The high operating speed and high flow rate in consideration of the reduced dimensions, in combination with the high compatibility of the material used to manufacture them ensure a high variety of possible application fields.

All valves have manual override as standard and are available in 3/2 configuration N.O. and N.C. as well as 2/2 N.C. both 12 or 24 V DC or AC. Electrical connection can be via co moulded cables or via connector, in this configuration a LED indicates the coil status. Ensure that the fixing screws are tightened with 0.15 Nm maximum.

The 10mm Speed-up version are built in accordance to the ISO 15218-2003 standard with a flow rate of 24NI/min.

The coil integrates a dedicated circuit board which enables to contain the power consumption to 0.35 W in case of the high flow rate version and to 0.1W in case of the standard flow rate version.

AIR DISTRIBUTION

**Functional schematics for standard version**

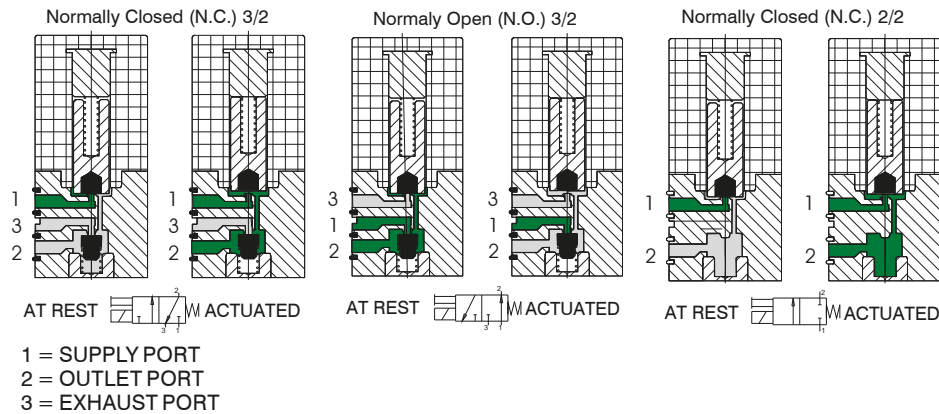

**Functional schematics for Speed-up version**

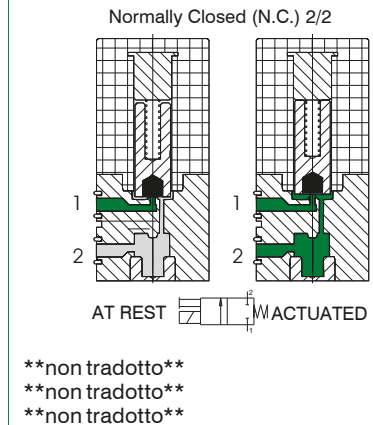

**Construction characteristics**

**Electrical part**

Miniature solenoid consisting of a coil made of copper wire of different diameters depending on voltage, isolated according to "F" class standard, with injection-moulded nylon-glass application. All parts forming the cladding, the electrical connections and the pole pieces are protected against corrosion.

**Mechanical part**

Stainless steel 430F armatures FPM poppets body in thermoplastic material and manual override and plug in nickel plated brass. Valves must be mounted on single or multiple manifold to be used.

**Technical characteristics**

	Pneumatic Standard Version	Speed-Up Version
Working pressure (bar)		0 ... 7
Orifice size (mm)	0,7	1.1
Temperature °C		-5° ... +50
Flow rate at 6 bar with Δp=1 (NI/min)	14	24
Exhaust flow rate (NI/min)	22	29
Life expectancy, number of cycles per minute (millions)		50
Compressed air, purity class according to ISO 8573-1:2010		5:4:4

	Electric Standard Version	Speed-Up Version
Voltages		12 ... 24 VDC
Power (Watt)	1,3	0,35 (1)
Voltage tolerance		-5% ... +10%
Response time according to ISO 12238, activation time (ms)		8
Response time according to ISO 12238, deactivation time (ms)		10
Copper wire isolation class		F (155°C)
Protection degree	IP65 (with cables), IP40 (with connectors), IP00 (with Faston)	

"Shifting time of pneumatic directional control valves or moving parts, logic devices were measured in accordance to ISO 12238:2001"

(1) = consumption wrapping in opening phase 3, 5W (10 ms), consumption wrapping in maintenance phase 0.35 W.



10 mm Standard miniature solenoid ordering codes

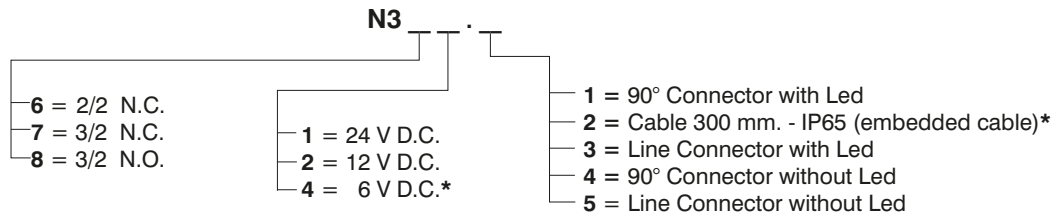

\* = The CE Directive does not apply to these versions

Miniature solenoid valve with cable

Weight 12 gr.

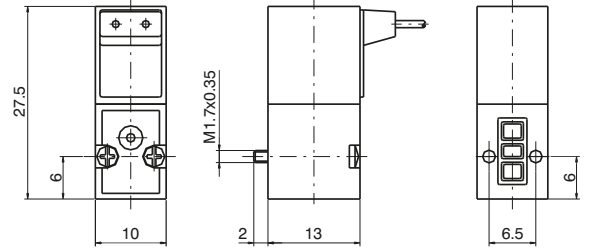

Miniature solenoid valve with 90° connector

Weight 12 gr.

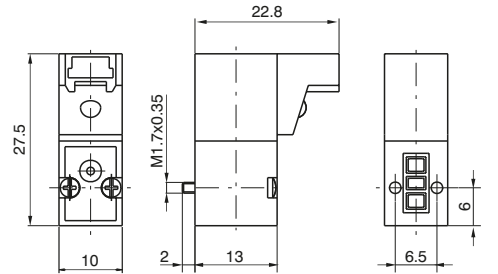

Miniature solenoid valve with line connector

Weight 12 gr.

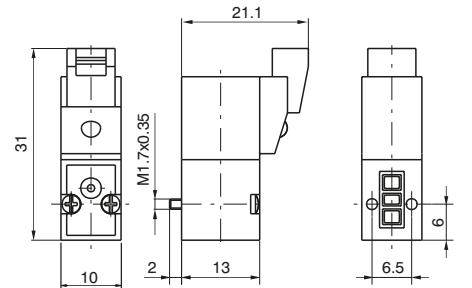

Connector

Ordering codes

- 371 .
  - 300 : Cable L = 300 mm
  - 600 : Cable L = 600 mm
  - 1000 : Cable L = 1000 mm

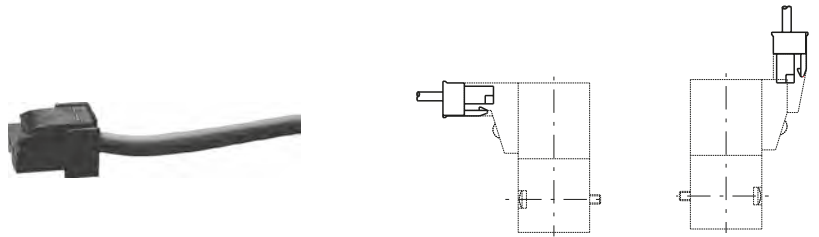

Weight 3 gr.

Closing plate

Ordering codes

395.00

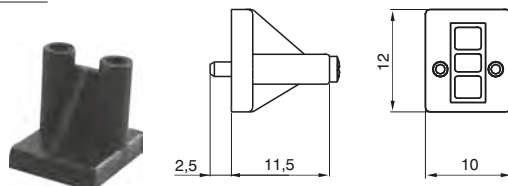

Weight 5 gr.

Interfaces dimensions

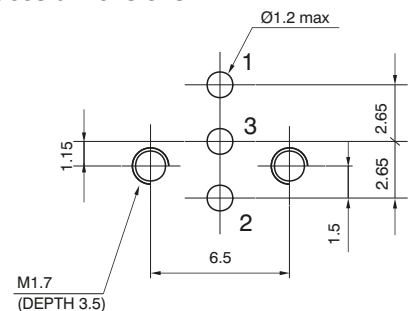

**10 mm - ISO 15218-2003 miniature solenoid ordering codes**

The versions are not contemplated by the CE Directive

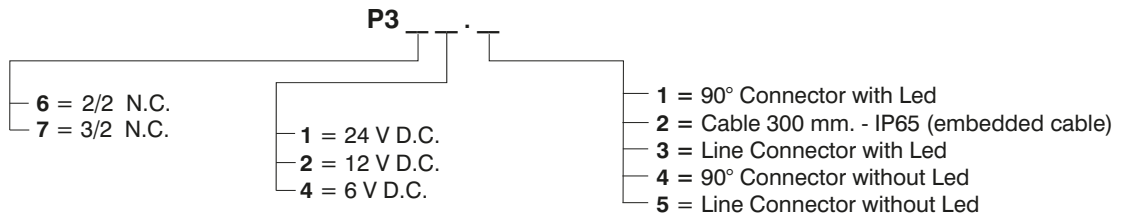

1 AIR DISTRIBUTION

**Miniature solenoid valve with cable**



Weight 12 gr.

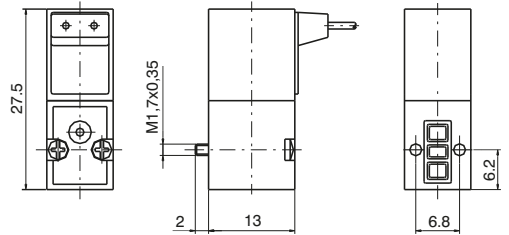

**Miniature solenoid valve with 90° connector**



Weight 12 gr.

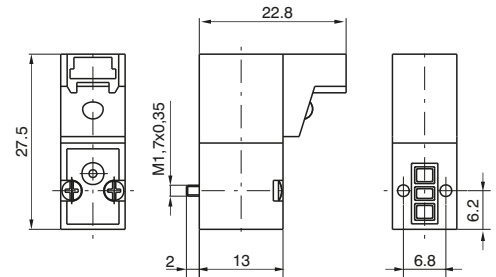

**Miniature solenoid valve with line connector**



Weight 12 gr.

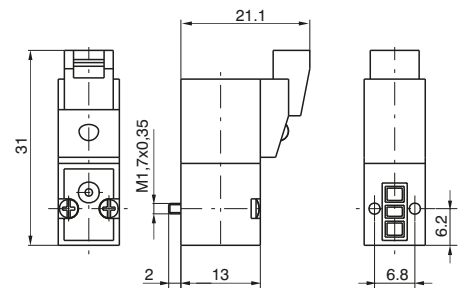

**Connector**

Ordering codes

371 .

- 300 : Cable L = 300 mm
- 600 : Cable L = 600 mm
- 1000 : Cable L = 1000 mm

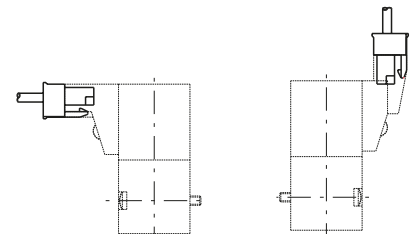

Weight 3 gr.

**Interfaces dimensions 10 mm - ISO 15218**

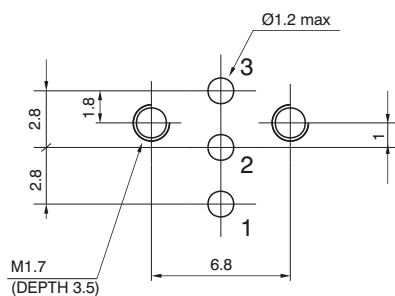

**Standard version  
Individual base**

Ordering code

**395.01**

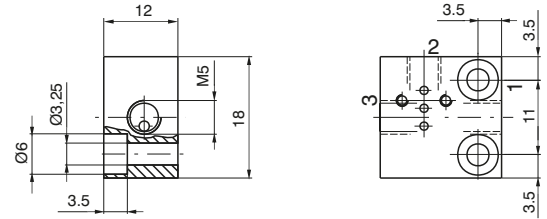

Weight 10 gr.

**Standard version  
multiple bases**

Ordering code

**395 .**

N° Places

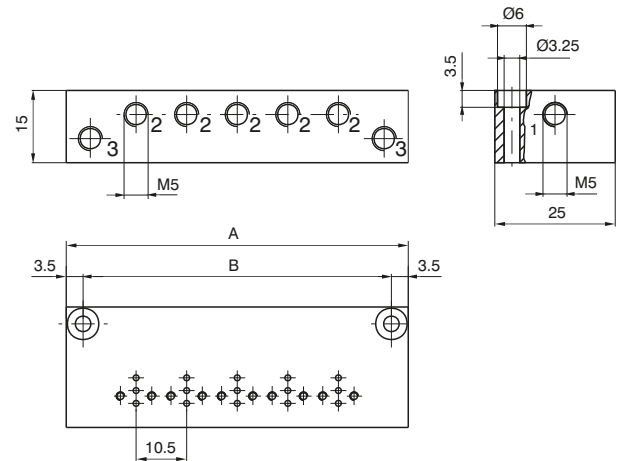

N° Places	02	03	04	05	06	07	08	09	10
A	39.5	50	60.5	71	81.5	92	102.5	113	123.5
B	32.5	43	53.5	64	74.5	85	95.5	106	116.5
Weight (gr.)	43	54	65	76	87	98	109	120	131

**Individual base for  
ISO 15218-2003 version**

Ordering code

**P395.01**

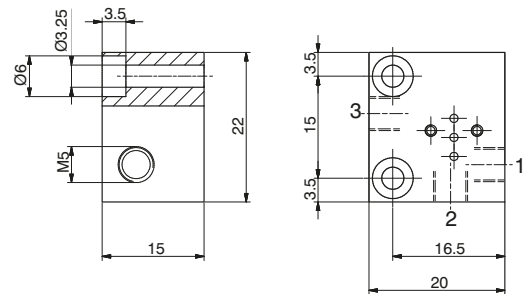

Weight 10 gr.

**Multiple base for  
ISO 15218-2003 version**

Ordering code

**P395 .**

N° Places

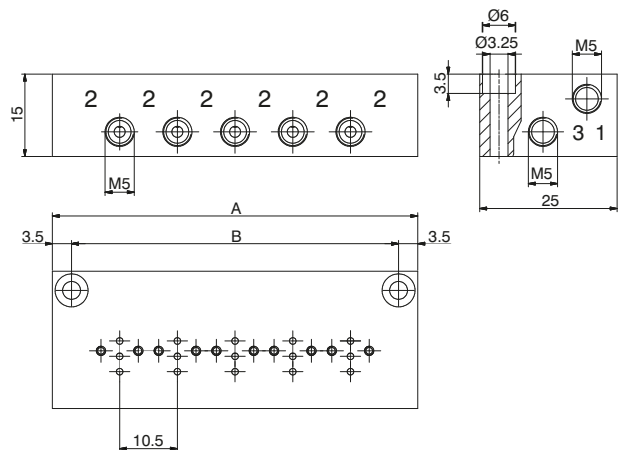

N° Places	02	03	04	05	06	07	08	09	10
A	35	45.5	56	66.5	77	87.5	98	108.5	119
B	28	38.5	49	59.5	70	80.5	91	101.5	112
Weight (gr.)	43	54	65	76	87	98	109	120	131



## Direct operated solenoid valves Series 300

This direct operated solenoid valve has minimum overall dimensions (15 mm wide). Its construction method is same as 10 mm valve, of course. It is suitable to be single or gang mounted or as electro-operator for larger air flow distributors. Can be utilized with compressed air and other fluids compatible with material used to build the solenoid valve. The available versions, all equipped with manual override, are 3 ways, normally closed and normally open with DC and AC 50/60 Hz. It's possible to install the N.O. valve on N.C. interface by using the registered reverse system included in the valve body. The electrical connection is made with cables (300 mm.), FASTON or with connector. This type of miniature solenoid valve is interchangeable with most of the same products available on the market. Make sure that the fastening screws are tightened with maximum torque of 0,75 Nm.

1  
AIR DISTRIBUTION

### Constructive features

Normally Closed (N.C.) 3/2

Normally Open (N.O.) 3/2

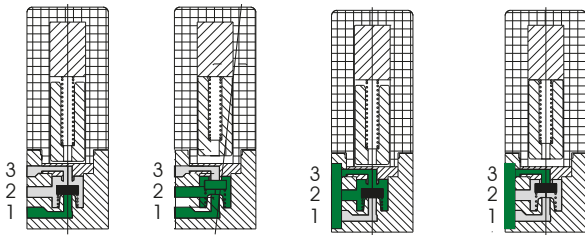

- 1 = SUPPLY PORT
- 2 = OUTLET PORT
- 3 = EXHAUST PORT

### Construction characteristics

#### Electrical part

Miniature solenoid consisting of a coil made of copper wire of different diameters depending on voltage, isolated according to "F" class standard, with injection-moulded nylon-glass application. All parts forming the cladding, the electrical connections and the pole pieces are protected against corrosion.

#### Mechanical part

AISI 430F cores, AISI 302 return springs, FPM poppets, thermoplastic polyester body.

### Technical characteristics

Pneumatic			
Orifice size (mm)	0.8	1.1	1,5 (only D.C.)
Flow rate at 6 bar with $\Delta p=1$ (NI/min)	20	30	50
Working pressure for N.C.	0 ... 10		0 ... 7
Working pressure for N.O.	/	0 ... 8	0 ... 5
Temperature °C	-5° ... +50°C		
Max number of cycles per minute (millions)	50 (with standard working conditions)		
Compressed air, purity class according to ISO 8573-1:2010	5:4:4		
Elettriche			
Voltage D.C.	24 VDC	12 ... 24 VDC	
Voltage A.C.	/	24-110-230 Volt 50/60 Hz	/
Power consumption D.C.	1 Watt	2,3 Watt	
Power consumption A.C.	/	2,8 VA (at starting) 2,5 VA (at speed)	/
Voltage tolerance	-5% ... +10%		
Response time *	10 ... 12		
Isolating class	F (155°C)		
Protection degree	IP65 (with cables), IP40 (with connectors), IP00 (with Faston)		

\*Shifting time of pneumatic directional control valves or moving parts, logic devices were measured in accordance to ISO 12238:2001"

15 mm miniature solenoid ordering codes

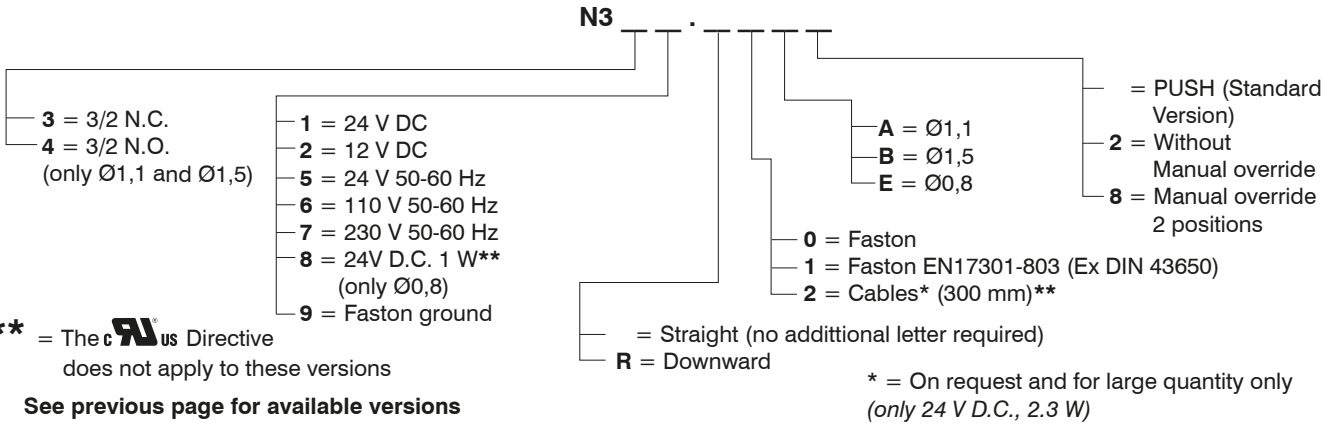

\*\* = The CE Directive does not apply to these versions

See previous page for available versions

With Faston



Weight 36 gr.

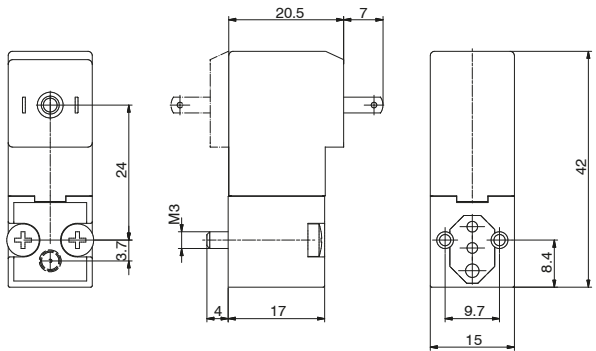

With Faston EN17301-803 (Ex DIN 43650)



Weight 36 gr.

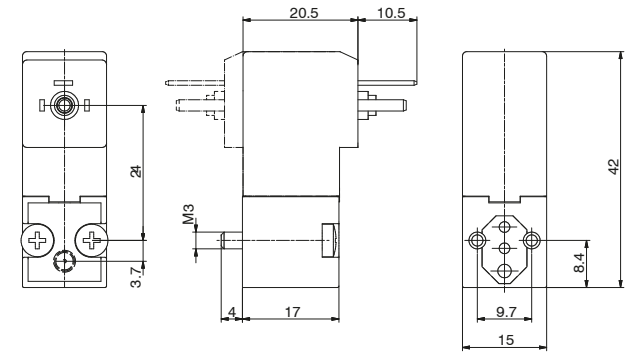

With Cables (300 mm)

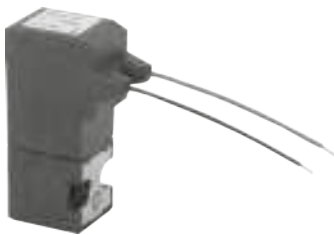

Weight 38 gr.

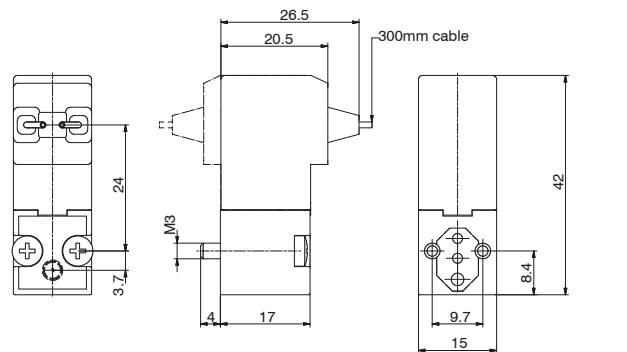

With Faston ground



Weight 38 gr.

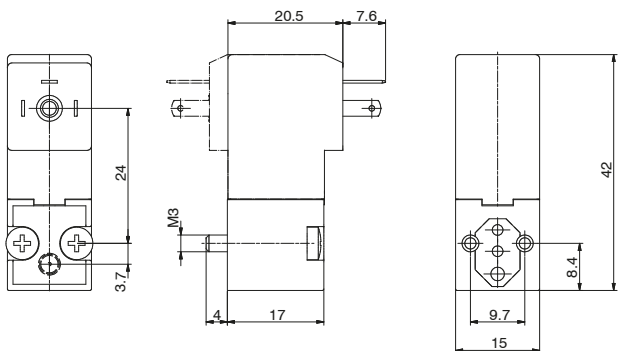

1  
AIR DISTRIBUTION

**Connector**

Ordering code

- 315.11.00** Standard
- 315.12.00** for faston EN17301-803 (Ex DIN 43650)
- 315.11.0 L** Led
  - 1 = 24 V D.C. / A.C.
  - 2 = 110 V 50/60 Hz
  - 3 = 230 V 50/60 Hz
- 315.12.0 L** for faston EN17301-803 (Ex DIN 43650) with Led
  - 1 = 24 V D.C. / A.C.
  - 2 = 110 V 50/60 Hz
  - 3 = 230 V 50/60 Hz

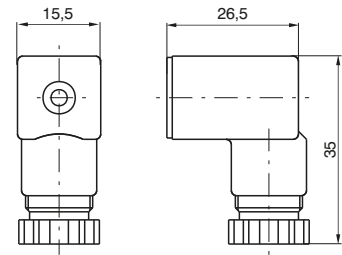

Weight 13 gr.

**Single use base**

Ordering code

**355.01**

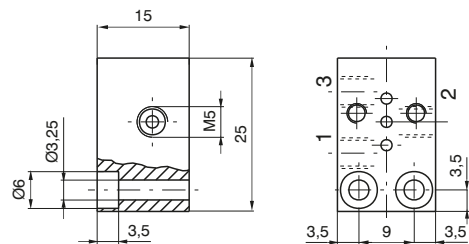

Weight 18 gr.

**Multiple bases**

Ordering code

A = Orifice M5

A = Pipe fitting Ø4

**355 .**

**354 .**

N° PLACES

N° PLACES

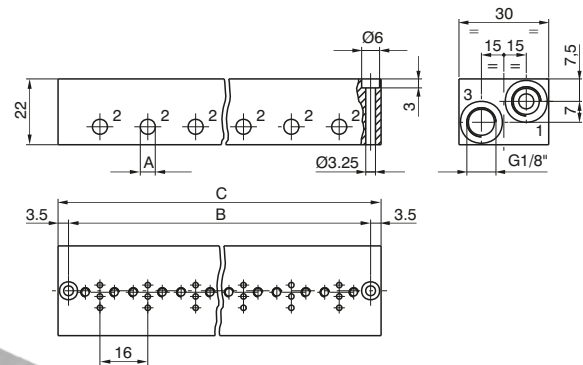

N° places	02	03	04	05	06	07	08	09	10
B	37	53	69	85	101	117	133	149	165
C	44	60	76	92	108	124	140	156	172
Weight (gr.)	66	92	116	141	165	190	216	242	266

**Closing plate**

Ordering code

**355.00**



Weight 6 gr.

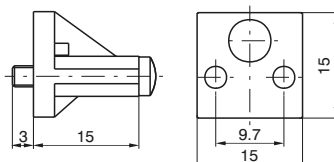

**Interface dimensions**

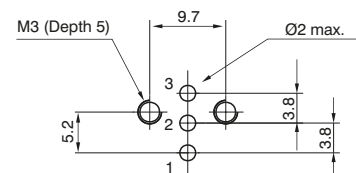

## 15mm Solenoid valves Manifold with electric multipoint connection

### General

Also for this 15mm solenoid valves series we have realized the possibility of the assembling on the base with multipoint connection, this for making faster the connection and the harness of them.

Realized from a shaped outline, it results compact because it uses a relevant multipoint connection available only with a 37 poles connector from 10 to 32 solenoid valves (with steps of 2), available in line or at 90° and IP40 protection. On the base it is possible to put some threaded cartridges with push-in fittings for Ø3 – Ø3,17 Ø4 tube or M5 threaded.

The application field of these new configurations is the standard of 3/2 valves, where it is needed to realize groups or Manifolds provided with integrated electric connection to make easier and faster the connection and the harness of them (control of single acting cylinders with small dimensions, pilot system of valves with bigger dimensions etc..).

### Constructive characteristics:

#### Constructive principle:

From 10 up to 32 solenoid valves (with steps of 2)

Extremely compact solution

IP40 protection (without visualisation led)

Possibility of having different working connections (Ø3, Ø3,17, Ø4 tubes, M5)

The new coding key requires the use of the same type of solenoid valves (there aren't codes for groups with a mixed configuration).

### Overall dimensions

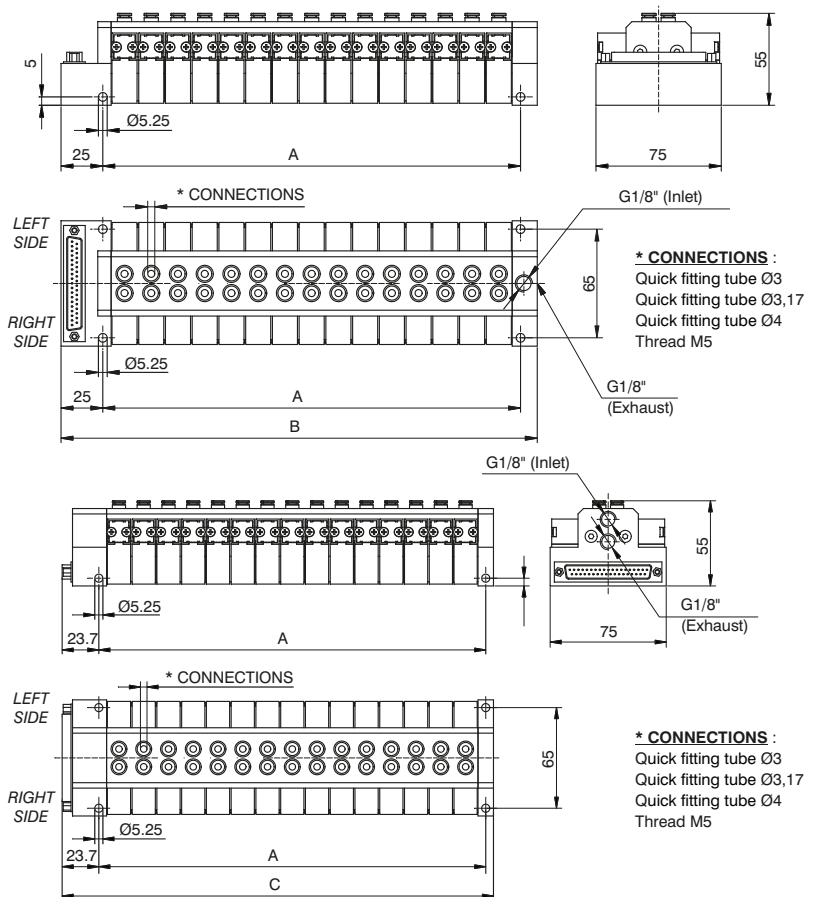

N° places	A	B	C
10	90	125	118,7
12	106	141	134,7
14	122	157	150,7
16	138	173	166,7
18	154	189	182,7
20	170	205	198,7
22	186	221	214,7
24	202	237	230,7
26	218	253	246,7
28	234	269	262,7
30	250	285	278,7
32	266	301	294,7

### SUB-D 37 POLES CONNECTORS

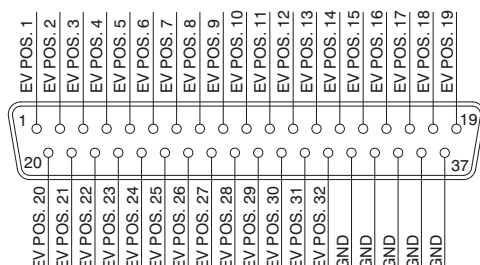

Overall dimensions  
Manifold with CANopen® node

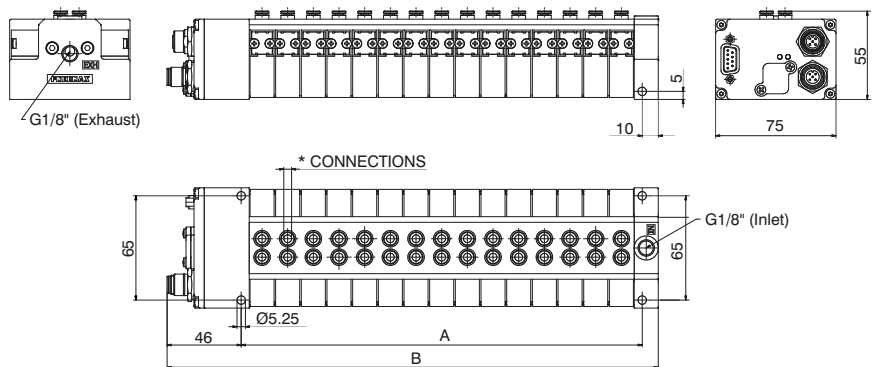

N° positions	A	B
10	90	146
12	106	162
14	122	178
16	138	194
18	154	210
20	170	226
22	186	242
24	202	258
26	218	274
28	234	290
30	250	306
32	266	322

Manifold layout configuration

Connector type  
**0** = in line connector  
**9** = 90° connector  
**C** = with CANopen® node

Connections size and type  
**3** = quick fitting tube Ø3  
**C** = quick fitting tube Ø3.17  
**4** = quick fitting tube Ø4  
**A** = M5 thread

**35M . NW . . . 0 . . . . .**

N° positions  
**A** = 10 positions  
**B** = 12 positions  
**C** = 14 positions  
**D** = 16 positions  
**E** = 18 positions  
**F** = 20 positions  
**G** = 22 positions  
**H** = 24 positions  
**L** = 26 positions  
**M** = 28 positions  
**N** = 30 positions  
**P** = 32 positions

N° positions  
 plugged side left  
**0** = 00 positions  
**1** = 01 positions  
**2** = 02 positions  
**3** = 03 positions  
**4** = 04 positions  
**5** = 05 positions  
**6** = 06 positions  
**7** = 07 positions  
**8** = 08 positions  
**9** = 09 positions  
**A** = 10 positions  
**B** = 11 positions  
**C** = 12 positions  
**D** = 13 positions  
**E** = 14 positions  
**F** = 15 positions  
**G** = 16 positions

N° positions  
 plugged side right  
**0** = 00 positions  
**1** = 01 positions  
**2** = 02 positions  
**3** = 03 positions  
**4** = 04 positions  
**5** = 05 positions  
**6** = 06 positions  
**7** = 07 positions  
**8** = 08 positions  
**9** = 09 positions  
**A** = 10 positions  
**B** = 11 positions  
**C** = 12 positions  
**D** = 13 positions  
**E** = 14 positions  
**F** = 15 positions  
**G** = 16 positions

Valve type  
**A** = N331.R0A (EV. 3/2 NC 24VDC d.1,1)  
**B** = N331.R0B (EV. 3/2 NC 24VDC d.1,5)  
**C** = N338.R0E (EV. 3/2 NC 24VDC 1W d.0,8)  
**D** = N341.R0A (EV. 3/2 NO 24VDC d.1,1)  
**E** = N341.R0B (EV. 3/2 NO 24VDC d.1,5)  
**F** = N335.R0A (EV. 3/2 NC 24VAC d.1,1)

**NOTE:**  
 The "R" letter indicates that the coil is mounted upside-down (faces down). For prices and technical features of these valves please refer to the correspondent standard version (not R) included in the price list and catalogue.



Overall dimensions

Manifold with Optyma-F serial system (slave + input modules)

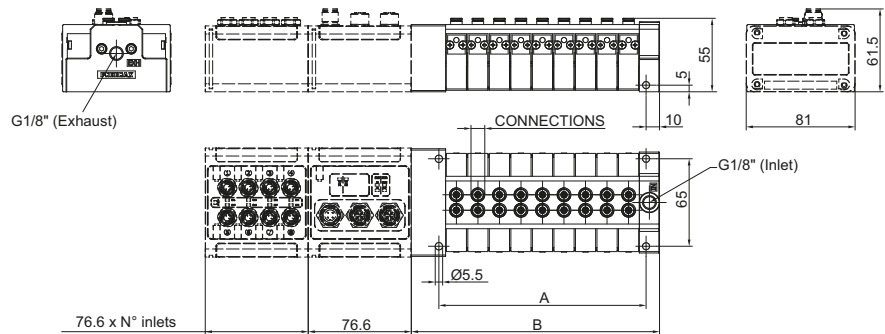

N° positions	A	B
10	90	120,50
12	106	136,50
14	122	152,50
16	138	168,50
18	154	184,50
20	170	200,50
22	186	216,50
24	202	232,50
26	218	248,50
28	234	264,50
30	250	280,50
32	266	296,50

Manifold layout configuration with Optyma-F serial system (slave + input modules)

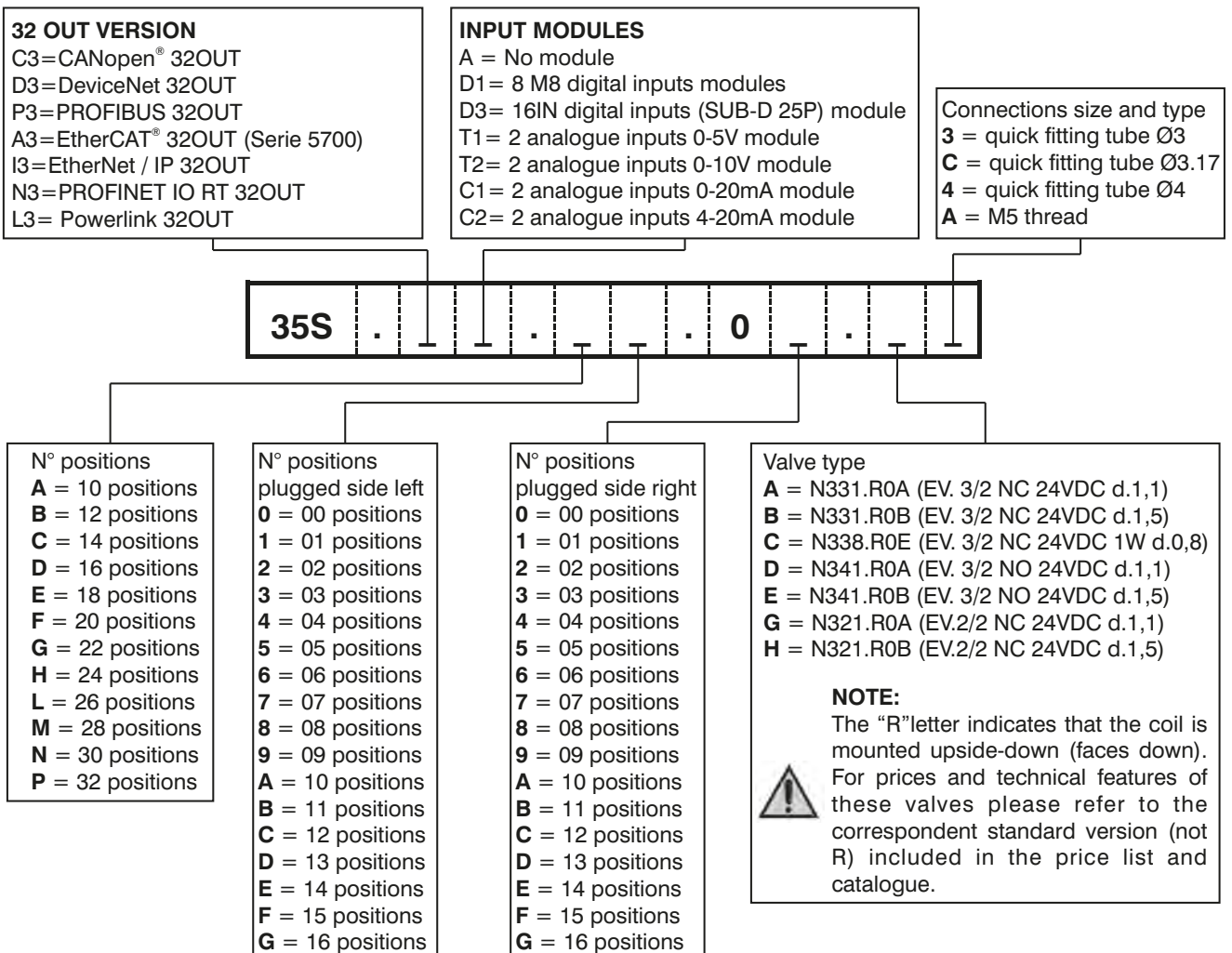

Functional schematics

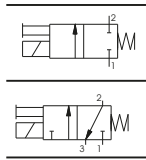

- 1 = INLET PORT
- 2 = OUTLET PORT
- 3 = EXHAUST PORT  
(Plugged if 2/2)

Normally Closed (N.C.) 3/2 or 2/2

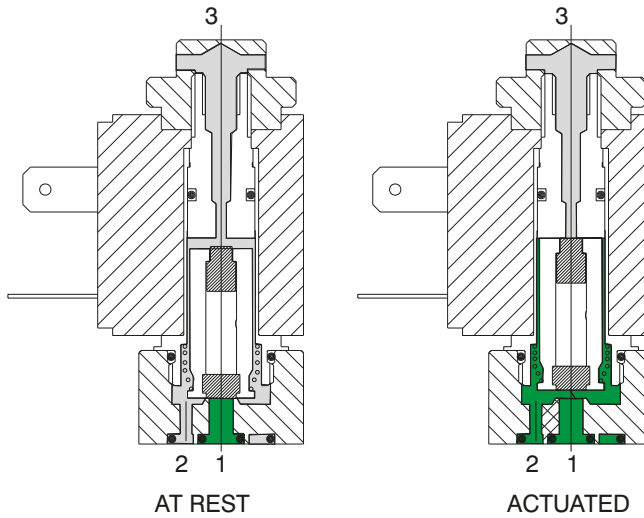

Normally Open (N.O.) 3/2 or 2/2

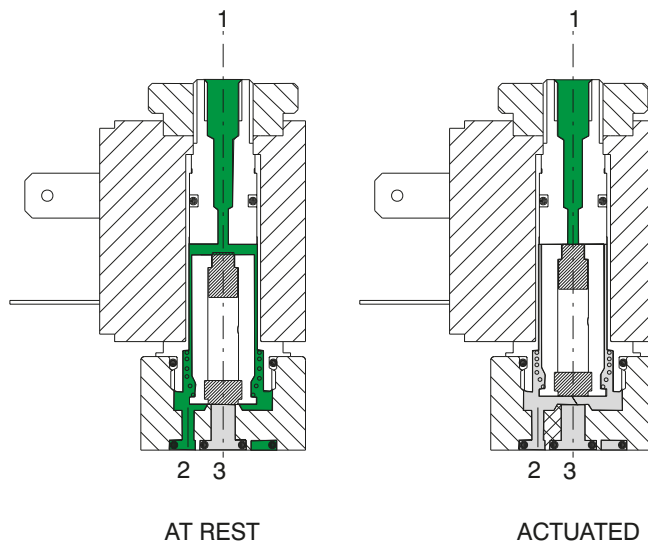
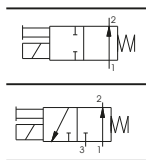

Construction characteristics

**Electrical parts:** Solenoids: the solenoid consist of coils having different diameter copper wire windings insulated according standards "H"; they are encased in a nylon-glass compound. All parts are corrosion resistant.

**Mechanical parts:** Nickel plated brass tube nitrile viton seals stainless steel plunger (AISI 430F), stainless steel adjusted springs, viton poppet seals, tropicalized zinc alloy interface plate, nickered brass manual override, nickel steel coil lock nut, zinc steel mounting screw. To be usable, the solenoids and microsolenoids have to be attached either to a base or directly to the distributor's operators by means of connectors M5 or G 1/8". These solenoids are available in all voltages and frequencies used in the world. The following are the technical characteristics of the solenoid.

1 AIR DISTRIBUTION



## Technical characteristics

<b>Pneumatic</b>	Working pressure	0 - 10 bar	
	Orifice size	1,3 mm	(0,9 mm for 2 W)
	Maximum fluid temperature	50°C	
	Maximum ambient temperature	50°C	
	Maximum flow rate at 6 bar with $\Delta p$ 1 bar	53 NI/min	(20NI/min. for 2 W)
	Cycles/minute	700	
	Fluids	Air-vacuum-inert gases	
	Lubrication	non required	
Life	45 to 50 million cycles		
<b>Electrical</b>	Power consumption holding - D.C	5 W	(2.5 W) low consumption
	Power consumption holding - A.C	9 VA	(6 VA) low consumption
	Operating voltage tolerance	$\pm 10\%$	
	Response time opening *	8 ms	
	Response time closing *	6 ms	
	Insulation of the copper wire	H	
	Insulation of the coil	F	
	Connector protection	IP 65	
Cable protection	DIN 43650 INDUSTRIAL FORM		

(\*) "Shifting time of pneumatic directional control valves or moving parts, logic devices were measured in accordance to ISO 12238:2001, Pneumatic fluid power - Directional control valves - Measurement of shifting time"

## Maintenance and replacement parts

Maintenance practices for these valves are similar to those already detailed for other products- replacement of the plunger or poppet is not advisable since the new replacement would not provide the best fit with the rest of the already used valve. Special care should be taken that no dirt is accumulated between the working surface of fixed core and the plunger which would result in vibrations and overheating of the solenoid. In the case of microsolenoid it must be assured that the alternate current coil is not charged when the mechanical part is not mounted to avoid destruction of the coil. The electrical connections have to be perfect, especially where low currents are used (12-24V). Oxidation of contacts between the connector and the coil can lead to intermittent malfunctions which are difficult to trace. Oxidation of contacts due to humidity or corrosive atmosphere are one of the most common causes of false alarms. Clean the contacts with appropriate spray.

Mechanical actuator for miniature solenoid valve

Ordering code

- M 2** Normally Closed (N.C.)
- M 2P** Normally Closed (N.C.) threaded lock nut
- M 2/9** Normally Closed (N.C.) 2 W 24 VDC

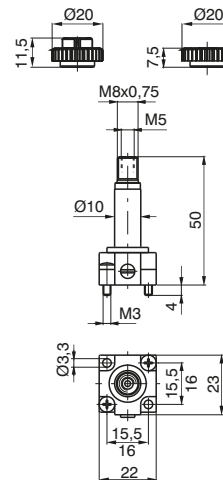
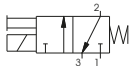

Weight 51 gr.

- M 2/1** Normally Open (N.O.) air feeding through fix flunger

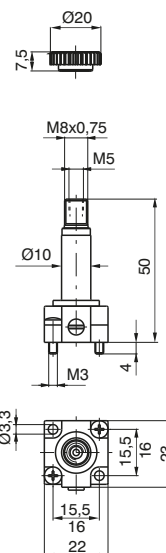
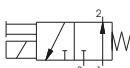

Weight 48 gr.

- Normally Open (N.O.) air feeding through base

**MM 7**

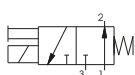

Weight 46 gr.

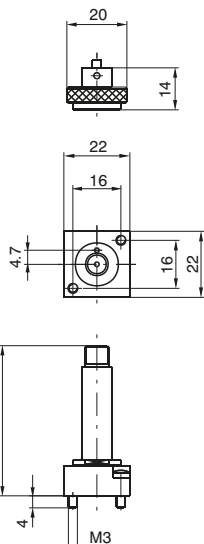

Ordering code	Available voltages	
N.O.	Coil	
<b>MB10/1</b>	24 D.C. (8 Watt)	Direct current
<b>MB17/1</b>	24/50	Alternating current 50 Hz
<b>MB21/1</b>	48/50	
<b>MB22/1</b>	110/50	
<b>MB24/1</b>	230/50	
<b>MB37/1</b>	24/60	Alternating current 60 Hz
<b>MB39/1</b>	110/60	
<b>MB41/1</b>	230/60	
<b>MB56/1</b>	24/50-60	Alternating current 50/60 Hz
<b>MB57/1</b>	110/50-60	
<b>MB58/1</b>	230/50-60	

**Coil**

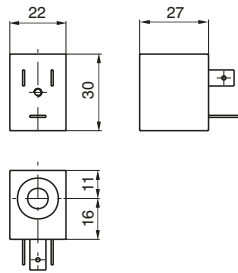

Weight 54 gr.

\* Use only with M2/9

Ordering code	Available voltages Coils
<b>MB 4</b> <b>MB 5</b> <b>MB 6</b>	12 D.C. 24 D.C. 48 D.C. Direct current
<b>MB 9*</b>	24 D.C. (2 Watt) (Direct current, low consumption)
<b>MB 17</b> <b>MB 21</b> <b>MB 22</b> <b>MB 24</b>	24/50 48/50 110/50 230/50 Alternating current 50 Hz
<b>MB 37</b> <b>MB 39</b> <b>MB 41</b>	24/60 110/60 230/60 Alternating current 60 Hz
<b>MB 56</b> <b>MB 57</b> <b>MB 58</b>	24/50-60 110/50-60 230/50-60 Alternating current 50/60 Hz
<b>MB 66</b> <b>MB 67</b> <b>MB 68</b>	24/50-60 110/50-60 230/50-60 Alternating current (low consumption) 50/60 Hz

**Miniature solenoid valve Normally Closed (N.C.)**

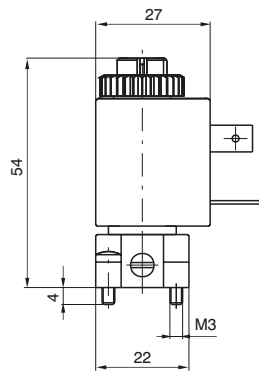
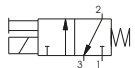

Weight 100 gr.

Ordering code	Available voltages Miniature solenoid valve N.C.
<b>M 2.4</b> <b>M 2.5</b> <b>M 2.6</b> <b>M 2.9</b>	12 D.C. 24 D.C. 48 D.C. 24 D.C. (2 Watt) Direct current
<b>M 2.17</b> <b>M 2.21</b> <b>M 2.22</b> <b>M 2.24</b>	24/50 48/50 110/50 230/50 Alternating current 50 Hz
<b>M 2.37</b> <b>M 2.39</b> <b>M 2.41</b>	24/60 110/60 230/60 Alternating current 60 Hz
<b>M 2.56</b> <b>M 2.57</b> <b>M 2.58</b>	24/50-60 110/50-60 230/50-60 Alternating current 50/60 Hz
<b>M 2.66</b> <b>M 2.67</b> <b>M 2.68</b>	24/50-60 110/50-60 230/50-60 Alternating current (low consumption) 50/60 Hz

**Miniature solenoid valve Normally Open (N.O.)**

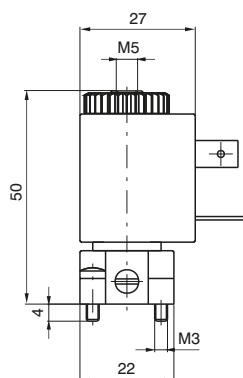
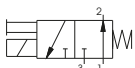

Weight 103 gr.

Ordering code	Available voltages Miniature solenoid valve N.O.
<b>M 2/1.4</b> <b>M 2/1.5</b> <b>M 2/1.6</b> <b>M 2/1.9</b>	12 D.C. 24 D.C. 48 D.C. 24 D.C. (2 Watt) Direct current
<b>M 2/1.17</b> <b>M 2/1.21</b> <b>M 2/1.22</b> <b>M 2/1.24</b>	24/50 48/50 110/50 230/50 Alternating current 50 Hz
<b>M 2/1.37</b> <b>M 2/1.39</b> <b>M 2/1.41</b>	24/60 110/60 230/60 Alternating current 60 Hz
<b>M 2/1.56</b> <b>M 2/1.57</b> <b>M 2/1.58</b>	24/50-60 110/50-60 230/50-60 Alternating current 50/60 Hz

**External feeding base**

Use with solenoid valves for piloting pressure different from the using pressure

Ordering code

**305.10.05**

Weight 18 gr.

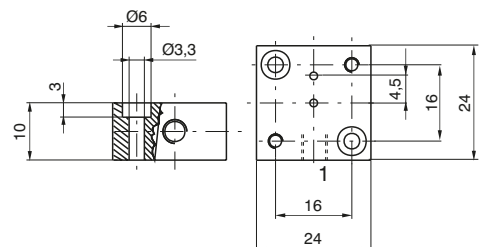
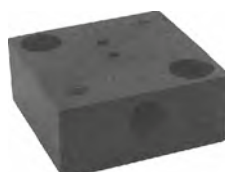

Individual base

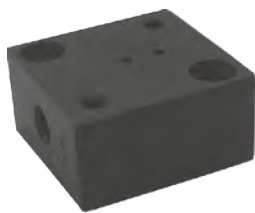

In line ports - thread M5

1 = INLET PORT (N.C.)  
2 = OUTLET PORT

With a N.O. miniature solenoid valve  
1 = EXHAUST  
2 = OUTLET PORT

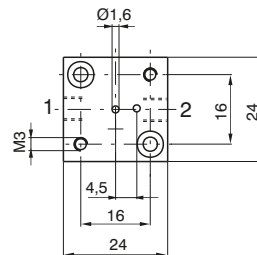
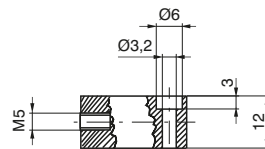

Ordering code

305.00.00

Weight 56 gr.

AIR DISTRIBUTION

1



90° Port - thread M5

1 = INLET PORT (N.C.)  
2 = OUTLET PORT (N.C.)

With a N.O. miniature solenoid valve  
1 = EXHAUST  
2 = OUTLET PORT

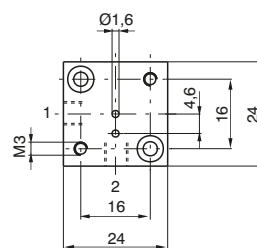
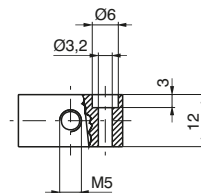

Ordering code

305.90.00

Weight 56 gr.

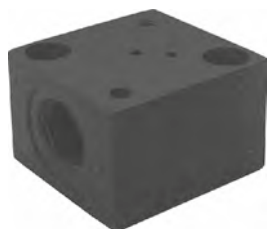

In line ports - thread G 1/8"

1 = INLET PORT (N.C.)  
2 = OUTLET PORT (N.C.)

With a N.O. miniature solenoid valve  
1 = EXHAUST  
2 = OUTLET PORT

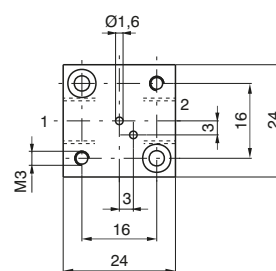
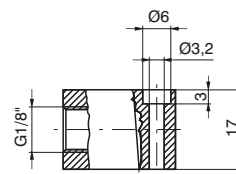

Ordering code

305.00.18

Weight 75 gr.



90° Port - thread G 1/8"

1 = INLET PORT (N.C.)  
2 = OUTLET PORT (N.C.)

With a N.O. miniature solenoid valve  
1 = EXHAUST  
2 = OUTLET PORT

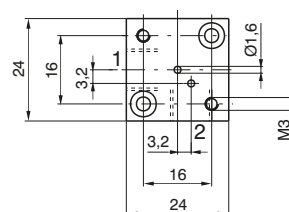
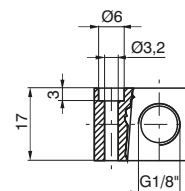

Ordering code

305.90.18

Weight 75 gr.

Modular bases for series mounting

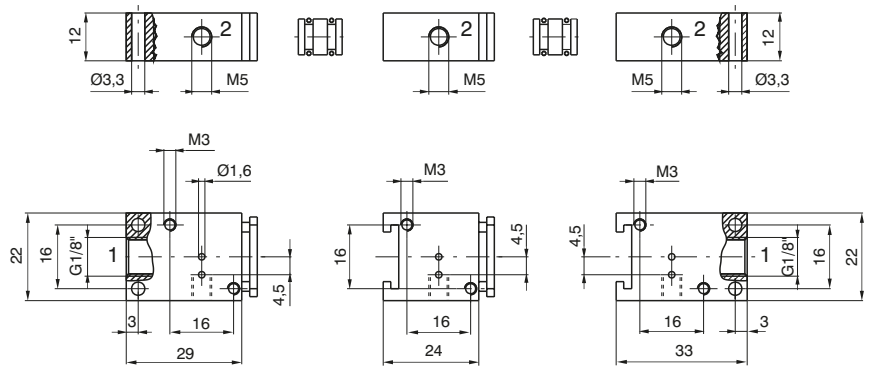

Ordering code

Initial base  
**305.05.00**  
Weight 57 gr.

Intermediate base  
**305.06.00**  
Weight 44 gr.

Last base  
**305.07.00**  
Weight 53 gr.

Bored spacer  
**305.05.01**  
Weight 3 gr.

Solid spacer  
**305.05.02**  
Weight 4 gr.

Initial base

Intermediate base

Last base



Multiple integral bases for series mounting

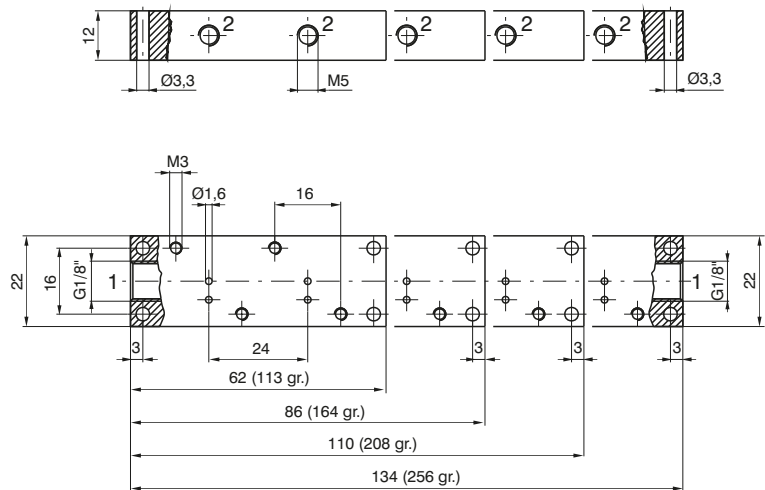

Ordering code

**305.08.02** 2 positions  
**305.08.03** 3 positions  
**305.08.04** 4 positions  
**305.08.05** 5 positions

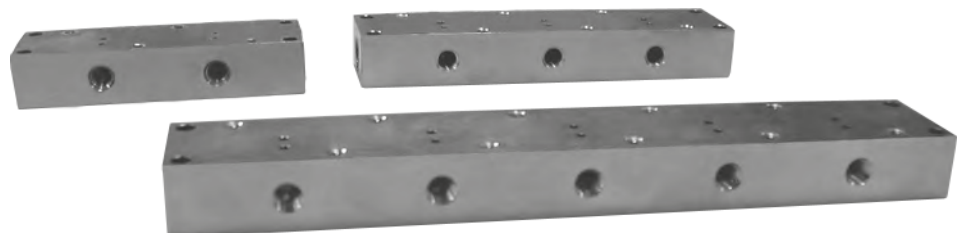

**Functional schematic**

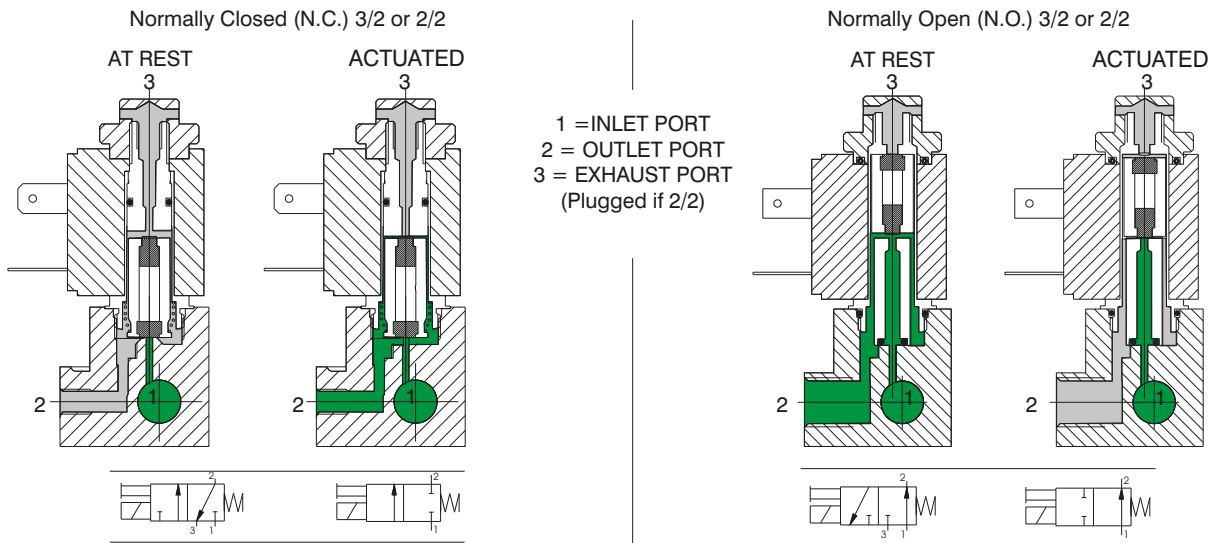

**Construction characteristics**

**Electrical parts:** Solenoids: the solenoid consist of coils having different diameter copper wire windings insulated according standards "H"; they are encased in a nylon-glass compound. All parts are corrosion resistant.

**Mechanical parts:** Nickel plated brass tube nitrile (NBR) stainless steel plunger (AISI 430F), stainless steel adjusted springs, viton poppet seals, tropicalized zinc alloy interface plate, nickered brass manual override, Technopolymer coil lock nut, zinc steel mounting screws. Electrical connectors are standard.

**Technical characteristics**

<b>Pneumatic</b>	Working pressure	0 - 10 bar	
	Orifice size	1,3 mm	(1,1 mm for 2 W)
	Maximum fluid temperature	50°C	
	Maximum ambient temperature	50°C	
	Maximum flow rate at 6 bar with $\eta_p = 1$	53 NI/min	(35 NI/min. for 2 W)
	Cycles/minute	700	
	Fluids	Air-Vacuum-Inert gases	
	Lubrication	Non needed	
	Life	40 to 50 million cycles	
	<b>Electrical</b>	Power consumption holding - D.C	5 W
Power consumption holding - A.C		8 VA	(6 VA) low consumption
Operating voltage tolerance		$\pm 10\%$	
Response time opening *		8 ms	
Response time closing *		6 ms	
Insulation of the copper wire		H	
Insulation of the coil		F	
Connector protection		IP 65	
Cable protection		DIN 43650 INDUSTRIAL FORM	

(\*) "Shifting time of pneumatic directional control valves or moving parts, logic devices were measured in accordance to ISO 12238:2001, Pneumatic fluid power - Directional control valves - Measurement of shifting time"

**Maintenance and replacement parts**

Maintenance practices for these valves are similar to those already detailed for other products - replacement of the plunger or poppet is not advisable since the new replacement would not provide the best fit with the rest of the already used valve.

Special care should be taken that no dirt is accumulated between the working surface of fixed core and the plunger which would result in vibrations and overheating of the solenoid. In the case of microsolenoid it must be assured that the alternate current coil is not charged when the mechanical part is not mounted to avoid destruction of the coil.

The electrical connections have to be perfect, especially where low currents are used (12-24 V). Oxidation of contacts between the connector and the coil can lead to intermittent malfunctions which are difficult to trace. Oxidation of contacts due to humidity or corrosive atmosphere are one of the most common causes of false alarms. Clean the contacts with appropriate spray.



**Mechanical actuator for Normally Closed (N.C.)  
Miniature solenoid valve**

Normally Closed (N.C.)

Ordering code

- 305.M1 A = G 1/8"
- 355.M1 A = M5
- 345.M1 A = Push in fitting for 4 mm tube

- 305.M1/9 A = G 1/8"
- 355.M1/9 A = M5
- 345.M1/9 A = Push in fitting for 4 mm tube

2 W  
24 DC

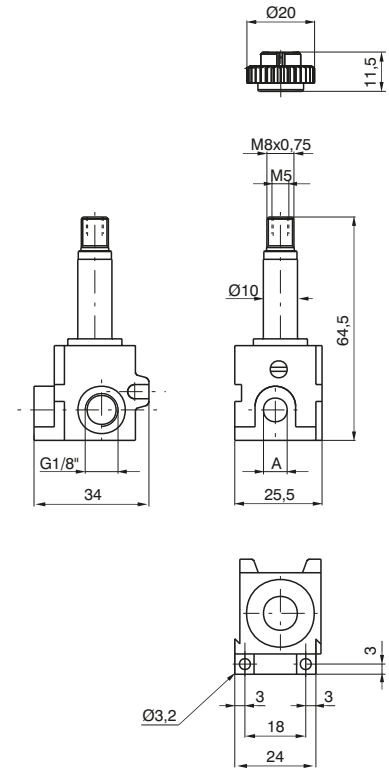

Weight 95 gr.

Normally Open (N.O.)

Ordering code

- 305.M1/1 A = G 1/8"
- 355.M1/1 A = M 5
- 345.M1/1 A = Push in fitting for 4 mm tube

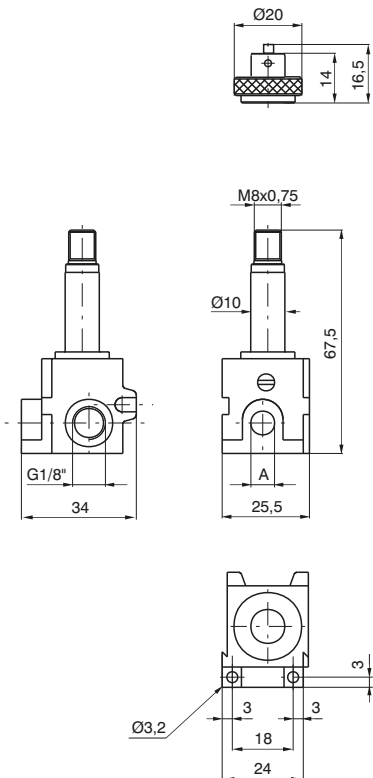

Weight 106 gr.

1  
AIR DISTRIBUTION

Miniature solenoid valve

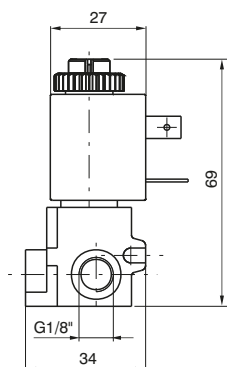

Normally Closed (N.C.)

Weight 149 gr.

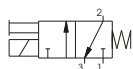

Ordering code			Available voltage miniature solenoid	
G 1/8"	M5	TUBE Ø4 mm		
<b>305.M4</b>	<b>355.M4</b>	<b>345.M4</b>	12 D.C.	Direct current
<b>305.M5</b>	<b>355.M5</b>	<b>345.M5</b>	24 D.C.	
<b>305.M6</b>	<b>355.M6</b>	<b>345.M6</b>	48 D.C.	
<b>305.M9</b>	<b>355.M9</b>	<b>345.M9</b>	24 D.C. (2 Watt)	
<b>305.M17</b>	<b>355.M17</b>	<b>345.M17</b>	24/50	Alternating current 50 Hz
<b>305.M21</b>	<b>355.M21</b>	<b>345.M21</b>	48/50	
<b>305.M22</b>	<b>355.M22</b>	<b>345.M22</b>	110/50	
<b>305.M24</b>	<b>355.M24</b>	<b>345.M24</b>	230/50	
<b>305.M37</b>	<b>355.M37</b>	<b>345.M37</b>	24/60	Alternating current 60 Hz
<b>305.M39</b>	<b>355.M39</b>	<b>345.M39</b>	110/60	
<b>305.M41</b>	<b>355.M41</b>	<b>345.M41</b>	230/60	
<b>305.M56</b>	<b>355.M56</b>	<b>345.M56</b>	24/50-60	Alternating current 50/60 Hz
<b>305.M57</b>	<b>355.M57</b>	<b>345.M57</b>	110/50-60	
<b>305.M58</b>	<b>355.M58</b>	<b>345.M58</b>	230/50-60	
<b>305.M66</b>	<b>355.M66</b>	<b>345.M66</b>	24/50-60	Alternating current low consumption 50/60 Hz
<b>305.M67</b>	<b>355.M67</b>	<b>345.M67</b>	110/50-60	
<b>305.M68</b>	<b>355.M68</b>	<b>345.M68</b>	230/50-60	

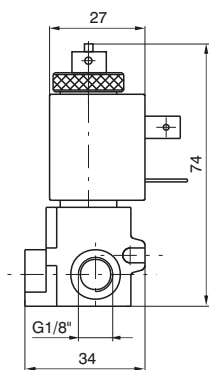

Normally Open (N.O.)

Weight 165 gr.

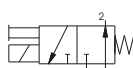

Ordering code			Available voltages miniature solenoid	
G 1/8"	M5	TUBE Ø4 mm		
<b>305.M10/1</b>	<b>355.M10/1</b>	<b>345.M10/1</b>	24 D.C. (8 Watt)	Direct current
<b>305.M17/1</b>	<b>355.M17/1</b>	<b>345.M17/1</b>	24/50	Alternating current 50 Hz
<b>305.M21/1</b>	<b>355.M21/1</b>	<b>345.M21/1</b>	48/50	
<b>305.M22/1</b>	<b>355.M22/1</b>	<b>345.M22/1</b>	110/50	
<b>305.M24/1</b>	<b>355.M24/1</b>	<b>345.M24/1</b>	230/50	
<b>305.M37/1</b>	<b>355.M37/1</b>	<b>345.M37/1</b>	24/60	Alternating current 60 Hz
<b>305.M39/1</b>	<b>355.M39/1</b>	<b>345.M39/1</b>	110/60	
<b>305.M41/1</b>	<b>355.M41/1</b>	<b>345.M41/1</b>	230/60	
<b>305.M56/1</b>	<b>355.M56/1</b>	<b>345.M56/1</b>	24/50-60	Alternating current 50/60 Hz
<b>305.M57/1</b>	<b>355.M57/1</b>	<b>345.M57/1</b>	110/50-60	
<b>305.M58/1</b>	<b>355.M58/1</b>	<b>345.M58/1</b>	230/50-60	

Coil



Weight 54 gr.

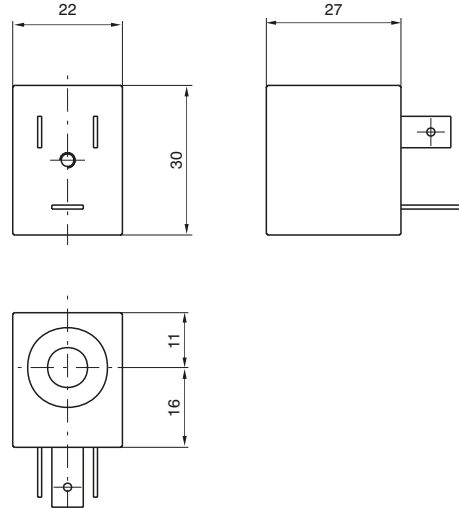

1  
AIR DISTRIBUTION

Ordering code		Available voltages Coil
N.C.	N.O.	
<b>MB4</b> <b>MB5</b> <b>MB6</b> <b>MB9</b>	<b>MB10/1</b>	12 D.C. 24 D.C. 48 D.C. 24 D.C. (2 Watt) 24 D.C. (8 Watt) Direct current
<b>MB17</b> <b>MB21</b> <b>MB22</b> <b>MB24</b>	<b>MB17/1</b> <b>MB21/1</b> <b>MB22/1</b> <b>MB24/1</b>	24/50 48/50 110/50 230/50 Alternating current 50 Hz
<b>MB37</b> <b>MB39</b> <b>MB41</b>	<b>MB37/1</b> <b>MB39/1</b> <b>MB41/1</b>	24/60 110/60 230/60 Alternating current 60 Hz
<b>MB56</b> <b>MB57</b> <b>MB58</b>	<b>MB56/1</b> <b>MB57/1</b> <b>MB58/1</b>	24/50-60 110/50-60 230/50-60 Alternating current 50/60 Hz
<b>MB66</b> <b>MB67</b> <b>MB68</b>	/	24/50-60 110/50-60 230/50-60 Alternating current (low consumption) 50/60 Hz

Electrical connector

Ordering code

**305.11.00** Normal

**305.11.0 L** with Led  
 1 = 24 V D.C. / A.C.  
 2 = 110 V 50/60 Hz  
 3 = 230 V 50/60 Hz

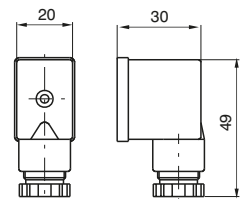

Weight 19 gr.

## BISTABLE

### General

The most interesting aspects of this bi-stable miniature solenoid valve operating with D.C. only, is that it can be commuted with a simple electric impulse and stay commuted till an inverted polarity impulse deactivates it. It means that the valve is not automatically deactivated if current fail as happens with normal solenoid valves.

The applications differ but are all based on above mentioned feature.

The internal construction is relatively special. The fix plunger is equipped with a permanent magnet that hold or release the mobile plunger according to the magnetic field generated by the coil.

A specific coil is used for this application and it cannot be replaced by the standard ones.

Ordering code is **MBB5**.

### Miniature solenoid valve for distributors and bases

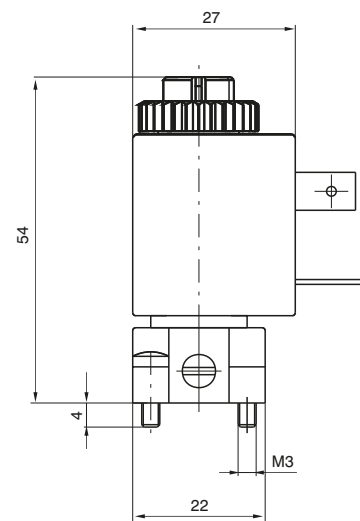

Ordering code

**M5/B**

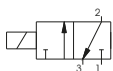

### Miniature solenoid valve with inseries mounting base

Ordering code

**305.M5/B** = G 1/8"

**355.M5/B** = M5

**345.M5/B** = Fitting for 4 mm tube

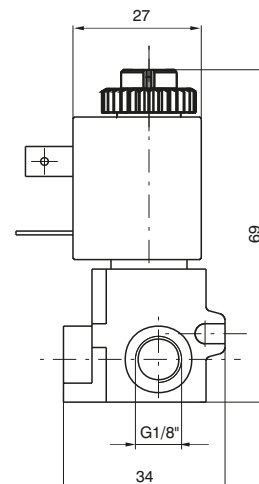

### Electric pilot CNOMO (coil not included)

Mechanics with base for solenoid to be used where an electric pilot system is required.

May be used on all sizes and is standardized as an interface on the distributor.

The base is fitted with a manual control which is pulse actuated, without check, or with two stable positions, actuated by means of a screwdriver (pressing down and turning clockwise by 90°). Two different types of solenoids can be mounted on the stem, one in conformity with ISO standard size 30x38 and ISO 4400 (DIN 43650) electrical connection, and a compact one size 22x27, having the same performance but at lower price. The technical characteristics of the latter are described in the catalogue, series 300, and refer to MB solenoids. The base is fitted with screws (M4x30) for fastening to the distributor.

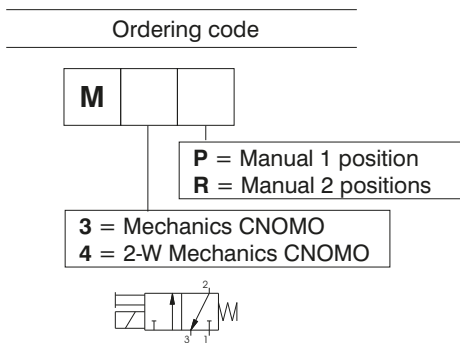

Weight 49 gr.

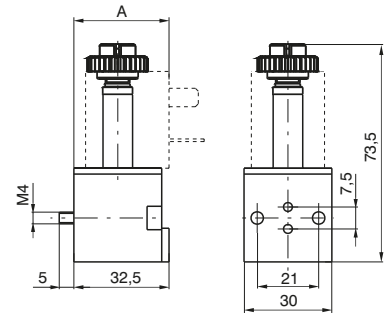

A = 33 (with MB solenoid)

A = 38 (with MC solenoid)

### General characteristics

<b>Structural</b>	Body	Thermoplastic polyester	
	Stem	Nickel-plated brass	
	Cores	AISI 430F stainless steel	
	Springs	AISI 302 stainless steel	
	Shutters	FPM	
	Other seals	NBR	
<b>Pneumatic</b>	Manual control	Nickel-plated brass	
	Fluid	Air, Neutral gases	
	Working pressure	0-10 bar	
	Fluid ambient temperature	-5°C - +50°C	
	Flow rate at 6 bar with Δp 1 bar	53 NI/min	(20 NI/min for 2 W)
	Nominal flow cross section	1,3 mm	(0,9 mm for 2 W)
<b>Electric</b>	Power consumption (inrush) - A.C.	13 VA	
	Power consumption holding - D.C.	4 W	(2 W)
	Power consumption holding - A.C.	8,5 VA	
	Operating voltage tolerance	±10%	
	Response time opening *	13 ms	
	Response time closing *	5 ms	
	Insulation of the copper wire	H	
	Insulation of the coil	F	
	Connector protection	IP 65	
	Cable protection	DIN 43650 "A" FORM	

(\*) "Shifting time of pneumatic directional control valves or moving parts, logic devices were measured in accordance to ISO 12238:2001, Pneumatic fluid power - Directional control valves - Measurement of shifting time"

### Coil

Ordering code	Available voltages
	Coil
MC5	24 D.C.
MC9	24 D.C. (2 Watt)
MC56	24/50-60 Hz
MC57	110/50-60 Hz
MC58	230/50-60 Hz



Weight 110 gr.

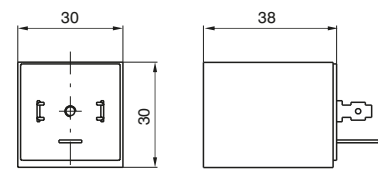

Functional schematic

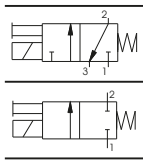

- 1 = INLET PORT
- 2 = OUTLET PORT
- 3 = EXHAUST PORT  
(Plugged if 2/2)

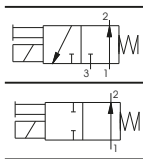

Normally Closed (N.C.) 3/2 or 2/2

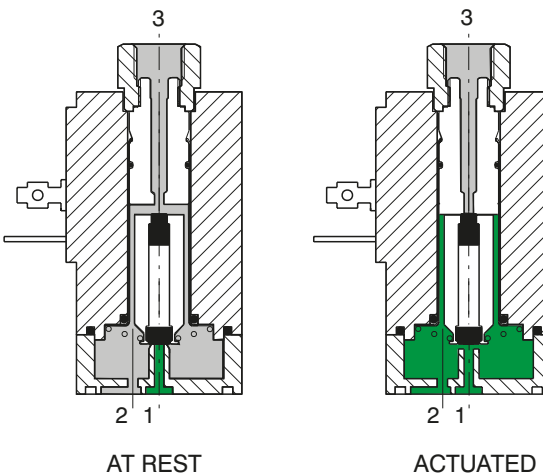

Normally Open (N.O.) 3/2 or 2/2

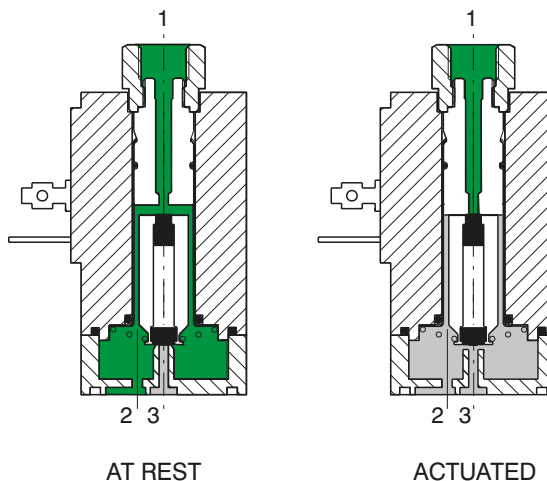

Construction characteristics

Electrical parts:

Solenoids: the solenoid consists of coils having different diameter copper wire windings insulated according standards "H"; they are encased in a nylon-glass compound. All parts are corrosion resistant.

Mechanical parts:

Stainless steel tube and plunger (AISI 430F), stainless steel adjusted springs, viton poppet seals, tropicalized zinc alloy interface plate, nitrile (NBR) seal nicked brass manual override, nickel steel coil lock nut, zinc steel mounting screws. To be usable, the solenoids have to be attached either to a base or directly to the distributor's operators by means of connectors G 1/8". Electrical connectors are standard. These solenoid are available in all voltages and frequencies used in the world. The following are the technical characteristics of the solenoid.

1 AIR DISTRIBUTION



### Technical characteristics

<b>Pneumatic</b>	Working pressure	0 - 10 bar
	Orifice size	1,8 mm
	Maximum fluid temperature	50°C
	Maximum ambient temperature	50°C
	Maximum flow rate at 6 bar with $\Delta p = 1$	80 NI/min
	Cycles/minute	700
	Fluids	Air-Vacuum-Inert gases
	Lubrication	Not required
	Life	40 to 50 millions
<b>Electric</b>	Power consumption (inrush) - D.C.	-
	Power consumption (inrush) - A.C.	19,5 VA
	Power consumption holding - D.C.	8,2 W
	Power consumption holding - A.C.	9 VA
	Operating voltage tolerance	$\pm 10\%$
	Response time opening *	15 ms
	Response time closing *	30 ms
	Insulation of the copper wire	H
	Insulation of the coil	F
	Connector protection	IP 65
	Cable protection	DIN 43650 "A" FORM

(\*): "Shifting time of pneumatic directional control valves or moving parts, logic devices were measured in accordance to ISO 12238:2001, Pneumatic fluid power - Directional control valves - Measurement of shifting time"

### Maintenance and replacement parts

Maintenance practices for these valves are similar to those already detailed for other products - replacement of the plunger or poppet is not advisable since the new replacement would not provide the best fit with the rest of the already used valve.

Special care should be taken that no dirt is accumulated between the working surface of fixed cores 3 and the plunger 2 which would result in vibrations and overheating of the solenoid. In the case of microsolenoid it must be assured that the alternate current coil is not charged when the mechanical part is not mounted to avoid destruction of the coil.

The electrical connections have to be perfect, especially where low currents are used (12-24 V). Oxidation of contacts between the connector and the coil can lead to intermittent malfunctions which are difficult to trace. Oxidation of contacts due to humidity or corrosive atmosphere are one of the most common causes of false alarms. Clean the contacts with appropriate spray.

Solenoid valve S and S/1



Weight 220 gr.

Normally Closed  
(N.C.) - S

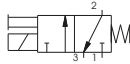

Normally Open  
(N.O.) - S/1

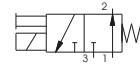

1  
AIR DISTRIBUTION

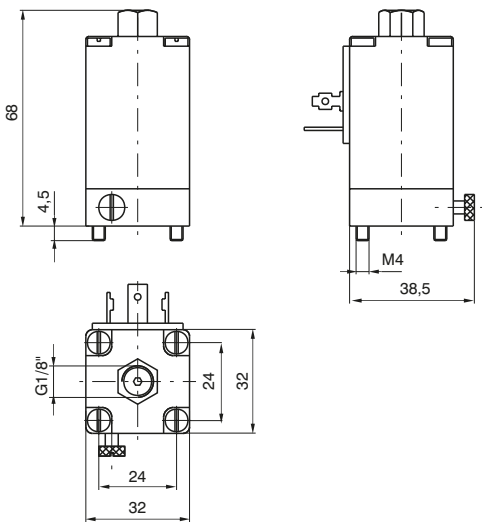

Ordering code		Available voltages Coil	
S 2 S 4 S 5 S 6	S 2/1 S 4/1 S 5/1 S 6/1	6 D.C. 12 D.C. 24 D.C. 48 D.C.	Direct current
S 16 S 17 S 19 S 20 S 21 S 22 S 23 S 24	S 16/1 S 17/1 S 19/1 S 20/1 S 21/1 S 22/1 S 23/1 S 24/1	12/50 24/50 32/50 42/50 48/50 110/50 115/50 230/50	Alternating current 50 Hz
S 36 S 37 S 38 S 39 S 40 S 41	S 36/1 S 37/1 S 38/1 S 39/1 S 40/1 S 41/1	12/60 24/60 48/60 110/60 115/60 230/60	Alternating current 60 Hz
S 56 S 57 S 58	S 56/1 S 57/1 S 58/1	24/50-60 110/50-60 230/50-60	Alternating current 50/60 Hz

Closing plate

Ordering code

300.12.00

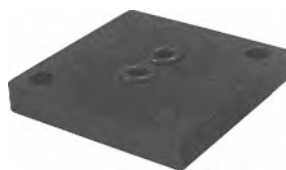

Weight 14 gr.

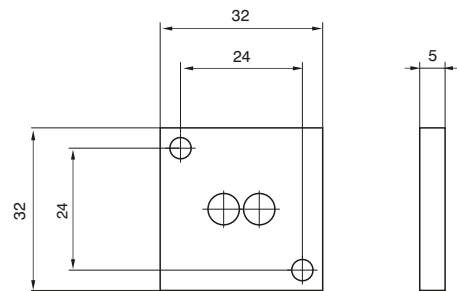

External feeding base

To be used with electrodistributeur to get a different piloting pressure from the line one.

Ordering code

300.10.05

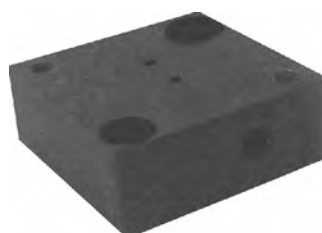

Weight 35 gr.

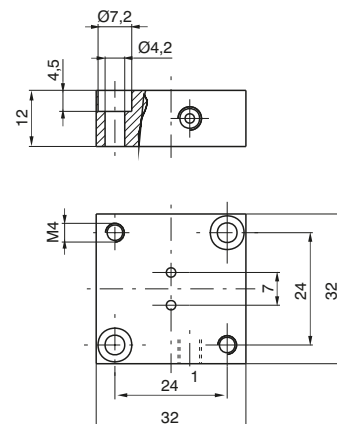



**Individual base**

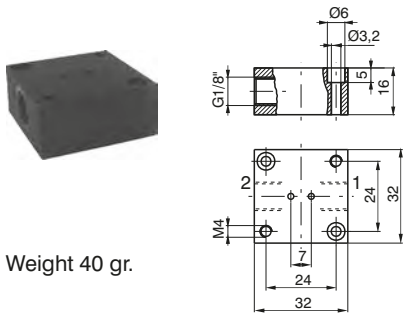

Weight 40 gr.

In line port - thread G 1/8"  
 1 = INLET PORT (N.C.)  
 2 = OUTLET PORT (N.C.)  
 With solenoid valve N.O.  
 1 = EXHAUST PORT  
 2 = OUTLET PORT

---

Ordering code

---

**300.04.00**

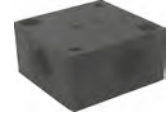

Weight 40 gr.

90° Port - thread G 1/8"  
 1 = INLET PORT (N.C.)  
 2 = OUTLET PORT (N.C.)  
 With solenoid valve N.O.  
 1 = EXHAUST PORT  
 2 = OUTLET PORT

---

Ordering code

---

**300.04.90**

**Electrical connector**

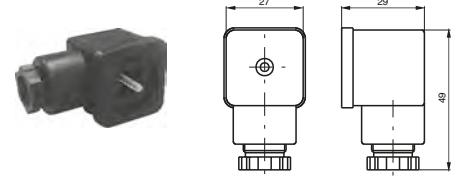

Weight 25 gr.

---

Ordering code

---

<b>300.11.00</b>	Standard
<b>300.11.0 L</b>	Led
	1 = 24 V D.C. / A.C.
	2 = 110 V 50/60 Hz
	3 = 230 V 50/60 Hz

**Modular bases for series mounting**

---

Ordering code

---

Initial base  
**300.05.00**

Intermediate base  
**300.06.00**

Last base  
**300.07.00**

Bored spacer  
**300.05.01**  
Weight 5 gr.

Solid spacer  
**300.05.02**  
Weight 6 gr.

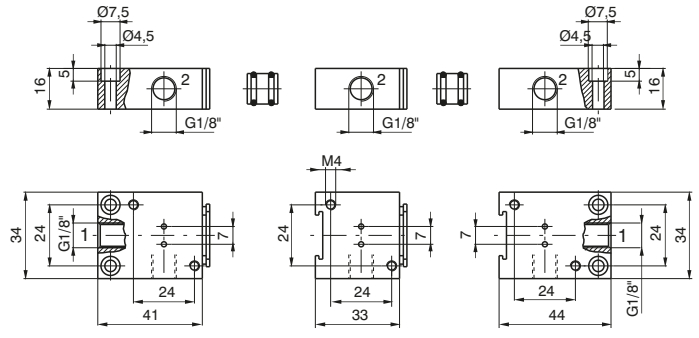

Initial base      Intermediate base      Last base



Weight 52 gr.      Weight 40 gr.      Weight 52 gr.

**Multiple integral bases for series mounting**





---

Ordering code

---

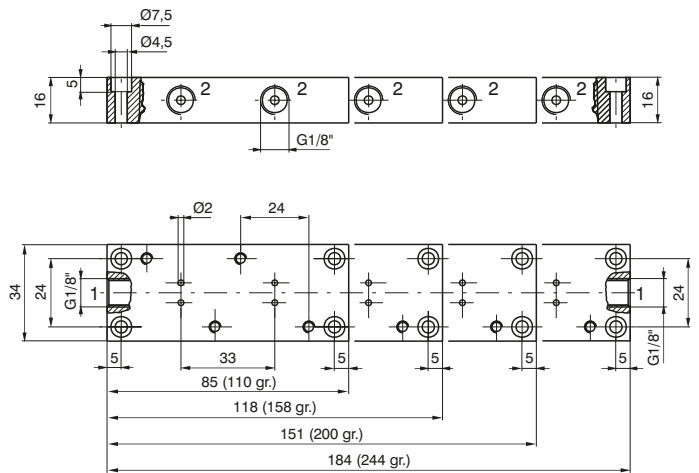
<b>300.08.02</b>	<b>2 positions</b>
<b>300.08.03</b>	<b>3 positions</b>
<b>300.08.04</b>	<b>4 positions</b>
<b>300.08.05</b>	<b>5 positions</b>



**General**

The series **us** homologated solenoid valves (valid for USA and Canada file n. E206325-VAIU2, VAIU8) are different from the standard ones for microsolenoid made with an injected RYNITE embedded copper wire (they are included in class "F" insulation).

Refer to standard versions as for as other details and accessories to be used with solenoid valves.

1  
AIR DISTRIBUTION

**Miniature solenoid valve 10mm**

Ordering code

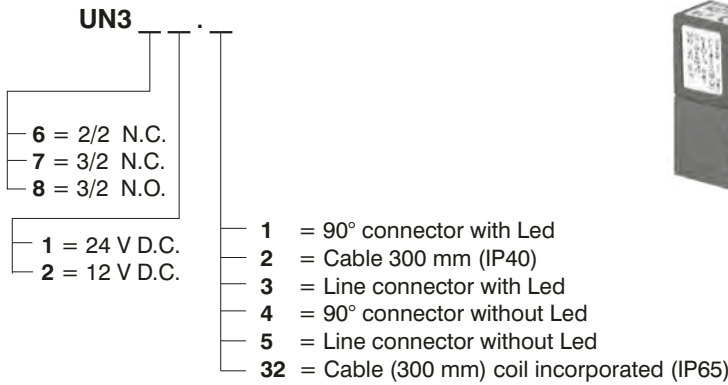

**Miniature solenoid valve 15mm**

Ordering code

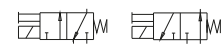
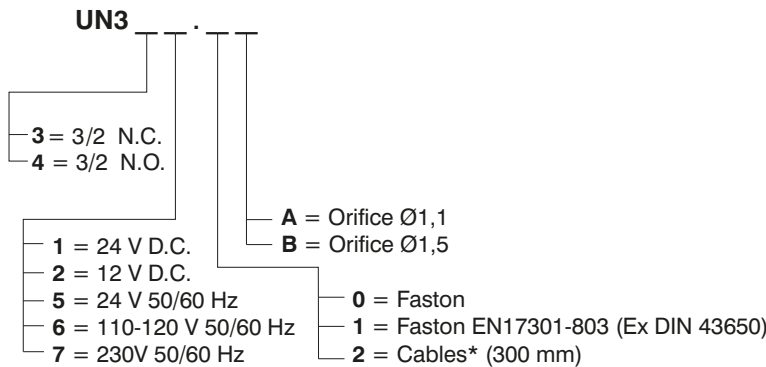

\* On request and for large quantity only (only 24 V D.C. 2,3 W)

**Miniature solenoid valve 22mm**

Ordering code

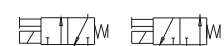
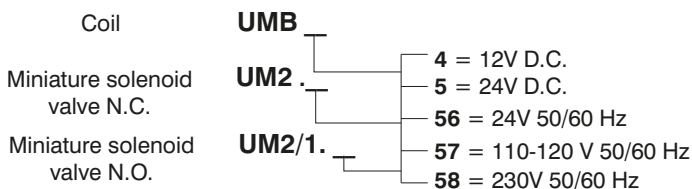

**Miniature solenoid valve 22mm for series mounting**

Ordering code

- Coil N.C. **UMB**
  - 4 = 12 V D.C.
  - 5 = 24 V D.C.
  - 56 = 24 V 50/60 Hz
  - 57 = 110-120 V 50/60 Hz
  - 58 = 230 V 50/60 Hz
  
- Coil N.O. **UMB** /1
  - 10 = 24 V D.C. 8W
  - 56 = 24 V 50/60 Hz
  - 57 = 110-120 V 50/60 Hz
  - 58 = 230 V 50/60 Hz
  
- Solenoid valve N.C. **U3** **5.M**
  - 0 = G1/8"
  - 5 = M5
  - 4 = fitting for 4mm tube
  - 4 = 12 V D.C.
  - 5 = 24 V D.C.
  - 56 = 24 V 50/60 Hz
  - 57 = 110-120 V 50/60 Hz
  - 58 = 230 V 50/60 Hz
  
- Solenoid valve N.O. **U3** **5.M** /1
  - 0 = G1/8"
  - 5 = M5
  - 4 = fitting for 4mm tube
  - 10 = 24 V D.C. 8W
  - 56 = 24 V 50/60 Hz
  - 57 = 110-120 V 50/60 Hz
  - 58 = 230 V 50/60 Hz



1  
AIR DISTRIBUTION

**Bi-stable miniature solenoid valve 22mm**

Ordering code

- Coil **UMBB5**
- Miniature solenoid valve for distributors and bases (N.C.) **UM5/B**
- Miniature solenoid valve with inseries mounting base (N.C.) **U3** **5.M5/B**
  - 0 = G1/8"
  - 5 = M5
  - 4 = fitting for 4mm tube

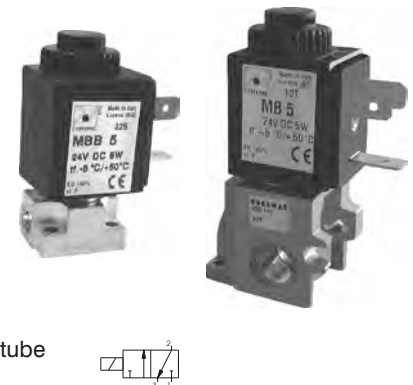

**Solenoid valve 30 mm (for mechanics M3 and M4)**

Ordering code

- UMC5** = 24 V D.C.
- UMC56** = 24 V 50/60 Hz
- UMC57** = 110 ÷ 120 V 50/60 Hz
- UMC58** = 230 V 50/60 Hz



**Solenoid valve 32 mm**

Ordering code

- Solenoid valve N.C. **US**
- Solenoid valve N.O. **US** /1
  - 4 = 12 V D.C.
  - 5 = 24 V D.C.
  - 56 = 24 V 50/60 Hz
  - 57 = 110-120 V 50/60 Hz
  - 58 = 230 V 50/60 Hz





## Series 700 - For compressed air and vacuum

### General

The large flow valves and solenoid poppet valves for compressed air and vacuum. Are manufactured for 3/2 and 2/2 versions only, either normally close and normally open. For the compressed air operation, the application is similar to the equivalent spool valves while for the vacuum operation a particular attention should be paid to the valve selected and its connection to the pump. For the electric pilot it is used a normal miniature solenoid M2 with pneumatic actuator and the special miniature solenoid M2/V with vacuum.

**The ordering code are referring to the solenoid valves with mechanics "M2" or "M2/V" assembled.**

**Coil are not included and have to be ordered separately (see Series 300).**

**Coil c**  **US homologated are available (see 300 Series).**

### Construction characteristics

	G 3/8"	G 1/2" - G 3/4"	G 1"	G 1 1/2"
Body	Aluminium	Zinc alloy	Aluminium	Aluminium
Actuators			NBR	
Bottom plates			Aluminium	
Springs			Stainless steel	
Actuators rod			Stainless steel	
Pistons			Aluminium	
Piston seals			NBR	

### Use and maintenance

These valves have a mean life of 10 to 15 million cycles under normal operating conditions. Lubrication is not required for good operation but we recommend good filtration to avoid dirty deposit causing malfunction. Please ensure that the valve is being used according with the manufacturers specification, such as air pressure and temperature. The exhaust port of the distributor has to be protected in a dusty and dirty environment. For these products, according to the construction technique and special application, is not required any maintenance with parts replacement.

When necessary it is sufficient to clean the internal parts.

When it is used the solenoid valves with internal pilot, either for air or vacuum, inlet flow rate must be equal or higher that the required consumption flow rate.

Otherwise is better choose the external pilot version.

**Pneumatic - Spring**

Coding: 779.32.11.ⓕ

Operational characteristics	
Fluid	Filtered air. No lubrication needed, if applied it shall be continuous
Max working pressure (bar)	10
Minimum piloting pressure (bar)	2,5
Temperature °C	-10 ÷ +70
Flow rate at 6 bar with Δp=1 (NI/min)	1800
Orifice size (mm)	10
Working ports size	G3/8"
Pilot ports size	G1/8"

FUNCTION	
ⓕ	1C = Normally Closed
	1A = Normally Open

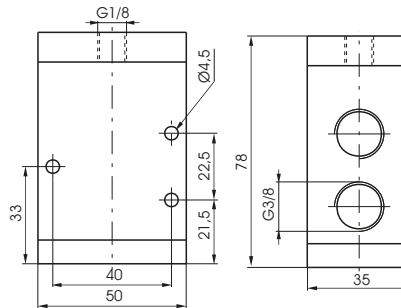

**For compressed air - N.C.**

Inlet port 1  
Outlet port 2  
Exhaust port 3

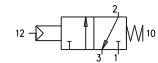

**For compressed air - N.O.**

Inlet port 3  
Outlet port 2  
Outlet port 1

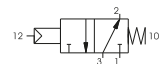

Weight 360 g  
Attention: for the Normally open version, connect the inlet port to the exhaust port No "3".

**Solenoid - Spring**

Coding: 779.32.0.ⓕ.M2

Operational characteristics	
Fluid	Filtered air. No lubrication needed, if applied it shall be continuous
Max working pressure (bar)	10
Minimum piloting pressure (bar)	2,5 (External pilot version) 3 (Internal pilot version)
Temperature °C	-10 ÷ +50
Flow rate at 6 bar with Δp=1 (NI/min)	1800
Orifice size (mm)	10
Working ports size	G3/8"
Pilot ports size	G1/8"

FUNCTION	
1AC	Internal pilot normally closed
ⓕ	1C = External pilot normally closed
1AA	Internal pilot normally open
1A	External pilot normally open

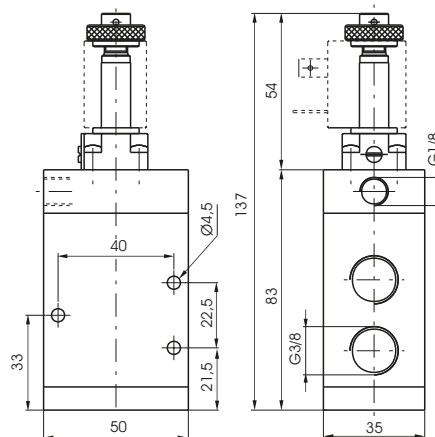

**Internal pilot - N.C.**

Inlet port 1  
Outlet port 2  
Exhaust port 3

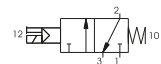

**Internal pilot - N.O.**

Inlet port 3  
Outlet port 2  
Outlet port 1

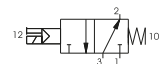

**External pilot - N.C.**

Inlet port 1  
Outlet port 2  
Exhaust port 3

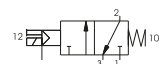

**External pilot - N.O.**

Inlet port 3  
Outlet port 2  
Outlet port 1

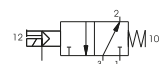

Weight 420 g



# Valves and solenoid valves poppet system Series 700 - For vacuum - G3/8"

AIR DISTRIBUTION 1

## Pneumatic - Spring

Coding: 779/V.32.11.ⓕ

Operational characteristics	
Fluid	Vacuum
Minimum piloting pressure (bar)	2
Temperature °C	-10 ÷ +70
Orifice size (mm)	10
Working ports size	G3/8"
Pilot ports size	G1/8"

FUNCTION	
ⓕ	1C = Normally Closed
	1A = Normally Open

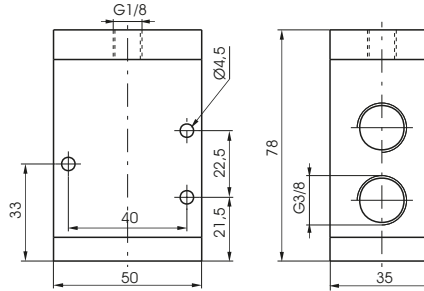

**For vacuum - N.O.**

Outlet port 1  
Outlet port 2  
Pump 3

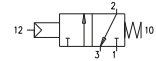

**For vacuum - N.C.**

Exhaust port 3  
Outlet port 2  
Pump 1

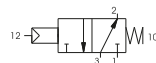

Weight 360 g

## Solenoid-Spring - Internal pilot

Coding: 779/V.32.0.ⓕ.M2/V

Operational characteristics	
Fluid	Vacuum
Temperature °C	-10 ÷ +50
Orifice size (mm)	10
Working ports size	G3/8"
Pilot ports size	G1/8"

FUNCTION	
ⓕ	1AA = Normally Open
	1AC = Normally Closed

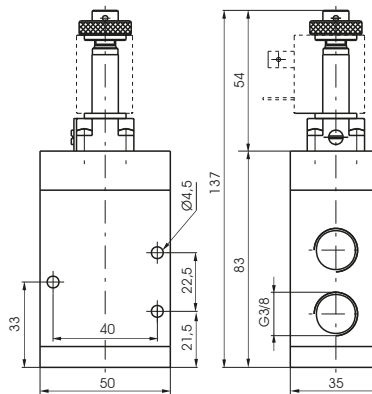

**For vacuum - N.O.**

Outlet port 1  
Outlet port 2  
Pump 3

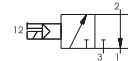

**For vacuum - N.C.**

Exhaust port 3  
Outlet port 2  
Pump 1

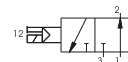

Weight 420 g

## Solenoid-Spring - External pilot

Coding: 779/V.32.0.ⓕ.M2

Operational characteristics	
Fluid	Vacuum
Minimum piloting pressure (bar)	2
Temperature °C	-10 ÷ +50
Orifice size (mm)	10
Working ports size	G3/8"
Pilot ports size	G1/8"

FUNCTION	
ⓕ	1A = Normally Open
	1C = Normally Closed

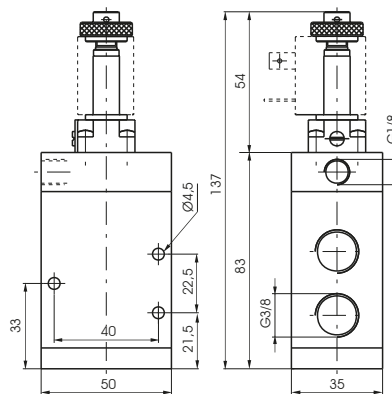

**For vacuum - N.O.**

Outlet port 1  
Outlet port 2  
Pump 3

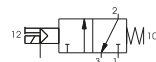

**For vacuum - N.C.**

Exhaust port 3  
Outlet port 2  
Pump 1

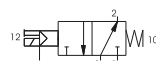

Weight 420 g

**Pneumatic - Spring**

Coding: 772.32.11.1C

Operational characteristics	
Fluid	Filtered air. No lubrication needed, if applied it shall be continuous
Max working pressure (bar)	10
Minimum piloting pressure (bar)	2,5
Temperature °C	-5 ÷ +70
Flow rate at 6 bar with Δp=1 (NI/min)	4800
Orifice size (mm)	15
Working ports size	G1/2"
Pilot ports size	G1/8"

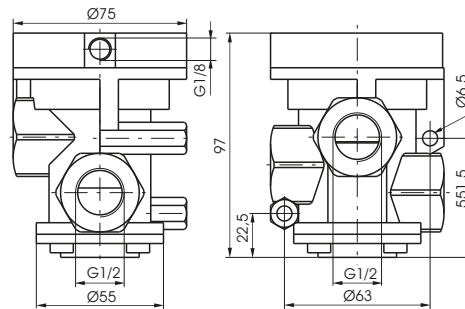

Weight 1100 g  
Normally Closed

**For compressed air - N.C.**

Inlet port 1  
Outlet port 2  
Exhaust port 3

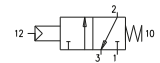

**Solenoid - Spring**

Coding: 772.32.0.Ⓜ.M2

Operational characteristics	
Fluid	Filtered air. No lubrication needed, if applied it shall be continuous
Max working pressure (bar)	10
Minimum piloting pressure (bar)	2,5 (External pilot version) 3 (Internal pilot version)
Temperature °C	-5 ÷ +50
Flow rate at 6 bar with Δp=1 (NI/min)	4800
Orifice size (mm)	15
Working ports size	G1/2"
Pilot ports size	G1/8"

FUNCTION	
Ⓜ	1AC = Internal pilot normally closed
	1C = External pilot normally closed

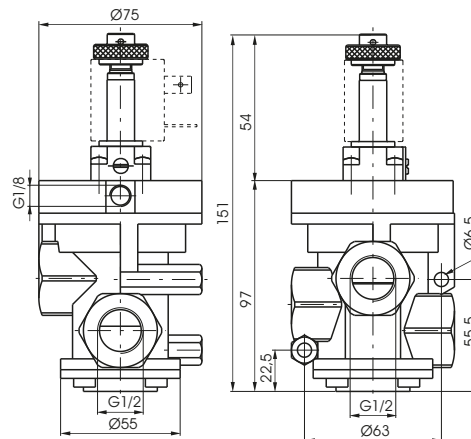

Weight 1160 g

**Internal pilot - N.C.**

Inlet port 1  
Outlet port 2  
Exhaust port 3

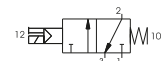

**External pilot - N.C.**

Inlet port 1  
Outlet port 2  
Exhaust port 3

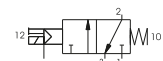



# Valves and solenoid valves poppet system

## Series 700 - For vacuum - G1/2"

AIR DISTRIBUTION 1

### Pneumatic - Spring

Coding: 772/V.32.11.F

Operational characteristics	
Fluid	Vacuum
Minimum piloting pressure (bar)	2
Temperature °C	-5 ÷ +70
Orifice size (mm)	15
Working ports size	G1/2"
Pilot ports size	G1/8"

FUNCTION	
F	1C = Normally Closed
	1A = Normally Open

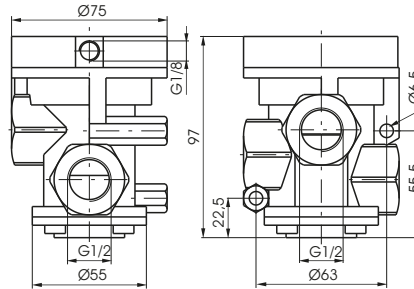

#### For vacuum - N.O.

Outlet port 1  
Outlet port 2  
Pump 3

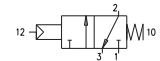

#### For vacuum - N.C.

Exhaust port 3  
Outlet port 2  
Pump 1

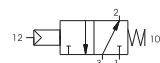

Weight 1100 g

### Solenoid-Spring - Internal pilot

Coding: 772/V.32.0.F.M2/V

Operational characteristics	
Fluid	Vacuum
Temperature °C	-5 ÷ +50
Orifice size (mm)	15
Working ports size	G1/2"
Pilot ports size	G1/8"

FUNCTION	
F	1AA = Normally Open
	1AC = Normally Closed

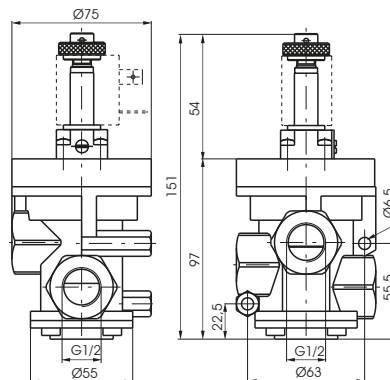

#### For vacuum - N.O.

Outlet port 1  
Outlet port 2  
Pump 3

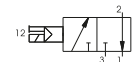

#### For vacuum - N.C.

Exhaust port 3  
Outlet port 2  
Pump 1

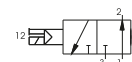

Weight 1160 g

### Solenoid-Spring - External pilot

Coding: 772/V.32.0.F.M2

Operational characteristics	
Fluid	Vacuum
Minimum piloting pressure (bar)	2
Temperature °C	-5 ÷ +50
Orifice size (mm)	15
Working ports size	G1/2"
Pilot ports size	G1/8"

FUNCTION	
F	1A = Normally Open
	1C = Normally Closed

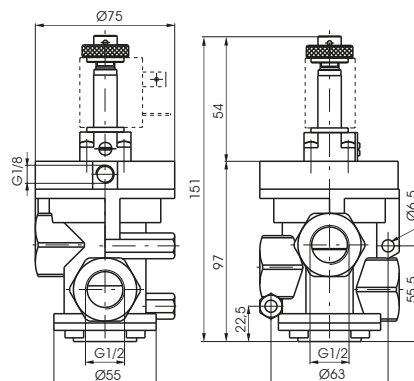

#### For vacuum - N.O.

Outlet port 1  
Outlet port 2  
Pump 3

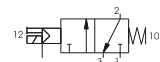

#### For vacuum - N.C.

Exhaust port 3  
Outlet port 2  
Pump 1

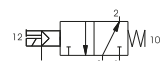

Weight 1160 g



**Pneumatic - Spring**

Coding: 773.32.11.1C

Operational characteristics	
Fluid	Filtered air. No lubrication needed, if applied it shall be continuous
Max working pressure (bar)	10
Minimum piloting pressure (bar)	2,5 bar
Temperature °C	-5 ÷ +70
Flow rate at 6 bar with Δp=1 (NI/min)	7000
Orifice size (mm)	20
Working ports size	G3/4"
Pilot ports size	G1/8"

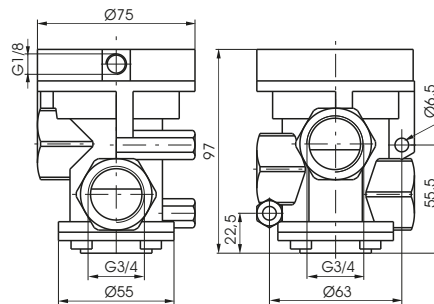

Weight 990 g  
Normally Closed

**For compressed air - N.C.**  
Inlet port 1  
Outlet port 2  
Exhaust port 3

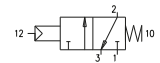

**Solenoid - Spring**

Coding: 773.32.0.Ⓜ.M2

Operational characteristics	
Fluid	Filtered air. No lubrication needed, if applied it shall be continuous
Max working pressure (bar)	10
Minimum piloting pressure (bar)	2,5 (External pilot version) 3 (Internal pilot version)
Temperature °C	-5 ÷ +50
Flow rate at 6 bar with Δp=1 (NI/min)	7000
Orifice size (mm)	20
Working ports size	G3/4"
Pilot ports size	G1/8"

FUNCTION	
Ⓜ	1AC = Internal pilot normally closed
	1C = External pilot normally closed

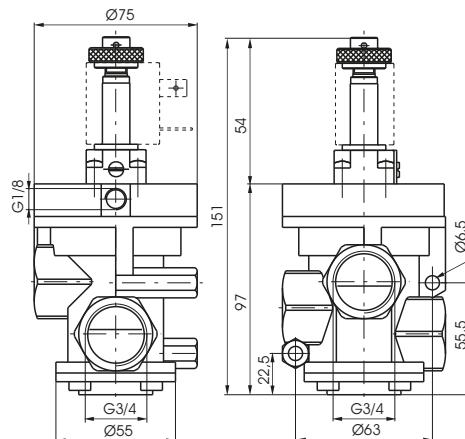

Weight 1050 g

**Internal pilot - N.C.**  
Inlet port 1  
Outlet port 2  
Exhaust port 3

**External pilot - N.C.**  
Inlet port 1  
Outlet port 2  
Exhaust port 3

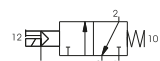
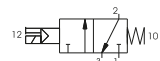



# Valves and solenoid valves poppet system Series 700 - For vacuum - G3/4"

AIR DISTRIBUTION 1

## Pneumatic - Spring

Coding: 773/V.32.11.F

Operational characteristics	
Fluid	Vacuum
Minimum piloting pressure (bar)	2
Temperature °C	-5 ÷ +70
Orifice size (mm)	20
Working ports size	G3/4"
Pilot ports size	G1/8"

FUNCTION	
F	1C = Normally Closed
	1A = Normally Open

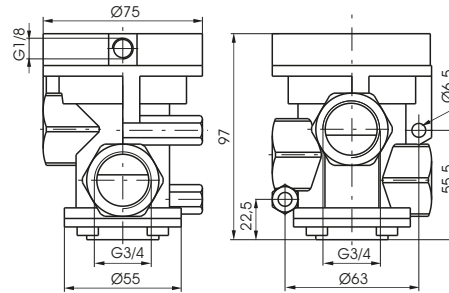

### For vacuum - N.O.

Outlet port 1  
Outlet port 2  
Pump 3

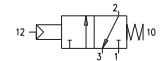

### For vacuum - N.C.

Exhaust port 3  
Outlet port 2  
Pump 1

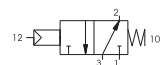

Weight 990 g

## Solenoid-Spring - Internal pilot

Coding: 773/V.32.0.F.M2/V

Operational characteristics	
Fluid	Vacuum
Temperature °C	-5 ÷ +50
Orifice size (mm)	20
Working ports size	G3/4"
Pilot ports size	G1/8"

FUNCTION	
F	1AA = Normally Open
	1AC = Normally Closed

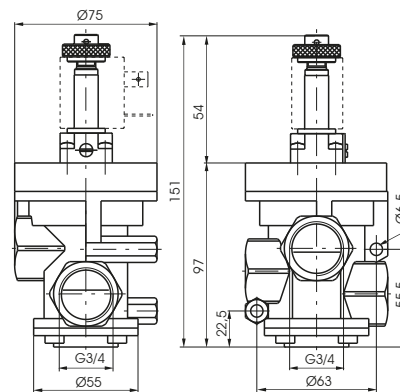

### For vacuum - N.O.

Exhaust port 3  
Outlet port 2  
Pump 1

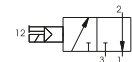

### For vacuum - N.C.

Outlet port 1  
Outlet port 2  
Pump 3

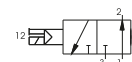

Weight 1050 g

## Solenoid-Spring - External pilot

Coding: 773/V.32.0.F.M2

Operational characteristics	
Fluid	Vacuum
Minimum piloting pressure (bar)	2
Temperature °C	-5 ÷ +50
Orifice size (mm)	20
Working ports size	G3/4"
Pilot ports size	G1/8"

FUNCTION	
F	1A = Normally Open
	1C = Normally Closed

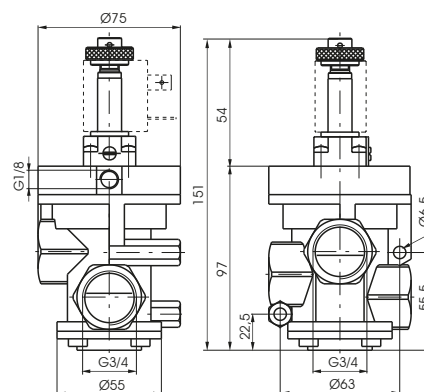

### For vacuum - N.O.

Outlet port 1  
Outlet port 2  
Pump 3

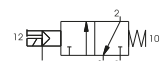

### For vacuum - N.C.

Exhaust port 3  
Outlet port 2  
Pump 1

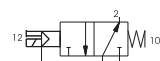

Weight 1050 g

**Pneumatic - Spring**

Coding: 771.32.11.1C

Operational characteristics	
Fluid	Filtered air. No lubrication needed, if applied it shall be continuous
Max working pressure (bar)	10
Minimum piloting pressure (bar)	2,5
Temperature °C	-5 ÷ +70
Flow rate at 6 bar with Δp=1 (NI/min)	12500
Orifice size (mm)	25
Working ports size	G1"
Pilot ports size	G1/8"

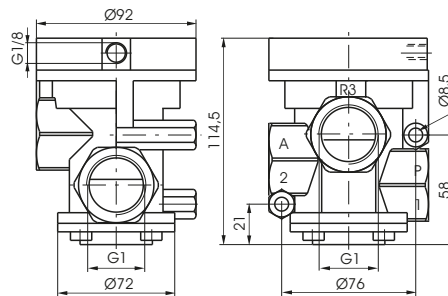

Weight 1060 g  
Normally Closed

**For compressed air - N.C.**

Inlet port 1  
Outlet port 2  
Exhaust port 3

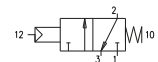

1  
AIR DISTRIBUTION

**Solenoid - Spring**

Coding: 771.32.0.Ⓜ.M2

Operational characteristics	
Fluid	Filtered air. No lubrication needed, if applied it shall be continuous
Max working pressure (bar)	10
Minimum piloting pressure (bar)	2,5 (External pilot version) 3 (Internal pilot version)
Temperature °C	-5 ÷ +50
Flow rate at 6 bar with Δp=1 (NI/min)	12500
Orifice size (mm)	25
Working ports size	G1"
Pilot ports size	G1/8"

FUNCTION	
Ⓜ	1AC = Internal pilot normally closed
	1C = External pilot normally closed

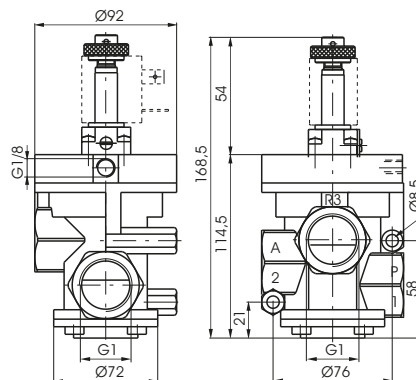

Weight 1120 g

**Internal pilot - N.C.**

Inlet port 1  
Outlet port 2  
Exhaust port 3

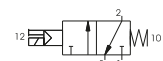

**External pilot - N.C.**

Inlet port 1  
Outlet port 2  
Exhaust port 3

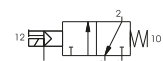



# Valves and solenoid valves poppet system Series 700 - For vacuum - G1"

AIR DISTRIBUTION 1

## Pneumatic - Spring

Coding: 771/V.32.11.Ⓡ

Operational characteristics	
Fluid	Vacuum
Minimum piloting pressure (bar)	2
Temperature °C	-5 ÷ +70
Orifice size (mm)	25
Working ports size	G1"
Pilot ports size	G1/8"

FUNCTION	
Ⓡ	1C = Normally Closed
	1A = Normally Open

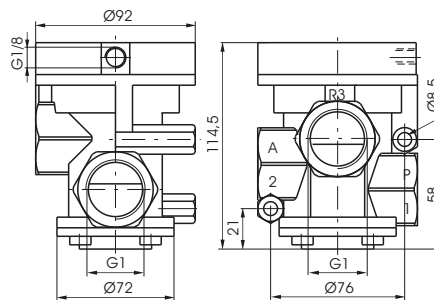

Weight 1060 g

**For vacuum - N.O.**  
Outlet port 1  
Outlet port 2  
Pump 3

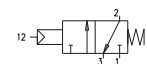

**For vacuum - N.C.**  
Exhaust port 3  
Outlet port 2  
Pump 1

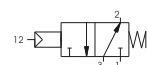

## Solenoid-Spring - Internal pilot

Coding: 771/V.32.0.Ⓡ.M2/V

Operational characteristics	
Fluid	Vacuum
Temperature °C	-5 ÷ +50
Orifice size (mm)	25
Working ports size	G1"
Pilot ports size	G1/8"

FUNCTION	
Ⓡ	1AA = Normally Open
	1AC = Normally Closed

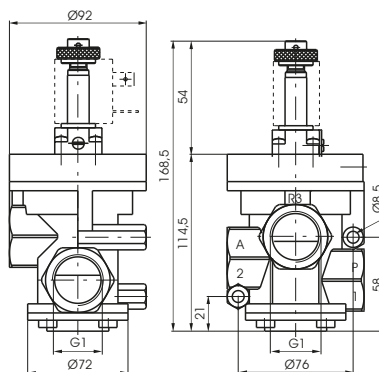

Weight 1120 g

**For vacuum - N.O.**  
Exhaust port 3  
Outlet port 2  
Pump 1

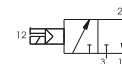

**For vacuum - N.C.**  
Outlet port 1  
Outlet port 2  
Pump 3

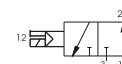

## Solenoid-Spring - External pilot

Coding: 771/V.32.0.Ⓡ.M2

Operational characteristics	
Fluid	Vacuum
Minimum piloting pressure (bar)	2
Temperature °C	-5 ÷ +50
Orifice size (mm)	25
Working ports size	G1"
Pilot ports size	G1/8"

FUNCTION	
Ⓡ	1A = Normally Open
	1C = Normally Closed

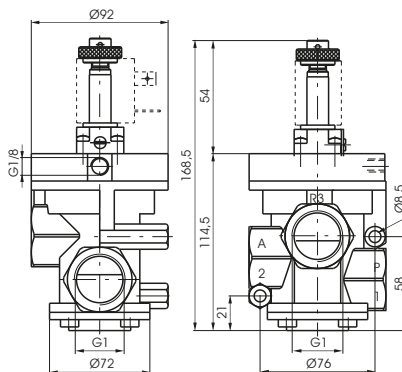

Weight 1120 g

**For vacuum - N.O.**  
Outlet port 1  
Outlet port 2  
Pump 3

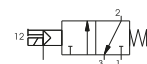

**For vacuum - N.C.**  
Exhaust port 3  
Outlet port 2  
Pump 1

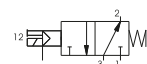

**Pneumatic - Spring**

Coding: 776.22.11.1C

Operational characteristics	
Fluid	Filtered air. No lubrication needed, if applied it shall be continuous
Max working pressure (bar)	10
Minimum piloting pressure (bar)	2,5
Temperature °C	-5 ÷ +70
Flow rate at 6 bar with Δp=1 (NI/min)	33500
Orifice size (mm)	38
Working ports size	G1 1/2"
Pilot ports size	G1/8"



Weight 3950 g  
Normally Closed

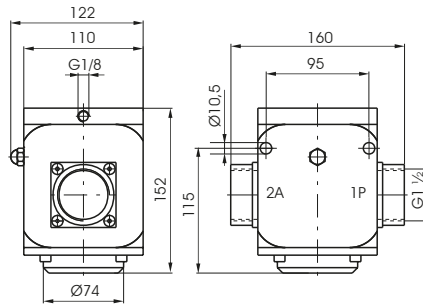

For compressed air - N.C.  
Inlet port 1  
Outlet port 2

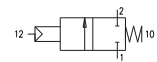

**Solenoid - Spring**

Coding: 776.22.0.F.S

Operational characteristics	
Fluid	Filtered air. No lubrication needed, if applied it shall be continuous
Max working pressure (bar)	10
Minimum piloting pressure (bar)	2,5 (External pilot version) 3 (Internal pilot version)
Temperature °C	-5 ÷ +50
Flow rate at 6 bar with Δp=1 (NI/min)	33500
Orifice size (mm)	38
Working ports size	G1 1/2"
Pilot ports size	G1/8"

FUNCTION	
F	1AC = Internal pilot normally closed
	1C = External pilot normally closed
SOLENOID CODE	
S	SEE SOLENOID VALVES "S" TYPE, SERIES 300



Weight 4450 g

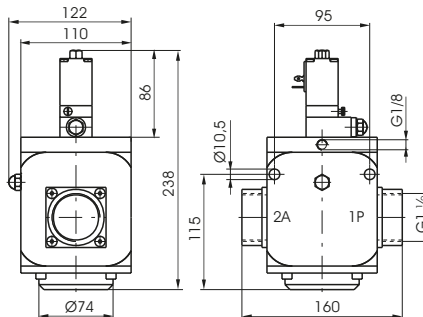

Internal pilot - N.C.  
Inlet port 1  
Outlet port 2

External pilot - N.C.  
Inlet port 1  
Outlet port 2

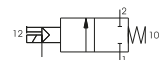
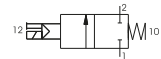

**Pneumatic - Spring**

Coding: 776.32.11.1C

Operational characteristics	
Fluid	Filtered air. No lubrication needed, if applied it shall be continuous
Max working pressure (bar)	10
Minimum piloting pressure (bar)	2,5
Temperature °C	-5 ÷ +70
Flow rate at 6 bar with Δp=1 (NI/min)	33500
Orifice size (mm)	38
Working ports size	G1 1/2"
Pilot ports size	G1/8"



Weight 3900 g  
Normally Closed

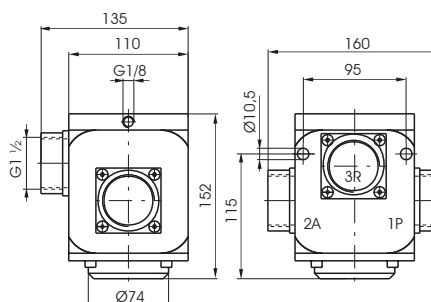

For compressed air - N.C.  
Inlet port 1  
Outlet port 2  
Exhaust port 3

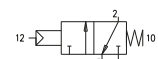



Solenoid - Spring

Coding: 776.32.0.F.S

Operational characteristics

Fluid	Filtered air. No lubrication needed, if applied it shall be continuous
Max working pressure (bar)	10
Minimum piloting pressure (bar)	2,5 (External pilot version) 3 (Internal pilo version)
Temperature °C	-5 ÷ +50
Flow rate at 6 bar with Δp=1 (NI/min)	33500
Orifice size (mm)	38
Working ports size	G1 1/2"
Pilot ports size	G1/8"

FUNCTION	
F	1AC = Internal pilot normally closed
	1C = External pilot normally closed
SOLENOID CODE	
S	SEE SOLENOID VALVES "S" TYPE, SERIES 300

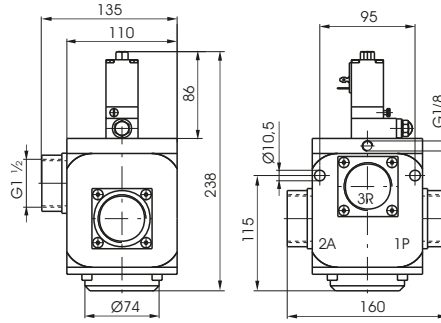

Internal pilot - N.C.

Inlet port 1  
Outlet port 2  
Exhaust port 3

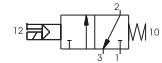

External pilot - N.C.

Inlet port 1  
Outlet port 2  
Exhaust port 3

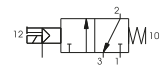

Weight 4450 g

1 AIR DISTRIBUTION

**Pneumatic - Spring**

Coding: 776/V.22.11.1C

Operational characteristics	
Fluid	Vacuum
Minimum piloting pressure (bar)	2
Temperature °C	-5 ÷ +70
Orifice size (mm)	38
Working ports size	G1 1/2"
Pilot ports size	G1/8"



Weight 3950 g  
Normally Closed

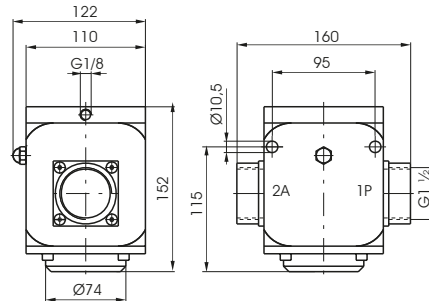

For vacuum - N.C.  
Outlet port 2  
Pump 1

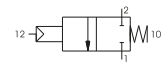

**Solenoid - Spring**

Coding: 776/V.22.0.1C.S

Operational characteristics	
Fluid	Vacuum
Minimum piloting pressure (bar)	2
Temperature °C	-5 ÷ +50
Orifice size (mm)	38
Working ports size	G1 1/2"
Pilot ports size	G1/8"

SOLENOID CODE  
S SEE SOLENOID VALVES "S" TYPE,  
SERIES 300



Weight 4450 g  
External pilot normally closed

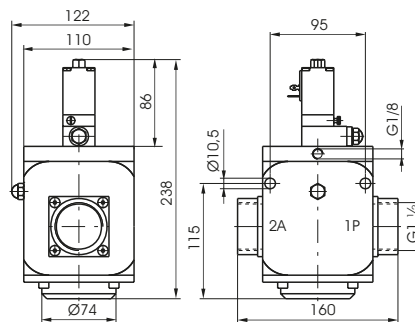

For vacuum - N.C.  
Outlet port 2  
Pump 1

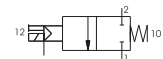

**Pneumatic - Spring**

Coding: 776/V.32.11.F

Operational characteristics	
Fluid	Vacuum
Minimum piloting pressure (bar)	2
Temperature °C	-5 ÷ +70
Orifice size (mm)	38
Working ports size	G1 1/2"
Pilot ports size	G1/8"

FUNCTION  
F 1C = Normally Closed  
1A = Normally Open



Weight 3900 g

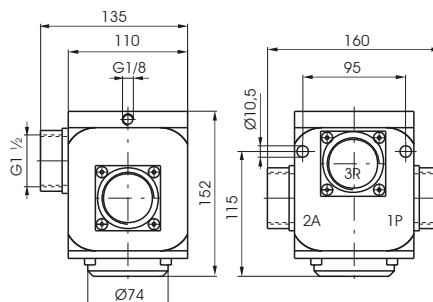

For vacuum - N.O.  
Outlet port 1  
Outlet port 2  
Pump 3

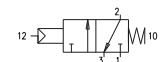

For vacuum - N.C.  
Exhaust port 3  
Outlet port 2  
Pump 1

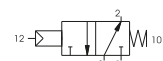



Solenoid - Spring

Coding: 776/V.32.0.F.S

Operational characteristics

Fluid	Vacuum
Minimum piloting pressure (bar)	2
Temperature °C	-5 ÷ +50
Orifice size (mm)	38
Working ports size	G1 1/2"
Pilot ports size	G1/8"

FUNCTION	
F	1C = External pilot normally closed
	1A = External pilot normally open
SOLENOID CODE	
S	SEE SOLENOID VALVES "S" TYPE, SERIES 300

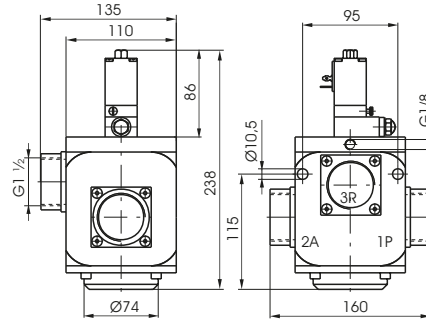

For vacuum - N.O.

Outlet port 1  
Outlet port 2  
Pump 3

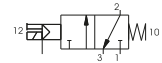

For vacuum - N.C.

Exhaust port 3  
Outlet port 2  
Pump 1

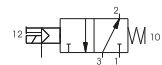

Weight 4500 g

1 AIR DISTRIBUTION





## Series N776 - For compressed air and vacuum - G1 1/2"

### General

The N776 G1.1/2" series of valves and solenoid operated poppet valves is the result of the technical evolution of the 776 series. A rolling diaphragm construction has replaced the previously used piston design ensure lower frictions and longer life. Connection 3 is isolated via a dedicated seal which allow to have the N.O. version as well as the self feed for vacuum which was not available on the 776 series.

The pilot valves are the M3R (CNOMO Stile) with bistable manual override.

**Coils are not included and have to be ordered separately (see 300 series, 22mm MB coils and 30mm CNOMO MC coils).**

**Coils c**  **US homologated are also available. (See series 300).**

### Construction characteristics

Springs	Stainless steel
Pistons	Aluminium (for Air) - Acetylic resin (for Vacuum)
Pin guide	Stainless steel
Diaphragm	NBR oil resistant rubber
Body, operator and end cover	Die-cast aluminium
Seals and poppets	NBR

### Use and maintenance

These valves have a mean life of 10 to 15 million cycles under normal operating conditions.

Lubrication is not required for good operation but we recommend good filtration to avoid dirty deposit causing malfunction.

Please ensure that the valve is being used according with the manufacturers specification, such as air pressure and temperature.

The exhaust port of the distributor has to be protected in a dusty and dirty environment.

For these products, according to the construction technique and special application, is not required any maintenance with parts replacement.

When necessary it is sufficient to clean the internal parts.

When it is used the solenoid valves with internal pilot, either for air or vacuum, inlet flow rate must be equal or higher that the required consumption flow rate.

Otherwise is better choose the external pilot version.

### Mininum working pressure diagram

for external pilot versions N.C. & N.O.

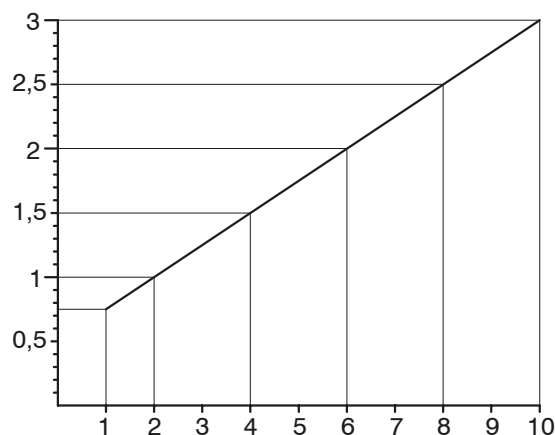



# Valves and solenoid valves poppet system Series N776 - For compressed air - G1 1/2"

AIR DISTRIBUTION

## Pneumatic - Spring

Coding: N776.22.11.1C

### Operational characteristics

Fluid	Filtered air. No lubrication needed, if applied it shall be continuous
Max working pressure (bar)	10
Minimum piloting pressure (bar)	See diagram at general page
Temperature °C	-5 ÷ +70
Flow rate at 6 bar with Δp=1 (NI/min)	33500
Orifice size (mm)	38
Working ports size	G 1 1/2"
Pilot ports size	G1/8"

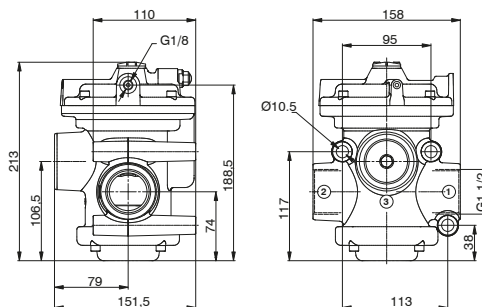

Weight 3560 g  
Normally Closed

For compressed air - N.C.  
Inlet port 1  
Outlet port 2

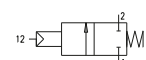

## Solenoid - Spring

Coding: N776.22.0.F.M3R

### Operational characteristics

Fluid	Filtered air. No lubrication needed, if applied it shall be continuous
Max working pressure (bar)	10
Minimum piloting pressure (bar)	See diagram at general page (External pilot version) 3,5 (Internal pilot version)
Temperature °C	-5 ÷ +50
Flow rate at 6 bar with Δp=1 (NI/min)	33500
Orifice size (mm)	38
Working ports size	G 1 1/2"
Pilot ports size	G1/8"

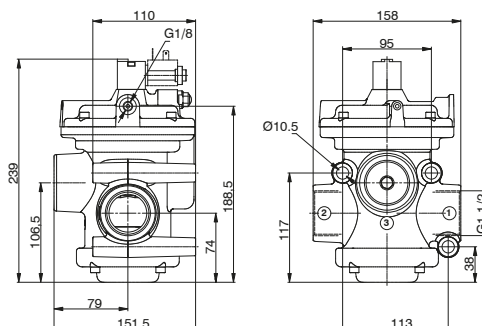

Weight 3620 g

Internal pilot - N.C.  
Inlet port 1  
Outlet port 2

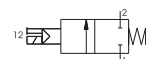

External pilot - N.C.  
Inlet port 1  
Outlet port 2

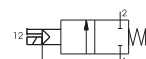

## Pneumatic - Spring

Coding: N776.32.11.1

### Operational characteristics

Fluid	Filtered air. No lubrication needed, if applied it shall be continuous
Max working pressure (bar)	10
Minimum piloting pressure (bar)	See diagram at general page
Temperature °C	-5 ÷ +70
Flow rate at 6 bar with Δp=1 (NI/min)	33500
Orifice size (mm)	38
Working ports size	G 1 1/2"
Pilot ports size	G1/8"

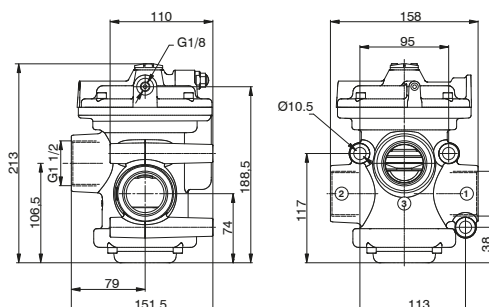

Weight 3550 g  
Normally closed/Normally open

For compressed air - N.C.  
Inlet port 1  
Outlet port 2  
Exhaust port 3

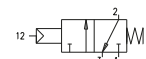

For compressed air - N.O.  
Inlet port 3  
Outlet port 2  
Outlet port 1

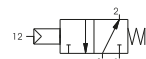

**Solenoid - Spring**

Coding: N776.32.0.Ⓜ.M3R

Operational characteristics	
Fluid	Filtered air. No lubrication needed, if applied it shall be continuous
Max working pressure (bar)	10
Minimum piloting pressure (bar)	See diagram at general page (External pilot version) 3.5 (Internal pilot version)
Temperature °C	-5 ÷ +50
Flow rate at 6 bar with Δp=1 (NI/min)	33500
Orifice size (mm)	38
Working ports size	G 1 1/2"
Pilot ports size	G1/8"

FUNCTION	
1AC	= Internal pilot normally closed
Ⓜ 1AA	= Internal pilot normally open
1	= External pilot Normally closed- Normally open

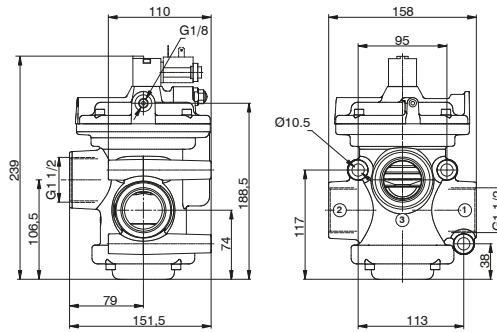

**Internal pilot - N.C.**  
Inlet port 1  
Outlet port 2  
Exhaust port 3

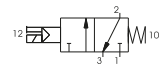

**Internal pilot - N.O.**  
Inlet port 3  
Outlet port 2  
Outlet port 1

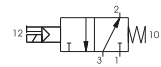

**External pilot for compressed air - N.C. - N.O.**  
Inlet port 1 (N.C.) or 3 (N.O.)  
Outlet 2 (N.C. & N.O.)  
Exhaust 3 (N.C.) or 1 (N.O.)

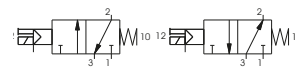

Weight 3610 g

1  
AIR DISTRIBUTION



# Valves and solenoid valves poppet system Series N776 - For vacuum - G1 1/2"

1 AIR DISTRIBUTION

## Pneumatic - Spring

Coding: N776/V.22.11.1C

Operational characteristics	
Fluid	Vacuum
Minimum piloting pressure (bar)	2
Temperature °C	-5 ÷ +70
Orifice size (mm)	38
Working ports size	G 1 1/2"
Pilot ports size	G1/8"

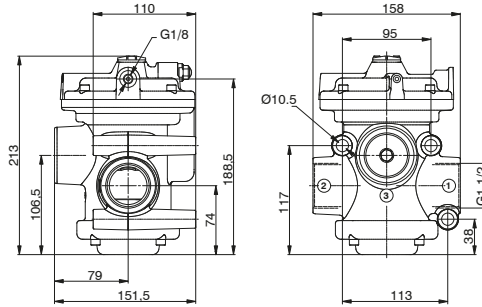

Weight 3178 g  
Normally Closed

**For vacuum - N.C.**  
Outlet port 2  
Pump 1

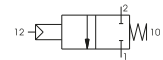

## Solenoid - Spring

Coding: N776/V.22.0.F.M3R

Operational characteristics	
Fluid	Vacuum
Minimum piloting pressure (bar)	2 (External pilot version)
Temperature °C	-5 ÷ +50
Orifice size (mm)	38
Working ports size	G 1 1/2"
Pilot ports size	G1/8"

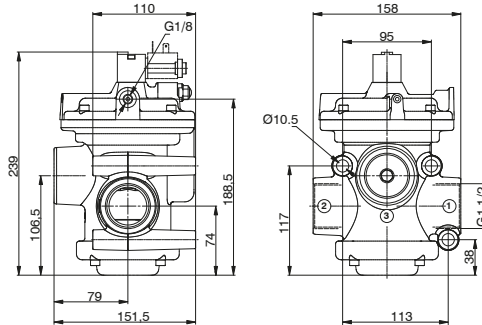

Weight 3238 g

**Internal pilot for vacuum - N.C.**  
Outlet port 2  
Pump 1

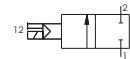

**External pilot for vacuum - N.C.**  
Outlet port 2  
Pump 1

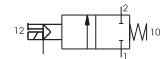

## Pneumatic - Spring

Coding: N776/V.32.11.1

Operational characteristics	
Fluid	Vacuum
Minimum piloting pressure (bar)	2
Temperature °C	-5 ÷ +70
Orifice size (mm)	38
Working ports size	G 1 1/2"
Pilot ports size	G1/8"

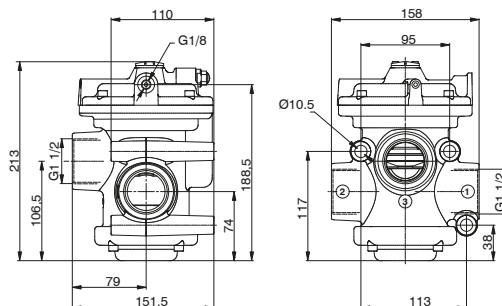

Weight 3168 g  
Normally closed/Normally open

**For vacuum - N.O.**  
Outlet port 1  
Outlet port 2  
Pump 3

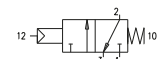

**For vacuum - N.C.**  
Exhaust port 3  
Outlet port 2  
Pump 1

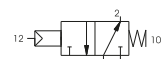

**Solenoid - Spring**

Coding: N776/V.32.0.Ⓢ.M3R

Operational characteristics	
Fluid	Vacuum
Minimum piloting pressure (bar)	2 (External pilot version)
Temperature °C	-5 ÷ +50
Orifice size (mm)	38
Working ports size	G 1 1/2"
Pilot ports size	G1/8"

FUNCTION	
1AC	= Internal pilot normally closed
Ⓢ 1AA	= Internal pilot normally open
1	= External pilot Normally closed- Normally open

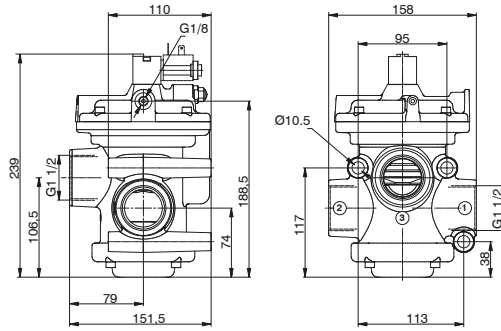

Weight 3228 g

**Internal pilot for vacuum - N.C.**

Exhaust port 3  
Outlet port 2  
Pump 1

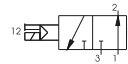

**Internal pilot for vacuum - N.O.**

Outlet port 1  
Outlet port 2  
Pump 3

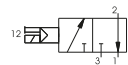

**External pilot for vacuum - N.C. - N.O.**

Exhaust 3 (N.C.) or (N.O.)  
Outlet 2 (N.C. & N.O.)  
Pump 1 (N.C.) & 3 (N.O.)



1  
AIR DISTRIBUTION



**Series T772-773 - for compressed air and vacuum in technopolymer - G1/2" & G3/4"**

**General**

The range of G1/2" and G3/4" pilot and solenoid operated poppet valves are manufactured with high impact resistant thermoplastic. The use of this material results in a versatile, lightweight and economical valve. The traditional piston lip seal has been replaced with a rolling diaphragm, thereby eliminating frictional wear and tear to this seal. The valves (with the exception of certain vacuum models) also features a seal, which separates port 3 from the piston head. The inclusion of this seal has enhanced the valve's performance and allows the valve to be used as normally open (a configuration not possible in the Zama series). Solenoid operated valves (both internal and external pilot versions) are fitted with a quick exhaust unit, which reduces the return stroke operating time by 60%.

The bulk of the valves in this series use the MP type operator, the exception being internally piloted vacuum models, which use the MV operator. These operators differ from the M2 type in that they have self-tapping mounting screws for use in plastics.

**The ordering code are referring to the solenoid valves with mechanics "MP" or "MV" assembled.**  
**Coils are not included and have to be ordered separately (series 300, Section 1, General Catalogue), with the exception of the bistable versions which already include 24V DC Coils (N331.0A).**  
**Coils c**  **US homologated are also available. (See series 300).**

**Construction characteristics**

Body, operator and end cover	High impact resistant thermoplastic
Seals and poppets	NBR
Diaphragm	Oil resistant rubber (NBR)
Springs	AISI 302 stainless steel
Piston and shaft	Acetal resin

**Use and maintenance**

These valves have a mean life of 10 to 15 million cycles under normal operating conditions. Lubrication is not required for good operation but we recommend good filtration to avoid dirty deposit causing malfunction. Please ensure that the valve is being used according with the manufacturers specification, such as air pressure and temperature. The exhaust port of the distributor has to be protected in a dusty and dirty environment. For these products, according to the construction technique and special application, is not required any maintenance with parts replacement. When necessary it is sufficient to clean the internal parts. When it is used the solenoid valves with internal pilot, either for air or vacuum, inlet flow rate must be equal or higher that the required consumption flow rate. Otherwise is better choose the external pilot version.

**MINIMUM PILOTING PRESSURE DIAGRAM (Valves for compressed air)  
 PNEUMATIC/SPRING AND EXTERNAL SOLENOID PILOT VERSION**

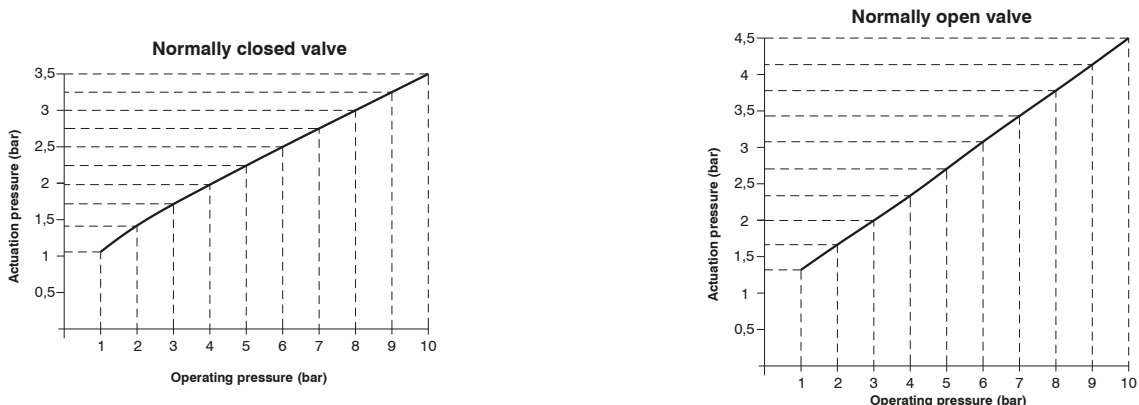

AIR DISTRIBUTION 1

**Pneumatic - Spring**

Coding: T772.32.11.1

Operational characteristics	
Fluid	Filtered and lubricated air or non
Max working pressure (bar)	10
Minimum piloting pressure (bar)	See diagram at general page
Temperature °C	-5 ... +50
Flow rate at 6 bar with Δp=1 (NI/min)	4100
Orifice size (mm)	15
Working ports size	G1/2"
Pilot ports size	G1/8"
Compressed air, purity class according to ISO 8573-1:2010	7:4:4

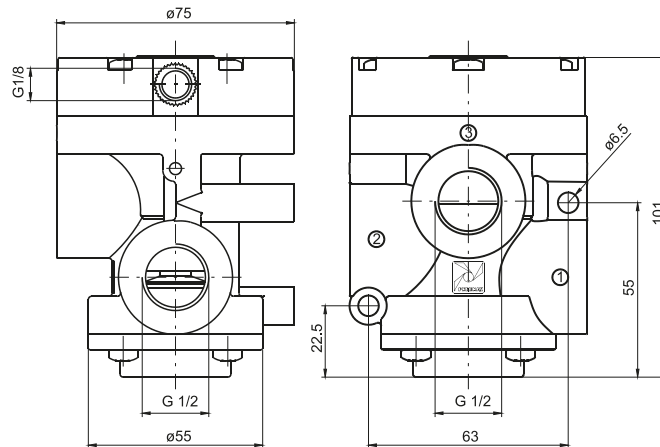

Weight 350 g

**For compressed air-N.C.**  
Inlet port 1  
Outlet port 2  
Exhaust port 3

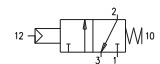

**For compressed air-N.O.**  
Inlet port 3  
Outlet port 2  
Outlet port 1

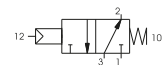

1  
AIR DISTRIBUTION

**Solenoid-Spring-Internal pilot**

Coding: T772.32.0.Ⓜ.MP

Operational characteristics	
Fluid	Filtered and lubricated air or non
Max working pressure (bar)	10
Minimum piloting pressure (bar)	2,5
Temperature °C	-5 ... +50
Flow rate at 6 bar with Δp=1 (NI/min)	4100
Orifice size (mm)	15
Working ports size	G1/2"
Pilot ports size	G1/8"
Compressed air, purity class according to ISO 8573-1:2010	7:4:4

FUNCTION	
Ⓜ	1AA = Normally Open
Ⓜ	1AC = Normally Closed

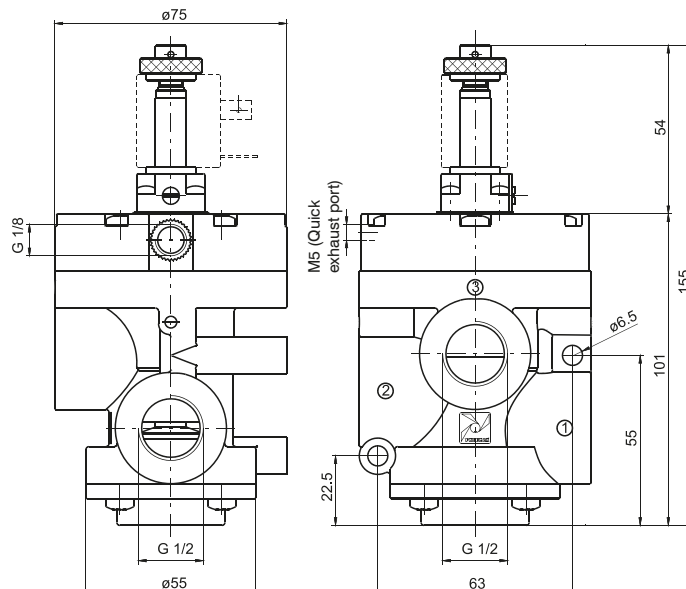

Weight 390 g

**For compressed air-N.C.**  
Inlet port 1  
Outlet port 2  
Exhaust port 3

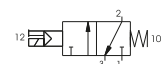

**For compressed air-N.O.**  
Inlet port 3  
Outlet port 2  
Outlet port 1

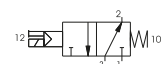



**Solenoid-Spring-External pilot**

Coding: T772.32.0.1.MP

Operational characteristics	
Fluid	Filtered and lubricated air or non
Max working pressure (bar)	10
Minimum piloting pressure (bar)	See diagram at general page
Temperature °C	-5 ... +50
Flow rate at 6 bar with $\Delta p=1$ (NI/min)	4100
Orifice size (mm)	15
Working ports size	G1/2"
Pilot ports size	G1/8"
Compressed air, purity class according to ISO 8573-1:2010	7:4:4

AIR DISTRIBUTION



Weight 390 g

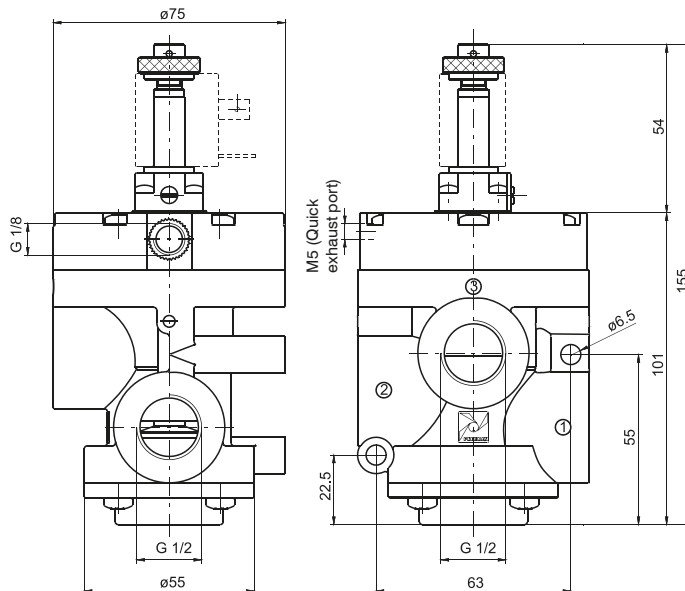

**For compressed air-N.C.**

- Inlet port 1
- Outlet port 2
- Exhaust port 3

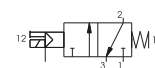

**For compressed air-N.O.**

- Inlet port 3
- Outlet port 2
- Outlet port 1

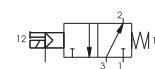

**Solenoid-Spring - Internal pilot with quick exhaust**

Coding: T772S.32.0.1.MP

Operational characteristics	
Fluid	Filtered and lubricated air or non
Max working pressure (bar)	10
Minimum piloting pressure (bar)	2,5
Temperature °C	-5 ... +50
Flow rate at 6 bar with $\Delta p=1$ (NI/min)	4100
Orifice size (mm)	15
Working ports size	G1/2"
Pilot ports size	G1/8"
Compressed air, purity class according to ISO 8573-1:2010	7:4:4

FUNCTION	
<b>F</b>	<b>1AA = Normally Open</b>
	<b>1AC = Normally Closed</b>



Weight 390 g

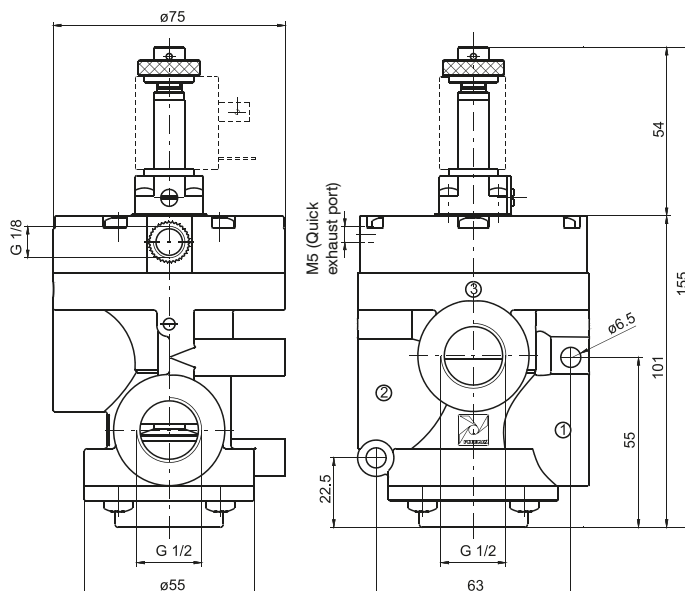

**For compressed air-N.C.**

- Inlet port 1
- Outlet port 2
- Exhaust port 3

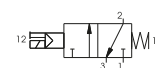

**For compressed air-N.O.**

- Inlet port 3
- Outlet port 2
- Outlet port 1

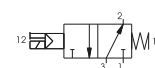



**Solenoid-Spring - External pilot with quick exhaust**

Coding: T772S.32.0.1.MP

Operational characteristics	
Fluid	Filtered and lubricated air or non
Max working pressure (bar)	10
Minimum piloting pressure (bar)	See diagram at general page
Temperature °C	-5 ... +50
Flow rate at 6 bar with $\Delta p=1$ (NI/min)	4100
Orifice size (mm)	15
Working ports size	G1/2"
Pilot ports size	G1/8"
Compressed air, purity class according to ISO 8573-1:2010	7:4:4



Weight 390 g

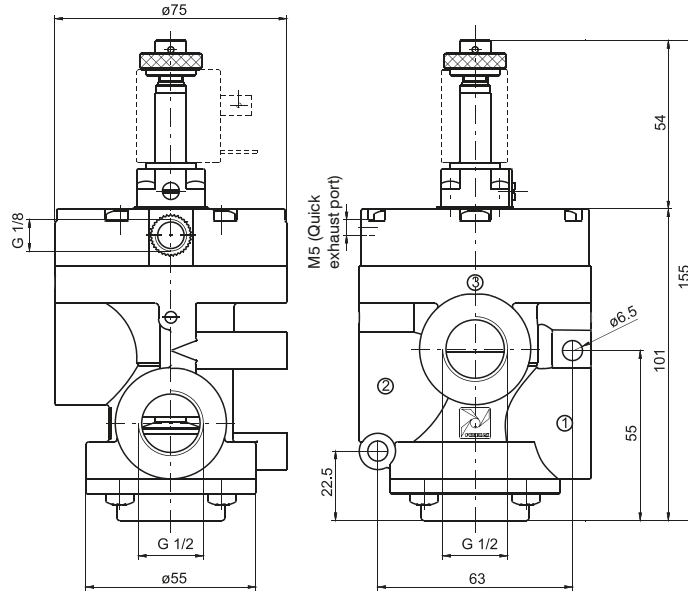

**For compressed air-N.C.**  
Inlet port 1  
Outlet port 2  
Exhaust port 3

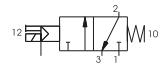

**For compressed air-N.O.**  
Inlet port 3  
Outlet port 2  
Outlet port 1

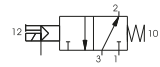

1  
AIR DISTRIBUTION



**Pneumatic - Spring**

Coding: T772/V.32.11.1

Operational characteristics	
Fluid	Vacuum
Minimum piloting pressure (bar)	2,5
Temperature °C	-5 ... +50
Orifice size (mm)	15
Working ports size	G1/2"
Pilot ports size	G1/8"

AIR DISTRIBUTION

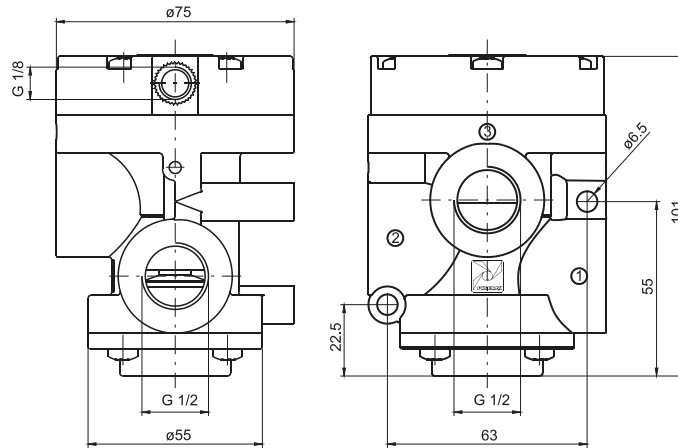

Weight 350 g

**For vacuum-N.C.**  
Exhaust port 3  
Outlet port 2  
Pump 1

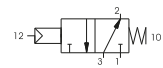

**For vacuum-N.O.**  
Outlet port 1  
Outlet port 2  
Pump 3

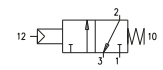

**Solenoid-Spring-Internal pilot**

Coding: T772/V.32.0.Ⓜ.MV

Operational characteristics	
Fluid	Vacuum
Temperature °C	-5 ... +50
Orifice size (mm)	15
Working ports size	G1/2"
Pilot ports size	G1/8"

FUNCTION	
Ⓜ	1AA = Normally Open
Ⓜ	1AC = Normally Closed

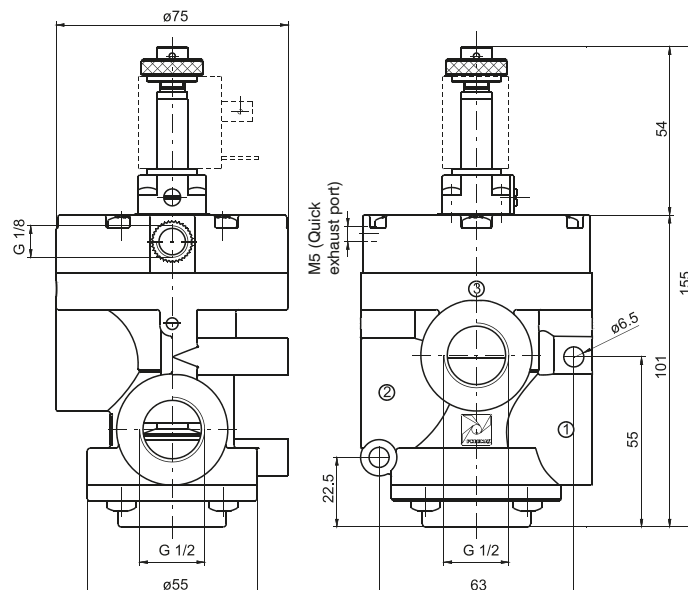

Weight 390 g

**For vacuum-N.O.**  
Exhaust port 3  
Outlet port 2  
Pump 1

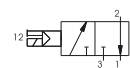

**For vacuum-N.C.**  
Outlet port 1  
Outlet port 2  
Pump 3

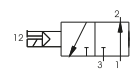

**Solenoid-Spring-External pilot**

Coding: T772/V.32.0.1.MP

Operational characteristics	
Fluid	Vacuum
Minimum piloting pressure (bar)	2,5
Temperature °C	-5 ... +50
Orifice size (mm)	15
Working ports size	G1/2"
Pilot ports size	G1/8"



Weight 390 g

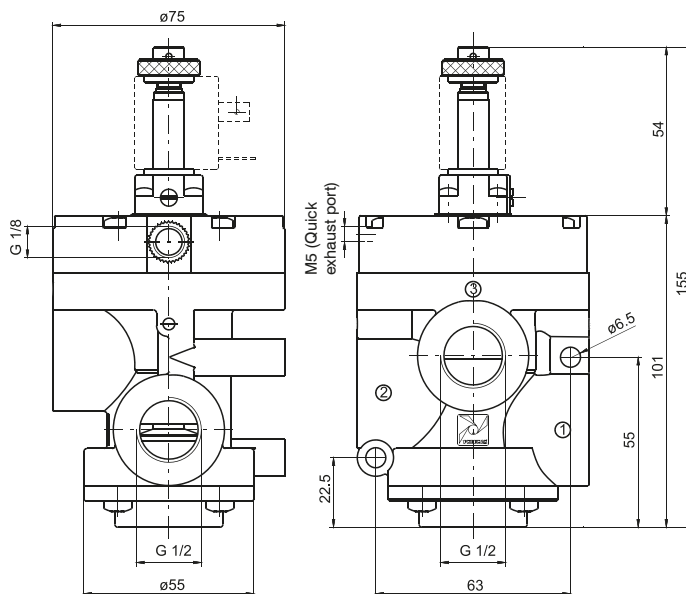

**For vacuum-N.O.**  
Outlet port 1  
Outlet port 2  
Pump 3

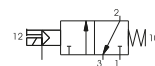

**For vacuum-N.C.**  
Exhaust port 3  
Outlet port 2  
Pump 1

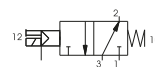

**Solenoid-Spring - External pilot with quick exhaust**

Coding: T772/VS.32.0.1.MP

Operational characteristics	
Fluid	Vacuum
Minimum piloting pressure (bar)	2,5
Temperature °C	-5 ... +50
Orifice size (mm)	15
Working ports size	G1/2"
Pilot ports size	G1/8"



Weight 390 g

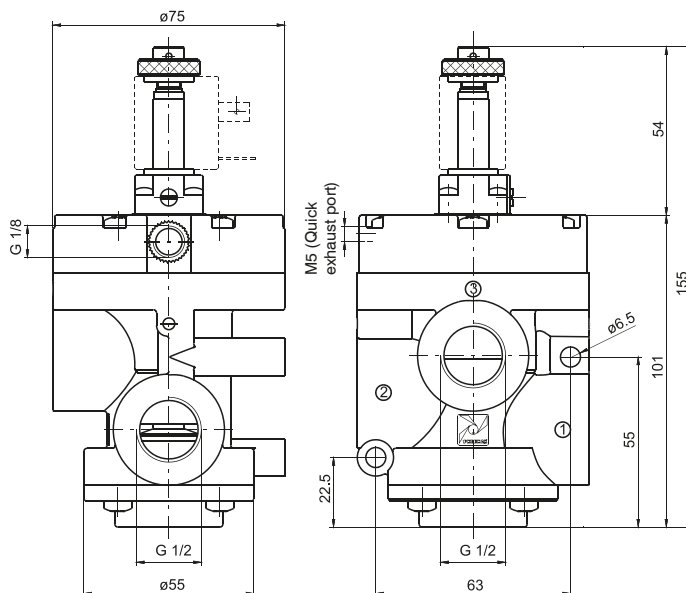

**For vacuum-N.O.**  
Outlet port 1  
Outlet port 2  
Pump 3

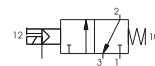

**For vacuum-N.C.**  
Exhaust port 3  
Outlet port 2  
Pump 1

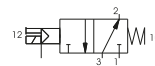



**Pneumatic - Spring**

Coding: T773.32.11.1

**Operational characteristics**

Fluid	Filtered and lubricated air or non
Max working pressure (bar)	10
Minimum piloting pressure (bar)	See diagram at general page
Temperature °C	-5 ... +50
Flow rate at 6 bar with Δp=1 (NI/min)	7500
Orifice size (mm)	20
Working ports size	G3/4"
Pilot ports size	G1/8"
Compressed air, purity class according to ISO 8573-1:2010	7:4:4

AIR DISTRIBUTION

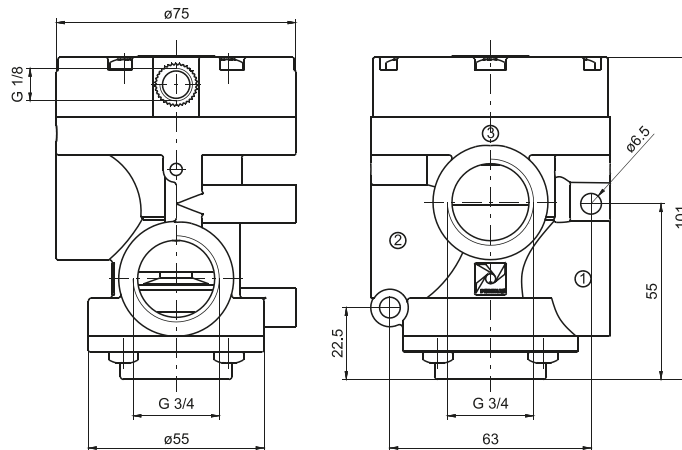

Weight 330 g

**For compressed air-N.C.**

Inlet port 1  
 Outlet port 2  
 Exhaust port 3

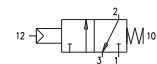

**For compressed air-N.O.**

Inlet port 3  
 Outlet port 2  
 Outlet port 1

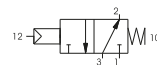

**Solenoid-Spring-Internal pilot**

Coding: T773.32.0. MP

**Operational characteristics**

Fluid	Filtered and lubricated air or non
Max working pressure (bar)	10
Minimum piloting pressure (bar)	2,5
Temperature °C	-5 ... +50
Flow rate at 6 bar with Δp=1 (NI/min)	7500
Orifice size (mm)	20
Working ports size	G3/4"
Pilot ports size	G1/8"

FUNCTION
1AA = Normally Open
1AC = Normally Closed

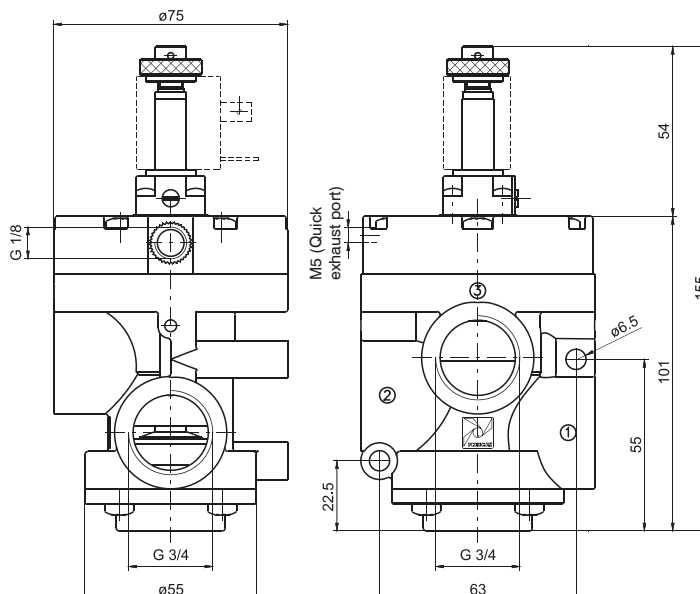

Weight 370 g

**For compressed air-N.C.**

Inlet port 1  
 Outlet port 2  
 Exhaust port 3

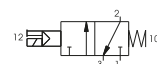

**For compressed air-N.O.**

Inlet port 3  
 Outlet port 2  
 Outlet port 1

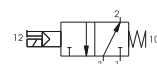

**Solenoid-Spring-External pilot**

Coding: T773.32.0.1.MP

Operational characteristics	
Fluid	Filtered and lubricated air or non
Max working pressure (bar)	10
Minimum piloting pressure (bar)	See diagram at general page
Temperature °C	-5 ... +50
Flow rate at 6 bar with $\Delta p=1$ (NI/min)	7500
Orifice size (mm)	20
Working ports size	G3/4"
Pilot ports size	G1/8"
Compressed air, purity class according to ISO 8573-1:2010	7:4:4



Weight 370 g

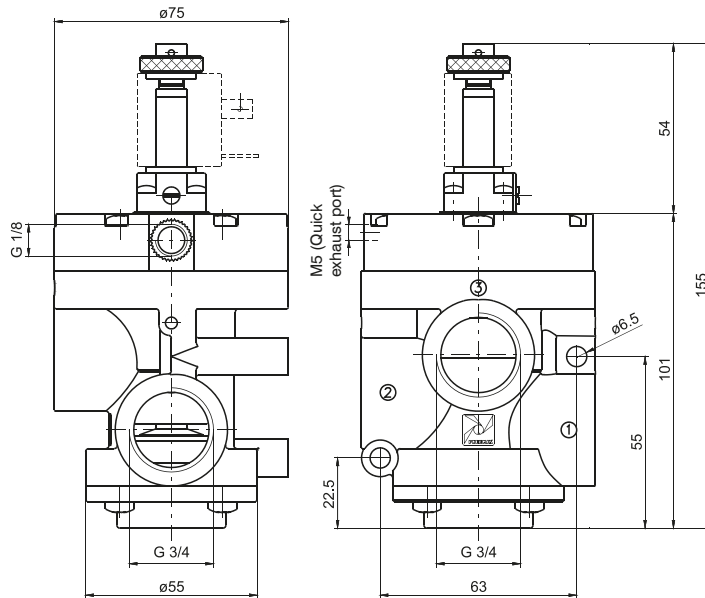

**For compressed air-N.C.**  
Inlet port 1  
Outlet port 2  
Exhaust port 3

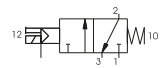

**For compressed air-N.O.**  
Inlet port 3  
Outlet port 2  
Outlet port 1

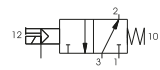

1  
AIR DISTRIBUTION

**Solenoid-Spring - Internal pilot with quick exhaust**

Coding: T773S.32.0.1.MP

Operational characteristics	
Fluid	Filtered and lubricated air or non
Max working pressure (bar)	10
Minimum piloting pressure (bar)	2,5
Temperature °C	-5 ... +50
Flow rate at 6 bar with $\Delta p=1$ (NI/min)	7500
Orifice size (mm)	20
Working ports size	G3/4"
Pilot ports size	G1/8"
Compressed air, purity class according to ISO 8573-1:2010	7:4:4

FUNCTION
<b>F</b> 1AA = Normally Open
1AC = Normally Closed



Weight 370 g

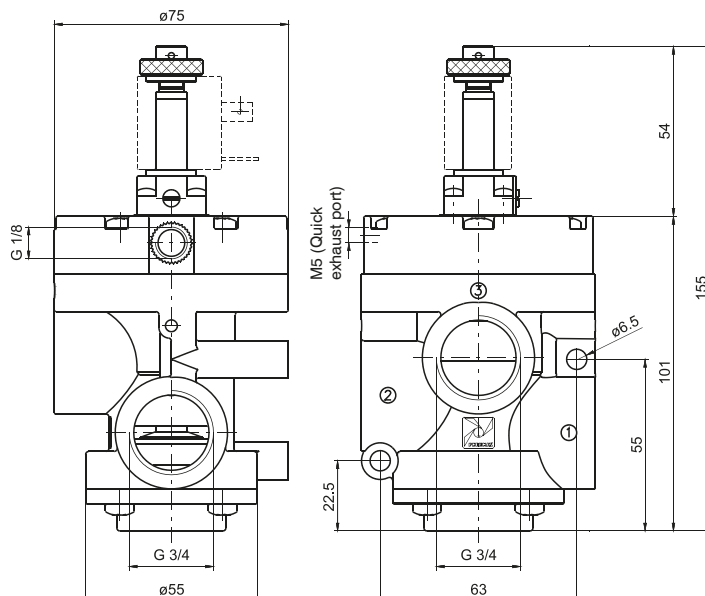

**For compressed air-N.C.**  
Inlet port 1  
Outlet port 2  
Exhaust port 3

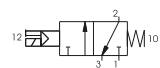

**For compressed air-N.O.**  
Inlet port 3  
Outlet port 2  
Outlet port 1

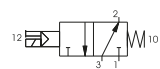



**Solenoid-Spring - External pilot with quick exhaust**

Coding: T773S.32.0.1.MP

**Operational characteristics**

Fluid	Filtered and lubricated air or non
Max working pressure (bar)	10
Minimum piloting pressure (bar)	See diagram at general page
Temperature °C	-5 ... +50
Flow rate at 6 bar with Δp=1 (NI/min)	7500
Orifice size (mm)	20
Working ports size	G3/4"
Pilot ports size	G1/8"
Compressed air, purity class according to ISO 8573-1:2010	7:4:4

1

AIR DISTRIBUTION



Weight 370 g

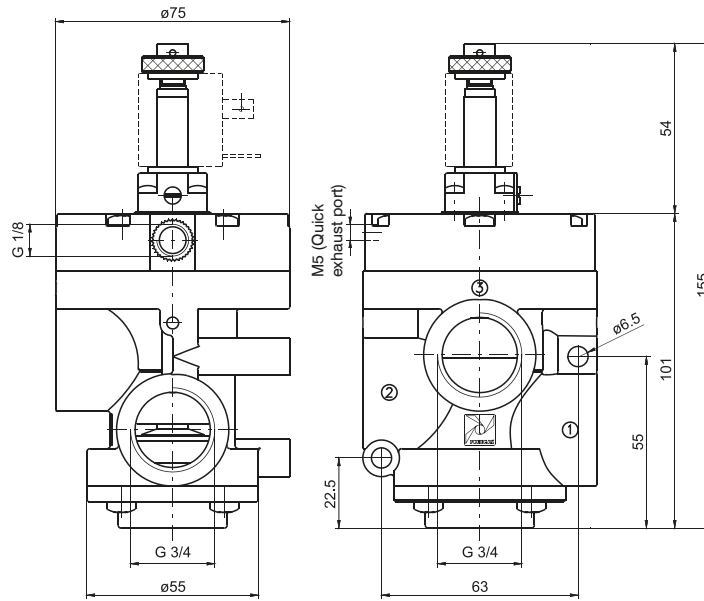

**For compressed air-N.C.**

- Inlet port 1
- Outlet port 2
- Exhaust port 3

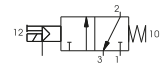

**For compressed air-N.O.**

- Inlet port 3
- Outlet port 2
- Outlet port 1

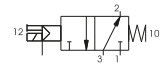

**Pneumatic - Spring**

Coding: T773/V.32.11.1

Operational characteristics	
Fluid	Vacuum
Minimum piloting pressure (bar)	2,5
Temperature °C	-5 ... +50
Orifice size (mm)	20
Working ports size	G3/4"
Pilot ports size	G1/8"



Weight 330 g

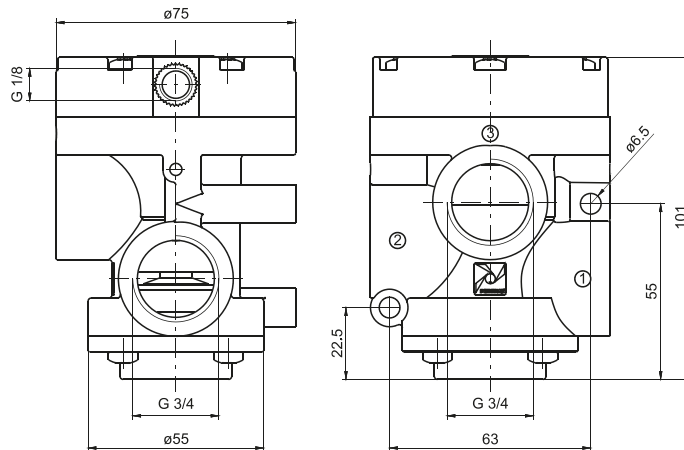

**For vacuum-N.C.**  
Exhaust port 3  
Outlet port 2  
Pump 1

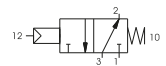

**For vacuum-N.O.**  
Outlet port 1  
Outlet port 2  
Pump 3

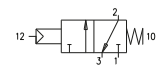

1

AIR DISTRIBUTION

**Solenoid-Spring-Internal pilot**

Coding: T773/V.32.0. MV

Operational characteristics	
Fluid	Vacuum
Temperature °C	-5 ... +50
Orifice size (mm)	20
Working ports size	G3/4"
Pilot ports size	G1/8"

FUNCTION
1AA = Normally Open
1AC = Normally Closed



Weight 370 g

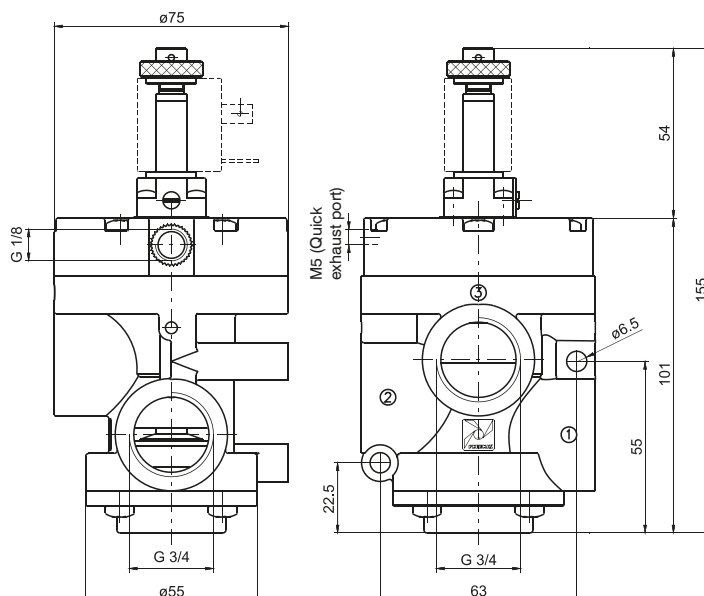

**For vacuum-N.O.**  
Exhaust port 3  
Outlet port 2  
Pump 1

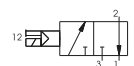

**For vacuum-N.C.**  
Outlet port 1  
Outlet port 2  
Pump 3

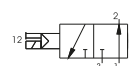



**Solenoid-Spring-External pilot**

Coding: T773/V.32.0.1.MP

Operational characteristics	
Fluid	Vacuum
Minimum piloting pressure (bar)	2,5
Temperature °C	-5 ... +50
Orifice size (mm)	20
Working ports size	G3/4"
Pilot ports size	G1/8"

1  
AIR DISTRIBUTION



Weight 350 g

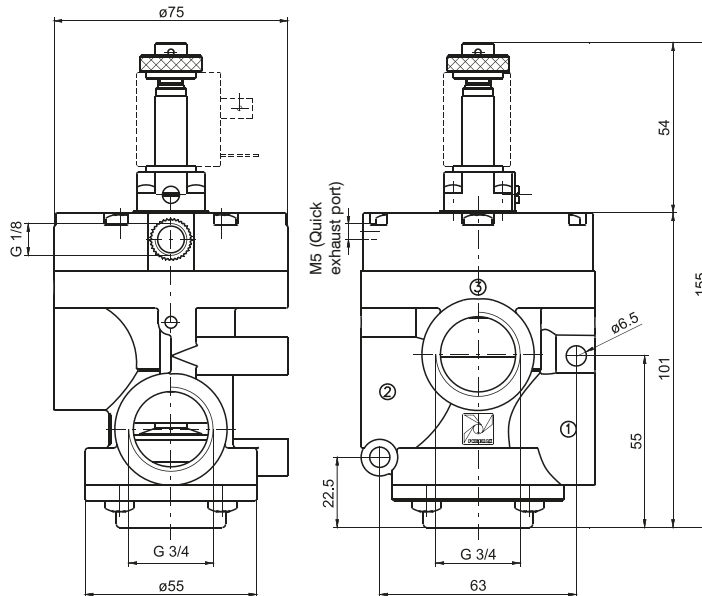

**For vacuum-N.O.**  
 Outlet port 1  
 Outlet port 2  
 Pump 3

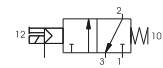

**For vacuum-N.C.**  
 Exhaust port 3  
 Outlet port 2  
 Pump 1

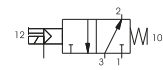

**Solenoid-Spring - External pilot with quick exhaust**

Coding: T773/VS.32.0.1.MP

Operational characteristics	
Fluid	Vacuum
Minimum piloting pressure (bar)	2,5
Temperature °C	-5 ... +50
Orifice size (mm)	20
Working ports size	G3/4"
Pilot ports size	G1/8"



Weight 350 g

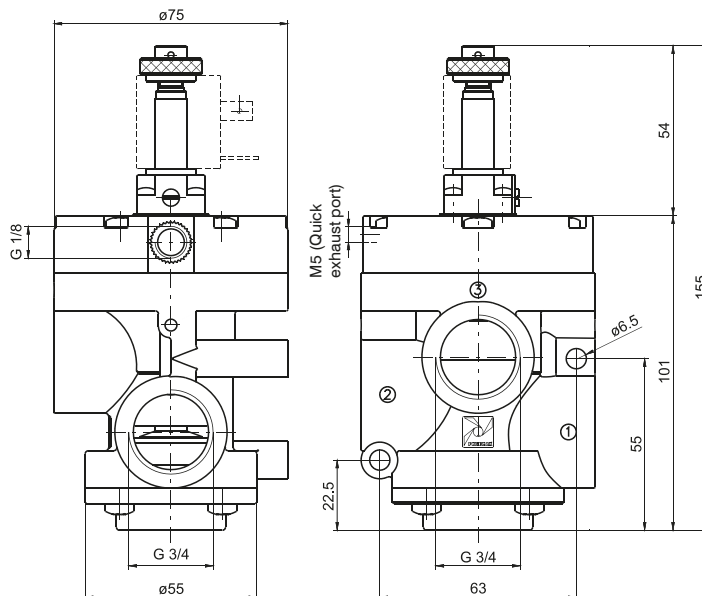

**For vacuum-N.O.**  
 Outlet port 1  
 Outlet port 2  
 Pump 3

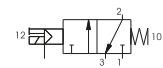

**For vacuum-N.C.**  
 Exhaust port 3  
 Outlet port 2  
 Pump 1

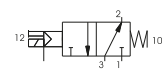



**Bistable for compressed air - G1/2"**

Coding: T772.32.0.1.BP

Operational characteristics	
Fluid	Filtered and lubricated air or non
Max working pressure (bar)	10
Minimum piloting pressure (bar)	2
Temperature °C	-5 ... +50
Flow rate at 6 bar with $\Delta p=1$ (NI/min)	4100
Orifice size (mm)	15
Working ports size	G1/2"
Pilot ports size	G1/8"
Compressed air, purity class according to ISO 8573-1:2010	7:4:4



Weight 550 g

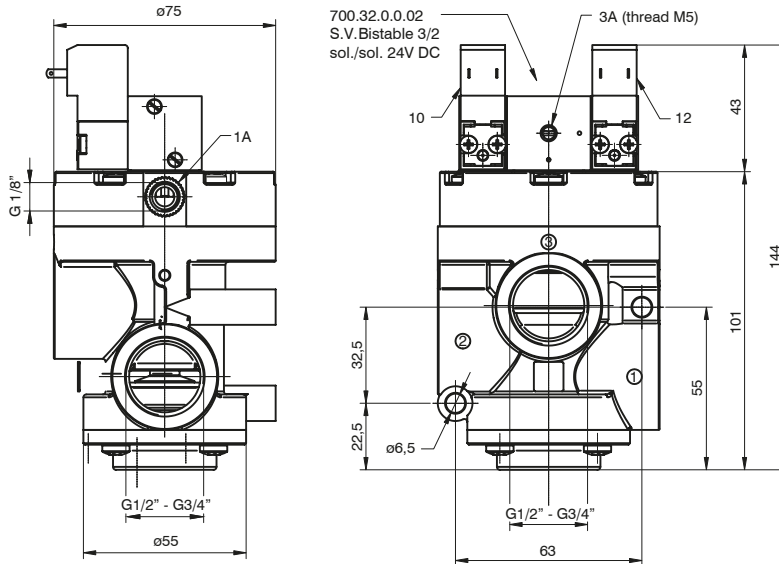

**For compressed air-N.C.**  
Inlet port 1  
Outlet port 2  
Exhaust port 3

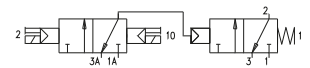

**For compressed air-N.O.**  
Inlet port 3  
Outlet port 2  
Outlet port 1

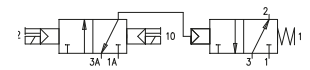

1  
AIR DISTRIBUTION

**Bistable for compressed air - G3/4"**

Coding: T773.32.0.1.BP

Operational characteristics	
Fluid	Filtered and lubricated air or non
Max working pressure (bar)	10
Minimum piloting pressure (bar)	2
Temperature °C	-5 ... +50
Flow rate at 6 bar with $\Delta p=1$ (NI/min)	7500
Orifice size (mm)	15
Working ports size	G3/4"
Pilot ports size	G1/8"
Compressed air, purity class according to ISO 8573-1:2010	7:4:4



Weight 550 g

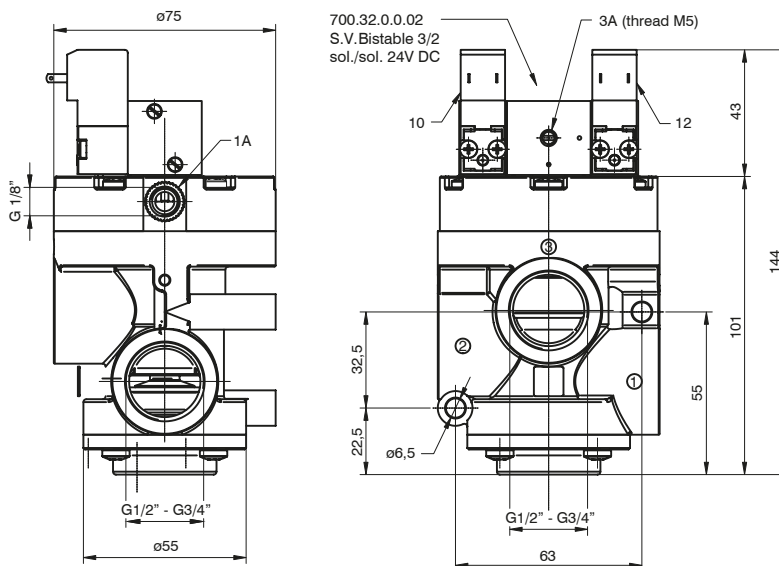

**For compressed air-N.C.**  
Inlet port 1  
Outlet port 2  
Exhaust port 3

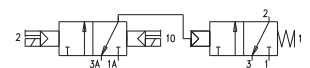

**For compressed air-N.O.**  
Inlet port 3  
Outlet port 2  
Outlet port 1

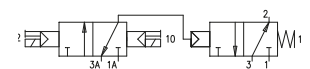



**Valves and solenoid valves poppet system**  
**Series T772-773 - Bistable for compressed air in technopolymer - G1/2" & G3/4"**

**Bistable for compressed air with quick exhaust - G1/2"**

Coding: T772S.32.0.1.BP

Operational characteristics	
Fluid	Filtered and lubricated air or non
Max working pressure (bar)	10
Minimum piloting pressure (bar)	2
Temperature °C	-5 ... +50
Flow rate at 6 bar with Δp=1 (NI/min)	4100
Orifice size (mm)	15
Working ports size	G1/2"
Pilot ports size	G1/8"
Compressed air, purity class according to ISO 8573-1:2010	7:4:4

AIR DISTRIBUTION



Weight 550 g

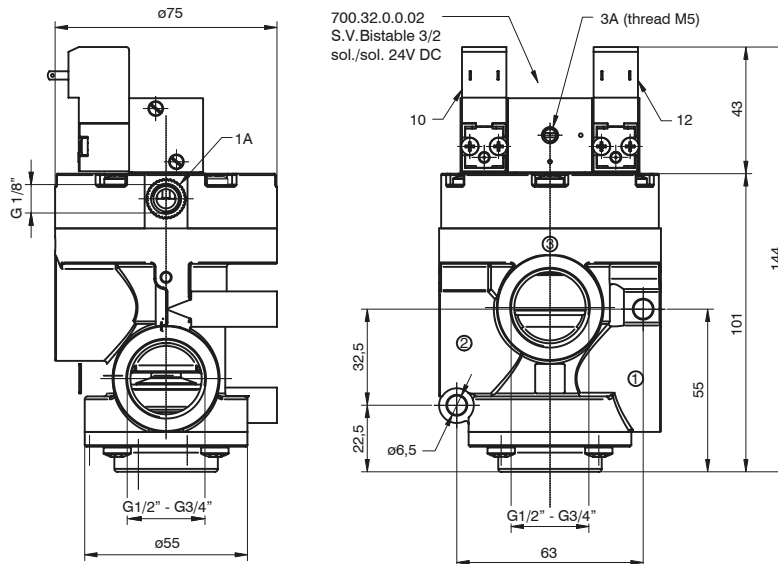

**For compressed air-N.C.**

Inlet port 1  
 Outlet port 2  
 Exhaust port 3

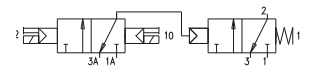

**For compressed air-N.O.**

Inlet port 3  
 Outlet port 2  
 Outlet port 1

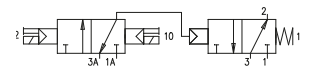

**Bistable for compressed air with quick exhaust G3/4"**

Coding: T773S.32.0.1.BP

Operational characteristics	
Fluid	Filtered and lubricated air or non
Max working pressure (bar)	10
Minimum piloting pressure (bar)	2
Temperature °C	-5 ... +50
Flow rate at 6 bar with Δp=1 (NI/min)	7500
Orifice size (mm)	15
Working ports size	G3/4"
Pilot ports size	G1/8"
Compressed air, purity class according to ISO 8573-1:2010	7:4:4



Weight 550 g

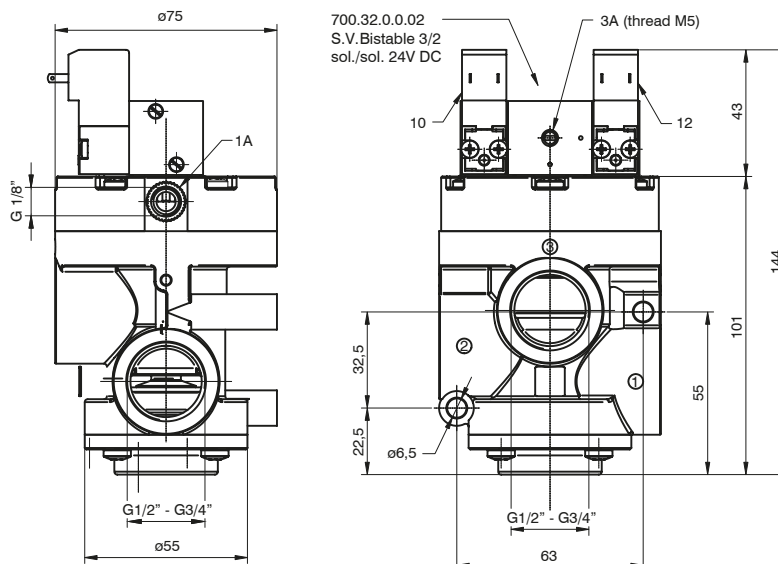

**For compressed air-N.C.**

Inlet port 1  
 Outlet port 2  
 Exhaust port 3

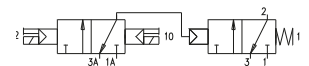

**For compressed air-N.O.**

Inlet port 3  
 Outlet port 2  
 Outlet port 1

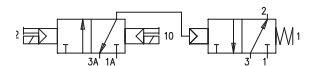

**Bistable for vacuum - G1/2"**

Coding: T772/V.32.0.1.BP

Operational characteristics	
Fluid	Vacuum
Minimum piloting pressure (bar)	2,5
Temperature °C	-5 ... +50
Orifice size (mm)	15
Working ports size	G1/2"
Pilot ports size	G1/8"

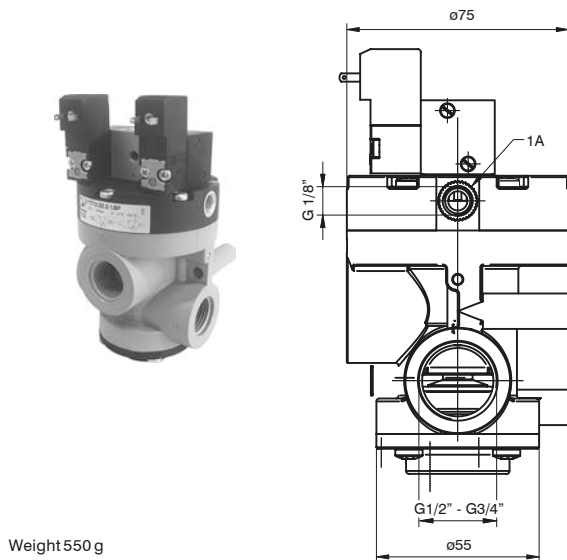

Weight 550 g

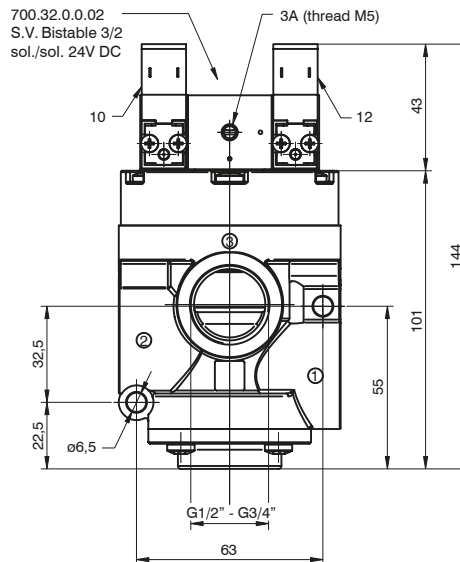

**For vacuum-N.C.**

- Pump 1
- Outlet port 2
- Exhaust port 3

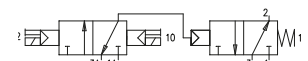

**For vacuum-N.O.**

- Pump 3
- Outlet port 2
- Outlet port 1

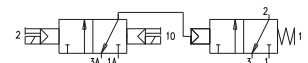

1  
AIR DISTRIBUTION

**Bistable for vacuum - G3/4"**

Coding: T773/V.32.0.1.BP

Operational characteristics	
Fluid	Vacuum
Minimum piloting pressure (bar)	2,5
Temperature °C	-5 ... +50
Orifice size (mm)	15
Working ports size	G3/4"
Pilot ports size	G1/8"

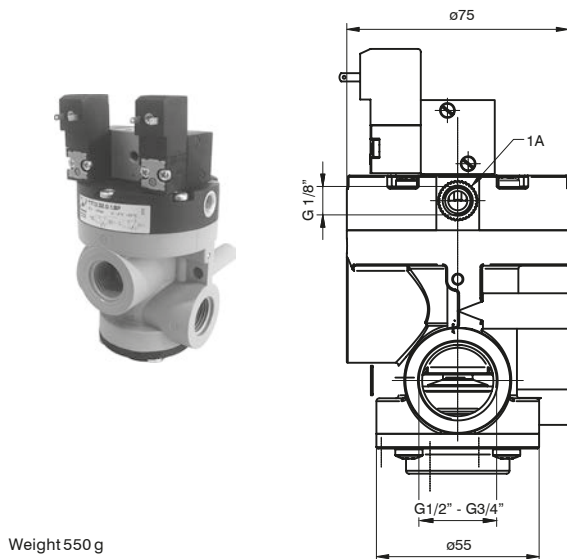

Weight 550 g

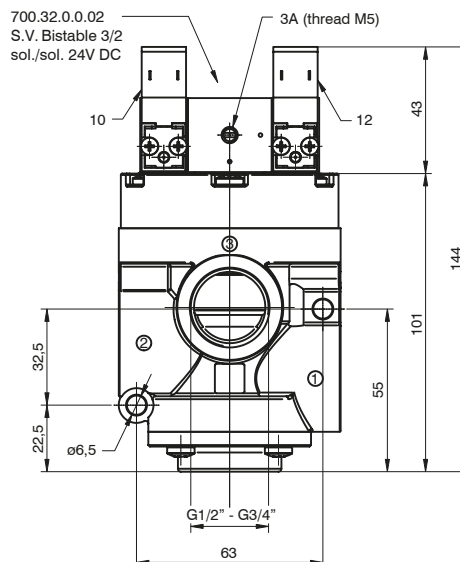

**For vacuum-N.C.**

- Pump 1
- Outlet port 2
- Exhaust port 3

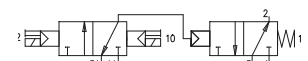

**For vacuum-N.O.**

- Pump 3
- Outlet port 2
- Outlet port 1

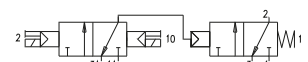



**Valves and solenoid valves poppet system**  
**Series T772-773 - Bistable for vacuum in technopolymer - G1/2" & G3/4"**

**Bistable for vacuum with quick exhaust - G1/2"**

Coding: T772/VS.32.0.1.BP

Operational characteristics	
Fluid	Vacuum
Minimum piloting pressure (bar)	2,5
Temperature °C	-5 ... +50
Orifice size (mm)	15
Working ports size	G1/2"
Pilot ports size	G1/8"

1  
AIR DISTRIBUTION



Weight 550 g

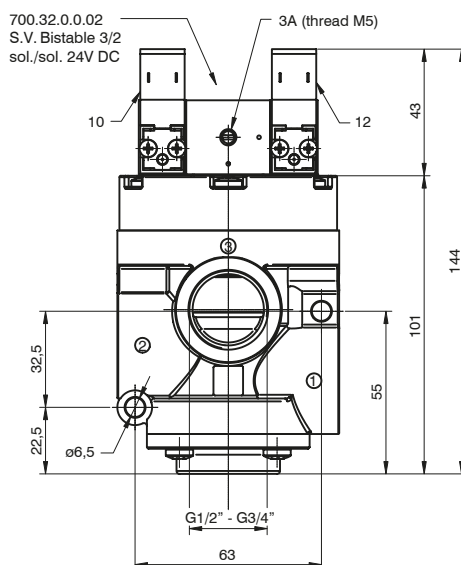
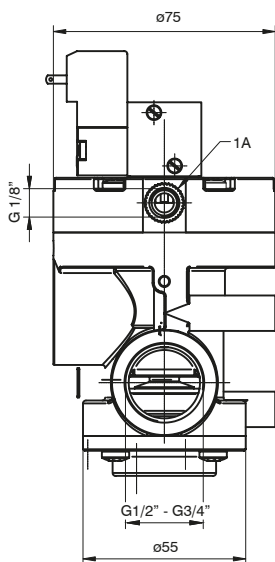

**For vacuum-N.C.**

- Pump 1
- Outlet port 2
- Exhaust port 3

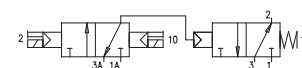

**For vacuum-N.O.**

- Pump 3
- Outlet port 2
- Outlet port 1

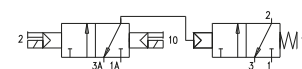

**Bistable for vacuum with quick exhaust - G3/4"**

Coding: T773/VS.32.0.1.BP

Operational characteristics	
Fluid	Vacuum
Minimum piloting pressure (bar)	2,5
Temperature °C	-5 ... +50
Orifice size (mm)	15
Working ports size	G3/4"
Pilot ports size	G1/8"



Weight 550 g

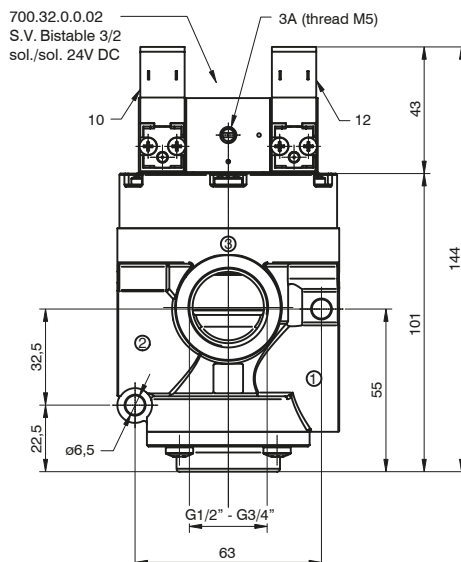
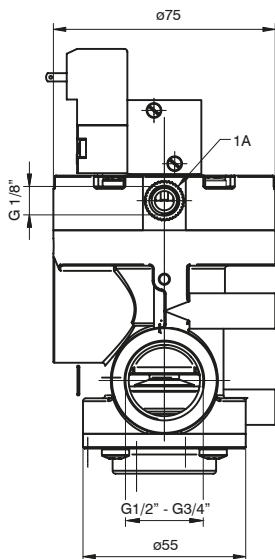

**For vacuum-N.C.**

- Pump 1
- Outlet port 2
- Exhaust port 3

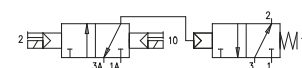

**For vacuum-N.O.**

- Pump 3
- Outlet port 2
- Outlet port 1

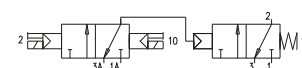



## Series T771 - for compressed air & vacuum in technopolymer - G1"

### General

The range of G1" pilot and solenoid operated poppet valves represents an evolution of the current popular Zama series and of the Series T772-T773 (G1/2"-3/4").

Also for this series the main feature is the technopolymer material used to mould most of its components.

The use of this material results in a versatile, lightweight and economical valve.

This series also has other technical and functional enhancements over the existing range. Firstly, the traditional piston lip seal has been replaced with a rolling diaphragm, thereby eliminating frictional wear and tear to this seal.

This series (with the exception of certain vacuum models) also features a seal, which separates port 3 from the piston head. The inclusion of this seal has enhanced the valve's performance and allows the valve to be used as normally open (a configuration not possible in the Zama series).

Solenoid operated valves (both internal and external pilot versions) are fitted with a quick exhaust unit, which reduces the return stroke operating time by 80%.

The bulk of the valves in this series use the MP type operator, the exception being internally piloted vacuum models, which use the MV operator.

These operators differ from the M2 type in that they have self-tapping mounting screws for use in plastics.

Bistable versions are also available, both for air or for vacuum. These valves are fitted with a 3/2 sol-sol valve (instead of the standard pilot valve) fitted with two 15mm 24V Dc microvalves (N331.0A).

**The ordering code are referring to the solenoid valves with mechanics "MP" or "MV" assembled.**

**Coils are not included and have to be ordered separately (series 300, Section 1, General Catalogue), with the exception of the bistable versions which already include 24V Dc Coils (N331.0A).**

**Coils CE marked are homologated are available (see 300 Series).**

### Construction characteristics

Body, operator and end cover	High impact resistant thermoplastic
Seals and poppets	NBR
Diaphragm	Oil resistant rubber (NBR)
Springs	AISI 302 stainless steel
Piston and shaft	Acetal resin

### Use and maintenance

These valves have a mean life of 10 to 15 million cycles under normal operating conditions.

Lubrication is not required for good operation but we recommend good filtration to avoid dirty deposit causing malfunction.

Please ensure that the valve is being used according with the manufacturers specification, such as air pressure and temperature.

The exhaust port of the distributor has to be protected in a dusty and dirty environment.

For these products, according to the construction technique and special application, is not required any maintenance with parts replacement.

When necessary it is sufficient to clean the internal parts.

When it is used the solenoid valves with internal pilot, either for air or vacuum, inlet flow rate must be equal or higher that the required consumption flow rate.

Otherwise is better choose the external pilot version.

### MINIMUM PILOTING PRESSURE DIAGRAM (Valves for compressed air) PNEUMATIC/SRING AND EXTERNAL SOLENOID PILOT VERSION

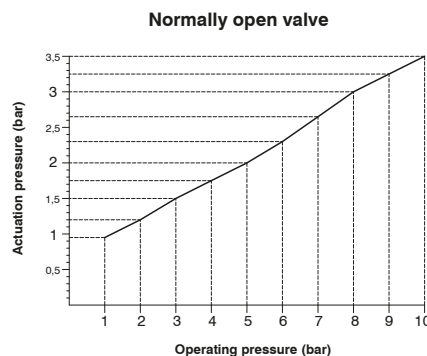
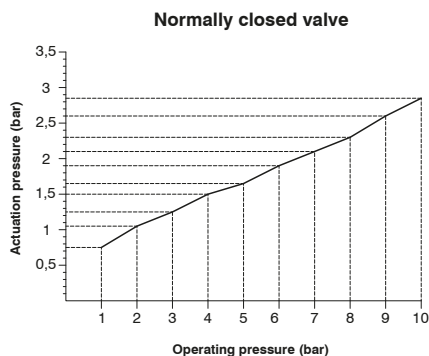



# Valves and solenoid valves poppet system

## Series T771 - for compressed air in technopolymer - G1"

### Pneumatic - Spring

Coding: T771.32.11.1

#### Operational characteristics

Fluid	Filtered and lubricated air or non
Max working pressure (bar)	10
Minimum piloting pressure (bar)	See diagram at general page
Temperature °C	-5 ... +50
Flow rate at 6 bar with $\Delta p=1$ (NI/min)	12500
Orifice size (mm)	25
Working ports size	G1"
Pilot ports size	G1/8"
Compressed air, purity class according to ISO 8573-1:2010	7:4:4

1

AIR DISTRIBUTION

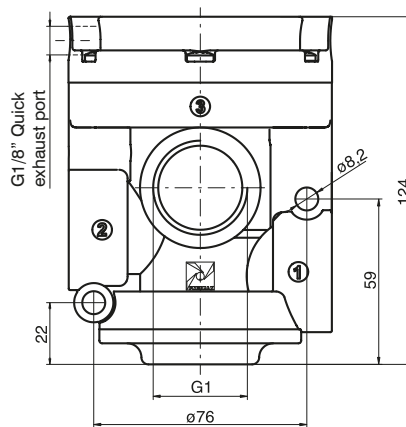
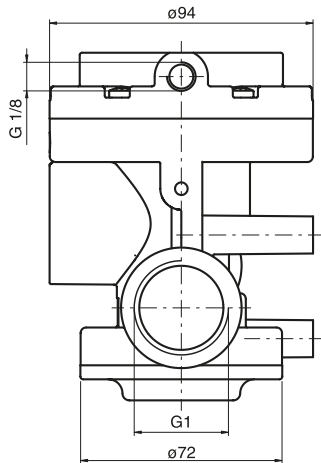

For compressed air-N.C.

Inlet port 1  
Outlet port 2  
Exhaust port 3

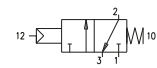

For compressed air-N.O.

Inlet port 3  
Outlet port 2  
Outlet port 1

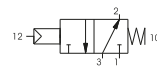

Weight 480 g

### Solenoid-Spring-Internal pilot

Coding: T771.32.0. MP

#### Operational characteristics

Fluid	Filtered and lubricated air or non
Max working pressure (bar)	10
Minimum piloting pressure (bar)	2,5
Temperature °C	-5 ... +50
Flow rate at 6 bar with $\Delta p=1$ (NI/min)	12500
Orifice size (mm)	25
Working ports size	G1"
Pilot ports size	G1/8"
Compressed air, purity class according to ISO 8573-1:2010	7:4:4

	FUNCTION
	1AC = Normally Closed
	1AA = Normally Open

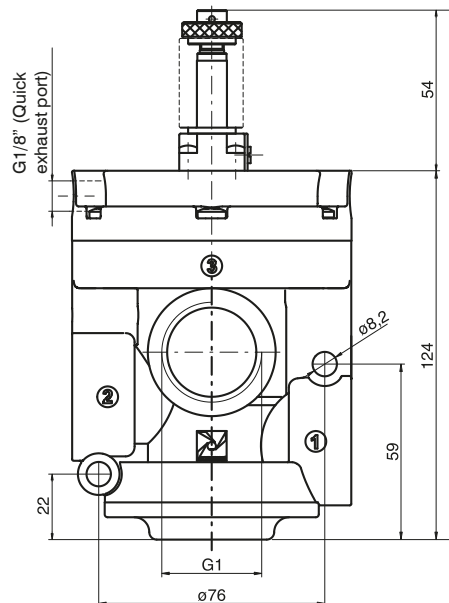
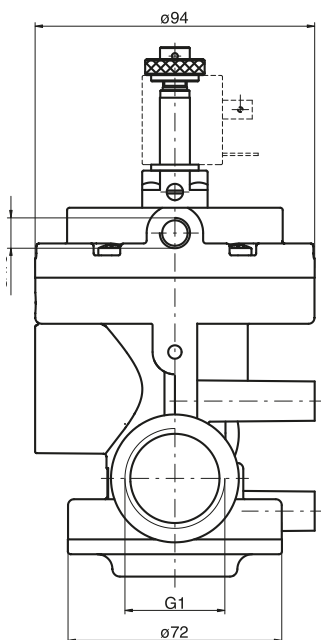

For compressed air-N.C.

Inlet port 1  
Outlet port 2  
Exhaust port 3

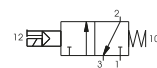

For compressed air-N.O.

Inlet port 3  
Outlet port 2  
Outlet port 1

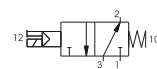

Weight 520 g

**Solenoid-Spring-External pilot**

Coding: T771.32.0.1.MP

Operational characteristics	
Fluid	Filtered and lubricated air or non
Max working pressure (bar)	10
Minimum piloting pressure (bar)	See diagram at general page
Temperature °C	-5 ... +50
Flow rate at 6 bar with $\Delta p=1$ (NI/min)	12500
Orifice size (mm)	25
Working ports size	G1"
Pilot ports size	G1/8"
Compressed air, purity class according to ISO 8573-1:2010	7:4:4

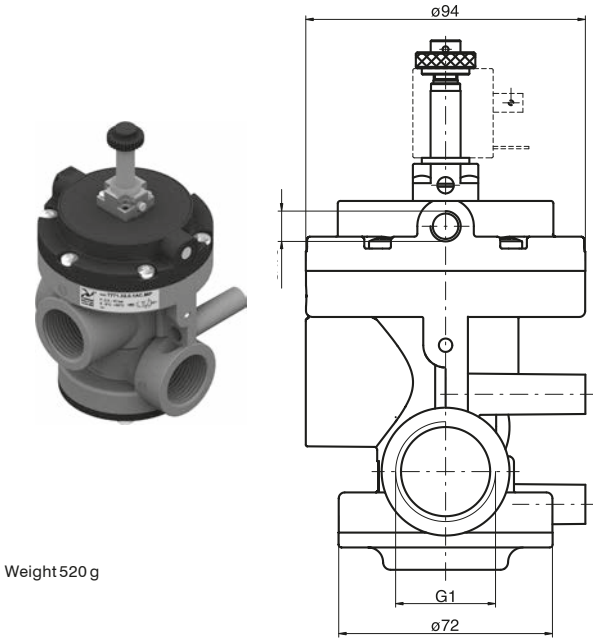

Weight 520 g

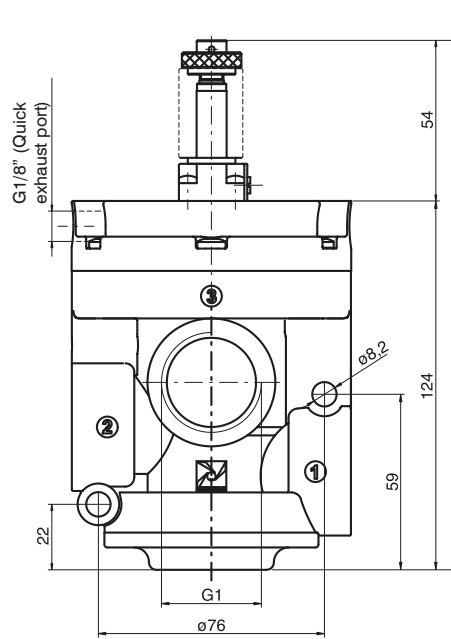

**For compressed air-N.C.**  
Inlet port 1  
Outlet port 2  
Exhaust port 3

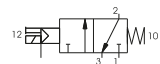

**For compressed air-N.O.**  
Inlet port 3  
Outlet port 2  
Outlet port 1

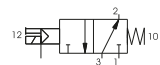

**Solenoid-Spring - Internal pilot with quick exhaust**

Coding: T771S.32.0.1.MP

Operational characteristics	
Fluid	Filtered and lubricated air or non
Max working pressure (bar)	10
Minimum piloting pressure (bar)	2,5
Temperature °C	-5 ... +50
Flow rate at 6 bar with $\Delta p=1$ (NI/min)	12500
Orifice size (mm)	25
Working ports size	G1"
Pilot ports size	G1/8"
Compressed air, purity class according to ISO 8573-1:2010	7:4:4

FUNCTION
<b>F</b> 1AC = Normally Closed
1AA = Normally Open

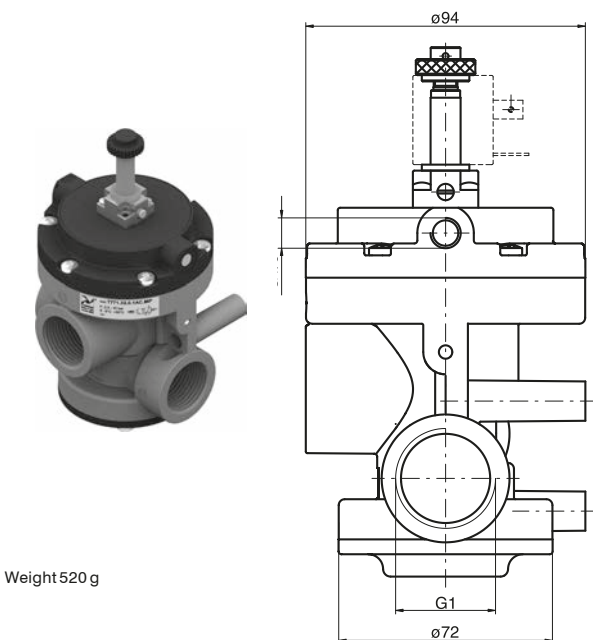

Weight 520 g

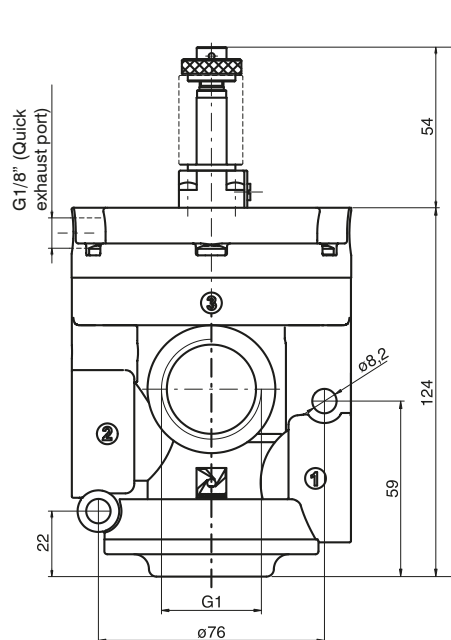

**For compressed air-N.C.**  
Inlet port 1  
Outlet port 2  
Exhaust port 3

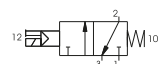

**For compressed air-N.O.**  
Inlet port 3  
Outlet port 2  
Outlet port 1

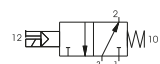



**Solenoid-Spring - External pilot with quick exhaust**

Coding: T771S.32.0.1.MP

**Operational characteristics**

Fluid	Filtered and lubricated air or non
Max working pressure (bar)	10
Minimum piloting pressure (bar)	See diagram at general page
Temperature °C	-5 ... +50
Flow rate at 6 bar with $\Delta p=1$ (NI/min)	12500
Orifice size (mm)	25
Working ports size	G1"
Pilot ports size	G1/8"
Compressed air, purity class according to ISO 8573-1:2010	7:4:4

1  
AIR DISTRIBUTION



Weight 520 g

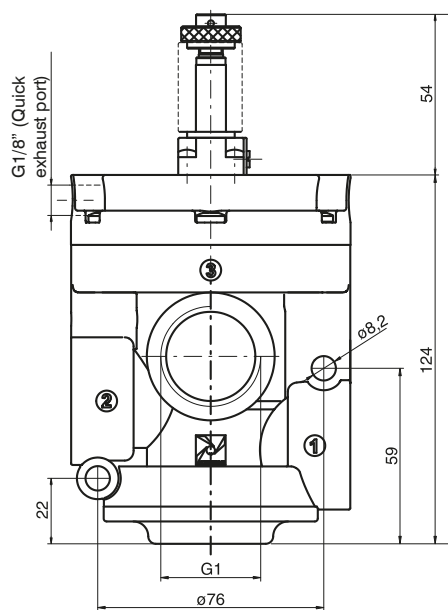
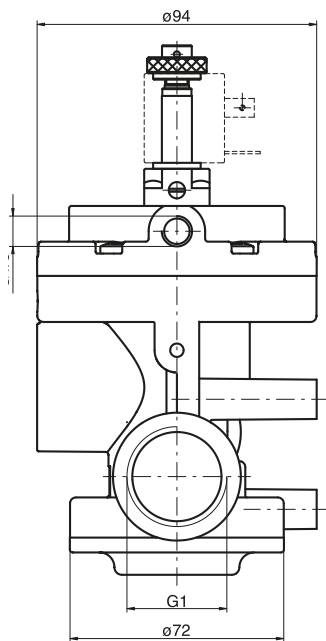

**For compressed air-N.C.**

- Inlet port 1
- Outlet port 2
- Exhaust port 3

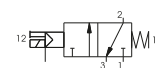

**For compressed air-N.O.**

- Inlet port 3
- Outlet port 2
- Outlet port 1

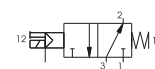



**Pneumatic - Spring**

Coding: T771/V.32.11.1

Operational characteristics	
Fluid	Vacuum
Minimum piloting pressure (bar)	2
Temperature °C	-5 ... +50
Orifice size (mm)	25
Working ports size	G1"
Pilot ports size	G1/8"

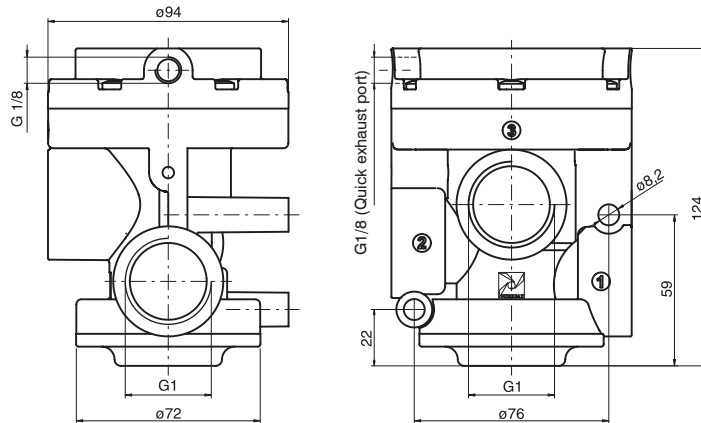

Weight 480 g

**For vacuum-N.C.**  
Exhaust port 3  
Outlet port 2  
Pump 1

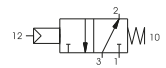

**For vacuum-N.O.**  
Outlet port 1  
Outlet port 2  
Pump 3

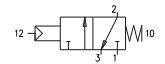

1

AIR DISTRIBUTION

**Solenoid-Spring-Internal pilot**

Coding: T771/V.32.0.F.MV

Operational characteristics	
Fluid	Vacuum
Temperature °C	-5 ... +50
Orifice size (mm)	25
Working ports size	G1"
Pilot ports size	G1/8"

FUNCTION
<b>F</b> 1AC = Normally Closed
1AA = Normally Open

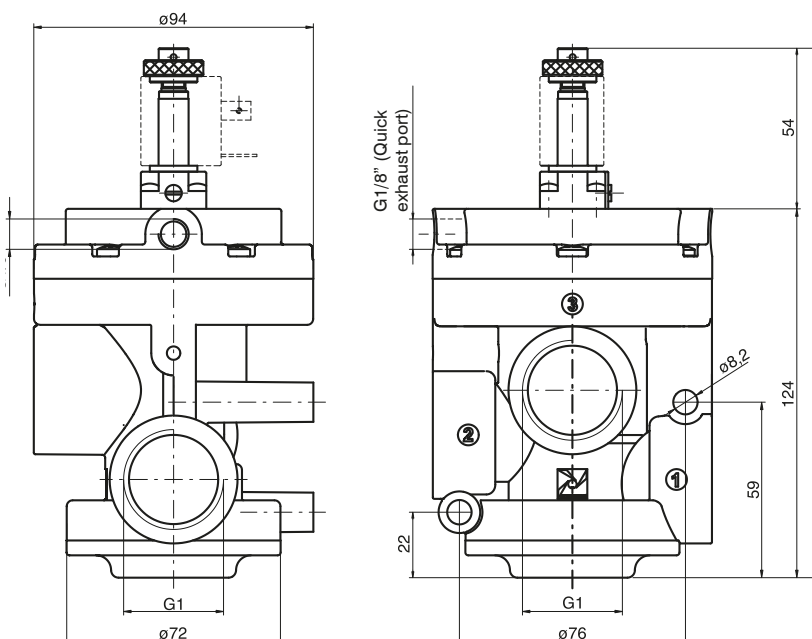

Weight 520 g

**For vacuum-N.O.**  
Exhaust port 3  
Outlet port 2  
Pump 1

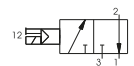

**For vacuum-N.C.**  
Outlet port 1  
Outlet port 2  
Pump 3

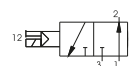



**Solenoid-Spring-External pilot**

Coding: T771/V.32.0.1.MP

Operational characteristics	
Fluid	Vacuum
Minimum piloting pressure (bar)	2
Temperature °C	-5 ... +50
Orifice size (mm)	25
Working ports size	G1"
Pilot ports size	G1/8"

1  
AIR DISTRIBUTION



Weight 520 g

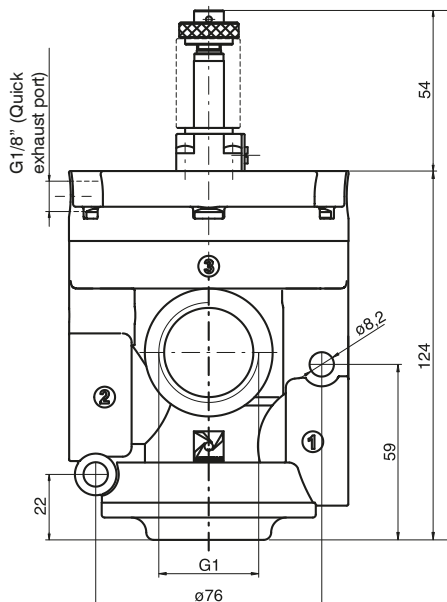
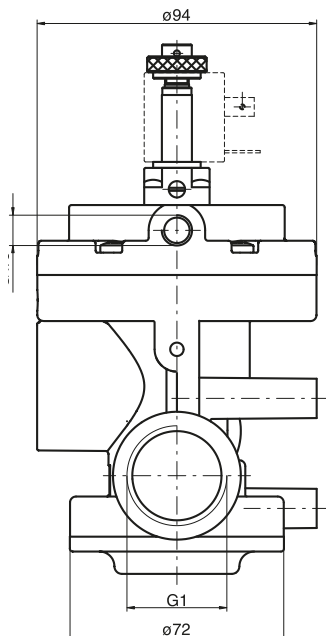

**For vacuum-N.O.**  
Pump 3  
Outlet port 2  
Outlet port 1

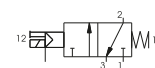

**For vacuum-N.C.**  
Pump 1  
Outlet port 2  
Exhaust port 3

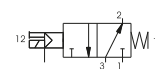

**Solenoid-Spring - External pilot with quick exhaust**

Coding: T771/VS.32.0.1.MP

Operational characteristics	
Fluid	Vacuum
Minimum piloting pressure (bar)	2
Temperature °C	-5 ... +50
Orifice size (mm)	25
Working ports size	G1"
Pilot ports size	G1/8"



Weight 520 g

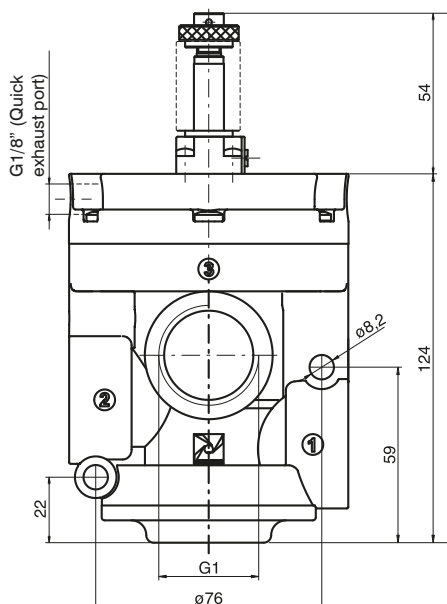
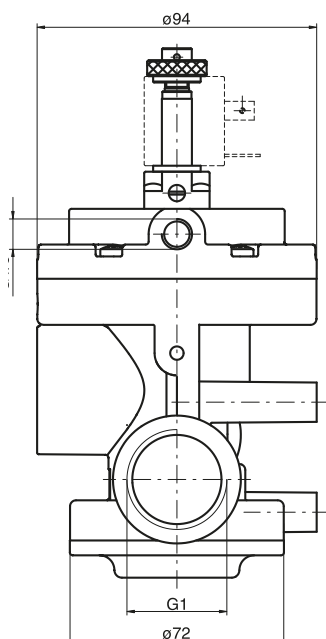

**For vacuum-N.O.**  
Pump 3  
Outlet port 2  
Outlet port 1

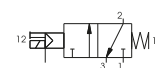

**For vacuum-N.C.**  
Pump 1  
Outlet port 2  
Exhaust port 3

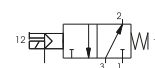

**Bistable for compressed air - G1"**

Coding: T771.32.0.1.BP

Operational characteristics	
Fluid	Filtered and lubricated air or non
Max working pressure (bar)	10
Minimum piloting pressure (bar)	2.5
Temperature °C	-5 ... +50
Flow rate at 6 bar with Δp=1 (NI/min)	12500
Orifice size (mm)	25
Working ports size	G1"
Pilot ports size	G1/8"
Compressed air, purity class according to ISO 8573-1:2010	7:4:4



Weight 680 g

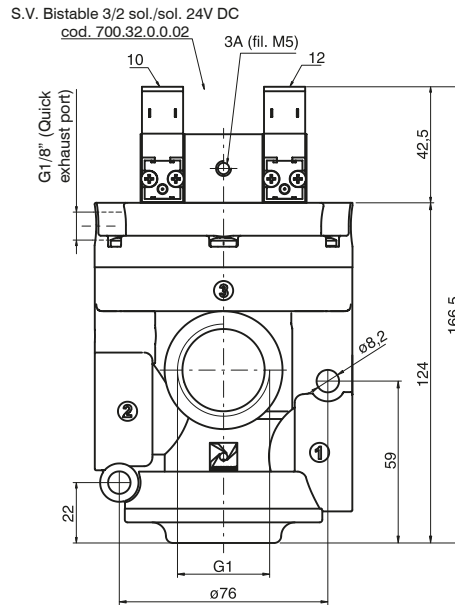
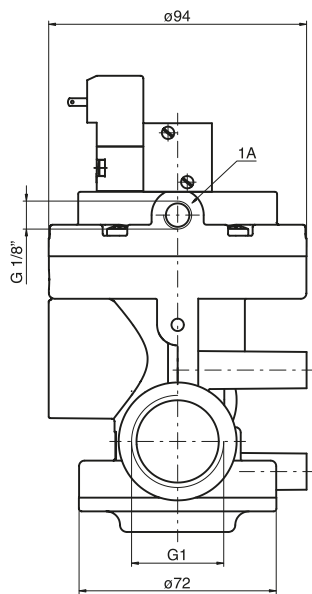

Minimum piloting pressure 2.5 bar

**For compressed air-N.C.**

- Inlet port 1
- Outlet port 2
- Exhaust port 3

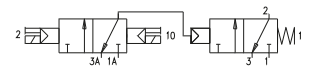

**For compressed air-N.O.**

- Inlet port 3
- Outlet port 2
- Outlet port 1

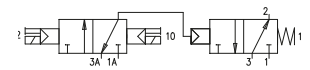

**Bistable for compressed air with quick exhaust - G1"**

Coding: T771S.32.0.1.BP

Operational characteristics	
Fluid	Filtered and lubricated air or non
Max working pressure (bar)	10
Minimum piloting pressure (bar)	2.5
Temperature °C	-5 ... +50
Flow rate at 6 bar with Δp=1 (NI/min)	12500
Orifice size (mm)	25
Working ports size	G1"
Pilot ports size	G1/8"
Compressed air, purity class according to ISO 8573-1:2010	7:4:4



Weight 680 g

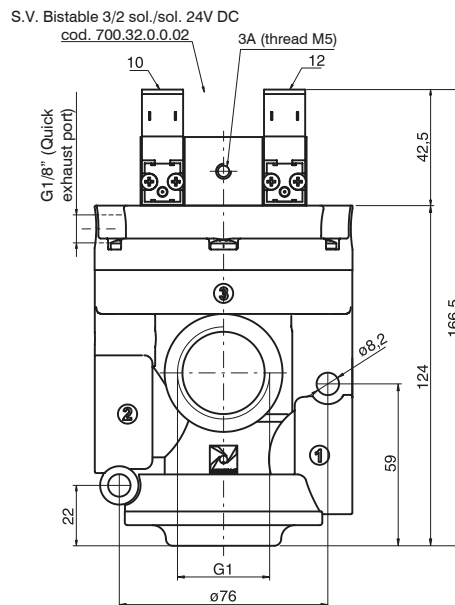
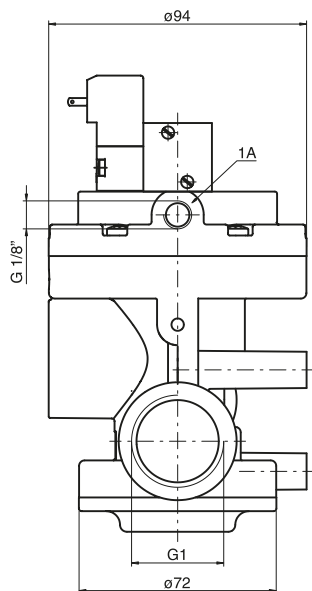

**For compressed air-N.C.**

- Inlet port 1
- Outlet port 2
- Exhaust port 3

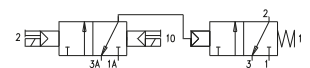

**For compressed air-N.O.**

- Inlet port 3
- Outlet port 2
- Outlet port 1

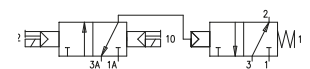



**Bistable for vacuum - G1"**

Coding: T771/V.32.0.1.BP

Operational characteristics	
Fluid	Vacuum
Minimum piloting pressure (bar)	2,5
Temperature °C	-5 ... +50
Orifice size (mm)	25
Working ports size	G1"
Pilot ports size	G1/8"

1  
AIR DISTRIBUTION



Weight 680 g

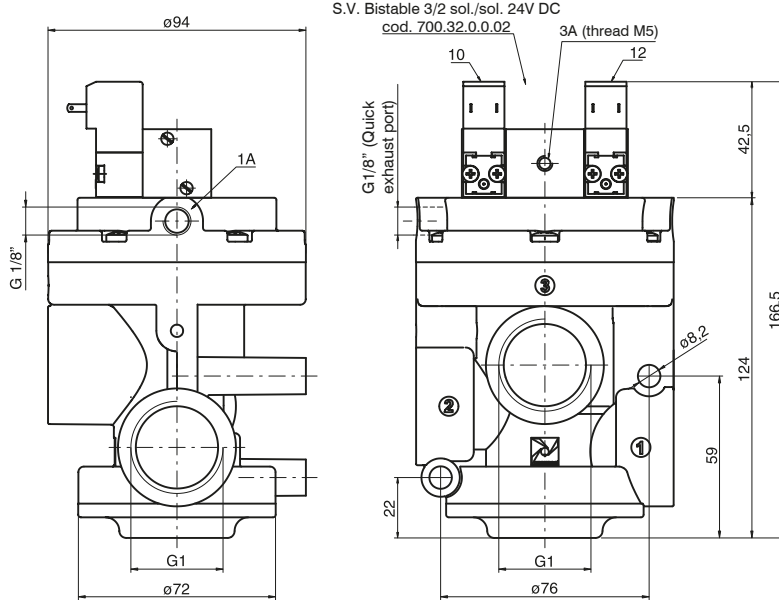

Minimum piloting pressure 2.5 bar

**For vacuum-N.C.**

- Pump 1
- Outlet port 2
- Exhaust port 3

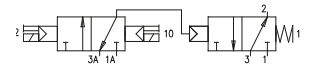

**For vacuum-N.O.**

- Pump 3
- Outlet port 2
- Outlet port 1

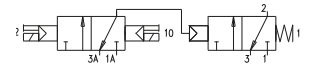

**Bistable for vacuum with quick exhaust - G1"**

Coding: T771/VS.32.0.1.BP

Operational characteristics	
Fluid	Vacuum
Minimum piloting pressure (bar)	2,5
Temperature °C	-5 ... +50
Orifice size (mm)	25
Working ports size	G1"
Pilot ports size	G1/8"



Weight 680 g

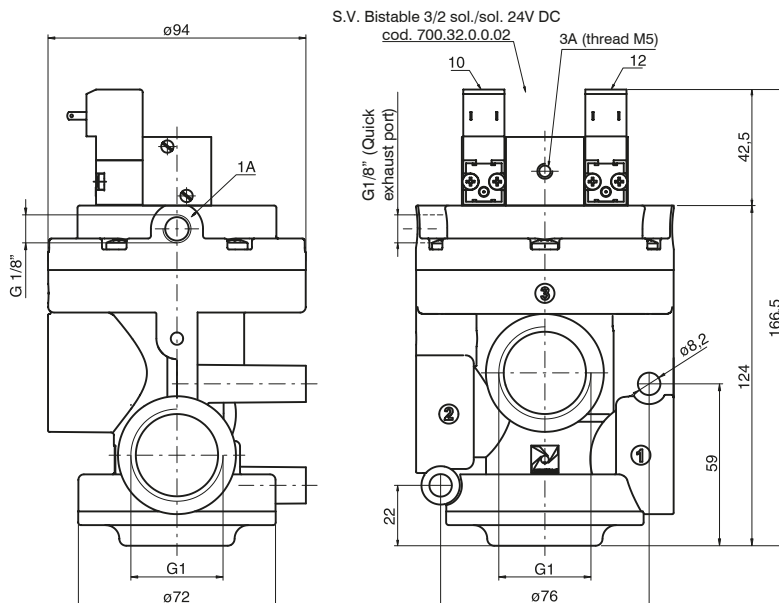

**For vacuum-N.C.**

- Pump 1
- Outlet port 2
- Exhaust port 3

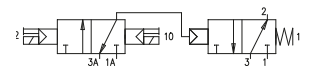

**For vacuum-N.O.**

- Pump 3
- Outlet port 2
- Outlet port 1

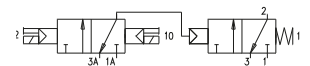



## Series PVA - Pad valve for air 2/2

### General

Pad Valves offer a reliable and economic solution to fluid control. The valve is manufactured with a 2 way Bronze body and actuated pneumatically using either a single or double acting compact cylinder which can be rotated 360°.

Versions are available with NBR, FPM or PTFE valve seals.

The barrel profile allows the use of magnetic sensors code "1500.\_", "RS.\_", "HS.\_", for slots "A" type. (see the Pneumax General catalogue, chapter 3).

### Construction characteristics

Bushing, Bushing pad, Nut pad	Brass
Cylinder	Aluminium alloy Anodized
Rear eye, Piston and Rod bushing	Anodized aluminium
Seals in contact with fluid	NBR, FPM, PTFE
Pneumatic cylinder seals	NBR, FPM, PTFE
Springs	Zinc plated steel
Piston rod	Chromed stainless steel

### Technical characteristics

Pneumatic cylinder fluid	Filtered air. No lubrication needed, if applied it shall be continuous
Valve fluid	Fluid compatible with gasket compounds available
Working pressure (Cylinder) (bar)	10
Temperature °C, non magnetic piston, NBR seals	-10 / + 70
Temperature °C, non magnetic piston, FPM seals	-10 / + 150
Temperature °C, non magnetic piston, PTFE seals	-10 / + 150
Temperature °C, magnetic piston,, NBR, FPM, PTFE seals	-10 / + 70



"T" body version Pad valves

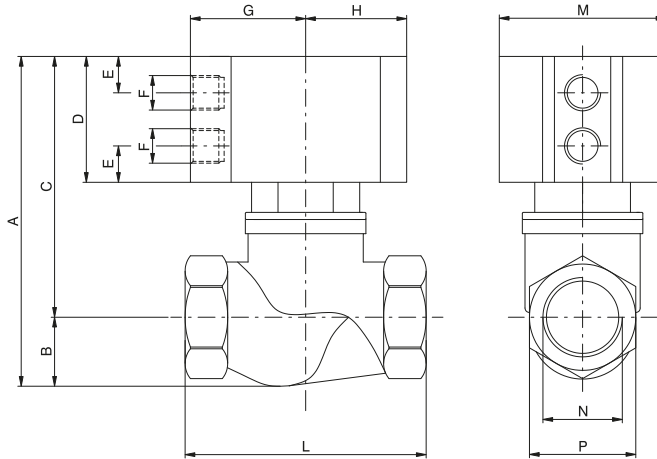

Ordering code	
<b>PVA.B.A.P.T.C.S</b>	
ACTING	
<b>A</b>	DE=Double acting SC=Normally closed SA=Normally OPEN
PISTON	
<b>P</b>	N=Non magnetic M= Magnetic
CONNECTIONS	
<b>C</b>	A=G1/4" B=G3/8" C=G1/2" D=G3/4" E=G1" F=G1 1/4" G=G1 1/2" H=G2"
SEALS	
<b>S</b>	N=NBR V=FPM F=PTFE

TABLE OF DIMENSIONS

Connection (N)	Non magnetic version			Magnetic version			TECHNICAL DATA										
	A	C	D	A	C	D	B	E	F	G	H	L	M	P	Actuator (Ø)	Nominal Valve (Ø)	Weight (gr.)
G1/4"	93,5	77,5	41	97,5	81,5	45	16	10,25	G1/8"	32,5	28,5	64	47	25	Ø40	Ø13,5	350
G3/8"	93,5	77,5	41	97,5	81,5	45	16	10,25	G1/8"	32,5	28,5	64	47	25	Ø40	Ø13,5	350
G1/2"	93,5	78	41	99,5	82	45	17,5	10,25	G1/8"	32,5	28,5	68	47	30	Ø40	Ø15	400
G 3/4"	105	83	41	113	90	48	22	11,25	G1/8"	44	40	79	70	36	Ø63	Ø20,5	850
G1"	117	89	41	125	101	53	28	11,25	G1/8"	44	40	94	70	44	Ø63	Ø25	1100
G1 1/4"	131	103	48	136	108	53	28	11,25	G1/8"	44	40	110	70	55	Ø63	Ø30	1400
G1 1/2"	154	118	57	166	130	69	36	13,75	G1/8"	56	49	120	90	60	Ø80	Ø38	2100
G2"	169	124	57	181	136	69	45	13,75	G1/8"	56	49	140	90	73	Ø80	Ø49,5	3000

Pad valves, 2-ways, are a reliable and economic solution to control fluid. Pneumatically actuated by a compact double or single acting cylinder with 360° revolving connections. Standard seals in contact with fluid are made in NBR, FPM or PTFE. The barrel profile allows the use of Pneumax magnetic sensors series 1500 (see the Sensors Section).

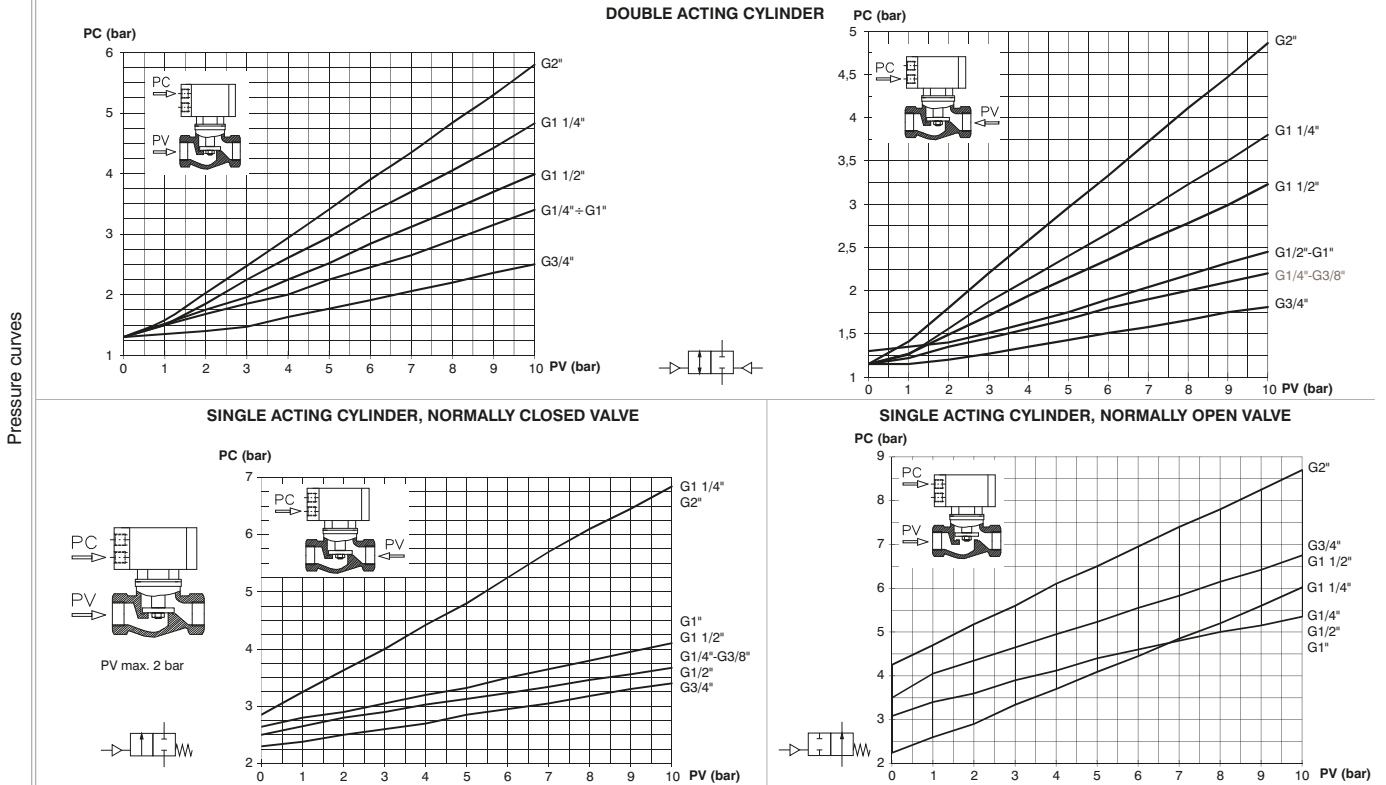

Operational characteristics

- Rear eye, Piston and Rod bushing = Anodized aluminium
- Cylinder = Aluminium alloy Anodized
- Spring = Zinc plated steel
- Seals = NBR, FPM, PTFE
- Piston rod = Chromed stainless steel
- Bushing, Bushing pad, Nut pad = Brass

Technical characteristics

Fluid	Filtered air.
Maximum working pressure (bar)	No lubrication needed, if applied it shall be continuous.
Temperature °C (non magnetic piston, NBR seals)	-5 / + 70
Temperature °C (non magnetic piston, FPM seals)	-10 / + 150
Temperature °C (non magnetic piston, PTFE seals)	-5 / + 150
Temperature °C (magnetic piston, NBR, FPM, PTFE seals)	-10 / + 70

AIR DISTRIBUTION

"Y" body version Pad valves

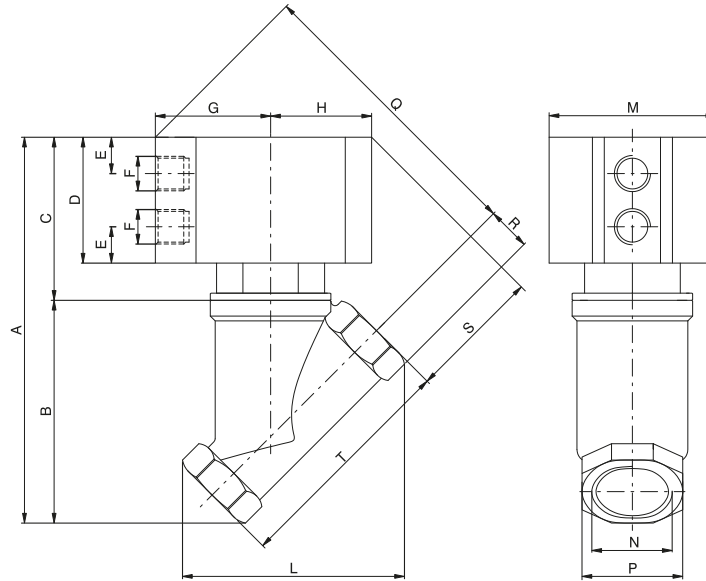

Ordering code	
<b>PVA.B.A.P.Y.C.S</b>	
ACTING	
<b>A</b>	DE=Double acting
	SC=Normally closed
	SA=Normally OPEN
PISTON	
<b>P</b>	N=Non magnetic
	M= Magnetic
CONNECTIONS	
<b>C</b>	A=G1/4"
	B=G3/8"
	C=G1/2"
	D=G3/4"
	E=G1"
	F=G1 1/4"
	G=G1 1/2"
	H=G2"
SEALS	
<b>S</b>	N=NBR
	V=FPM
	F=PTFE

TABLE OF DIMENSIONS

Connection (N)	Non magnetic version			Magnetic version			TECHNICAL DATA													
	A	C	D	A	C	D	B	E	F	G	H	L	M	P	Actuator (Ø)	Nominal Valve (Ø)	Weight (gr.)			
G1/4"	93,5	77,5	41	97,5	81,5	45	16	10,25	G1/8"	32,5	28,5	64	47	25	Ø40	Ø13,5	350			
G3/8"	93,5	77,5	41	97,5	81,5	45	16	10,25	G1/8"	32,5	28,5	64	47	25	Ø40	Ø13,5	350			
G1/2"	93,5	78	41	99,5	82	45	17,5	10,25	G1/8"	32,5	28,5	68	47	30	Ø40	Ø15	400			
G 3/4"	105	83	41	113	90	48	22	11,25	G1/8"	44	40	79	70	36	Ø63	Ø20,5	850			
G1"	117	89	41	125	101	53	28	11,25	G1/8"	44	40	94	70	44	Ø63	Ø25	1100			
G1 1/4"	131	103	48	136	108	53	28	11,25	G1/8"	44	40	110	70	55	Ø63	Ø30	1400			
G1 1/2"	154	118	57	166	130	69	36	13,75	G1/8"	56	49	120	90	60	Ø80	Ø38	2100			
G2"	169	124	57	181	136	69	45	13,75	G1/8"	56	49	140	90	73	Ø80	Ø49,5	3000			

Pad valves, 2-ways, are a reliable and economic solution to control fluid. Pneumatically actuated by a compact double or single acting cylinder with 360° revolving connections. Standard seals in contact with fluid are made in NBR, FPM or PTFE. The barrel profile allows the use of Pneumax magnetic sensors series 1500 (see the Sensors Section).

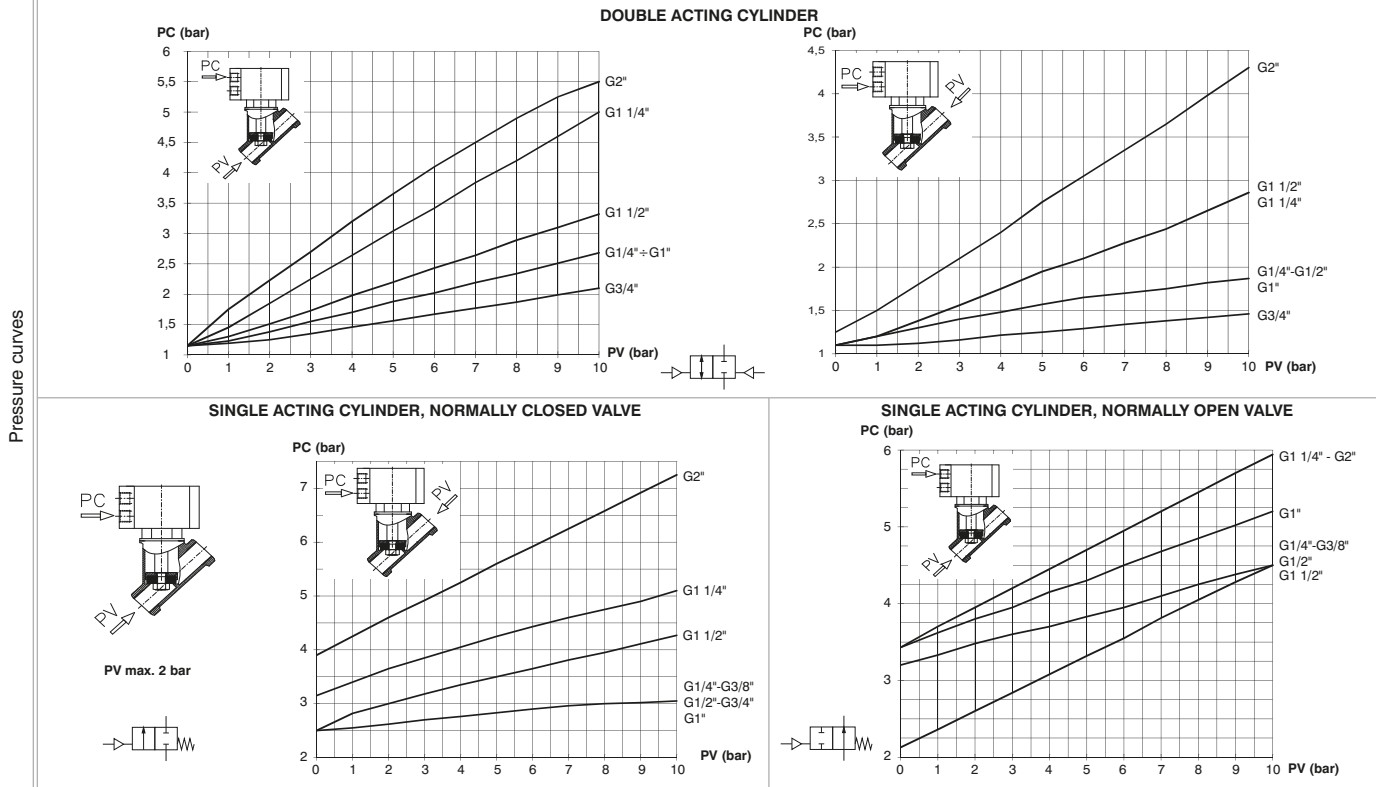

Operational characteristics

- Rear eye, Piston and Rod bushing = Anodized aluminium
- Cylinder = Aluminium alloy Anodized
- Spring = Zinc plated steel
- Seals = NBR, FPM, PTFE
- Piston rod = Chromed stainless steel
- Bushing, Bushing pad, Nut pad = Brass

Technical characteristics

Fluid	Filtered air.
Maximum working pressure (bar) 10	No lubrication needed, if applied it shall be continuous.
Temperature °C (non magnetic piston, NBR seals) -5 / +70	10
Temperature °C (non magnetic piston, FPM seals) -5 / +150	-10 / +70
Temperature °C (non magnetic piston, PTFE seals) -5 / +150	-10 / +150
Temperature °C (magnetic piston, NBR, FPM, PTFE seals)	-10 / +150
	-10 / +70



1

AIR DISTRIBUTION

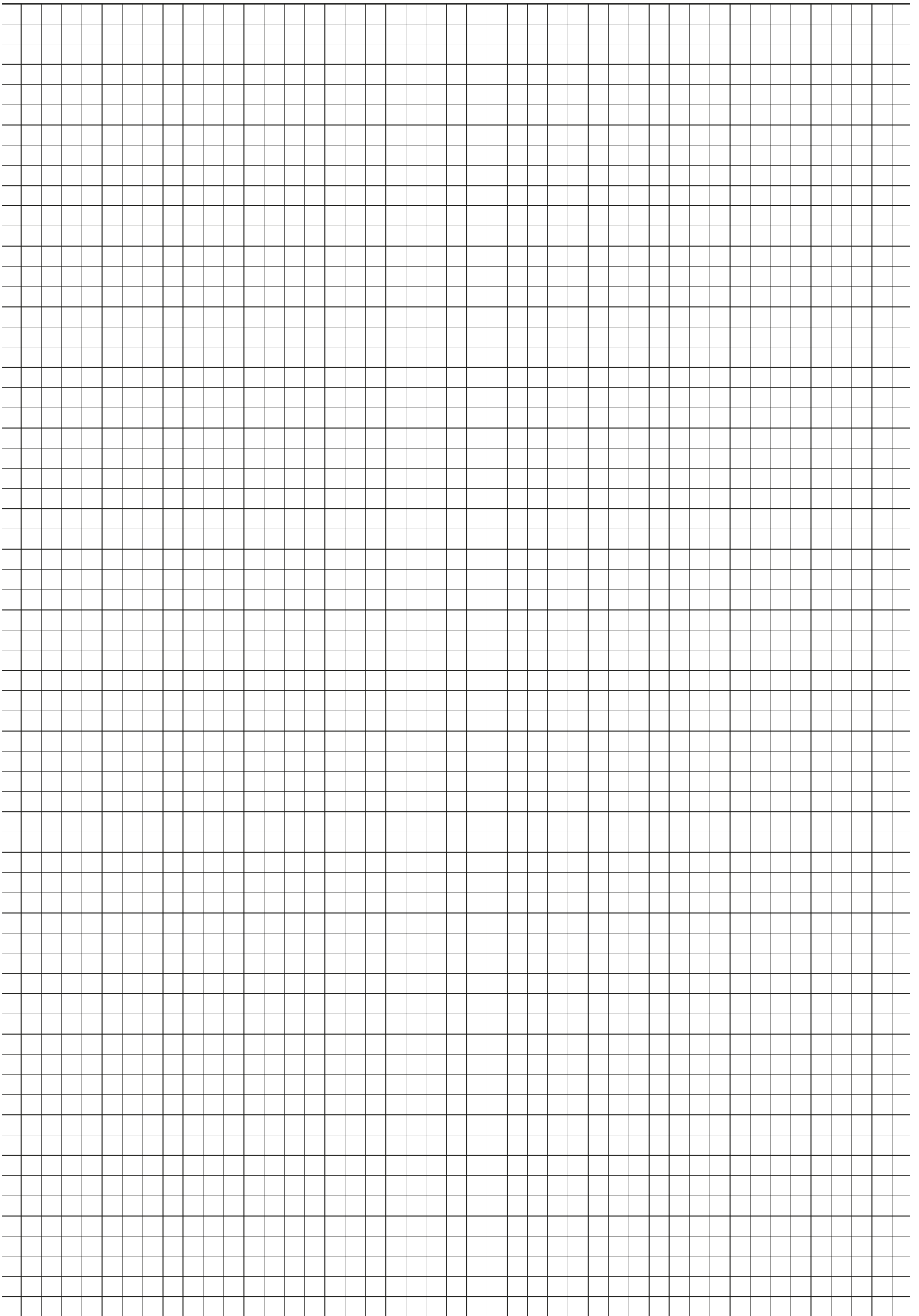



## F300 Series, Solenoid valves for fluids

### General details

**PNEUMAX** offer a vast range of solenoid valves in brass and stainless steel designed to control air, water, steam and all fluids that are compatible with the materials (body and seals) used in the range. The solenoid valves are 2 or 3-way, normally closed, normally open, general service, direct acting or servo-actuated, with connections available in NPT & BSP threads from G1/8" up to G2", with a working pressure range from vacuum to 100 bar. Solenoid valves are available with coils that conform to CESI 03 ATEX 344 certification for explosive environments. Our technical office ensures the highest standard of skill and understanding for the widest variety of applications, ensuring that the best possible solutions are found.

### Versions manufactured

**Direct action 2-way:** 2-way solenoid valves have an input connection and an output connection machined in the valve body, the orifice being intercepted by the plunger mounted in the core tube.

They can be **normally closed (2/2 NC)**, in this case the fluid is intercepted by the plunger at rest, with electricity applied, the input orifice is opened and the media reaches the intended use.

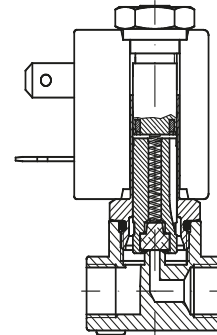

They can be **normally open (2/2 NO)**, in this case at rest the orifice remains open without electricity applied, the media reaches the intended use. When electricity is applied the input orifice closes.

Performance in both cases depends solely on the magnetic field produced by the solenoid coil.  
The solenoid valves can also work at zero pressure.

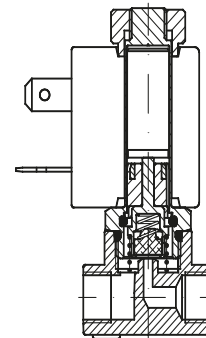

**Direct action 3-way:** 3-way solenoid valves have an input and an output connection in the valve body and an exhaust connection fitted in the fixed core. The input and exhaust orifices are intercepted directly by the plunger fitted within the core tube.

They can be **normally closed (3/2 NC)** and in this case, at rest, the incoming fluid is intercepted by the plunger and output port in connected to the exhaust port.  
Applying electrical power, the input orifice is opened and feed is supplied to the output. Exhaust is closed.

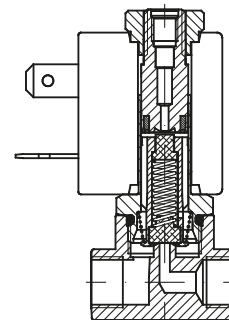

They can be **normally open (3/2 NA)** and in this case, at rest, the input orifice is open without electricity applied, the media reaches the intended use. Exhaust is closed.  
Applying power, the input orifice closes and the output discharges through the exhaust port.

Performance in both cases depends solely on the magnetic field produced by the solenoid coil.  
The solenoid valves can also work at zero pressure.

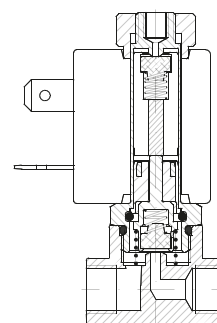

**Servo actuated**

With large-sized passage orifices, the static pressure value that needs to be overcome by the magnetic field produced by the coil increases.

These solenoid valves are used to control high-pressure values with large diameter bores. In these models, the fluid helps in the opening or closing of the main plunger.

They can be normally closed (2/2 NC) and have an input and a utilisation connection machined into the valve body and at rest the fluid is intercepted by the main plunger, which can be either diaphragm or a piston. In this condition, the fluid acts on both faces of the main plunger through a pinhole contributing to closure of the plunger.

Applying electrical power, the secondary, or pilot, orifice opens leading to the exhaust of the fluid, which acts to close the main plunger. Greater force is thus applied when opening, the plunger is raised from the orifice and allows the media to flow to the output.

In these versions, performance does not depend solely on the magnetic field produced by the coil; a minimum input pressure is also needed so as to move the diaphragm or the piston overcoming its rigidity and to keep it raised from the main orifice. ( $\Delta p$  minimum performance).

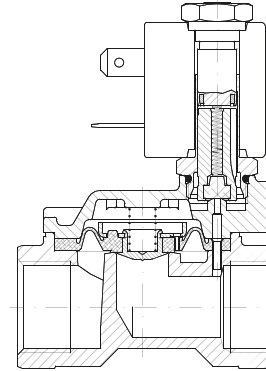

They can be **normally open (2/2 NA)**, and have an input and output connection machined into the valve body, and at rest the secondary plunger communicates with output, a minimum-pressure difference between the feed and the output causes the main shutter to rise, leading to it opening.

Applying electrical power, the secondary orifice closes and equilibrium between the pressure on the two faces of the main shutter is reinstated, and so it returns to its closed position on the main orifice.

In this version a minimum working pressure is also needed.

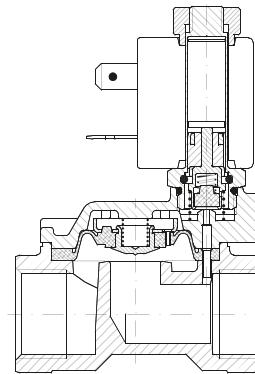

**Sealing materials**

Designation	Trade names	General characteristics	Field of use
FPM (Fluorocarbon)	VITON TECNOFLO FLUOREL	A synthetic hexa-fluoropropylene-based elastomer. Excellent resistance to high temperatures. Excellent resistance to ozone, oxygen, mineral oils, hydrocarbons and many chemical products. Not specific for superheated steam.	For general use up to 130 °C

1 AIR DISTRIBUTION



### Resistance to fluids

The table below serves to general information relating to the compatibility between FPM (fluorocarbon) and a number of neutral fluids. Where there are corrosive fluids, in order to establish compatibility, it is important to be aware of all the data relating to use: temperature, concentration and composition of the fluid.

Fluido	
Ethyl acetate	Non Compatible
Acetylene	Compatible
Vinegar	Non Compatible
Acetone	Non Compatible
Calcareous water	Compatible
Hot water <75°C	Compatible
Hot water and steam <140°C	Non Compatible
Water with glycol	Compatible
Deionised water	Compatible
Demineralised water	Compatible
Hydrogen peroxide	Compatible
Soapy water	Compatible
Carbon dioxide (liquid)	Non Compatible
Dry carbon dioxide (gas)	Compatible
Argon	Compatible
Nitrogen	Compatible
Petrol/Gasoline	Compatible
Benzol	Non Compatible
Butane	Compatible
Chloroform	Non Compatible
Ethyl Chloride	Compatible
Methyl chloride	Non Compatible
Helium	Compatible
Heptane	Compatible
Hexane	Compatible
Ethane	Compatible
Ethanol	Non Compatible
Formaldehyde	Compatible
Freon	Non Compatible
Natural gas	Compatible
Diesel oil	Compatible
Glycerine	Compatible
Ethylene glycol	Compatible
Hydrogen	Compatible
Isobutane	Compatible
Isopentane	Compatible
Methane	Compatible
Methanol	Non Compatible
Calcium monoxide	Compatible
Neon	Compatible
Nitrobenzene	Non Compatible
Mineral oil	Compatible
Oxygen	Compatible
Pentane-n	Compatible
Propanol-n	Compatible
Propane-n	Compatible
Carbon sulphide	Non Compatible
Toluene	Compatible
Dry trichloroethylene	Compatible
Xylene	Compatible

▶ 2-way solenoid normally closed valve, direct plunger operation

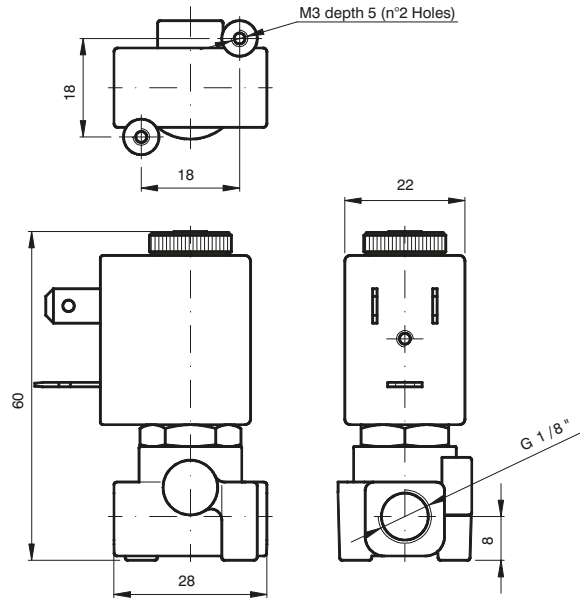

CODE	Connection G ISO 228	Orifice (mm)	KV (m <sup>3</sup> /h)	Differential pressure (bar)				Power Consumption			Coil Ⓢ		Temp. range (°C)
				Min	Max		AC Inrush	VA Holding	DC Watt	Series	Size		
					AC	DC							
F3105AV25Ⓢ	1/8"	2,5	0,14	0	8	5,5	12	8	6,5	MI	22	-10 +130	

N.B. For use with steam, maximum admitted pressure PS is 6 bar (relative pressure) with seals in FPM  
Esempio: F3105AV25Ⓢ => F3105AV25MI58:

2-way normally closed, direct acting solenoid valve with G connector (ISO228) 1/8", Seals in FPM, Orifice 2,5 mm, Coil 220V 50/60Hz (MI58, size 22).

Pneumatic symbol

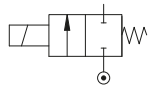

Diagram

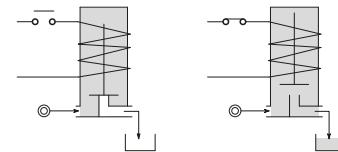

**Operational characteristic**

- Brass Body
- Guide pipe in Brass
- Mobile and fixed core in Stainless Steel
- Springs in Stainless Steel
- Sealing assemblies in FPM

**- OPTIONS (if requested):**

- Manual operation
- Surface treatment in chemical nickel-plating
- Guide pipe in Stainless Steel
- For use with oxygen

**Technical characteristic**

Maximum admitted pressure (bar)	50
Maximum fluid viscosity (mm <sup>2</sup> /s)	25cSt
Ambient temperature: with class F coil (°C)	-10 +55
Mounting position	indifferent
Weight (gr.) with MI Series Coil	130

► 2-way solenoid normally closed valve, direct plunger operation

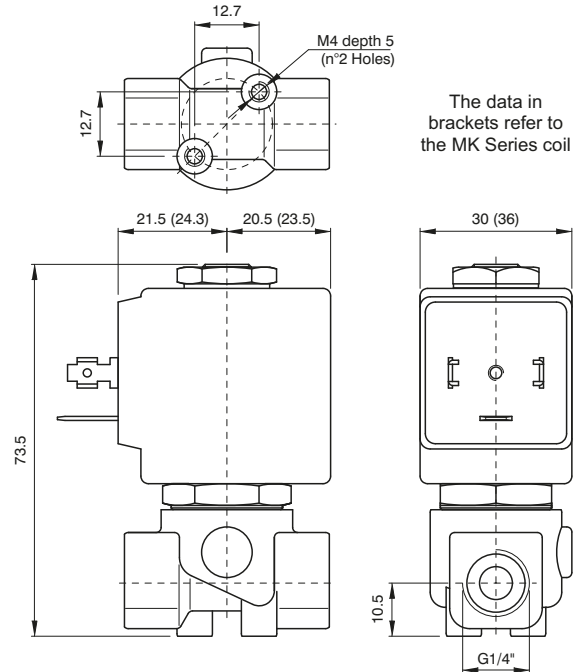

1  
AIR DISTRIBUTION

CODE "V" = Seals in FPM "E" = Coil	Connection G ISO 228	Orifice (mm)	KV (m³/h)	Differential pressure (bar)			Power Consumption			Coil E		Temp. range (°C)
				Min	Max		AC Inrush	VA Holding	DC Watt	Series	Size	
					AC	DC						
F3106BV15E	1/4"	1,5	0,07	0	30	26	20	15	10	MG	30	-10 +140
F3106BV20E	1/4"	2,0	0,1	0	22	20	20	15	10	MG	30	
F3106BV25E	1/4"	2,5	0,15	0	16	14	20	15	10	MG	30	
F3106BV35E	1/4"	3,5	0,32	0	10	8	20	15	10	MG	30	
F3106BV45E	1/4"	4,5	0,41	0	6,5	3,5	20	15	10	MG	30	
F3106BV52E	1/4"	5,2	0,47	0	4	1,8	20	15	10	MG	30	
F3106BV64E	1/4"	6,4	0,64	0	3	1	20	15	10	MG	30	
F3106BV15E	1/4"	1,5	0,07	0	80	80	40	30	27	MK	36	
F3106BV20E	1/4"	2,0	0,1	0	50	40	40	30	27	MK	36	
F3106BV25E	1/4"	2,5	0,15	0	35	33	40	30	27	MK	36	
F3106BV35E	1/4"	3,5	0,32	0	20	19	40	30	27	MK	36	
F3106BV45E	1/4"	4,5	0,41	0	14	13	40	30	27	MK	36	
F3106BV52E	1/4"	5,2	0,47	0	10	9	40	30	27	MK	36	
F3106BV64E	1/4"	6,4	0,64	0	5	4,5	40	30	27	MK	36	

N.B. For use with steam, maximum admitted pressure PS is 6 bar (relative pressure) with seals in PTFE and 2.5 bar with seals in EPDM.  
Example: F3106BV52E => F3106BV52MG58:  
2-way normally closed, direct acting solenoid valve with G connector (ISO228) 1/4", Seals in FPM, Orifice 5.2 mm, Coil 220V 50/60Hz (MG58, size 30).

Pneumatic symbol		Diagram															
<b>Operational characteristic</b>		<b>Technical characteristic</b>															
<ul style="list-style-type: none"> <li>- Brass Body</li> <li>- Guide pipe in Stainless Steel</li> <li>- Mobile and fixed core in Stainless Steel</li> <li>- Springs in Stainless Steel</li> <li>- Sealing assemblies in FPM</li> <li>- <b>OPTIONS (if requested):</b> <ul style="list-style-type: none"> <li>- Manual operation</li> <li>- Surface treatment in chemical nickel-plating</li> <li>- Inserted stainless steel seating</li> <li>- For use with oxygen</li> </ul> </li> </ul>		<table border="1"> <tr><td>Maximum admitted pressure (bar)</td><td>80</td></tr> <tr><td>Maximum fluid viscosity (mm<sup>2</sup>/s)</td><td>25cSt</td></tr> <tr><td>Ambient temperature: with class F coil (°C)</td><td>-10 +55</td></tr> <tr><td>Ambient temperature: with class H coil (°C)</td><td>-10 +80</td></tr> <tr><td>Mounting position</td><td>indifferent</td></tr> <tr><td>Weight (gr.) with MG Series Coil</td><td>300</td></tr> <tr><td>Weight (gr.) with MK Series Coil</td><td>380</td></tr> </table>		Maximum admitted pressure (bar)	80	Maximum fluid viscosity (mm <sup>2</sup> /s)	25cSt	Ambient temperature: with class F coil (°C)	-10 +55	Ambient temperature: with class H coil (°C)	-10 +80	Mounting position	indifferent	Weight (gr.) with MG Series Coil	300	Weight (gr.) with MK Series Coil	380
Maximum admitted pressure (bar)	80																
Maximum fluid viscosity (mm <sup>2</sup> /s)	25cSt																
Ambient temperature: with class F coil (°C)	-10 +55																
Ambient temperature: with class H coil (°C)	-10 +80																
Mounting position	indifferent																
Weight (gr.) with MG Series Coil	300																
Weight (gr.) with MK Series Coil	380																

2-way solenoid normally closed valve, direct plunger operation

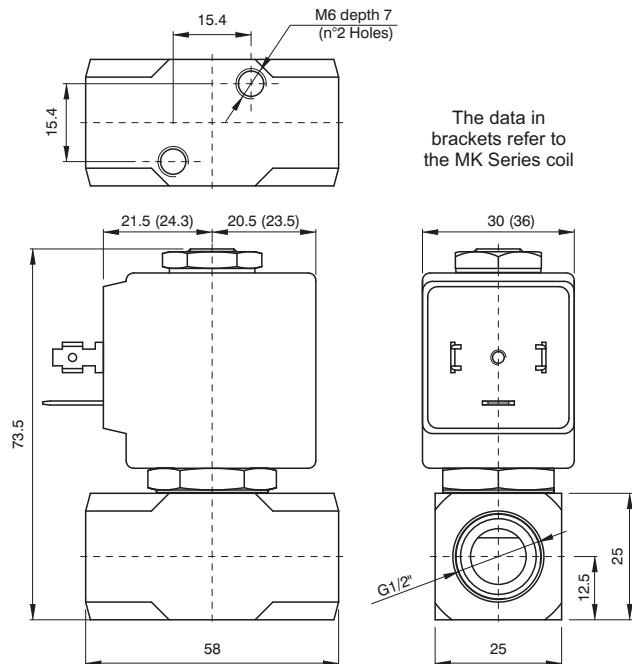

The data in brackets refer to the MK Series coil

CODE "V"=Seals in FPM ⊕ = Coil	Connection G ISO 228	Orifice (mm)	KV (m³/h)	Differential pressure (bar)			Power Consumption			Coil ⊕		Temp. range (°C)
				Min	Max		AC Inrush	VA Holding	DC Watt	Series	Size	
					AC	DC						
F3106DV45⊕	1/2"	4,5	0,41	0	6,5	3,5	20	15	10	MG	30	-10 +140
F3106DV52⊕	1/2"	5,2	0,47	0	4	1,8	20	15	10	MG	30	
F3106DV64⊕	1/2"	6,4	0,64	0	3	1	20	15	10	MG	30	
F3106DV45⊕	1/2"	4,5	0,41	0	14	13	40	30	27	MK	36	
F3106DV52⊕	1/2"	5,2	0,47	0	10	9	40	30	27	MK	36	
F3106DV64⊕	1/2"	6,4	0,64	0	5	4,5	40	30	27	MK	36	

N.B. For use with steam, maximum admitted pressure PS is 6 bar (relative pressure) with seals in PTFE and 2.5 bar with seals in EPDM.

Example: F3106DV52⊕ => F3106DV52MK5:

2-way normally closed, direct acting solenoid valve with G connector (ISO228) 1/2", Seals in FPM, Orifice 5.2 mm, Coil 24V DC (MK5, size 36).

Pneumatic symbol

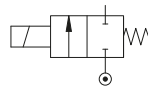

Diagram

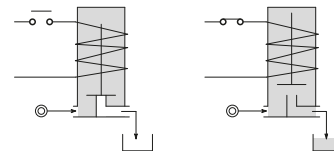

Operational characteristic

- Brass Body
- Guide pipe in Stainless Steel
- Mobile and fixed core in Stainless Steel
- Springs in Stainless Steel
- Sealing assemblies in FPM

- OPTIONS (if requested):

- Manual operation
- Surface treatment in chemical nickel-plating
- For use with oxygen

Technical characteristic

Maximum admitted pressure (bar)	80
Maximum fluid viscosity (mm <sup>2</sup> /s)	25cSt
Ambient temperature: with class F coil (°C)	-10 +55
Ambient temperature: with class H coil (°C)	-10 +80
Mounting position	indifferent
Weight (gr.) with MG Series Coil	300
Weight (gr.) with MK Series Coil	380

► 2-Way normally closed solenoid valve, servo-actuated diaphragm

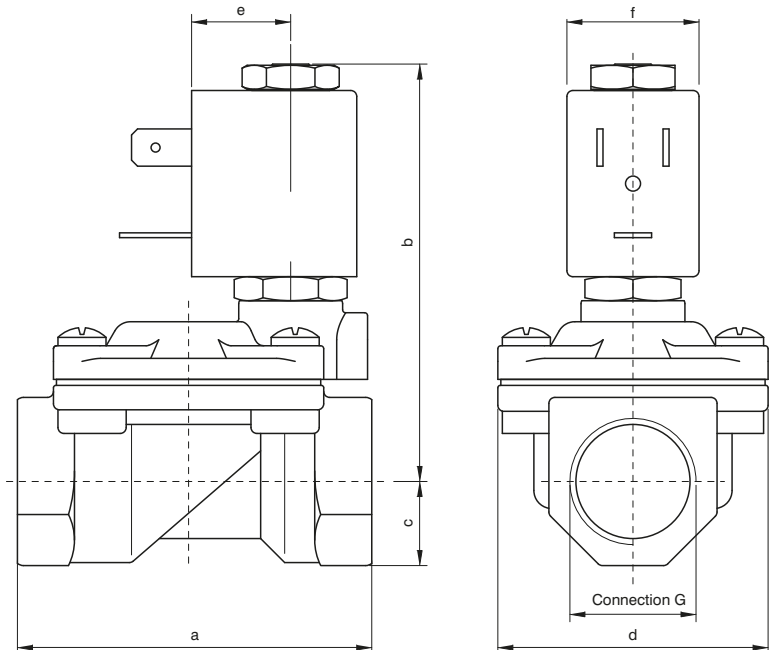

Connection	a	b	c	d	e	f	Weight (g)
G1/4" Ø10	49	65	11	32	16	22	230
G3/8" Ø12	59	70	14	45	16	22	420
G1/2" Ø12	59	70	14	45	16	22	390
G3/4"	79	76	18	55	16	22	650
G1"	96	85	20	72	16	22	1050
G1" 1/4	119	92	25	85	16	22	1700

CODE "V" = Seals in FPM ⊕ = Coil	Connection G ISO 228	Orifice (mm)	KV (m³/h)	Differential pressure (bar)			Power Consumption			Coil ⊕		Temp. range (°C)
				Min	Max		AC Inrush	VA Holding	DC Watt	Series	Size	
					AC	DC						
F3107BV10⊕	1/4"	10	1,5	0,15	15	15	12	8	6,5	MI	22	-10 +140
F3107CV12⊕	3/8"	12	2,2	0,15	15	15	12	8	6,5	MI	22	
F3107DV12⊕	1/2"	12	2,5	0,15	15	15	12	8	6,5	MI	22	
F3107EV18⊕	3/4"	18	5,5	0,15	13	13	12	8	6,5	MI	22	
F3107FV25⊕	1"	24	10,2	0,15	10	10	12	8	6,5	MI	22	
F3107GV30⊕	1" 1/4	30	15	0,15	10	10	12	8	6,5	MI	22	

N.B. For use with steam maximum admitted pressure PS is 2.5 bar (relative pressure)

Example: F3107BV10⊕ => F3107BV10MI5:

2-Way normally closed solenoid valve, servo-actuated diaphragm with Connector G (ISO228) 1/4", Seals in FPM, Orifice 10 mm, Coil 24V DC (MI5, size 22).

Pneumatic symbol

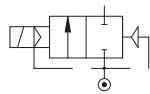

Diagram

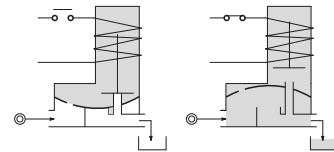

**Operational characteristic**

- Body and cover in Brass
- Guide pipe in Stainless Steel
- Mobile and fixed core in Stainless Steel
- Springs in Stainless Steel
- Sealing assemblies in FPM

**- OPTIONS (if requested):**

- Manual operation
- Surface treatment in chemical nickel-plating
- Coil for potentially explosive environments meeting 'ATEX standards Ex m Serie XME'.
- Version with slowed commutation
- Version for vacuum (air/gas)
- Version for use with oxygen
- "SVGW/SSIGE" approved versions.

**Technical characteristic**

Minimum differential pressure (bar)	0,15
Maximum admitted pressure (bar)	25
Maximum fluid viscosity (mm <sup>2</sup> /s)	25cSt
Ambient temperature: with class F coil (°C)	-10 +55
Ambient temperature: with class H coil (°C)	-10 +80
Mounting position	Preferably with coil upwards

2-Way normally closed solenoid valve, servo-actuated diaphragm

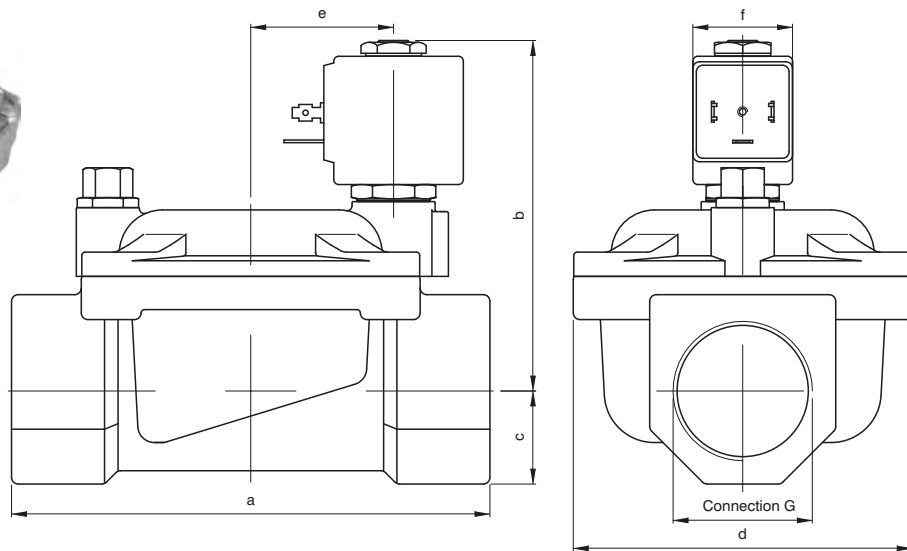

Connection	a	b	c	d	e	f	Weight (g)
G1" 1/4	142	105	28	102	21	30	3000
G1" 1/2	142	105	28	102	21	30	2850
G2"	158	115	35	119	21	30	4300

CODE "V"=Seals in FPM "C" = Coil	Connection G ISO 228	Orifice (mm)	KV (m <sup>3</sup> /h)	Differential pressure (bar)			Power Consumption			Coil "C"		Temp. range (°C)
				Min	Max		AC Inrush	VA Holding	DC Watt	Series	Size	
					AC	DC						
F3107GV37C	1 1/4"	37	18	0,15	10	10	20	15	10	MG	30	-10 +140
F3107HV37C	1" 1/2"	37	21	0,15	10	10	20	15	10	MG	30	
F3107IV50C	2"	50	36	0,15	10	10	20	15	10	MG	30	

N.B. For use with steam maximum admitted pressure PS is 2.5 bar (relative pressure)

Example: F3107GV37C => F3107GV37MG5:

2-Way normally closed solenoid valve, servo-actuated diaphragm with Connector G (ISO228) 1" 1/4", Seals in FPM, Orifice 37 mm, Coil 24V DC (MG5, size 30).

Pneumatic symbol

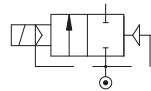

Diagram

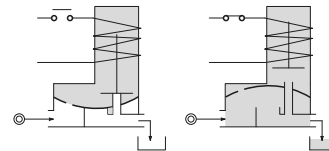

**Operational characteristic**

- Body and cover in Brass
- Guide pipe in Stainless Steel
- Mobile and fixed core in Stainless Steel
- Springs in Stainless Steel
- Sealing assemblies in FPM

**- OPTIONS (if requested):**

- Manual operation
- Surface treatment in chemical nickel-plating
- Version for vacuum (air/gas)

**Technical characteristic**

Minimum differential pressure (bar)	0,15 ÷ 3
Maximum admitted pressure (bar)	80
Maximum fluid viscosity (mm <sup>2</sup> /s)	25cSt
Ambient temperature: with class F coil (°C)	-10 +55
Ambient temperature: with class H coil (°C)	-10 +80
Mounting position	Preferably with coil upwards





► 2-way solenoid normally closed valve, direct plunger operation

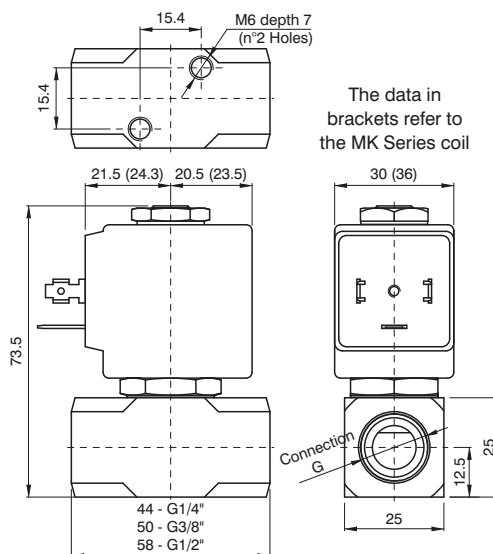

CODE "V"=Seals in FPM ⊕ = Coil	Connection G ISO 228	Orifice (mm)	KV (m³/h)	Differential pressure (bar)			Power Consumption			Coil ⊕		Temp. range (°C)
				Min	Max		AC Inrush	VA Holding	DC Watt	Series	Size	
					AC	DC						
F3110BV25⊕	1/4"	2,5	0,15	0	16	14	20	15	10	MG	30	-10 +140
F3110BV35⊕	1/4"	3,5	0,32	0	10	8	20	15	10	MG	30	
F3110BV45⊕	1/4"	4,5	0,41	0	6,5	3,5	20	15	10	MG	30	
F3110CV35⊕	3/8"	3,5	0,32	0	10	8	20	15	10	MG	30	
F3110CV52⊕	3/8"	5,2	0,47	0	4	1,8	20	15	10	MG	30	
F3110DV35⊕	1/2"	3,5	0,32	0	10	8	20	15	10	MG	30	
F3110DV52⊕	1/2"	5,2	0,47	0	4	1,8	20	15	10	MG	30	
F3110DV64⊕	1/2"	6,4	0,64	0	3,5	1	20	15	10	MG	30	
F3110BV25⊕	1/4"	2,5	0,15	0	35	33	40	30	27	MK	36	
F3110BV35⊕	1/4"	3,5	0,32	0	20	19	40	30	27	MK	36	
F3110BV45⊕	1/4"	4,5	0,41	0	14	13	40	30	27	MK	36	
F3110CV35⊕	3/8"	3,5	0,32	0	20	19	40	30	27	MK	36	
F3110CV52⊕	3/8"	5,2	0,47	0	10	9	40	30	27	MK	36	
F3110DV35⊕	1/2"	3,5	0,32	0	20	19	40	30	27	MK	36	
F3110DV52⊕	1/2"	5,2	0,47	0	10	9	40	30	27	MK	36	
F3110DV64⊕	1/2"	6,4	0,64	0	5	4,5	40	30	27	MK	36	

N.B. For use with steam, maximum admitted pressure PS is 6 bar (relative pressure)  
Example: F3110BV25⊕ => F3110BV25MG5:  
2-way solenoid normally closed valve, direct plunger operation with Connector G (ISO228) 1/4", Seals in FPM, Orifice 2,5 mm, Coil 24V DC (MG5, size 30).

Pneumatic symbol

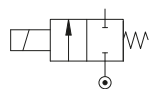

Diagram

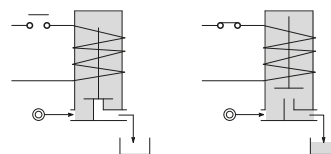

**Operational characteristic**

- Stainless Steel Body
- Guide pipe in Stainless Steel
- Mobile and fixed core in Stainless Steel
- Springs in Stainless Steel
- Sealing assemblies in FPM

**- OPTIONS (if requested):**

- Manual operation
- Advance ring in silver
- For use with oxygen

**Technical characteristic**

Maximum admitted pressure (bar)	100
Maximum fluid viscosity (mm <sup>2</sup> /s)	25cSt
Ambient temperature: with class F coil (°C)	-10 +55
Ambient temperature: with class H coil (°C)	-10 +80
Mounting position	indifferent
Weight (gr.) with MG Series Coil	360
Weight (gr.) with MK Series Coil	440

2-way solenoid normally closed valve, direct plunger operation

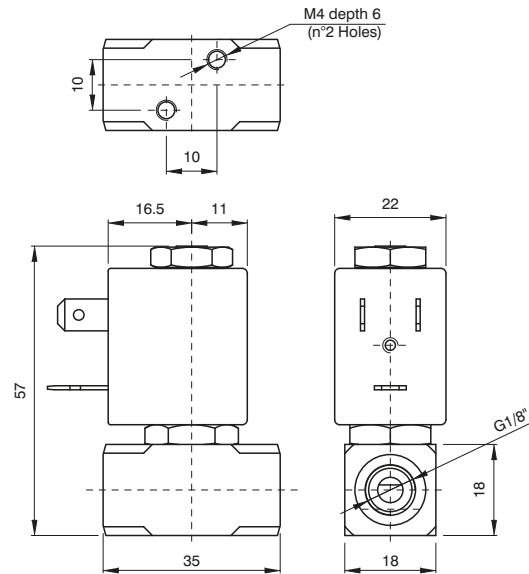

CODE "V" = Seals in FPM "E" = Coil	Connection G ISO 228	Orifice (mm)	KV (m³/h)	Differential pressure (bar)				Power Consumption			Coil "E"		Temp. range (°C)
				Min	Max		AC Inrush	VA Holding	DC Watt	Series	Size		
					AC	DC							
F3111AV12E	1/8"	1,2	0,04	0	25	25	12	8	6,5	MI	22	-10 +140	
F3111AV15E	1/8"	1,5	0,06	0	16	16	12	8	6,5	MI	22		
F3111AV20E	1/8"	2	0,09	0	12	10	12	8	6,5	MI	22		

N.B. For use with steam, maximum admitted pressure PS is 6 bar (relative pressure)

Example: F3111AV12E => F3111AV12MI56:

2-way solenoid normally closed valve, direct plunger operation with Connector G (ISO228) 1/8", Seals in FPM, Orifice 1,2 mm, Coil 24V 50/60Hz (MI56, size 22).

Pneumatic symbol

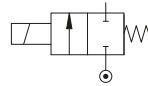

Diagram

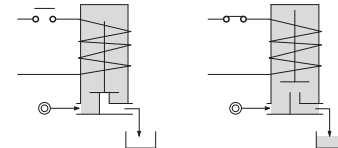

Operational characteristic

- Stainless Steel Body
- Guide pipe in Stainless Steel
- Mobile and fixed core in Stainless Steel
- Springs in Stainless Steel
- Sealing assemblies in FPM

- OPTIONS (if requested):

- Advance ring in silver
- Coil for potentially explosive environments meeting 'ATEX standards Ex m Serie XME':
- For use with oxygen

Technical characteristic

Maximum admitted pressure (bar)	50
Maximum fluid viscosity (mm <sup>2</sup> /s)	25cSt
Ambient temperature: with class F coil (°C)	-10 +55
Ambient temperature: with class H coil (°C)	-10 +80
Mounting position	indifferent
Weight (g.)	150

► 2-way normally closed diaphragm solenoid valve in stainless steel AISI 316, servo-actuated

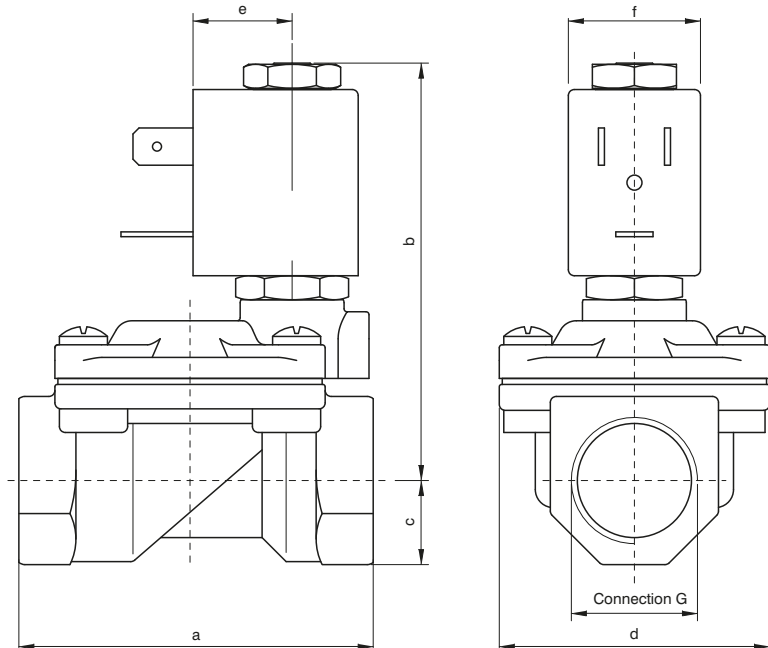

Connection	a	b	c	d	e	f	Weight (g)
G3/8"	59	70	11	45	16	22	300
G1/2"	59	70	13	45	16	22	320
G3/4"	80	75	16	55	16	22	550
G1"	100	84	20	72	16	22	950

CODE "V" = Seals in FPM ⊕ = Coil	Connection G ISO 228	Orifice (mm)	KV (m³/h)	Differential pressure (bar)			Power Consumption			Coil ⊕		Temp. range (°C)
				Min	Max		AC Inrush	VA Holding	DC Watt	Series	Size	
					AC	DC						
F3177CV12⊕	3/8"	12	2,2	0,15	15	15	12	8	6,5	MI	22	-10 +140
F3177DV12⊕	1/2"	12	2,5	0,15	15	15	12	8	6,5	MI	22	
F3177EV18⊕	3/4"	18	5,5	0,15	13	13	12	8	6,5	MI	22	
F3177FV25⊕	1"	24	10,2	0,15	10	10	12	8	6,5	MI	22	

N.B. For use with steam maximum admitted pressure PS is 2.5 bar (relative pressure)  
Example: F3177CV12⊕ => F3177CV12MI5:

2-way normally closed diaphragm solenoid valve in stainless steel AISI 316, servo-actuated with Connector G (ISO228) 3/8", Seals in FPM, Orifice 12 mm, Coil 24V DC (MI5, size 22).

Pneumatic symbol

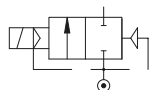

Diagram

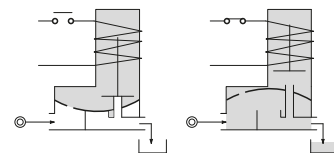

**Operational characteristic**

- Body and cover in Stainless Steel.
- Guide pipe in Stainless Steel
- Mobile and fixed core in Stainless Steel
- Springs in Stainless Steel
- Sealing assemblies in FPM

**- OPTIONS (if requested):**

- Manual operation
- Coil for potentially explosive environments meeting 'ATEX standards Ex m Serie XME'.
- Seals for use with foodstuff fluids.
- Version with slowed commutation
- Version for use with oxygen
- Advance ring in silver

**Technical characteristic**

Minimum differential pressure (bar)	0,15
Maximum admitted pressure (bar)	25
Maximum fluid viscosity (mm <sup>2</sup> /s)	25cSt
Ambient temperature: with class F coil (°C)	-10 +55
Ambient temperature: with class H coil (°C)	-10 +80
Mounting position	Preferably with coil upwards

► 2-way normally open with direct operated plunger solenoid valve

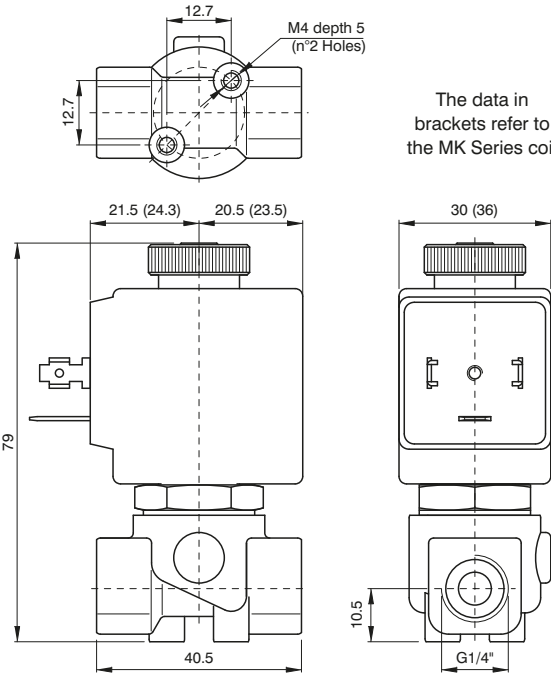

CODE "V"=Seals in FPM ⊕ = Coil	Connection G ISO 228	Orifice (mm)	KV (m³/h)	Differential pressure (bar)				Power Consumption			Coil ⊕		Temp. range (°C)
				Min	Max		AC Inrush	VA Holding	DC Watt	Series	Size		
					AC	DC							
F3206BV15⊕	1/4"	1,5	0,07	0	23	-	20	15	-	MG	30	-10 +140	
F3206BV20⊕	1/4"	2,0	0,1	0	17	-	20	15	-	MG	30		
F3206BV25⊕	1/4"	2,5	0,15	0	12	-	20	15	-	MG	30		
F3206BV35⊕	1/4"	3,5	0,32	0	7	-	20	15	-	MG	30		
F3206BV45⊕	1/4"	4,5	0,41	0	4,5	-	20	15	-	MG	30		
F3206BV52⊕	1/4"	5,2	0,47	0	3	-	20	15	-	MG	30		
F3206BV15⊕	1/4"	1,5	0,07	0	23	23	20	15	-	MK	36		
F3206BV20⊕	1/4"	2,0	0,1	0	17	17	40	30	27	MK	36		
F3206BV25⊕	1/4"	2,5	0,15	0	12	12	40	30	27	MK	36		
F3206BV35⊕	1/4"	3,5	0,32	0	7	7	40	30	27	MK	36		
F3206BV45⊕	1/4"	4,5	0,41	0	4,5	4,5	40	30	27	MK	36		
F3206BV52⊕	1/4"	5,2	0,47	0	3	3	40	30	27	MK	36		
F3206BV64⊕	1/4"	6,4	0,64	0	3,5	3,5	40	30	27	MK	36		

N.B. For use with steam maximum admitted pressure PS is 2.5 bar (relative pressure)

Example: F3206BV15⊕ => F3206BV15MG58:

2-way normally open with direct operated plunger solenoid valve with Connector G (ISO228) 1/4", Seals in FPM, Orifice 1,5 mm, Coil 220V 50/60Hz (MG58, size 30).

Pneumatic symbol

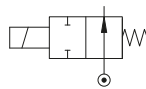

Diagram

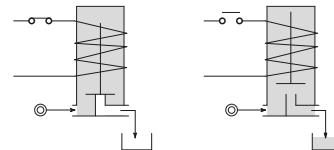

**Operational characteristic**

- Brass Body.
- Guide pipe in Brass.
- Mobile and fixed core in Stainless Steel
- Springs in Stainless Steel
- Sealing assemblies in FPM

**- OPTIONS (if requested):**

- Surface treatment in chemical nickel-plating
- Guide pipe in Stainless Steel

**Technical characteristic**

Maximum admitted pressure (bar)	50
Maximum fluid viscosity (mm <sup>2</sup> /s)	25cSt
Ambient temperature: with class F coil (°C)	-10 +55
Ambient temperature: with class H coil (°C)	-10 +80
Mounting position	indifferent
Weight (gr.) with MG Series Coil	300
Weight (gr.) with MK Series Coil	380

► 2-way normally open with direct operated plunger solenoid valve

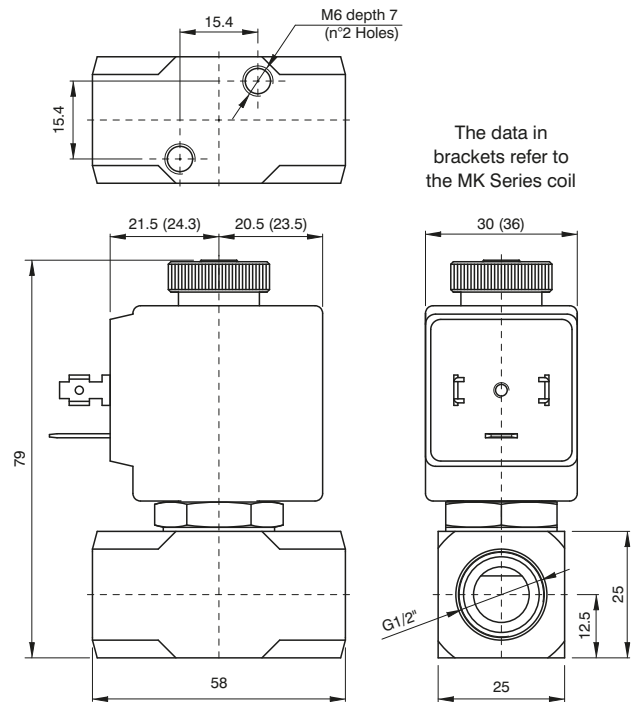

CODE "V"=Seals in FPM ⊕ = Coil	Connection G ISO 228	Orifice (mm)	KV (m³/h)	Differential pressure (bar)			Power Consumption			Coil ⊕		Temp. range (°C)
				Min	Max		AC Inrush	VA Holding	DC Watt	Series	Size	
					AC	DC						
F3206DV52⊕	1/2"	5,2	0,47	0	3	-	20	15	-	MG	30	-10 +140
F3206DV52⊕	1/2"	5,2	0,47	0	3	3	40	30	27	MK	36	
F3206DV64⊕	1/2"	6,4	0,64	0	3,5	3,5	40	30	27	MK	36	

N.B. For use with steam maximum admitted pressure PS is 2.5 bar (relative pressure)

Example: F3206DV30⊕ => F3206DV30MG58:

2-way normally open with direct operated plunger solenoid valve with Connector G (ISO228) 1/2", Seals in FPM, Orifice 3 mm, Coil) 220V 50/60Hz (MG58, size 30).

Pneumatic symbol

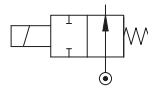

Diagram

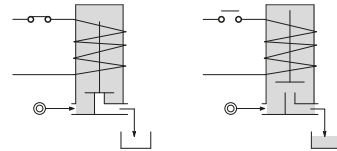

**Operational characteristic**

- Brass Body.
- Guide pipe in Brass.
- Mobile and fixed core in Stainless Steel
- Springs in Stainless Steel
- Sealing assemblies in FPM

**- OPTIONS (if requested):**

- Surface treatment in chemical nickel-plating
- Guide pipe in Stainless Steel

**Technical characteristic**

Maximum admitted pressure (bar)	50
Maximum fluid viscosity (mm <sup>2</sup> /s)	25cSt
Ambient temperature: with class F coil (°C)	-10 +55
Ambient temperature: with class H coil (°C)	-10 +80
Mounting position	indifferent
Weight (gr.) with MG Series Coil	360
Weight (gr.) with MK Series Coil	440

▶ 2-way normally open servo-actuated diaphragm solenoid valve

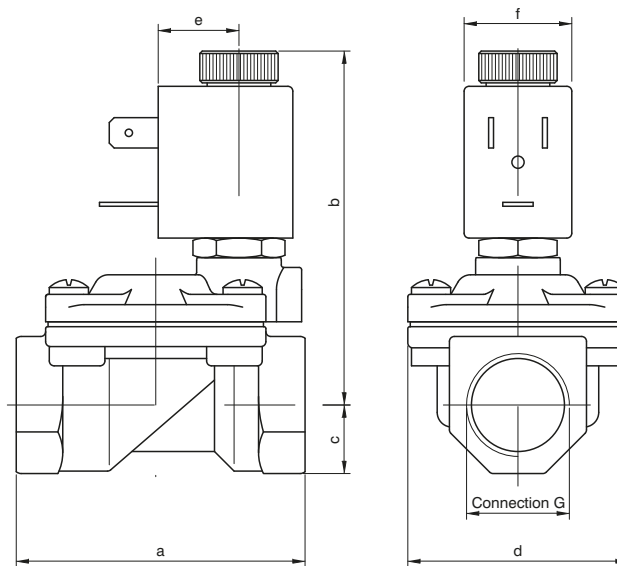

Connection	a	b	c	d	e	f	Weight (g)
G1/4" Ø10	49	69	11	32	16	22	230
G3/8" Ø10	49	69	11	32	16	22	240
G1/2" Ø12	59	74	14	45	16	22	390
G3/4"	79	81	18	55	16	22	650
G1"	96	89	20	72	16	22	1050

CODE "V"=Seals in FPM ⊕ = Coil	Connection G ISO 228	Orifice (mm)	KV (m³/h)	Differential pressure (bar)			Power Consumption			Coil ⊕		Temp. range (°C)
				Min	Max		AC Inrush	VA Holding	DC Watt	Series	Size	
					AC	DC						
F3207BV10⊕	1/4"	10	1,5	0,15	15	15	12	8	6,5	MI	22	-10 +140
F3207CV10⊕	3/8"	10	1,7	0,15	15	15	12	8	6,5	MI	22	
F3207DV12⊕	1/2"	12	2,5	0,15	15	15	12	8	6,5	MI	22	
F3207EV18⊕	3/4"	18	5,5	0,15	13	13	12	8	6,5	MI	22	
F3207FV25⊕	1"	24	10,2	0,15	10	10	12	8	6,5	MI	22	

N.B. For use with steam maximum admitted pressure PS is 2.5 bar (relative pressure)

Example: F3207BV10⊕ => F3207BV10MI5.

2-way normally open servo-actuated diaphragm solenoid valve with Connector G (ISO228) 1/4", Seals in FPM, Orifice 10 mm, Coil 24V DC (MI5, size 22).

Pneumatic symbol

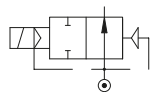

Diagram

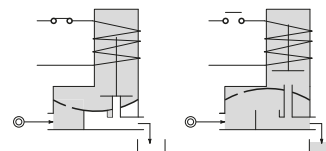

**Operational characteristic**

- Body and cover in Brass
- Guide pipe in Stainless Steel
- Mobile and fixed core in Stainless Steel
- Springs in Stainless Steel
- Sealing assemblies in FPM

**- OPTIONS (if requested):**

- Surface treatment in chemical nickel-plating
- Coil for potentially explosive environments meeting 'ATEX standards Ex m Serie XME'.

**Technical characteristic**

Minimum differential pressure (bar)	0,15
Maximum admitted pressure (bar)	25
Maximum fluid viscosity (mm <sup>2</sup> /s)	25cSt
Ambient temperature: with class F coil (°C)	-10 +55
Ambient temperature: with class H coil (°C)	-10 +80
Mounting position	indifferent



2-way normally open with direct operated plunger solenoid valve

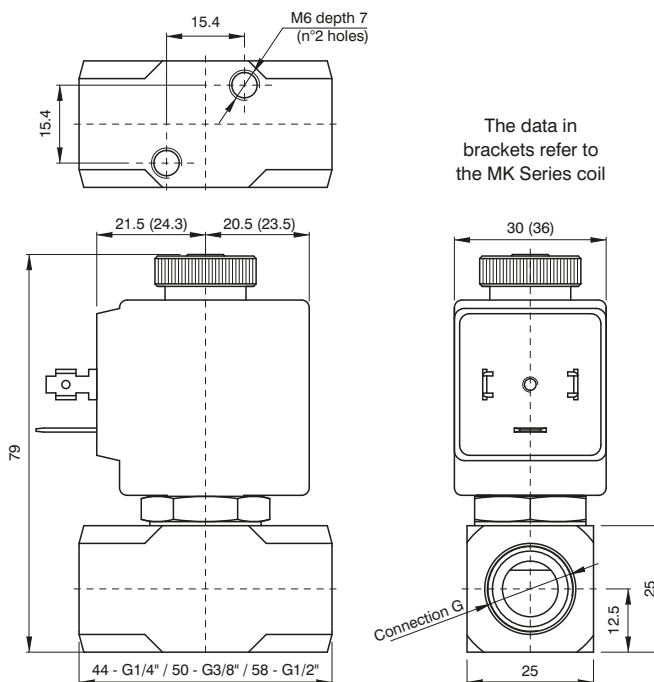

CODE "V" = Seals in FPM ⊕ = Coil	Connection G ISO 228	Orifice (mm)	KV (m³/h)	Differential pressure (bar)			Power Consumption			Coil ⊕		Temp. range (°C)
				Min	Max		AC Inrush	VA Holding	DC Watt	Series	Size	
					AC	DC						
F3210BV25⊕	1/4"	2,5	0,15	0	10	-	20	15	-	MG	30	-10 +140
F3210BV35⊕	1/4"	3,5	0,32	0	7	-	20	15	-	MG	30	
F3210BV45⊕	1/4"	4,5	0,41	0	4,5	-	20	15	-	MG	30	
F3210CV35⊕	3/8"	3,5	0,32	0	7	-	20	15	-	MG	30	
F3210CV52⊕	3/8"	5,2	0,47	0	3	-	20	15	-	MG	30	
F3210DV35⊕	1/2"	3,5	0,32	0	7	-	20	15	-	MG	30	
F3210DV52⊕	1/2"	5,2	0,47	0	3	-	20	15	-	MG	30	
F3210BV25⊕	1/4"	2,5	0,15	0	10	10	40	30	27	MK	36	
F3210BV35⊕	1/4"	3,5	0,32	0	7	7	40	30	27	MK	36	
F3210BV45⊕	1/4"	4,5	0,41	0	4,5	4,5	40	30	27	MK	36	
F3210CV35⊕	3/8"	3,5	0,32	0	7	7	40	30	27	MK	36	
F3210CV52⊕	3/8"	5,2	0,47	0	3	3	40	30	27	MK	36	
F3210DV35⊕	1/2"	3,5	0,32	0	7	7	40	30	27	MK	36	
F3210DV52⊕	1/2"	5,2	0,47	0	3	3	40	30	27	MK	36	
F3210DV64⊕	1/2"	6,4	0,64	0	3,5	3,5	40	30	27	MK	36	

N.B. For use with steam maximum admitted pressure PS is 2.5 bar (relative pressure)  
Example: F3210BV25⊕ => F3210BV25MG56:  
2-way normally open with direct operated plunger solenoid valve with Connector G (ISO228) 1/4", Seals in FPM, Orifice 2,5 mm, Coil 24V 50/60Hz (MG56, size 30).

Pneumatic symbol

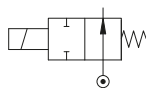

Diagram

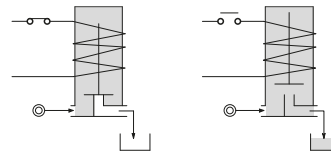

Operational characteristic

- Stainless Steel Body
- Guide pipe in Stainless Steel
- Mobile and fixed core in Stainless Steel
- Springs in Stainless Steel
- Sealing assemblies in FPM

- **OPTIONS (if requested):**
- Advance ring in silver

Technical characteristic

Maximum admitted pressure (bar)	50
Maximum fluid viscosity (mm <sup>2</sup> /s) 25cSt	25cSt
Ambient temperature: with class F coil (°C) -10 +55	-10 +55
Ambient temperature: with class H coil (°C) -10 +80	-10 +80
Mounting position	indifferent

▶ 2-way normally open with direct operated plunger solenoid valve

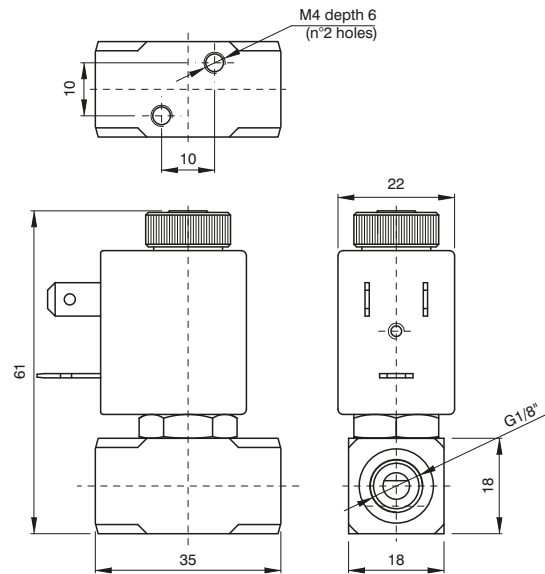

CODE "V" = Seals in FPM "C" = Coil	Connection G ISO 228	Orifice (mm)	KV (m³/h)	Differential pressure (bar)				Power Consumption			Coil C		Temp. range (°C)
				Min	Max		AC Inrush	VA Holding	DC Watt	Series	Size		
					AC	DC							
F3211AV12C	1/8"	1,2	0,04	0	19	19	12	8	6,5	MI	22	-10 +140	
F3211AV15C	1/8"	1,5	0,06	0	14	14	12	8	6,5	MI	22		
F3211AV20C	1/8"	2	0,09	0	8	8	12	8	6,5	MI	22		

N.B. For use with steam maximum admitted pressure PS is 2.5 bar (relative pressure)

Example: F3211AV12C => F3211AV12MI56:

2-way normally open with direct operated plunger solenoid valve with Connector G (ISO228) 1/8", Seals in FPM, Orifice 1,2 mm, Coil 24V 50/60Hz (MI56, size 22).

Pneumatic symbol

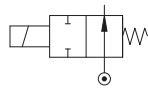

Diagram

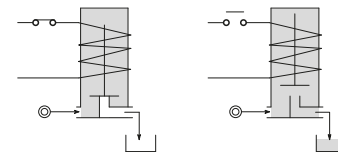

**Operational characteristic**

- Stainless Steel Body
- Guide pipe in Stainless Steel
- Mobile and fixed core in Stainless Steel
- Springs in Stainless Steel
- Sealing elements in FPM

**- OPTIONS (if requested):**

- Coil for potentially explosive environments meeting 'ATEX standards Ex m Serie XME'.

**Technical characteristic**

Maximum admitted pressure (bar)	50
Maximum fluid viscosity (mm²/s)	25cSt
Ambient temperature: with class F coil (°C)	-10 +55
Ambient temperature: with class H coil (°C)	-10 +80
Mounting position	indifferent



▶ 2-way normally open servo-actuated diaphragm solenoid valve in stainless steel AISI 316

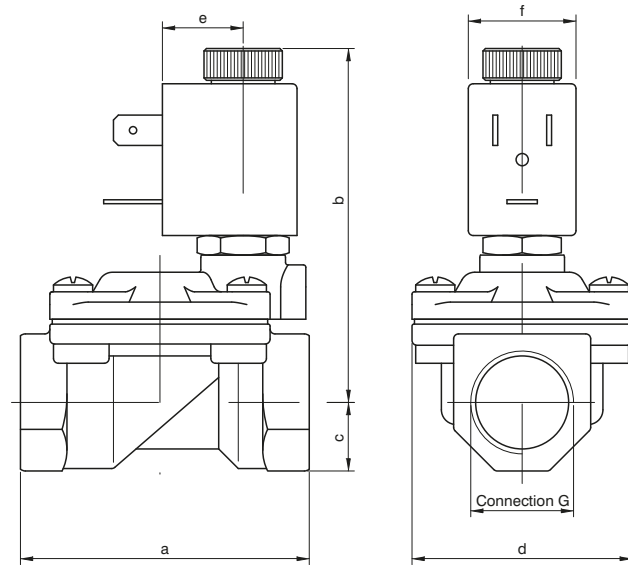

Connection	a	b	c	d	e	f	Weight (g)
G3/8"	59	74	11	45	16	22	300
G1/2"	59	74	13	45	16	22	320
G3/4"	80	78	16	55	16	22	550
G1"	100	88	20	72	16	22	1350

CODE "V" = Seals in FPM "C" = Coil	Connection G ISO 228	Orifice (mm)	KV (m³/h)	Differential pressure (bar)			Power Consumption			Coil "C"		Temp. range (°C)
				Min	Max		AC Inrush	VA Holding	DC Watt	Series	Size	
					AC	DC						
F3277CV12C	3/8"	12	2,2	0,15	15	15	12	8	6,5	MI	22	-10 +140
F3277DV12C	1/2"	12	2,5	0,15	15	15	12	8	6,5	MI	22	
F3277EV18C	3/4"	18	5,5	0,15	13	13	12	8	6,5	MI	22	
F3277FV25C	1"	24	10,2	0,15	10	10	12	8	6,5	MI	22	

N.B. For use with steam maximum admitted pressure PS is 2.5 bar (relative pressure)

Example: F3277CV12C => F3277CV12MI5:

2-way normally open servo-actuated diaphragm solenoid valve in stainless steel AISI 316 with Connector G (ISO228) 3/8", Seals in FPM, Orifice 12 mm, Coil 24V DC (MI5, size 22).

Pneumatic symbol

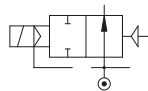

Diagram

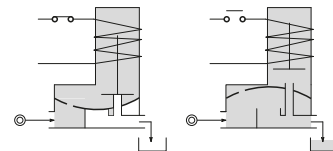

**Operational characteristic**

- Body and cover in Stainless Steel.
- Guide pipe in Stainless Steel
- Mobile and fixed core in Stainless Steel
- Springs in Stainless Steel
- Sealing assemblies in FPM

**- OPTIONS (if requested):**

- Coil for potentially explosive environments meeting 'ATEX standards Ex m Serie XME'.
- Seals for use with foodstuff fluids.
- Advance ring in silver

**Technical characteristic**

Minimum differential pressure (bar)	0,15
Maximum admitted pressure (bar)	25
Maximum fluid viscosity (mm <sup>2</sup> /s)	25cSt
Ambient temperature: with class F coil (°C)	-10 +55
Ambient temperature: with class H coil (°C)	-10 +80
Mounting position	Preferably with coil upwards

1  
AIR DISTRIBUTION

▶ 3-way direct acting solenoid valve

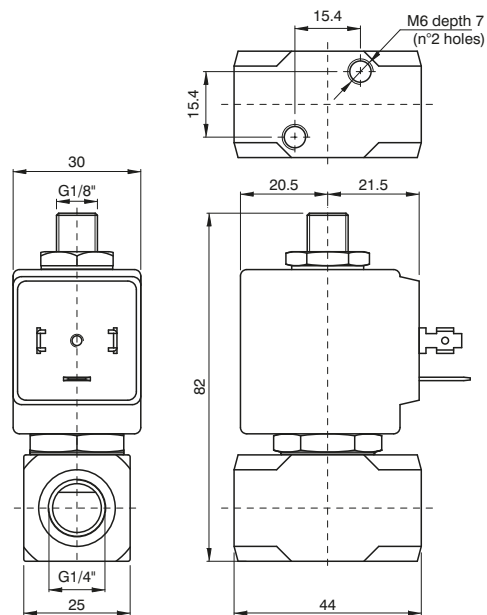

CODE "V"=Seals in FPM ⊕ = Coil	Connection G ISO 228	Orifice (mm)		KV (m³/h)	Differential pressure (bar)			Power Consumption			Coil ⊕		Temp. range (°C)
		alim.	scar.		Min	Max		AC Inrush	VA Holding	DC Watt	Series	Size	
						AC	DC						
<b>U Universal</b>													
F3310BV25U⊕	1/4"	2,5	2,4	0,16	0	5	4	20	15	10	MG	30	-10 +140

Example: F3310BV25G⊕ => F3310BV25GMG5:  
3-way direct acting solenoid valve with Connector G (ISO228) 1/4", Seals in FPM, Feed bore 2,5 mm, Exhaust bore 2,4 mm Coil 24V DC (MG5, size 30), N.O.

Pneumatic symbol		Diagram	N.C.		N.O.	
<b>Operational characteristic</b>		<b>Technical characteristic</b>				
<ul style="list-style-type: none"> <li>- Stainless Steel body</li> <li>- Guide pipe in Stainless Steel</li> <li>- Mobile and fixed core in Stainless Steel</li> <li>- Springs in Stainless Steel</li> <li>- Sealing assemblies in FPM</li> </ul> <b>- OPTIONS (if requested):</b> <ul style="list-style-type: none"> <li>- Advance ring in silver</li> </ul>		Maximum admitted pressure (bar)			Maximum running pressure + 10%	
		Maximum fluid viscosity (mm²/s)			25cSt	
		Ambient temperature: with class F coil (°C)			-10 +55	
		Ambient temperature: with class H coil (°C)			-10 +80	
		Mounting position			indifferent	
		Weight (g.)			150	

1 AIR DISTRIBUTION

3-way direct acting solenoid valve

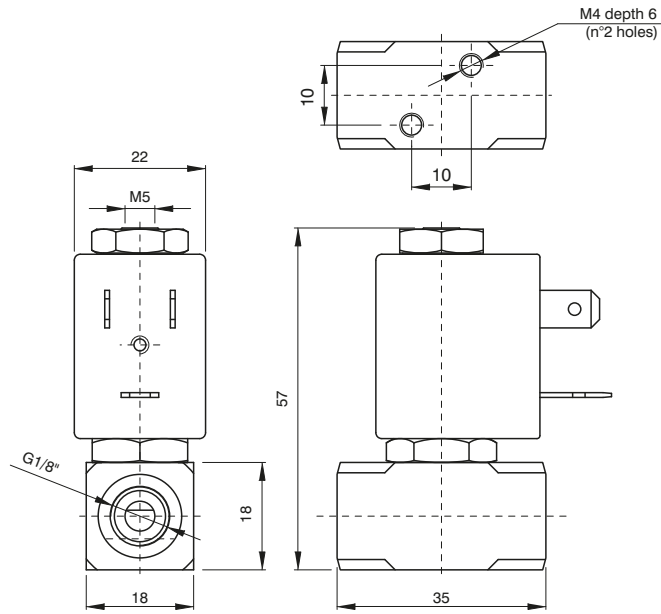

CODE "V"=Seals in FPM ⊕ = Bobna	Connection G ISO 228	Orifice (mm)		KV (m³/h)	Differential pressure (bar)			Power Consumption			Coil ⊕		Temp. range (°C)
		alim.	scar.		Min	Max		AC Spunto	VA Regime	DC Watt	Series	Size	
						AC	DC						
<b>U Universal</b>													
F3311AV15U⊕	1/8"	1,5	1,5	0,06	0	6	6	12	8	6,5	MI	22	-10 +140

Example: F3311AV15G⊕ => F3311AV15GM15:  
3-way direct acting solenoid valve with Connector G (ISO228) 1/8", Seals in FPM, Feed bore 1,5 mm, Exhaust bore 1,5 mm Coil 24V DC (MI5, size 22), N.O.

Pneumatic symbol

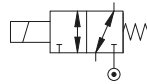

Diagram

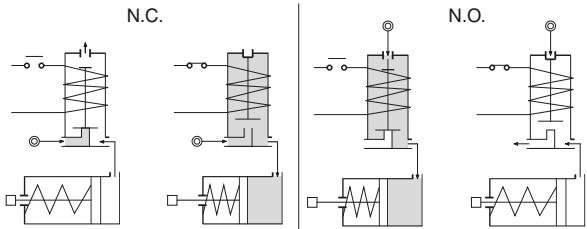

Operational characteristic

- Stainless Steel Body
- Guide pipe in Stainless Steel
- Mobile and fixed core in Stainless Steel
- Springs in Stainless Steel
- Sealing assemblies in FPM

- OPTIONS (if requested):

- Advance ring in silver
- Coil for potentially explosive environments meeting 'ATEX standards Ex m Serie XME'.
- Exhaust with hose mount.

Technical characteristic

Maximum admitted pressure (bar)	Maximum running pressure + 10%
Maximum fluid viscosity (mm <sup>2</sup> /s)	25cSt
Ambient temperature: with class F coil (°C)	-10 +55
Ambient temperature: with class H coil (°C)	-10 +80
Mounting position	indifferent
Weight (g.)	150

► 2-way normally closed servo-actuated towed membrane solenoid valve

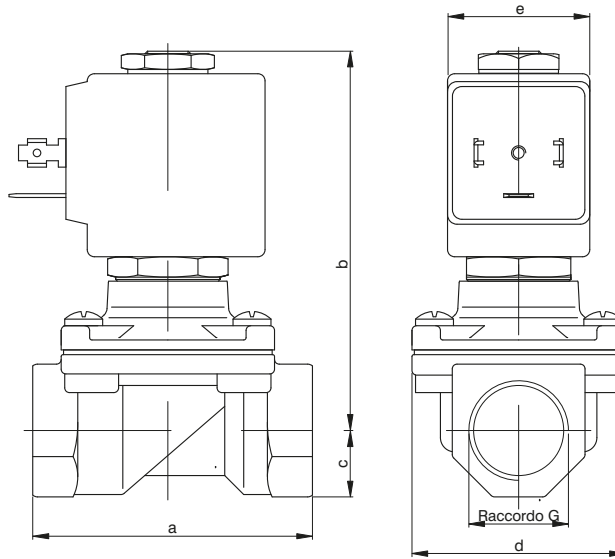

1  
AIR DISTRIBUTION

Connection	a	b	c	d	e	f	Weight (g) Series 2	Weight (g) Series 5
G3/8" Ø12	59	83	14	45	16	36	0,50	0,58
G1/2"	59	83	14	45	16	36	0,45	0,53
G3/4"	79	90	18	55		36	-	0,75
G1"	96	101	20	72		36	-	1,10

CODE "V"=Seals in FPM "E" = Coil	Connection G ISO 228	Orifice (mm)	KV (m³/h)	Differential pressure (bar)			Power Consumption			Coil Ⓜ		Temp. range (°C)
				Min	Max		AC Inrush	VA Holding	DC Watt	Series	Size	
					AC	DC						
F3108CV12Ⓜ	3/8"	12	2	0	10	-	20	15	-	MG	30	-10 +140
F3108DV12Ⓜ	1/2"	12	2.2	0	10	-	20	15	-	MG	30	
F3108CV12Ⓜ	3/8"	12	2	0	12	10	40	30	27	MK	36	
F3108DV12Ⓜ	1/2"	12	2.2	0	12	10	40	30	27	MK	36	
F3108EV18Ⓜ	3/4"	18	4.5	0	9	-	40	30	-	MK	36	
F3108FV25Ⓜ	1"	24	8.5	0	7	-	40	30	-	MK	36	
F3108EV18CⓂ	3/4"	18	4.5	0	-	9	-	-	27	MK	36	
F3108FV25CⓂ	1"	24	8.5	0	-	8	-	-	27	MK	36	

Example: F3108DV12Ⓜ => F3108DV12MG5:

2-way normally closed in brass with towed membrane solenoid valve with Connector G (ISO228) 1/2", Seals in FPM, Orifice 12 mm, Coil 24V DC (MG5, size 30).

Pneumatic symbol

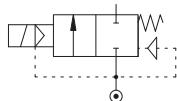

Diagram

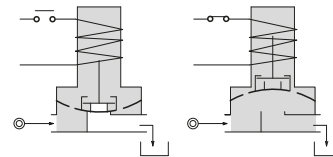

**Operational characteristic**

- Body and cover in Brass
- Guide pipe in Stainless Steel
- Mobile and fixed core in Stainless Steel
- Springs in Stainless Steel
- Sealing assemblies in FPM
- **OPTIONS (if requested):**
- Surface treatment in chemical nickel-plating

**Technical characteristic**

Maximum admitted pressure (bar)	25
Maximum fluid viscosity (mm²/s)	25cSt
Ambient temperature: with class F coil (°C)	-10 +55
Ambient temperature: with class H coil (°C)	-10 +80
Mounting position	Preferably with coil upwards

▶ 2-way normally closed servo-actuated piston solenoid valve 1/4"

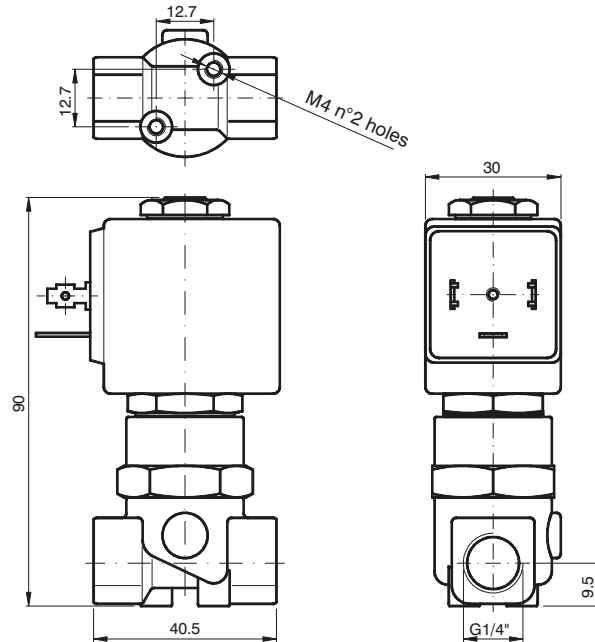

1  
AIR DISTRIBUTION

CODE "V" = Seals in FPM ⊕ = Coil	Connection G ISO 228	Orifice (mm)	KV (m³/h)	Differential pressure (bar)			Power Consumption			Coil ⊕		Temp. range (°C)
				Min	Max		AC Inrush	VA Holding	DC Watt	Series	Size	
					AC	DC						
F3119BV52⊕	1/4"	5,2	0,47	1,5	50	50	20	15	10	MG	30	-10 +140

Example: F3119BV52⊕ => F3119BV52MG5:  
2-way normally closed servo-actuated piston solenoid valve in brass with Connector G (ISO228) 1/4", Seals in FPM, Orifice 5,2 mm, Coil 24V DC (MG5, size 30).

Pneumatic symbol

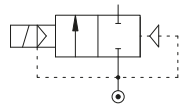

Diagram

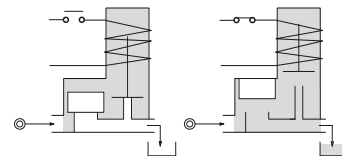

**Operational characteristic**

- Body and cover in Brass
- Guide pipe in Stainless Steel
- Mobile and fixed core in Stainless Steel
- Springs in Stainless Steel
- Piston in Brass.
- Guide slide in loaded PTFE.
- Main shutter in PTFE.
- Remaining sealing elements in FPM.

- OPTIONS (if requested):**
- Surface treatment in chemical nickel-plating

**Technical characteristic**

Minimum differential pressure (bar)	1
Maximum admitted pressure (bar)	40
Maximum running pressure Versione /1 (bar)	60
Maximum fluid viscosity (mm <sup>2</sup> /s)	25cSt
Ambient temperature: with class F coil (°C)	-10 +55
Ambient temperature: with class H coil (°C)	-10 +80
Mounting position	630
Weight (g.)	Preferably with coil upwards

► 2-way normally closed, servo-actuated piston solenoid valve

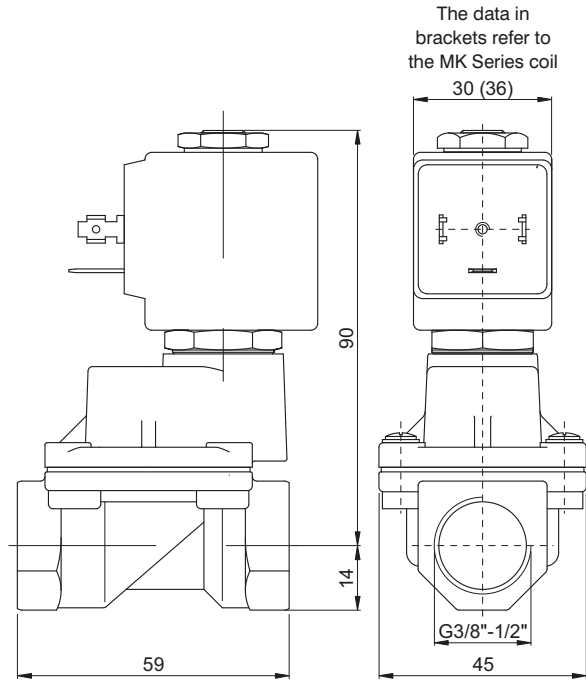

CODE "V"=Seals in FPM ⊕ = Coil	Connection G ISO 228	Orifice (mm)	KV (m³/h)	Differential pressure (bar)				Power Consumption			Coil ⊕		Temp. range (°C)
				Min	Max		AC Inrush	VA Holding	DC Watt	Series	Size		
					AC	DC							
F3119CV12⊕	3/8"	12	2	1	30	30	20	15	10	MG	30	-10 +140	
F3119DV12⊕	1/2"	12	2.2	1	30	30	20	15	10	MG	30		
F3119CV12/1⊕	3/8"	12	2	1	50	50	40	30	27	MK	36		
F3119DV12/1⊕	1/2"	12	2.2	1	50	50	40	30	27	MK	36		

Example: F3119DV12⊕ => F3108DV12MG5:

2-way normally closed servo-actuated piston solenoid valve in brass with Connector G (ISO228) 1/2", Seals in FPM, Orifice 12 mm, Coil 24V DC (MG5, size 30).

Pneumatic symbol

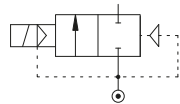

Diagram

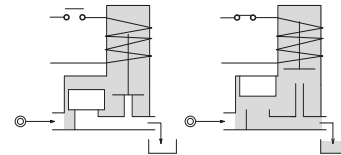

**Operational characteristic**

- Body and cover in Brass
- Guide pipe in Stainless Steel
- Mobile and fixed core in Stainless Steel
- Springs in Stainless Steel
- Piston in Brass.
- Guide slide in loaded PTFE.
- Main shutter in PTFE.
- Remaining sealing elements in FPM.

- **OPTIONS (if requested):**
- Surface treatment in chemical nickel-plating

**Technical characteristic**

Minimum differential pressure (bar)	1
Maximum admitted pressure (bar)	40
Maximum running pressure Versione /1 (bar)	60
Maximum fluid viscosity (mm <sup>2</sup> /s)	25cSt
Ambient temperature: with class F coil (°C)	-10 +55
Ambient temperature: with class H coil (°C)	-10 +80
Mounting position	Preferably with coil upwards
Weight (gr.) with MG Series Coil	630
Weight (gr.) with MK Series Coil	710



► 2-way normally closed servo-actuated piston solenoid valve for use with steam

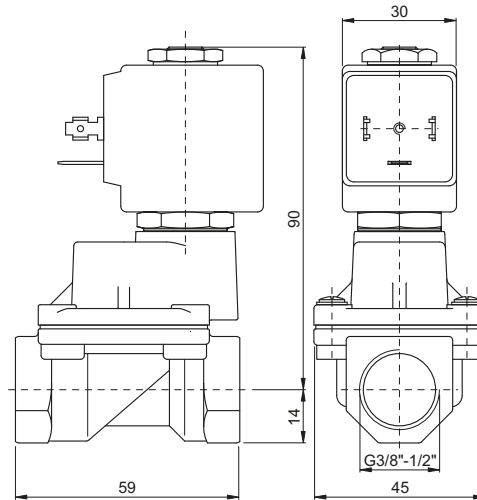

1  
AIR DISTRIBUTION

CODE "V"=Seals in FPM ⊕ = Coil	Connection G ISO 228	Orifice (mm)	KV (m³/h)	Differential pressure (bar)			Power Consumption			Coil ⊕		Temp. range (°C)
				Min	Max		AC Inrush	VA Holding	DC Watt	Series	Size	
					AC	DC						
F3119CW12/1⊕	3/8"	12	2	2,5	9	9	20	15	10	MG	30	-10 +180
F3119DW12/1⊕	1/2"	12	2.2	2,5	9	9	20	15	10	MG	30	-10 +180

Example: F3119DW12/1⊕ => F3119DW12/1MG5:  
2-way normally closed servo-actuated piston solenoid valve in brass with Connector G (ISO228) 1/2", Seals in FPM, Orifice 12 mm, Coil 24V DC (MG5, size 30).

Pneumatic symbol		Diagram	
<b>Operational characteristic</b>		<b>Technical characteristic</b>	
<ul style="list-style-type: none"> <li>- Body and cover in Brass</li> <li>- Guide pipe in Stainless Steel</li> <li>- Mobile and fixed core in Stainless Steel</li> <li>- Springs in Stainless Steel</li> <li>- Piston in Stainless Steel.</li> <li>- Guide slide in loaded PTFE.</li> <li>- Sealing elements in PTFE/FPM.</li> </ul> <p><b>- OPTIONS (if requested):</b></p> <ul style="list-style-type: none"> <li>- Surface treatment in chemical nickel-plating</li> <li>- Steam sealing up to +160°C</li> </ul>		Minimum differential pressure (bar)	2,5
		Ambient temperature: only with class H Coil (°C)	-10 +80
		Mounting position	Preferably with coil upwards
		Weight (g.)	630



2-way solenoid normally closed valve, direct plunger operation, with housing for potentially explosive environments certified: CESI 03 ATEX 344 ExII2G/D Eex "d" IIC T6

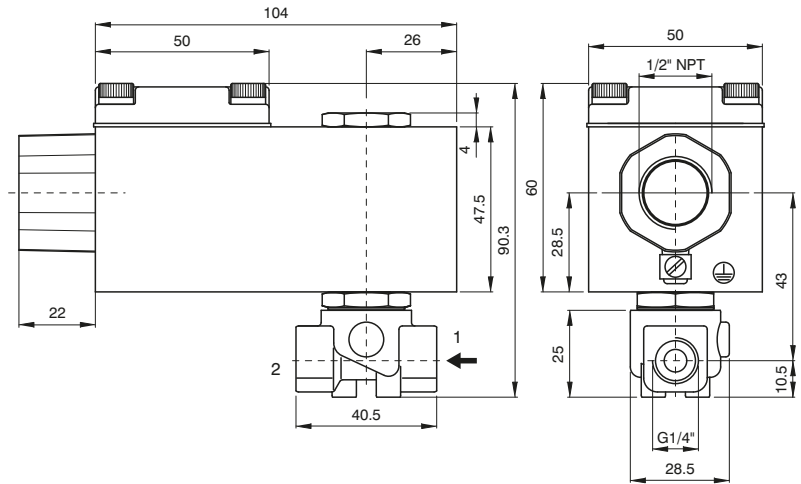

CODE "V"=Seals in FPM ⊕ = Coil	Connection G ISO 228	Orifice (mm)	KV (m³/h)	Differential pressure (bar)			Power Consumption		Temp. range (°C)	Coil ⊕ Series A6 (CURRENT)
				Min	Max		AC Inrush	DC Watt		
					AC	DC				
FX3106BV35⊕	1/4"	3,5	0,32	0	10	8	12	8	-10 +140	A6B=24 Volt (AC 50/60Hz)
FX3106BV45⊕	1/4"	4,5	0,41	0	6,5	3,5	12	8		A6E=220/230 Volt (AC 50/60Hz)
										A60=12 Volt (DC)
										A61=24 Volt (DC)

N.B. The solenoid valve is suited for intercepting only fluids that are NOT potentially explosive.

Example: FX3106BV35b => FX3106BV35A60:

2-way solenoid normally closed valve, direct plunger operation, with housing for potentially explosive environments certified:  
CESI 03 ATEX 344 ExII2G/D Eex "d" IIC T6 with Connector G (ISO228) 1/4", Seals in FPM, Orifice 3,5 mm, Coil 12V DC (A60).

Pneumatic symbol

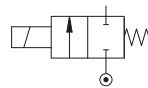

Diagram

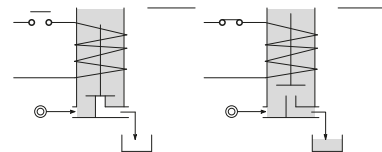

**Operational characteristic**

- Brass Body
- Container in light red coloured alloy
- Electrical connection 1/2" NPT
- Sealing elements in FPM
- **OPTIONS (if requested):**
- Manual operation
- Surface treatment in chemical nickel-plating
- Inserted stainless steel seating

**Technical characteristic**

Maximum admitted pressure (bar)	80
Maximum fluid viscosity (mm <sup>2</sup> /s)	25cSt
Ambient temperature (°C)	-10 +40
Mounting position	With coil upwards
Weight (g.)	600





2-way normally closed direct acting solenoid valve with housing for potentially explosive environments certified: CESI 03 ATEX 344 ExII2G/D Eex "d" IIC T6

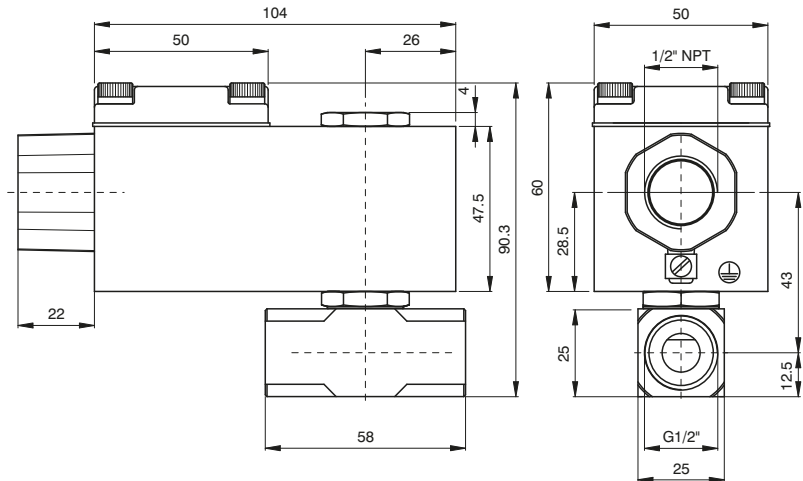

CODE "v"=Seals in FPM ⊕ = Coil	Connection G ISO 228	Orifice (mm)	KV (m <sup>3</sup> /h)	Differential pressure (bar)			Power Consumption		Temp. range (°C)	Coil ⊕ Series A6 (CURRENT)
				Min	Max		AC Inrush	DC Watt		A6B=24 Volt (AC 50/60Hz) A6E=220/230 Volt (AC 50/60Hz) A60=12 Volt (DC) A61=24 Volt (DC)
					AC	DC				
FX3106DV52⊕	1/2"	5,2	0,47	0	4	1,8	12	8	-10 +140	
FX3106DV64⊕	1/2"	6,4	0,64	0	3	1	12	8	-10 +140	

N.B. The solenoid valve is suited for intercepting only fluids that are NOT potentially explosive.  
Example: FX3106DV52⊕ => FX3106DV52A60:  
2-way solenoid normally closed valve, direct plunger operation, with housing for potentially explosive environments certified:  
CESI 03 ATEX 344 ExII2G/D Eex "d" IIC T6, with Connector G (ISO228) 1/2", Seals in FPM, Orifice 5,2 mm, Coil 12V DC (A60).

Pneumatic symbol

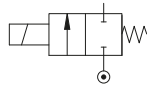

Diagram

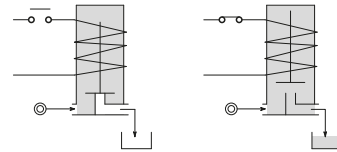

**Operational characteristic**

- Brass Body
- Container in light red coloured alloy
- Electrical connection 1/2" NPT
- Sealing elements in FPM
- **OPTIONS (if requested):**
  - Manual operation
  - Surface treatment in chemical nickel-plating
  - Inserted stainless steel seating

**Technical characteristic**

Maximum admitted pressure (bar)	80
Maximum fluid viscosity (mm <sup>2</sup> /s)	25cSt
Ambient temperature (°C)	-10 +40
Mounting position	With coil upwards
Weight (g.)	660

2-Way normally closed solenoid valve, servo-actuated diaphragm, with housing for potentially explosive environments certified: CESI 03 ATEX 344 ExII2G/ D Eex "d" IIC T6

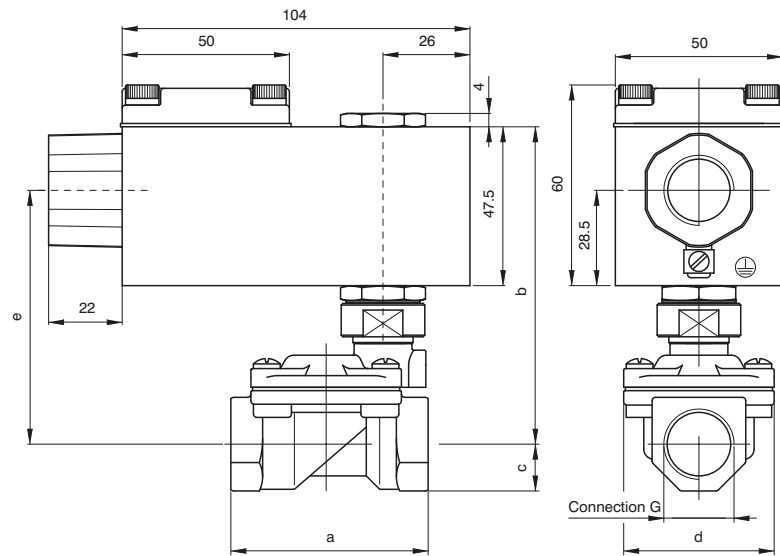

Connection G	a	b	c	d	e	Weight (g)
G1/4" Ø10	49	90	11	32	71	720
G3/8" Ø12	59	95	14	45	76	920
G1/2" Ø12	59	95	14	45	76	920
G3/4"	79	101	18	54	82	1100
G1"	96	110	20	72	91	1500

CODE "V" = Seals in FPM ⊗ = Coil	Connection G ISO 228	Orifice (mm)	KV (m <sup>3</sup> /h)	Differential pressure (bar)			Power Consumption		Temp. range (°C)
				Min	Max		AC Inrush	DC Watt	
					AC	DC			
FX3107BV10⊗	1/4"	10	1,5	0,15	15	15	12	8	-10 +140
FX3107CV12⊗	3/8"	12	2,2	0,15	15	15	12	8	
FX3107DV12⊗	1/2"	12	2,5	0,15	15	15	12	8	
FX3107EV18⊗	3/4"	18	5,5	0,15	13	13	12	8	
FX3107FV25⊗	1"	24	10,2	0,15	10	10	12	8	

Coil ⊗ Series A6 CURRENT
A6B=24 Volt (AC 50/60Hz)
A6E=220/230 Volt (AC 50/60Hz)
A60=12 Volt (DC)
A61=24 Volt (DC)

N.B. The solenoid valve is suited for intercepting only fluids that are NOT potentially explosive.

Example: FX3107BV101⊗ => FX3107BV101A60.

2-Way normally closed solenoid valve, servo-actuated diaphragm, with housing for potentially explosive environments certified: CESI 03 ATEX 344 ExII2G/D Eex "d" IIC T6, with Connector G (ISO228) 1/4", Seals in FPM, Orifice 10 mm, Coil 12V DC (A60).

Pneumatic symbol

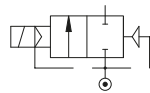

Diagram

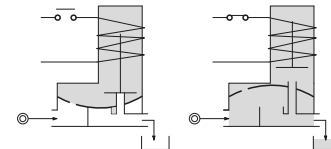

#### Operational characteristic

- Body and cover in Brass
- Container in light red coloured alloy
- Electrical connection 1/2" NPT
- Sealing elements in FPM

#### - OPTIONS (if requested):

- Surface treatment in chemical nickel-plating
- Version with slowed commutation

#### Technical characteristic

Minimum differential pressure (bar)	0,15
Maximum admitted pressure (bar)	25
Maximum fluid viscosity (mm <sup>2</sup> /s)	25cSt
Ambient temperature (°C)	-10 +40
Mounting position	Preferably with coil upwards



► **2-Way normally closed direct acting solenoid valve with housing for potentially explosive environments certified: CESI 03 ATEX 344 ExII2G/D Eex "d" IIC T6**

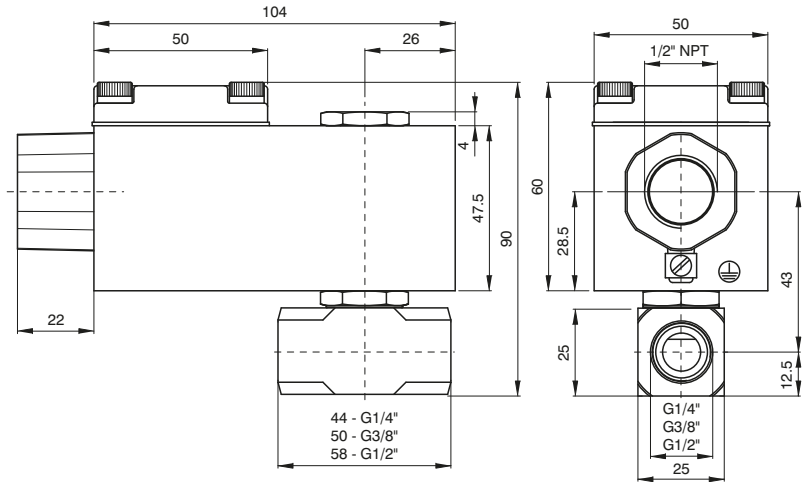

CODE "V"= Seals in FPM ⊕ = Coil	Connection G ISO 228	Orifice (mm)	KV (m <sup>2</sup> /h)	Differential pressure (bar)			Power Consumption		Temp. range (°C)	Coil ⊕ Series A6  CURRENT
				Min	Max		AC Inrush	DC Watt		
					AC	DC				
FX3110BV25⊕	1/4"	2,5	0,15	0	16	14	12	8	-10 +140	A6B=24 Volt (AC 50/60Hz) A6E=220/230 Volt (AC 50/60Hz) A60=12 Volt (DC) A61=24 Volt (DC)
FX3110BV35⊕	1/4"	3,5	0,32	0	10	8	12	8		
FX3110BV45⊕	1/4"	4,5	0,41	0	6,5	3,5	12	8		
FX3110CV35⊕	3/8"	3,5	0,32	0	10	8	12	8		
FX3110CV52⊕	3/8"	5,2	0,47	0	4	1,8	12	8		
FX3110DV35⊕	1/2"	3,5	0,32	0	10	8	12	8		
FX3110DV52⊕	1/2"	5,2	0,47	0	4	1,8	12	8		
FX3110DV64⊕	1/2"	6,4	0,64	0	3,5	1	12	8		

N.B. The solenoid valve is suited for intercepting only fluids that are NOT potentially explosive.

Example: FX3110BV25⊕ => FX3110BV25A60:

2-Way normally closed direct acting solenoid valve with housing for potentially explosive environments certified:

CESI 03 ATEX 344 ExII2G/D Eex "d" IIC T6, with Connector G (ISO228) 1/4", Seals in FPM, Orifice 2,5 mm, Coil 12V DC (A60).

Pneumatic symbol

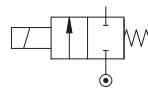

Diagram

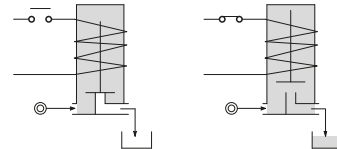

**Operational characteristic**

- Stainless Steel Body
- Container in light red coloured alloy
- Electrical connection 1/2" NPT
- Sealing elements in FPM

- OPTIONS (if requested):**
- Advance ring in silver

**Technical characteristic**

Maximum admitted pressure (bar)	100
Maximum fluid viscosity (mm <sup>2</sup> /s)	25cSt
Ambient temperature (°C)	-10 +40
Mounting position	with coil upwards
Weight (g.)	660

1  
AIR DISTRIBUTION

**2-Way normally closed servo-actuated diaphragm solenoid valve in stainless steel AISI 316, with housing for potentially explosive environments certified: CESI 03 ATEX 344 ExII2G/D Eex "d" IIC T6**

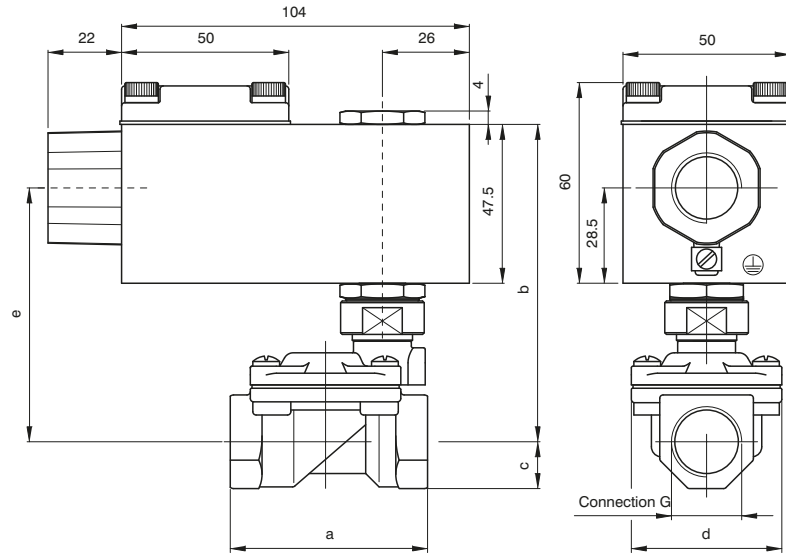

Connection G	a	b	c	d	e	Weight (g)
G3/8"	59	95	14	45	76	1120
G1/2"	59	95	14	45	76	1110
G3/4"	79	101	18	54	82	1100
G1"	96	110	20	72	91	1500

CODE	Connection G ISO 228	Orifice (mm)	KV (m³/h)	Differential pressure (bar)			Power Consumption		Temp. range (°C)
				Min	Max		AC Inrush	DC Watt	
					AC	DC			
FX3177CV121Ⓢ	3/8"	12	2,2	0,15	15	15	12	8	-10 +140
FX3177DV121Ⓢ	1/2"	12	2,5	0,15	15	15	12	8	
FX3177EV181Ⓢ	3/4"	18	5,5	0,15	13	13	12	8	
FX3177FV251Ⓢ	1"	24	10,2	0,15	10	10	12	8	

Coil Ⓢ Series A6
CURRENT
A6B=24 Volt (AC 50/60Hz)
A6E=220/230 Volt (AC 50/60Hz)
A6O=12 Volt (DC)
A6I=24 Volt (DC)

N.B. The solenoid valve is suited for intercepting only fluids that are NOT potentially explosive.

Example: FX3177CV121Ⓢ => FX3177CV121A60:

2-Way normally closed servo-actuated diaphragm solenoid valve in stainless steel AISI 316, with housing for potentially explosive environments certified: CESI 03 ATEX 344 ExII2G/D Eex "d" IIC T6, with Connector G (ISO228) 3/8", Seals in FPM, Orifice 12 mm, Coil 12V DC (A60).

Pneumatic symbol		Diagram											
<b>Operational characteristic</b> - Body and cover in Stainless Steel - Container in light red coloured alloy - Electrical connection 1/2" NPT - Sealing elements in FPM  <b>- OPTIONS (if requested):</b> - Version with slowed commutation		<b>Technical characteristic</b> <table border="1" style="width: 100%;"> <tr> <td>Minimum differential pressure (bar)</td> <td>0,15</td> </tr> <tr> <td>Maximum admitted pressure (bar)</td> <td>25</td> </tr> <tr> <td>Maximum fluid viscosity (mm²/s)</td> <td>25cSt</td> </tr> <tr> <td>Ambient temperature (°C)</td> <td>-10 +40</td> </tr> <tr> <td>Mounting position</td> <td>Preferably with coil upwards</td> </tr> </table>		Minimum differential pressure (bar)	0,15	Maximum admitted pressure (bar)	25	Maximum fluid viscosity (mm²/s)	25cSt	Ambient temperature (°C)	-10 +40	Mounting position	Preferably with coil upwards
Minimum differential pressure (bar)	0,15												
Maximum admitted pressure (bar)	25												
Maximum fluid viscosity (mm²/s)	25cSt												
Ambient temperature (°C)	-10 +40												
Mounting position	Preferably with coil upwards												

► **MG Series coil (Size 30 mm), class F**

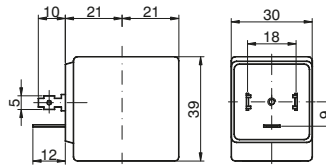

Ordering code	
<b>MG</b> <sup>T</sup>	
VOLTAGE	
56=24 Volt (AC 50/60Hz)	
<sup>T</sup>	58=220/230 Volt (AC 50/60Hz)
5=24 Volt (DC)	
4=12 Volt (DC)	

Options:  
Electrical connection via cables  
Special voltages and powers.

Operational characteristic							
Class of insulation	Tolerance on AC voltage	Tolerance on DC voltage	Degree of protection with connector fitted	Continuous service	Electrical conn.	Connectors	Weight (g.)
F	+15% -10%	± 10%	IP65	ED100%	DIN 43650A	PG9 Codice 10349000	120

► **MI Series coil (Size 22 mm), class F**

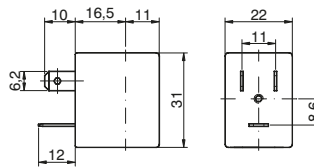

Ordering code	
<b>MI</b> <sup>T</sup>	
VOLTAGE	
56=24 Volt (AC 50/60Hz)	
<sup>T</sup>	58=220/230 Volt (AC 50/60Hz)
5=24 Volt (DC)	
4=12 Volt (DC)	
21=48-50 Volt (AC 50/60Hz)	

Options:  
Electrical connection via cables  
Special voltages and powers.

Operational characteristic							
Class of insulation	Tolerance on AC voltage	Tolerance on DC voltage	Degree of protection with connector fitted	Continuous service	Electrical conn.	Connectors	Weight (g.)
F	+15% -10%	± 10%	IP65	ED100%	DIN 43650A	PG9 Codice 10349000	120

► **MK Series coil (Size 36 mm), class H**

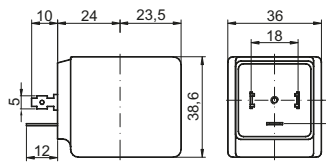

Ordering code	
<b>MK</b> <sup>T</sup>	
VOLTAGE	
56=24 Volt (AC 50/60Hz)	
<sup>T</sup>	58=220/230 Volt (AC 50/60Hz)
5=24 Volt (DC)	
4 = 12 Volt (DC)	

Options:  
Electrical connection via cables  
Special voltages and powers.

Operational characteristic							
Class of insulation	Tolerance on AC voltage	Tolerance on DC voltage	Degree of protection with connector fitted	Continuous service	Electrical conn.	Connectors	Weight (g.)
F	+15% -10%	± 10%	IP00	ED100%	DIN 43650A	PG9 Codice 10349000	200

► **Coils 2G Ex mb IIC T4-T6; II2D Ex mb IIIC T85°C-T135°C (Size 30 mm), Class H**

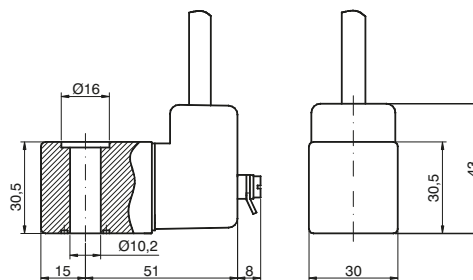

Ordering code	
<b>XME</b> <sup>T</sup>	
VOLTAGE	
56=24 Volt (AC 50/60Hz)	
<sup>T</sup>	58=220/230 Volt (AC 50/60Hz)
5=24 Volt (DC)	
4 = 12 Volt (DC)	

Options:  
Electrical connection via cables  
Special voltages and powers.

Operational characteristic						
Class of insulation	Tolerance on AC voltage	Tolerance on DC voltage	Degree of protection with connector fitted	Continuous service	Electrical conn.	Weight (g.)
F	+15% -10%	± 10%	Ip00	ED100%	3m cable	250

2way angle seat valve pneumatically operated

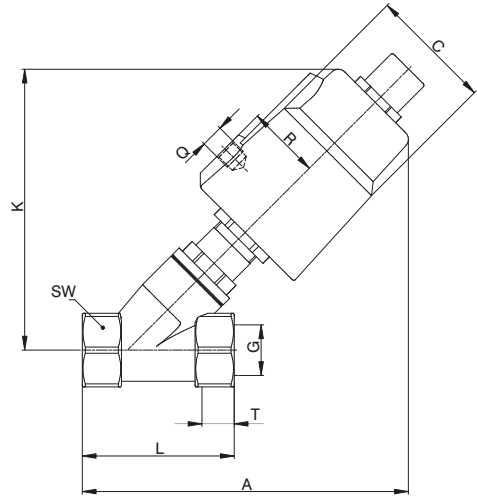

Table of dimensions

CODE AISI316	CODE AISI304	Connection G	Actuator (mm)	C (mm)	R (mm)	K (mm)	Q (mm)	T (mm)	A (mm)	L (mm)	SW (mm)
PVF40115-316	PVF40115-304	1/2"	40	50,5	27	111	1/8"	15	119	68	27
PVF50115-316	PVF50115-304	1/2"	50	60	33	124	1/8"	15	131	68	27
PVF50120-316	PVF50120-304	3/4"	50	60	33	128	1/8"	16	136	75	32
PVF50125-316	PVF50125-304	1"	50	60	33	136	1/8"	17	145	90	40
PVF63125-316	PVF63125-304	1"	63	75	41	162	1/8"	17	169	90	40
PVF63132-316	PVF63132-304	1 -1/4"	63	75	41	174	1/8"	21	187	116	50
PVF63140-316	PVF63140-304	1 -1/2"	63	75	41	175	1/8"	21	187	116	56
PVF63150-316	PVF63150-304	2"	63	75	41	183	1/8"	22	201	138	69
PVF125AL165-316	PVF125AL165-304	2-1/2"	125-Aluminium	148	74	302	1/4"	26	320	178	85
PVF125AL180-316	PVF125AL180-304	3"	125-Aluminium	148	74	313	1/4"	27	372	210	100

Technicals data

CODE AISI316	CODE AISI304	Connection G	KV m/h	Actuator (mm)	Maximum ΔP (bar)		Piloting pressure (bar)	Weight (g.)
					Above seat	Under seat		
PVF40115-316	PVF40115-304	1/2"	4,8	40	16	13	3 ÷ 8	765
PVF50115-316	PVF50115-304	1/2"	4,8	50	16	14		952
PVF50120-316	PVF50120-304	3/4"	10	50	16	14		1062
PVF50125-316	PVF50125-304	1"	14	50	16	8		1371
PVF63125-316	PVF63125-304	1"	14	63	16	13		2006
PVF63132-316	PVF63132-304	1 -1/4"	23	63	16	8		2575
PVF63140-316	PVF63140-304	1 -1/2"	30	63	16	5		2714
PVF63150-316	PVF63150-304	2"	70	63	9	3		3634
PVF125AL165-316	PVF125AL165-304	2-1/2"	107	125-Aluminium	16	9		9713
PVF125AL180-316	PVF125AL180-304	3"	157	125-Aluminium	16	5		13003

Pneumatic symbol

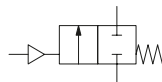

Operational characteristic

- High flow rate thanks to Body configuration with inclined seating.
- Anti water hammer functioning with input below shutter.
- Pneumatically operated valve with stainless steel Body, resistant to ambient corrosion.
- Self-levelling shutter to ensure improved sealing.
- Optical position indicator.
- May be used with back pressure for gaseous fluids.
- Self-adjusting maintenance free stuffer gasket package.
- Valves may be mounted in all positions.
- **OPTIONS:**
- Connection type: GAS ISO / NPT

Valve Body technical characteristics

- Fluid temperature: -10°C ÷ + 180°C
- Temperature: -10°C ÷ + 80°C
- Fluid viscosity: max. 600cSt.
- Shutter: PTFE.
- Gasket packet with PTFE, FKM stuffer

Actuator technical characteristics

- Body AISI 304
- Pilot fluid dry or lubricated Air, gas and neutral fluids.
- Temperature fluid max. + 60°C.

Proximity Sensor

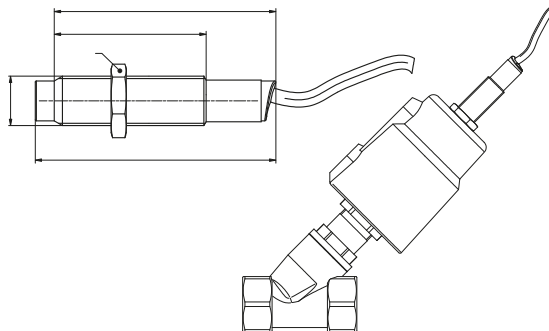

Ordering code

PVF.1.S

OUTPUT TYPE

- 01 = NPN (N.C.)
- 02 = NPN (N.O.)
- 03 = PNP (N.C.)
- 04 = PNP (N.O.)

Nickel brass sensor, usable on valves up to size 2 inches for detection ON - OFF  
Cable: 2m

Operational characteristic					
Maximum current	Voltage field	Temperature (°C)	Detection Distance	Protection grade	Weight (g)
100 mA	10 ÷ 30V DC	-10°C ÷ +70°C	3mm (max) ± 10 %	IP67	68



## Series 514/N

### General

The **514/N** Solenoid valves, are 2 stage valves actuated electro-pneumatically. A series 300 directly operated solenoid valve actuates pneumatically the principal power distributor.

Everything is well integrated in a practical configuration that also permits applications where there is limited space. Used primarily to operate rotary actuators and wherever there is a **NAMUR** standard installation plan.

The pilot air is normally taken from the inlet port (autofeed) and the only actuating signal is electric.

The range of the solenoid valves, as far as dimensions and mechanical construction, is similar to series 200. We have therefore solenoid valves G 1/4" with identical pneumatic characteristics that are, however, actuated electrically. They have a balanced spool, insensitive to presence or absence of pressure. They are constructed in 3 and 5 way with 1 solenoid (monostable) or 2 solenoids (bistable).

"NAMUR" interface dimensions:  
according to standard (VDI/VDE 3847 July 2003)

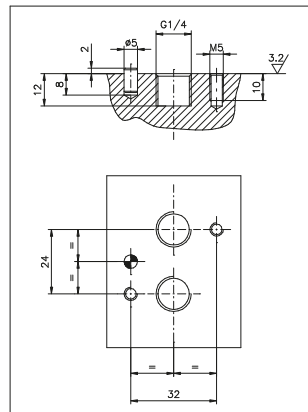

### Construction characteristics

Body	Aluminium
Spacer	Technopolymer
Seals	NBR
Springs	Spring steel
Operators	Aluminium
Spools	Nickel plated steel
Screws	Zinc coated Steel

### Use and maintenance

This valves have an average life of 15 million cycles depending on the application and air quality.

Filtered and lubricated air using specified lubricants will reduce the wear of the seals and ensures long and trouble free operation.

Please ensure that the valve is being used according with the manufacturers specification, such as air pressure and temperature.

The exhaust port of the distributor has to be protected in a dusty and dirty environment.

Repair kits including the spool complete with seals are available for overhauling the valves.

However, although this is a simple operation it should be carried out by a competent person.

**ATTENTION:** use hydraulic oil class H for lubrication such as MAGNA GC 32 (Castrol).

**Solenoid - Spring**

Coding: 514/N.ⓕ.0.1.M2

**Operational characteristics**

Fluid	Filtered air. No lubrication needed, if applied it shall be continuous
Max working pressure (bar)	10
Temperature °C	-10 ÷ +50
Flow rate at 6 bar with Δp=1 (Nl/min)	1030
Orifice size (mm)	7
Working ports size	G 1/4"

FUNCTION
ⓕ 32 = 3 ways
52 = 5 ways

5 ways

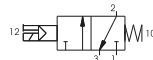
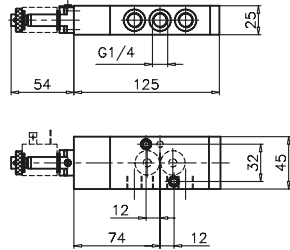

Weight 450 g  
Minimum working pressure 2,5 bar

514/N.52.0.1.M2

3 ways

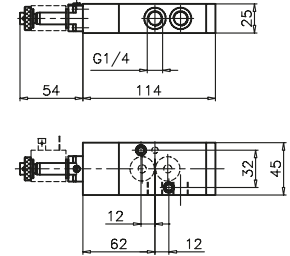

Weight 390 g  
Minimum working pressure 2,5 bar

514/N.32.0.1.M2

**Solenoid-Differential**

Coding: 514/N.ⓕ.0.12.M2

**Operational characteristics**

Fluid	Filtered air. No lubrication needed, if applied it shall be continuous
Max working pressure (bar)	10
Temperature °C	-10 ÷ +50
Flow rate at 6 bar with Δp=1 (Nl/min)	1030
Orifice size (mm)	7
Working ports size	G 1/4"

FUNCTION
ⓕ 32 = 3 ways
52 = 5 ways

5 ways

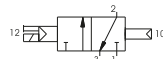
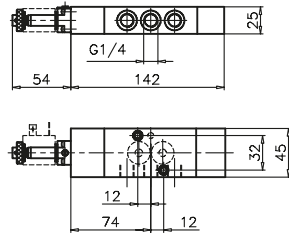

Weight 450 g  
Minimum working pressure 2,5 bar

514/N.52.0.12.M2

3 ways

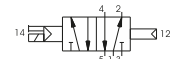
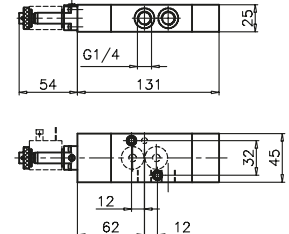

Weight 390 g  
Minimum working pressure 2,5 bar

514/N.32.0.12.M2

**Solenoid-Solenoid**

Coding: 514/N.ⓕ.0.0.M2

**Operational characteristics**

Fluid	Filtered air. No lubrication needed, if applied it shall be continuous
Max working pressure (bar)	10
Temperature °C	-10 ÷ +50
Flow rate at 6 bar with Δp=1 (Nl/min)	1030
Orifice size (mm)	7
Working ports size	G 1/4"

FUNCTION
ⓕ 32 = 3 ways
52 = 5 ways

3 ways

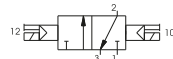
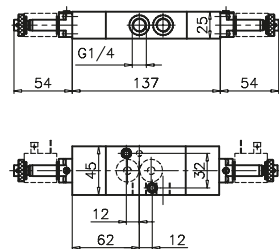

Weight 390 g  
Minimum working pressure 2,5 bar

514/N.32.0.0.M2

5 ways

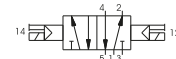
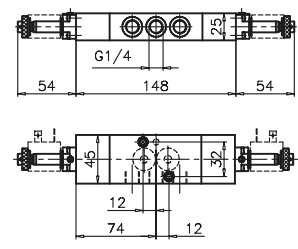

Weight 450 g  
Minimum working pressure 2,5 bar

514/N.52.0.0.M2

AIR DISTRIBUTION

1





**Series T514**

**General**

**TECNO-NAMUR** are 5/2 and 4/2 valves are solenoid valves pneumatically or electrically actuated. They are used in industrial automation applications or whenever a **NAMUR** mounting plane is available.

Is available in 5/2, 4/2 and all-purposes versions. The final user can switch from one version to another by simply changing interface plate and adding/removing a plug.

**TECNO-NAMUR** valves are produced using the most up to date technical features, granting flexible design and elevated characteristics over standard products. Superior performance is further enhanced by the use of innovative materials of construction.

**Construction characteristics**

Body	Technopolymer
Spacer	Technopolymer
Seals	Nitrile rubber
Springs	Stainless Steel
Operators	Technopolymer
Spools	Nickel plated steel
Screws	Zinc coated Steel

**Note:**

"Although accurately described, the 4/2 valve actually functions as a 3/2 normally closed valve and should be used as such."

**"NAMUR" interface dimensions:**

according to standard (VDI/VDE 3847 July 2003)

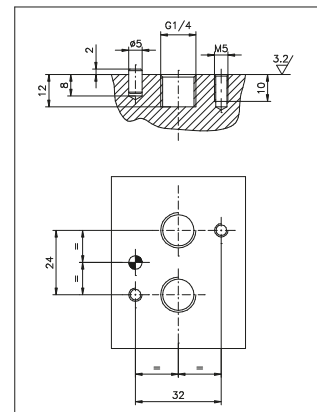
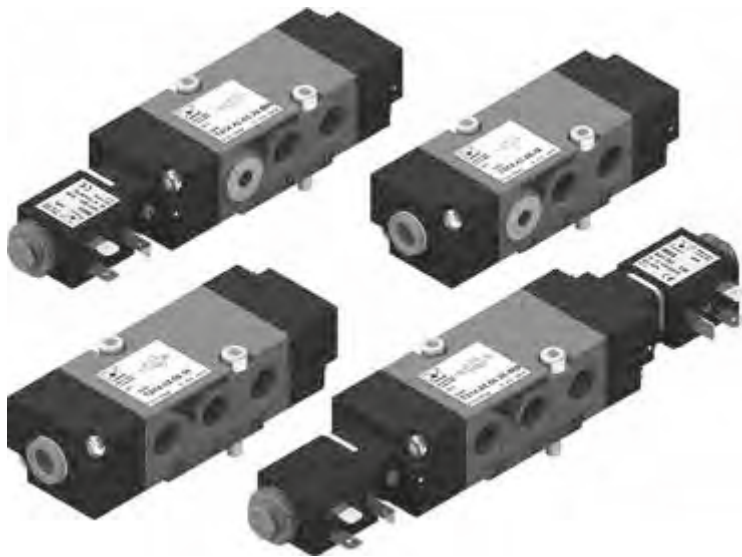

**Pneumatic - Differential**

Coding: T514.Ⓢ.00.16

**Operational characteristics**

Fluid	Filtered air. No lubrication needed, if applied it shall be continuous
Max working pressure (bar)	10
Temperature °C	-10 ÷ +50
Flow rate at 6 bar with Δp=1 (NI/min)	1100
Orifice size (mm)	8
Working ports size	G 1/4"

FUNCTION	
Ⓢ	42 = 4 ways
	52 = 5 ways

4 ways

5 ways

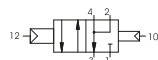
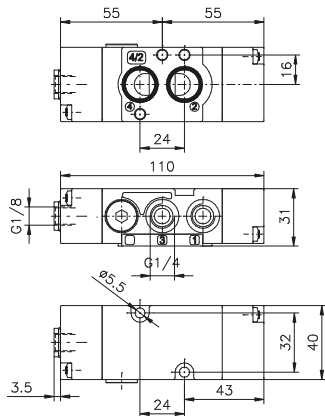

Weight 140 g  
Minimum working pressure 2,5 bar  
Maximum fitting torque 9 N/m

T514.42.00.16

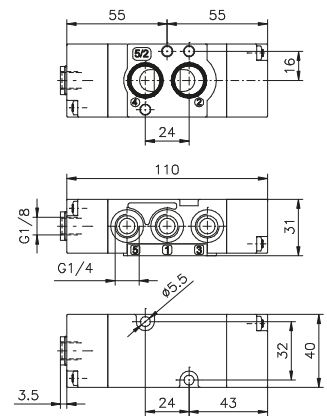

Weight 140 g  
Minimum working pressure 2,5 bar  
Maximum fitting torque 9 N/m

T514.52.00.16

**Pneumatic - Pneumatic**

Coding: T514.Ⓢ.00.18

**Operational characteristics**

Fluid	Filtered air. No lubrication needed, if applied it shall be continuous
Max working pressure (bar)	10
Temperature °C	-10 ÷ +50
Flow rate at 6 bar with Δp=1 (NI/min)	1100
Orifice size (mm)	8
Working ports size	G 1/4"

FUNCTION	
Ⓢ	42 = 4 ways
	52 = 5 ways

4 ways

5 ways

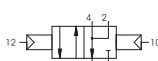
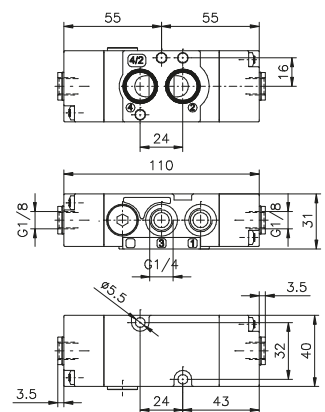

Weight 140 g  
Minimum working pressure 2,5 bar  
Maximum fitting torque 9 N/m

T514.42.00.18

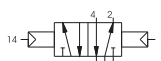
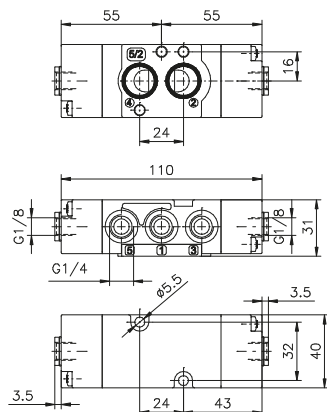

Weight 140 g  
Minimum working pressure 2,5 bar  
Maximum fitting torque 9 N/m

T514.52.00.18



**Pneumatic - Spring**

Coding: T514.F.00.19

Operational characteristics	
Fluid	Filtered air. No lubrication needed, if applied it shall be continuous
Max working pressure (bar)	10
Temperature °C	-10 ÷ +50
Flow rate at 6 bar with Δp=1 (NI/min)	1100
Orifice size (mm)	8
Working ports size	G 1/4"

FUNCTION	
F	42 = 4 ways
	52 = 5 ways

4 ways

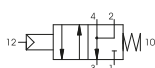
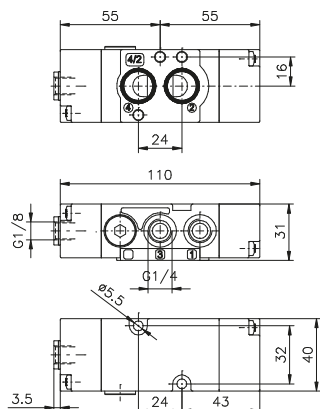

Weight 140 g  
Minimum working pressure 2,5 bar  
Maximum fitting torque 9 N/m

T514.42.00.19

5 ways

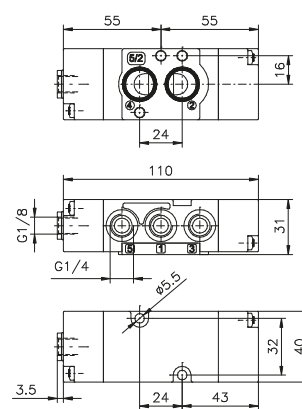

Weight 140 g  
Minimum working pressure 2,5 bar  
Maximum fitting torque 9 N/m

T514.52.00.19

**Solenoid-Solenoid**

Coding: T514.F.00.35.T

Operational characteristics	
Fluid	Filtered air. No lubrication needed, if applied it shall be continuous
Max working pressure (bar)	10
Temperature °C	-10 ÷ +50
Flow rate at 6 bar with Δp=1 (NI/min)	1100
Orifice size (mm)	8
Working ports size	G 1/4"

FUNCTION	
F	42 = 4 ways
	52 = 5 ways

VOLTAGE	
B04	= 12 VDC
B05	= 24 VDC
B09	= 24 VDC (2W)
B56	= 24V (50-60 Hz)
B57	= 110V (50-60 Hz)
B58	= 230 V (50-60 Hz)

4 ways

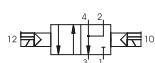
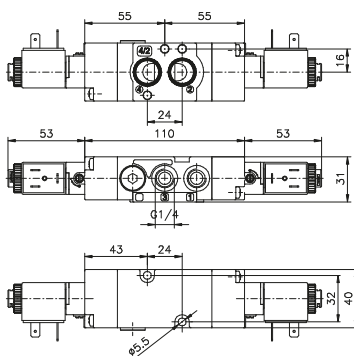

Weight 250 g  
Minimum working pressure 2,5 bar  
Maximum fitting torque 9 N/m

T514.42.00.35.T

5 ways

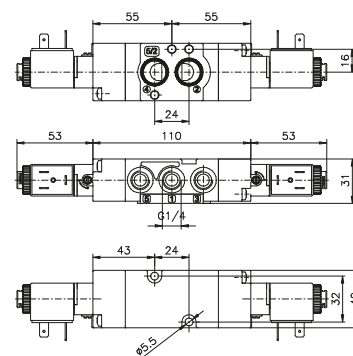

Weight 250 g  
Minimum working pressure 2,5 bar  
Maximum fitting torque 9 N/m

T514.52.00.35.T

**Solenoid-Differential**

Coding: T514.ⓕ.00.36.Ⓡ

**Operational characteristics**

Fluid	Filtered air. No lubrication needed, if applied it shall be continuous
Max working pressure (bar)	10
Temperature °C	-10 ÷ +50
Flow rate at 6 bar with Δp=1 (NI/min)	1100
Orifice size (mm)	8
Working ports size	G 1/4"

ⓕ	FUNCTION	Ⓡ	VOLTAGE
	42 = 4 ways		B04 = 12VDC
	52 = 5 ways		B05 = 24VDC
			B09 = 24VDC (2W)
			B56 = 24V (50-60 Hz)
			B57 = 110V (50-60 Hz)
			B58 = 230V (50-60 Hz)

1  
AIR DISTRIBUTION

4 ways

5 ways

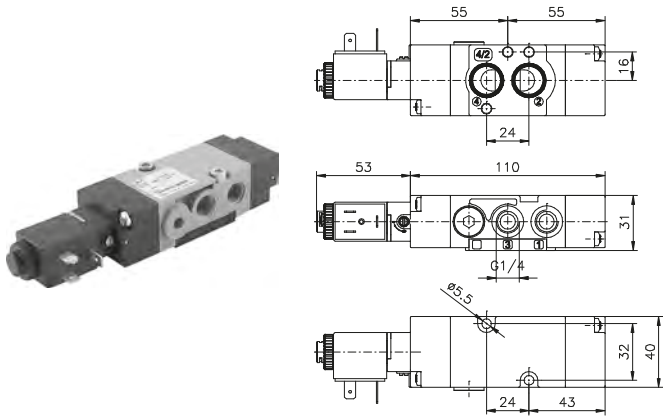

Weight 200 g  
Minimum working pressure 2,5 bar  
Maximum fitting torque 9 N/m

T514.42.00.36.Ⓡ

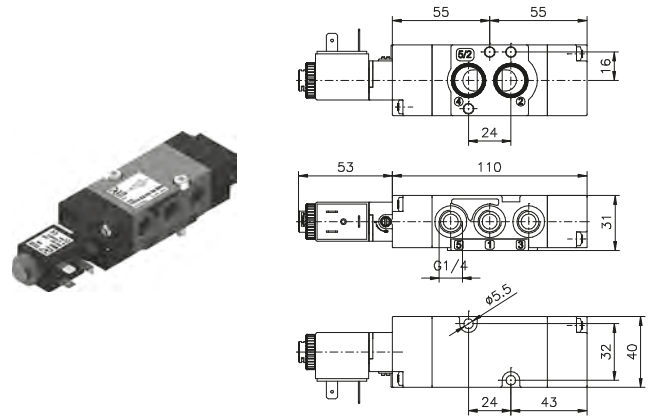
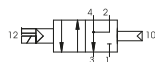

Weight 200 g  
Minimum working pressure 2,5 bar  
Maximum fitting torque 9 N/m

T514.52.00.36.Ⓡ

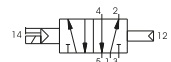

**Solenoid - Spring**

Coding: T514.ⓕ.00.39.Ⓡ

**Operational characteristics**

Fluid	Filtered air. No lubrication needed, if applied it shall be continuous
Max working pressure (bar)	10
Temperature °C	-10 ÷ +50
Flow rate at 6 bar with Δp=1 (NI/min)	1100
Orifice size (mm)	8
Working ports size	G 1/4"

ⓕ	FUNCTION	Ⓡ	VOLTAGE
	42 = 4 ways		B04 = 12VDC
	52 = 5 ways		B05 = 24VDC
			B09 = 24VDC (2W)
			B56 = 24V (50-60 Hz)
			B57 = 110V (50-60 Hz)
			B58 = 230V (50-60 Hz)

4 ways

5 ways

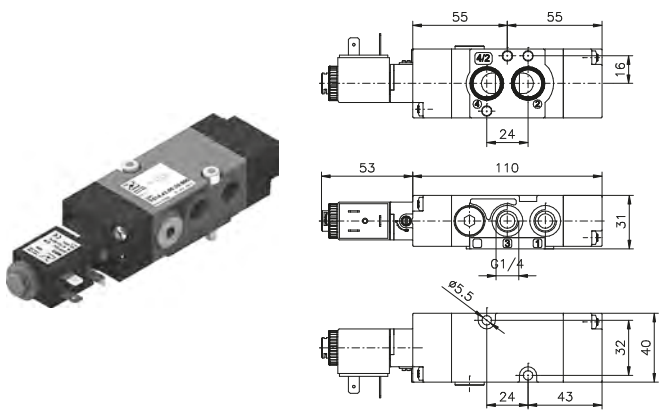

Weight 200 g  
Minimum working pressure 2,5 bar  
Maximum fitting torque 9 N/m

T514.42.00.39.Ⓡ

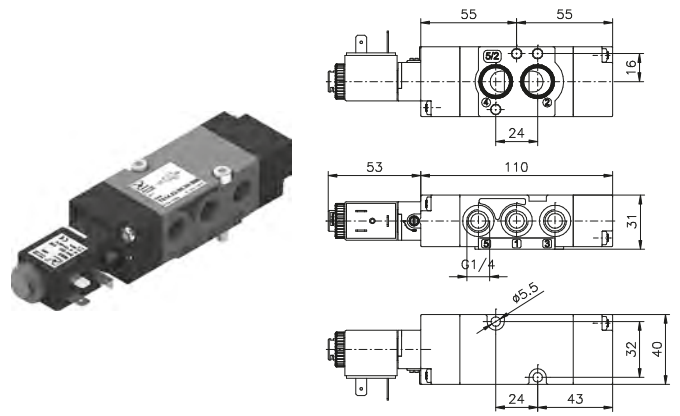
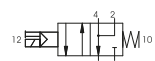

Weight 200 g  
Minimum working pressure 2,5 bar  
Maximum fitting torque 9 N/m

T514.52.00.39.Ⓡ



► **Universal kit**

Coding: T514.92.00.V.T

Operational characteristics	
Fluid	Filtered air. No lubrication needed, if applied it shall be continuous
Max working pressure (bar)	10
Temperature °C	-10 ÷ +50
Flow rate at 6 bar with $\Delta p=1$ (l/min)	1100
Orifice size (mm)	8
Working ports size	G 1/4"

VERSION		VOLTAGE	
16	= Pneumatic - Differential	B04	= 12 VDC
18	= Pneumatic - Pneumatic	B05	= 24 VDC
19	= Pneumatic - Spring	B09	= 24 VDC (2W)
35	= Solenoid - Solenoid	B56	= 24V (50-60 Hz)
36	= Solenoid - Differential	B57	= 110V (50-60 Hz)
39	= Solenoid - Spring	B58	= 230 V (50-60 Hz)



Weight 170 g  
Minimum working pressure 2,5 bar  
Maximum fitting torque 9 N/m

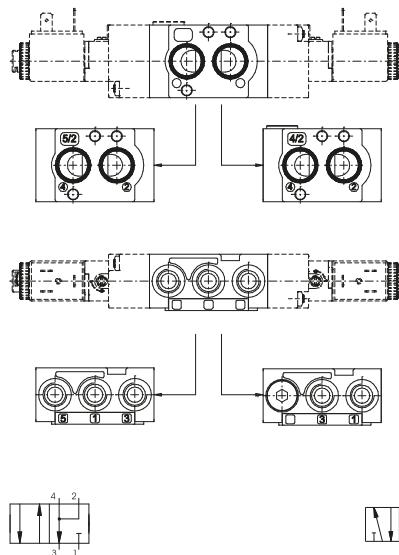

1  
AIR DISTRIBUTION

**Series 514**

**General**

**NAMUR** valves are 5/2 and 4/2 valves and electrovalves, piloted electrically or pneumatically, utilised primarily to operate rotary actuators and wherever there is a NAMUR standard installation plan.

The product is classified for use in potentially explosive atmospheres (Directive 2014/34/EU).

**NAMUR** valves have been developed using the latest, technical design solutions which guarantee flexibility and an increased flow rate capacity exceeding that of traditional, spool valves.

In addition, they have been produced with innovative materials which guarantee increased performance.

**Note:**  
"Although accurately described, the 4/2 valve actually functions as a 3/2 normally closed valve and should be used as such."

**“NAMUR” interface dimensions:**  
according to standard (VDI/VDE 3847 July 2003)

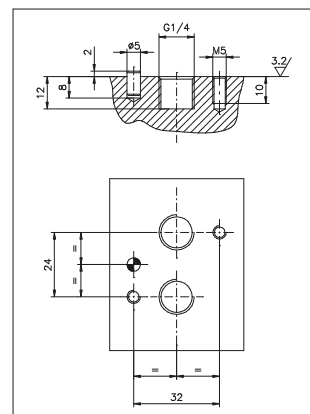
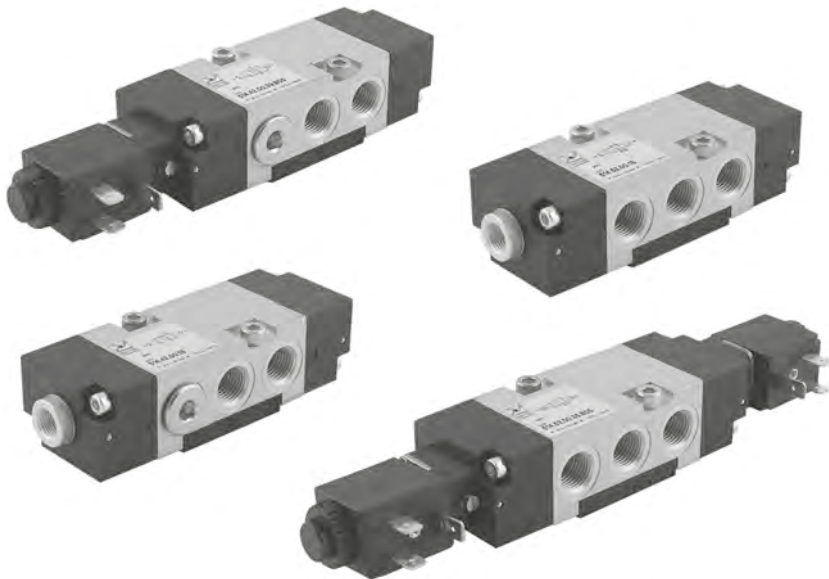

**Construction characteristics**

Body	Aluminium
Spacer	Technopolymer
Seals	Nitrile rubber
Springs	Stainless Steel
Operators	Technopolymer
Spools	Steel
Screws	Zinc coated Steel / Stainless steel

**Certifications available:**

**SOLENOID VALVES WITH XMB OR XMC 3GD COIL**

: CE II 3G Ex h IIB T4 Gc X  
CE II 3D Ex h IIIC T120°C Dc X IP65

**MECHANICAL AND PNEUMATIC VALVES WITHOUT COILS**

: CE II 2G Ex h IIB T5 Gc X  
CE II 2D Ex h IIIC T96°C Dc X IP65

AIR DISTRIBUTION 1

**Pneumatic - Differential**

Coding: **M514.F.00.16**Ⓞ

Operational characteristics	
Fluid	Filtered air. No lubrication needed, if applied it shall be continuous
Max working pressure (bar)	10 Standard valves (-10 ... +50) Low temperature valves (-30 ... +50) ATEX valves (-20 ... +40)
Temperature °C	1100 Standard valves (-10 ... +50) Low temperature valves (-30 ... +50) ATEX valves (-20 ... +40)
Flow rate at 6 bar with Δp=1 (NI/min)	1100
Orifice size (mm)	8
Working ports size	G 1/4"

<b>M</b>	MODEL = Standard valve <b>X</b> = ATEX valve
<b>F</b>	FUNCTION <b>42</b> = 4 ways <b>52</b> = 5 ways
<b>Ⓞ</b>	TEMPERATURE OPTIONS = Standard valves (-10 ... +50) <b>LT</b> = Low temperature valves (-30 ... +50) = ATEX valves (-20 ... +40)

Minimum pilot pressure 2,5 bar  
Maximum fitting torque 9 N/m

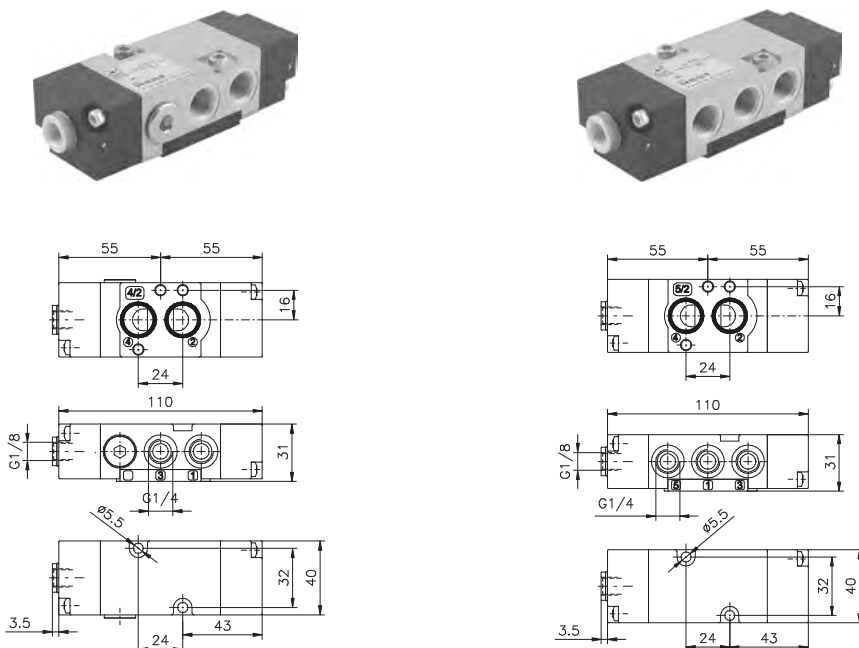

**M514.42.00.16**Ⓞ Weight 240 g

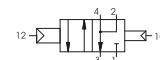

**M514.52.00.16**Ⓞ Weight 235 g



**Pneumatic - Pneumatic**

Coding: **M514.F.00.18**Ⓞ

Operational characteristics	
Fluid	Filtered air. No lubrication needed, if applied it shall be continuous
Max working pressure (bar)	10 Standard valves (-10 ... +50) Low temperature valves (-30 ... +50) ATEX valves (-20 ... +40)
Temperature °C	1100 Standard valves (-10 ... +50) Low temperature valves (-30 ... +50) ATEX valves (-20 ... +40)
Flow rate at 6 bar with Δp=1 (NI/min)	1100
Orifice size (mm)	8
Working ports size	G 1/4"

<b>M</b>	MODEL = Standard valve <b>X</b> = ATEX valve
<b>F</b>	FUNCTION <b>42</b> = 4 ways <b>52</b> = 5 ways
<b>Ⓞ</b>	TEMPERATURE OPTIONS = Standard valves (-10 ... +50) <b>LT</b> = Low temperature valves (-30 ... +50) = ATEX valves (-20 ... +40)

Minimum pilot pressure 2,5 bar  
Maximum fitting torque 9 N/m

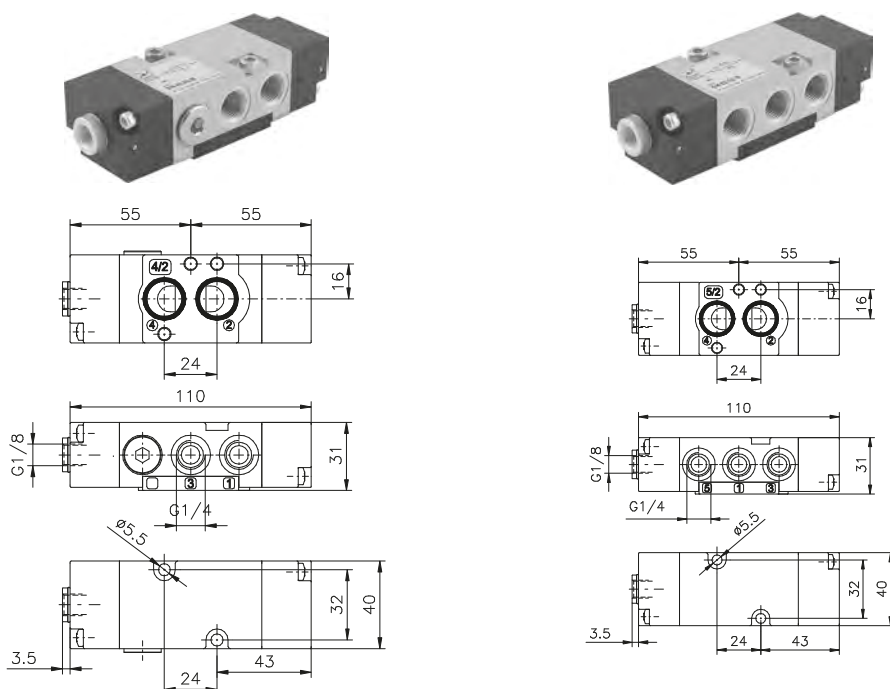

**M514.42.00.18**Ⓞ Weight 240 g

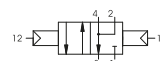

**M514.52.00.18**Ⓞ Weight 235 g

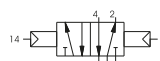



Pneumatic - Spring

Coding: M514.F.00.19O

Operational characteristics

Fluid	Filtered air. No lubrication needed, if applied it shall be continuous
Max working pressure (bar)	10
Temperature °C	Standard valves (-10 ... +50) Low temperature valves (-30 ... +50) ATEX valves (-20 ... +40)
Flow rate at 6 bar with $\Delta p=1$ (NI/min)	1100
Orifice size (mm)	8
Working ports size	G 1/4"

MODEL	M = Standard valve X = ATEX valve
FUNCTION	F 42 = 4 ways 52 = 5 ways
TEMPERATURE OPTIONS	O = Standard valves (-10 ... +50) LT = Low temperature valves (-30 ... +50) = ATEX valves (-20 ... +40)

Minimum pilot pressure 2,5 bar  
Maximum fitting torque 9 N/m

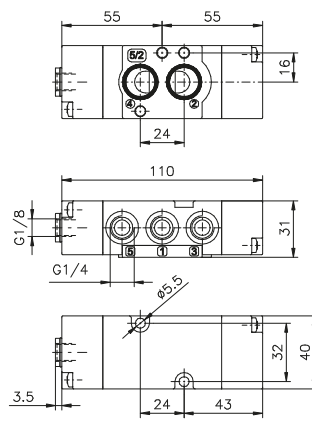
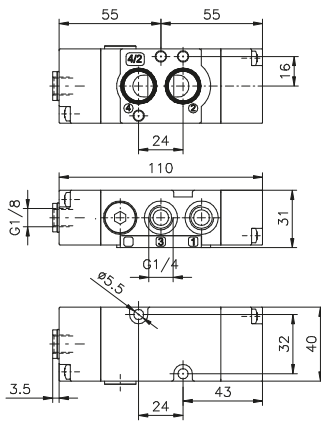

M514.42.00.19O Weight 240 g

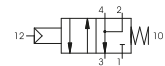

M514.52.00.19O Weight 235 g

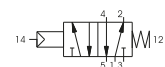

1 AIR DISTRIBUTION



Solenoid-Solenoid

Coding: M514.F.00.35.T.O

Operational characteristics	
Fluid	Filtered air. No lubrication needed, if applied it shall be continuous
Max working pressure (bar)	10
Temperature °C	Standard valves (-10 ... +50) Low temperature valves (-30 ... +50) ATEX valves (-20 ... +40)
Flow rate at 6 bar with Δp=1 (NI/min)	1100
Orifice size (mm)	8
Working ports size	G 1/4"

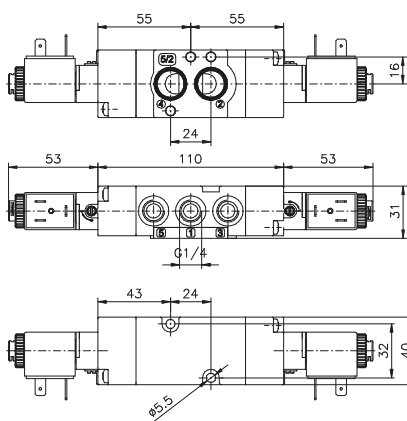
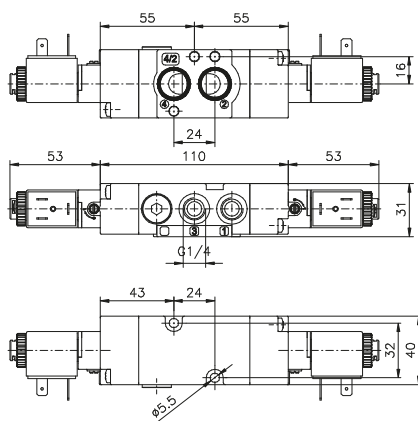

MODEL	
M	= Standard valve
X	= ATEX valve
FUNCTION	
F	42 = 4 ways
52	= 5 ways
VOLTAGE	
B04	= 12 VDC
B05	= 24 VDC
B09	= 24 VDC (2W)
B56	= 24V (50-60 Hz)
B57	= 110V (50-60 Hz)
B58	= 230 V (50-60 Hz)
C04	= 12 VDC
C05	= 24 VDC
T	
C09	= 24 VDC (2W)
C56	= 24 V (50-60 Hz)
C57	= 110 V (50-60 Hz)
C58	= 230 V (50-60 Hz)
F04	= 12 VDC
F05	= 24 VDC
F56	= 24 V (50-60 Hz)
F57	= 110 V (50-60 Hz)
F58	= 230 V (50-60 Hz)
TEMPERATURE OPTIONS	
	= Standard valves (-10 ... +50)
LT	= Low temperature valves (-30 ... +50)
O	= ATEX valves (-20 ... +40)

Minimum pilot pressure 2,5 bar  
Maximum fitting torque 9 N/m  
“LT” and “ATEX” versions are not available with MF coils

M514.42.00.35.O Weight 410 g



M514.52.00.35.O Weight 405 g

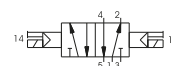

1  
AIR DISTRIBUTION

**Solenoid-Differential**

Coding: **M**514.**F**.00.36**T****⊙**

Operational characteristics	
Fluid	Filtered air. No lubrication needed, if applied it shall be continuous
Max working pressure (bar)	10
Temperature °C	Standard valves (-10 ... +50) Low temperature valves (-30 ... +50) ATEX valves (-20 ... +40)
Flow rate at 6 bar with $\Delta p=1$ (NI/min)	1100
Orifice size (mm)	8
Working ports size	G 1/4"

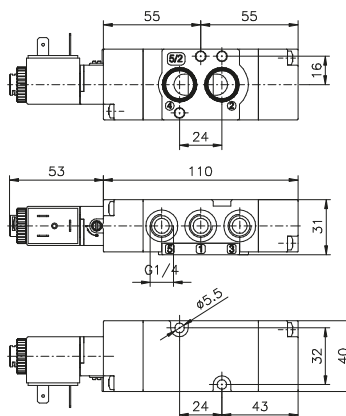
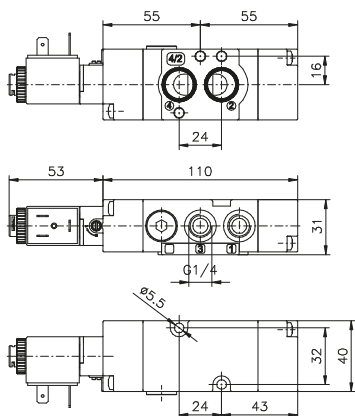

<b>M</b>	MODEL
	= Standard valve
	<b>X</b> = ATEX valve
<b>F</b>	FUNCTION
	<b>42</b> = 4 ways
	<b>52</b> = 5 ways
	VOLTAGE
	<b>B04</b> = 12 VDC
	<b>B05</b> = 24 VDC
	<b>B09</b> = 24 VDC (2W)
	<b>B56</b> = 24V (50-60 Hz)
	<b>B57</b> = 110V (50-60 Hz)
	<b>B58</b> = 230 V (50-60 Hz)
	<b>C04</b> = 12 VDC
	<b>C05</b> = 24 VDC
<b>T</b>	<b>C09</b> = 24 VDC (2W)
	<b>C56</b> = 24 V (50-60 Hz)
	<b>C57</b> = 110 V (50-60 Hz)
	<b>C58</b> = 230 V (50-60 Hz)
	<b>F04</b> = 12 VDC
	<b>F05</b> = 24 VDC
	<b>F56</b> = 24 V (50-60 Hz)
	<b>F57</b> = 110 V (50-60 Hz)
	<b>F58</b> = 230 V (50-60 Hz)
	TEMPERATURE OPTIONS
	= Standard valves (-10 ... +50)
<b>⊙</b>	<b>LT</b> = Low temperature valves (-30 ... +50)
	= ATEX valves (-20 ... +40)

Minimum pilot pressure 2.5 bar  
Maximum fitting torque 9 N/m  
“LT” and “ATEX” versions are not available with MF coils

**M**514.42.00.36**T****⊙** Weight 330 g

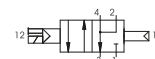

**M**514.52.00.36**T****⊙** Weight 325 g

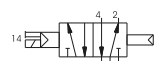

1 AIR DISTRIBUTION

Solenoid - Spring

Coding: M514.F.00.39.T.O

Operational characteristics	
Fluid	Filtered air. No lubrication needed, if applied it shall be continuous
Max working pressure (bar)	10
Temperature °C	Standard valves (-10 ... +50) Low temperature valves (-30 ... +50) ATEX valves (-20 ... +40)
Flow rate at 6 bar with Δp=1 (NI/min)	1100
Orifice size (mm)	8
Working ports size	G 1/4"

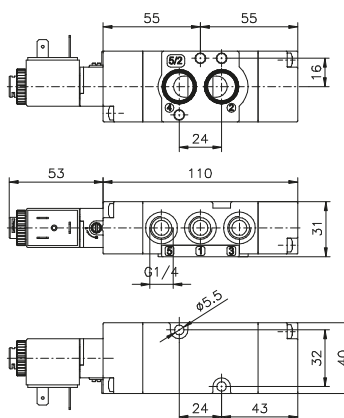
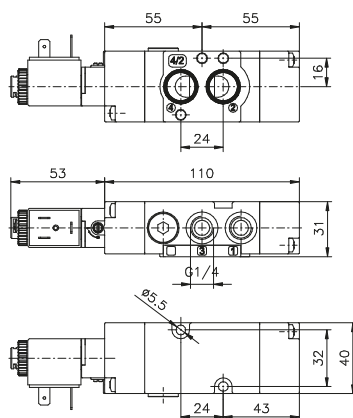

MODEL	
M	= Standard valve
X	= ATEX valve
FUNCTION	
F	42 = 4 ways
52 = 5 ways	
VOLTAGE	
B04 =	12 VDC
B05 =	24 VDC
B09 =	24 VDC (2W)
B56 =	24V (50-60 Hz)
B57 =	110V (50-60 Hz)
B58 =	230 V (50-60 Hz)
C04 =	12 VDC
C05 =	24 VDC
T	
C09 =	24 VDC (2W)
C56 =	24 V (50-60 Hz)
C57 =	110 V (50-60 Hz)
C58 =	230 V (50-60 Hz)
F04 =	12 VDC
F05 =	24 VDC
F56 =	24 V (50-60 Hz)
F57 =	110 V (50-60 Hz)
F58 =	230 V (50-60 Hz)
TEMPERATURE OPTIONS	
	= Standard valves (-10 ... +50)
LT	= Low temperature valves (-30 ... +50)
⊙	= ATEX valves (-20 ... +40)

Minimum pilot pressure 2,5 bar  
Maximum fitting torque 9 N/m  
"LT" and "ATEX" versions are not available with MF coils

M514.42.00.39.T.⊙ Weight 330 g

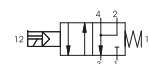

M514.52.00.39.T.⊙ Weight 325 g

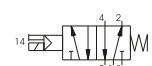

1 AIR DISTRIBUTION

**Universal kit**

**Operational characteristics**

Fluid	Filtered air. No lubrication needed, if applied it shall be continuous
Max working pressure (bar)	10
Temperature °C	Standard valves (-10 ... +50) Low temperature valves (-30 ... +50) ATEX valves (-20 ... +40)
Flow rate at 6 bar with $\Delta p=1$ (NI/min)	1100
Orifice size (mm)	8
Working ports size	G 1/4"

<b>M</b>	MODEL
	= Standard valve
	<b>X</b> = ATEX valve
	VERSION
	<b>16</b> = Pneumatic - Differential
	<b>18</b> = Pneumatic - Pneumatic
<b>V</b>	<b>19</b> = Pneumatic - Spring
	<b>35</b> = Solenoid - Solenoid
	<b>36</b> = Solenoid - Differential
	<b>39</b> = Solenoid - Spring
	VOLTAGE
	<b>B04</b> = 12 VDC
	<b>B05</b> = 24 VDC
	<b>B09</b> = 24 VDC (2W)
	<b>B56</b> = 24V (50-60 Hz)
	<b>B57</b> = 110V (50-60 Hz)
	<b>B58</b> = 230V (50-60 Hz)
	<b>C04</b> = 12 VDC
	<b>C05</b> = 24 VDC
<b>T</b>	<b>C09</b> = 24 VDC (2W)
	<b>C56</b> = 24 V (50-60 Hz)
	<b>C57</b> = 110 V (50-60 Hz)
	<b>C58</b> = 230 V (50-60 Hz)
	<b>F04</b> = 12 VDC
	<b>F05</b> = 24 VDC
	<b>F56</b> = 24 V (50-60 Hz)
	<b>F57</b> = 110 V (50-60 Hz)
	<b>F58</b> = 230 V (50-60 Hz)
	TEMPERATURE OPTIONS
	= Standard valves (-10 ... +50)
<b>O</b>	<b>LT</b> = Low temperature valves (-30 ... +50)
	= ATEX valves (-20 ... +40)

Minimum pilot pressure 2,5 bar  
Maximum fitting torque 9 N/m  
“LT” and “ATEX” versions are not available with MF coils

To change a 5/2 valve into a 4/2:  
Simply replace the bottom plate with the one included in the universal kit (cod. 514.92....) and by plugging port 5

Weight 405 g

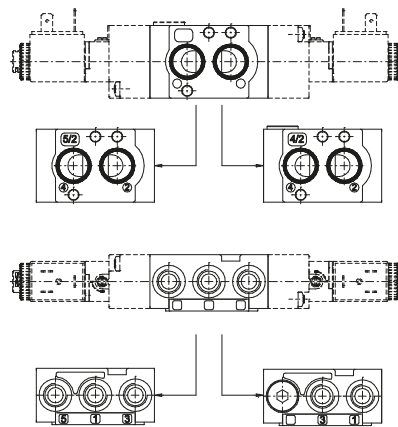

1 AIR DISTRIBUTION

## Series 515

### General

**NAMUR** valves are 5/2 and 4/2 valves and electrovalves, piloted electrically or pneumatically, utilised primarily to operate rotary actuators and wherever there is a **NAMUR** standard installation plan.

The product is classified for use in potentially explosive atmospheres (Directive 2014/34/EU).

**NAMUR** valves have been developed using the latest, technical design solutions which guarantee flexibility and an increased flow rate capacity exceeding that of traditional, spool valves.

In addition, they have been produced with innovative materials which guarantee increased performance.

### IMPORTANT:

Differs from version 514 because it is supplied without a plate.

“NAMUR” interface dimensions:  
according to standard (VDI/VDE 3847 July 2003)

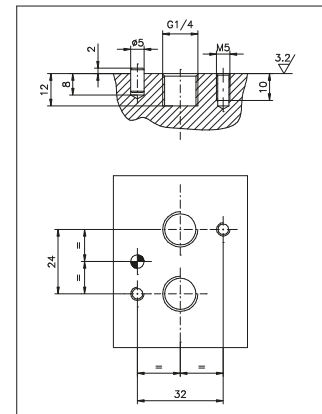

1  
AIR DISTRIBUTION

### Construction characteristics

Body	Aluminium
Spacer	Technopolymer
Seals	Nitrile rubber
Springs	Stainless Steel
Operators	Technopolymer
Spools	Steel
Screws	Zinc coated Steel / Stainless steel

### Certifications available:

#### SOLENOID VALVES WITH XMB OR XMC 3GD COIL

: CE II 3G Ex h IIB T4 Gc X  
CE II 3D Ex h IIIC T120°C Dc X IP65

#### MECHANICAL AND PNEUMATIC VALVES WITHOUT COILS

: CE II 2G Ex h IIB T5 Gc X  
CE II 2D Ex h IIIC T96°C Dc X IP65



**Pneumatic - Differential**

Coding: **M515.52.00.16**

**Operational characteristics**

Fluid	Filtered air. No lubrication needed, if applied it shall be continuous
Max working pressure (bar)	10
Temperature °C	Standard valves (-10 ... +50) Low temperature valves (-30 ... +50) ATEX valves (-20 ... +40)
Flow rate at 6 bar with $\Delta p=1$ (NI/min)	1100
Orifice size (mm)	8
Working ports size	G 1/4"

<b>M</b>	MODEL	<b>⊙</b>	TEMPERATURE OPTIONS
	= Standard valve		= Standard valves (-10 ... +50)
	X = ATEX valve		LT = Low temperature valves (-30 ... +50)
			= ATEX valves (-20 ... +40)

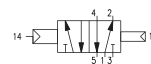
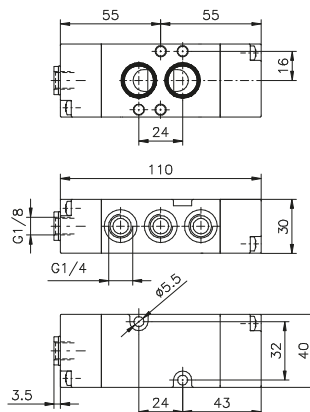

Weight 245 g  
Minimum pilot pressure 2,5 bar  
Maximum fitting torque 9 N/m

**Pneumatic - Pneumatic**

Coding: **M515.52.00.18**

**Operational characteristics**

Fluid	Filtered air. No lubrication needed, if applied it shall be continuous
Max working pressure (bar)	10
Temperature °C	Standard valves (-10 ... +50) Low temperature valves (-30 ... +50) ATEX valves (-20 ... +40)
Flow rate at 6 bar with $\Delta p=1$ (NI/min)	1100
Orifice size (mm)	8
Working ports size	G 1/4"

<b>M</b>	MODEL	<b>⊙</b>	TEMPERATURE OPTIONS
	= Standard valve		= Standard valves (-10 ... +50)
	X = ATEX valve		LT = Low temperature valves (-30 ... +50)
			= ATEX valves (-20 ... +40)

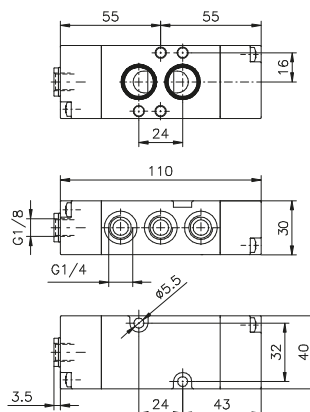

Weight 245 g  
Minimum pilot pressure 2,5 bar  
Maximum fitting torque 9 N/m

1 AIR DISTRIBUTION



**Pneumatic - Spring**

Coding: **M**515.52.00.19**Ⓞ**

Operational characteristics	
Fluid	Filtered air. No lubrication needed, if applied it shall be continuous
Max working pressure (bar)	10
Temperature °C	Standard valves (-10 ... +50) Low temperature valves (-30 ... +50) ATEX valves (-20 ... +40)
Flow rate at 6 bar with Δp=1 (NI/min)	1100
Orifice size (mm)	8
Working ports size	G 1/4"

MODEL	TEMPERATURE OPTIONS
<b>M</b> = Standard valve	<b>Ⓞ</b> = Standard valves (-10 ... +50)
<b>X</b> = ATEX valve	<b>LT</b> = Low temperature valves (-30 ... +50)
	= ATEX valves (-20 ... +40)



Weight 245 g  
Minimum pilot pressure 2,5 bar  
Maximum fitting torque 9 N/m

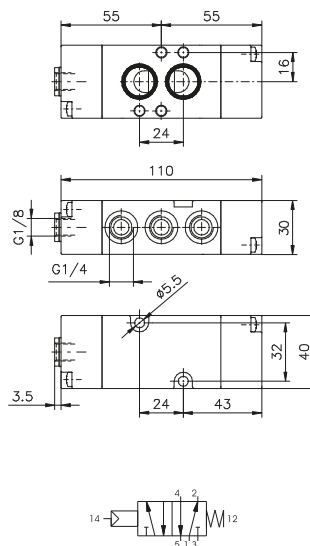

1  
AIR DISTRIBUTION

**Solenoid-Solenoid**

Coding: **M**515.52.00.35.**T****C**

**Operational characteristics**

Fluid	Filtered air. No lubrication needed, if applied it shall be continuous
Max working pressure (bar)	10
Temperature °C	Standard valves (-10 ... +50) Low temperature valves (-30 ... +50) ATEX valves (-20 ... +40)
Flow rate at 6 bar with Δp=1 (NI/min)	1100
Orifice size (mm)	8
Working ports size	G 1/4"

<b>M</b>	MODEL - = Standard valve <b>X</b> = ATEX valve	<b>C</b>	TEMPERATURE OPTIONS = Standard valves (-10 ... +50) <b>LT</b> = Low temperature valves (-30 ... +50) = ATEX valves (-20 ... +40)
<b>T</b>	VOLTAGE <b>B04</b> = 12 VDC <b>B05</b> = 24 VDC <b>B09</b> = 24 VDC (2W) <b>B56</b> = 24V (50-60 Hz) <b>B57</b> = 110V (50-60 Hz) <b>B58</b> = 230 V (50-60 Hz) <b>C04</b> = 12 VDC <b>C05</b> = 24 VDC <b>C09</b> = 24 VDC (2W) <b>C56</b> = 24 V (50-60 Hz) <b>C57</b> = 110 V (50-60 Hz) <b>C58</b> = 230 V (50-60 Hz) <b>F04</b> = 12 VDC <b>F05</b> = 24 VDC <b>F56</b> = 24 V (50-60 Hz) <b>F57</b> = 110 V (50-60 Hz) <b>F58</b> = 230 V (50-60 Hz)		

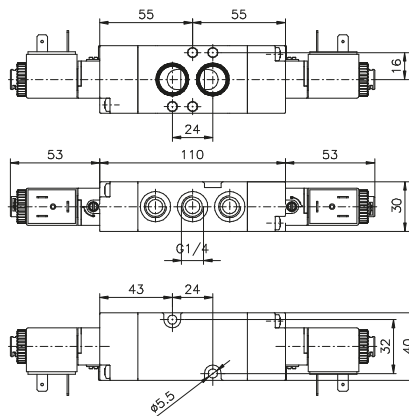

Weight 415 g  
Minimum pilot pressure 2,5 bar  
Maximum fitting torque 9 N/m



1 AIR DISTRIBUTION





**Solenoid-Differential**

Coding: M515.52.00.36.T.O

Operational characteristics	
Fluid	Filtered air. No lubrication needed, if applied it shall be continuous
Max working pressure (bar)	10
Temperature °C	Standard valves (-10 ... +50) Low temperature valves (-30 ... +50) ATEX valves (-20 ... +40)
Flow rate at 6 bar with Δp=1 (NI/min)	1100
Orifice size (mm)	8
Working ports size	G 1/4"

M	MODEL -	O	TEMPERATURE OPTIONS
	= Standard valve		= Standard valves (-10 ... +50)
	X = ATEX valve		LT = Low temperature valves (-30 ... +50)
VOLTAGE		= ATEX valves (-20 ... +40)	
	B04 = 12 VDC		
	B05 = 24 VDC		
	B09 = 24 VDC (2W)		
	B56 = 24V (50-60 Hz)		
	B57 = 110V (50-60 Hz)		
	B58 = 230 V (50-60 Hz)		
	C04 = 12 VDC		
	C05 = 24 VDC		
T	C09 = 24 VDC (2W)		
	C56 = 24 V (50-60 Hz)		
	C57 = 110 V (50-60 Hz)		
	C58 = 230 V (50-60 Hz)		
	F04 = 12 VDC		
	F05 = 24 VDC		
	F56 = 24 V (50-60 Hz)		
	F57 = 110 V (50-60 Hz)		
	F58 = 230 V (50-60 Hz)		

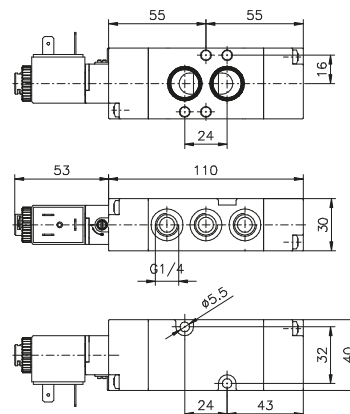

Weight 330 g  
Minimum pilot pressure 2,5 bar  
Maximum fitting torque 9 N/m

1 AIR DISTRIBUTION



Solenoid - Spring

Coding: M515.52.00.39.TO

Operational characteristics

Fluid	Filtered air. No lubrication needed, if applied it shall be continuous
Max working pressure (bar)	10
Temperature °C	Standard valves (-10 ... +50) Low temperature valves (-30 ... +50) ATEX valves (-20 ... +40)
Flow rate at 6 bar with $\Delta p=1$ (NI/min)	1100
Orifice size (mm)	8
Working ports size	G 1/4"

M	MODEL	C	TEMPERATURE OPTIONS
	= Standard valve		= Standard valves (-10 ... +50)
	X = ATEX valve		LT = Low temperature valves (-30 ... +50)
	VOLTAGE		= ATEX valves (-20 ... +40)
	B04 = 12 VDC		
	B05 = 24 VDC		
	B09 = 24 VDC (2W)		
	B56 = 24V (50-60 Hz)		
	B57 = 110V (50-60 Hz)		
	B58 = 230 V (50-60 Hz)		
	C04 = 12 VDC		
	C05 = 24 VDC		
T	C09 = 24 VDC (2W)		
	C56 = 24 V (50-60 Hz)		
	C57 = 110 V (50-60 Hz)		
	C58 = 230 V (50-60 Hz)		
	F04 = 12 VDC		
	F05 = 24 VDC		
	F56 = 24 V (50-60 Hz)		
	F57 = 110 V (50-60 Hz)		
	F58 = 230 V (50-60 Hz)		

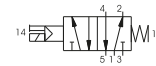
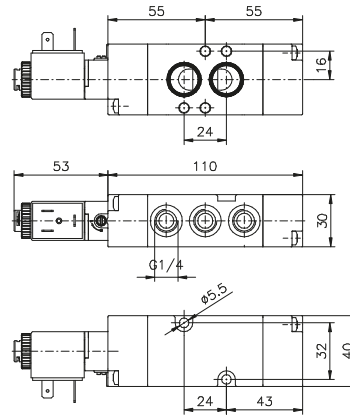

Weight 330 g  
Minimum pilot pressure 2,5 bar  
Maximum fitting torque 9 N/m

AIR DISTRIBUTION

1



## Series 1000 - Size 1, 2 & 3

### General

5 ways 2 or 3 positions distributors and electric distributors can be used mounted on individual or ganged bases. These standards are ISO 5599/1, according to which certain dimensions are mandatory, namely, the mounting surface, the pitch of the fastening screws, the characteristic of the electric pilot, the flow rate, the pneumatic connections, and so on.

The design is based on the balanced spool principle with pneumatic or electropneumatic actuators and resetting by mechanically or pneumatically operated spring.

The 3 position closed centres, are obtained by spring operation.

The feed to the actuators on the distributors can be provided either by pressure intake from inlet 1 (autofeed) or through the base from inlets 12 and 14 (external feed); there are two separate types of these distributors: one is the Series 1000 and the other is the Series 1010.

The Serie 1000 includes size 1 and 2 and are built of die-cast aluminium. The selection is made by turning a seal fitted between body and operator by 180°, so to utilize external-feed pilot or with internal feed.

**Ordering codes are referring to distributors with "M2" mechanics or solenoid valves "S" mounted.**

**Coil are not included and have to be ordered separately (see Series 300).**

**"S" homologated c RU us solenoid coil are available (see Series 300).**

### Use and maintenance

This valves have an average life of 15 million cycles depending on the application and air quality.

Filtered and lubricated air using specified lubricants will reduce the wear of the seals and ensures long and trouble free operation.

Make sure that the conditions of use comply with the pressure, temperature etc. limits indicated and that the fastening screws are tightened with the following maximum torques on distributors Serie 1010.

**Size 1 = 4 Nm**

**Size 2 = 5 Nm**

**Size 3 = 8 Nm**

Repair kits including the spool complete with seals are available for overhauling the valves.

However, although this is a simple operation it should be carried out by a competent person.

**ATTENTION:** use hydraulic oil class H for lubrication such as MAGNA GC 32 (Castrol).

### Construction characteristics

Series 1000	Size 1	Size 2
Body	Zinc alloy	Aluminium
Operators	Zinc alloy	Aluminium
Spools	Steel	Steel
Seals	NBR	NBR
Spacer	Technopolymer	Aluminium
Springs	Spring steel	Spring steel
Selectors	NBR	NBR

  

Series 1010	Size 1	Size 2	Size 3
Body	Technopolymer	Technopolymer	Aluminium
Operators	Technopolymer	Technopolymer	Aluminium
Spools	Steel	Steel	Steel
Seals	NBR	NBR	NBR
Spacer	Technopolymer	Technopolymer	Technopolymer
Pistons	Aluminium	Aluminium	Aluminium
Springs	Spring steel	Spring steel	Spring steel

**Pneumatic - Spring**

Coding: 1001.52.1.9

Operational characteristics	
Fluid	Filtered air. No lubrication needed, if applied it shall be continuous
Max working pressure (bar)	10
Temperature °C	-5 ÷ +70
Flow rate at 6 bar with $\Delta p=1$ (NI/min)	840

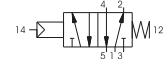
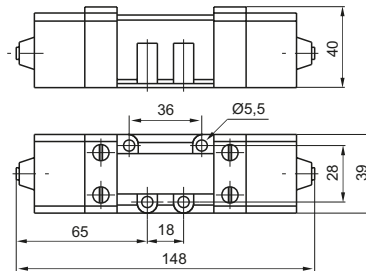

Weight 780 g  
Minimum piloting pressure 2,5 bar

**Pneumatic - Differential**

Coding: 1001.52.1.6

Operational characteristics	
Fluid	Filtered air. No lubrication needed, if applied it shall be continuous
Max working pressure (bar)	10
Temperature °C	-5 ÷ +70
Flow rate at 6 bar with $\Delta p=1$ (NI/min)	840

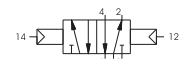
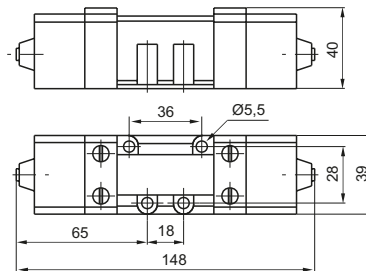

Weight 790 g  
Minimum piloting pressure 2 bar

**Pneumatic-Pneumatic 5/2**

Coding: 1001.52.1.8

Operational characteristics	
Fluid	Filtered air. No lubrication needed, if applied it shall be continuous
Max working pressure (bar)	10
Temperature °C	-5 ÷ +70
Flow rate at 6 bar with $\Delta p=1$ (NI/min)	840

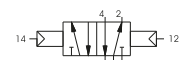
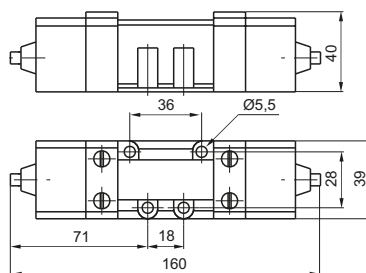

Weight 800 g  
Minimum piloting pressure 1,5 bar

**Pneumatic-Pneumatic 5/3**

Coding: 1001.53.1.8

Operational characteristics	
Fluid	Filtered air. No lubrication needed, if applied it shall be continuous
Max working pressure (bar)	10
Temperature °C	-5 ÷ +70
Flow rate at 6 bar with $\Delta p=1$ (NI/min)	720

FUNCTION	
<b>F</b> 31	= Closed centres
<b>F</b> 32	= Open centres
<b>F</b> 33	= Pressured centres

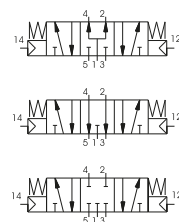
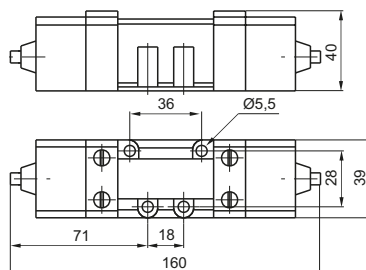

Weight 800 g  
Minimum piloting pressure 3 bar

**Solenoid - Spring**

Coding: 1051.52.3.9.M2

Operational characteristics	
Fluid	Filtered air. No lubrication needed, if applied it shall be continuous
Max working pressure (bar)	10
Temperature °C	-5 ÷ +50
Flow rate at 6 bar with Δp=1 (NI/min)	840

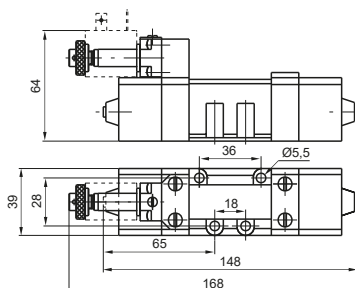
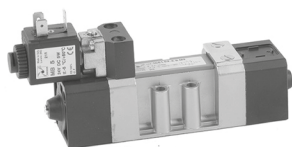

Weight 890 g  
Minimum piloting pressure 2,5 bar

**Solenoid-Differential**

Coding: 1051.52.3.6.M2

Operational characteristics	
Fluid	Filtered air. No lubrication needed, if applied it shall be continuous
Max working pressure (bar)	10
Temperature °C	-5 ÷ +50
Flow rate at 6 bar with Δp=1 (NI/min)	840

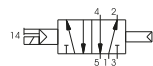
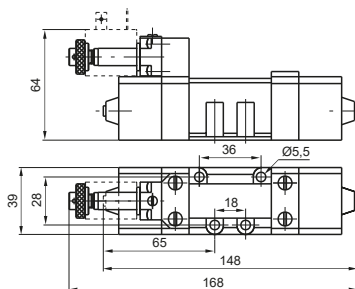
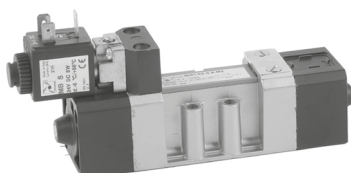

Weight 900 g  
Minimum piloting pressure 2 bar

**Solenoid-Solenoid 5/2**

Coding: 1051.52.3.5.M2

Operational characteristics	
Fluid	Filtered air. No lubrication needed, if applied it shall be continuous
Max working pressure (bar)	10
Temperature °C	-5 ÷ +50
Flow rate at 6 bar with Δp=1 (NI/min)	840

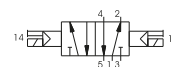
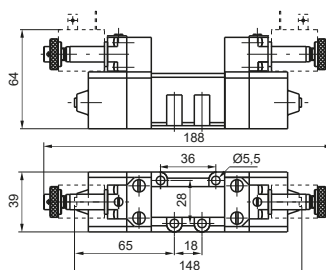
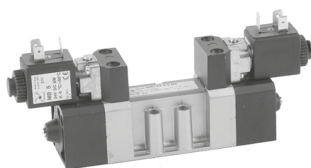

Weight 1040 g  
Minimum piloting pressure 1,5 bar

**Solenoid-Solenoid 5/3**

Coding: 1051.53.F.3.5.M2

Operational characteristics	
Fluid	Filtered air. No lubrication needed, if applied it shall be continuous
Max working pressure (bar)	10
Temperature °C	-5 ÷ +50
Flow rate at 6 bar with Δp=1 (NI/min)	720

FUNCTION
F 31 = Closed centres
32 = Open centres
33 = Pressured centres

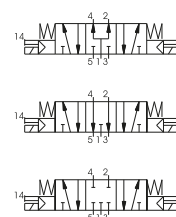
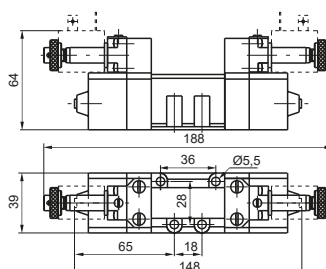
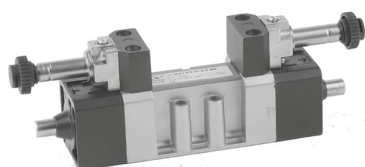

Weight 1040 g  
Minimum piloting pressure 3 bar

**Pneumatic - Differential**

Coding: 1002.52.1.6

Operational characteristics	
Fluid	Filtered air. No lubrication needed, if applied it shall be continuous
Max working pressure (bar)	10
Temperature °C	-5 ÷ +70
Flow rate at 6 bar with Δp=1 (NI/min)	1700

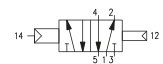
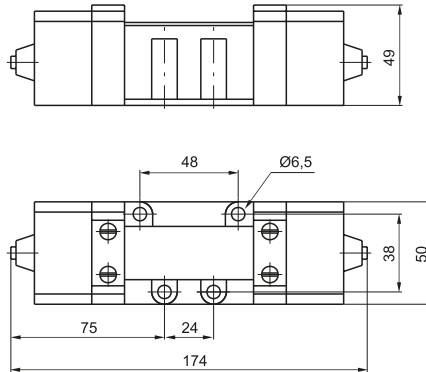

Weight 730 g  
Minimum piloting pressure 2 bar

**Pneumatic-Pneumatic 5/2**

Coding: 1002.52.1.8

Operational characteristics	
Fluid	Filtered air. No lubrication needed, if applied it shall be continuous
Max working pressure (bar)	10
Temperature °C	-5 ÷ +70
Flow rate at 6 bar with Δp=1 (NI/min)	1700

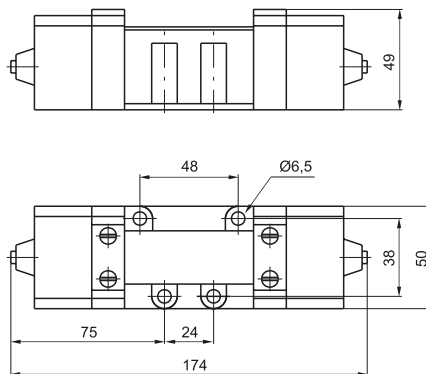
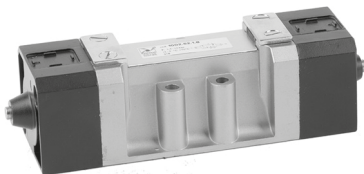

Weight 800 g  
Minimum piloting pressure 1,5 bar

**Pneumatic-Pneumatic 5/3**

Coding: 1002.53.1.8

Operational characteristics	
Fluid	Filtered air. No lubrication needed, if applied it shall be continuous
Max working pressure (bar)	10
Temperature °C	-5 ÷ +70
Flow rate at 6 bar with Δp=1 (NI/min)	1700

FUNCTION	
<b>F</b> 31	= Closed centres
32	= Open centres
33	= Pressured centres

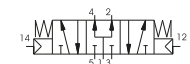
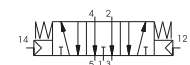
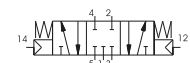
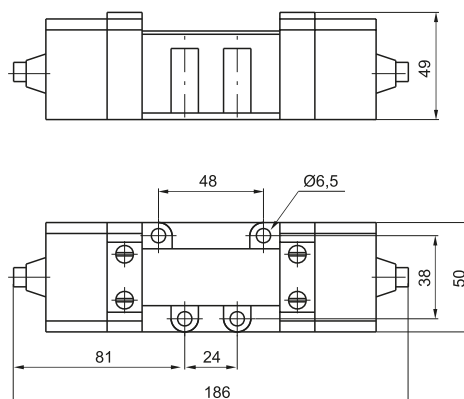

Weight 740 g  
Minimum piloting pressure 3 bar

**Solenoid-Differential**

Coding: 1052.52.3.6.M2

Operational characteristics	
Fluid	Filtered air. No lubrication needed, if applied it shall be continuous
Max working pressure (bar)	10
Temperature °C	-5 ÷ +50
Flow rate at 6 bar with $\Delta p=1$ (NI/min)	1700

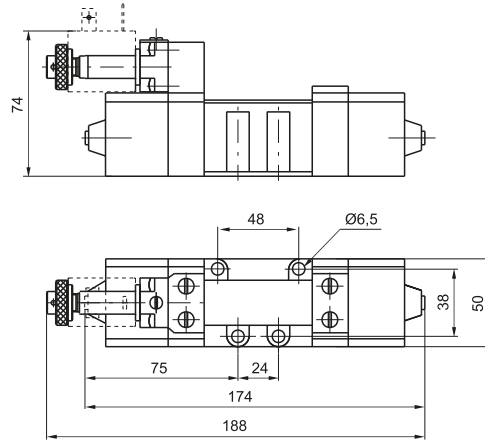

Weight 850 g  
Minimum piloting pressure 2 bar

**Solenoid-Solenoid 5/2**

Coding: 1052.52.3.5.M2

Operational characteristics	
Fluid	Filtered air. No lubrication needed, if applied it shall be continuous
Max working pressure (bar)	10
Temperature °C	-5 ÷ +50
Flow rate at 6 bar with $\Delta p=1$ (NI/min)	1700

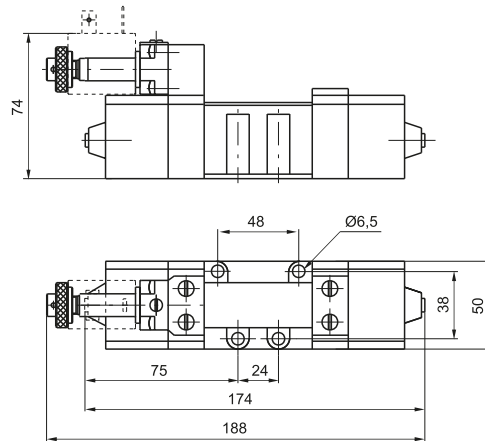

Weight 980 g  
Minimum piloting pressure 1,5 bar

**Solenoid-Solenoid 5/3**

Coding: 1052.53.F.3.5.M2

Operational characteristics	
Fluid	Filtered air. No lubrication needed, if applied it shall be continuous
Max working pressure (bar)	10
Temperature °C	-5 ÷ +50
Flow rate at 6 bar with $\Delta p=1$ (NI/min)	1700

FUNCTION	
F	31 = Closed centres
	32 = Open centres
	33 = Pressured centres

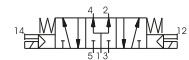
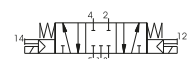
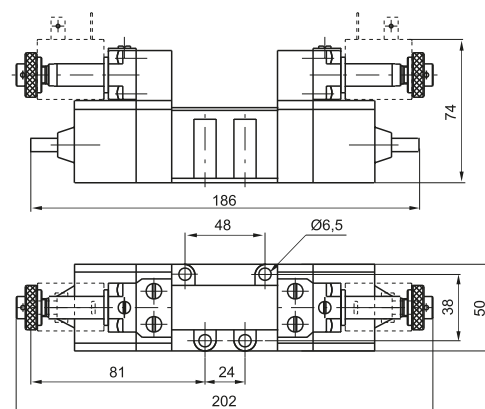

Weight 980 g  
Minimum piloting pressure 3 bar

► Base for 32 mm Solenoid valve

Coding: 1001.05

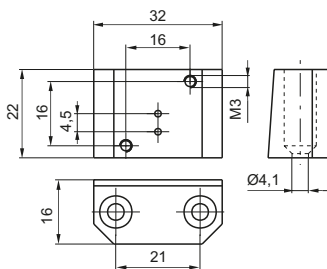

Weight 60 g

► Base CNOMO for 32 mm Solenoid valve

Coding: 1001.04

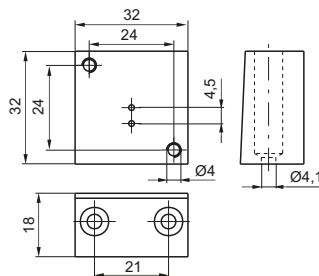
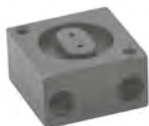

Weight 90 g

► Base with bottom connections size 1

Coding: 1001.00

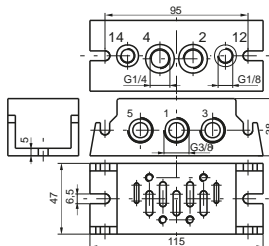

Weight 320 g  
1=INLET PORT 2-4=OUTLET PORTS  
3-5=EXHAUST PORTS 12-14=PILOT PORTS

► Base with side connections size 1

Coding: 1001.01

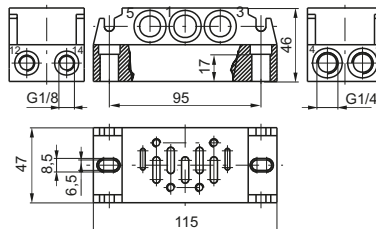

Weight 445 g  
1=INLET PORT 2-4=OUTLET PORTS  
3-5=EXHAUST PORTS 12-14=PILOT PORTS

► Inlet blocks

Coding: 1001.02

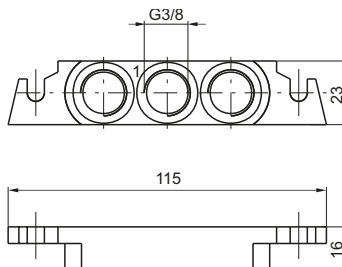

Weight 55 g

► Base with bottom connections size 2

Coding: 1002.00

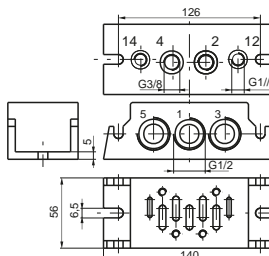

Weight 520 g  
1=INLET PORT 2-4=OUTLET PORTS  
3-5=EXHAUST PORTS 12-14=PILOT PORTS



**Pneumatic - Spring**

Coding: 1011.52.1.9

Operational characteristics	
Fluid	Filtered air. No lubrication needed, if applied it shall be continuous
Max working pressure (bar)	10
Temperature °C	-5 ÷ +50
Flow rate at 6 bar with Δp=1 (NI/min)	900

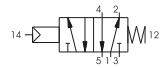
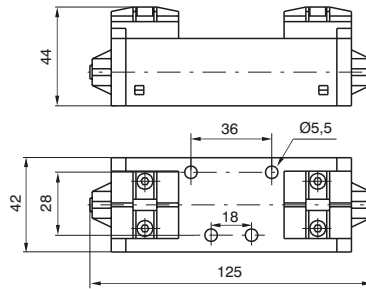

Weight 230 g  
Minimum piloting pressure 2,5 bar

**Pneumatic - Differential**

Coding: 1011.52.1.6

Operational characteristics	
Fluid	Filtered air. No lubrication needed, if applied it shall be continuous
Max working pressure (bar)	10
Temperature °C	-5 ÷ +50
Flow rate at 6 bar with Δp=1 (NI/min)	900

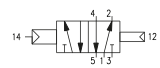
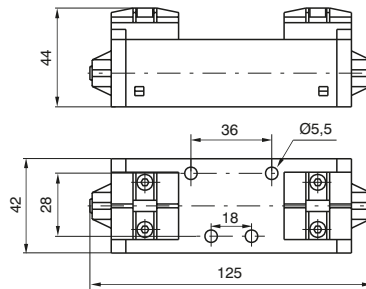

Weight 240 g  
Minimum piloting pressure 2 bar

**Pneumatic-Pneumatic 5/2**

Coding: 1011.52.1.8

Operational characteristics	
Fluid	Filtered air. No lubrication needed, if applied it shall be continuous
Max working pressure (bar)	10
Temperature °C	-5 ÷ +50
Flow rate at 6 bar with Δp=1 (NI/min)	900

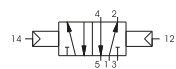
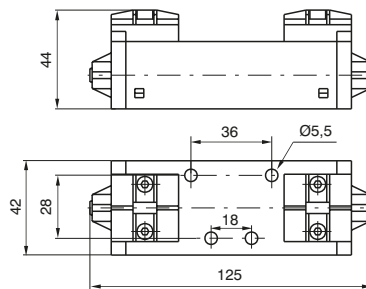

Weight 240 g  
Minimum piloting pressure 1,5 bar

**Pneumatic-Pneumatic 5/3**

Coding: 1011.53.1.8

Operational characteristics	
Fluid	Filtered air. No lubrication needed, if applied it shall be continuous
Max working pressure (bar)	10
Temperature °C	-5 ÷ +50
Flow rate at 6 bar with Δp=1 (NI/min)	900

FUNCTION
31 = Closed centres
32 = Open centres
33 = Pressured centres

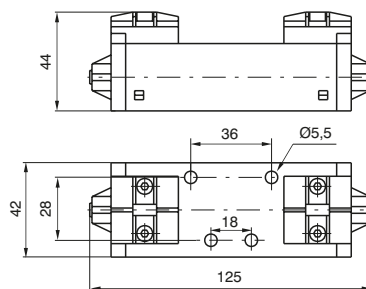
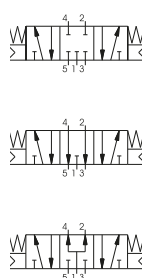

Weight 240 g  
Minimum piloting pressure 3 bar

**Solenoid - Spring**

Coding: 1011.52.3.9. **M**

Operational characteristics	
Fluid	Filtered air. No lubrication needed, if applied it shall be continuous
Max working pressure (bar)	10
Temperature °C	-5 ÷ +50
Flow rate at 6 bar with Δp=1 (NI/min)	900

<b>M</b>	MECHANICAL CODE SEE VALVES SERIES 300 CNOMO
----------	--

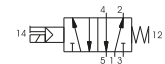
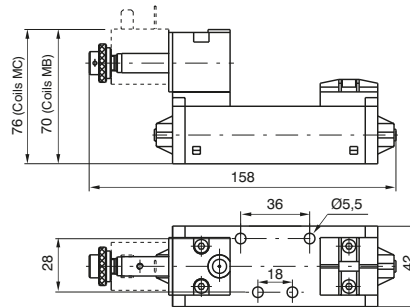

Weight 290 g  
Minimum piloting pressure 2,5 bar

**Solenoid-Differential**

Coding: 1011.52.3.6. **M**

Operational characteristics	
Fluid	Filtered air. No lubrication needed, if applied it shall be continuous
Max working pressure (bar)	10
Temperature °C	-5 ÷ +50
Flow rate at 6 bar with Δp=1 (NI/min)	900

<b>M</b>	MECHANICAL CODE SEE VALVES SERIES 300 CNOMO
----------	--

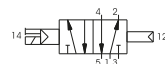
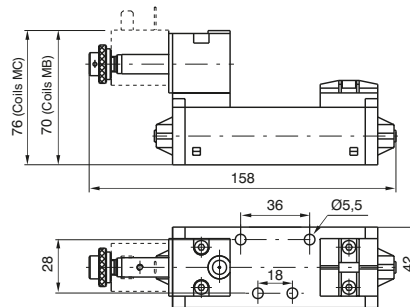

Weight 290 g  
Minimum piloting pressure 2 bar

**Solenoid-Solenoid 5/2**

Coding: 1011.52.3.5. **M**

Operational characteristics	
Fluid	Filtered air. No lubrication needed, if applied it shall be continuous
Max working pressure (bar)	10
Temperature °C	-5 ÷ +50
Flow rate at 6 bar with Δp=1 (NI/min)	900

<b>M</b>	MECHANICAL CODE SEE VALVES SERIES 300 CNOMO
----------	--

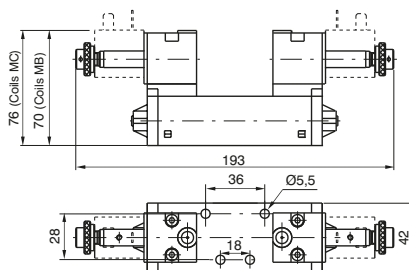

Weight 350 g  
Minimum piloting pressure 1,5 bar

**Solenoid-Solenoid 5/3**

Coding: 1011.53. **F**.3.5. **M**

Operational characteristics	
Fluid	Filtered air. No lubrication needed, if applied it shall be continuous
Max working pressure (bar)	10
Temperature °C	-5 ÷ +50
Flow rate at 6 bar with Δp=1 (NI/min)	900

<b>F</b>	FUNCTION 31 = Closed centres 32 = Open centres 33 = Pressured centres
<b>M</b>	MECHANICAL CODE SEE VALVES SERIES 300 CNOMO

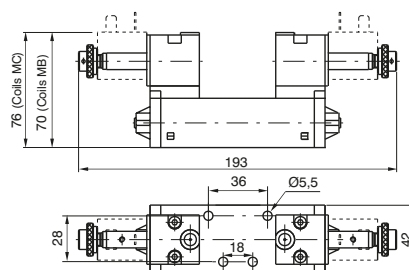
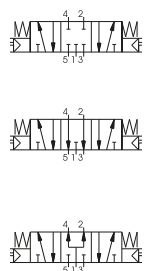

Weight 350 g  
Minimum piloting pressure 3 bar

**Pneumatic - Spring**

Coding: 1012.52.1.9

Operational characteristics	
Fluid	Filtered air. No lubrication needed, if applied it shall be continuous
Max working pressure (bar)	10
Temperature °C	-5 ÷ +50
Flow rate at 6 bar with Δp=1 (NI/min)	1600

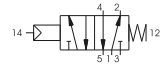
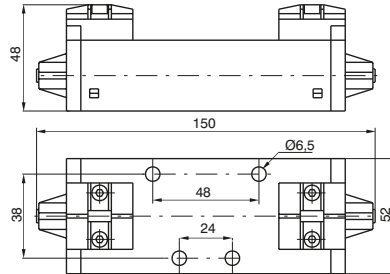

Weight 300 g  
Minimum piloting pressure 2,5 bar

**Pneumatic - Differential**

Coding: 1012.52.1.6

Operational characteristics	
Fluid	Filtered air. No lubrication needed, if applied it shall be continuous
Max working pressure (bar)	10
Temperature °C	-5 ÷ +50
Flow rate at 6 bar with Δp=1 (NI/min)	1600

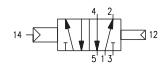
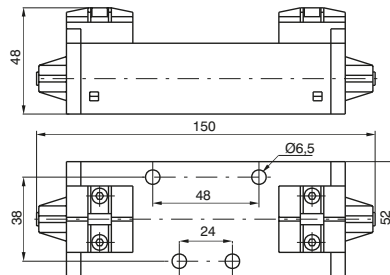

Weight 310 g  
Minimum piloting pressure 2 bar

**Pneumatic-Pneumatic 5/2**

Coding: 1012.52.1.8

Operational characteristics	
Fluid	Filtered air. No lubrication needed, if applied it shall be continuous
Max working pressure (bar)	10
Temperature °C	-5 ÷ +50
Flow rate at 6 bar with Δp=1 (NI/min)	1600

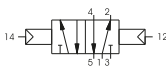
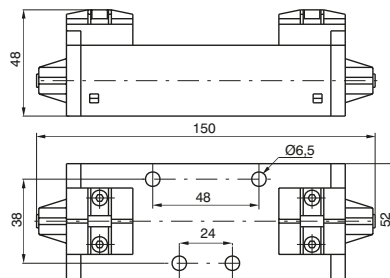

Weight 310 g  
Minimum piloting pressure 1,5 bar

**Pneumatic-Pneumatic 5/3**

Coding: 1012.53.1.8

Operational characteristics	
Fluid	Filtered air. No lubrication needed, if applied it shall be continuous
Max working pressure (bar)	10
Temperature °C	-5 ÷ +50
Flow rate at 6 bar with Δp=1 (NI/min)	1600

FUNCTION
<b>F</b> 31 = Closed centres
32 = Open centres
33 = Pressured centres

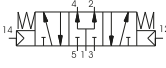
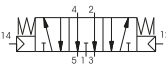
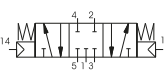
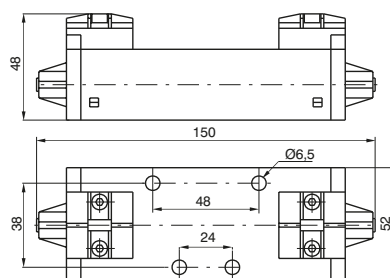

Weight 310 g  
Minimum piloting pressure 3 bar

1012.53.1.8

**Solenoid - Spring**

Coding: 1012.52.3.9.M

Operational characteristics	
Fluid	Filtered air. No lubrication needed, if applied it shall be continuous
Max working pressure (bar)	10
Temperature °C	-5 ÷ +50
Flow rate at 6 bar with Δp=1 (NI/min)	1600

M	MECHANICAL CODE SEE VALVES SERIES 300 CNOMO
---	--

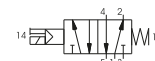
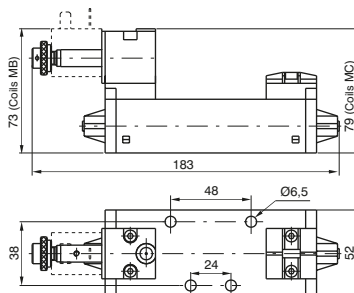

Weight 360 g  
Minimum piloting pressure 2,5 bar

**Solenoid-Differential**

Coding: 1012.52.3.6.M

Operational characteristics	
Fluid	Filtered air. No lubrication needed, if applied it shall be continuous
Max working pressure (bar)	10
Temperature °C	-5 ÷ +50
Flow rate at 6 bar with Δp=1 (NI/min)	1600

M	MECHANICAL CODE SEE VALVES SERIES 300 CNOMO
---	--

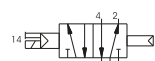
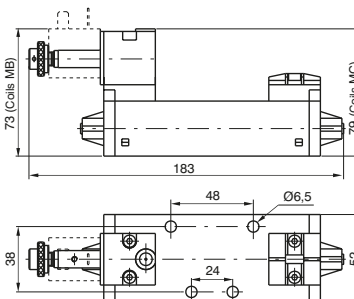

Weight 360 g  
Minimum piloting pressure 2 bar

**Solenoid-Differential**

Coding: 1012.52.3.5.M

Operational characteristics	
Fluid	Filtered air. No lubrication needed, if applied it shall be continuous
Max working pressure (bar)	10
Temperature °C	-5 ÷ +50
Flow rate at 6 bar with Δp=1 (NI/min)	1600

M	MECHANICAL CODE SEE VALVES SERIES 300 CNOMO
---	--

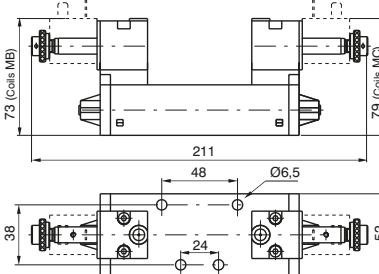

Weight 420 g  
Minimum piloting pressure 1,5 bar

**Solenoid-Solenoid 5/3**

Coding: 1012.53.F.3.5.M

Operational characteristics	
Fluid	Filtered air. No lubrication needed, if applied it shall be continuous
Max working pressure (bar)	10
Temperature °C	-5 ÷ +50
Flow rate at 6 bar with Δp=1 (NI/min)	1600

F	FUNCTION 31 = Closed centres 32 = Open centres 33 = Pressured centres
M	MECHANICAL CODE SEE VALVES SERIES 300 CNOMO

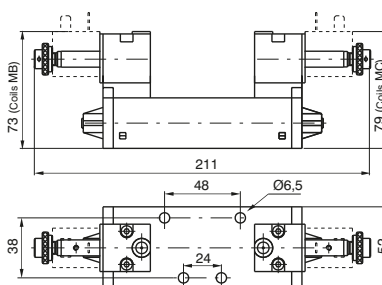
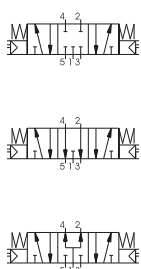

Weight 420 g  
Minimum piloting pressure 3 bar

1012.53.F.3.5.M

**Pneumatic - Spring**

Coding: 1013.52.1.9

Operational characteristics	
Fluid	Filtered air. No lubrication needed, if applied it shall be continuous
Max working pressure (bar)	10
Temperature °C	-5 ÷ +50
Flow rate at 6 bar with Δp=1 (NI/min)	3600

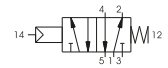
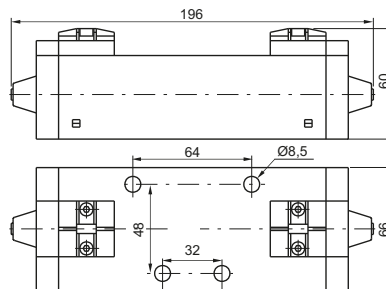

Weight 1000 g  
Minimum piloting pressure 2,5 bar

**Pneumatic - Differential**

Coding: 1013.52.1.6

Operational characteristics	
Fluid	Filtered air. No lubrication needed, if applied it shall be continuous
Max working pressure (bar)	10
Temperature °C	-5 ÷ +50
Flow rate at 6 bar with Δp=1 (NI/min)	3600

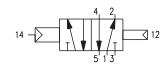
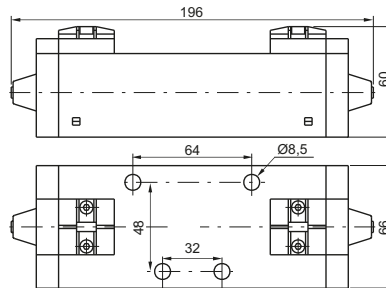

Weight 1020 g  
Minimum piloting pressure 2 bar

**Pneumatic-Pneumatic 5/2**

Coding: 1013.52.1.8

Operational characteristics	
Fluid	Filtered air. No lubrication needed, if applied it shall be continuous
Max working pressure (bar)	10
Temperature °C	-5 ÷ +50
Flow rate at 6 bar with Δp=1 (NI/min)	3600

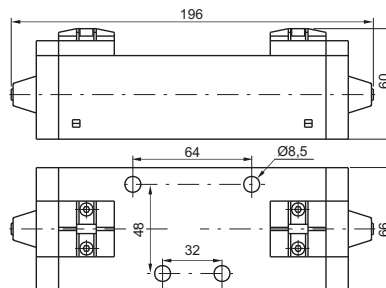

Weight 1050 g  
Minimum piloting pressure 1,5 bar

**Pneumatic-Pneumatic 5/3**

Coding: 1013.53.1.8

Operational characteristics	
Fluid	Filtered air. No lubrication needed, if applied it shall be continuous
Max working pressure (bar)	10
Temperature °C	-5 ÷ +50
Flow rate at 6 bar with Δp=1 (NI/min)	3000

FUNCTION
<b>F</b> 31 = Closed centres
32 = Open centres
33 = Pressured centres

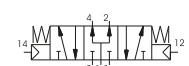
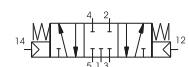
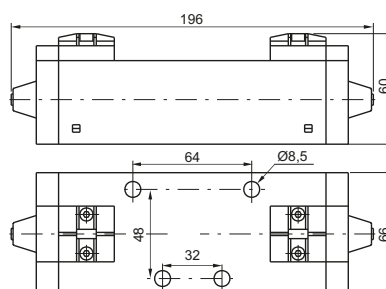

Weight 1050 g  
Minimum piloting pressure 3 bar

1013.53.1.8

**Solenoid - Spring**

Coding: 1013.52.3.9.M

Operational characteristics	
Fluid	Filtered air. No lubrication needed, if applied it shall be continuous
Max working pressure (bar)	10
Temperature °C	-5 ÷ +50
Flow rate at 6 bar with Δp=1 (NI/min)	3600

<b>M</b>	MECHANICAL CODE SEE VALVES SERIES 300 CNOMO
----------	--

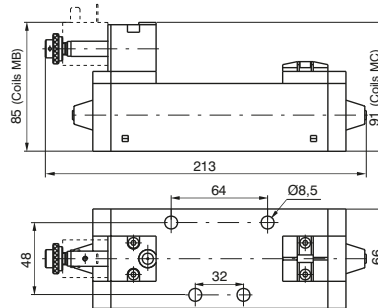

Weight 1060 g  
Minimum piloting pressure 2,5 bar

**Solenoid-Differential**

Coding: 1013.52.3.6.M

Operational characteristics	
Fluid	Filtered air. No lubrication needed, if applied it shall be continuous
Max working pressure (bar)	10
Temperature °C	-5 ÷ +50
Flow rate at 6 bar with Δp=1 (NI/min)	3600

<b>M</b>	MECHANICAL CODE SEE VALVES SERIES 300 CNOMO
----------	--

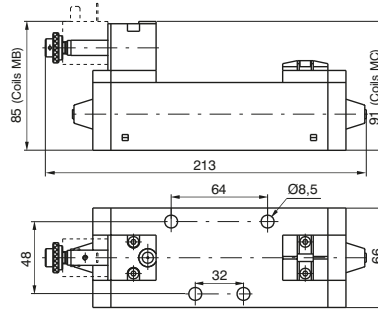

Weight 1080 g  
Minimum piloting pressure 2 bar

**Solenoid-Solenoid 5/2**

Coding: 1013.52.3.5.M

Operational characteristics	
Fluid	Filtered air. No lubrication needed, if applied it shall be continuous
Max working pressure (bar)	10
Temperature °C	-5 ÷ +50
Flow rate at 6 bar with Δp=1 (NI/min)	3600

<b>M</b>	MECHANICAL CODE SEE VALVES SERIES 300 CNOMO
----------	--

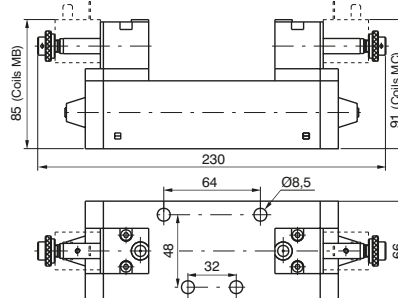

Weight 1170 g  
Minimum piloting pressure 1,5 bar

**Solenoid-Solenoid 5/3**

Coding: 1013.53.F.3.5.M

Operational characteristics	
Fluid	Filtered air. No lubrication needed, if applied it shall be continuous
Max working pressure (bar)	10
Temperature °C	-5 ÷ +50
Flow rate at 6 bar with Δp=1 (NI/min)	3000

<b>F</b>	FUNCTION 31 = Closed centres 32 = Open centres 33 = Pressured centres
<b>M</b>	MECHANICAL CODE SEE VALVES SERIES 300 CNOMO

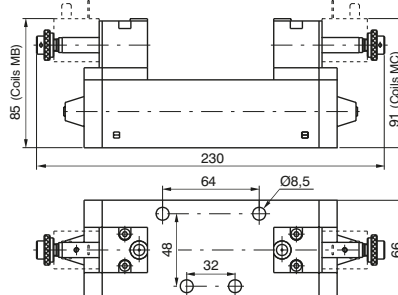
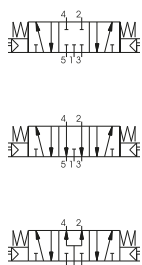

Weight 1170 g  
Minimum piloting pressure 3 bar

1013.53.F.3.5.M



## Series 1100 - Modular bases with side and bottom connections

### General

These bases are manufactured with the outlet and pilot ports on both the sides and the bottom faces giving the option for use with any application.

Unused ports must be blanked off using threaded plugs which are not included in the part number or price.

To isolate bases from each other for use with different supply pressures ports 1, 3 & 5 should be plugged underneath the seal.

The codes are:

**1101.17 (size 1) - 1102.17 (size 2) - 1103.17 (size 3)**

Modular bases

Coding: 110T.00

SIZE	
T 1	= Size 1
2	= Size 2
3	= Size 3

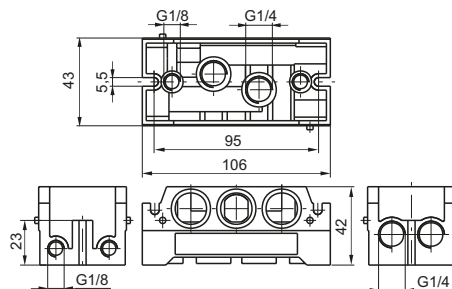

Weight 240 g

1101.00

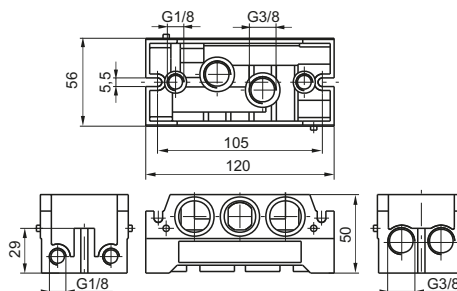

Weight 340 g

1102.00

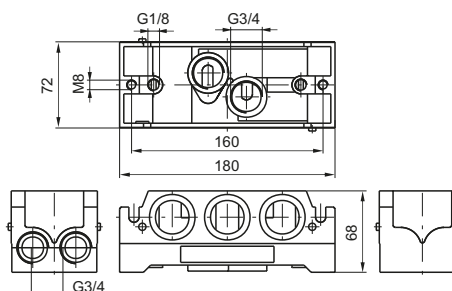

Weight 950 g

1103.00

Inlet blocks, Size 1

Coding: 1101.09

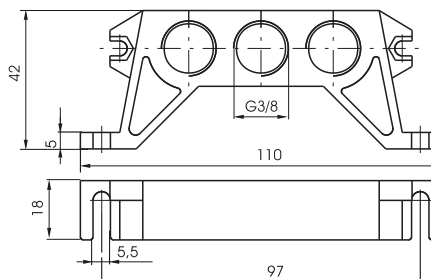

Weight 100 g

Inlet blocks, Size 3

Coding: 1103.11

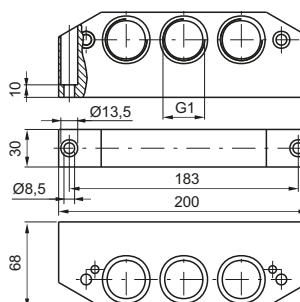

Weight 840 g

AIR DISTRIBUTION

1



**Inlet blocks**

Coding: 110**T**.**N**



Weight 160 g

1101.**N**

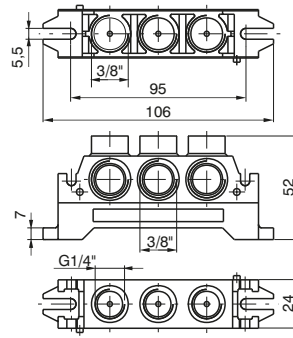

	SIZE
<b>T</b>	1 = Size 1 2 = Size 2
	WORKING PORTS SIZE
<b>N</b>	10 = Universal 11 = In line 12 = Top connections 13 = Bottom connections



Weight 230 g

1102.**N**

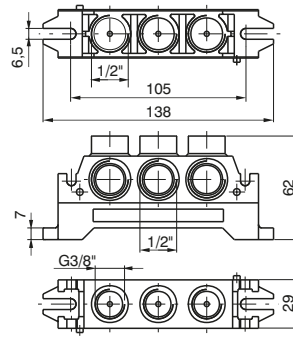

1  
AIR DISTRIBUTION

Single use bases

Coding: 110T.F

	SIZE
1	= Size 1
2	= Size 2
3	= Size 3
	SHAPE
14	= Shape A
15	= Shape B (only for sizes 1 & 2)

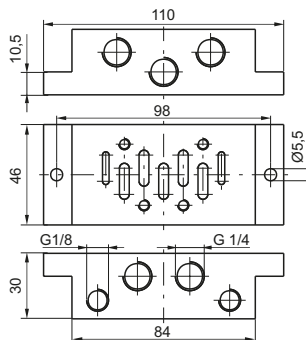

Weight 160 g

1101.14

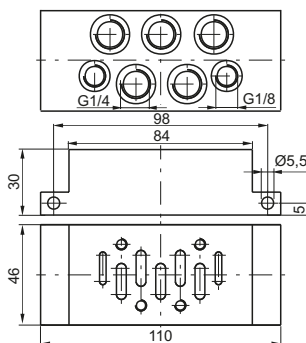

Weight 190 g

1101.15

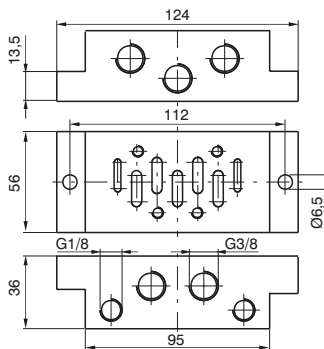

Weight 190 g

1102.14

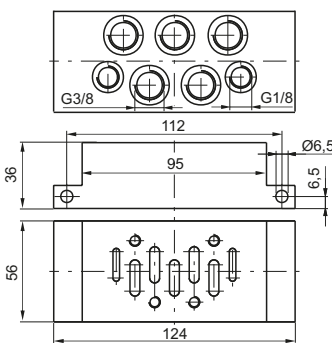
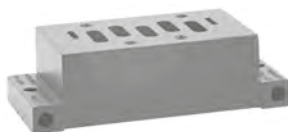

Weight 220 g

1102.15

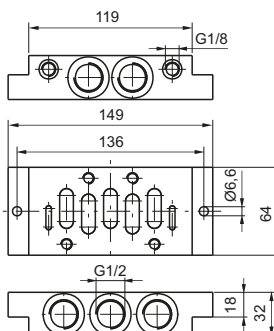
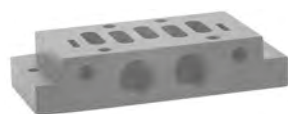

Weight 600 g

1103.14

AIR DISTRIBUTION

1

▶ Closing plate

Coding: 1100.1.16

	SIZE
1	= Size 1
2	= Size 2
3	= Size 3



1101.16

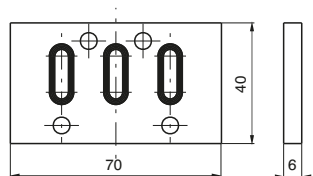

1102.16

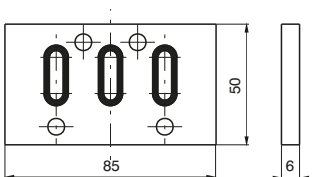

1103.16

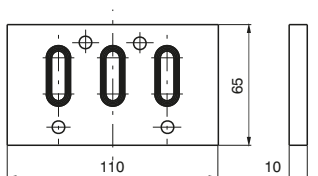

▶ Base adaptor

Coding: 1100.2.1

	SIZE
2	= Sizes 2-1
3	= Sizes 3-2



Weight 110 g

1100.2-1

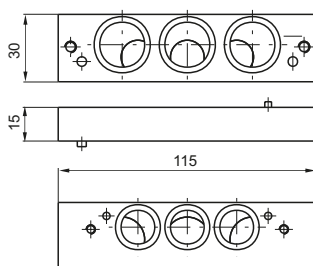

Weight 590 g

1100.3-2

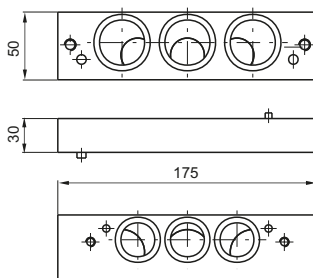



## Series 1000 M12 - Size 1, 2 & 3

### General

The ISO 5599/1 Solenoid valves Series 1000 M12 are available in three sizes with flow rates from 900 NI/min for size 1 up to the 3600 NI/min for size 3.

The standard features of the ISO valves are still included, however, they are now combined with a M12 electrical connector located in the middle of the valve to manage the electrical signals.

Versions are available to suit valves with both single and double 24VDC solenoids complete with IP65 protection.

All version are supplied with LED indicators

**“Shifting time of pneumatic directional control valves or moving parts, logic devices were measured in accordance to ISO 12238:2001, Pneumatic fluid power-Directional control valves-Measurement of shifting time”**

### Electrical characteristics

Electrical connector M12x1  
Protection degree IP65  
Input voltage 24VDC  
Nominal power 2,3W  
LED identification

### Monostable version

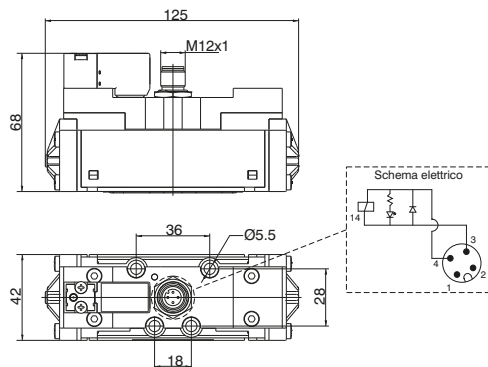

### Bistable version

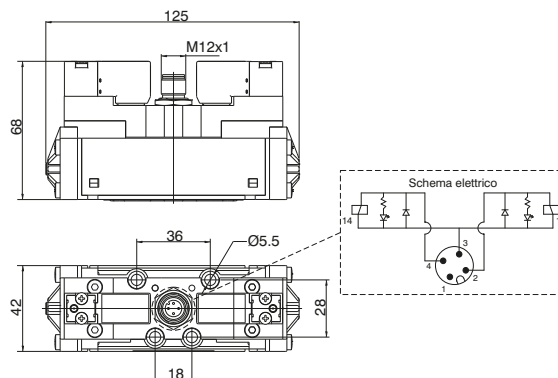

**Solenoid - Spring**

Coding: 1111.52.3.9.Ⓟ

Operational characteristics	
Fluid	Filtered air. No lubrication needed, if applied it shall be continuous
Max working pressure (bar)	10
Minimum piloting pressure (bar)	2.5
Temperature °C	-5 ÷ +50
Flow rate at 6 bar with Δp=1 (NI/min)	900
Response time according to ISO 12238, activation time (ms)	16
Response time according to ISO 12238, deactivation time (ms)	122

Ⓟ	COIL VOLTAGE
12P	= 24VDC

Shifting time of pneumatic directional control valves or moving parts, logic devices were measured in accordance to ISO 12238:2001



Weight 350 g

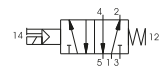
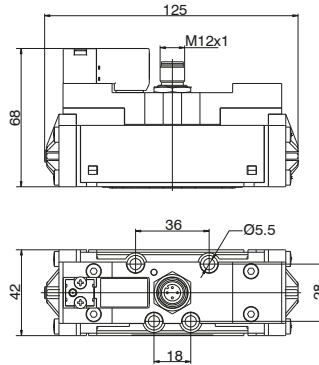

**Solenoid-Differential**

Coding: 1111.52.3.6.Ⓟ

Operational characteristics	
Fluid	Filtered air. No lubrication needed, if applied it shall be continuous
Max working pressure (bar)	10
Minimum piloting pressure (bar)	2
Temperature °C	-5 ÷ +50
Flow rate at 6 bar with Δp=1 (NI/min)	900
Response time according to ISO 12238, activation time (ms)	32
Response time according to ISO 12238, deactivation time (ms)	51

Ⓟ	COIL VOLTAGE
12P	= 24VDC

Shifting time of pneumatic directional control valves or moving parts, logic devices were measured in accordance to ISO 12238:2001



Weight 356 g

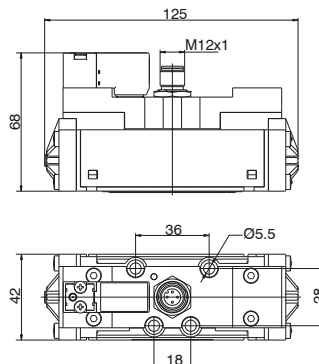

**Solenoid-Solenoid 5/2**

Coding: 1111.52.3.5.Ⓟ

Operational characteristics	
Fluid	Filtered air. No lubrication needed, if applied it shall be continuous
Max working pressure (bar)	10
Minimum piloting pressure (bar)	1.5
Temperature °C	-5 ÷ +50
Flow rate at 6 bar with Δp=1 (NI/min)	900
Response time according to ISO 12238, activation time (ms)	13
Response time according to ISO 12238, deactivation time (ms)	14

Ⓟ	COIL VOLTAGE
12P	= 24VDC

Shifting time of pneumatic directional control valves or moving parts, logic devices were measured in accordance to ISO 12238:2001



Weight 390 g

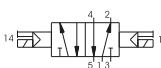
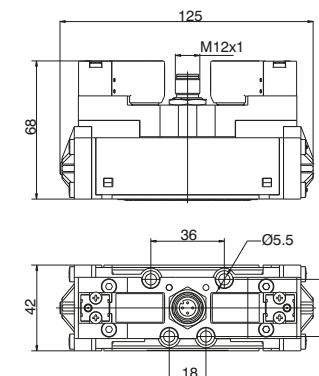



Solenoid-Solenoid 5/3

Coding: 1111.53.F.3.5.T

Operational characteristics	
Fluid	Filtered air. No lubrication needed, if applied it shall be continuous
Max working pressure (bar)	10
Minimum piloting pressure (bar)	3
Temperature °C	-5 ÷ +50
Flow rate at 6 bar with Δp=1 (NI/min)	900
Response time according to ISO 12238, activation time (ms)	18 (Closed centres) 18 (Open centres) 19 (Pressured centres)
Response time according to ISO 12238, deactivation time (ms)	19 (Closed centres) 20 (Open centres) 18 (Pressured centres)

FUNCTION	
F	31 = Closed centres
	32 = Open centres
	33 = Pressured centres
COIL VOLTAGE	
T	12P = 24VDC

Shifting time of pneumatic directional control valves or moving parts, logic devices were measured in accordance to ISO 12238:2001

1 AIR DISTRIBUTION

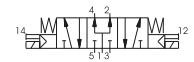
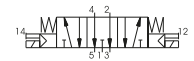
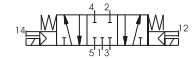
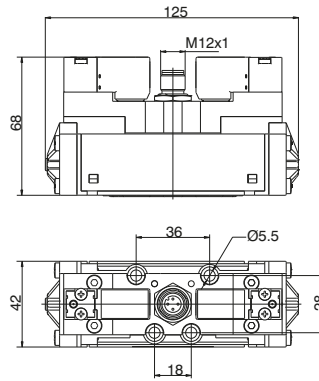

Weight 392 g

**Solenoid - Spring**

Coding: 1112.52.3.9.1

Operational characteristics	
Fluid	Filtered air. No lubrication needed, if applied it shall be continuous
Max working pressure (bar)	10
Minimum piloting pressure (bar)	2.5
Temperature °C	-5 ÷ +50
Flow rate at 6 bar with Δp=1 (NI/min)	1600
Response time according to ISO 12238, activation time (ms)	24
Response time according to ISO 12238, deactivation time (ms)	124

<b>1</b> COIL VOLTAGE
12P = 24VDC

Shifting time of pneumatic directional control valves or moving parts, logic devices were measured in accordance to ISO 12238:2001



Weight 510 g

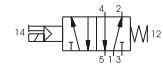
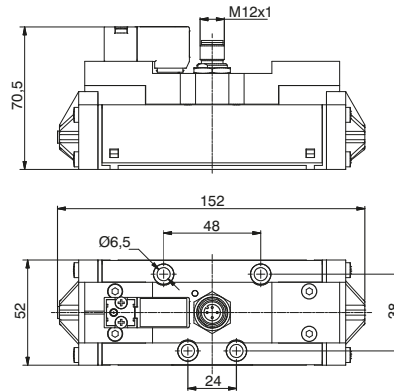

**Solenoid-Differential**

Coding: 1112.52.3.6.1

Operational characteristics	
Fluid	Filtered air. No lubrication needed, if applied it shall be continuous
Max working pressure (bar)	10
Minimum piloting pressure (bar)	2
Temperature °C	-5 ÷ +50
Flow rate at 6 bar with Δp=1 (NI/min)	1600
Response time according to ISO 12238, activation time (ms)	37
Response time according to ISO 12238, deactivation time (ms)	90

<b>1</b> COIL VOLTAGE
12P = 24VDC

Shifting time of pneumatic directional control valves or moving parts, logic devices were measured in accordance to ISO 12238:2001



Weight 515 g

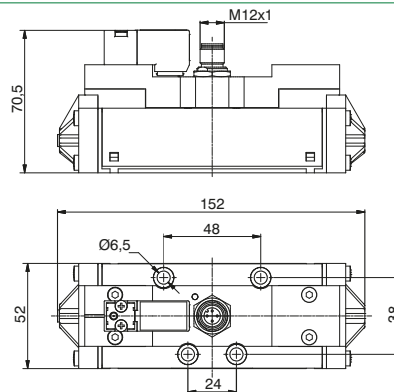

**Solenoid-Solenoid 5/2**

Coding: 1112.52.3.5.1

Operational characteristics	
Fluid	Filtered air. No lubrication needed, if applied it shall be continuous
Max working pressure (bar)	10
Minimum piloting pressure (bar)	1.5
Temperature °C	-5 ÷ +50
Flow rate at 6 bar with Δp=1 (NI/min)	1600
Response time according to ISO 12238, activation time (ms)	17
Response time according to ISO 12238, deactivation time (ms)	20

<b>1</b> COIL VOLTAGE
12P = 24VDC

Shifting time of pneumatic directional control valves or moving parts, logic devices were measured in accordance to ISO 12238:2001



Weight 550 g

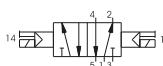
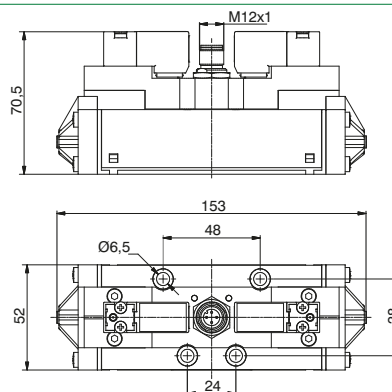



Solenoid-Solenoid 5/3

Coding: 1112.53.F.3.5.T

Operational characteristics	
Fluid	Filtered air. No lubrication needed, if applied it shall be continuous
Max working pressure (bar)	10
Minimum piloting pressure (bar)	3
Temperature °C	-5 ÷ +50
Flow rate at 6 bar with Δp=1 (NI/min)	1600
Response time according to ISO 12238, activation time (ms)	18 (Closed centres) 18 (Open centres) 20 (Pressured centres)
Response time according to ISO 12238, deactivation time (ms)	112 (Closed centres) 106 (Open centres) 118 (Pressured centres)

FUNCTION	
F	31 = Closed centres
	32 = Open centres
	33 = Pressured centres
COIL VOLTAGE	
T	12P = 24VDC

Shifting time of pneumatic directional control valves or moving parts, logic devices were measured in accordance to ISO 12238:2001

1

AIR DISTRIBUTION

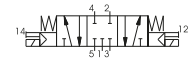
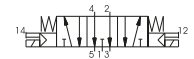
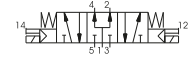
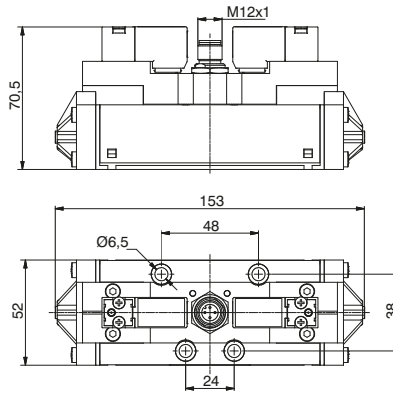
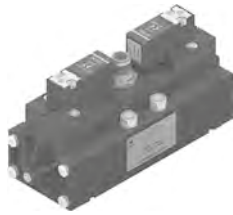

Weight 560 g



**Solenoid - Spring**

Coding: 1113.52.3.9.①

Operational characteristics	
Fluid	Filtered air. No lubrication needed, if applied it shall be continuous
Max working pressure (bar)	10
Minimum piloting pressure (bar)	2.5
Temperature °C	-5 ÷ +50
Flow rate at 6 bar with Δp=1 (NI/min)	3600
Response time according to ISO 12238, activation time (ms)	46
Response time according to ISO 12238, deactivation time (ms)	254

① COIL VOLTAGE	
12P =	24VDC

*Shifting time of pneumatic directional control valves or moving parts, logic devices were measured in accordance to ISO 12238:2001*

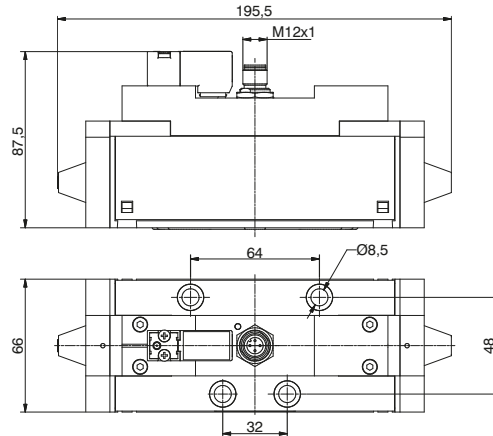
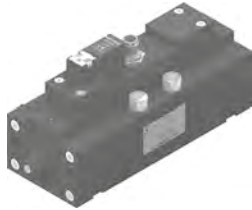

Weight 1360 g

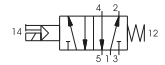

**Solenoid-Differential**

Coding: 1113.52.3.6.①

Operational characteristics	
Fluid	Filtered air. No lubrication needed, if applied it shall be continuous
Max working pressure (bar)	10
Minimum piloting pressure (bar)	2
Temperature °C	-5 ÷ +50
Flow rate at 6 bar with Δp=1 (NI/min)	3600
Response time according to ISO 12238, activation time (ms)	78
Response time according to ISO 12238, deactivation time (ms)	180

① COIL VOLTAGE	
12P =	24VDC

*Shifting time of pneumatic directional control valves or moving parts, logic devices were measured in accordance to ISO 12238:2001*

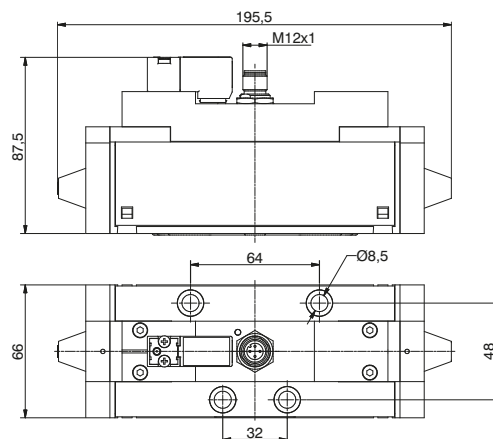

Weight 1360 g

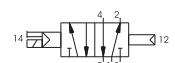

**Solenoid-Solenoid 5/2**

Coding: 1113.52.3.5.1

Operational characteristics	
Fluid	Filtered air. No lubrication needed, if applied it shall be continuous
Max working pressure (bar)	10
Minimum piloting pressure (bar)	1.5
Temperature °C	-5 ÷ +50
Flow rate at 6 bar with Δp=1 (NI/min)	3600
Response time according to ISO 12238, activation time (ms)	32
Response time according to ISO 12238, deactivation time (ms)	37

<b>COIL VOLTAGE</b>
<b>12P = 24VDC</b>

Shifting time of pneumatic directional control valves or moving parts, logic devices were measured in accordance to ISO 12238:2001

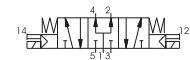
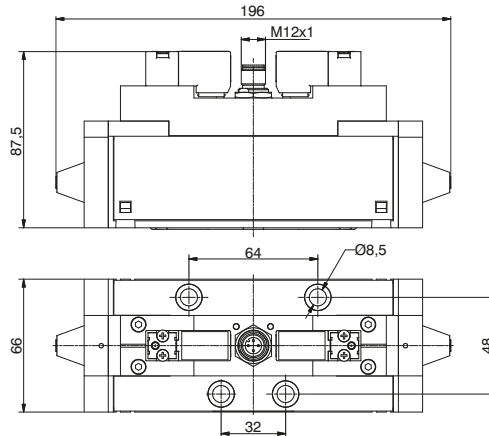

Weight 1370 g

**Solenoid-Solenoid 5/3**

Coding: 1113.53.F.3.5.1

Operational characteristics	
Fluid	Filtered air. No lubrication needed, if applied it shall be continuous
Max working pressure (bar)	10
Minimum piloting pressure (bar)	3
Temperature °C	-5 ÷ +50
Flow rate at 6 bar with Δp=1 (NI/min)	3600
Response time according to ISO 12238, activation time (ms)	30 (Closed centres) 30 (Open centres) 32 (Pressured centres)
Response time according to ISO 12238, deactivation time (ms)	305 (Closed centres) 230 (Open centres) 270 (Pressured centres)

<b>COIL VOLTAGE</b>
<b>12P = 24VDC</b>

Shifting time of pneumatic directional control valves or moving parts, logic devices were measured in accordance to ISO 12238:2001

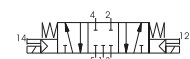
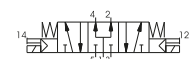
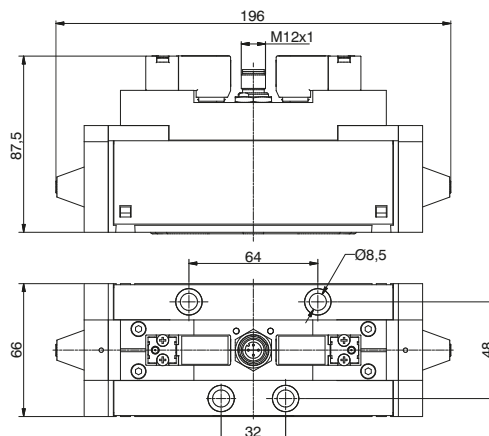
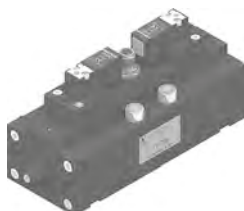

Weight 1380 g



## Series 600 - M5 - G1"

### General

These accessories are a range of devices for completing a pneumatic circuit. These valves, with their special functions, are inserted between two valves, between a valve and a cylinder, or following a cylinder.

One of the particular characteristic of these accessories is that they are automatically actuated without the need for external commands. Usually, operation and idle are controlled by the presence or absence of pressure as, for example, in the case of quick exhaust valves which pilots itself as a selector, changing the flow direction as the signal goes off and on.

On the other hand, other components are inert. That is, they do not have any internal variable function which is sensitive to pressure. Among these components are silencers, manifolds and flow regulators.

There are also the flow regulators, which like electronic components, can be defined as variable resistences. They are fundamental in regulating the flow rate, provide precise timings and regulate the cylinders' speed.

The selector valves, with "AND" and "OR" functions, are logic functions components which often are an essential element. Furthermore, they are built to allow high flow rate which cannot be obtained by classic pneumatic logic.

The block valves lock the cylinder in a position, avoiding unexpected depressurization of the cylinder's chamber due to lack of compressed air at the inlet port. Practically, it is a piloted unidirectional valve that blocks the exhaust port when there is no air in the pilot circuit.

Finally the economizer valves are in fact a pressure reducer valves installed between valve and cylinder for reducing the air consumption. For example this is applicable on the cylinder return stroke without penalizing the exhaust as happens with FRL pressure regulator.

### Construction characteristics

We have not listed all different materials used for the construction of these components because the list would be too the long. We use corrosion proof material, brass or anodized aluminium and the most appropriate specific mixture for seals. If more information is required please contact our technical department.

### Use and maintenance

In operation pay attention to the minimum and maximum criteria for temperature and pressure, and ensure good quality compressed air. In a dirty environment, protect the exhaust ports.

In this case, maintenance is minimal and is necessary only if the air is particularly dirty.

The components most subject to damage by the accumulation of dirt are flow regulators with fine regulation and silencers. As for regulators, follow the normal procedure for disassembling, washing with non-chemical cleaning agents and remounting. The silencers need only to be rinsed in petrol or solvent and blown dry with compressed air.

The number of requests for spare seals for flow regulators and shuttle valves are statistically irrelevant. More often, it is necessary to replace the lining of the quick exhaust because of the wear it undergoes due to the particular conditions of operating.

**ATTENTION:** use hydraulic oil class H for lubrication such as MAGNA GC 32 (Castrol).

**Miniature flow control valve M5 - Ø3 tube**

Coding: 6.01.305. **F**

Operational characteristics	
Fluid	Filtered air. No lubrication needed, if applied it shall be continuous
Max working pressure (bar)	10
Temperature °C	-5 ÷ +70
Orifice size (mm)	1.5

FUNCTION	
<b>F</b> 1.2	= Unidirectional
2.1	= Unidirectional
1.1	= Bidirectional

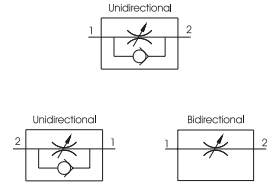
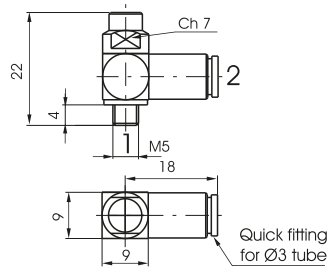

Weight 14 g

**Miniature flow control valve M5 - Ø3 tube, with adjustment knob**

Coding: 6.01.305. **F**P

Operational characteristics	
Fluid	Filtered air. No lubrication needed, if applied it shall be continuous
Max working pressure (bar)	10
Temperature °C	-5 ÷ +70
Orifice size (mm)	1.5

FUNCTION	
<b>F</b> 1.2	= Unidirectional
2.1	= Unidirectional
1.1	= Bidirectional

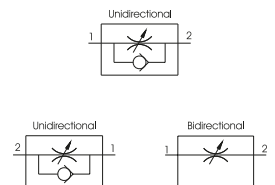
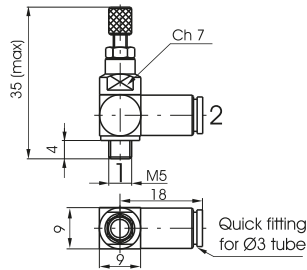

Weight 16 g

**Miniature flow control valve M5 - Ø3,17 tube**

Coding: 6.01.315. **F**

Operational characteristics	
Fluid	Filtered air. No lubrication needed, if applied it shall be continuous
Max working pressure (bar)	10
Temperature °C	-5 ÷ +70
Orifice size (mm)	1.5

FUNCTION	
<b>F</b> 1.2	= Unidirectional
2.1	= Unidirectional
1.1	= Bidirectional

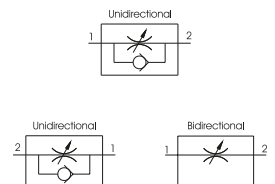
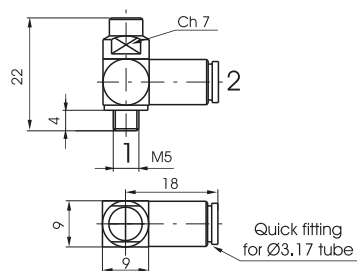

Weight 14 g

**Miniature flow control valve M5 - Ø3,17 tube, with adjustment knob**

Coding: 6.01.315. **F**P

Operational characteristics	
Fluid	Filtered air. No lubrication needed, if applied it shall be continuous
Max working pressure (bar)	10
Temperature °C	-5 ÷ +70
Orifice size (mm)	1.5

FUNCTION	
<b>F</b> 1.2	= Unidirectional
2.1	= Unidirectional
1.1	= Bidirectional

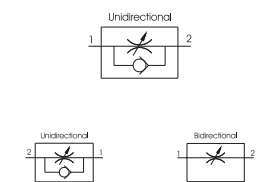
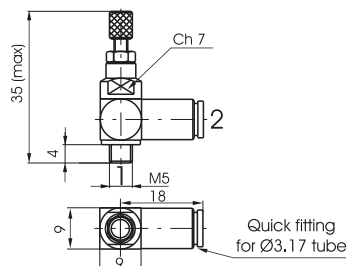

Weight 16 g

► Miniature flow control valve M5 - Ø4 tube

Coding: 6.01.45.ⓕ

Operational characteristics	
Fluid	Filtered air. No lubrication needed, if applied it shall be continuous
Max working pressure (bar)	10
Temperature °C	-5 ÷ +70
Orifice size (mm)	1.5

FUNCTION	
ⓕ 1.2 =	Unidirectional
2.1 =	Unidirectional
1.1 =	Bidirectional

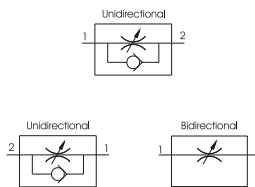
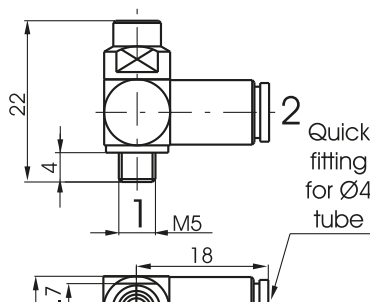

Weight 14 g

► Miniature flow control valve M5 - Ø4 tube, with adjustment knob

Coding: 6.01.45.ⓕP

Operational characteristics	
Fluid	Filtered air. No lubrication needed, if applied it shall be continuous
Max working pressure (bar)	10
Temperature °C	-5 ÷ +70
Orifice size (mm)	1.5

FUNCTION	
ⓕ 1.2 =	Unidirectional
2.1 =	Unidirectional
1.1 =	Bidirectional

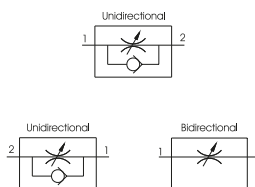
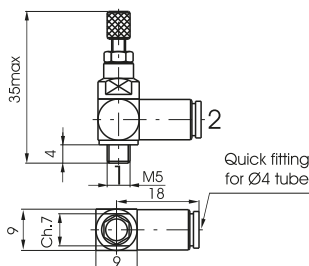

Weight 16 g

► Flow control valve M5 - in line ports

Coding: 6.01.ⓕ

Operational characteristics	
Fluid	Filtered air. No lubrication needed, if applied it shall be continuous
Max working pressure (bar)	10
Temperature °C	-5 ÷ +70
Orifice size (mm)	2

FUNCTION	
ⓕ 05 =	Unidirectional
05/2 =	Bidirectional

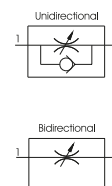
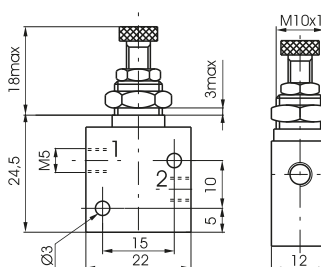

Weight 48 g

► Flow control valve M5 - port at 90°

Coding: 6.01.05.ⓕ

Operational characteristics	
Fluid	Filtered air. No lubrication needed, if applied it shall be continuous
Max working pressure (bar)	10
Temperature °C	-5 ÷ +70
Orifice size (mm)	2

FUNCTION	
ⓕ 90 =	Unidirectional
90/2 =	Bidirectional

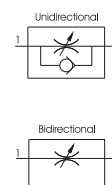
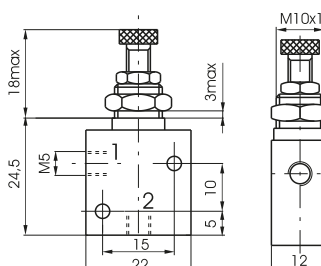

Weight 48 g

▶ Flow control valve M5 - with a through bolt

Coding: 6.01.05. **F**

Operational characteristics	
Fluid	Filtered air. No lubrication needed, if applied it shall be continuous
Max working pressure (bar)	10
Temperature °C	-5 ÷ +70
Orifice size (mm)	2

FUNCTION	
<b>F</b> 180 =	Unidirectional
180/2 =	Bidirectional

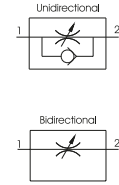
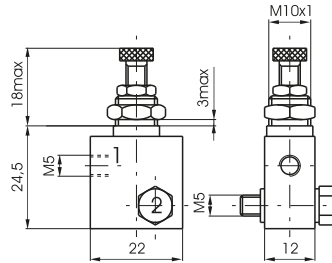

Weight 52 g

▶ Flow control valve G1/8" - ultrasensitive

Coding: 6.01.18/ **F**

Operational characteristics	
Fluid	Filtered air. No lubrication needed, if applied it shall be continuous
Max working pressure (bar)	10
Temperature °C	-5 ÷ +70
Orifice size (mm)	3

FUNCTION	
<b>F</b> 4 =	Unidirectional
5 =	Bidirectional

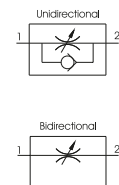
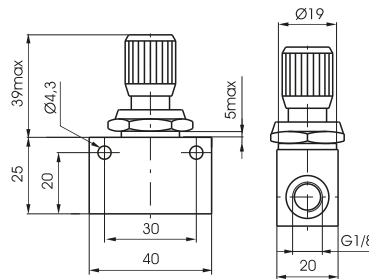

Weight 100 g

▶ Flow control valve G1/8" - ultrasensitive with lock nut

Coding: 6.01.18/ **F**

Operational characteristics	
Fluid	Filtered air. No lubrication needed, if applied it shall be continuous
Max working pressure (bar)	10
Temperature °C	-5 ÷ +70
Orifice size (mm)	3

FUNCTION	
<b>F</b> 6 =	Unidirectional
7 =	Bidirectional

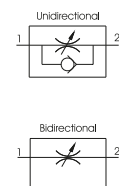
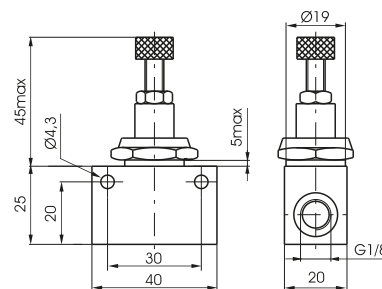

Weight 105 g

▶ Flow control valve G1/8"

Coding: 6.01. **F**

Operational characteristics	
Fluid	Filtered air. No lubrication needed, if applied it shall be continuous
Max working pressure (bar)	10
Temperature °C	-5 ÷ +70
Orifice size (mm)	4

FUNCTION	
<b>F</b> 18N =	Unidirectional
18NE =	Bidirectional
18/1N =	Unidirectional economic version
18/1NE =	Bidirectional economic version

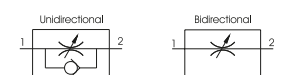
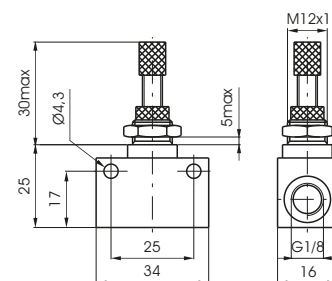

Weight 50 g

**Flow control valve G1/4" - compact type - unidirectional**

Coding: 6.01.14/1

Operational characteristics	
Fluid	Filtered air. No lubrication needed, if applied it shall be continuous
Max working pressure (bar)	10
Temperature °C	-5 ÷ +70
Orifice size (mm)	5.5

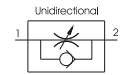
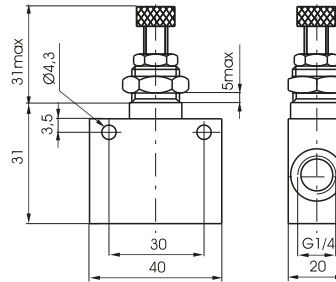

Weight 100 g

**Flow control valve G1/4"**

Coding: 6.01.F

Operational characteristics	
Fluid	Filtered air. No lubrication needed, if applied it shall be continuous
Max working pressure (bar)	10
Temperature °C	-5 ÷ +70
Orifice size (mm)	7

FUNCTION	
F 14N	= Unidirectional
F 14/1N	= Bidirectional

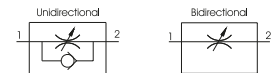
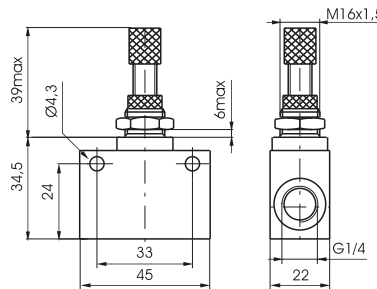

Weight 105 g

**Flow control valve G1/2"**

Coding: 6.01.F

Operational characteristics	
Fluid	Filtered air. No lubrication needed, if applied it shall be continuous
Max working pressure (bar)	10
Temperature °C	-5 ÷ +70
Orifice size (mm)	12

FUNCTION	
F 12N	= Unidirectional
F 12/1N	= Bidirectional

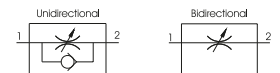
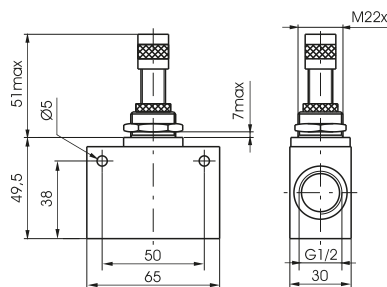

Weight 290 g

**Flow control valve G3/4" - unidirectional**

Coding: 6.01.34

Operational characteristics	
Fluid	Filtered air. No lubrication needed, if applied it shall be continuous
Max working pressure (bar)	10
Temperature °C	-5 ÷ +70
Orifice size (mm)	12

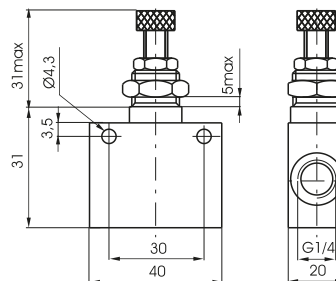

Weight 500 g

1  
AIR DISTRIBUTION

AIR DISTRIBUTION

**Quick exhaust valve**

Coding: 6.02.1

Operational characteristics	
Fluid	Filtered air. No lubrication needed, if applied it shall be continuous
Max working pressure (bar)	0.5÷10
Temperature °C	-5 ÷ +70

CONNECTION (IN)	
05	= M5
18	= G1/8"
14	= G1/4"
12	= G1/2"

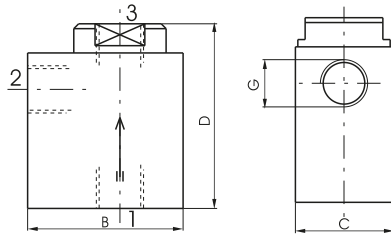

	G	M5	1/8"	1/4"	1/2"
B	22	32	35	52	
C	12	20	25	37	
D	28	38	50	62	
Weight g	50	62	112	310	
Flow rate NI/min at 6 bar with $\Delta p = 1$	from 1 to 2	120	480	960	3300
Flow rate NI/min at 6 bar on free exhaust	from 2 to 3	220	1100	1930	6500

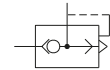

Weight \*see table"

**Quick exhaust in line valve**

Coding: 6.02.1.C.L

Operational characteristics	
Fluid	Filtered air. No lubrication needed, if applied it shall be continuous
Max working pressure (bar)	10
Temperature °C	-5 ÷ +70

CONNECTION (IN)	
M5	= M5
03	= tube Ø3
04	= tube Ø4
06	= tube Ø6
WORKING PORTS SIZE	
M5	= M5
M7	= M7
18	= G1/8"
04	= tube Ø4
06	= tube Ø6

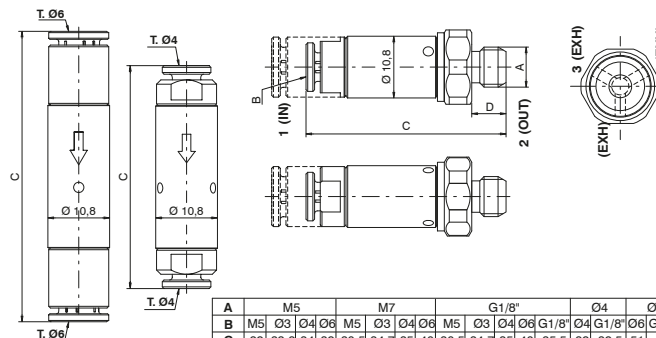

	M5		M7		G1/8"		04	06
B	M5	Ø3	Ø4	Ø6	M5	Ø3	Ø4	Ø6
C	29	33,2	34	39	30,5	34,7	35	40
D	4,5				6		-	5,5
Weight (g)	17		18		17		20	18
Flow rate NI/min at 6 bar with $\Delta p=1$ (from 1 to 2)	90		110		90		110	
Flow rate NI/min at 6 bar on free exhaust (from 2 to 3)	240		350		240		350	

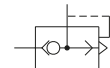

Weight \*see table"

**Exhaust flow control**

Coding: 6.03.1

Operational characteristics	
Fluid	Filtered air. No lubrication needed, if applied it shall be continuous
Max working pressure (bar)	10
Temperature °C	-5 ÷ +70

CONNECTION (IN)	
05	= M5
18	= G1/8"
14	= G1/4"
12	= G1/2"

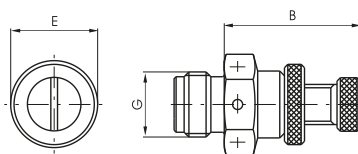

G	M5	1/8"	1/4"	1/2"
B	21	18	22	39
E	9	13	16	25
Weight g	10	18	32	155



Weight \*see table"



Shuttle valve "OR"

Coding: 6.04.1

Operational characteristics	
Fluid	Filtered air. No lubrication needed, if applied it shall be continuous
Max working pressure (bar)	10
Temperature °C	-5 ÷ +70

CONNECTION (IN)	
1	05 = M5
	18 = G1/8"
	14 = G1/4"

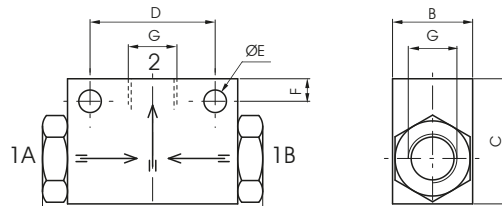

G	M5	1/8"	1/4"
A	27	44	62
B	12	16	22
C	17	25	30
D	15	25	35
E	3,5	4,5	5,5
F	3,5	4,5	5,5
Weight g	33	50	110

Flow rate at 6 bar with  $\Delta p = 1$

Nl/min.	110	700	2200
---------	-----	-----	------

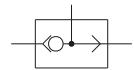

Weight "see table"

Shuttle valve "OR" - T=4

Coding: 6.04.04

Operational characteristics	
Fluid	Filtered air. No lubrication needed, if applied it shall be continuous
Max working pressure (bar)	10
Temperature °C	-5 ÷ +70
Flow rate at 6 bar with $\Delta p = 1$ (Nl/min)	105
Orifice size (mm)	2.5
Working ports size	Fitting T=4

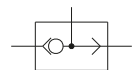
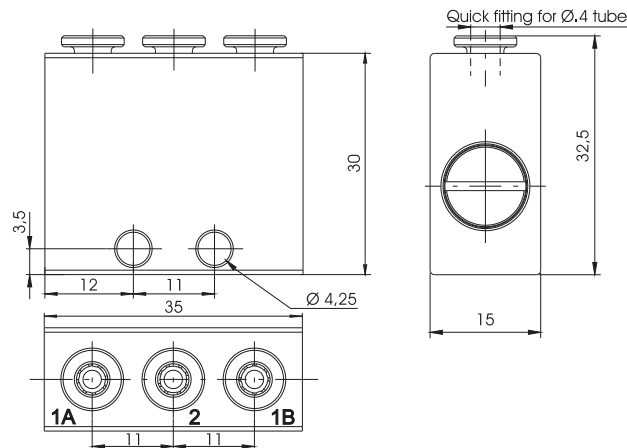

Weight 50g

Shuttle valve "AND" - M5 - G1/8"

Coding: 6.04.1/1

Operational characteristics	
Fluid	Filtered air. No lubrication needed, if applied it shall be continuous
Max working pressure (bar)	10
Temperature °C	-5 ÷ +70

CONNECTION (IN)	
1	05 = M5
	18 = G1/8"

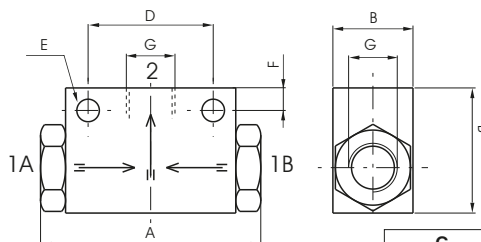

G	M5	1/8"
A	36	44
B	12	16
C	22	45
D	20	25
E	3,2	4,5
F	3,5	4,5
Weight g	30	50

Flow rate at 6 bar with  $\Delta p = 1$

Nl/min.	100	480
---------	-----	-----

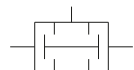

Weight "see table"



AIR DISTRIBUTION

**Shuttle valve "AND" - T=4**

Coding: 6.04.04/1

Operational characteristics	
Fluid	Filtered air. No lubrication needed, if applied it shall be continuous
Max working pressure (bar)	10
Temperature °C	-5 ÷ +70
Flow rate at 6 bar with Δp=1 (Nl/min)	105
Orifice size (mm)	2.5
Working ports size	Fitting T=4

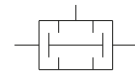
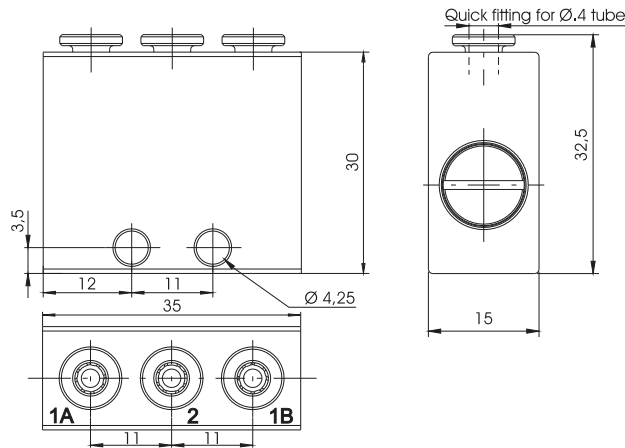

Weight 50 g

**Silencers steel wool**

Coding: 6.05.1

Operational characteristics	
Fluid	Filtered air. No lubrication needed, if applied it shall be continuous
Max working pressure (bar)	10
Temperature °C	-5 ÷ +70

CONNECTION (IN)	
18	= G1/8"
14	= G1/4"
38	= G3/8"
12	= G1/2"

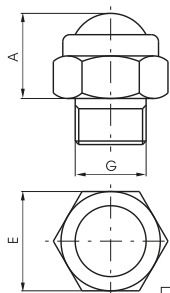

G	1/8"	1/4"	3/8"	1/2"
A	12	13	15	17
E	14	17	22	27
Weight g	8	16	32	44



Weight \*see table"

**Silencers brass**

Coding: 6.06.1

Operational characteristics	
Fluid	Filtered air. No lubrication needed, if applied it shall be continuous
Max working pressure (bar)	10
Temperature °C	-5 ÷ +70

CONNECTION (IN)	
05	= M5
18	= G1/8"
14	= G1/4"
38	= G3/8"
12	= G1/2"
34	= G3/4"
01	= G1"

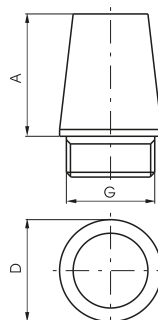

G	M5	1/8"	1/4"	3/8"	1/2"	3/4"	1"
A	17	15	18	28	32	40	50
D	8	12	15	19	23	29	38
Weight g	4	8	15	35	50	92	182



Weight \*see table"



**G 1/8" compact check valves**

Coding: 6.07.18.Ⓒ

Operational characteristics	
Fluid	Filtered air. No lubrication needed, if applied it shall be continuous
Max working pressure (bar)	2,5 ÷ 10
Temperature °C	-5 ÷ +70
Flow rate at 6 bar with Δp=1 (NI/min)	100

SEALS	
Ⓒ R	= NBR
VR	= FPM

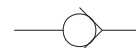
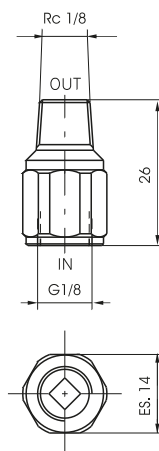

Weight 50 g

**Non return valve**

Coding: 6.07.Ⓙ

Operational characteristics	
Fluid	Filtered air. No lubrication needed, if applied it shall be continuous
Max working pressure (bar)	10
Temperature °C	-5 ÷ +70 (+150°C FPM)

SEALS	
05	= NBR-M5
18	= NBR-G1/8"
14	= NBR-G1/4"
38	= NBR-G3/8"
12	= NBR-G1/2"
18V	= FPM-G1/8"
14V	= FPM-G1/4"
38V	= FPM-G3/8"
12V	= in FPM-G1/2"

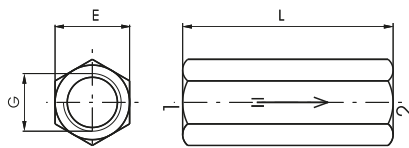

	G	M5	1/8"	1/4"	3/8"	1/2"
E	10	14	17	21	25	
L	21	37	48	50	60	
Weight g	14	35	60	85	136	
Flow rate at 6 bar with Δp = 1	NI/min.	160	650	1150	2600	3500



Weight "see table"

**Manifold 4 ports**

Coding: 6.08.Ⓒ/4

Operational characteristics	
Fluid	Filtered air. No lubrication needed, if applied it shall be continuous
Max working pressure (bar)	20
Temperature °C	-5 ÷ +70

WORKING PORTS SIZE	
05	= M5
18	= G1/8"
14	= G1/4"
38	= G3/8"
12	= G1/2"

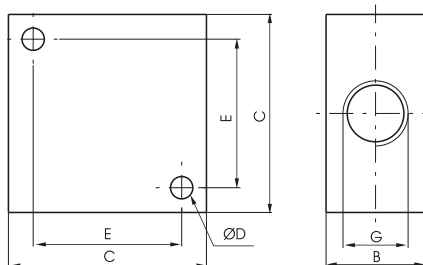
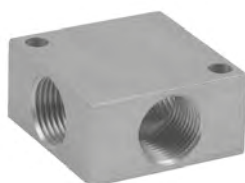

	G	M5	1/8"	1/4"	3/8"	1/2"
B	10	16	20	20	30	
C	20	32	40	40	50	
D	3,3	4,5	4,5	5,5	6,5	
E	14	22	30	30	38	
Weight g	28	38	68	54	135	

Weight "see table"



**Manifold 10 ports**

Coding: 6.08.Ⓒ/8

Operational characteristics	
Fluid	Filtered air. No lubrication needed, if applied it shall be continuous
Max working pressure (bar)	20
Temperature °C	-5 ÷ +70

WORKING PORTS SIZE	
05	= M5
18	= G1/8"
14	= G1/4"
38	= G3/8"
12	= G1/2"

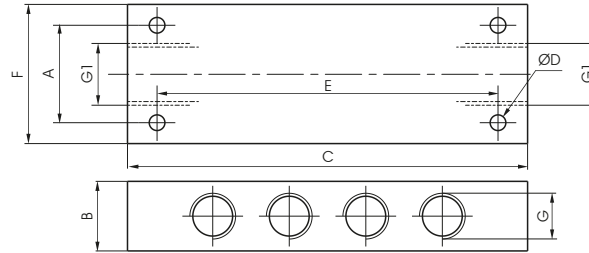

G	M5	1/8"	1/4"	3/8"	1/2"
G1	G1/8"	1/8"	1/4"	3/8"	1/2"
A	16	20	28	28	36
B	12	18	20	20	30
C	60	90	115	130	170
ØD	3,3	4,5	4,5	5,5	5,5
E	50	75	98	112	150
F	22	32	40	40	50
Weight g	92	110	185	165	460

Weight \*see table"



AIR DISTRIBUTION

**Block valve G1/4"**

Coding: 6.09.14.Ⓕ

Operational characteristics	
Fluid	Filtered air. No lubrication needed, if applied it shall be continuous
Max working pressure (bar)	10
Maximum piloting pressure (bar)	4
Temperature °C	-5 ÷ +70
Flow rate at 6 bar with Δp=1 (NI/min)	700
Orifice size (mm)	7

FUNCTION	
UN	= Unidirectional
BN	= Bidirectional

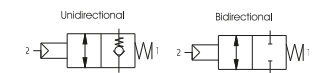
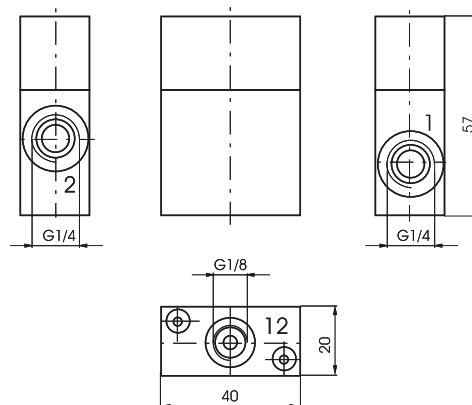

Weight 122 g

**Block valve G1/2"**

Coding: 6.09.12.Ⓕ

Operational characteristics	
Fluid	Filtered air. No lubrication needed, if applied it shall be continuous
Max working pressure (bar)	10
Maximum piloting pressure (bar)	4
Temperature °C	-5 ÷ +70
Flow rate at 6 bar with Δp=1 (NI/min)	2000
Orifice size (mm)	12

FUNCTION	
UN	= Unidirectional
BN	= Bidirectional

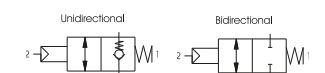
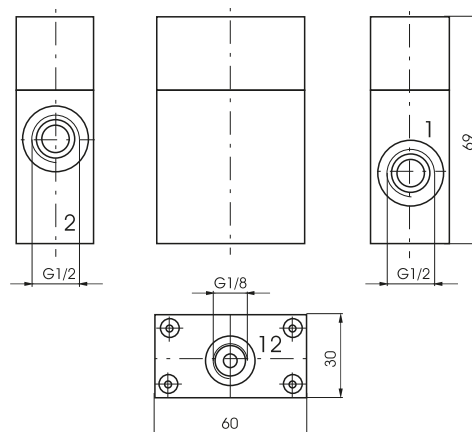

Weight 305 g

**Economizer**

Coding: 6.11.ⓐ

Operational characteristics	
Fluid	Filtered air. No lubrication needed, if applied it shall be continuous
Max working pressure (bar)	10
Pressure range (bar)	0 ÷ 5,5
Temperature °C	-5 ÷ +70
Flow rate at 6 bar with Δp=1 (NI/min)	860
Orifice size (mm)	6

WORKING PORTS SIZE	
ⓐ	18 = G1/8"
	14 = G1/4"

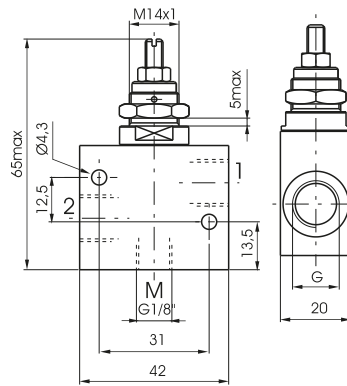

FLOW RATE CURVES  
FROM 1 TO 2

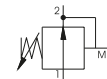
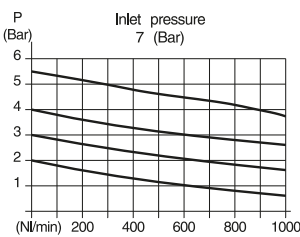

Weight 85 g



Gang mounting manifold for valves and solenoid valves G1/8"

Coding: 6.10.18. S/P

VALVE SIZE	
18	= 18 mm
25	= 25 mm
<b>S</b> 26	= 26 mm
30	= 30 mm
32	= 32 mm
35	= 35 mm
N. POSITIONS	
2	= N. 2 positions
3	= N. 3 positions
4	= N. 4 positions
<b>P</b> 5	= N. 5 positions
6	= N. 6 positions
7	= N. 7 positions
8	= N. 8 positions
9	= N. 9 positions
10	= N. 10 positions

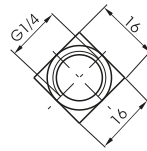
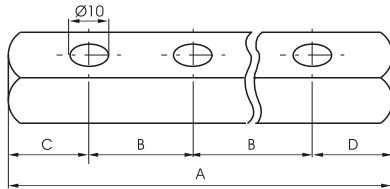

	N. OF POSITIONS									
	2	3	4	5	6	7	8	9	10	
A	58	76	94	112	130	148	166	184	202	
B	18	18	18	18	18	18	18	18	18	
C	20	20	20	20	20	20	20	20	20	
D	20	20	20	20	20	20	20	20	20	
Weight g	55	80	105	130	155	180	205	230	255	

6.10.18.18/P  
Weight \*see table"

	N. OF POSITIONS									
	2	3	4	5	6	7	8	9	10	
A	70	95	120	145	170	195	220	245	270	
B	25	25	25	25	25	25	25	25	25	
C	20	20	20	20	20	20	20	20	20	
D	25	25	25	25	25	25	25	25	25	
Weight g	80	115	150	185	220	255	290	325	360	

6.10.18.25/P  
Weight \*see table"

	N. OF POSITIONS									
	2	3	4	5	6	7	8	9	10	
A	66	92	118	144	170	196	222	248	274	
B	26	26	26	26	26	26	26	26	26	
C	20	20	20	20	20	20	20	20	20	
D	20	20	20	20	20	20	20	20	20	
Weight g	70	110	145	185	220	260	300	340	375	

6.10.18.26/P  
Weight \*see table"

	N. OF POSITIONS									
	2	3	4	5	6	7	8	9	10	
A	80	110	140	170	200	230	260	290	320	
B	30	30	30	30	30	30	30	30	30	
C	25	25	25	25	25	25	25	25	25	
D	25	25	25	25	25	25	25	25	25	
Weight g	100	140	180	220	260	300	340	380	420	

6.10.18.30/P  
Weight \*see table"

	N. OF POSITIONS									
	2	3	4	5	6	7	8	9	10	
A	82	114	146	178	210	242	274	306	338	
B	32	32	32	32	32	32	32	32	32	
C	25	25	25	25	25	25	25	25	25	
D	25	25	25	25	25	25	25	25	25	
Weight g	100	145	190	235	280	325	370	415	460	

6.10.18.32/P  
Weight \*see table"

	N. OF POSITIONS									
	2	3	4	5	6	7	8	9	10	
A	89	124	159	194	229	264	299	334	369	
B	35	35	35	35	35	35	35	35	35	
C	27	27	27	27	27	27	27	27	27	
D	27	27	27	27	27	27	27	27	27	
Weight g	110	160	210	260	310	360	410	460	510	

6.10.18.35/P  
Weight \*see table"

1 AIR DISTRIBUTION



**Gang mounting manifold for valves and solenoid valves G1/4"**

Coding: 6.10.14.S/P

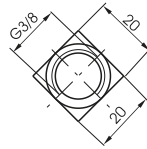
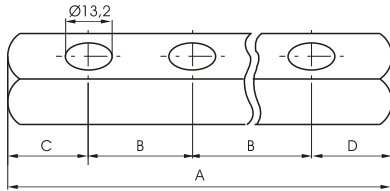

S	VALVE SIZE
	20 = 20 mm
	25 = 25 mm
	30 = 30 mm
	35 = 35 mm
P	N. POSITIONS
	2 = N. 2 positions
	3 = N. 3 positions
	4 = N. 4 positions
	5 = N. 5 positions
	6 = N. 6 positions
	7 = N. 7 positions
	8 = N. 8 positions
	9 = N. 9 positions
	10 = N. 10 positions

1  
AIR DISTRIBUTION

	N. OF POSITIONS									
	2	3	4	5	6	7	8	9	10	
A	65	85	105	125	145	165	185	205	225	
B	20	20	20	20	20	20	20	20	20	
C	22,5	22,5	22,5	22,5	22,5	22,5	22,5	22,5	22,5	
D	22,5	22,5	22,5	22,5	22,5	22,5	22,5	22,5	22,5	
Weight g	130	150	190	190	210	230	250	270	290	

6.10.14.20/P  
Weight "see table"

	N. OF POSITIONS									
	2	3	4	5	6	7	8	9	10	
A	75	100	125	150	175	200	225	250	275	
B	25	25	25	25	25	25	25	25	25	
C	25	25	25	25	25	25	25	25	25	
D	25	25	25	25	25	25	25	25	25	
Weight g	140	170	200	230	260	290	320	350	380	

6.10.14.25/P  
Weight "see table"

	N. OF POSITIONS									
	2	3	4	5	6	7	8	9	10	
A	80	110	140	170	200	230	260	290	320	
B	30	30	30	30	30	30	30	30	30	
C	25	25	25	25	25	25	25	25	25	
D	25	25	25	25	25	25	25	25	25	
Weight g	150	190	230	270	310	350	390	430	470	

6.10.14.30/P  
Weight "see table"

	N. OF POSITIONS									
	2	3	4	5	6	7	8	9	10	
A	85	120	155	190	225	260	295	335	365	
B	35	35	35	35	35	35	35	35	35	
C	30	30	30	30	30	30	30	30	30	
D	20	20	20	20	20	20	20	20	20	
Weight g	160	210	260	310	360	410	460	510	560	

6.10.14.35/P  
Weight "see table"

	N. OF POSITIONS									
	2	3	4	5	6	7	8	9	10	
A	115	160	205	250	295	340	385	430	475	
B	45	45	45	45	45	45	45	45	45	
C	35	35	35	35	35	35	35	35	35	
D	35	35	35	35	35	35	35	35	35	
Weight g	200	275	350	425	500	575	650	725	800	

6.10.14.45/P  
Weight "see table"

**Spry valves**

Coding: 6.13.00

**Construction characteristics**

- This valve, is based on the Venturi principle, and it is used to spray and nebulize a liquid.
- Useful in all applications where is needed a continuous lubrication and / or refrigeration.
- Incoming air (connection 1) sucks the liquid through the venturi principle (connection 3) to obtain a continuous spray output (connection 2).

Technical characteristics	
Fluid	Filtered air. No lubrication needed, if applied it shall be continuous
Liquid	Water and oil (Liquid viscosity 3°E-5°E)
Working pressure (bar)	3 ÷ 10
Temperature °C	-5 ÷ +70
Weight (g)	85

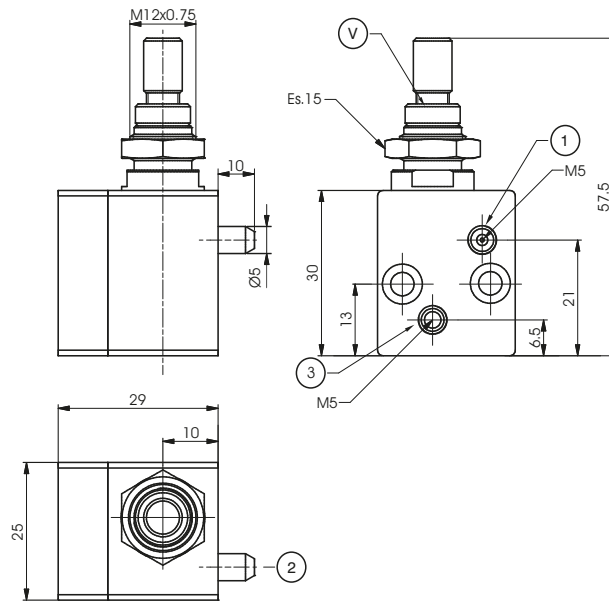

**Liquid consumption diagram**

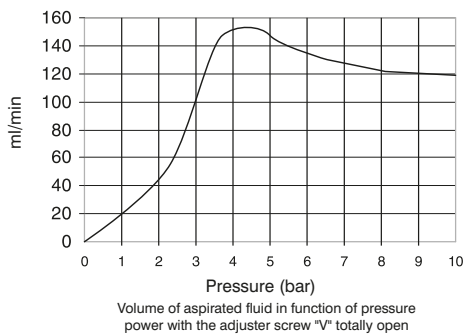

**Vacuum diagram**

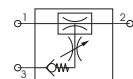
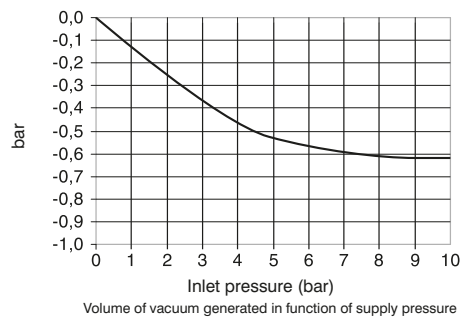

Supply air : Connection 1  
Output (air and nebulized liquid) : Connection 2  
Supply liquid : Connection 3

1 AIR DISTRIBUTION





## Series 900

### General

The 900 series consist of the following components:

- Pressure switch, which transforms a pneumatic signal into an electric one.
- Impulse generator, which transforms a permanent pneumatic signal into an adjustable impulse from 0 to 10 seconds.
- Pneumatic timer (N.C. or N.O.), which cuts or releases a pneumatic signal within an adjustable time.
- Two hands safety valve, which allows a safety use of two hands pneumatic controls (for example two push-button 3/2 N.C. to a certain distance) excluding false signals in case of push-button or valve malfunction.
- Flip - Flop: 5/2 ways valve, single signal actuated, commutes the outlet from 2 to 4 and vice versa at each puls.
- For a correct functioning it's important that inlet pressure be the same or lower than pilot pressure.
- Oscillator valve, 5/2 - G 1/8" with two logic functions "NOT" mounted on board, switches when the pressure in the connected cylinder exhaust chamber is reaching the threshold of "NOT".
- Signal amplifier, 3/2 - G 1/8" N.C. valve actuated by weak signals but higher than 0.05 bar.
- Progressive start-up valve, which is a device that is fitted in between valve or solenoid valve and cylinder allows a gradual filling of the chamber providing a low power cylinder movement. The progressive start-up valve is made of a flow control valve and a 2/2 N.C. valve with 6 mm nominal orifice. The valve is totally open when the pressure in the cylinder reaches 50% of inlet pressure.
- High-low pressure devices, located in the pneumatic circuit between valve and cylinder, allow the function of the cylinder with two different pressures. Example: in case of a locking action, it is possible to approach the required position at a low pressure, then increase to its maximum value in the circuit with the use of an electric signal. They are practically made of a piloted pressure regulator without relieving.

### Construction characteristics

We use corrosion proof material, brass or anodized aluminium and the most appropriate specific mixture for seals. If more information is required please contact our technical department.

### Use and maintenance

In use pay attention to the minimum and maximum criteria for temperature and pressure, checking and ensure good quality compressed air. In a dirty environment, protect the exhaust ports. In this case, maintenance is minimal and is necessary only if the air is particularly dirty. This simple operation it should be carried out by a competent person.

**ATTENTION:** use hydraulic oil class H for lubrication such as MAGNA GC 32 (Castrol).

► Pressure switch G 1/8" - screw connections

Coding: 900.18.1-**P**

Operational characteristics	
Fluid	Filtered air. No lubrication needed, if applied it shall be continuous
Max working pressure (bar)	10
Temperature °C	-5 ÷ +70
Flow rate microswitch	13 (3) A to 220V~
Pilot ports size	G1/8"

PRESSURE	
<b>P</b>	1 = Min. switch pressure 1 bar
	4 = Min. switch pressure 4 bar

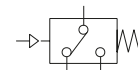
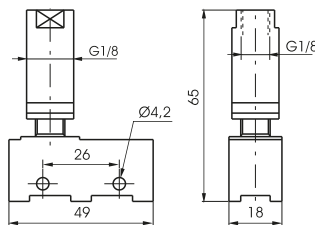

Weight 75 g

► Pressure switch G 1/8" - spade connections

Coding: 900.18.1/**P**

Operational characteristics	
Fluid	Filtered air. No lubrication needed, if applied it shall be continuous
Max working pressure (bar)	10
Temperature °C	-5 ÷ +70
Flow rate microswitch	16 (5) A to 220V~
Pilot ports size	G1/8"

PRESSURE	
<b>P</b>	1 = Min. switch pressure 1 bar
	4 = Min. switch pressure 4 bar

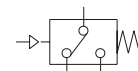
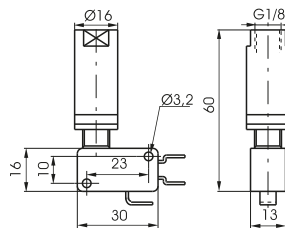

Weight 60 g

► Switch protection

Coding: 900.18.0

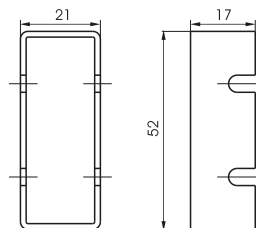

Weight 6 g

► Impulse generator

Coding: 900.18.2N

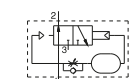
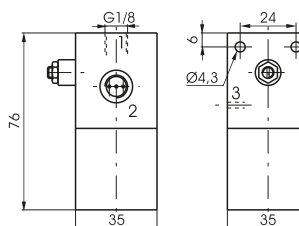

Weight 325 g

**Pneumatic timer N.C. - G 1/8"**

Coding: 900.18.T

Operational characteristics	
Fluid	Filtered air. No lubrication needed, if applied it shall be continuous
Max working pressure (bar)	3 ÷ 10
Temperature °C	-5 ÷ +70
Flow rate at 6 bar with Δp=1 (NI/min)	130
Orifice size (mm)	2.5

TIME	
① 3 =	0 ÷ 30 sec.
3-60 =	0 ÷ 60 sec.

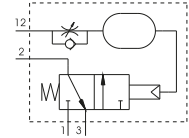
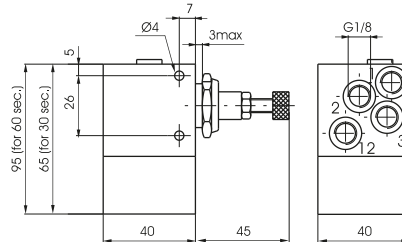

Weight 290 (30 sec.) g  
weight 350 g (60 sec.)

**Pneumatic timer N.O. - G 1/8"**

Coding: 900.18.T

Operational characteristics	
Fluid	Filtered air. No lubrication needed, if applied it shall be continuous
Max working pressure (bar)	4 ÷ 10
Temperature °C	-5 ÷ +70
Flow rate at 6 bar with Δp=1 (NI/min)	130
Orifice size (mm)	2.5

TIME	
① 4 =	0 ÷ 30 sec.
4-60 =	0 ÷ 60 sec.

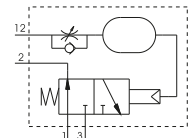
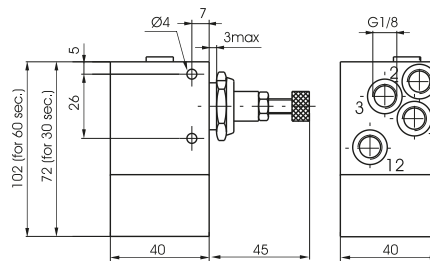

Weight 320 (30 sec.) g  
weight 380 g (60 sec.)

**Two hands safety valve G 1/4"**

Coding: 900.52.1.1

Operational characteristics	
Fluid	Filtered air. No lubrication needed, if applied it shall be continuous
Max working pressure (bar)	10
Temperature °C	-5 ÷ +70
Flow rate at 6 bar with Δp=1 (NI/min)	1030
Orifice size (mm)	7
Working ports size	G1/4"
Pilot ports size	G1/8"

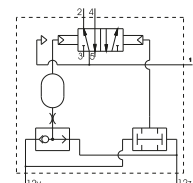
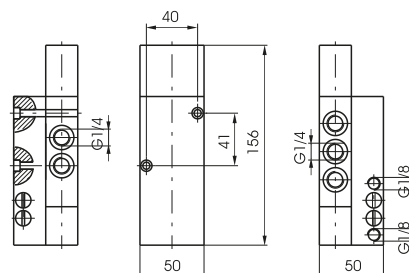

Weight 780 g



1  
AIR DISTRIBUTION

**Two hands safety valve III A class certification (according to EN 574 standard)**

Coding: 900.18.9

Operational characteristics	
Fluid	Filtered air. No lubrication needed, if applied it shall be continuous
Max working pressure (bar)	3 ÷ 8
Temperature °C	-5 ÷ +70
Flow rate at 6 bar with Δp=1 (NI/min)	40
Orifice size (mm)	2.5
Working ports size	G1/8"
Pilot ports size	G1/8"

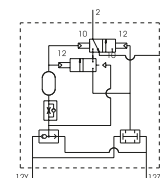
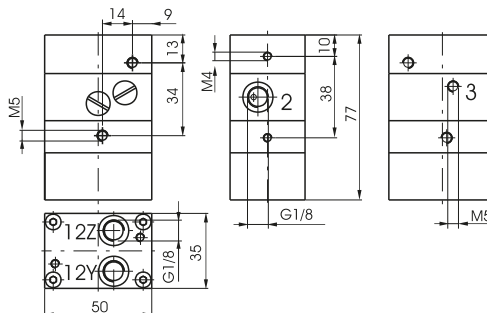

Weight 340 g

**Two hands safety valve III B class certification (according to EN 574 standard)**

Coding: 900.18.10

Operational characteristics	
Fluid	Filtered air. No lubrication needed, if applied it shall be continuous
Max working pressure (bar)	3 ÷ 8
Temperature °C	-5 ÷ +70
Flow rate at 6 bar with Δp=1 (NI/min)	40
Orifice size (mm)	2.5
Working ports size	G1/8"
Pilot ports size	G1/8"

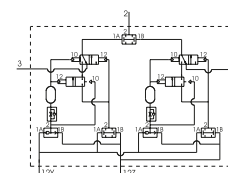
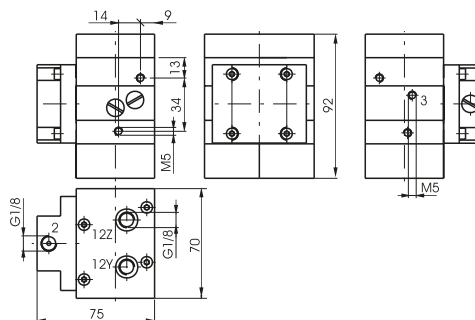

Weight 980 g

**Power valve adaptor (Series 2400)**

Coding: 900.18.11

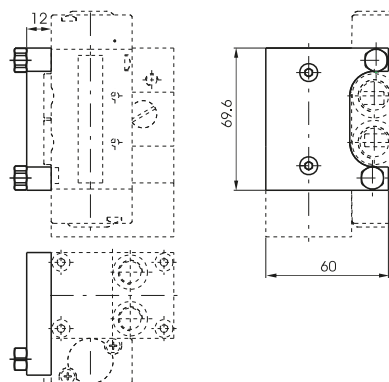

Weight 75 g

### Flip-flop valve G 1/8" - Pneumatic command

Coding: 900.52.1.3

Operational characteristics	
Fluid	Filtered air. No lubrication needed, if applied it shall be continuous
Max working pressure (bar)	10
Temperature °C	-5 ÷ +70
Flow rate at 6 bar with Δp=1 (NI/min)	540
Orifice size (mm)	6
Working ports size	G1/8"

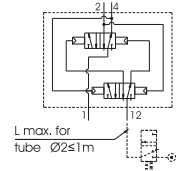
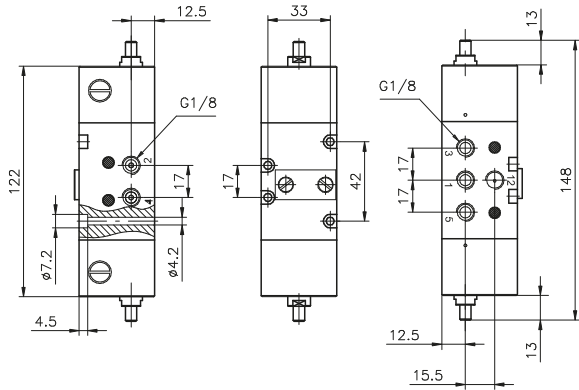

Weight 550 g

Attention : Pressure of signal "12" must be the same or higher than device inlet pressure. The maximum distance between the pilot valve and the device must not exceed 1Mtr. (see pneumatic scheme). Should be necessary to work at a greater distance it is advisable to use a pneumatic-spring shut-off valve positioned at the recommended distance.

### Flip-flop valve - Electric command with M2 mechanic

Coding: 900.52.1.4

Operational characteristics	
Fluid	Filtered air. No lubrication needed, if applied it shall be continuous
Max working pressure (bar)	10
Temperature °C	-5 ÷ +70
Flow rate at 6 bar with Δp=1 (NI/min)	540
Orifice size (mm)	6
Working ports size	G1/8"

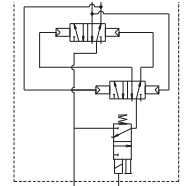
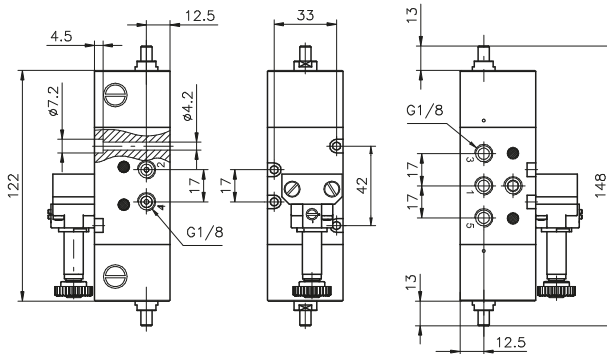

Weight 660 g

### Flip-flop valve - Electric command with M3P CNOMO

Coding: 900.52.1.5

Operational characteristics	
Fluid	Filtered air. No lubrication needed, if applied it shall be continuous
Max working pressure (bar)	10
Temperature °C	-5 ÷ +70
Flow rate at 6 bar with Δp=1 (NI/min)	540
Orifice size (mm)	6
Working ports size	G1/8"

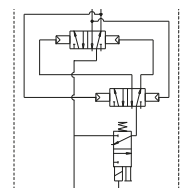
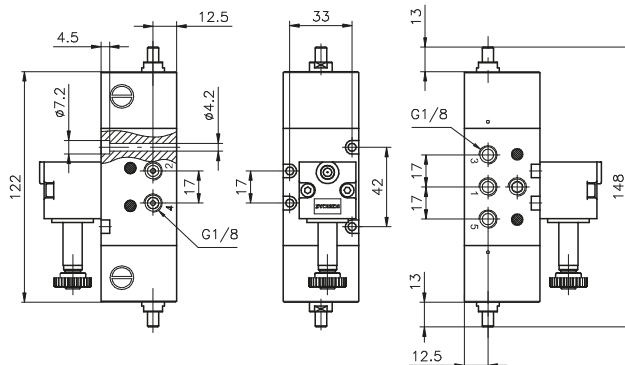

Weight 600 g

**Oscillator valve G 1/8"**

Coding: 900.52.6

Operational characteristics	
Fluid	Filtered air. No lubrication needed, if applied it shall be continuous
Max working pressure (bar)	8
Min working pressure	2
Temperature °C	-5 ÷ +70
Flow rate at 6 bar with Δp=1 (NI/min)	540
Orifice size (mm)	6
Working ports size	G1/8"

FUNCTION	
F	5 = without logic functions NOT
	5C = with logic functions NOT

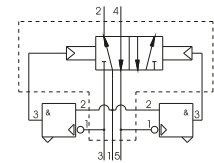
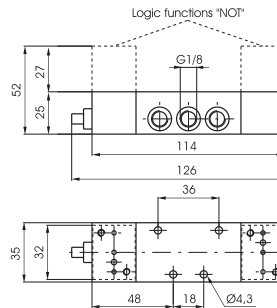

Weight 600 g

**Signal amplifier G 1/8"**

Coding: 900.32.6

Operational characteristics	
Fluid	Filtered air. No lubrication needed, if applied it shall be continuous
Max working pressure (bar)	10
Min working pressure	0.05
Temperature °C	-5 ÷ +70
Flow rate at 6 bar with Δp=1 (NI/min)	130
Orifice size (mm)	3
Working ports size	G1/8"

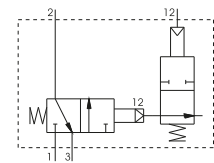
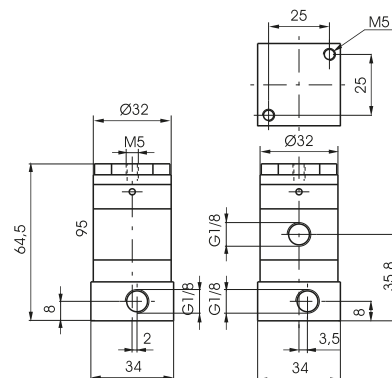

Weight 170 g

**Progressive start-up valve G 1/4"**

Coding: 900.14.7

Operational characteristics	
Fluid	Filtered air. No lubrication needed, if applied it shall be continuous
Max working pressure (bar)	2,5 ÷ 10
Temperature °C	-5 ÷ +70
Flow rate from 1 to 2 (NI/min)	760
Flow rate from 2 to 1 (NI/min)	900
Orifice size (mm)	6

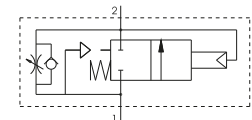
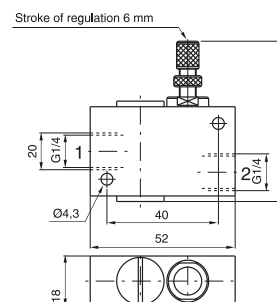

Weight 100 g  
Flow rate needle fully open from port 1 to 2 (NI/min.) = 200

High-low pressure device

Coding: 900.18.8.P

Operational characteristics	
Fluid	Filtered air. No lubrication needed, if applied it shall be continuous
Max working pressure (bar)	10
Pressure range (bar)	1 ÷ 4
Temperature °C	-5 ÷ +50
Flow rate at 6 bar with $\Delta p=1$ (NI/min)	650
Working ports size	G1/8"

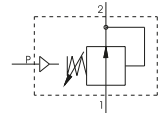
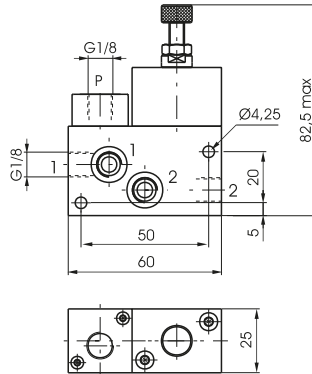

Weight 240 g  
with pneumatic pilot

High-low pressure device

Coding: 900.18.8.E

Operational characteristics	
Fluid	Filtered air. No lubrication needed, if applied it shall be continuous
Max working pressure (bar)	10
Pressure range (bar)	1 ÷ 4
Temperature °C	-5 ÷ +50
Flow rate at 6 bar with $\Delta p=1$ (NI/min)	650
Working ports size	G1/8"

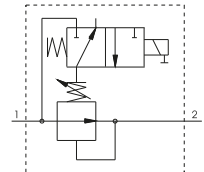
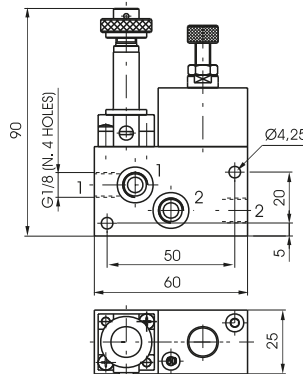

Weight 280 g  
with M2 mechanic

External feeding base "NOT" logical element

Coding: 900.005

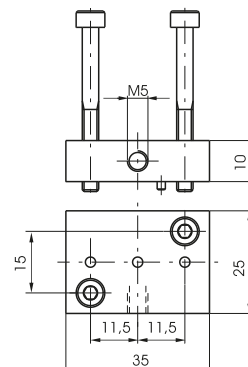

Weight 35 g

1  
AIR DISTRIBUTION

Pneumatic glue injector

Coding: 900.19.01

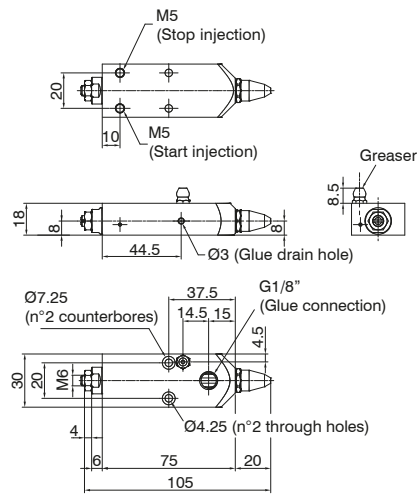

1  
AIR DISTRIBUTION

**Construction characteristics**

- External components: nickel-plated brass / stainless steel
- Piloting connections: M5
- Glue connection: G1/8"
- Glue Seal: special PTFE
- Pneumatic seals: NBR
- Grease nipple: Stainless steel
- Spray intensity adjustment screw: Stainless steel

**Technical characteristics**

Technical characteristics	
Injection fluid	Vinyl glue
Pressure Glue (bar)	7
Pneumatic fluid piloting	Filtered air. No lubrication needed, if applied it shall be continuous
Opening pilot (bar)	3 ÷ 6
Closing pilot (bar)	3 ÷ 6 (or spring)
Temperature °C	-5 ÷ +70
Weight (g)	285



## Series 50

### General

The blocking valves are used to maintain pressure in the downstream part of the pneumatic circuit even when the pressure supply is shut down.

Blocking valves are normally assembled directly on cylinders ports in order to maintain the position even in cases of accidental loss of the pilot pressure by preventing a sudden loss of pressure in the cylinder chambers.

Unidirectional and bidirectional version are both available.

The unidirectional version allows free air to flow in one direction while requires a pneumatic signal to allow air flow in the opposite direction.

The bidirectional version requires a pressure signal to allow air flow in both of the two directions.

**The blocking valve cannot be used as safety device.**

### Constructive features

#### UNIDIRECTIONAL VERSION

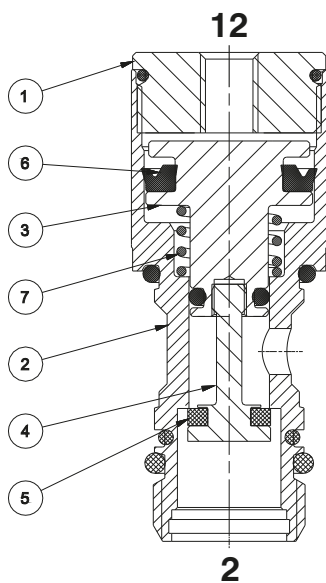
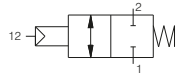

- 1 - Aluminium piston
- 2 - Brass plug
- 3 - Brass body
- 4 - FPM poppet (1/8" and 1/4" version) PUR poppet
- 5 - NBR seal
- 6 - Steel spring

#### BIDIRECTIONAL VERSION

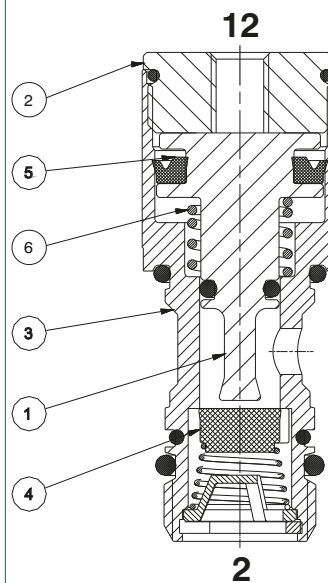
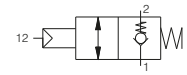

- 1 - Brass plug
- 2 - Brass body
- 3 - Aluminium piston
- 4 - Steel piston extension
- 5 - PUR poppet
- 6 - NBR seal
- 7 - Steel spring

### Working curves

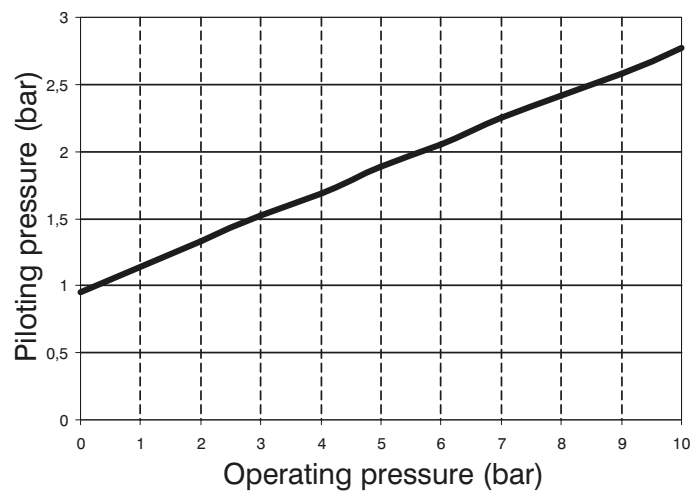

**Blocking valves metal type - Size 1/8"**

Coding: 50**T**18**V**

Operational characteristics	
Fluid	Filtered air. No lubrication needed, if applied it shall be continuous
Max working pressure (bar)	0,5 ÷ 10
Temperature °C	-5 ÷ +50
Flow rate at 6 bar with Δp=1 (NI/min)	285
Flow rate with free exhaust (NI/min)	450

<b>T</b>	METAL TYPE
	<b>A</b> = Banjo only
	<b>04</b> = Banjo Ø4
	<b>06</b> = Banjo Ø6
	<b>08</b> = Banjo Ø8
	<b>18</b> = Banjo G1/8"
<b>V</b>	VERSION
	<b>U</b> = Unidirectional
	<b>B</b> = Bidirectional

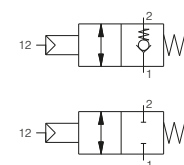
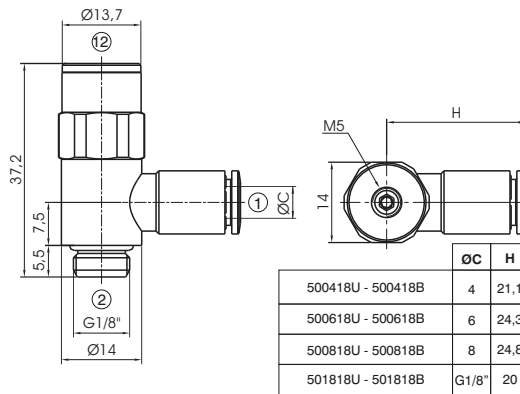

**Blocking valves metal type - Size 1/4"**

Coding: 50**T**14**V**

Operational characteristics	
Fluid	Filtered air. No lubrication needed, if applied it shall be continuous
Max working pressure (bar)	0,5 ÷ 10
Temperature °C	-5 ÷ +50
Flow rate at 6 bar with Δp=1 (NI/min)	530
Flow rate with free exhaust (NI/min)	800

<b>T</b>	METAL TYPE
	<b>A</b> = Banjo only
	<b>06</b> = Banjo Ø6
	<b>08</b> = Banjo Ø8
	<b>10</b> = Banjo Ø10
	<b>14</b> = Banjo G1/4"
<b>V</b>	VERSION
	<b>U</b> = Unidirectional
	<b>B</b> = Bidirectional

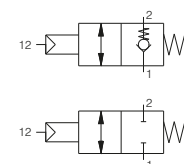
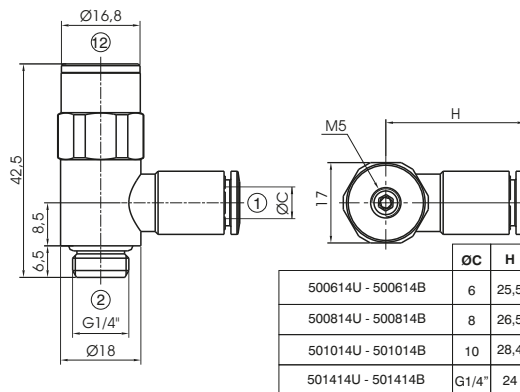

**Blocking valves metal type - Size 3/8"**

Coding: 50**T**38**V**

Operational characteristics	
Fluid	Filtered air. No lubrication needed, if applied it shall be continuous
Max working pressure (bar)	0,5 ÷ 10
Temperature °C	-5 ÷ +50
Flow rate at 6 bar with Δp=1 (NI/min)	1000
Flow rate with free exhaust (NI/min)	1600

<b>T</b>	METAL TYPE
	<b>A</b> = Banjo only
	<b>08</b> = Banjo Ø8
	<b>10</b> = Banjo Ø10
	<b>12</b> = Banjo Ø12
	<b>38</b> = Banjo G3/8"
<b>V</b>	VERSION
	<b>U</b> = Unidirectional
	<b>B</b> = Bidirectional

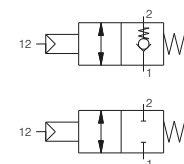
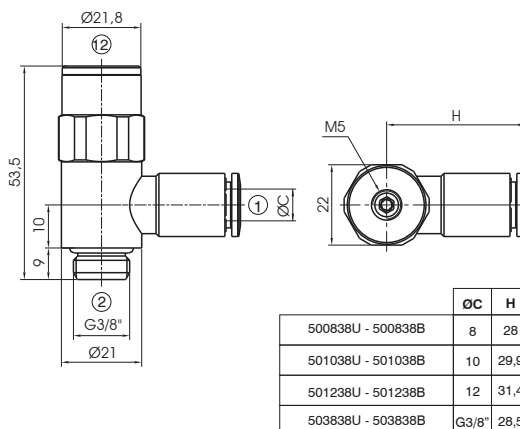

Blocking valves metal type - Size 1/2"

Coding: 50 **T** 12 **V**

Operational characteristics	
Fluid	Filtered air. No lubrication needed, if applied it shall be continuous
Max working pressure (bar)	0,5 ÷ 10
Temperature °C	-5 ÷ +50
Flow rate at 6 bar with $\Delta p=1$ (NI/min)	1300
Flow rate with free exhaus (NI/min)	2600

METAL TYPE	
<b>T</b>	A = Banjo only
	12 = Banjo Ø12
	G12 = Banjo G1/2"
VERSION	
<b>V</b>	U = Unidirectional
	B = Bidirectional

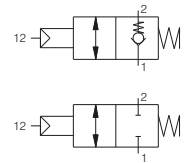
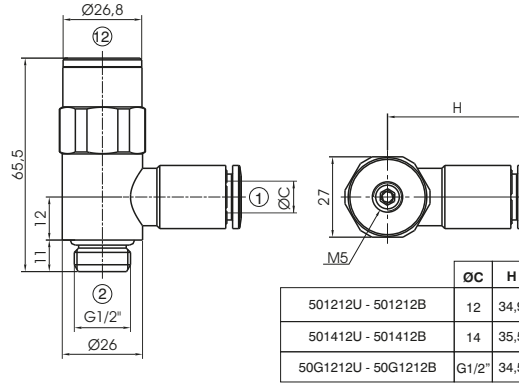

1  
AIR DISTRIBUTION



AIR DISTRIBUTION

**Blocking valves technopolymer type - Size 1/8"**

Coding: T50**T**18**V**

Operational characteristics	
Fluid	Filtered air. No lubrication needed, if applied it shall be continuous
Max working pressure (bar)	0,5 ÷ 10
Temperature °C	-5 ÷ +50
Flow rate at 6 bar with Δp=1 (NI/min)	285
Flow rate with free exhaus (NI/min)	450

METAL TYPE	
<b>A</b>	= Banjo only
<b>T</b> 04	= Banjo Ø4
06	= Banjo Ø6
08	= Banjo Ø8
VERSION	
<b>V</b> U	= Unidirectional
B	= Bidirectional

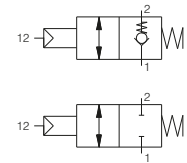
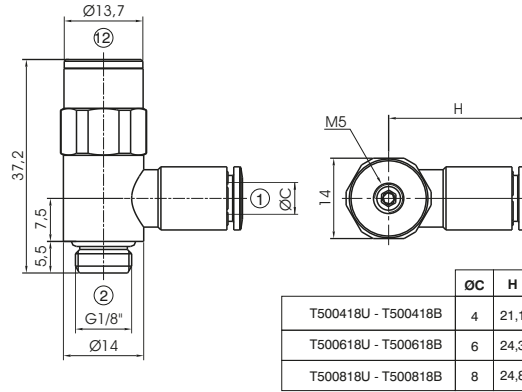

**Blocking valves technopolymer type - Size 1/4"**

Coding: T50**T**14**V**

Operational characteristics	
Fluid	Filtered air. No lubrication needed, if applied it shall be continuous
Max working pressure (bar)	0,5 ÷ 10
Temperature °C	-5 ÷ +50
Flow rate at 6 bar with Δp=1 (NI/min)	530
Flow rate with free exhaus (NI/min)	800

METAL TYPE	
<b>A</b>	= Banjo only
<b>T</b> 06	= Banjo Ø6
08	= Banjo Ø8
10	= Banjo Ø10
VERSION	
<b>V</b> U	= Unidirectional
B	= Bidirectional

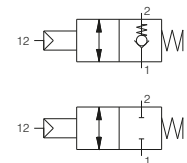
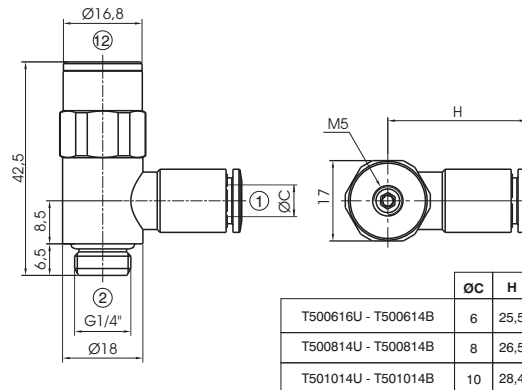

**Blocking valves technopolymer type - Size 3/8"**

Coding: T50**T**38**V**

Operational characteristics	
Fluid	Filtered air. No lubrication needed, if applied it shall be continuous
Max working pressure (bar)	0,5 ÷ 10
Temperature °C	-5 ÷ +50
Flow rate at 6 bar with Δp=1 (NI/min)	1000
Flow rate with free exhaus (NI/min)	1600

METAL TYPE	
<b>A</b>	= Banjo only
<b>T</b> 08	= Banjo Ø8
10	= Banjo Ø10
12	= Banjo Ø12
VERSION	
<b>V</b> U	= Unidirectional
B	= Bidirectional

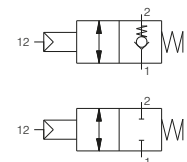
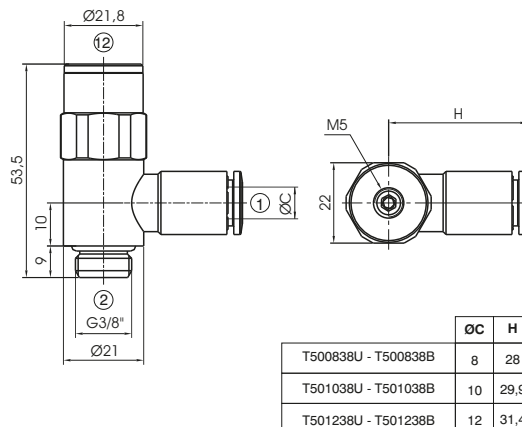



Blocking valves technopolymer type - Size 1/2"

Coding: T50<sup>①</sup>12<sup>②</sup>V

Operational characteristics	
Fluid	Filtered air. No lubrication needed, if applied it shall be continuous
Max working pressure (bar)	0,5 ± 10
Temperature °C	-5 ± +50
Flow rate at 6 bar with Δp=1 (NI/min)	1300
Flow rate with free exhaus (NI/min)	2600

METAL TYPE	
①	A = Banjo only
	10 = Banjo Ø10
	12 = Banjo Ø12
VERSION	
②	U = Unidirectional
	B = Bidirectional

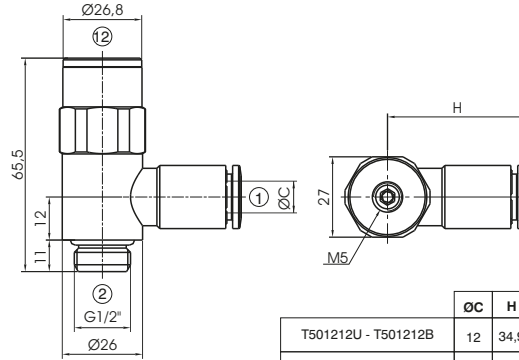

	ØC	H
T501212U - T501212B	12	34.9
T501012U - T501012B	10	30

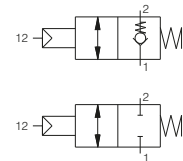

1  
AIR DISTRIBUTION

## Series 55 Tecno-FUN

### General

This line of different logic functions that can be used in any place of the secondary pneumatic circuit, developed to be installed directly onto the main pneumatic components (distributors or cylinders).

Thanks to the modular design it is possible to easily join together multiple logic functions without the need of using pipes to connect them; it is also possible to choose the type and style of each connection. The connections available are the following: straight cartridge; Banjo PL cartridge; male cartridge threaded 1/8" or 1/4" and female cartridge threaded 1/8".

Function fittings can also be assembled side by side in order to be assembled on the DIN EN 50022 rail (using the relevant kit).



### Other characteristics:

Technopolymer body  
Input/output connection directly integrated into the body  
In line or 90° connection  
Possibility to build a manifold -parallel mounting-  
Different connection options:  
Tube Ø4 Ø6 Ø8 (elbow version as well)  
G1/8" G1/4" male straight cartridge  
G1/8" female cartridge, in line or 90°

### Different mounting options:

- Wall fixing through the holes in the body
- By means of the fixing bracket
- Panel mounting (for those function that include such possibility)
- On DIN rail EN 50022 (using the DIN rail adapter kit)

### Available functions

- Flow control valve
- Pressure regulator
- Block valve
- Quick exhaust valve
- OR gate
- AND gate
- Pressure gauge
- Progressive start-up valve
- Pressure regulator + pressure gauge
- Block valve + Flow control valve
- Block valve + quick exhaust valve

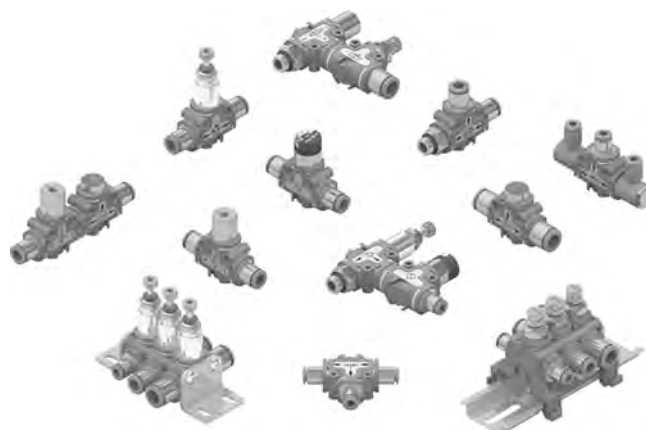

Flow regulator

Coding: 551.11 T A B XX

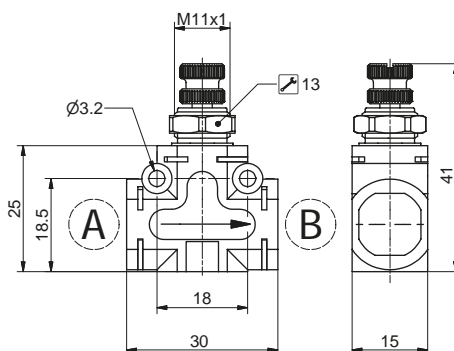

TYPE	
<b>T</b>	1 = Unidirectional 2 = Bidirectional
CONNECTION A <b>SEE CONNECTIONS LIST</b>	
CONNECTION B <b>SEE CONNECTIONS LIST</b>	
CONNECTIONS LIST	
<b>00</b>	= None
<b>D4</b>	= Straight Ø4
<b>D6</b>	= Straight Ø6
<b>D8</b>	= Straight Ø8
<b>L1</b>	= Female banjo G1/8"
<b>G4</b>	= Rotating banjo Ø 4
<b>G6</b>	= Rotating banjo Ø 6
<b>G8</b>	= Rotating banjo Ø 8
<b>M1</b>	= G1/8" male
<b>M2</b>	= G1/4" male
<b>F1</b>	= G1/8" female

Example: 551.111.D6.D6.XX  
Flow control valve unidirectional, CONNECTIONS "A" and "B" Tube Ø6  
NOTE : For the dimension including cartridges see page Accessories - Function fittings

Piloting curves

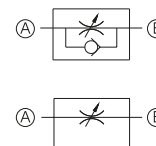
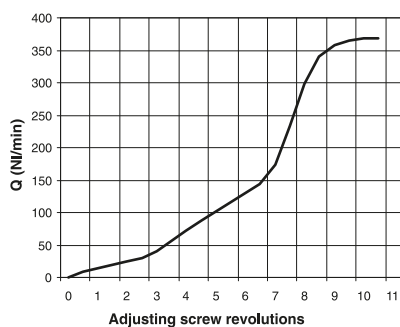

Construction characteristics

- The flow control valve is normally used to regulate the air flow and, as a consequence, for example, the speed of a cylinder. Two types of flow control valves are available: unidirectional and bidirectional. In the unidirectional valve the flow is regulated only in one direction while is free to move in the opposite direction; in the bidirectional valve the flow is regulated in both directions.
- Panel mounting using the lock nut supplied as standard
- on DIN rail using the relevant adaptor kit (see accessories)
- With 90° bracket (see accessories)
- directly on the support plate thanks to two through holes on the body

Technical characteristics

Fluid	Filtered air. No lubrication needed, if applied it shall be continuous
Working ports size	See CONNECTIONS LIST
Max working pressure (bar)	10
Orifice size (mm)	Ø3
Free exhaust flow rate in the opposite side of the regulation	800 (for unidirectional version)
Temperature °C	-5 ÷ +50
Weight (g)	26

1 AIR DISTRIBUTION

In line pressure regulator

Coding: 551.12T.A.B.XX

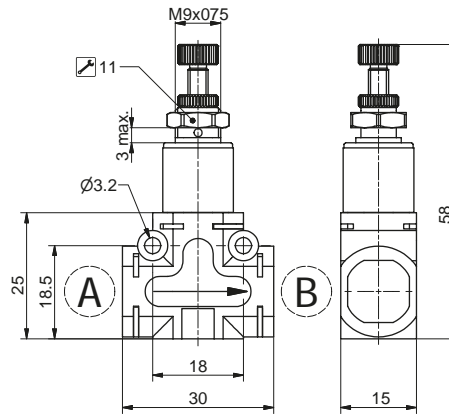

TYPE	
T	2 = 0-2 bar
	4 = 0-4 bar
	8 = 0-8 bar
CONNECTION A	
A	SEE CONNECTIONS LIST
CONNECTION B	
B	SEE CONNECTIONS LIST
CONNECTIONS LIST	
00	= None
D4	= Straight Ø4
D6	= Straight Ø6
D8	= Straight Ø8
L1	= Female banjo G1/8"
G4	= Rotating banjo Ø 4
G6	= Rotating banjo Ø 6
G8	= Rotating banjo Ø 8
M1	= G1/8" male
M2	= G1/4" male
F1	= G1/8" female

Example: 551.128.D8.D8.XX

In line pressure regulator, pressure range (bar) 0-8 bar. Connections "A" and "B" Tube Ø6  
NOTE : For the dimension including cartridges see page Accessories - Function fittings

Construction characteristics

- The pressure regulator is a device which is used to reduce, regulate and stabilize the air pressure in a conduit in order to adapt it to the needs of the equipments to be supplied. The pressure regulator incorporates the relieving function.
- Panel mounting using the lock nut supplied as standard
- on DIN rail using the relevant adaptor kit (see accessories)
- With 90° bracket (see accessories)
- directly on the support plate thanks to two through holes on the body

Technical characteristics	
Fluid	Filtered air. No lubrication needed, if applied it shall be continuous
Working ports size	See CONNECTIONS LIST
Max working pressure (bar)	10
Flow rate at 6 bar with Δp=1 (NI/min)	180
Pressure range (bar)	0÷2 / 0÷4 / 0÷8
Temperature °C	-5 ÷ +50
Weight (g)	31

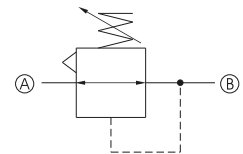

90° pressure regulator

Coding: 551.22T.A.B.XX

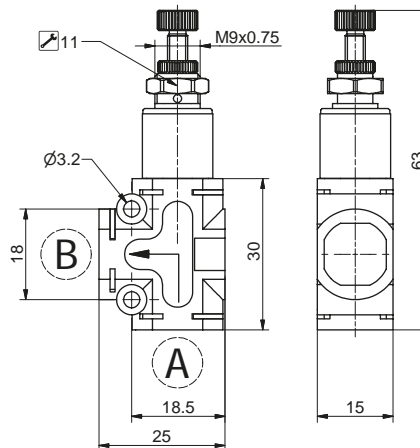

TYPE	
T	2 = 0-2 bar
	4 = 0-4 bar
	8 = 0-8 bar
CONNECTION A	
A	SEE CONNECTIONS LIST
CONNECTION B	
B	SEE CONNECTIONS LIST
CONNECTIONS LIST	
00	= None
D4	= Straight Ø4
D6	= Straight Ø6
D8	= Straight Ø8
L1	= Female banjo G1/8"
G4	= Rotating banjo Ø 4
G6	= Rotating banjo Ø 6
G8	= Rotating banjo Ø 8
M1	= G1/8" male
M2	= G1/4" male
F1	= G1/8" female

Example: 551.224.M1.D6.XX

90° pressure regulator, pressure range (bar) 0-4 bar. Connections "A" Male G1/8 and "B" Tube Ø6  
NOTE : For the dimension including cartridges see page Accessories - Function fittings

Construction characteristics

- The pressure regulator is a device which is used to reduce, regulate and stabilize the air pressure in a conduit in order to adapt it to the needs of the equipments to be supplied. The pressure regulator incorporates the relieving function.
- Panel mounting using the lock nut supplied as standard
- on DIN rail using the relevant adaptor kit (see accessories)
- With 90° bracket (see accessories)
- directly on the support plate thanks to two through holes on the body

Technical characteristics	
Fluid	Filtered air. No lubrication needed, if applied it shall be continuous
Working ports size	See CONNECTIONS LIST
Max working pressure (bar)	10
Flow rate at 6 bar with Δp=1 (NI/min)	180
Pressure range (bar)	0÷2 / 0÷4 / 0÷8
Temperature °C	-5 ÷ +50
Weight (g)	31

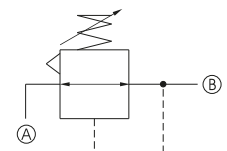



Blocking valve

Coding: 551.13T.A.B.XX

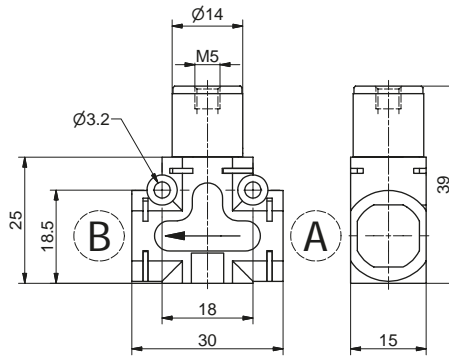

TYPE	
<b>T</b>	1 = Unidirectional 2 = Bidirectional
CONNECTION A <b>SEE CONNECTIONS LIST</b>	
CONNECTION B <b>SEE CONNECTIONS LIST</b>	
CONNECTIONS LIST	
<b>00</b>	= None
<b>D4</b>	= Straight Ø4
<b>D6</b>	= Straight Ø6
<b>D8</b>	= Straight Ø8
<b>L1</b>	= Female banjo G1/8"
<b>G4</b>	= Rotating banjo Ø 4
<b>G6</b>	= Rotating banjo Ø 6
<b>G8</b>	= Rotating banjo Ø 8
<b>M1</b>	= G1/8" male
<b>M2</b>	= G1/4" male
<b>F1</b>	= G1/8" female

Example: 551.131.D4.D4.XX  
In line blocking valve, unidirectional. Connections "A" and "B" Tube Ø4  
NOTE : For the dimension including cartridges see page Accessories - Function fittings

Piloting curves

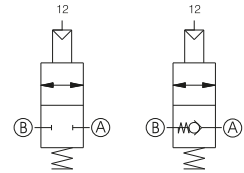
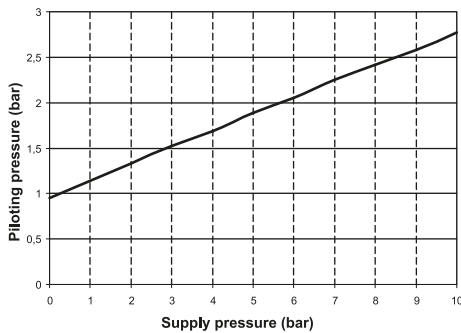

Construction characteristics

- The blocking valve function is to maintain the circuit downstream pressure in the event of loss of supply pressure. It is normally fitted directly onto the cylinder connections ports in order to ensure that, in case of accidental loss of the supply pressure, the units positions is maintained. This is achieved as the blocking valve preserves the pressure inside the pressurised chamber. Blocking valves can be unidirectional or bidirectional.
- In the unidirectional version the air flow is free in one direction while in order to allow the flow in the opposite direction is necessary to send a pneumatic signal to the unit connection 12.
- The bidirectional version requires a pneumatic signal on connection 12 to allow the flow in any of the two directions.
- on DIN rail using the relevant adaptor kit (see accessories)
- With 90° bracket (see accessories)
- directly on the support plate thanks to two through holes on the body

Technical characteristics

Fluid	Filtered air. No lubrication needed, if applied it shall be continuous
Working ports size	See CONNECTIONS LIST
Max working pressure (bar)	0,5 ÷ 10
Flow rate at 6 bar with $\Delta p=1$ (NI/min)	285
Flow rate at 6 bar with free exhaust (NI/min)	450
Temperature °C	-5 ÷ +50
Weight (g)	26

90° blocking valve

Coding: 551.231.T.A.B.XX

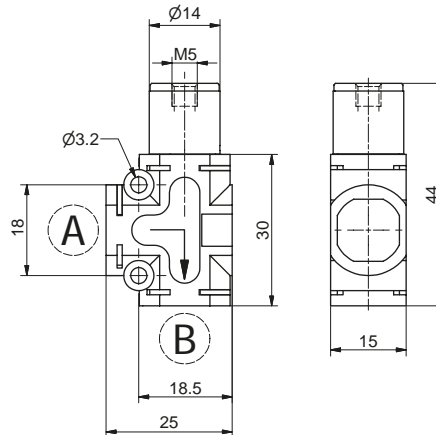

	TYPE
<b>T</b>	1 = Unidirectional 2 = Bidirectional
<b>A</b>	CONNECTION A SEE CONNECTIONS LIST
<b>B</b>	CONNECTION B SEE CONNECTIONS LIST
	CONNECTIONS LIST
	00 = None
	D4 = Straight Ø4
	D6 = Straight Ø6
	D8 = Straight Ø8
	L1 = Female banjo G1/8"
	G4 = Rotating banjo Ø 4
	G6 = Rotating banjo Ø 6
	G8 = Rotating banjo Ø 8
	M1 = G1/8" male
	M2 = G1/4" male
	F1 = G1/8" female

AIR DISTRIBUTION

Example: 551.231.D6.M1.XX

90° blocking valve. Connections "A" Male G1/8 and "B" Tube Ø6

NOTE : For the dimension including cartridges see page Accessories - Function fittings

Piloting curves

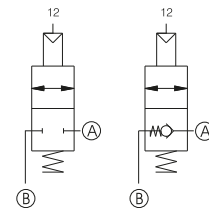
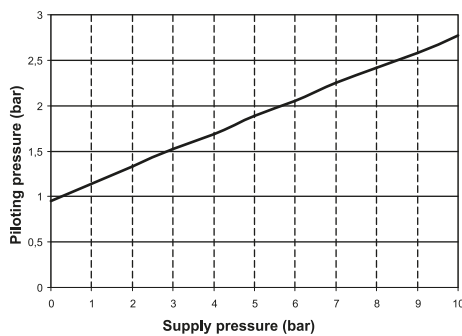

Construction characteristics

- The blocking valve function is to maintain the circuit downstream pressure in the event of loss of supply pressure. It is normally fitted directly onto the cylinder connections ports in order to ensure that, in case of accidental loss of the supply pressure, the units positions is maintained. This is achieved as the blocking valve preserves the pressure inside the pressurised chamber.
- Unidirectional and bidirectional version are both available.
- In the unidirectional version the air flow is free in one direction while in order to allow the flow in the opposite direction is necessary to send a pneumatic signal to the unit connection 12.
- The bidirectional version requires a pneumatic signal on connection 12 to allow the flow in any of the two directions.
- on DIN rail using the relevant adaptor kit (see accessories)
- With 90° bracket (see accessories)
- directly on the support plate thanks to two through holes on the body

Technical characteristics

Fluid	Filtered air. No lubrication needed, if applied it shall be continuous
Working ports size	See CONNECTIONS LIST
Max working pressure (bar)	0,5 ÷ 10
Flow rate at 6 bar with $\Delta p=1$ (NI/min)	285
Flow rate at 6 bar with free exhaust (NI/min)	450
Temperature °C	-5 ÷ +50
Weight (g)	26

**Circuit selector valve - OR**

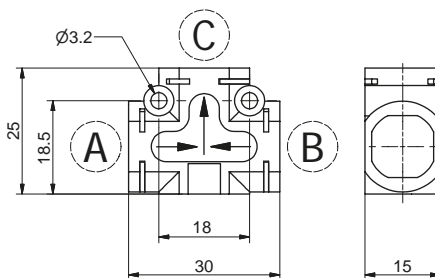

Coding: 551.141.A.B.C

<b>A</b>	CONNECTION A <b>SEE CONNECTIONS LIST</b>
<b>B</b>	CONNECTION B <b>SEE CONNECTIONS LIST</b>
<b>C</b>	CONNECTION C <b>SEE CONNECTIONS LIST</b>
<b>CONNECTIONS LIST</b>	
00 = None	
D4 = Straight Ø4	
D6 = Straight Ø6	
D8 = Straight Ø8	
L1 = Female banjo G1/8"	
G4 = Rotating banjo Ø4	
G6 = Rotating banjo Ø6	
G8 = Rotating banjo Ø8	
M1 = G1/8" male	
M2 = G1/4" male	
F1 = G1/8" female	

Example: 551.141.D8.D8.D8

Circuit selector valve - OR. Connections "A", "B" and "C" Tube Ø8

NOTE : For the dimension including cartridges see page Accessories - Function fittings

**Construction characteristics**

- These valves have two inlets and one output connection and are normally called high pressure selector valves as, when receiving two separate pressure supply, only allow the passage of the highest pressure. The most common application is to operate a component from two separate positions.
- on DIN rail using the relevant adaptor kit (see accessories)
- With 90° bracket (see accessories)
- directly on the support plate thanks to two through holes on the body

Technical characteristics	
Fluid	Filtered air. No lubrication needed, if applied it shall be continuous
Working ports size	See CONNECTIONS LIST
Max working pressure (bar)	10
Flow rate at 6 bar with Δp=1 (Nl/min)	600
Temperature °C	-5 ÷ +50
Weight (g)	10

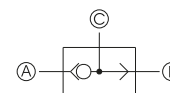

**Circuit selector valve - AND**

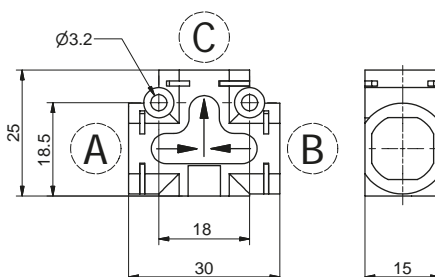

Coding: 551.151.A.B.C

<b>A</b>	CONNECTION A <b>SEE CONNECTIONS LIST</b>
<b>B</b>	CONNECTION B <b>SEE CONNECTIONS LIST</b>
<b>C</b>	CONNECTION C <b>SEE CONNECTIONS LIST</b>
<b>CONNECTIONS LIST</b>	
00 = None	
D4 = Straight Ø4	
D6 = Straight Ø6	
D8 = Straight Ø8	
L1 = Female banjo G1/8"	
G4 = Rotating banjo Ø4	
G6 = Rotating banjo Ø6	
G8 = Rotating banjo Ø8	
M1 = G1/8" male	
M2 = G1/4" male	
F1 = G1/8" female	

Example: 551.151.D6.D6.D6

Circuit selector valve AND. Connections "A", "B" and "C" Tube Ø6

NOTE : For the dimension including cartridges see page Accessories - Function fittings

**Construction characteristics**

- These valves have two inlets and one output connection and are normally called low pressure selector valves as, when receiving two separate pressure supply, only allow the passage of the lowest pressure. The most common application is to operate a component from two separate positions.
- on DIN rail using the relevant adaptor kit (see accessories)
- With 90° bracket (see accessories)
- directly on the support plate thanks to two through holes on the body

Technical characteristics	
Fluid	Filtered air. No lubrication needed, if applied it shall be continuous
Working ports size	See CONNECTIONS LIST
Max working pressure (bar)	10
Flow rate at 6 bar with Δp=1 (Nl/min)	550
Temperature °C	-5 ÷ +50
Weight (g)	10

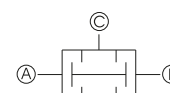

Quick exhaust valve

Coding: 551.161.A.B.XX

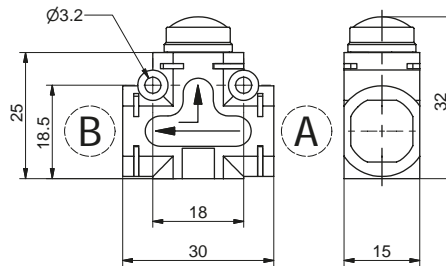

<b>A</b>	CONNECTION A SEE CONNECTIONS LIST
<b>B</b>	CONNECTION B SEE CONNECTIONS LIST
CONNECTIONS LIST	
00 = None	
D4 = Straight Ø4	
D6 = Straight Ø6	
D8 = Straight Ø8	
L1 = Female banjo G1/8"	
G4 = Rotating banjo Ø4	
G6 = Rotating banjo Ø6	
G8 = Rotating banjo Ø8	
M1 = G1/8" male	
M2 = G1/4" male	
F1 = G1/8" female	

Example: 551.161.D8.D8.XX

Quick exhaust valve. Connections "A" and "B" Tube Ø6

NOTE : For the dimension including cartridges see page Accessories - Function fittings

Construction characteristics

- These are 3 ways, two positions valves which can be directly mounted onto the actuator or between the actuator and the control valve. Their function is to discharge the air directly into the atmosphere without going through the pneumatic circuit enabling the actuator to reach the maximum speed.
- on DIN rail using the relevant adaptor kit (see accessories)
- With 90° bracket (see accessories)
- directly on the support plate thanks to two through holes on the body

Technical characteristics	
Fluid	Filtered air. No lubrication needed, if applied it shall be continuous
Working ports size	See CONNECTIONS LIST
Max working pressure (bar)	10
Flow rate at 6 bar with $\Delta p=1$ (Nl/min)	250
Flow rate at 6 bar with free exhaust (Nl/min)	500
Temperature °C	-5 ÷ +50
Weight (g)	15

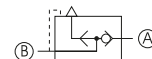

Pressure indicator

Coding: 551.178.A.B.XX

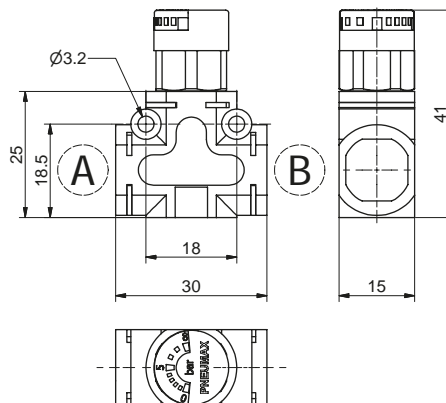

<b>A</b>	CONNECTION A SEE CONNECTIONS LIST
<b>B</b>	CONNECTION B SEE CONNECTIONS LIST
CONNECTIONS LIST	
00 = None	
D4 = Straight Ø4	
D6 = Straight Ø6	
D8 = Straight Ø8	
L1 = Female banjo G1/8"	
G4 = Rotating banjo Ø4	
G6 = Rotating banjo Ø6	
G8 = Rotating banjo Ø8	
M1 = G1/8" male	
M2 = G1/4" male	
F1 = G1/8" female	

Example: 551.178.D6.D4.XX

Pressure indicator. Connections "A" Tube Ø6, "B" Tube Ø4

NOTE : For the dimension including cartridges see page Accessories - Function fittings

Construction characteristics

- The pressure visual indicator is a device which measures the pressure inside a pneumatic circuit. The 0 to 8 bar visual indicator makes very easy to monitor the pressure state inside the circuit. It can be use on its own or can be coupled with another device.
- It can be use on its own or can be coupled with another device.
- on DIN rail using the relevant adaptor kit (see accessories)
- With 90° bracket (see accessories)
- directly on the support plate thanks to two through holes on the body

Technical characteristics	
Fluid	Filtered air. No lubrication needed, if applied it shall be continuous
Working ports size	See CONNECTIONS LIST
Max working pressure (bar)	8
Visualization scale (bar)	0 ÷ 8
Temperature °C	-5 ÷ +50
Weight (g)	20.5

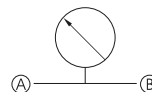

**In line progressive start-up valve**

Coding: 551.181.A.B.XX

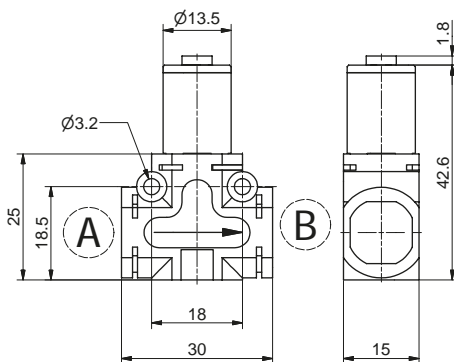

<b>A</b>	CONNECTION A SEE CONNECTIONS LIST
<b>B</b>	CONNECTION B SEE CONNECTIONS LIST
CONNECTIONS LIST	
00 = None	
D4 = Straight Ø4	
D6 = Straight Ø6	
D8 = Straight Ø8	
L1 = Female banjo G1/8"	
G4 = Rotating banjo Ø4	
G6 = Rotating banjo Ø6	
G8 = Rotating banjo Ø8	
M1 = G1/8" male	
M2 = G1/4" male	
F1 = G1/8" female	

Example: 551.181.D6.D4.XX

In line progressive start-up valve. Connections "A" Tube Ø6, "B" Tube Ø4

NOTE : For the dimension including cartridges see page Accessories - Function fittings

**Construction characteristics**

- The soft start valve is a device designed to gradually pressurise the downstream circuit until 50% of the upstream pressure value is reached.
- Once the 50% of the upstream pressure value is reached in the down stream circuit the valve fully opens allowing full air passage.
- The filling time can be adjusted thanks to the built in flow regulator.
- This device is used in order to ensure that during the pneumatic circuit start up the cylinders will return to their home position slowly avoiding collisions or sudden movements.

Technical characteristics	
Fluid	Filtered air. No lubrication needed, if applied it shall be continuous
Working ports size	See CONNECTIONS LIST
Opening pressure (Pa)	50% of the inlet pressure (Pi)
Flow rate at 6 bar with free exhaust (Nl/min) from 1 to 2 with opening circuit	350
Flow rate at 6 bar with $\Delta p=1$ from 1 to 2 with opening circuit	600
Flow rate at 6 bar with $\Delta p=1$ from 2 to 1 with opening pin	650
Temperature °C	-5 ÷ +50
Weight (g)	31

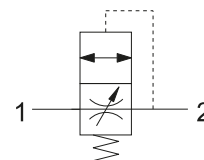

**90° progressive start-up valve**

Coding: 551.281.A.B.XX

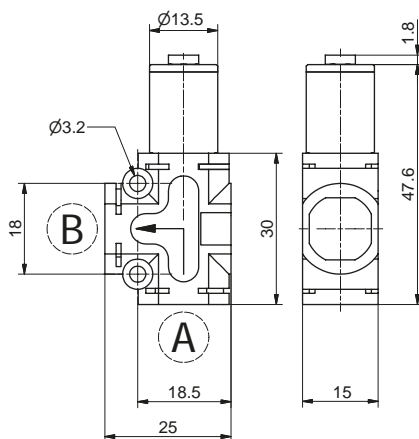

<b>A</b>	CONNECTION A SEE CONNECTIONS LIST
<b>B</b>	CONNECTION B SEE CONNECTIONS LIST
CONNECTIONS LIST	
00 = None	
D4 = Straight Ø4	
D6 = Straight Ø6	
D8 = Straight Ø8	
L1 = Female banjo G1/8"	
G4 = Rotating banjo Ø4	
G6 = Rotating banjo Ø6	
G8 = Rotating banjo Ø8	
M1 = G1/8" male	
M2 = G1/4" male	
F1 = G1/8" female	

Example: 551.281.M1.D4.XX

90° progressive start-up valve. connections "A" Male G1/8", "B" Tube Ø4

NOTE : For the dimension including cartridges see page Accessories - Function fittings

**Construction characteristics**

- The soft start valve is a device designed to gradually pressurise the downstream circuit until 50% of the upstream pressure value is reached.
- Once the 50% of the upstream pressure value is reached in the down stream circuit the valve fully opens allowing full air passage.
- The filling time can be adjusted thanks to the built in flow regulator.
- This device is used in order to ensure that during the pneumatic circuit start up the cylinders will return to their home position slowly avoiding collisions or sudden movements.

Technical characteristics	
Fluid	Filtered air. No lubrication needed, if applied it shall be continuous
Working ports size	See CONNECTIONS LIST
Opening pressure (Pa)	50% of the inlet pressure (Pi)
Flow rate at 6 bar with free exhaust (Nl/min) from 1 to 2 with opening circuit	350
Flow rate at 6 bar with $\Delta p=1$ from 1 to 2 with opening circuit	600
Flow rate at 6 bar with $\Delta p=1$ from 2 to 1 with opening pin	650
Temperature °C	-5 ÷ +50
Weight (g)	31

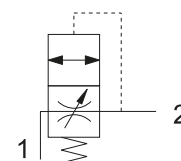

**In line blocking valve with flow control valve**

Coding: 551.1F<sup>T</sup>.<sup>A</sup>.<sup>B</sup>.XX

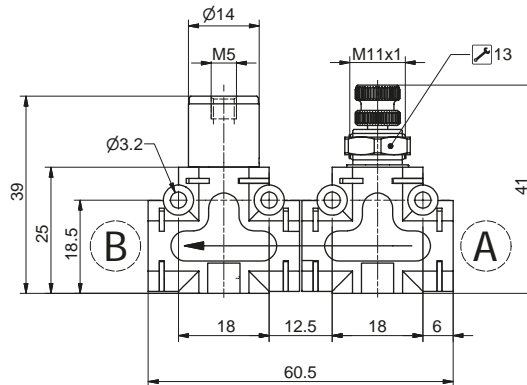
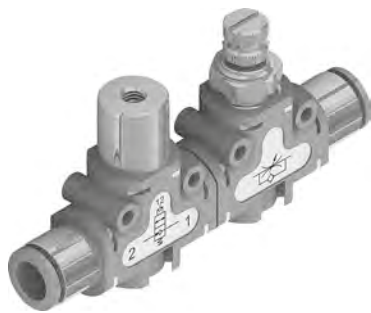

<b>TYPE</b>
<b>1</b> = Unidirectional blocking valve + Unidirectional flow control valve
<b>2</b> = Bidirectional blocking valve + Bidirectional flow control valve
<b>T</b>
<b>3</b> = Unidirectional blocking valve + Bidirectional flow control valve
<b>4</b> = Bidirectional blocking valve + Unidirectional flow control valve
<b>A</b>
<b>CONNECTION A</b>
<b>SEE CONNECTIONS LIST</b>
<b>CONNECTION B</b>
<b>B</b>
<b>SEE CONNECTIONS LIST</b>
<b>CONNECTIONS LIST</b>
<b>00</b> = None
<b>D4</b> = Straight Ø4
<b>D6</b> = Straight Ø6
<b>D8</b> = Straight Ø8
<b>L1</b> = Female banjo G1/8"
<b>G4</b> = Rotating banjo Ø 4
<b>G6</b> = Rotating banjo Ø 6
<b>G8</b> = Rotating banjo Ø 8
<b>M1</b> = G1/8" male
<b>M2</b> = G1/4" male
<b>F1</b> = G1/8" female

1  
AIR DISTRIBUTION

Example: 551.1F1.00.00.XX

In line blocking valve + flow control valve. Without connections "A" and "B"

NOTE: For the dimension including cartridges see page Accessories - Function fittings

**Piloting curves**

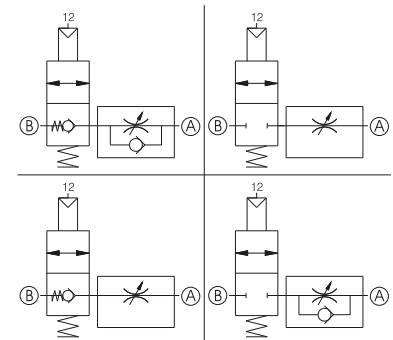
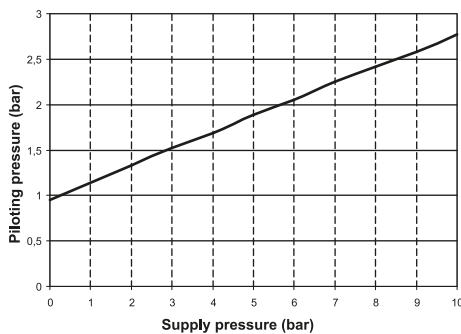

**Construction characteristics**

- The combination of this two functions ensures that the downstream pressure is maintained in case of accidental loss of supply pressure and at the same time grants the possibility to regulate the circuit flow rate. A typical application of this combination is close to or directly assembled onto the actuator connection ports. This allows to keep pressurised the cylinder chamber in case of accidental loss of supply pressure and to regulate the exhaust flow rate when the blocking valve is actuated.
- The possible combinations are the following:
  - Unidirectional blocking valve + unidirectional flow control valve
  - Bidirectional blocking valve + bidirectional flow control valve
  - Bidirectional blocking valve + unidirectional flow control valve
  - Unidirectional blocking valve + bidirectional flow control valve

**Technical characteristics**

Fluid	Filtered air. No lubrication needed, if applied it shall be continuous
Working ports size	See CONNECTIONS LIST
Max working pressure (bar)	0,5 ÷ 10
Flow rate at 6 bar with Δp=1 (NI/min)	285
Orifice size (mm)	Ø3
Temperature °C	-5 ÷ +50
Weight (g)	62

► 90° blocking valve + flow control valve

Coding: 551.2F<sup>T</sup>.A.B.XX

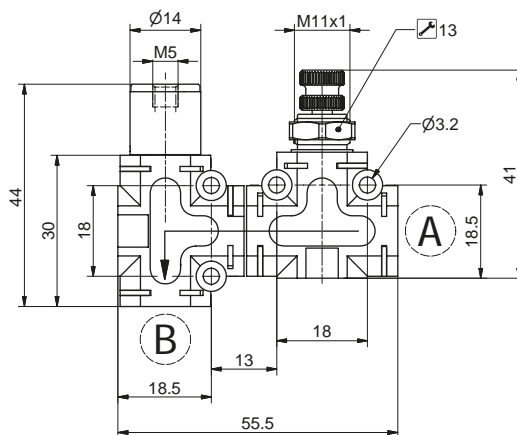

TYPE	1 = 90° Unidirectional blocking valve + Unidirectional flow control valve 2 = 90° Bidirectional blocking valve + Bidirectional flow control valve 3 = 90° Unidirectional blocking valve + Bidirectional flow control valve 4 = 90° Bidirectional blocking valve + Unidirectional flow control valve
<b>T</b>	CONNECTION A <b>SEE CONNECTIONS LIST</b> CONNECTION B <b>SEE CONNECTIONS LIST</b>
<b>A</b>	CONNECTIONS LIST
<b>B</b>	CONNECTIONS LIST
	00 = None D4 = Straight Ø4 D6 = Straight Ø6 D8 = Straight Ø8 L1 = Female banjo G1/8" G4 = Rotating banjo Ø 4 G6 = Rotating banjo Ø 6 G8 = Rotating banjo Ø 8 M1 = G1/8" male M2 = G1/4" male F1 = G1/8" female

1  
AIR DISTRIBUTION

Example: 5512F1.00.00.XX  
90° blocking valve + flow control valve. Without connections "A" and "B"  
NOTE : For the dimension including cartridges see page Accessories - Function fittings

Piloting curves

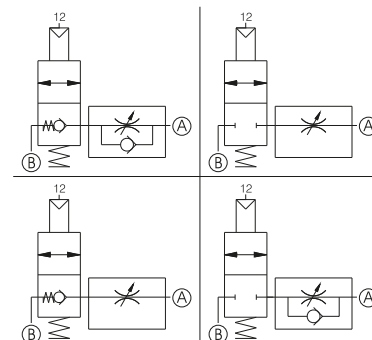
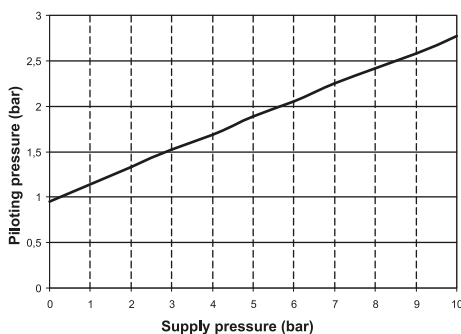

Construction characteristics

- The combination of this two functions ensures that the downstream pressure is maintained in case of accidental loss of supply pressure and at the same time grants the possibility to regulate the circuit flow rate. A typical application of this combination is close to or directly assembled onto the actuator connection ports. This allows to keep pressurised the cylinder chamber in case of accidental loss of supply pressure and to regulate the exhaust flow rate when the blocking valve is actuated.
- The possible combinations are the following:
  - 90° Unidirectional blocking valve + Unidirectional flow control valve
  - 90° Bidirectional blocking valve + Bidirectional flow control valve
  - 90° Bidirectional blocking valve + Unidirectional flow control valve
  - 90° Unidirectional blocking valve + Bidirectional flow control valve

Technical characteristics

Fluid	Filtered air. No lubrication needed, if applied it shall be continuous
Working ports size	See CONNECTIONS LIST
Max working pressure (bar)	0,5 + 10
Flow rate at 6 bar with Δp=1 (Nl/min)	285
Orifice size (mm)	Ø3
Temperature °C	-5 ÷ +50
Weight (g)	62

In line blocking valve + quick exhaust valve

Coding: 551.1G<sup>T</sup>.A.B.XX

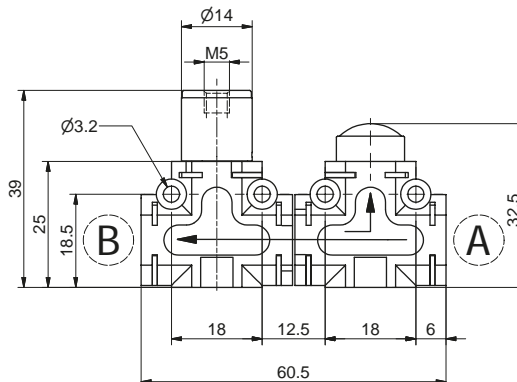

	TYPE
<b>1</b>	Unidirectional blocking valve + quick exhaust valve
<b>2</b>	Bidirectional blocking valve + quick exhaust valve
<b>A</b>	CONNECTION A SEE CONNECTIONS LIST
<b>B</b>	CONNECTION B SEE CONNECTIONS LIST
	CONNECTIONS LIST
	00 = None
	D4 = Straight Ø4
	D6 = Straight Ø6
	D8 = Straight Ø8
	L1 = Female banjo G1/8"
	G4 = Rotating banjo Ø 4
	G6 = Rotating banjo Ø 6
	G8 = Rotating banjo Ø 8
	M1 = G1/8" male
	M2 = G1/4" male
	F1 = G1/8" female

1  
AIR DISTRIBUTION

Example: 5511G1.00.00.XX

In line blocking valve + quick exhaust valve. Without connections "A" and "B"

NOTE: For the dimension including cartridges see page Accessories - Function fittings

Piloting curves

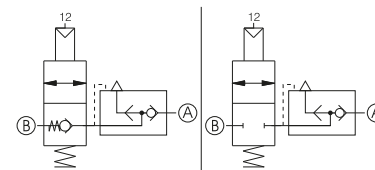
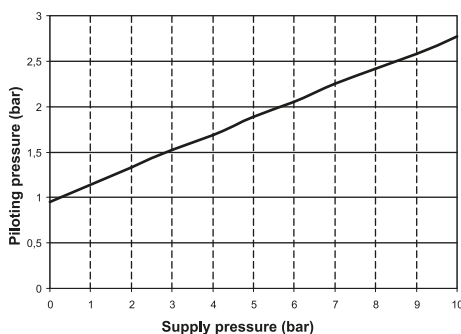

Construction characteristics

- The combination of this two functions ensures that the downstream pressure is maintained in case of accidental loss of supply pressure and at the same time allows for the air to be directly discharged into the atmosphere without going through the pneumatic circuit. A typical application of this combination is close to or directly assembled onto the actuator connection ports. This allows to keep pressurised the cylinder chamber in case of accidental loss of supply pressure and to quickly discharge the same chamber when the blocking valve is actuated.
- The possible combinations are the following:
  - Unidirectional blocking valve + quick exhaust valve
  - Bidirectional blocking valve + quick exhaust valve

Technical characteristics

Fluid	Filtered air. No lubrication needed, if applied it shall be continuous
Working ports size	See CONNECTIONS LIST
Max working pressure (bar)	0.5 ÷ 10
Flow rate at 6 bar with Δp=1 (NI/min)	285
Temperature °C	-5 ÷ +50
Weight (g)	51



► 90° blocking valve + quick exhaust valve

Coding: 551.2G<sup>T</sup>.A.B.XX

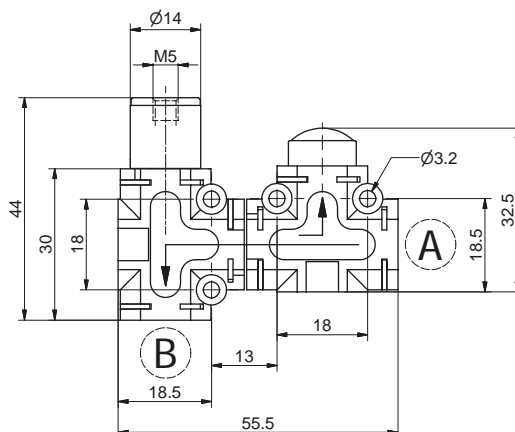

	TYPE
1	= 90° Unidirectional blocking valve + quick exhaust valve
2	= 90° Bidirectional blocking valve + quick exhaust valve
A	CONNECTION A SEE CONNECTIONS LIST
B	CONNECTION B SEE CONNECTIONS LIST
	CONNECTIONS LIST
	00 = None
	D4 = Straight Ø4
	D6 = Straight Ø6
	D8 = Straight Ø8
	L1 = Female banjo G1/8"
	G4 = Rotating banjo Ø 4
	G6 = Rotating banjo Ø 6
	G8 = Rotating banjo Ø 8
	M1 = G1/8" male
	M2 = G1/4" male
	F1 = G1/8" female

1 AIR DISTRIBUTION

Example: 551.2G1.00.00.XX  
90° bidirectional blocking valve + quick exhaust valve. Without connections "A" and "B"  
NOTE : For the dimension including cartridges see page Accessories - Function fittings

Piloting curves

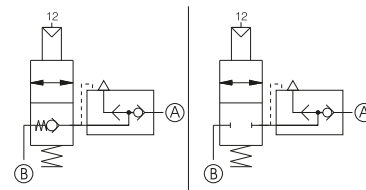
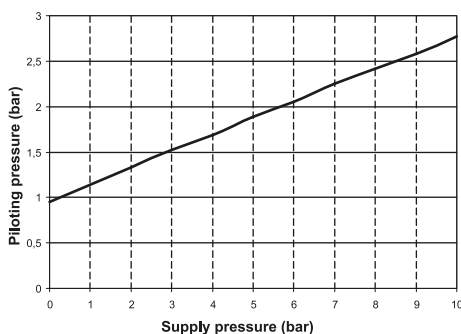

Construction characteristics

- The combination of this two functions ensures that the downstream pressure is maintained in case of accidental loss of supply pressure and at the same time allows for the air to be directly discharged into the atmosphere without going through the pneumatic circuit. A typical application of this combination is close to or directly assembled onto the actuator connection ports. This allows to keep pressurised the cylinder chamber in case of accidental loss of supply pressure and to quickly discharge the same chamber when the blocking valve is actuated.
- The possible combinations are the following:
  - 90° Unidirectional blocking valve + quick exhaust valve
  - 90° Bidirectional blocking valve + quick exhaust valve

Technical characteristics	
Fluid	Filtered air. No lubrication needed, if applied it shall be continuous
Working ports size	See CONNECTIONS LIST
Max working pressure (bar)	0,5 ÷ 10
Flow rate at 6 bar with Δp=1 (NI/min)	285
Temperature °C	-5 ÷ +50
Weight (g)	51

**In line pressure regulator + pressure indicator**

Coding: 551.1H**T**.**A**.**B**.XX

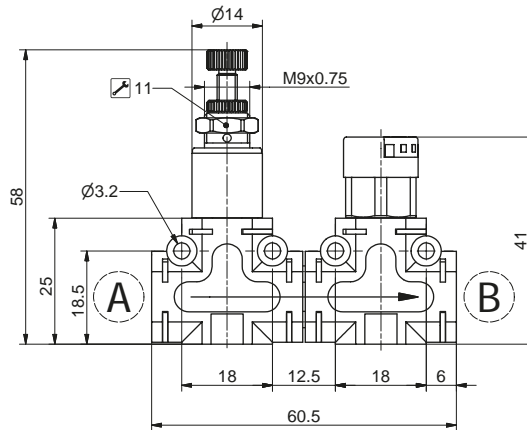

TYPE	
<b>T</b>	2 = 0-2 bar
	4 = 0-4 bar
	8 = 0-8 bar
CONNECTION A	
<b>A</b>	SEE CONNECTIONS LIST
CONNECTION B	
<b>B</b>	SEE CONNECTIONS LIST
CONNECTIONS LIST	
<b>00</b>	= None
<b>D4</b>	= Straight Ø4
<b>D6</b>	= Straight Ø6
<b>D8</b>	= Straight Ø8
<b>L1</b>	= Female banjo G1/8"
<b>G4</b>	= Rotating banjo Ø 4
<b>G6</b>	= Rotating banjo Ø 6
<b>G8</b>	= Rotating banjo Ø 8
<b>M1</b>	= G1/8" male
<b>M2</b>	= G1/4" male
<b>F1</b>	= G1/8" female

Example: 551.1H2.M1.D4.XX

In line pressure regulator, adjusting range 0 - 2 bar + pressure indicator. Connections "A" Male G 1/8 and "B" Tube Ø4

NOTE : For the dimension including cartridges see page Accessories - Function fittings

**Construction characteristics**

- The combination of this two functions ensures the possibility to regulate the downstream pressure while directly visualising the adjusted pressure value.
- The possible combinations are the following:
  - 0 to 2 bar pressure regulator + pressure visual indicator
  - 0 to 4 bar pressure regulator + pressure visual indicator
  - 0 to 8 bar pressure regulator + pressure visual indicator
- The visual indicator Pressure range (bar) is always 0 to 8 bar

Technical characteristics	
Fluid	Filtered air. No lubrication needed, if applied it shall be continuous
Working ports size	See CONNECTIONS LIST
Max working pressure (bar)	8
Visualization scale (bar)	0 ÷ 8
Pressure range (bar)	0 ÷ 2 0 ÷ 4 0 ÷ 8
Temperature °C	-5 ÷ +50
Weight (g)	62

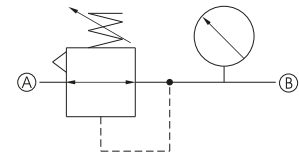

**90° pressure regulator + pressure indicator**

Coding: 551.2H**T**.**A**.**B**.XX

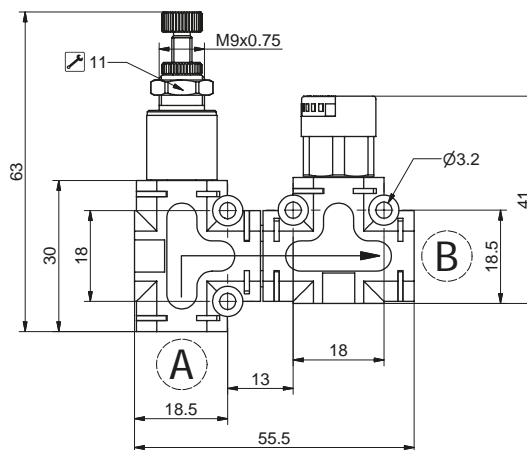

TYPE	
<b>T</b>	2 = 0-2 bar
	4 = 0-4 bar
	8 = 0-8 bar
CONNECTION A	
<b>A</b>	SEE CONNECTIONS LIST
CONNECTION B	
<b>B</b>	SEE CONNECTIONS LIST
CONNECTIONS LIST	
<b>00</b>	= None
<b>D4</b>	= Straight Ø4
<b>D6</b>	= Straight Ø6
<b>D8</b>	= Straight Ø8
<b>L1</b>	= Female banjo G1/8"
<b>G4</b>	= Rotating banjo Ø 4
<b>G6</b>	= Rotating banjo Ø 6
<b>G8</b>	= Rotating banjo Ø 8
<b>M1</b>	= G1/8" male
<b>M2</b>	= G1/4" male
<b>F1</b>	= G1/8" female

Example: 551.2H2.M1.D4.XX

90° pressure regulator, adjusting range 0 - 2 bar + pressure indicator. Connections "A" Male G 1/8 and "B" Tube Ø4

NOTE : For the dimension including cartridges see page Accessories - Function fittings

**Construction characteristics**

- The combination of this two functions ensures the possibility to regulate the downstream pressure while directly visualising the adjusted pressure value.
- The possible combinations are the following:
  - 0 to 2 bar pressure regulator + pressure visual indicator
  - 0 to 4 bar pressure regulator + pressure visual indicator
  - 0 to 8 bar pressure regulator + pressure visual indicator
- The visual indicator Pressure range (bar) is always 0 to 8 bar

Technical characteristics	
Fluid	Filtered air. No lubrication needed, if applied it shall be continuous
Working ports size	See CONNECTIONS LIST
Max working pressure (bar)	8
Visualization scale (bar)	0 ÷ 8
Pressure range (bar)	0 ÷ 2 0 ÷ 4 0 ÷ 8
Temperature °C	-5 ÷ +50
Weight (g)	62

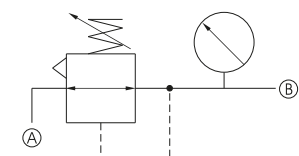

AIR DISTRIBUTION

**Coupling kit (pins and forks)**

Coding: 55160

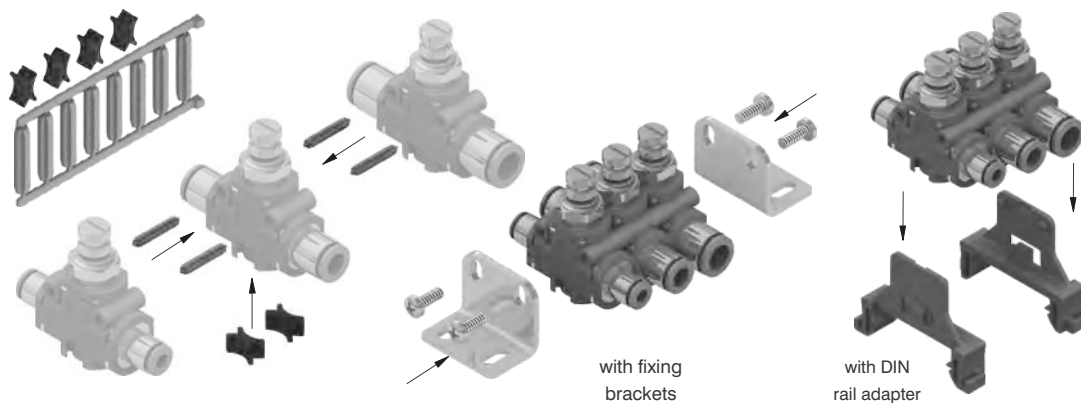

- Weight 2,5 g
- The kit, which includes a series of pins and forks, enables to join together in a fast and safe way the function fittings. The pins, once inserted in the front holes, ensure resistance against forces applied perpendicularly and sideways (for example the insertion of the tube in the cartridges).
- The forks, once located in the profiled housing ensures that the parts are held together tightly.
- The kit allows for 5 function fittings to be mounted together.

**Fixing brackets**

**DIN rail adapter**

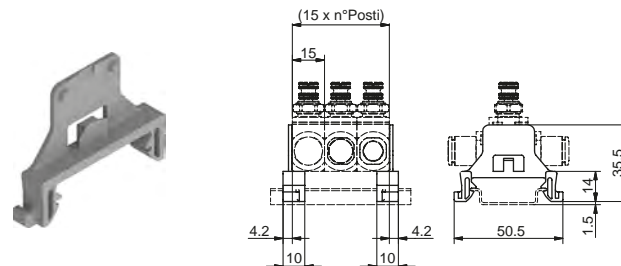
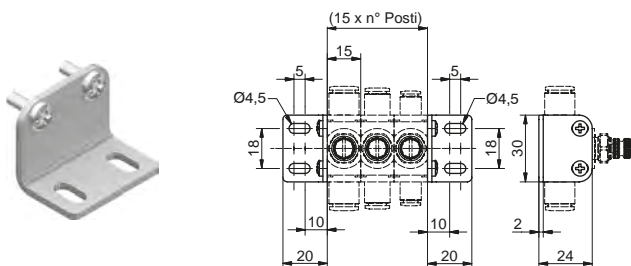

Coding: 55150

Weight 18 g  
The kit comprises two fixing brackets and the screws

Coding: 55116

Weight 4 g  
The kit comprises two adapters

**Ø4, Ø6 & Ø8 straight cartridge**

Coding: 551KD<sup>Ⓢ</sup>

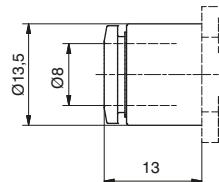
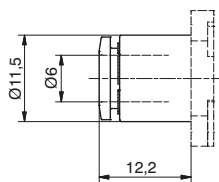
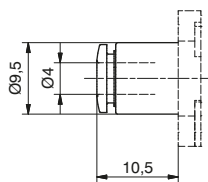

Weight 7,5 g

551KD4

Weight 7,3 g

551KD6

Weight 7 g

551KD8

CONNECTIONS	
4	= tube Ø4
6	= tube Ø6
8	= tube Ø8



AIR DISTRIBUTION

► Ø4, Ø6 & Ø8 banjo PL cartridge

Coding: 551KG<sup>Ⓢ</sup>

CONNECTIONS	
Ⓢ	4 = tube Ø4
	6 = tube Ø6
	8 = tube Ø8

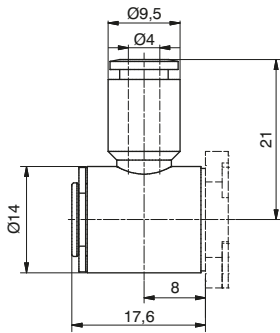

Weight 13,6 g

551KG4

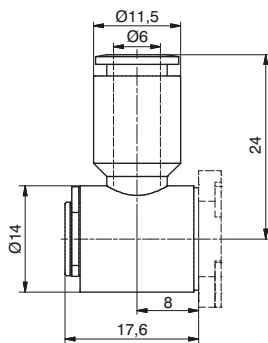

Weight 14 g

551KG6

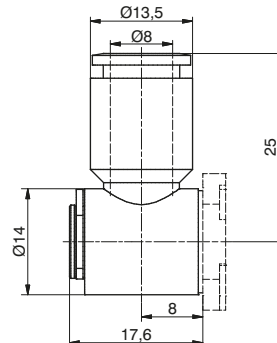

Weight 14,3 g

551KG8

► G1/8" banjo artridge

Coding: 551KL<sup>Ⓢ</sup>

CONNECTIONS	
Ⓢ	1 = G1/8"

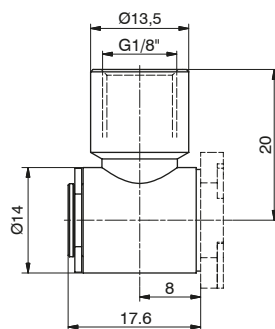

Weight 30 g

551KL1

► Connection for multiple function



Coding: 551KUU Weight 14 g

► Cartridge

Coding: 551K<sup>Ⓢ</sup>

CONNECTIONS	
Ⓢ	M1 = G1/8" male straight cartridge
	M2 = G1/4" male straight cartridge
	F1 = G1/8" female straight cartridge

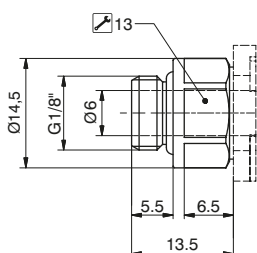

Weight 14 g  
G1/8" male straight cartridge

551KM1

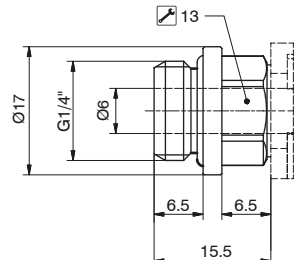

Weight 20 g  
G1/4" male straight cartridge

551KM2

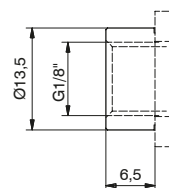

Weight 9 g  
G1/8" female straight cartridge

551KF1

## Series 1750-1760

### General

This new type of miniaturised pressure regulators are mostly indicated for the use on the secondary level of the pneumatic circuits. Thanks to the contained dimensions are particularly indicated to be used very closely or directly mounted onto the consumption. Three versions are available.

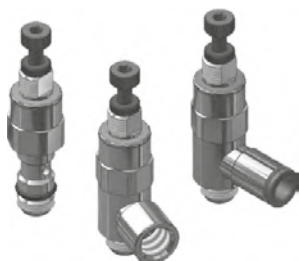

Version rod G1/8" swivel ring with female thread G 1/8" and G 1/4" or push-in fitting for tube Ø4, Ø6 and Ø8

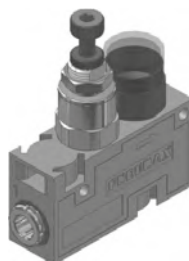

model with body in technopolymer integrated gauge and quick coupling fittings for tube Ø4 and Ø6.

#### G1/8" model to be directly mounted onto the valve

Compact design to be directly mounted onto the valves uses standard swivel rings with G1/8" female thread (ref 41218) or quick coupling fittings for tube sizes. It is also possible to supply the regulating shaft without the swivel ring.

#### Model with body in technopolymer and integrated gauge

is the more complete solution, comprises a movable gauge which enables to check the regulated pressure.

Is manufactured using the same regulating unit as the base model fitted into a technopolymer body on which are inserted two quick coupling cartridges, 4mm or 6mm tube for inlet and outlet connections; two side plates lock the cartridges and gauge in position.

It is possible to join together more than one regulator by means of a dedicated adaptor made of technopolymer which must be inserted in the appropriate slot. ( the air must be supplied independently to each regulator.)

Several mounting solutions are available: wall mounting via two mounting holes, on DIN rail using the specific accessories or on panels.

### Mounting solutions

G1/8" model to be directly mounted onto the valve:  
Directly mounted onto the valves threaded connections (consumptions)

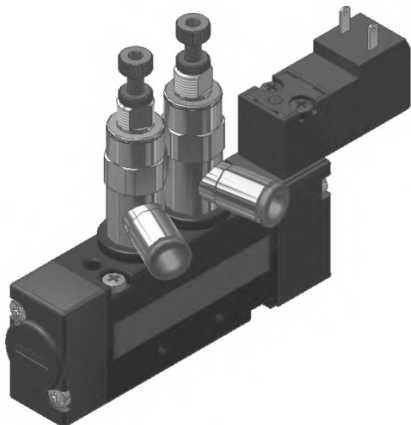

Model with body in technopolymer and integrated gauge:  
Panel mounting via the locking nut

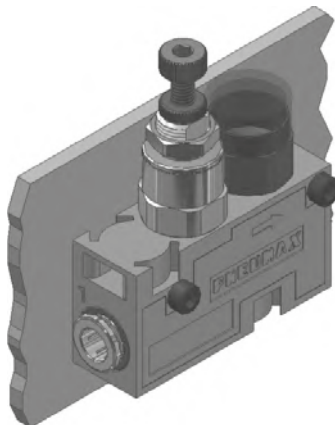

Model with body in technopolymer and integrated gauge:  
Wall mounting via the mounting holes on the body

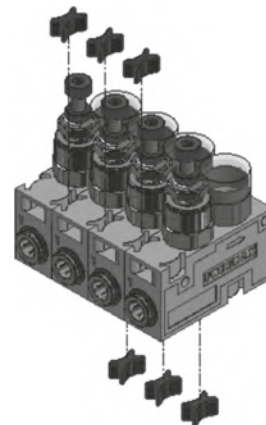

Model with body in technopolymer and integrated gauge:  
On DIN rail using the specific accessories

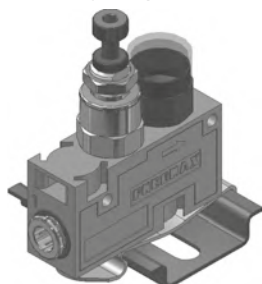

Model with body in technopolymer and integrated gauge:  
Panel mounting via the locking nut

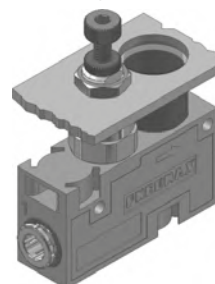

**Miniaturised pressure regulators - with technopolymer body**

Coding: 17522A<sup>C</sup><sup>G</sup>

**Construction characteristics**

- Regulating cartridge = Nickel-plated brass
- Regulator body = Technopolymer
- Seals = Oil resistant nitrilic rubber (NBR)
- Plunger spring = AISI 302
- Regulating spring = Spring suitable steel
- Plunger = Oil resistant nitrilic rubber (NBR)
- Other parts = Brass

Operational characteristics	
Max working pressure (bar)	10
Temperature °C	-5 ÷ +50
Flow rate at 6 bar with Δp=1 (NI/min)	120
Working ports size	Ø4-Ø6
Inlet connections sizes	Ø4-Ø6
Mounting positioning	Any

CONNECTIONS	
<sup>C</sup>	4 = Tube Ø4 6 = Tube Ø6
REGULATION RANGE	
<sup>G</sup>	C = 0÷8bar B = 0÷4bar A = 0÷2bar

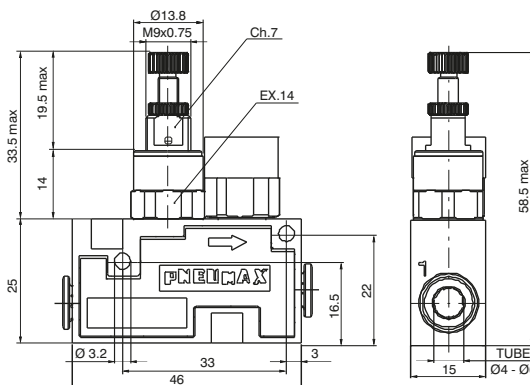

**Miniaturised pressure regulators, rod G1/8"**

Coding: 17602A<sup>A</sup><sup>G</sup>

**Construction characteristics**

- Regulating cartridge = Nickel-plated brass
- Regulator body = Nickel-plated brass
- Seals = Oil resistant nitrilic rubber (NBR)
- Plunger spring = AISI 302
- Regulating spring = Spring suitable steel
- Plunger = Oil resistant nitrilic rubber (NBR)
- Other parts = Brass

Operational characteristics	
Max working pressure (bar)	10
Temperature °C	-5 ÷ +50
Flow rate at 6 bar with Δp=1 (NI/min)	120
Working ports size	G1/8"
Inlet connections sizes	G1/8"-Ø4-Ø6-Ø8
Mounting positioning	Any

SWIVEL RING	
<sup>A</sup>	0 = None 1 = Swivel ring G1/8" female 4 = Tube Ø4 6 = Tube Ø6 8 = Tube Ø8
REGULATION RANGE	
<sup>G</sup>	C = 0÷8bar B = 0÷4bar A = 0÷2bar

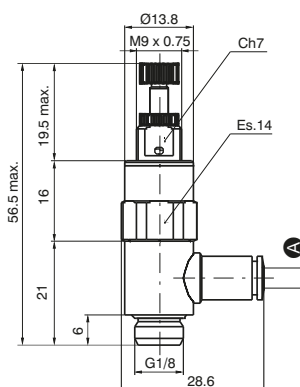

**Miniaturised pressure regulators, rod G1/4"**

Coding: 17602B<sup>A</sup><sup>G</sup>

**Construction characteristics**

- Regulating cartridge = Nickel-plated brass
- Regulator body = Nickel-plated brass
- Seals = Oil resistant nitrilic rubber (NBR)
- Plunger spring = AISI 302
- Regulating spring = Spring suitable steel
- Plunger = Oil resistant nitrilic rubber (NBR)
- Other parts = Brass

Operational characteristics	
Max working pressure (bar)	10
Temperature °C	-5 ÷ +50
Flow rate at 6 bar with Δp=1 (NI/min)	120
Working ports size	G1/4"
Inlet connections sizes	G1/4"-Ø4-Ø6-Ø8
Mounting positioning	Any

SWIVEL RING	
<sup>A</sup>	0 = None 1 = Swivel ring G1/4" female 6 = Tube Ø6 8 = Tube Ø8
REGULATION RANGE	
<sup>G</sup>	C = 0÷8bar B = 0÷4bar A = 0÷2bar

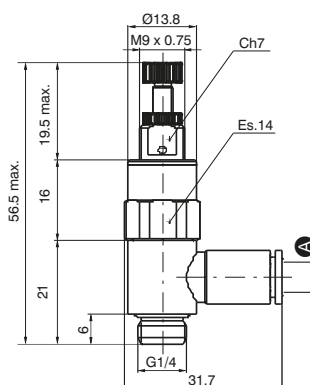



## Series Mini-RAP

### Technical data

Working temperature: -20°C +70°C  
Maximum working pressure: 10 bar  
Fluid: Compressed air (others fluids on requests)  
Nichel-plated brass body, Brass grip, Silicone free NBR gaskets  
Thread: Cylindrical with O-Ring  
Maximum fixing torque for fittings  
Thread: M3: 0,4 Nm  
Thread: M6 and M6x0,75: 1,3 Nm

### Main characteristics

1. Can be inserted and extracted with one hand
2. Suitable for tube Rilsan, Polyurethane, Nylon, Polyethylene
3. Supercompact
4. Extremely lightweight yet sturdy
5. O-Ring provided with his own seat to ensure seal with polished surface
6. Suitable for vacuum applicatio



AIR DISTRIBUTION

RDR Straight male adaptor (parallel)

Coding: RDR3.40-MH05

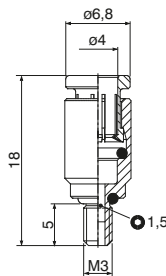

RDR3.40-MH05

RDR Straight male adaptor (parallel)

Coding: RDR6.40-**V**

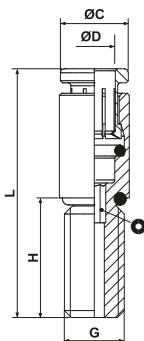

CODE	ØD	G	ØC	H	L	Ø
RDR6.40-MH12	4	M6	6,8	12	25	2
RDR6.40-FH12	4	M6x0,75	6,8	12	25	2

VERSION		
<b>V</b> MH12	=	M6, H=12mm
FH12	=	M6x0,75, H=12mm

RDR6.40-**V**

RGR Complete single banjo with stem

Coding: RGR3.40-MH05

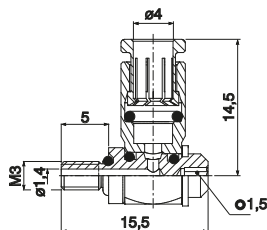

RGR3.40-MH05

RGR Complete single banjo with stem

Coding: RGR6.40-**V**

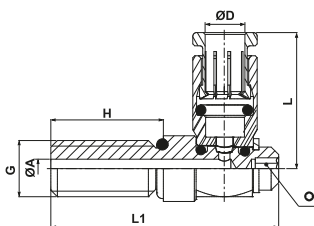

CODE	ØD	G	ØA	H	L1	L	Ø
RGR6.40-MH12	4	M6	2	12	24,3	14,5	2
RGR6.40-FH12	4	M6x0,75	2	12	24,3	14,5	2

VERSION		
<b>V</b> MH12	=	M6, H=12mm
FH12	=	M6x0,75, H=12mm

RGR6.40-**V**





## Series 2700

### General

The 2700 Series of solenoid operated valves have been designed in accordance with ISO 15407, a standard for both pneumatic and electrical layout.  
This series of valves have a 27mm valve body width and a nominal flow rate of 1000 NI/Min.  
The solenoid valves are mounted upon a modular sub-base with G1/4" pneumatic connections and built in electrical connection.  
Another feature of the 2700 series is that it can be equipped with the serial bus modules currently being used with our Optyma-T valve series, thus offering an extremely flexible product that can be integrated with standard communication protocols (CANopen®, PROFIBUS DP, DeviceNet, EtherNet/IP, PROFINET I/O RT/IRT, EtherCAT®, Powerlink and Modbus/TCP).  
In addition to the serial bus modules, the valves manifolds can also be used with either a 25 or 37 pin D-SUB connectors offering control of up to a maximum of 32 electrical signals.

**“Shifting time of pneumatic directional control valves or moving parts, logic devices were measured in accordance to ISO 12238:2001, Pneumatic fluid power-Directional control valves-Measurement of shifting time”**

### Main characteristics

- Integrated and optimized electrical connection system.
- IP65 protection degree.
- Only one 26mm size.
- Monostable and bistable solenoid valves with the same size dimensions.
- G1/4" quick coupling connections.
- Easy and fast manifold assembling.

### Construction characteristics

Body	Aluminium
Operators	Technopolymer
Spacers	HNBR 75-80 Shore A
Spools	Aluminium
Springs	AISI 302 stainless steel
Pistons	Technopolymer
Piston seals	NBR

### Functions

SV 5/2 MONOSTABLE SOLENOID-SPRING  
SV 5/2 MONOSTABLE SOLENOID-DIFFERENTIAL  
SV 5/2 BISTABLE SOLENOID-SOLENOID  
SV 5/3 C.C. SOLENOID-SOLENOID  
SV 2x3/2 N.C.-N.C. (=5/3 O.C.) SOLENOID-SOLENOID  
SV 2x3/2 N.O.-N.O. (=5/3 P.C.) SOLENOID-SOLENOID  
SV 2x3/2 N.C.-N.O. SOLENOID-SOLENOID

### Technical characteristics

Voltage	24 VDC ±10% PNP
Pilot consumption	1 Watt - 2,3Watt
Valve working pressure [1]	from vacuum up to 10 bar
Operating temperature	-5°C +50°C
Life (standard operating conditions)	50000000
Fluid	Filtered air. No lubrication needed, if applied it shall be continuous

1  
AIR DISTRIBUTION



1 AIR DISTRIBUTION

**Solenoid - Spring**

Coding: 2741.52.00.**P.T**

Operational characteristics	
Fluid	Filtered air. No lubrication needed, if applied it shall be continuous
Working pressure (bar)	From vacuum to 10
Minimum piloting pressure (bar)	2
Temperature °C	-5 ÷ +50
Flow rate at 6 bar with Δp=1 (NI/min)	1000
Response time according to ISO 12238, activation time (ms)	20
Response time according to ISO 12238, deactivation time (ms)	38

*Shifting time of pneumatic directional control valves or moving parts, logic devices were measured in accordance to ISO 12238:2001*

PILOTING	
<b>P</b>	39 = Self feeding
	29 = External feeding
VOLTAGE	
<b>T</b>	01 = 12V DC
	02 = 24V DC
	08 = 24V DC 1 Watt

SHORT FUNCTION (Self feeding) "AA"  
SHORT FUNCTION (External feeding) "AE"  
Weight 280 g

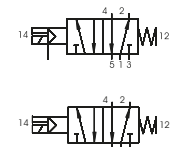
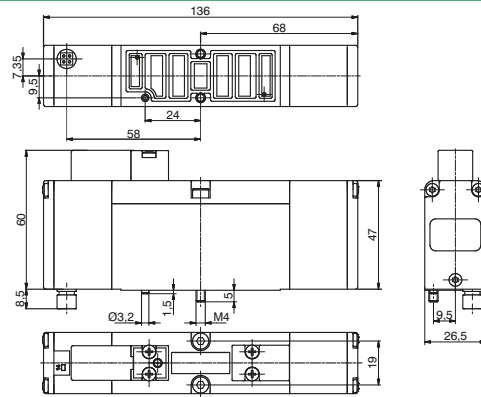

The "Activations time" values, are valid only for the 2,3W versions

**Solenoid-Differential**

Coding: 2741.52.00.**P.T**

Operational characteristics	
Fluid	Filtered air. No lubrication needed, if applied it shall be continuous
Working pressure (bar)	From vacuum to 10
Minimum piloting pressure (bar)	2
Temperature °C	-5 ÷ +50
Flow rate at 6 bar with Δp=1 (NI/min)	1000
Response time according to ISO 12238, activation time (ms)	20
Response time according to ISO 12238, deactivation time (ms)	38

*Shifting time of pneumatic directional control valves or moving parts, logic devices were measured in accordance to ISO 12238:2001*

PILOTING	
<b>P</b>	36 = Self feeding
	26 = External feeding
VOLTAGE	
<b>T</b>	01 = 12V DC
	02 = 24V DC
	08 = 24V DC 1 Watt

SHORT FUNCTION (Self feeding) "BA"  
SHORT FUNCTION (External feeding) "BE"  
Weight 280 g

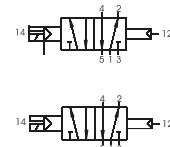
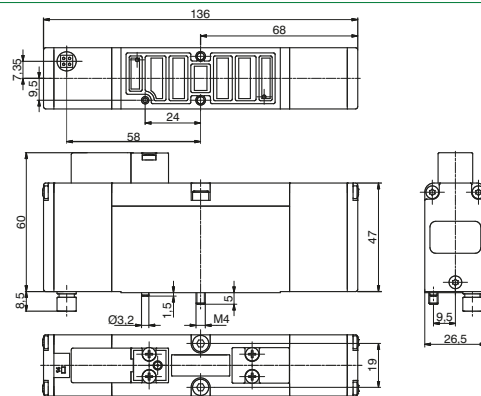

The "Activations time" values, are valid only for the 2,3W versions

**Solenoid-Solenoid 5/2**

Coding: 2741.52.00.**P.T**

Operational characteristics	
Fluid	Filtered air. No lubrication needed, if applied it shall be continuous
Working pressure (bar)	From vacuum to 10
Minimum piloting pressure (bar)	2
Temperature °C	-5 ÷ +50
Flow rate at 6 bar with Δp=1 (NI/min)	1000
Response time according to ISO 12238, activation time (ms)	12
Response time according to ISO 12238, deactivation time (ms)	14

*Shifting time of pneumatic directional control valves or moving parts, logic devices were measured in accordance to ISO 12238:2001*

PILOTING	
<b>P</b>	35 = Self feeding
	24 = External feeding
VOLTAGE	
<b>T</b>	01 = 12V DC
	02 = 24V DC
	08 = 24V DC 1 Watt

SHORT FUNCTION (Self feeding) "CA"  
SHORT FUNCTION (External feeding) "CE"  
Weight 310 g

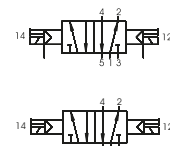
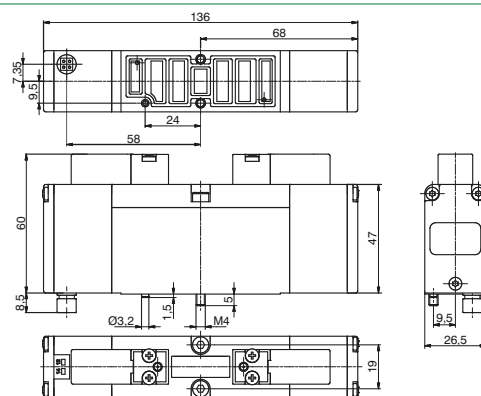

The "Activations time" values, are valid only for the 2,3W versions

**Solenoid-Solenoid 5/3**

Coding: 2741.53.31.P.T

Operational characteristics	
Fluid	Filtered air. No lubrication needed, if applied it shall be continuous
Working pressure (bar)	From vacuum to 10
Minimum piloting pressure (bar)	3
Temperature °C	-5 ÷ +50
Flow rate at 6 bar with Δp=1 (NI/min)	660
Response time according to ISO 12238, activation time (ms)	12
Response time according to ISO 12238, deactivation time (ms)	60

*Shifting time of pneumatic directional control valves or moving parts, logic devices were measured in accordance to ISO 12238:2001*

PILOTING	
<b>P</b>	35 = Self feeding
	24 = External feeding
VOLTAGE	
<b>T</b>	01 = 12V DC
	02 = 24V DC
	08 = 24V DC 1 Watt

SHORT FUNCTION (Self feeding) "EA"  
SHORT FUNCTION (External feeding) "EE"

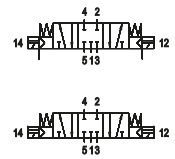
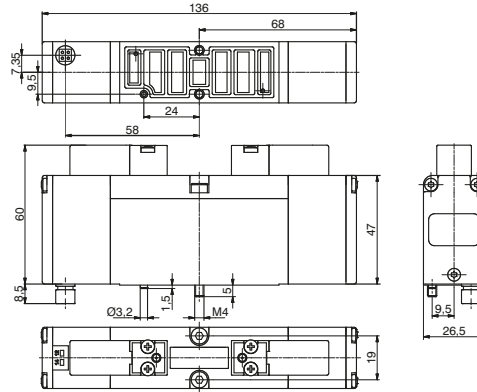

Weight 310 g  
The "Activations time" values, are valid only for the 2,3W versions

1  
AIR DISTRIBUTION

**Solenoid-Solenoid 2x3/2 (Self feeding / External feeding)**

Coding: 2741.62.F.P.T

Operational characteristics	
Fluid	Filtered air. No lubrication needed, if applied it shall be continuous
Working pressure (bar)	From vacuum to 10
Minimum piloting pressure (bar)	≥2+(0,3xP.alim.)
Temperature °C	-5 ÷ +50
Flow rate at 6 bar with Δp=1 (NI/min)	550
Response time according to ISO 12238, activation time (ms)	15 (Self feeding) 12 (External feeding)
Response time according to ISO 12238, deactivation time (ms)	15 (Self feeding) 60 (External feeding)

*Shifting time of pneumatic directional control valves or moving parts, logic devices were measured in accordance to ISO 12238:2001*

FUNCTION	
<b>F</b>	44 = 2 Coils 3/2 NC
	45 = 1 Coil 3/2 NC (14) + 1 Coil 3/2 NO (12)
	55 = 2 Coils 3/2 NO
	54 = 1 Coil 3/2 NO (14) + 1 Coil 3/2 NC (12)
PILOTING	
<b>P</b>	35 = Self feeding
	24 = External feeding
VOLTAGE	
<b>T</b>	01 = 12V DC
	02 = 24V DC
	08 = 24V DC 1 Watt

SHORT FUNCTION (Self feeding):  
2/3/2 NC="FA"  
13/2 NC (14) + 1 3/2 NA (12)="HA"  
2/3/2 NA="GA"  
13/2 NA (14) + 1 3/2 NC (12)="IA"  
SHORT FUNCTION (External feeding):  
2/3/2 NC="FE"  
13/2 NC (14) + 1 3/2 NA (12)="HE"  
2/3/2 NA="GE"  
13/2 NA (14) + 1 3/2 NC (12)="IE"

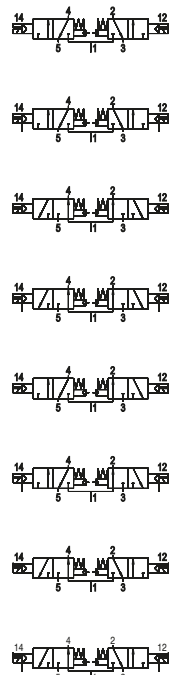
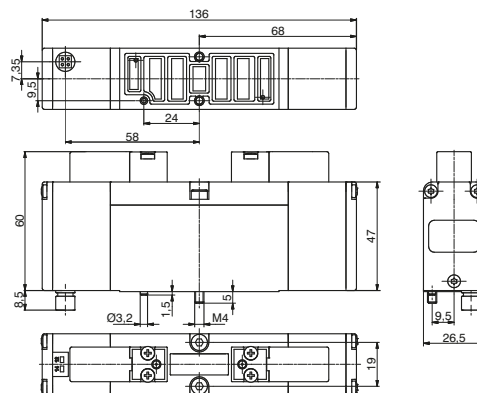

Weight 310 g  
The "Activations time" values, are valid only for the 2,3W versions  
\*Example: If inlet pressure is set at 5bar then pilot pressure must be at least  
Pp=2+(0.3\*5)=3,5bar"

Right Endplates

Coding: 2740.02.Ⓒ

Operational characteristics	
Fluid	Filtered air. No lubrication needed, if applied it shall be continuous
Working pressure (bar)	From vacuum to 10
Temperature °C	-5 ÷ +50

ELECTRICAL CONNECTION	
37P	= Connectors 37 poles
PNP	
25P	= Connectors 25 poles
Ⓒ PNP	
37N	= Connectors 37 poles
NPN	
25N	= Connectors 25 poles
NPN	

Weight 600 g

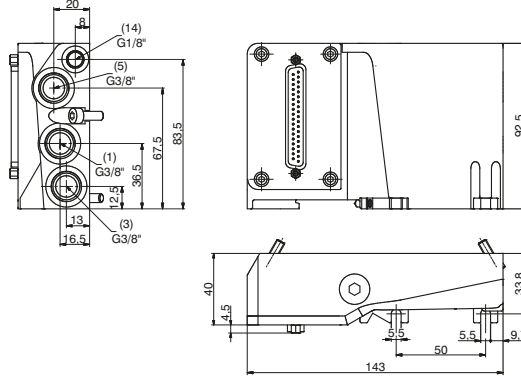
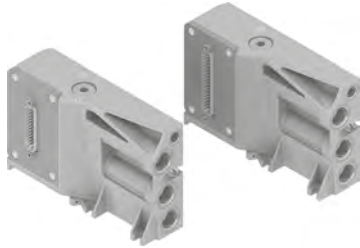

Left Endplates

Coding: 2740.03.Ⓒ

Operational characteristics	
Fluid	Filtered air. No lubrication needed, if applied it shall be continuous
Working pressure (bar)	From vacuum to 10
Temperature °C	-5 ÷ +50

ELECTRICAL CONNECTION	
Ⓒ 00	= Electrical connection
25P	= Connectors 25 poles

Weight 600 g

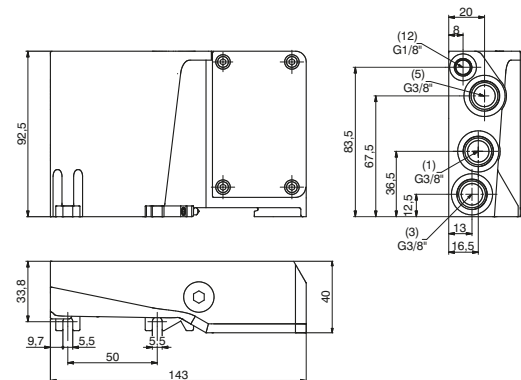

Modular base

Coding: 2740.01.Ⓥ

Operational characteristics	
Fluid	Filtered air. No lubrication needed, if applied it shall be continuous
Working pressure (bar)	From vacuum to 10
Temperature °C	-5 ÷ +50

VERSION	
Ⓥ M	= for Monostable SV
B	= for Bistable SV

Weight 330 g

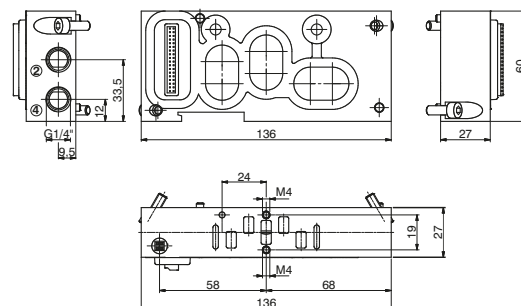

**Closing plate**

Coding: 2740.00

Weight 100 g

Operational characteristics	
Fluid	Filtered air. No lubrication needed, if applied it shall be continuous
Working pressure (bar)	From vacuum to 10
Temperature °C	-5 ÷ +50

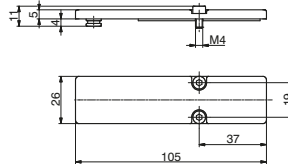

**Diaphragm plug**

Coding: 2740.17



Weight 65 g

**Cable complete with connector, 25 Poles IP65**

Coding: 2300.25.L.C



L	CABLE LENGTH
	03 = 3 meters
	05 = 5 meters
F	FUNCTION
	31 = Closed centres
	32 = Open centres
	33 = Pressured centres

**Cable complete with connector, 37 Poles IP65**

Coding: 2400.37.L.C



L	CABLE LENGTH
	03 = 3 meters
	05 = 5 meters
F	FUNCTION
	31 = Closed centres
	32 = Open centres
	33 = Pressured centres

**Cable complete with connector, 25 Poles IP65**

Coding: 2400.25.L.25



L	CABLE LENGTH
	03 = 3 meters
	05 = 5 meters
	10 = 10 meters

The electrical connection is achieved by a 37 pin connector and can manage up to 32 solenoid pilots. It is also possible use a 25 sub-D pin connector and, in this case, it is possible to manage a maximum of 22 outputs. The management and distribution of the electrical signals between each valve is obtained thanks to an electrical connector which receives the signals from the previous module, uses one, two or none depending on the type, and carries forward to the next module the remaining.

Bistable valves, 5/3 and 2x3/2 valves which have two solenoid pilots built in, use two signals; the first is directed to the pilot side 14 the second to the pilot side 12. Modular bases can be fitted with two type of electrical connector: the monostable version uses only one signal (connected to the pilot side 14) and carries forward the remaining, the bistable version which always uses two signals.

This solution allows the modification of the manifold (replacement of monostable valves without bistable for example) without having to reset the PLC output layout.

On other hand this solution limits the maximum number of valves to 16 when it is used a 37 pin connector or 11 when it is used a 25 pin connector.

Intermediate supply/exhaust module uses an electrical connector directly forwarding signals to the next one without any kind of modification.

This allows the use of intermediate modules in any position of the manifold.

All the electrical signals that have not been used on the manifold can be used placing at the end of the manifold the end plate complete with the 25 sub-D female connector.

The number of available signals depends of the connector used to the type of the left end plate and by the total signals used along the manifold:

37 pin connector	nr of output = 32 – (total of used signals)
25 pin connector	nr of output = 22 – (total of used signals)

Following we show some examples of possible combination and the relative pin assignment.

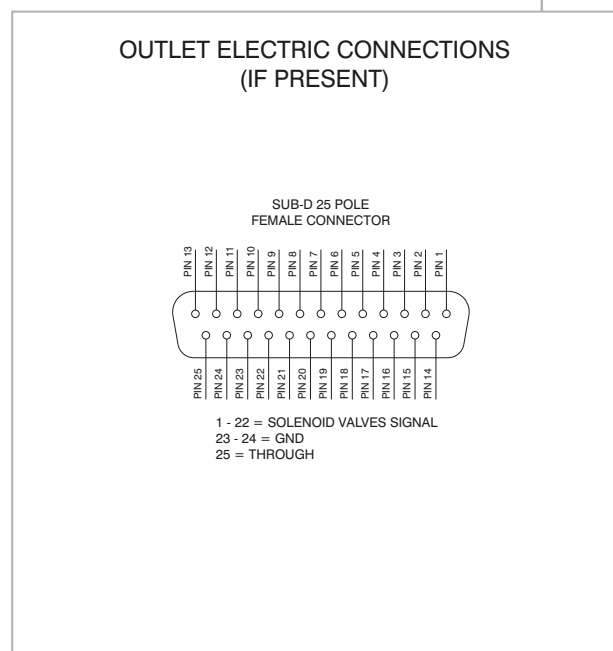
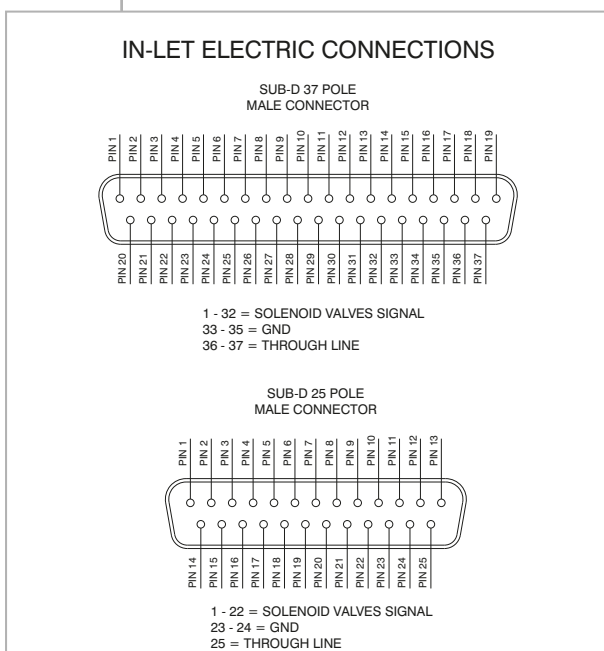
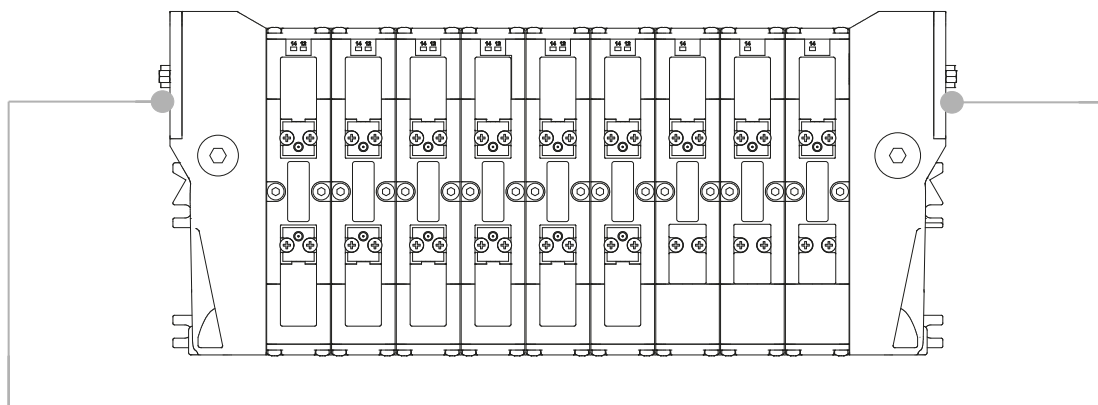

**37 PIN Connector correspondence for valves assembled on mixed bases**

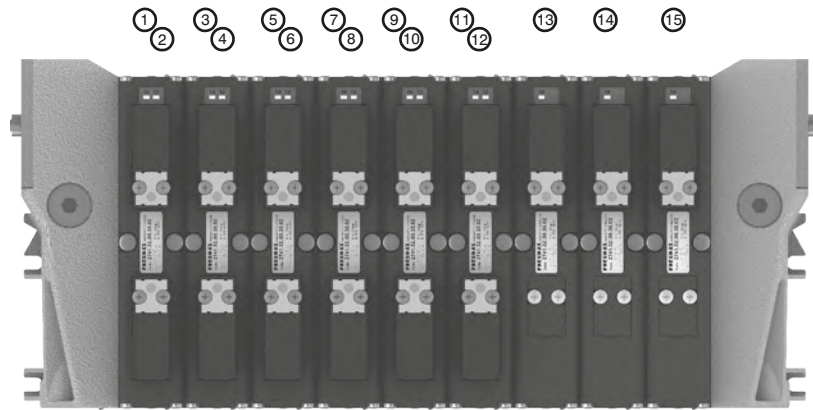

- PIN 1 = PILOT 14 SV POS.1
- PIN 2 = PILOT 12 SV POS.1
- PIN 3 = PILOT 14 SV POS.2
- PIN 4 = PILOT 12 SV POS.2
- PIN 5 = PILOT 14 SV POS.3
- PIN 6 = PILOT 12 SV POS.3
- PIN 7 = PILOT 14 SV POS.4
- PIN 8 = PILOT 12 SV POS.4
- PIN 9 = PILOT 14 SV POS.5
- PIN 10 = PILOT 12 SV POS.5
- PIN 11 = PILOT 14 SV POS.6
- PIN 12 = PILOT 12 SV POS.6
- PIN 13 = PILOT 14 SV POS.7
- PIN 14 = PILOT 14 SV POS.8
- PIN 15 = PILOT 14 SV POS.9

POS.	1	2	3	4	5	6	7	8	9
------	---	---	---	---	---	---	---	---	---

**37 PIN Connector correspondence for manifold mounted on bases for bistable valves**

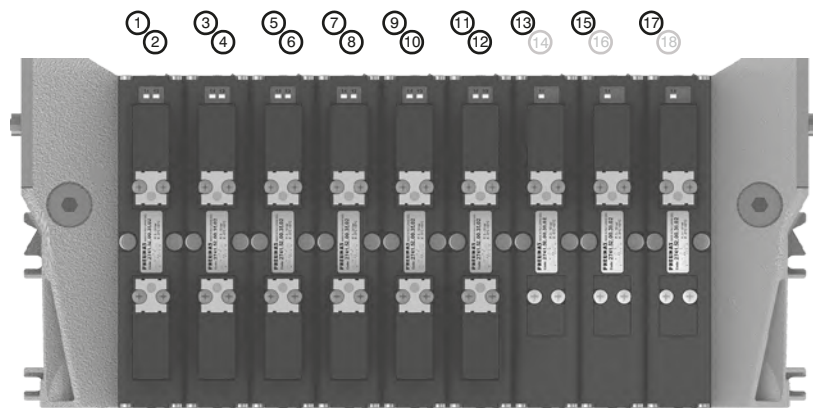

- PIN 1 = PILOT 14 SV POS.1
- PIN 2 = PILOT 12 SV POS.1
- PIN 3 = PILOT 14 SV POS.2
- PIN 4 = PILOT 12 SV POS.2
- PIN 5 = PILOT 14 SV POS.3
- PIN 6 = PILOT 12 SV POS.3
- PIN 7 = PILOT 14 SV POS.4
- PIN 8 = PILOT 12 SV POS.4
- PIN 9 = PILOT 14 SV POS.5
- PIN 10 = PILOT 12 SV POS.5
- PIN 11 = PILOT 14 SV POS.6
- PIN 12 = PILOT 12 SV POS.6
- PIN 13 = PILOT 14 SV POS.7
- PIN 14 = NOT CONNECTED
- PIN 15 = PILOT 14 SV POS.8
- PIN 16 = NOT CONNECTED
- PIN 17 = PILOT 14 SV POS.9
- PIN 18 = NOT CONNECTED

POS.	1	2	3	4	5	6	7	8	9
------	---	---	---	---	---	---	---	---	---

**37 PIN Connector correspondence for manifold for 32 position manifold with monostable valves on base**

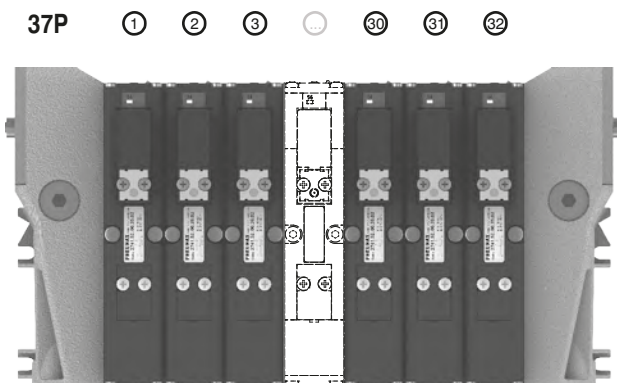

POS.	1	2	3	...	30	31	32
------	---	---	---	-----	----	----	----

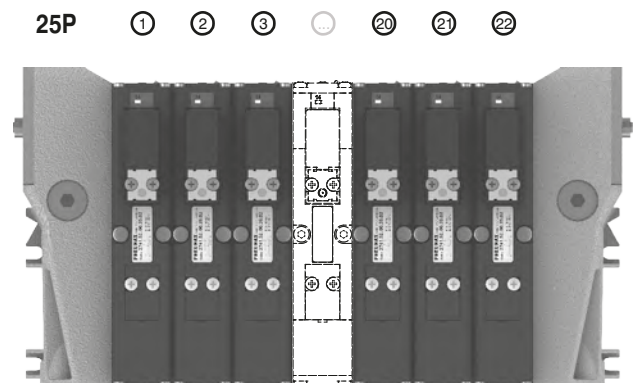

POS.	1	2	3	...	20	21	22
------	---	---	---	-----	----	----	----

1  
AIR DISTRIBUTION

**General :**

Using the 2740.03.25P output terminal it is possible to make any electrical signals not used by valves available on a 25 sub-D female connector at the right end of the manifold.  
 It is possible to then join a multi-core cable to link to the next manifold, or connect directly to one or two I/O modules.  
 The I/O modules can accept input or output signals, depending upon what is connected.

**Ordering code**

**2540.08T**



**Please note:** If the manifold is connected by a multi-core connection, each connection can be used as either an input or an output, while if the manifold is connected to a serial node the connections can only be used as an output.

It is possible to connect the manifold to up to two I/O modules.

Each I/O module includes 8 diagnostic LEDs which indicate the presence of an Input / Output signal for each connector.

**Please note:** For an LED to function, a signal of at least +15VDC must be present on pin 4 of the connector. If this signal is lower, the LED will not light, this does not compromise the normal Input / Output function of the unit.

**Overall dimensions and I/O layout :**

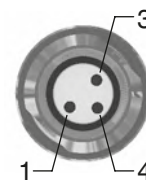
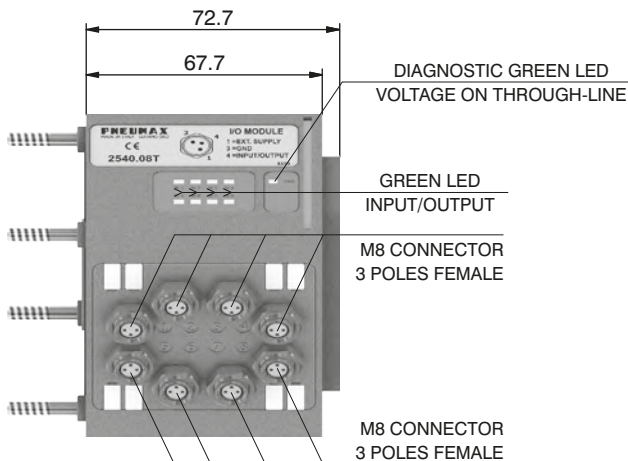

PIN	DESCRIPTION
1	+24 VDC
4	INPUT/OUTPUT
3	GND

**Input features:**

Each connection can accept either two wire (switches, magnetic switches, pressure switches, etc.) or three wire connections (photocells, electronic end of stroke sensors, etc.) If +24VDC is required on at Pin 1 of each connector, it is possible to provide this via the through-line pin of the multi-pole connector.

I.E :

Pin 25 of the 25 pin multi-pole connector (code 2740.02.25P or 2740.12.25P)

Pin 36-37 of the 37 pin multi-pole connector (code 2740.02.37P or 2740.12.37P)

**Output features:**



**Attention:** The output connections are not protected against short-circuit. Please pay attention when wiring (avoid Pin 4 being connected to Pin 3 or Pin 1).

General characteristics	Model	2540.08T
	Case	Reinforced technopolymer
	I/O Connector	M8 connector 3 poles female (IEC 60947-5-2)
	PIN 1 voltage (connector used as Input)	By the user
	PIN 4 voltage diagnosis	Green Led
	Node consumption (Outlets excluded)	7mA per each LED with 24 VDC signal
	Outlets voltage	+23,3 VDC (serial) /by the user (multipolar)
	Input voltage	Depend by the using
	Maximum outlet current	100 mA (serial) / 400 mA (multipolar)
	Maximum Input/Output	8 per module
	Multiconnector max. Current	100 mA
	Connections to manifold	Direct connection to 25 poles connector
	Maximum n. of moduls	2
	Protection degree	IP65 when assembled
	Ambient temperature	from -0° to +50° C

1  
AIR DISTRIBUTION





CORRESPONDENCE BETWEEN MULTI-POLE SIGNAL AND CONNECTOR

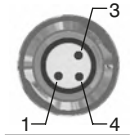
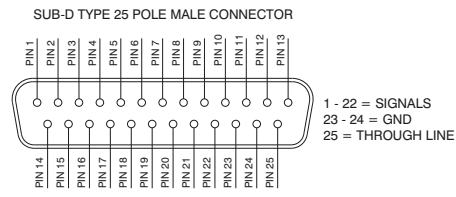
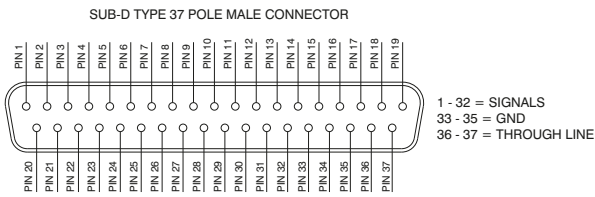

PIN DESCRIPTION	
1	THROUGH LINE
4	SIGNAL
3	GND

Connection modes:

The I/O module changes its operation depending on the way the manifold is controlled. There are two possible modes:

- A) Control via multi-pole connection
- B) Control via fieldbus

In order to use the I/O module, the correct right hand endplate with 25 pole female outlet connector must be used.  
(Code 2740.03.25P).



A) Control via multi-pole :

M8 connector used as Input:



**Attention:** Voltage applied to each connector is passed to multi-pole connector pin.

M8 connector used as Output:

Output voltage will be the same as is applied at the multi-pole connector pin.

The maximum output current depends upon the power unit used, but we recommend no more than 250mA.



**Attention:** Since every cable has a degree of resistance, there will always be a voltage drop depending on the cable's length, sectional area and the current.

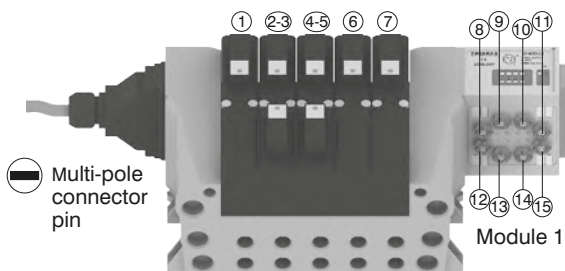
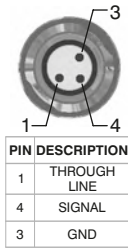

**Attention:** Only one more I/O module can be added.

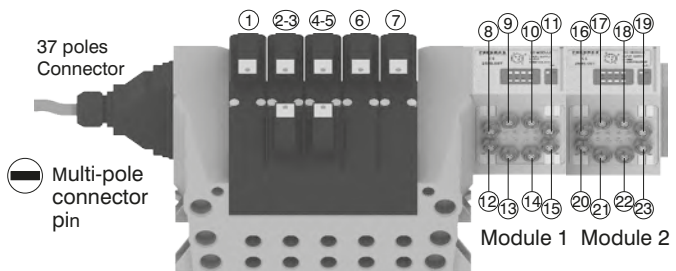

**Attention:** No more additions are possible

**Attention :** 2700 solenoid valve manifolds permit up to 22 electrical signals that are not used by manifolds to be made available: these signals can be managed by another manifold and / or by I/O modules. The I/O module will manage these unused signals. Connections that are not managing useful signals will remain unconnected.

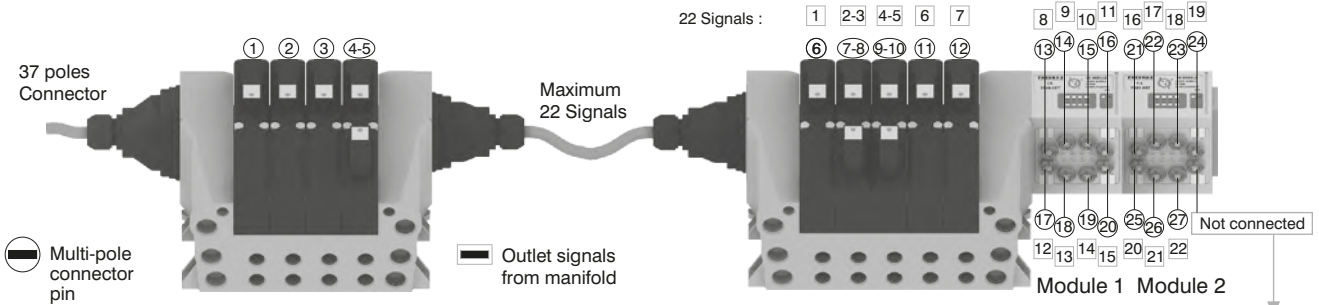

**Attention:** Signal Not connected  
GND Connected  
Through line Connected

**Please note:** this example considers a 37 pin multi-pole connector. The same configuration managed by a 25 pin multi-pole connector will stop at number 22 of multi-pole connector and at number 17 of the manifold. 22 17

1  
AIR DISTRIBUTION

**Please note:** 2700 solenoid valve manifolds manage up to 32 signals. If the manifold uses more than 24 signals the I/O module will manage only the remainder. Connections that are not managing useful signals will remain unconnected.

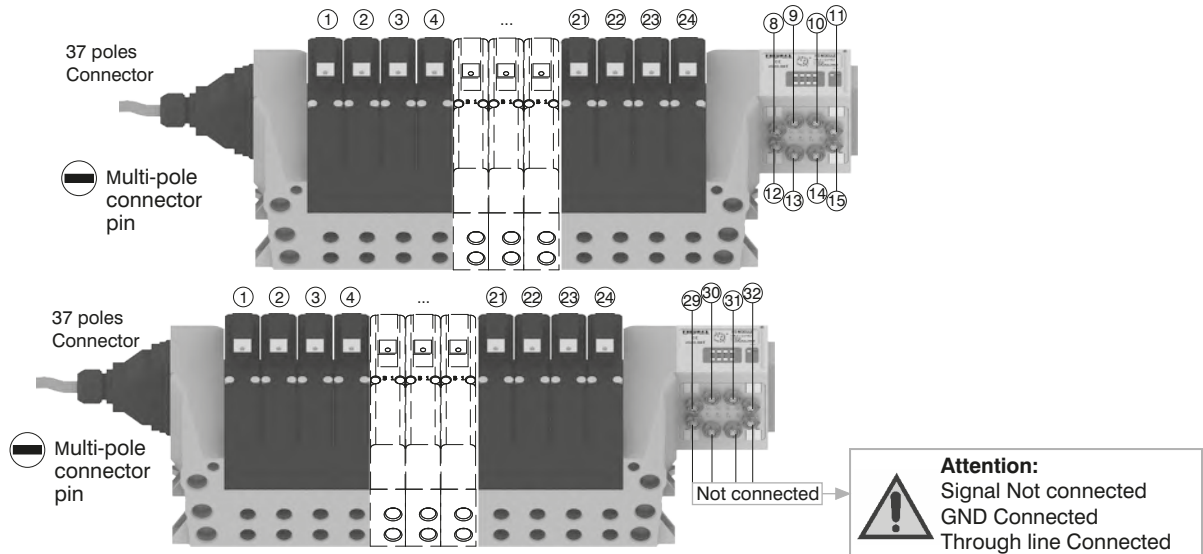

**B) Control via fieldbus:**

With this kind of control the I/O module can only be used as an output. Pin 1 of each connector is not connected. The output voltage will be 0.7V lower than that applied to Pin 4 of the connector.

The maximum output current for each output is 100mA. The correspondence between control byte and each single output depends on how many electrical signals are used by the manifold and by the relative position of the I/O module.

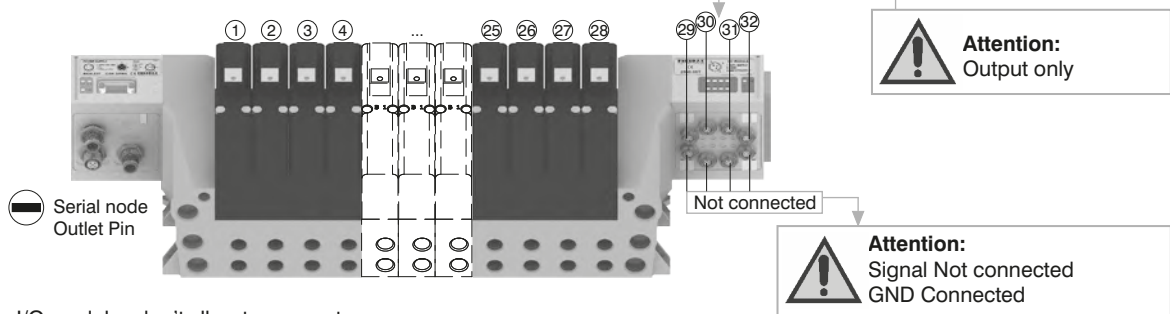
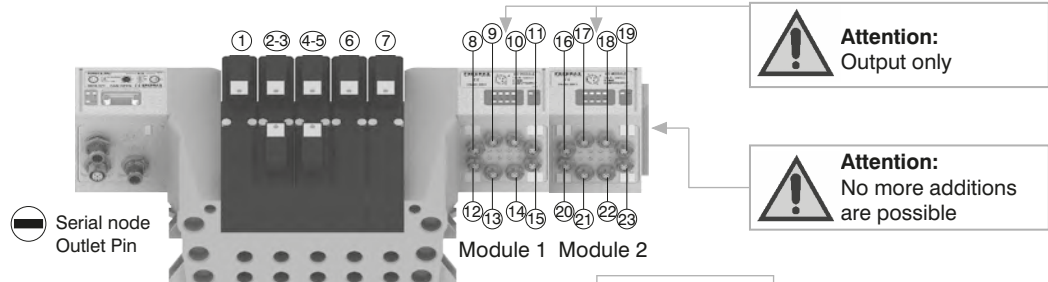
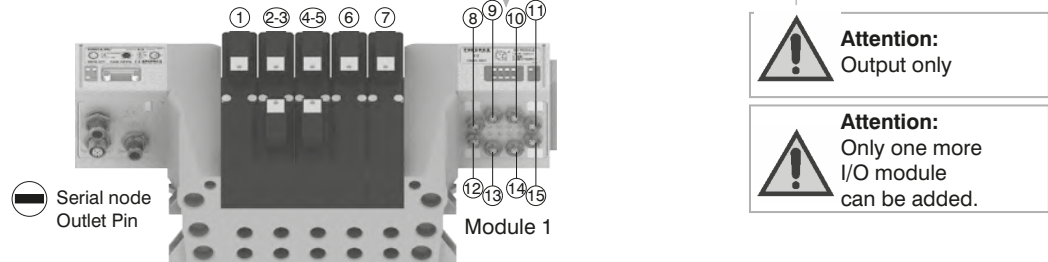
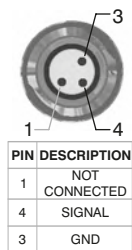

**Please note:** I/O modules don't allow to connect any additional valves manifold after them.

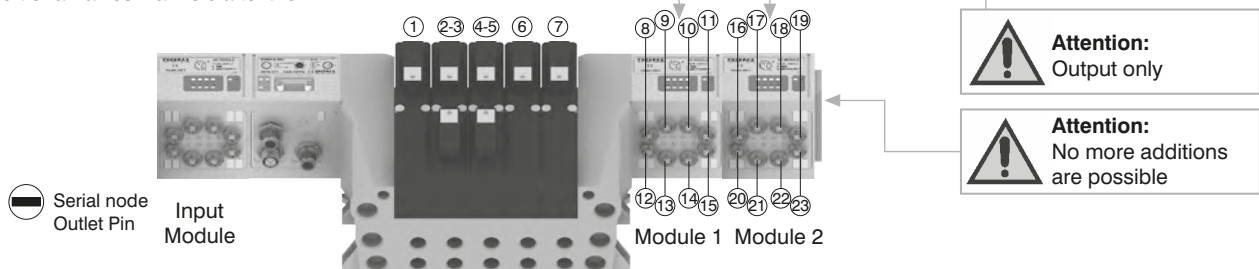

1 AIR DISTRIBUTION

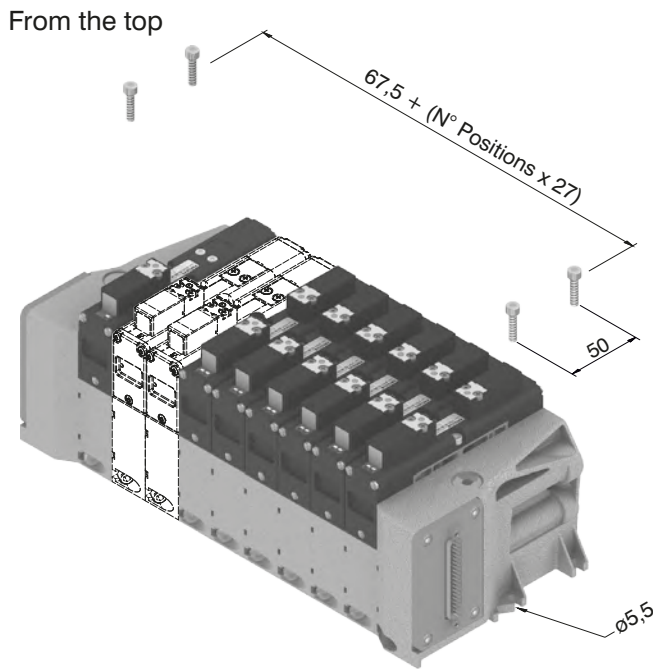

DIN rail fixing

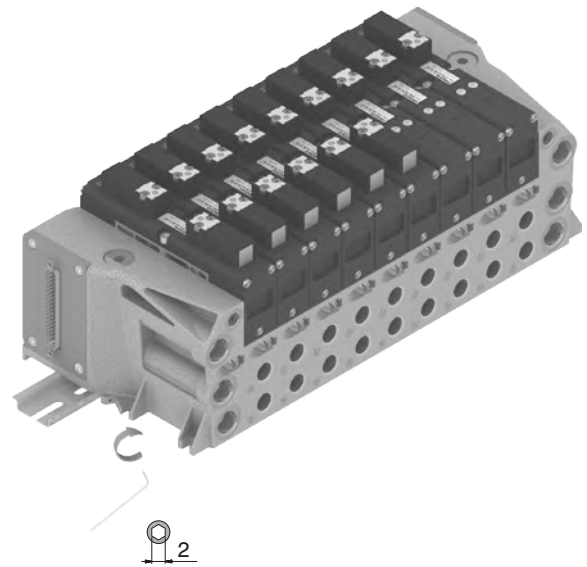

1  
AIR DISTRIBUTION

Maximum possible size according to valves seats

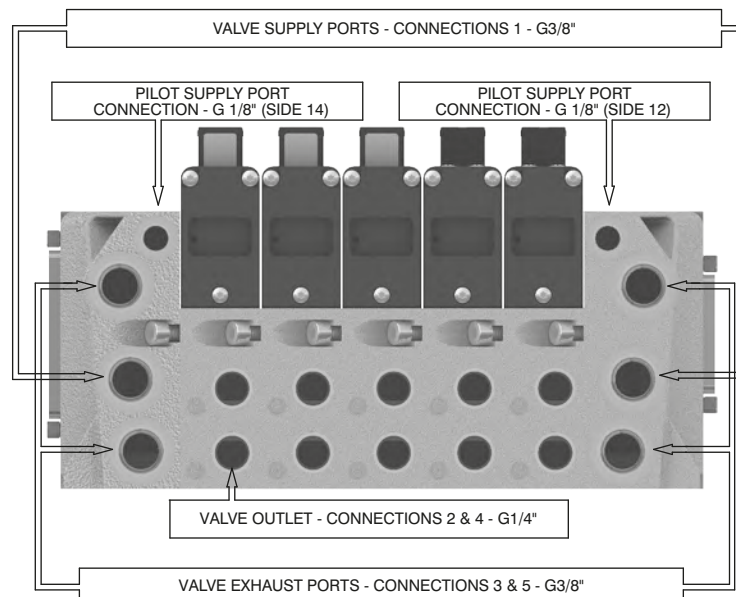
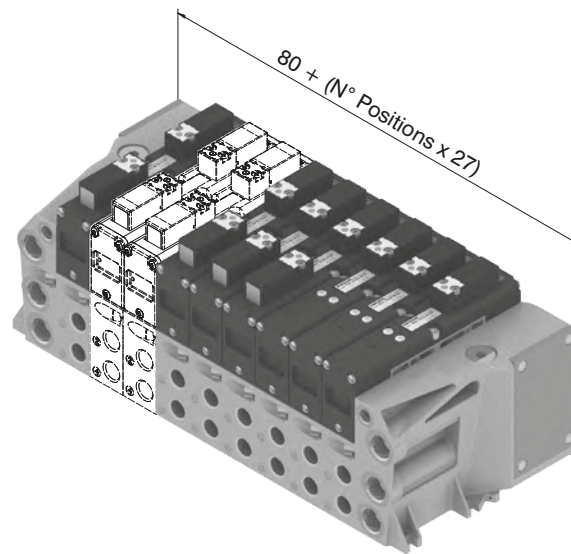

Manifold Layout configuration

1 AIR DISTRIBUTION

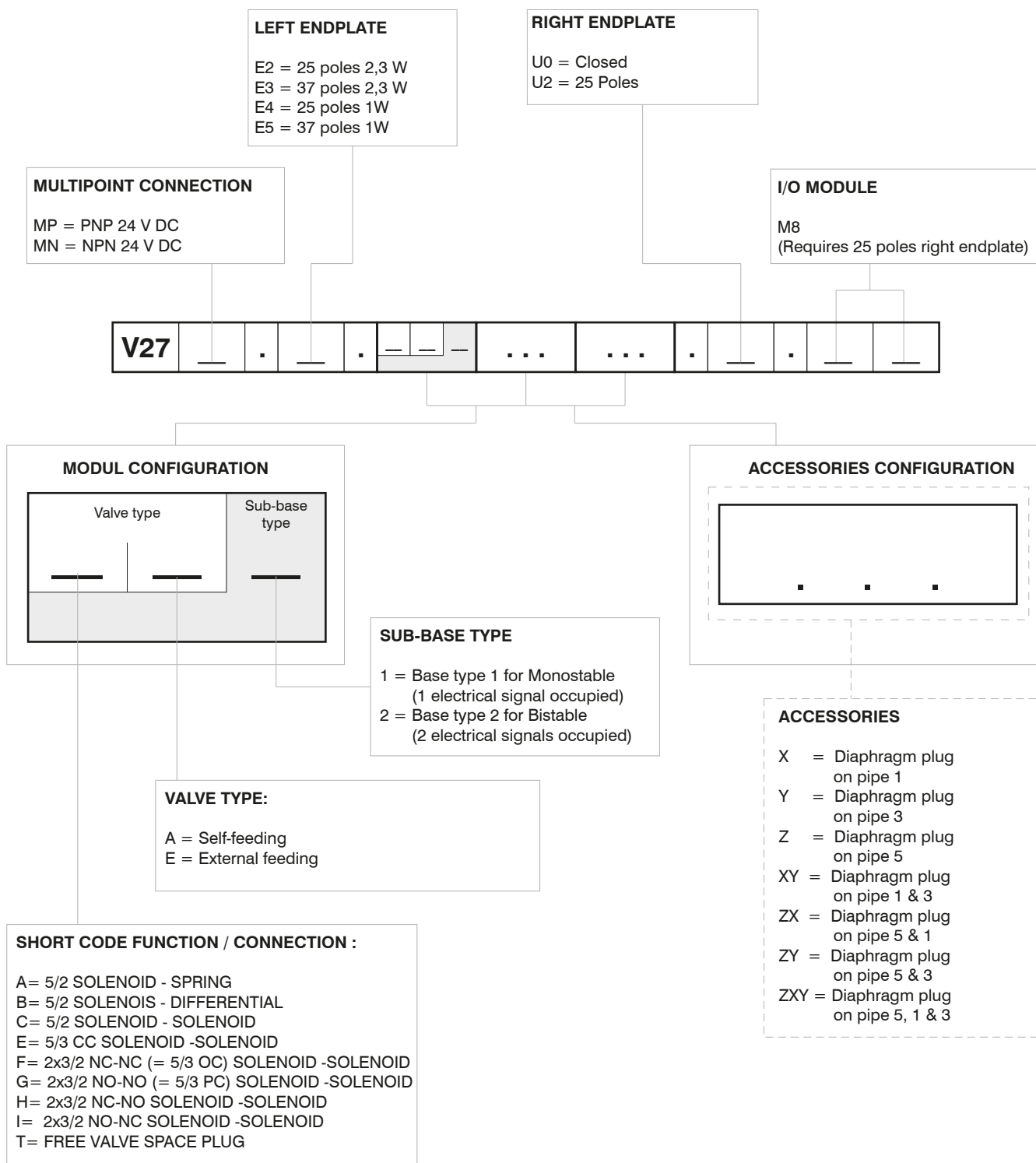

**NOTE:**

While configuring the manifold always be careful that the maximum number of electrical signals available is:

32 when an input 37 poles endplate is used.

22 when an input 25 poles endplate is used.

The use of monostable valve mounted on a base type 2 (2 electrical signals occupied) causes the loss of one electric signal.

In this case the monostable valve can be replaced by a bistable valve. The diaphragms plugs are used to intercept the conduits 1,3 & 5 of the base. If it is necessary to interrupt more than one conduit in the same time then put in line the letters which identifies the position (for example : regarding the 3 & 5 conduits, put the Y & Z letters).

Should one or more conduits be cut more than one time it is necessary to add the relevant intermediate Supply/Exhaust module.



**General:**

CANopen® module is directly integrated on 2700 solenoid valves manifold via a 37 poles connector, normally used for multipolar cable connection.  
2700 series solenoid valves connected to node must be PNP equivalent (final 02 in ordering code).

The node can be easily installed also on solenoid valves manifold already mounted on equipment.

Module can manage up to 32 solenoid valves, and, in the same time, a max number of 4 Input modules 5225.08T or a max number of 4 Input modules 5225.12T.

CANopen® module recognizes automatically the presence of the Input modules on power on. Regardless of the number of Input modules connected, the manageable solenoid valves are 32.

Node power supply is made by a M12 4P male circular connector.

The separation between node 24 VDC Power supply and outputs 24 VDC allows to switch off the outputs maintaining powered the node and inputs, if present.

Connection to Bus CANopen® is possible via 2 M12 5P male - female circular connectors; these two are connected in parallel and according to CiA Draft Recommendation 303-1 (V. 1.3 : 30 December 2004).

Transmission speed can be set by 3 dip-switches.

The node address can be set by 6 dip-switches using BCD numeration.

The module includes an internal terminating resistance that can be activated by a dip-switch.

**Ordering code**

**5525.32T**



1

AIR DISTRIBUTION

**Scheme / Overall dimensions and I/O layout :**

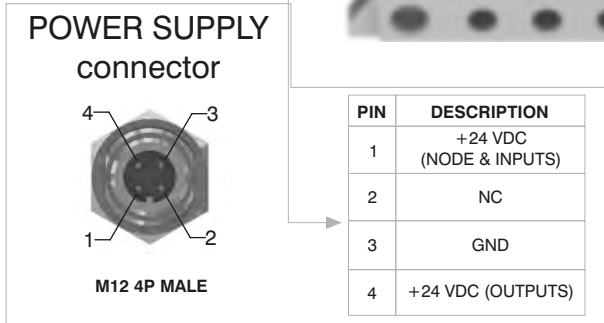
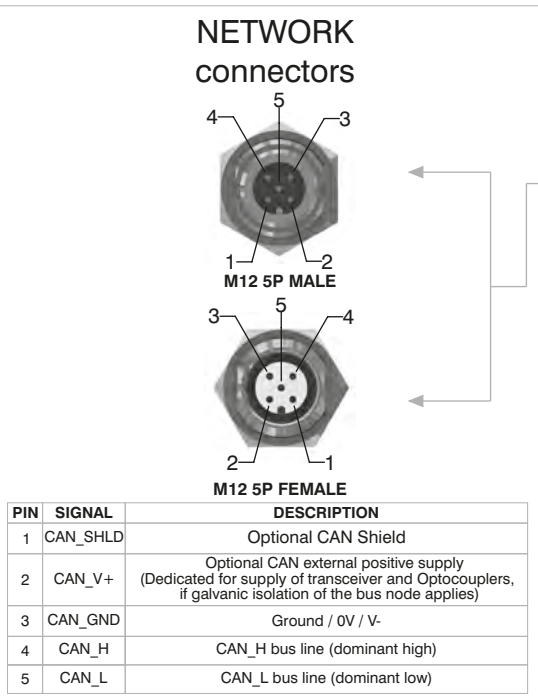
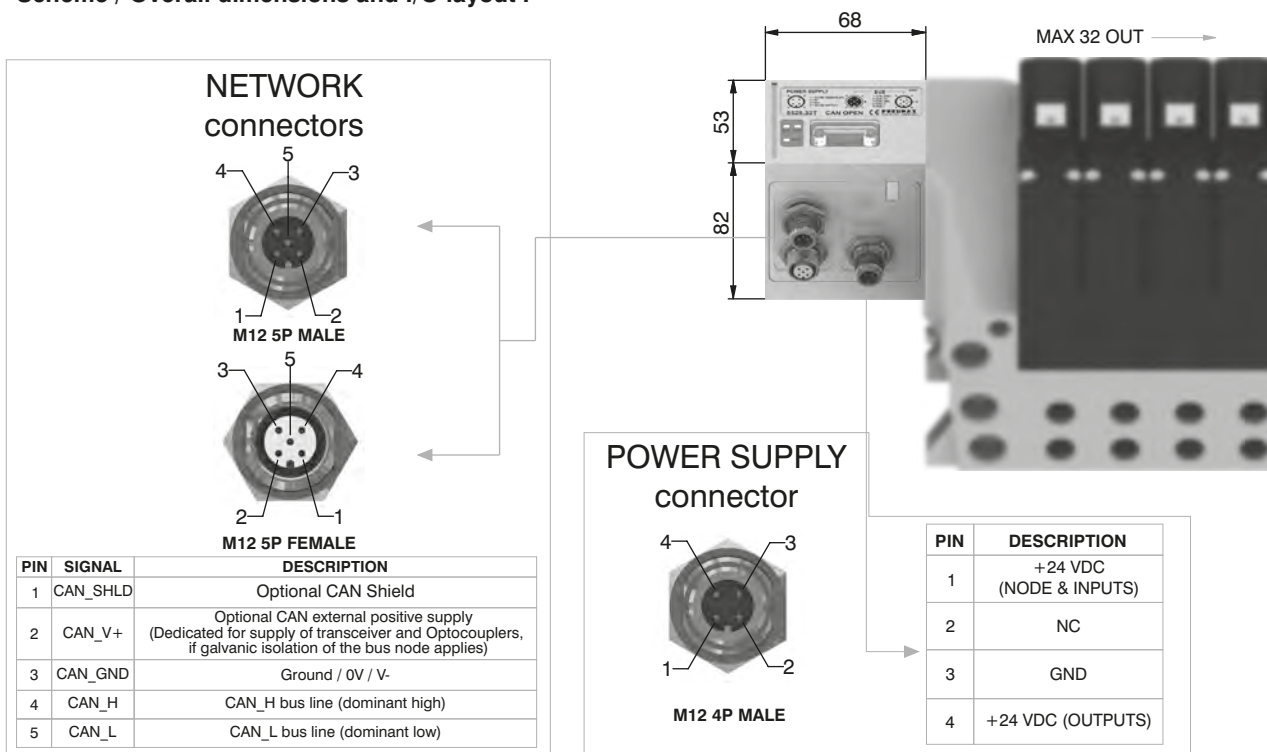

**Technical characteristics**

	Model	5525.32T
	Specifications	CiA Draft Standard Proposal 301 V 4.10 (15 August 2006)
	Case	Reinforced technopolymer
<b>Power supply</b>	Power supply connection	M12 4P male connector (IEC 60947-5-2)
	Power supply voltage	+24 VDC +/- 10%
	Node consumption (without inputs)	30 mA
	Power supply diagnosis	Green LED PWR
<b>Outputs</b>	PNP equivalent outputs	+24 VDC +/- 10%
	Maximum current for each output	100 mA
	Maximum output number	32
	Max output simultaneously actuated	32
<b>Network</b>	Network connectors	2 M12 5P connectors male-female Type A (IEC 60947-5-2)
	Baud rate	10 - 20 - 50 - 125 - 250 - 500 - 800 - 1000 Kbit/s
	Addresses, possible numbers	From 1 to 63
	Max nodes in net	64 (slave + master)
	Bus maximum recommended length	100 m at 500 Kbit/s
	Bus diagnosis	Green LED + Red LED
	Configuration file	Available from our web site: <a href="http://www.pneumaxspa.com">http://www.pneumaxspa.com</a>
	IP protection grade	IP65 when assembled
	Temperature range	From 0° to +50° C

**General:**

DeviceNet module is directly integrated on 2700 solenoid valves manifold via a 37 poles connector, normally used for multipolar cable connection.  
 2700 series solenoid valves connected to node must be PNP equivalent (final 02 in ordering code).

The node can be easily installed also on solenoid valves manifold already mounted on equipment.

Module can manage up to 32 solenoid valves, and, in the same time, a max number of 4 Input modules 5225.08T or a max number of 4 Input modules 5225.12T.

DeviceNet module recognizes automatically the presence of the Input modules on power on.

Regardless of the number of Input modules connected, the managable solenoid valves are 32.

Node power supply is made by a M12 4P male circular connector.

The separation between node 24 VDC Power supply and outputs 24 VDC allows to switch off the outputs maintaining powered the node and inputs, if present.

Connection to Bus DeviceNet is possible via 2 M12 5P male - female circular connectors; these two are connected in parallel and according to DeviceNet Specifications Volume I, release 2.0.

Transmission speed can be set by 3 dip-switches.

The node address can be set by 6 dip-switches using BCD numeration.

The module includes an internal terminating resistance that can be activated by a dip-switch.

**Ordering code**

**5425.32T**



1 AIR DISTRIBUTION

**Scheme / Overall dimensions and I/O layout :**

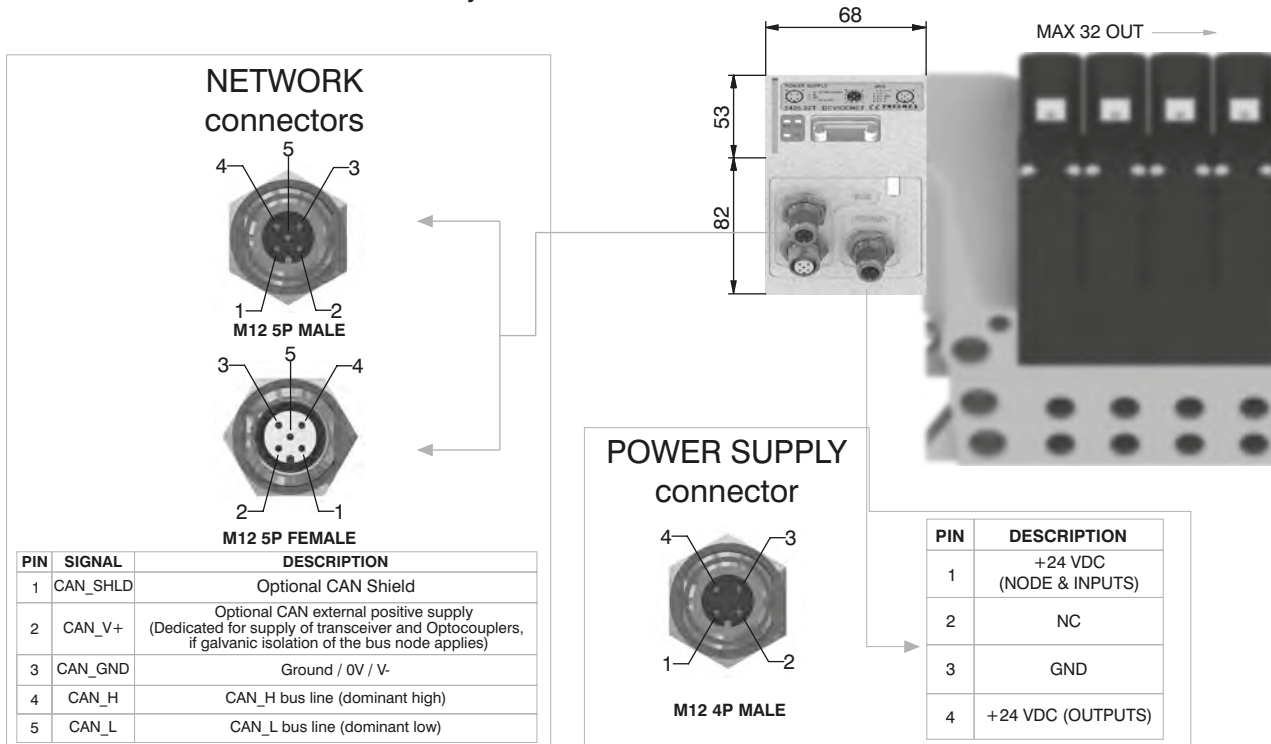

**Technical characteristics**

	Model	5425.32T
	Specifications	DeviceNet Specifications Volume I, release 2.0.
	Case	Reinforced technopolymer
<b>Power supply</b>	Power supply connection	M12 4P male connector (IEC 60947-5-2)
	Power supply voltage	+24 VDC +/- 10%
	Node consumption (without inputs)	30 mA
	Power supply diagnosis	Green LED PWR
<b>Outputs</b>	PNP equivalent outputs	+24 VDC +/- 10%
	Maximum current for each output	100 mA
	Maximum output number	32
	Max output simultaneously actuated	32
<b>Network</b>	Network connectors	2 M12 5P connectors male-female Type A (IEC 60947-5-2)
	Baud rate	125 - 250 - 500 Kbit/s
	Addresses, possible numbers	From 1 to 63
	Max nodes in net	64 (slave + master)
	Bus maximum recommended length	100 m at 500 Kbit/s
	Bus diagnosis	Green LED + Red LED
	Configuration file	Available from our web site: <a href="http://www.pneumaxspa.com">http://www.pneumaxspa.com</a>
	IP protection grade	IP65 when assembled
	Temperature range	From 0° to +50° C



**General:**

PROFIBUS DP module is directly integrated on 2700 solenoid valves manifold via a 37 poles connector, normally used for multipolar cable connection.  
2700 series solenoid valves connected to node must be PNP equivalent (final 02 in ordering code).

The node can be easily installed also on solenoid valves manifold already mounted on equipment.

Module can manage up to 32 solenoid valves, and, in the same time, a max number of 8 Input modules 5225.08T or a max number of 8 Input modules 5225.12T.

PROFIBUS DP module recognizes automatically the presence of the Input modules on power on. Regardless of the number of Input modules connected, the manageable solenoid valves are 32.

Node power supply is made by a M12 4P male circular connector.

The separation between node 24 VDC Power supply and outputs 24 VDC allows to switch off the outputs maintaining powered the node and inputs, if present.

Connection to Bus PROFIBUS DP is possible via 2 M12 type B 5P male - female circular connectors; these two are connected in parallel and according to PROFIBUS Interconnection Technology (Version 1.1 : August 2001).

The node address can be set using BCD numeration: 4 dip-switches for the units and 4 dip-switches for the tens.

The module includes an internal terminating resistance that can be activated by 2 dip-switches.

**Ordering code**

**5325.32T**

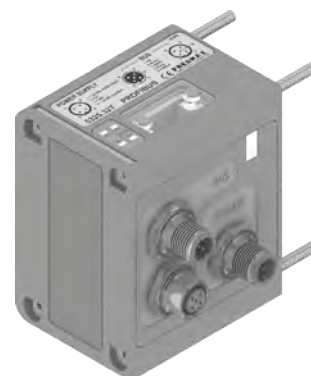

1  
AIR DISTRIBUTION

**Scheme / Overall dimensions and I/O layout :**

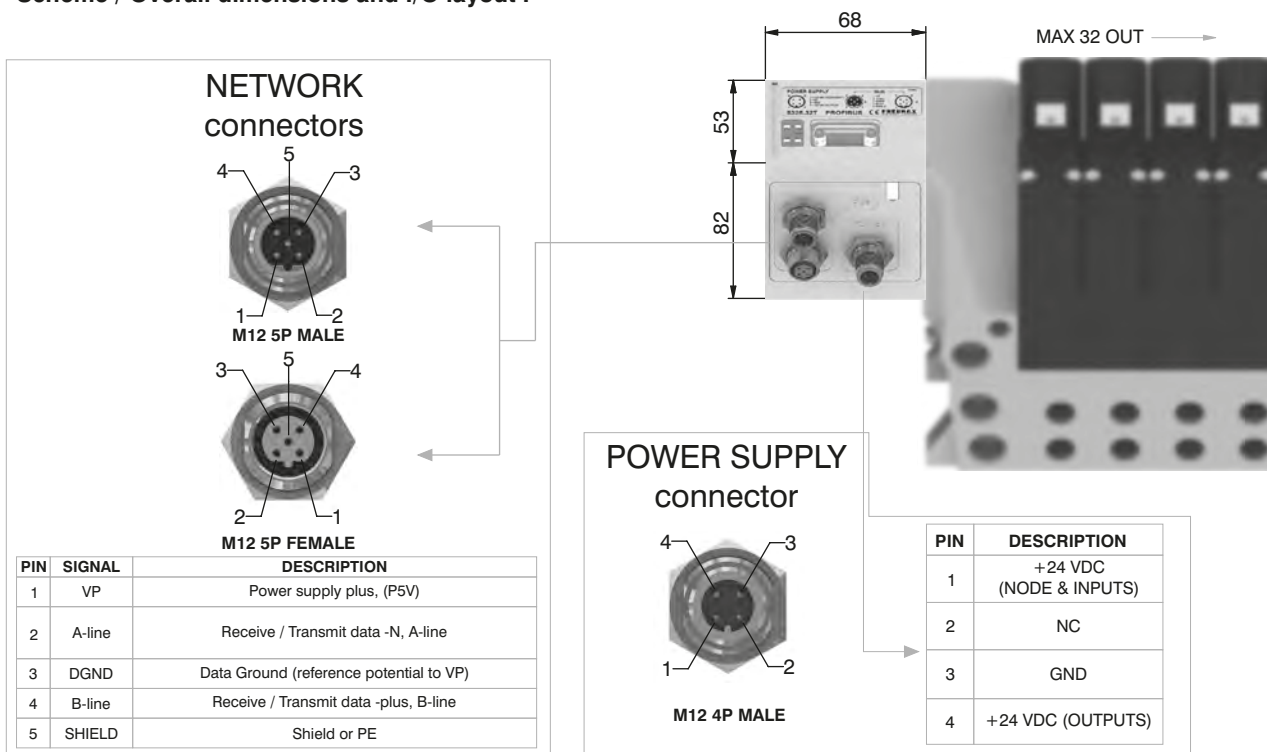

**Technical characteristics**

Model	5325.32T	
Specifications	PROFIBUS DP	
Case	Reinforced technopolymer	
<b>Power supply</b>	Power supply connection	M12 4P male connector (IEC 60947-5-2)
	Power supply voltage	+24 VDC +/- 10%
	Node consumption (without inputs)	50 mA
	Power supply diagnosis	Green LED PWR / Green LED OUT
<b>Outputs</b>	PNP equivalent outputs	+24 VDC +/- 10%
	Maximum current for each output	100 mA
	Maximum output number	32
	Max output simultaneously actuated	32
<b>Network</b>	Network connectors	2 M12 5P male-female connectors Type B
	Baud rate	9,6 - 19,2 - 93,75 - 187,5 - 500 - 1500 - 3000 - 6000 - 12000 Kbit/s
	Addresses, possible numbers	From 1 to 99
	Max nodes in net	100 (slave + master)
	Bus maximum recommended length	100 m at 12 Mbit/s - 1200 m at 9,6 Kbit/s
	Bus diagnosis	Green LED + Red LED
	Configuration file	Available from our web site: <a href="http://www.pneumaxspa.com">http://www.pneumaxspa.com</a>
	IP protection grade	IP65 when assembled
	Temperature range	From 0° to +50° C

**General:**

EtherCAT® module is directly integrated on 2700 solenoid valves manifold via a 37 poles connector, normally used for multipolar cable connection. 2700 series solenoid valves connected to node must be PNP equivalent (final 02 in ordering code).

The node can be easily installed also on solenoid valves manifold already mounted on equipment.

Module can manage up to 32 solenoid valves, and, in the same time, a max number of 4 Input modules 5225.08T or a max number of 4 Input modules 5225.12T.

The EtherCAT® module, regardless the number of Input module connected, reports to have connected 4 Input modules.

Regardless of the number of Input modules connected, the manageable solenoid valves are 32.

Node power supply is made by a M12 4P male circular connector.

The separation between node 24 VDC Power supply and outputs 24 VDC allows to switch off the outputs maintaining powered the node and inputs, if present.

Connection to Bus EtherCAT® is possible via 2 M12 4P type D female circular connectors. These two connectors lead the signal to two different communication ports, so they are not connected in parallel.

The node address is assigned during configuration.

**Note: 5700 series has a different configuration file from series 5600.**

**Ordering code**

**5725.32T.EC**

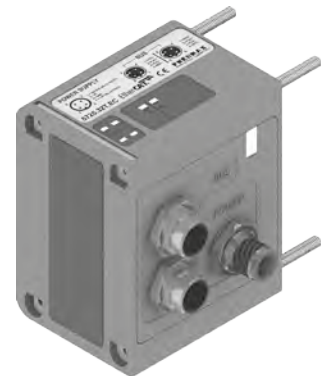

**Scheme / Overall dimensions and I/O layout :**

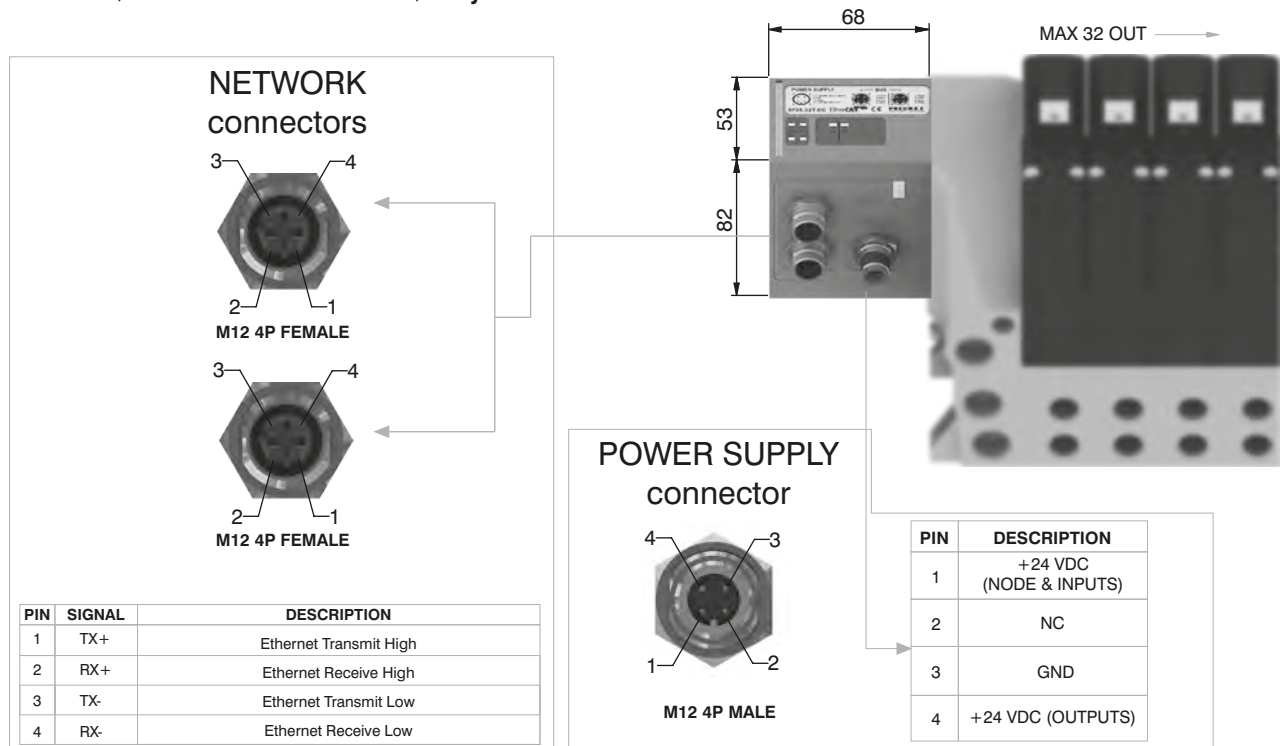

**Technical characteristics**

Model	5725.32T.EC	
Specifications	EtherCAT® Specifications ETG.1000 series	
Case	Reinforced technopolymer	
<b>Power supply</b>	Power supply connection	M12 4P male connector (IEC 60947-5-2)
	Power supply voltage	+24 VDC +/- 10%
	Node consumption (without inputs)	400 mA
	Power supply diagnosis	Green LEDPWR / Green LED OUT
<b>Outputs</b>	PNP equivalent outputs	+24 VDC +/- 10%
	Maximum current for each output	100 mA
	Maximum output number	32
	Max output simultaneously actuated	32
<b>Network</b>	Network connectors	2 M12 4P female connectors Type D (IEC 61076-2-101)
	Baud rate	100 Mbit/s
	Addresses, possible numbers	From 1 to 65535
	Max nodes in net	65536 (Master + Slave)
	Maximum distance between 2 nodes	100 m
	Bus diagnosis	1 green and 1 red LED for status + 2 LEDs for link & activity
	Configuration file	Available from our web site: <a href="http://www.pneumaxspa.com">http://www.pneumaxspa.com</a>
	IP protection grade	IP65 when assembled
	Temperature range	From 0° to +50° C





**General :**

PROFINET IO RT module is directly integrated on 2700 solenoid valves manifold via a 37 poles connector, normally used for multipolar cable connection.  
2700 series solenoid valves connected to node must be PNP equivalent (final 02 in ordering code).

The node can be easily installed also on solenoid valves manifold already mounted on equipment.

Module can manage up to 32 solenoid valves, and, in the same time, a max number of 8 Input modules 5225.08T or a max number of 8 Input modules 5225.12T.

The PROFINET IO RT module, regardless the number of Input module connected, reports to have connected 8 Input modules.

Regardless of the number of Input modules connected, the manageable solenoid valves are 32.

Node power supply is made by a M12 4P male circular connector.

The separation between node 24 VDC Power supply and outputs 24 VDC allows to switch off the outputs maintaining powered the node and inputs, if present.

Connection to Bus PROFINET IO RT is possible via 2 M12 4P type D female circular connectors. These two connectors lead the signal to two different communication ports, so they are not connected in parallel.

The node address is assigned during configuration.

**Ordering code**

**5725.32T.PN**



1  
AIR DISTRIBUTION

**Scheme / Overall dimensions and I/O layout :**

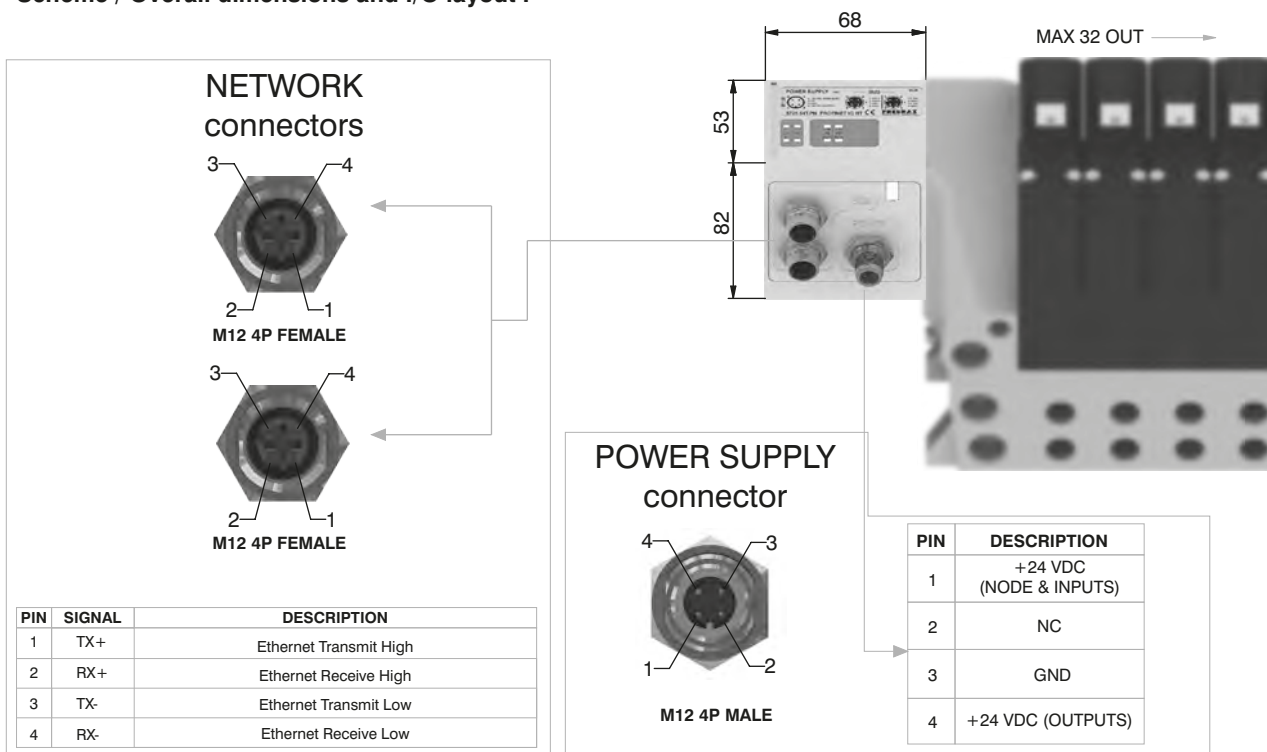

**Technical characteristics**

	Model	5725.32T.PN
	Specifications	PROFINET IO RT
	Case	Reinforced technopolymer
<b>Power supply</b>	Power supply connection	M12 4P male connector (IEC 60947-5-2)
	Power supply voltage	+24 VDC +/- 10%
	Node consumption (without inputs)	400 mA
	Power supply diagnosis	Green LED PWR / Green LED OUT
<b>Outputs</b>	PNP equivalent outputs	+24 VDC +/- 10%
	Maximum current for each output	100 mA
	Maximum output number	32
	Max output simultaneously actuated	32
<b>Network</b>	Network connectors	2 M12 4P female connectors Type D (IEC 61076-2-101)
	Baud rate	100 Mbit/s
	Addresses, possible numbers	As an IP address
	Max nodes in net	As an Ethernet Network
	Maximum distance between 2 nodes	100 m
	Bus diagnosis	1 green and 1 red LED for status + 4 LEDs for link & activity
	Configuration file	Available from our web site: <a href="http://www.pneumaxspa.com">http://www.pneumaxspa.com</a>
	IP protection grade	IP65 when assembled
	Temperature range	From 0° to +50° C

**General :**

EtherNet/IP module is directly integrated on 2700 solenoid valves manifold via a 37 poles connector, normally used for multipolar cable connection.  
 2700 series solenoid valves connected to node must be PNP equivalent (final 02 in ordering code).

The node can be easily installed also on solenoid valves manifold already mounted on equipment.

Module can manage up to 32 solenoid valves, and, in the same time, a max number of 8 Input modules 5225.08T or a max number of 8 Input modules 5225.12T.

The EtherNet/IP module, regardless the number of Input module connected, reports to have connected 8 Input modules.

Regardless of the number of Input modules connected, the managable solenoid valves are 32.

Node power supply is made by a M12 4P male circular connector.

The separation between node 24 VDC Power supply and outputs 24 VDC allows to switch off the outputs maintaining powered the node and inputs, if present.

Connection to Bus EtherNet/IP is possible via 2 M12 4P type D female circular connectors. These two connectors lead the signal to two different communication ports, so they are not connected in parallel.

The node address is assigned during configuration.

**Ordering code**

**5725.32T.EI**

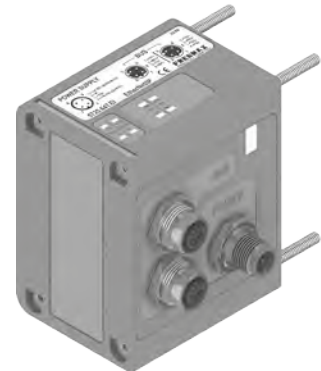

**Scheme / Overall dimensions and I/O layout :**

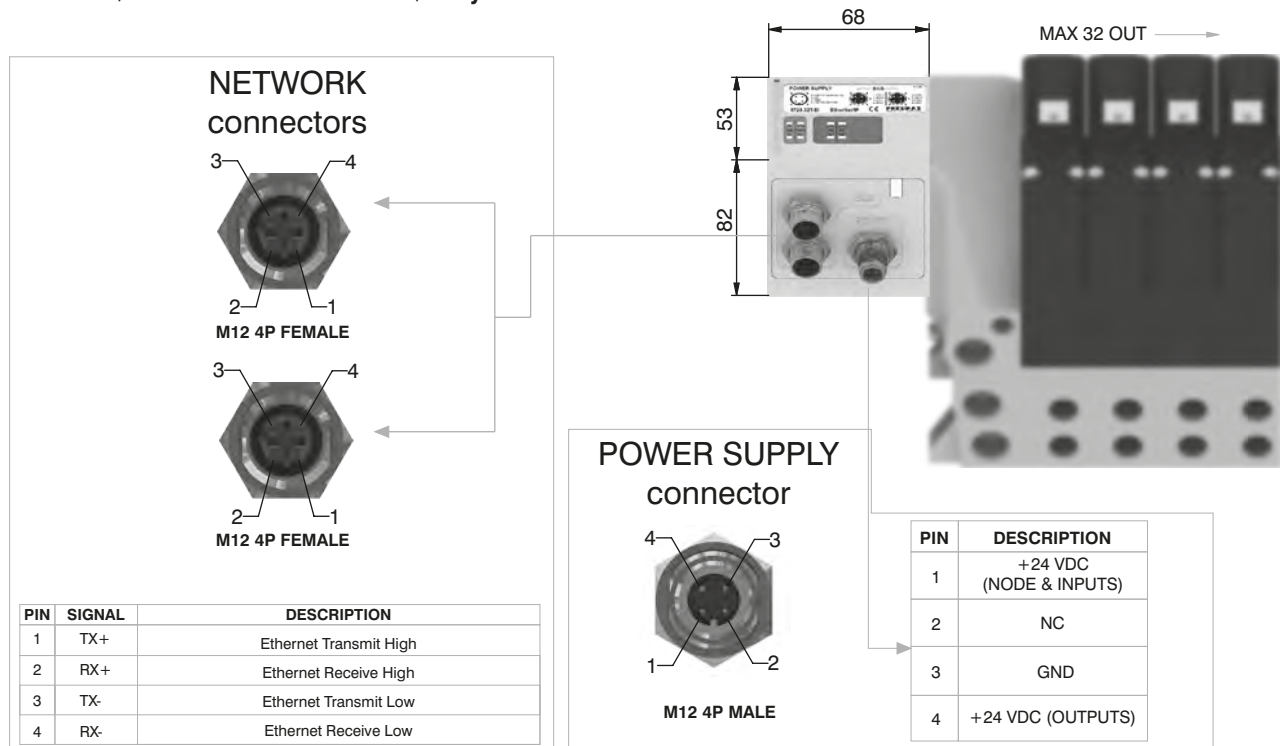

**Technical characteristics**

	Model	5725.32T.EI
	Specifications	The EtherNet/IP Specification
	Case	Reinforced technopolymer
<b>Power supply</b>	Power supply connection	M12 4P male connector (IEC 60947-5-2)
	Power supply voltage	+24 VDC +/- 10%
	Node consumption (without inputs)	400 mA
	Power supply diagnosis	Green LED PWR / Green LED OUT
<b>Outputs</b>	PNP equivalent outputs	+24 VDC +/- 10%
	Maximum current for each output	100 mA
	Maximum output number	32
	Max output simultaneously actuated	32
<b>Network</b>	Network connectors	2 M12 4P female connectors Type D (IEC 61076-2-101)
	Baud rate	100 Mbit/s
	Addresses, possible numbers	As an IP address
	Max nodes in net	As an Ethernet Network
	Maximum distance between 2 nodes	100 m
	Bus diagnosis	1 green and 1 red LED for status + 4 LEDs for link & activity
	Configuration file	Available from our web site: <a href="http://www.pneumaxspa.com">http://www.pneumaxspa.com</a>
	IP protection grade	IP65 when assembled
	Temperature range	From 0° to +50° C

**General :**

Powerlink module is directly integrated on 2700 solenoid valves manifold via a 37 poles connector, normally used for multipolar cable connection.  
2700 series solenoid valves connected to node must be PNP equivalent (final 02 in ordering code).

The node can be easily installed also on solenoid valves manifold already mounted on equipment.

Module can manage up to 32 solenoid valves, and, in the same time, a max number of 8 Input modules 5225.08T or a max number of 8 Input modules 5225.12T.

The Powerlink module, regardless the number of Input module connected, reports to have connected 8 Input modules.

Regardless of the number of Input modules connected, the manageable solenoid valves are 32.

Node power supply is made by a M12 4P male circular connector.

The separation between node 24 VDC Power supply and outputs 24 VDC allows to switch off the outputs maintaining powered the node and inputs, if present.

Connection to Bus Powerlink is possible via 2 M12 4P type D female circular connectors. These two connectors lead the signal to two different communication ports, so they are not connected in parallel.

The node address is assigned during configuration.

**Ordering code**

**5725.32T.PL**

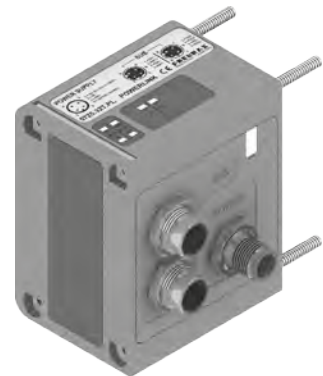

1  
AIR DISTRIBUTION

**Scheme / Overall dimensions and I/O layout :**

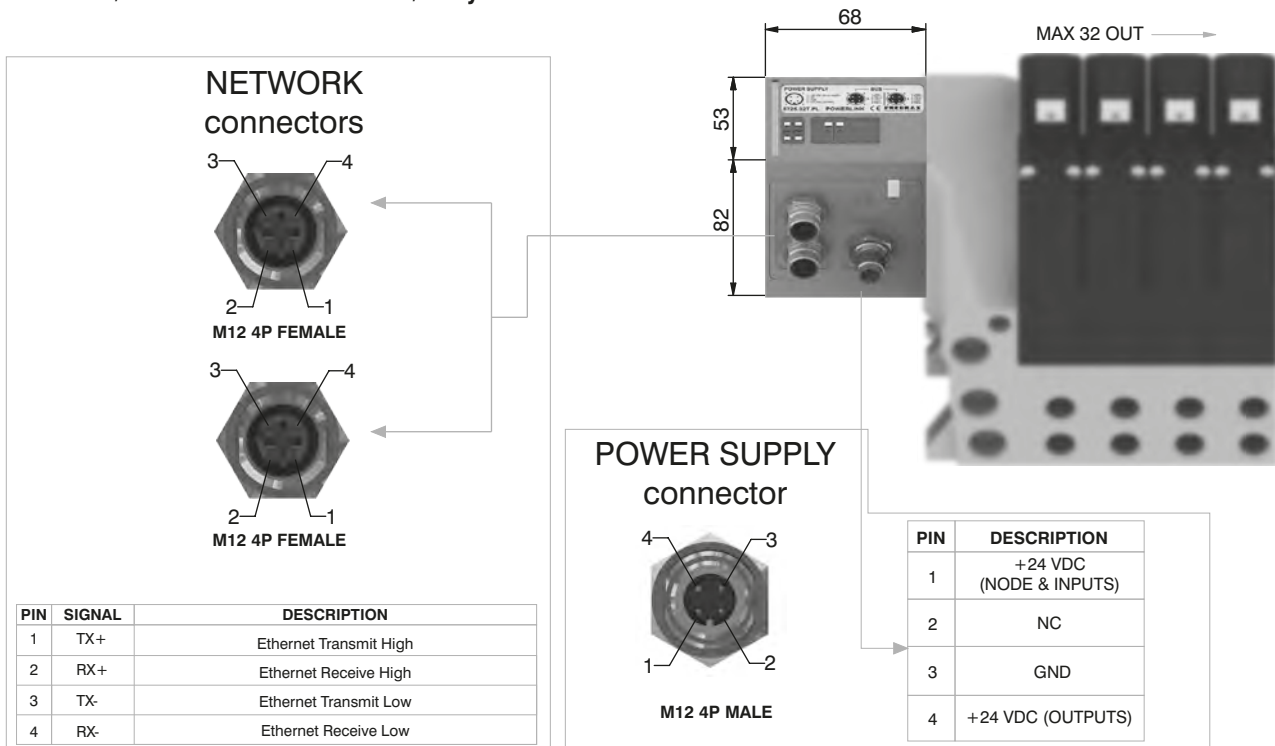

**Technical characteristics**

	Model	5725.32T.PL
	Specifications	Ethernet POWERLINK Communication Profile Specifications
	Case	Reinforced technopolymer
<b>Power supply</b>	Power supply connection	M12 4P male connector (IEC 60947-5-2)
	Power supply voltage	+24 VDC +/- 10%
	Node consumption (without inputs)	400 mA
	Power supply diagnosis	Green LED PWR / Green LED OUT
<b>Outputs</b>	PNP equivalent outputs	+24 VDC +/- 10%
	Maximum current for each output	100 mA
	Maximum output number	32
	Max output simultaneously actuated	32
<b>Network</b>	Network connectors	2 M12 4P female connectors Type D (IEC 61076-2-101)
	Baud rate	100 Mbit/s
	Addresses, possible numbers	239
	Max nodes in net	240
	Maximum distance between 2 nodes	100 m
	Bus diagnosis	1 green and 1 red LED for status + 2 LEDs for link & activity
	Configuration file	Available from our web site: <a href="http://www.pneumaxspa.com">http://www.pneumaxspa.com</a>
	IP protection grade	IP65 when assembled
Temperature range	From 0° to +50° C	

**General :**

Modbus/TCP module is directly integrated on 2700 solenoid valves manifold via a 37 poles connector, normally used for multipolar cable connection.  
 2700 series solenoid valves connected to node must be PNP equivalent (final 02 in ordering code).

The node can be easily installed also on solenoid valves manifold already mounted on equipment.

Module can manage up to 32 solenoid valves, and, in the same time, a max number of 8 Input modules 5225.08T or a max number of 8 Input modules 5225.12T.

The Modbus/TCP module, regardless the number of Input module connected, reports to have connected 8 Input modules.

Regardless of the number of Input modules connected, the manageable solenoid valves are 32.

Node power supply is made by a M12 4P male circular connector.

The separation between node 24 VDC Power supply and outputs 24 VDC allows to switch off the outputs maintaining powered the node and inputs, if present.

Connection to Bus Modbus/TCP is possible via 2 M12 4P type D female circular connectors. These two connectors lead the signal to two different communication ports, so they are not connected in parallel.

The node address is assigned during configuration.

**Ordering code**

**5725.32T.MT**



**Scheme / Overall dimensions and I/O layout :**

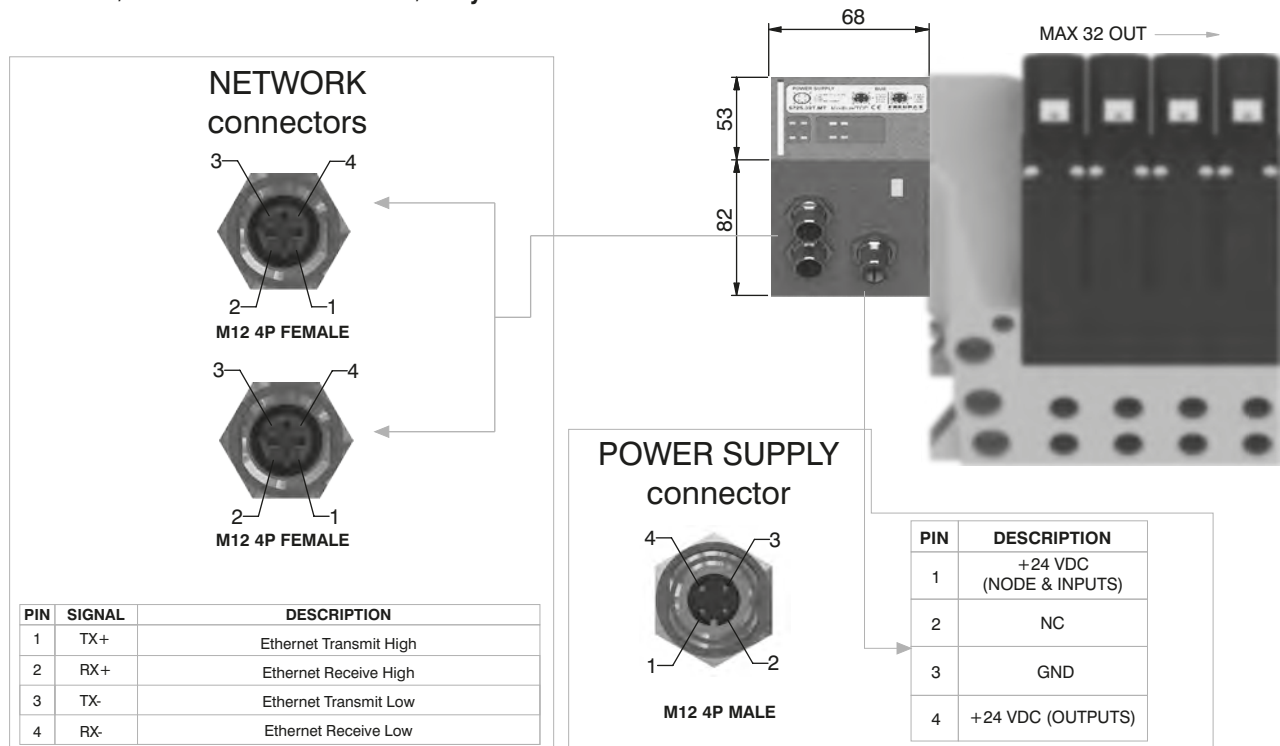

**Technical characteristics**

Model	5725.32T.MT
Specifications	MODBUS Application Protocol Specification V1.1a, June 4, 2004
Case	Reinforced technopolymer
<b>Power supply</b>	Power supply connection M12 4P male connector (IEC 60947-5-2)
	Power supply voltage +24 VDC +/- 10%
	Node consumption (without inputs) 400 mA
	Power supply diagnosis Green LED PWR / Green LED OUT
<b>Outputs</b>	PNP equivalent outputs +24 VDC +/- 10%
	Maximum current for each output 100 mA
	Maximum output number 32
	Max output simultaneously actuated 32
<b>Network</b>	Network connectors 2 M12 4P female connectors Type D (IEC 61076-2-101)
	Baud rate 100 Mbit/s
	Addresses, possible numbers 248
	Max nodes in net 248
	Maximum distance between 2 nodes 100 m
	Bus diagnosis 1 green and 1 red LED for status + 2 LEDs for link & activity
	Configuration file Modbus/TCP nodes don't require configuration file
	IP protection grade IP65 when assembled
	Temperature range From 0° to +50° C



**General :**

Modules have 8 connectors M8 3P female.

The Inputs are PNP equivalent 24 VDC ± 10%.

To each connector it is possible to plug both 2 wires Inputs (switches, magnetic switches pressure switches, etc) or 3 wires Inputs (proximity, photocells, electronic sensors, etc).

The maximum current available for all 8 Inputs is 300 mA.

Each module includes a 300 mA self-mending fuse. If a short circuit or a overcharge (overall current >300mA) occur the safety device acts cutting the 24 VDC power supply to all M8 connectors on the module and switching off the green led PWR. Any other Input module connected to the node will remain powered and will function correctly.

Once the cause of the fault disappears the green LED PWR lights up indicating the ON state and the node will re-start to operate.

The maximum number of Input modules supported is 4 for CANopen®, DeviceNet and EtherCAT®.

The maximum number of Input modules supported is 8 for PROFIBUS DP, PROFINET IO RT/IRT EtherNet/IP and Powerlink.

**Ordering code**

**5225.08T**



**Scheme / Overall dimensions and I/O layout :**

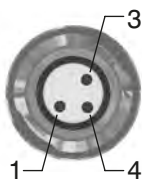
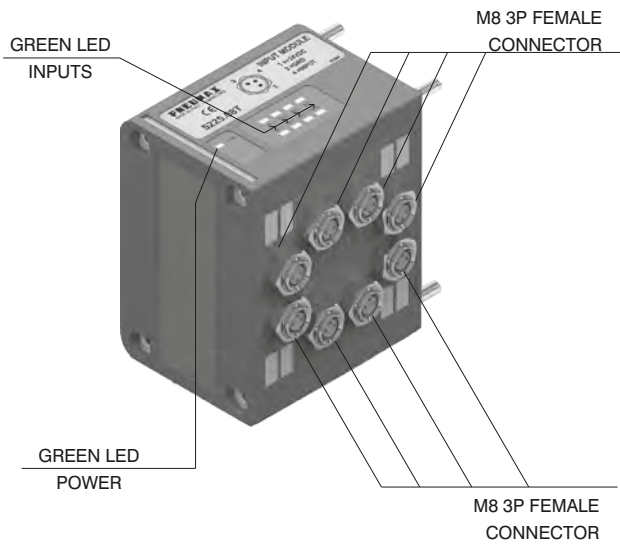

PIN	DESCRIPTION
1	+24 VDC
4	INPUT
3	GND

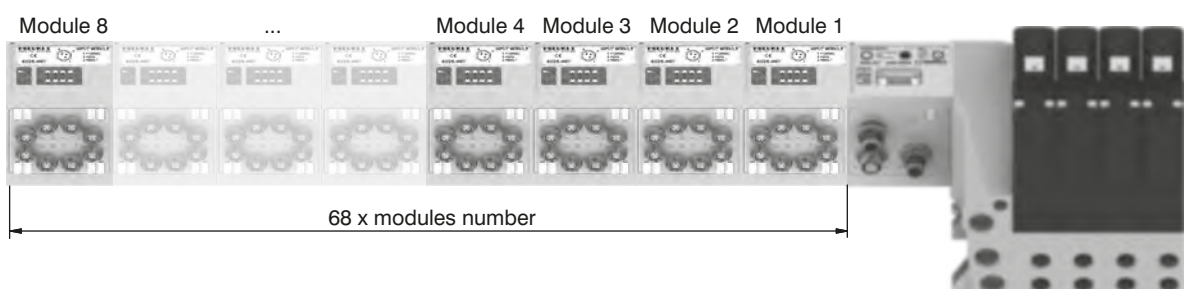
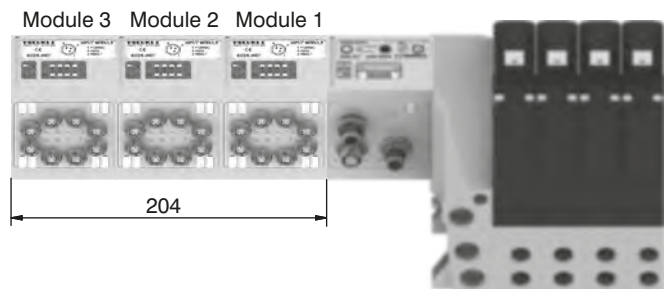
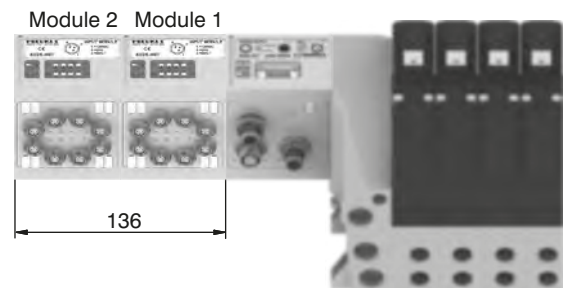
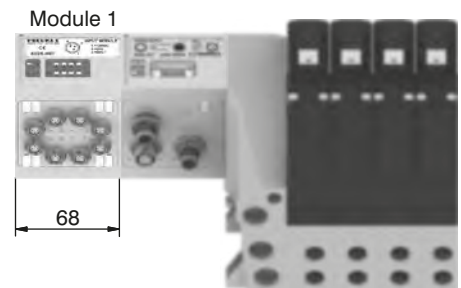

1  
AIR DISTRIBUTION

**General :**

Modules have 4 connectors M12 5P female.

The Inputs are PNP equivalent 24 VDC  $\pm 10\%$ .

To each connector it is possible to plug both 2 wires Inputs (switches, magnetic switches pressure switches, etc) or 3 wires Inputs (proximity, photocells, electronic sensors, etc).

The maximum current available for all 8 Inputs is 300 mA.

Each module includes a 300 mA self-mending fuse. If a short circuit or a overcharge (overall current >300mA) occur the safety device acts cutting the 24 VDC power supply to all M8 connectors on the module and switching off the green led PWR. Any other Input module connected to the node will remain powered and will function correctly.

Once the cause of the fault disappears the green LED PWR lights up indicating the ON state and the node will re-start to operate.

The maximum number of Input modules supported is 4 for CANopen®, DeviceNet and EtherCAT®.

The maximum number of Input modules supported is 8 for PROFIBUS DP, PROFINET IO RT/IRT EtherNet/IP and Powerlink.

**Ordering code**

**5225.12T**

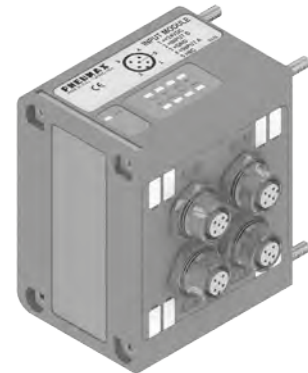

**Scheme / Overall dimensions and I/O layout :**

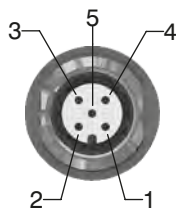
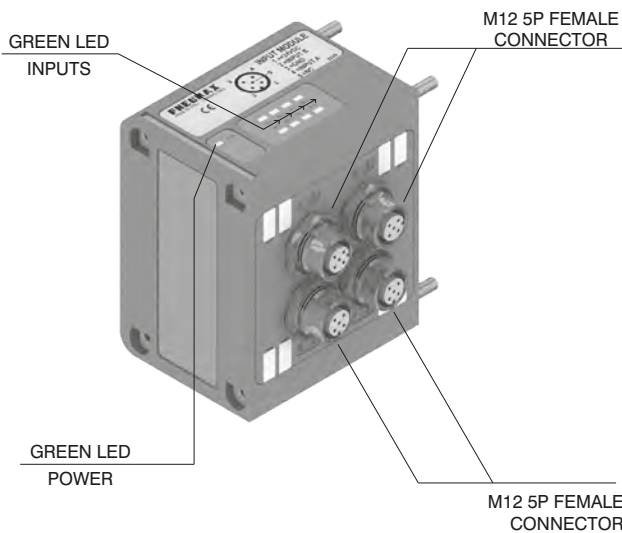

PIN	DESCRIPTION
1	+24 VDC
2	INPUT B
3	GND
4	INPUT A
5	NC

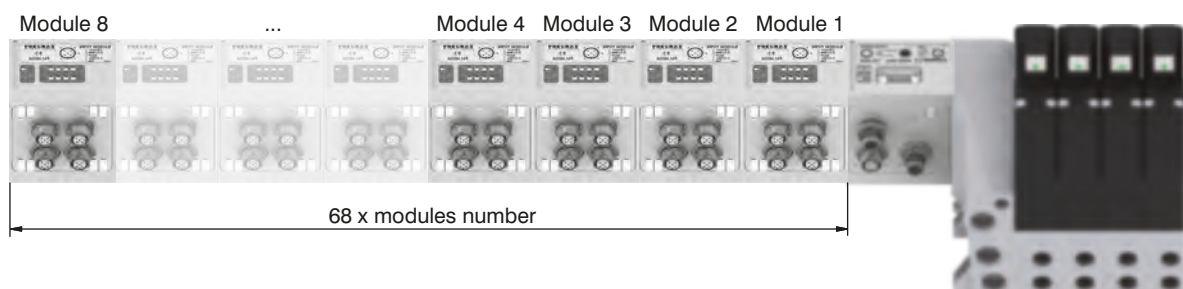
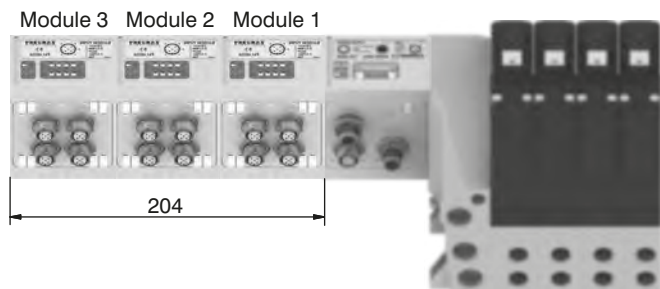
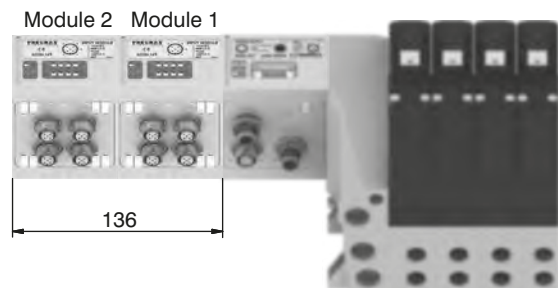
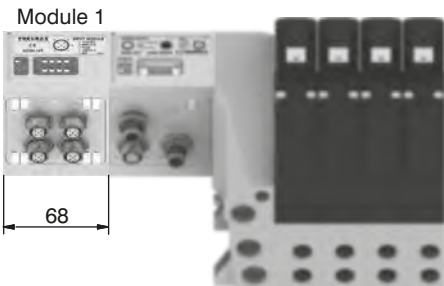



**General :**

This module is fitted with two M8 3 pin female connectors.

With this module is possible to read two analogue inputs (voltage or current).

The inputs are sampled at 12 bit.

For practicality the sampled value is transmitted with 16 bit, of which the four less significant are fixed at zero.

Available models:

- 5225.2T.00T (voltage signal 0 - 10V);
- 5225.2T.01T (voltage signal 0 - 5V);
- 5225.2C.00T (current signal 4 - 20mA);
- 5225.2C.01T (current signal 0 - 20mA).

Each module includes a 300 mA self-mending fuse. Should a short circuit or a overcharge (overall current >300mA) occur the safety device intervenes cutting the 24VDC power supply to all M8 connectors on the module and switching off the green LED PWR. Any other Input module connected to the node will remain powered and will function correctly. Once the cause of the fault is removed the green LED lights up indicating the ON state and the node will re-start to operate.

This module is counted as four 8 digital Inputs modules.

The Maximum number of 2 analogue Inputs modules supported is 1 for CANopen®, DeviceNet, PROFIBUS DP and EtherCAT®.

The Maximum number of 2 analogue Inputs modules supported is 2 for PROFINET IO RT/IRT, EtherNet/IP and Powerlink.

**Ordering code**

5225.2 \_ . \_ T



1  
AIR DISTRIBUTION

**Scheme / Overall dimensions and I/O layout :**

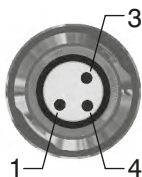
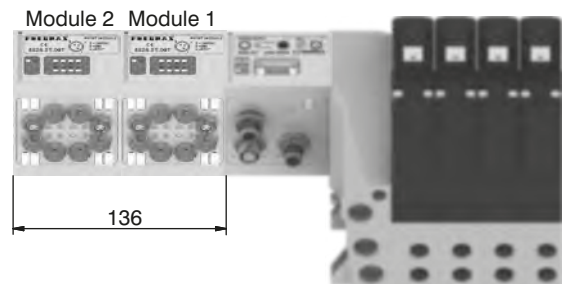
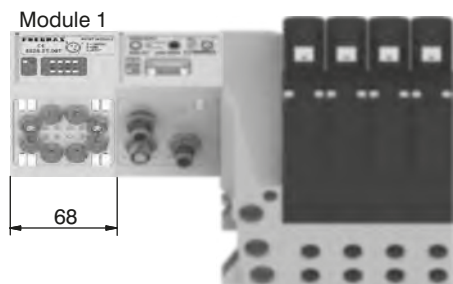
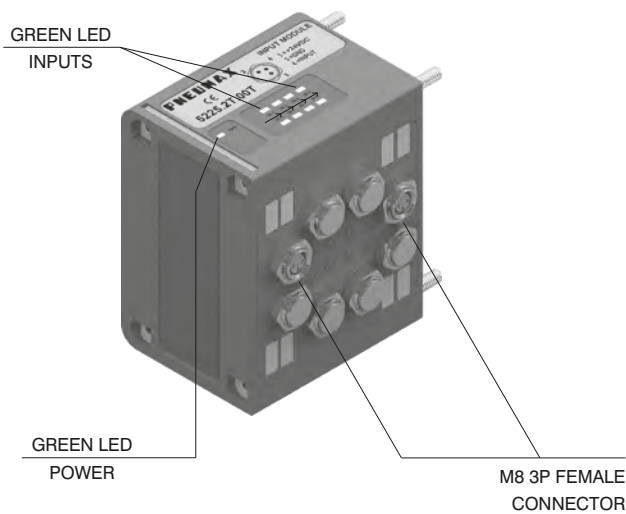

PIN	DESCRIPTION
1	+24 VDC
4	INPUT
3	GND

**General :**

This module is fitted with two M8 3 pin female connectors.

With this module is possible to read two Pt100 probes.

The inputs are sampled at 12 bit.

For practicality the sampled value is transmitted with 16 bit, of which the four less significant are fixed at zero.

It is possible to plug 3-wires probes or 2-wires probes.

The temperature is expressed in tenths of degree.

The temperature range is 0 – 250°C, beyond which the green LED for probe presence doesn't light on.

The module returns a value correspondent to 250°C when the probe is not connected.

Available models:

5225.2P00T (2-wires probes);

5225.2P01T (3-wires probes).

Each module includes a 300 mA self-mending fuse. Should a short circuit or a overcharge (overall current >300mA) occur the safety device intervenes cutting the 24VDC power supply to all M8 connectors on the module and switching off the green LED PWR. Any other Input module connected to the node will remain powered and will function correctly.

Once the cause of the fault is removed the green LED lights up indicating the ON state and the node will re-start to operate.

This module is counted as four 8 digital Inputs modules.

The Maximum number of 2 Pt100 Inputs modules supported is 1 for CANopen®, DeviceNet, PROFIBUS DP and EtherCAT®.

The Maximum number of 2 Pt100 Inputs modules supported is 2 for PROFINET IO RT/IRT, EtherNet/IP and Powerlink.

**Ordering code**

**5225.2P . 0\_T**



1 AIR DISTRIBUTION

**Scheme / Overall dimensions and I/O layout :**

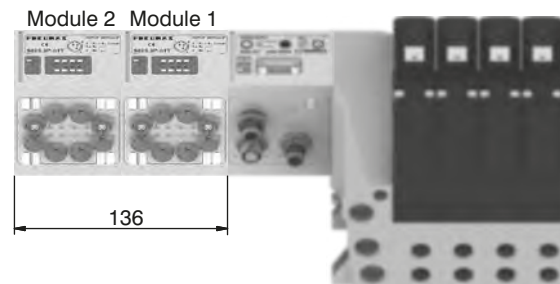
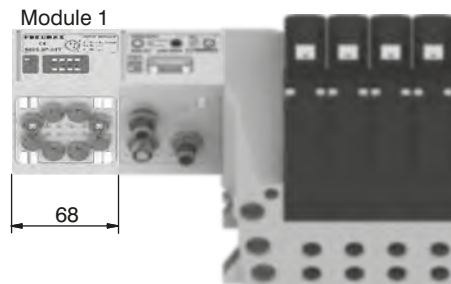
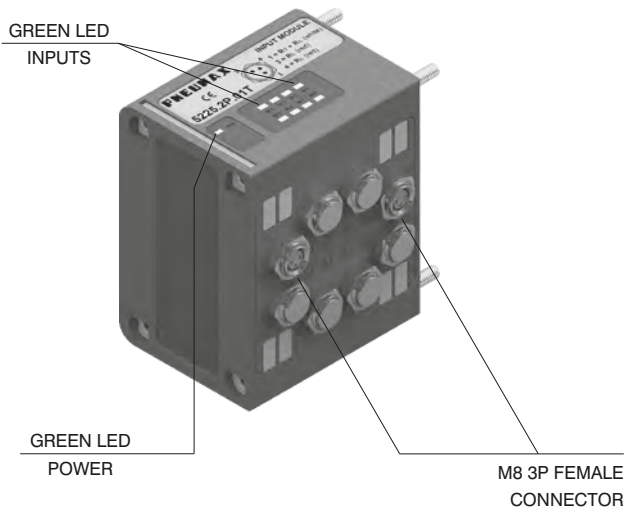

**3 WIRES**

PIN	DESCRIPTION
1	RT (white)
4	RL (red)
3	RL (red)

**2 WIRES**

PIN	DESCRIPTION
1	RT (white)
4	NC
3	RL (red)





**General :**

This module is fitted with two M8 3 pin female connectors.

With this module is possible to read two Pt100 probes.

The inputs are sampled at 12 bit.

For practicality the sampled value is transmitted with 16 bit, of which the four less significant are fixed at zero.

It is possible to plug 3-wires probes or 2-wires probes.

The temperature is expressed in points according to the formula

$$\text{Temperature} = \left( \frac{\text{Points}}{4095} \times 600 \right) - 200$$

The temperature range is -200 to +400°C, beyond which the green LED for probe presence doesn't light on.

The module returns a value correspondent to 400°C when the probe is not connected.

Available models:

5225.2P:10T (2-wires probes);

5225.2P:11T (3-wires probes).

Each module includes a 300 mA self-mending fuse. Should a short circuit or a overcharge (overall current >300mA) occur the safety device intervenes cutting the 24VDC power supply to all M8 connectors on the module and switching off the green LED PWR. Any other INPUT module connected to the node will remain powered and will function correctly.

Once the cause of the fault is removed the green LED lights up indicating the ON state and the node will re-start to operate.

This module is counted as four 8 digital Inputs modules.

The Maximum number of 2 Pt100 Inputs modules supported is 1 for CANopen®, DeviceNet, PROFIBUS DP and EtherCAT®.

The Maximum number of 2 Pt100 Inputs modules supported is 2 for PROFINET IO RT/IRT, EtherNet/IP and Powerlink.

**Ordering code**

5225.2P . 1\_T



1  
AIR DISTRIBUTION

**Scheme / Overall dimensions and I/O layout :**

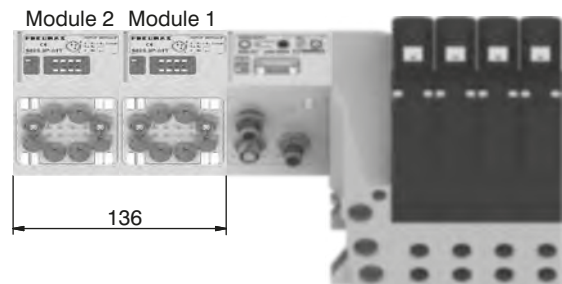
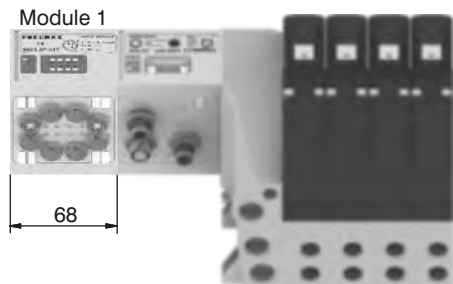
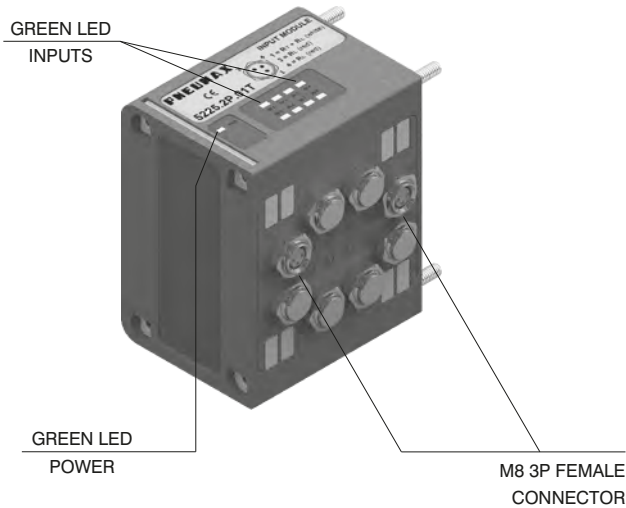

**3 WIRES**

PIN	DESCRIPTION
1	RT (white)
4	RL (red)
3	RL (red)

**2 WIRES**

PIN	DESCRIPTION
1	RT (white)
4	NC
3	RL (red)

Socket for Power Supply  
STRAIGHT CONNECTOR  
M12A 4P FEMALE

Ordering code

5312A.F04.00



POWER SUPPLY connector

Upper view  
Slave connector

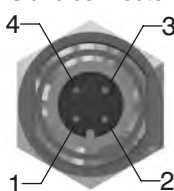

PIN	DESCRIPTION
1	+24 VDC Node
2	
3	0 V
4	+24 VDC Outputs

Socket for Bus CANopen®/DeviceNet  
STRAIGHT CONNECTOR  
M12A 5P FEMALE

Ordering code

5312A.F05.00

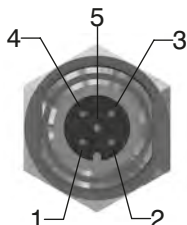

PIN	DESCRIPTION
1	(CAN_SHIELD)
2	(CAN_V+)
3	CAN_GND
4	CAN_H
5	CAN_L

Upper view  
Slave connector

NETWORK connectors

Plug for Bus CANopen®/DeviceNet  
STRAIGHT CONNECTOR  
M12A 5P MALE

Ordering code

5312A.M05.00

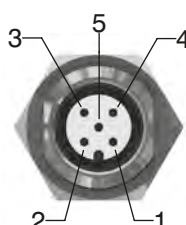

Plug for Bus EtherCAT®,  
PROFINET IO RT,  
EtherNet/IP and Powerlink  
STRAIGHT CONNECTOR M12D 4P MALE

Ordering code

5312D.M04.00



PIN	SIGNAL	DESCRIPTION
1	TX+	Ethernet Transmit High
2	RX+	Ethernet Receive High
3	TX-	Ethernet Transmit Low
4	RX-	Ethernet Receive Low

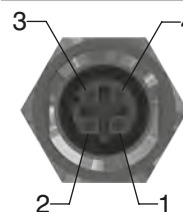

Upper view  
Slave connector

Socket for Bus PROFIBUS DP  
STRAIGHT CONNECTOR  
M12B 5P FEMALE

Ordering code

5312B.F05.00

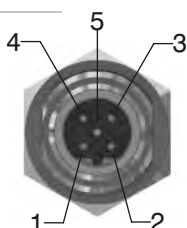

PIN	DESCRIPTION
1	Power Supply
2	A-line
3	DGND
4	B-line
5	SHIELD

Upper view  
Slave connector

Plug for Bus PROFIBUS DP  
STRAIGHT CONNECTOR  
M12B 5P MALE

Ordering code

5312B.M05.00

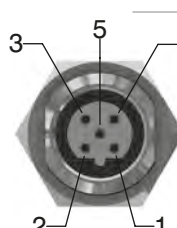

Plug for Input module  
STRAIGHT CONNECTOR  
M8 3P MALE

Ordering code

5308A.M03.00



INPUT connectors

Upper view  
Slave connector

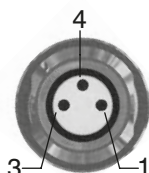

PIN	DESCRIPTION
1	+24 VDC
4	INPUT
3	GND

Plug for Input module  
STRAIGHT CONNECTOR  
M12A 5P MALE

Ordering code

5312A.M05.00



M12 plug

Ordering code

5300.T12



Plugs

M8 plug

Ordering code

5300.T08

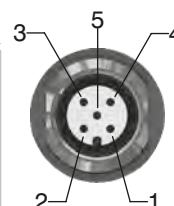

PIN	DESCRIPTION
1	+24 VDC
2	INPUT B
3	GND
4	INPUT A
5	NC



Manifold Layout configuration

**32 OUT VERSION**

- C3 = CANopen® 32OUT
- D3 = DeviceNet 32OUT
- P3 = PROFIBUS 32OUT
- A3 = EtherCAT® 32OUT (5700 Series)
- I3 = EtherNet / IP 32OUT
- N3 = PROFINET IO RT 32OUT
- L3 = Powerlink 32OUT
- M3 = Modbus/TCP 32OUT

**INPUT MODULES**

- A = No module
- D1= 8 M8 digital inputs module
- D2= 8 M12 digital inputs module
- T1= 2 analogue inputs 0-5V module
- T2= 2 analogue inputs 0-10V module
- C1= 2 analogue inputs 0-20mA module
- C2= 2 analogue inputs 4-20mA module
- P1= 2 Pt100 inputs 2 wires module
- P2= 2 Pt100 inputs 3 wires module
- E1= 2 Pt100 inputs 2 wires module extended range
- E2= 2 Pt100 inputs 3 wires module extended range

**RIGHT ENDPLATE**

- U0 = Closed
- U2 = 25 Poles

**I/O MODULE**

- M8 (Requires 25 poles right endplate)



**MODUL CONFIGURATION**

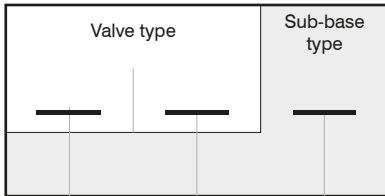

**S.V. POWER**

- E3 = S.V. 2,3W
- E5 = S.V. 1W

**ACCESSORIES CONFIGURATION**



**SUB-BASE TYPE**

- 1 = Base type 1 for Monostable (1 electrical signal occupied)
- 2 = Base type 2 for Bistable (2 electrical signals occupied)

**VALVE TYPE:**

- A = Self-feeding
- E = External feeding

**SHORT CODE FUNCTION / CONNECTION :**

- A= 5/2 SOLENOID - SPRING
- B= 5/2 SOLENOIS - DIFFERENTIAL
- C= 5/2 SOLENOID - SOLENOID
- E= 5/3 CC SOLENOID -SOLENOID
- F= 2x3/2 NC-NC (= 5/3 OC) SOLENOID -SOLENOID
- G= 2x3/2 NO-NO (= 5/3 PC) SOLENOID -SOLENOID
- H= 2x3/2 NC-NO SOLENOID -SOLENOID
- I= 2x3/2 NO-NC SOLENOID -SOLENOID
- T= FREE VALVE SPACE PLUG

**ACCESSORIES**

- X = Diaphragm plug on pipe 1
- Y = Diaphragm plug on pipe 3
- Z = Diaphragm plug on pipe 5
- XY = Diaphragm plug on pipe 1 & 3
- ZX = Diaphragm plug on pipe 5 & 1
- ZY = Diaphragm plug on pipe 5 & 3
- ZXY = Diaphragm plug on pipe 5, 1 & 3

**NOTE:**

While configuring the manifold always be careful that the maximum number of electrical signals available is 32. The use of monostable valve mounted on a base type 2 ( 2 electrical signals occupied ) causes the loss of one electric signal. In this case the monostable valve can be replaced by a bistable valve. The diaphragms plugs are used to intercept the conduits 1,3 & 5 of the base. If it is necessary to interrupt more than one conduit in the same time then put in line the letters which identifies the position (for example : regarding the 3 & 5 conduits, put the Y & Z letters). Should one or more conduits be cut more than one time it is necessary to add the relevant intermediate Supply/Exhaust module.



## Series 2300 - ENOVA®

### General

Technical innovation, rational design, high performance and extremely compact size: these are the main features the ENOVA® series bring to the market.

Each valve comprises all the necessary pneumatic and electrical functions needed to produce a solenoid valve assembly.

There are no limits to the configuration of the solenoid valve island, as full priority has been given to the end user's needs; the addition or removal of modules is a simple operation that can be swiftly and easily achieved.

The management of the electrical signals through the valves is optimized through a patented dedicated connector in each valve.

Electrical connections are made via a twenty-five pin connector, which is capable of controlling up to twenty-two solenoids.

Electrical and pneumatic connections are located on the same module at one end of the assembly.

Serial bus nodes compatible with most common protocols are easily integrated.

Most widely used and known communication protocols, such as PROFIBUS DP, CANopen®, DeviceNet, AS-Interface can be directly integrated with the valve manifold by simply plugging the necessary module onto the electrical connection, maintaining IP65 environmental protection.

The management of inputs has also been foreseen, and can be achieved by adding one or more expansion modules directly to the serial module.

**“Shifting time of pneumatic directional control valves or moving parts, logic devices were measured in accordance to ISO 12238:2001, Pneumatic fluid power-Directional control valves-Measurement of shifting time”**

### Main characteristics

- Clean profile prevents accumulation of dirt
- Compact size: modules of 12.5 mm
- Connections available: 4 , 6 , 8 mm
- IP65 protection grade
- Optimized electrical connection system
- Electrical and pneumatic line connections on one side
- Quick coupling connection system with visual indicator: locked/unlocked
- Freedom of configuration

### Functions

- 5/2 monostable
- 5/2 bistable
- 5/3 closed centres
- 2x3/2 NC/NC (5/3 open centres)
- 2x3/2 NO/NO (5/3 pressured centres)
- 2x3/2 NC/NO
- 2x2/2 NC/NC
- 2x2/2 NO/NO
- 2x2/2 NC/NO

### Construction characteristics

Central body	Reinforced Technopolymer
External casing	Reinforced Technopolymer
Operators	Reinforced Technopolymer
Spool seals	PUR
Spools	Aluminium 2011
Springs	Spring steel with protective coating
Piston seals	Oil resistant nitrile rubber - NBR

### Technical characteristics

Voltage	24 VDC ± 10% PNP (NPN on request)
Pilot consumption	0,9 Watt
Valve working pressure (1-11)	from vacuum to 10 bar max.
Pilot working pressure (12-14)	from 2,5 to 7 bar max.
Operating temperature	-5°C +50°C
Protection degree	IP65
Fluid	Filtered air. No lubrication needed, if applied it shall be continuous

**Attention:** dry air must be used for applications below 0°C"

1  
AIR DISTRIBUTION

**Solenoid - Differential (Monostable)**

Coding: 23E C 52.00.36.V

Operational characteristics	
Fluid	Filtered air. No lubrication needed, if applied it shall be continuous
Working pressure (bar)	From vacuum to 10
Pressure range (bar)	2,5 ÷ 7
Temperature °C	-5 ÷ +50
Flow rate at 6 bar with Δp=1 (NI/min)	700
Response time according to ISO 12238, activation time (ms)	12
Response time according to ISO 12238, deactivation time (ms)	15

Shifting time of pneumatic directional control valves or moving parts, logic devices were measured in accordance to ISO 12238:2001

ELECTRICAL CONTACTS	
0	= STANDARD-only one electric signal
1	= CEB (Bistable Electrical contacts)-(two electrical signals)
ELECTRICAL CONTACTS	
4	= Quick connection for tube Ø4
6	= Quick connection for tube Ø6
8	= Quick connection for tube Ø8
VOLTAGE	
02	= 24 VDC PNP
12	= 24 VDC NPN

SHORT CODE B4  
SHORT CODE B6  
SHORT CODE B8  
SHORT CODE R4 (CEB)  
SHORT CODE R6 (CEB)  
SHORT CODE R8 (CEB)

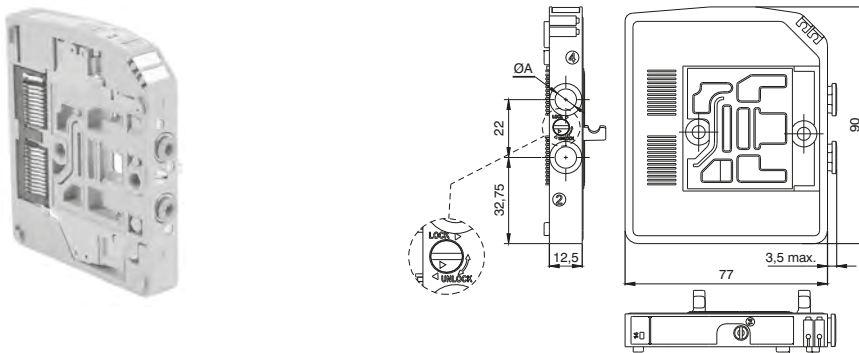

Weight 115 g

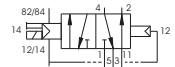

**Solenoid - Spring (Monostable)**

Coding: 23E C 52.00.39.V

Operational characteristics	
Fluid	Filtered air. No lubrication needed, if applied it shall be continuous
Working pressure (bar)	From vacuum to 10
Pressure range (bar)	2,5 ÷ 7
Temperature °C	-5 ÷ +50
Flow rate at 6 bar with Δp=1 (NI/min)	700
Response time according to ISO 12238, activation time (ms)	9
Response time according to ISO 12238, deactivation time (ms)	30

Shifting time of pneumatic directional control valves or moving parts, logic devices were measured in accordance to ISO 12238:2001

ELECTRICAL CONTACTS	
0	= STANDARD-only one electric signal
1	= CEB (Bistable Electrical contacts)-(two electrical signals)
ELECTRICAL CONTACTS	
4	= Quick connection for tube Ø4
6	= Quick connection for tube Ø6
8	= Quick connection for tube Ø8
VOLTAGE	
02	= 24 VDC PNP
12	= 24 VDC NPN

SHORT CODE A4  
SHORT CODE A6  
SHORT CODE A8  
SHORT CODE P4 (CEB)  
SHORT CODE P6 (CEB)  
SHORT CODE P8 (CEB)

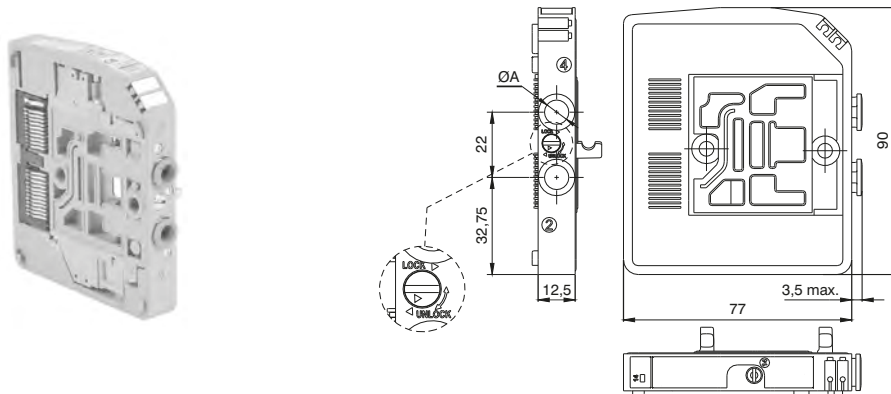

Weight 115 g



1  
AIR DISTRIBUTION

Coding: 230 52.00.35 V

**Solenoid - Solenoid (Bistable)**

**Operational characteristics**

Fluid	Filtered air. No lubrication needed, if applied it shall be continuous
Working pressure (bar)	From vacuum to 10
Pressure range (bar)	2,5 ÷ 7
Temperature °C	-5 ÷ +50
Flow rate at 6 bar with Δp=1 (NI/min)	700
Response time according to ISO 12238, activation time (ms)	7
Response time according to ISO 12238, deactivation time (ms)	7

<b>ELECTRICAL CONTACTS</b>	
4	= Quick connection for tube Ø4
6	= Quick connection for tube Ø6
8	= Quick connection for tube Ø8
<b>VOLTAGE</b>	
02	= 24 VDC PNP
12	= 24 VDC NPN

SHORT CODE C4  
SHORT CODE C6  
SHORT CODE C8

Shifting time of pneumatic directional control valves or moving parts, logic devices were measured in accordance to ISO 12238:2001

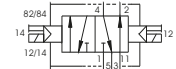
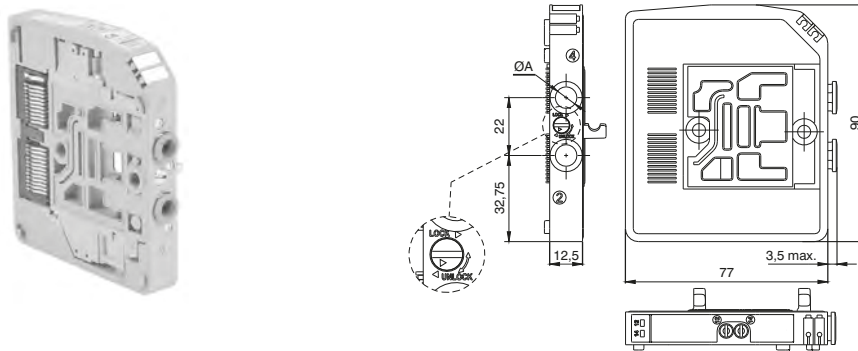

Weight 115 g

**Solenoid - Solenoid (Bistable-Closed centres)**

**Operational characteristics**

Fluid	Filtered air. No lubrication needed, if applied it shall be continuous
Working pressure (bar)	From vacuum to 10
Pressure range (bar)	2,5 ÷ 7
Temperature °C	-5 ÷ +50
Flow rate at 6 bar with Δp=1 (NI/min)	550
Response time according to ISO 12238, activation time (ms)	15
Response time according to ISO 12238, deactivation time (ms)	15

Coding: 230 53.31.35 V

<b>ELECTRICAL CONTACTS</b>	
4	= Quick connection for tube Ø4
6	= Quick connection for tube Ø6
8	= Quick connection for tube Ø8
<b>VOLTAGE</b>	
02	= 24 VDC PNP
12	= 24 VDC NPN

SHORT CODE E4  
SHORT CODE E6  
SHORT CODE E8

Shifting time of pneumatic directional control valves or moving parts, logic devices were measured in accordance to ISO 12238:2001

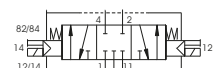
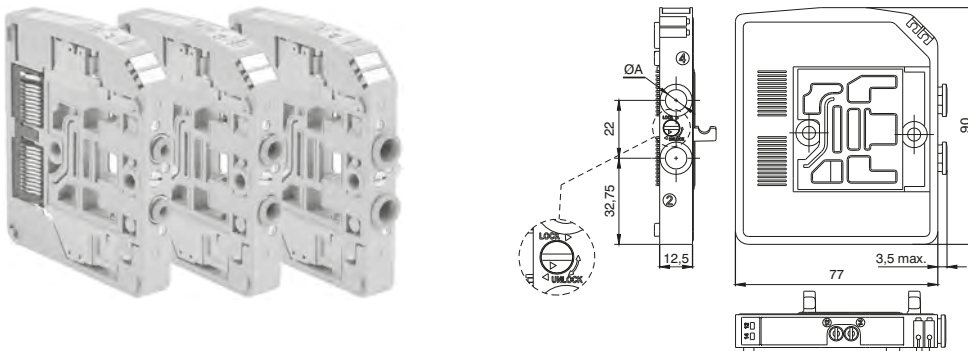

Weight 130 g

1 AIR DISTRIBUTION

**Solenoid - Solenoid 2x3/2 Bistable-N.C.-N.C. (=5/3 Open centres)**

Coding: 230 62.44.35. V

Operational characteristics	
Fluid	Filtered air. No lubrication needed, if applied it shall be continuous
Working pressure (bar)	From vacuum to 10
Pressure range (bar)	2,5 ÷ 7
Temperature °C	-5 ÷ +50
Flow rate at 6 bar with Δp=1 (NI/min)	700
Response time according to ISO 12238, activation time (ms)	9
Response time according to ISO 12238, deactivation time (ms)	30

ELECTRICAL CONTACTS	
4	= Quick connection for tube Ø4
6	= Quick connection for tube Ø6
8	= Quick connection for tube Ø8
VOLTAGE	
02	= 24 VDC PNP
12	= 24 VDC NPN

SHORT CODE F4  
SHORT CODE F6  
SHORT CODE F8

Shifting time of pneumatic directional control valves or moving parts, logic devices were measured in accordance to ISO 12238:2001

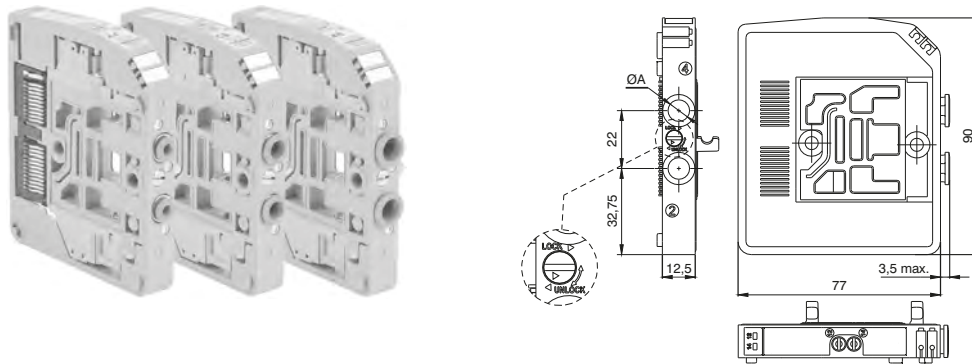

Weight 130 g  
5/3 Open Centres: Use the Solenoid valves with 2x3/2 N.C.-N.C. function  
5/3 Pressured Centres: Use the Solenoid valves with 2x3/2 N.O.-N.O. function

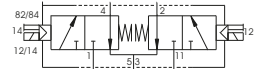

**Solenoid - Solenoid 2x3/2 Bistable-N.C.-N.O.**

Coding: 230 62.45.35. V

Operational characteristics	
Fluid	Filtered air. No lubrication needed, if applied it shall be continuous
Working pressure (bar)	From vacuum to 10
Pressure range (bar)	2,5 ÷ 7
Temperature °C	-5 ÷ +50
Flow rate at 6 bar with Δp=1 (NI/min)	700
Response time according to ISO 12238, activation time (ms)	9
Response time according to ISO 12238, deactivation time (ms)	30

ELECTRICAL CONTACTS	
4	= Quick connection for tube Ø4
6	= Quick connection for tube Ø6
8	= Quick connection for tube Ø8
VOLTAGE	
02	= 24 VDC PNP
12	= 24 VDC NPN

SHORT CODE H4  
SHORT CODE H6  
SHORT CODE H8

Shifting time of pneumatic directional control valves or moving parts, logic devices were measured in accordance to ISO 12238:2001

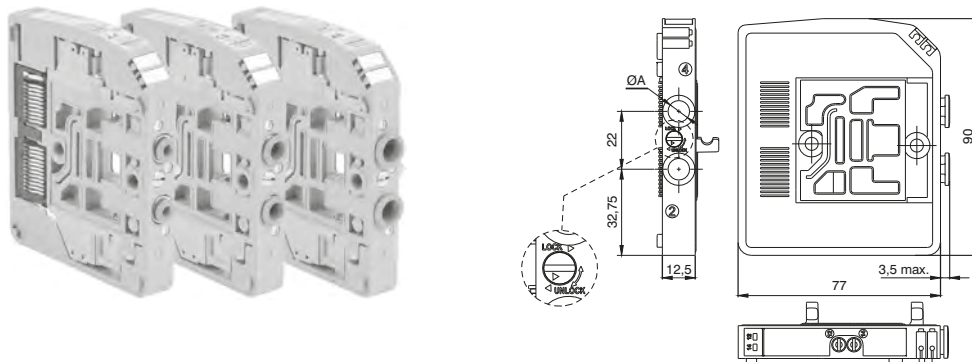

Weight 130 g  
5/3 Open Centres: Use the Solenoid valves with 2x3/2 N.C.-N.C. function  
5/3 Pressured Centres: Use the Solenoid valves with 2x3/2 N.O.-N.O. function

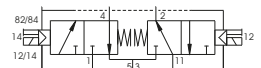

1  
AIR DISTRIBUTION



**Solenoid - Solenoid 2x3/2 Bistable-N.O.-N.O. (=5/3 Pressured centres)**

Coding: 230 62.55.35

Operational characteristics	
Fluid	Filtered air. No lubrication needed, if applied it shall be continuous
Working pressure (bar)	From vacuum to 10
Pressure range (bar)	2,5 ÷ 7
Temperature °C	-5 ÷ +50
Flow rate at 6 bar with Δp=1 (NI/min)	700
Response time according to ISO 12238, activation time (ms)	9
Response time according to ISO 12238, deactivation time (ms)	30

ELECTRICAL CONTACTS	
4	= Quick connection for tube Ø4
6	= Quick connection for tube Ø6
8	= Quick connection for tube Ø8
VOLTAGE	
02	= 24 VDC PNP
12	= 24 VDC NPN

SHORT CODE G4  
SHORT CODE G6  
SHORT CODE G8

Shifting time of pneumatic directional control valves or moving parts, logic devices were measured in accordance to ISO 12238:2001

1 AIR DISTRIBUTION

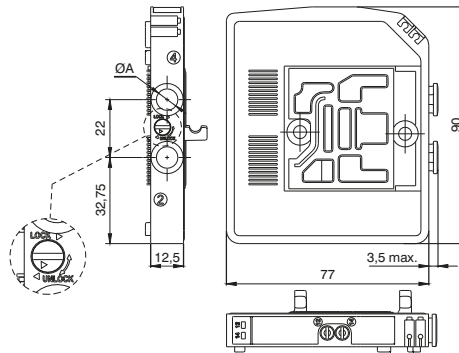
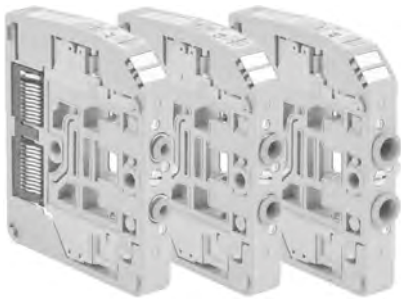

Weight 130 g  
5/3 Open Centres: Use the Solenoid valves with 2x3/2 N.C.-N.C. function  
5/3 Pressured Centres: Use the Solenoid valves with 2x3/2 N.O.-N.O. function

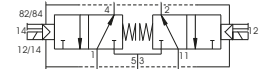

**Solenoid - Solenoid 2x2/2 Bistable-N.C.-N.C.**

Coding: 230 42.44.35

Operational characteristics	
Fluid	Filtered air. No lubrication needed, if applied it shall be continuous
Working pressure (bar)	From vacuum to 10
Pressure range (bar)	2,5 ÷ 7
Temperature °C	-5 ÷ +50
Flow rate at 6 bar with Δp=1 (NI/min)	700
Response time according to ISO 12238, activation time (ms)	9
Response time according to ISO 12238, deactivation time (ms)	30

ELECTRICAL CONTACTS	
4	= Quick connection for tube Ø4
6	= Quick connection for tube Ø6
8	= Quick connection for tube Ø8
VOLTAGE	
02	= 24 VDC PNP
12	= 24 VDC NPN

SHORT CODE L4  
SHORT CODE L6  
SHORT CODE L8

Shifting time of pneumatic directional control valves or moving parts, logic devices were measured in accordance to ISO 12238:2001

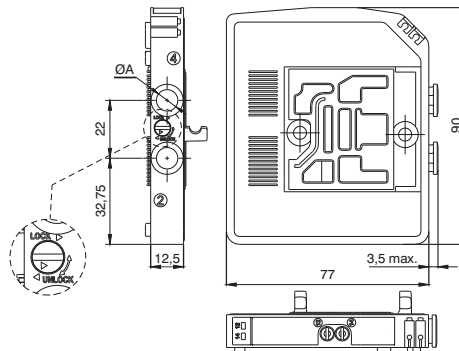

Weight 130 g

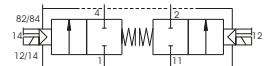



**Solenoid - Solenoid 2x2/2 Bistable-N.C.-N.O.**

Coding: 230 42.45.35. V

Operational characteristics	
Fluid	Filtered air. No lubrication needed, if applied it shall be continuous
Working pressure (bar)	From vacuum to 10
Pressure range (bar)	2,5 ÷ 7
Temperature °C	-5 ÷ +50
Flow rate at 6 bar with Δp=1 (NI/min)	700
Response time according to ISO 12238, activation time (ms)	9
Response time according to ISO 12238, deactivation time (ms)	30

ELECTRICAL CONTACTS	
4	= Quick connection for tube Ø4
6	= Quick connection for tube Ø6
8	= Quick connection for tube Ø8
VOLTAGE	
02	= 24 VDC PNP
12	= 24 VDC NPN

SHORT CODE N4  
SHORT CODE N6  
SHORT CODE N8

Shifting time of pneumatic directional control valves or moving parts, logic devices were measured in accordance to ISO 12238:2001

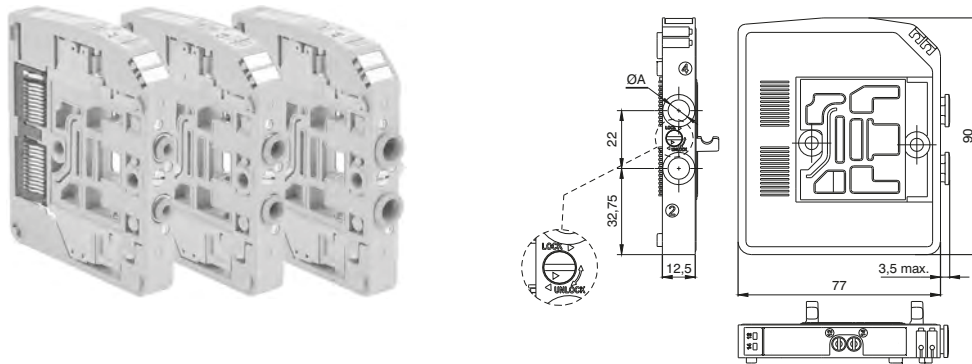

Weight 130 g

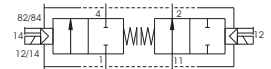

**Solenoid - Solenoid 2x2/2 Bistable-N.O.-N.O.**

Coding: 230 42.55.35. V

Operational characteristics	
Fluid	Filtered air. No lubrication needed, if applied it shall be continuous
Working pressure (bar)	From vacuum to 10
Pressure range (bar)	2,5 ÷ 7
Temperature °C	-5 ÷ +50
Flow rate at 6 bar with Δp=1 (NI/min)	700
Response time according to ISO 12238, activation time (ms)	9
Response time according to ISO 12238, deactivation time (ms)	30

ELECTRICAL CONTACTS	
4	= Quick connection for tube Ø4
6	= Quick connection for tube Ø6
8	= Quick connection for tube Ø8
VOLTAGE	
02	= 24 VDC PNP
12	= 24 VDC NPN

SHORT CODE M4  
SHORT CODE M6  
SHORT CODE M8

Shifting time of pneumatic directional control valves or moving parts, logic devices were measured in accordance to ISO 12238:2001

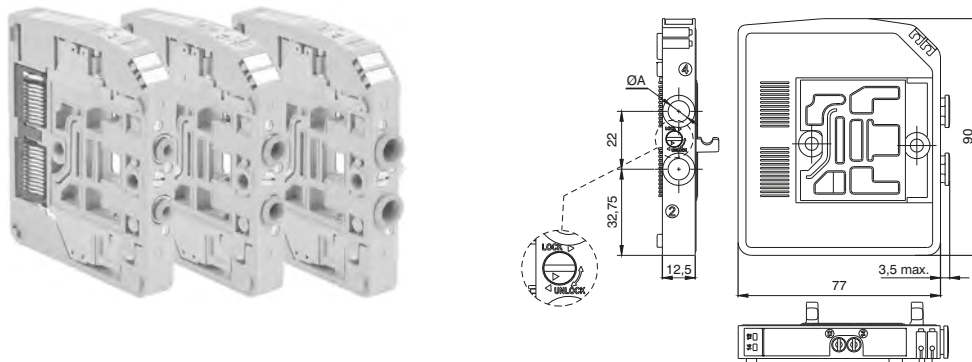

Weight 130 g

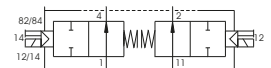

1  
AIR DISTRIBUTION



Left Endplates

Coding: 2311.05C

Operational characteristics	
Fluid	Filtered air. No lubrication needed, if applied it shall be continuous
Working pressure (bar)	From vacuum to 10
Pressure range (bar)	2,5 ÷ 7
Temperature °C	-5 ÷ +50

PORTS	<b>B</b> 05 = 5 ports
	03 = 3 ports
CONNECTIONS	<b>C</b> P = Electrical connection PNP
	N = Electrical connection NPN

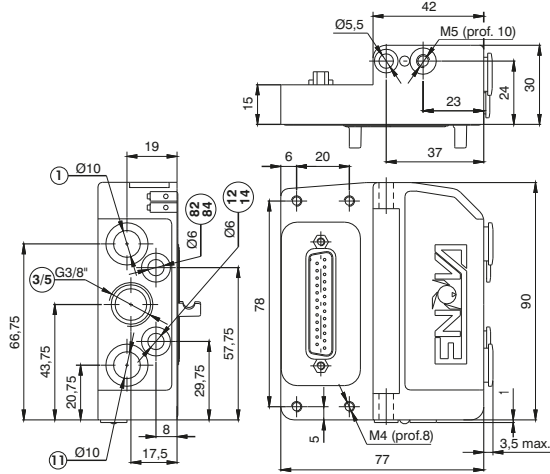

Weight 190 g  
1/11 Conduit (tube ø10): Main Solenoid valve feeding (pressure from vacuum to 10 bar maximum)  
3/5 Conduit (G 3/8"): Main Solenoid valve exhaust

2311.05C

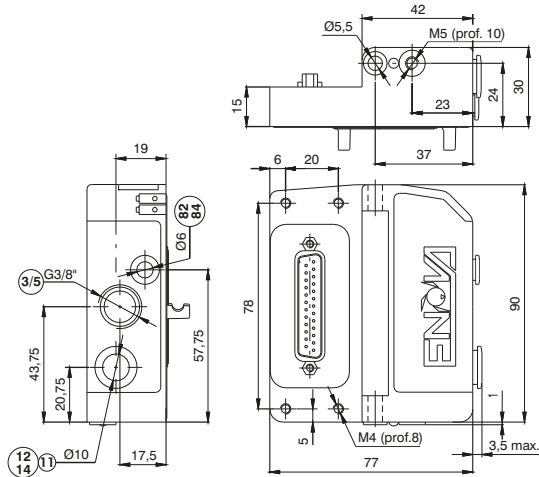

Weight 185 g  
1/11-12/14 Conduit (tube ø10): Main Solenoid valve and pilot feeding (pressure from 2,5bar to 7 bar)  
3/5 Conduit (G 3/8"): Main Solenoid valve exhaust  
82/84 Conduit (tube ø6): Pilot exhaust

2311.03C

Right Endplates closed

Coding: 2312.00

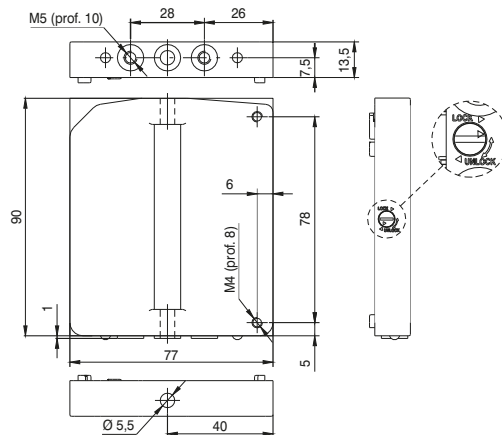

Weight 100 g

1 AIR DISTRIBUTION

► Intermediate Inlet/Exhaust module

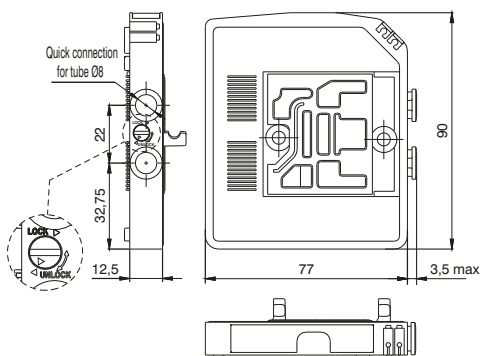

Weight 5 g

Coding: 2308.F

FUNCTION	
F	08 = Exhaust module
	12 = Inlet module
	20 = Inlet-Exhaust module

SHORT CODE J  
SHORT CODE K  
SHORT CODE W

► Through module

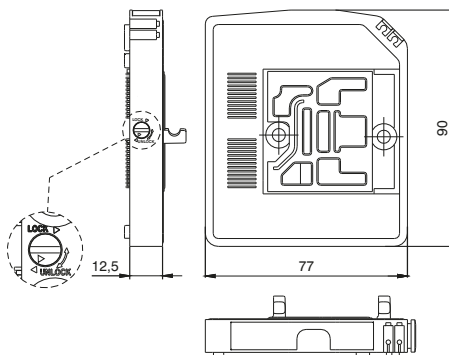

Weight 90 g

Coding: 2300.F

FUNCTION	
F	01 = 1 electric signal module
	02 = 2 electric signals module

SHORT CODE T1  
SHORT CODE T2

► DIN rail adapter

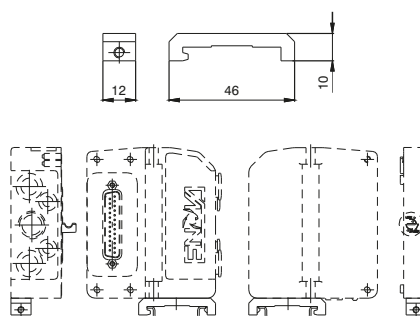

Weight 12 g

Coding: 2300.16

► Fixing brackets

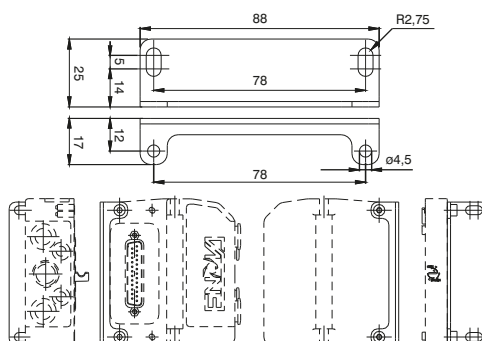

Weight 45 g  
for fixing dimensions see the Left endplates 3 and 5 ports

Coding: 2300.50



▶ Exhaust Diaphragm

Coding: 2317.08

1



Weight 5 g  
SHORT CODE Y

▶ Inlet/Exhaust Diaphragm

Coding: 2317.20



Weight 5 g  
SHORT CODE Z

▶ Inlet Diaphragm

Coding: 2317.12



Weight 5 g  
SHORT CODE X

▶ Cable complete with connector, 25 Poles IP65

Coding: 2300.25.**L**.**C**



	CABLE LENGTH
<b>L</b>	03 = 3 meters
	05 = 5 meters
	10 = 10 meters
	CONNECTOR
<b>C</b>	10 = In line
	90 = 90° Angle



The electrical connection is achieved via a 25 pin connector and can manage up to 22 solenoid pilots.

The management and distribution of the electrical signals between each valve is obtained thanks to a patented electrical connector which receives the signals from the previous module, uses one, two or none depending on the type, and carries forward to the next module the remaining. Bistable valves, 5/3 ; 2X3/2 e 2X2/2 valves which have two solenoid pilots built in, use two signals; the first is directed to the pilot side 14 the second to the pilot side 12.

Mono-stable valves can be fitted with two type of electrical connector: one that uses only one signal (connected to the pilot side 14) and carries forward the remaining and one called CEB (Electrical contact for bistable) which uses two signals, one is needed for the valve the other is not used.

This second solution (CEB) allows the modification of the manifold (replacement of monostable valves with bistable for example) without the need of reconfiguring the PLC outputs layout. On the other hand this solution limits the maximum number of valves to 11 (two signals for each position).

Intermediate supply / exhaust modules are fitted with a dedicated electrical connector which carries forward all electric signals without using any. This allows the use of intermediate modules in any position of the manifold.

Example of manifold samples with the corresponding pin layout.

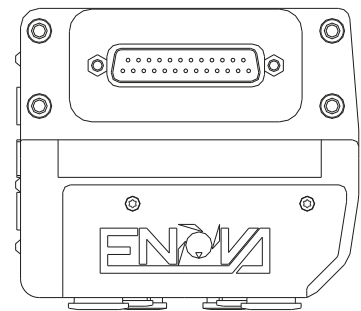
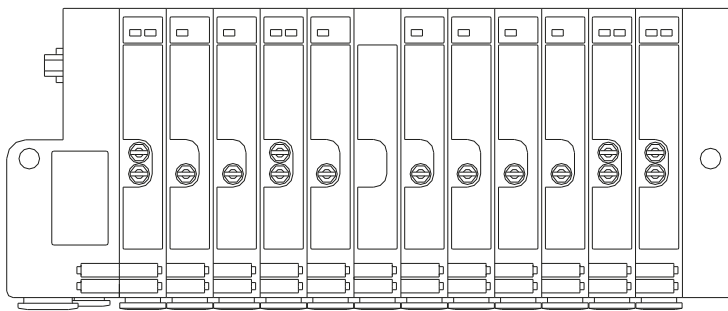

**ELECTRIC CONNECTOR  
SUB-D TYPE - 25 POLES**

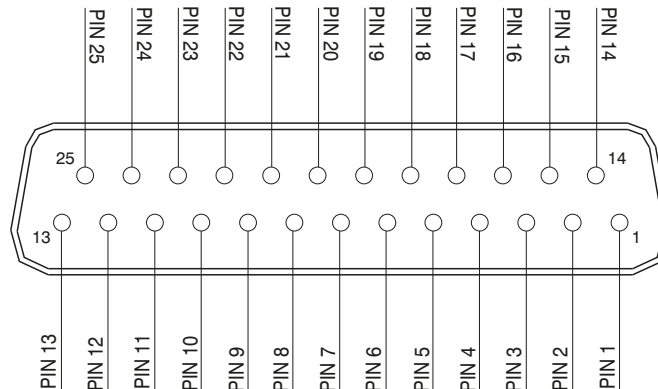

1 - 22 = Solenoid valves signals  
23 - 24 - 25 = Common

**25 PIN Connector correspondence for bistable, 2x3/2, 5/3 and standard monostable valves manifold**

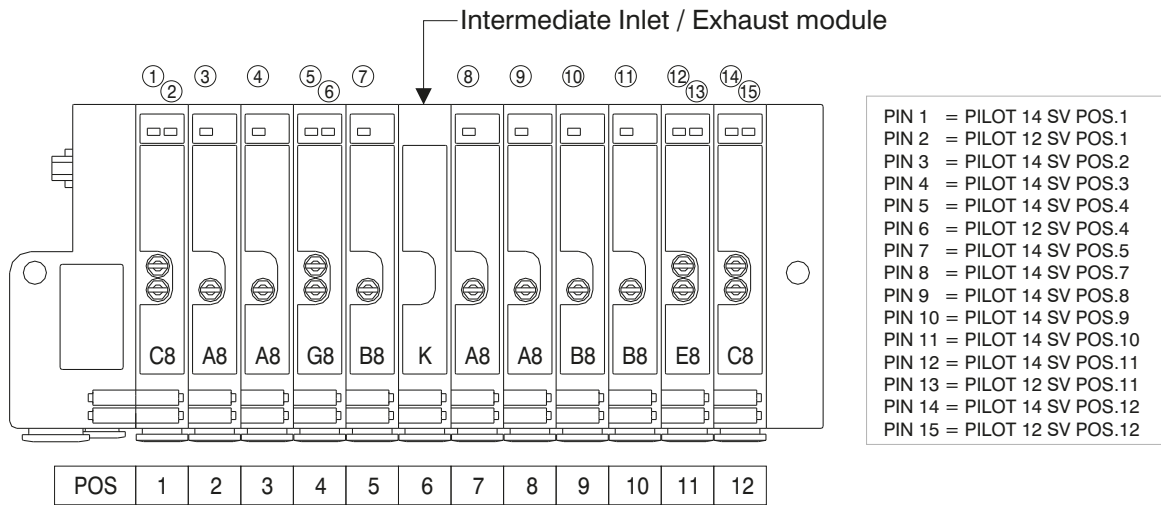

**25 PIN Connector correspondence for bistable, 2x3/2, 5/3 manifold and CEB monostable valves (electrical contact for bistable)**

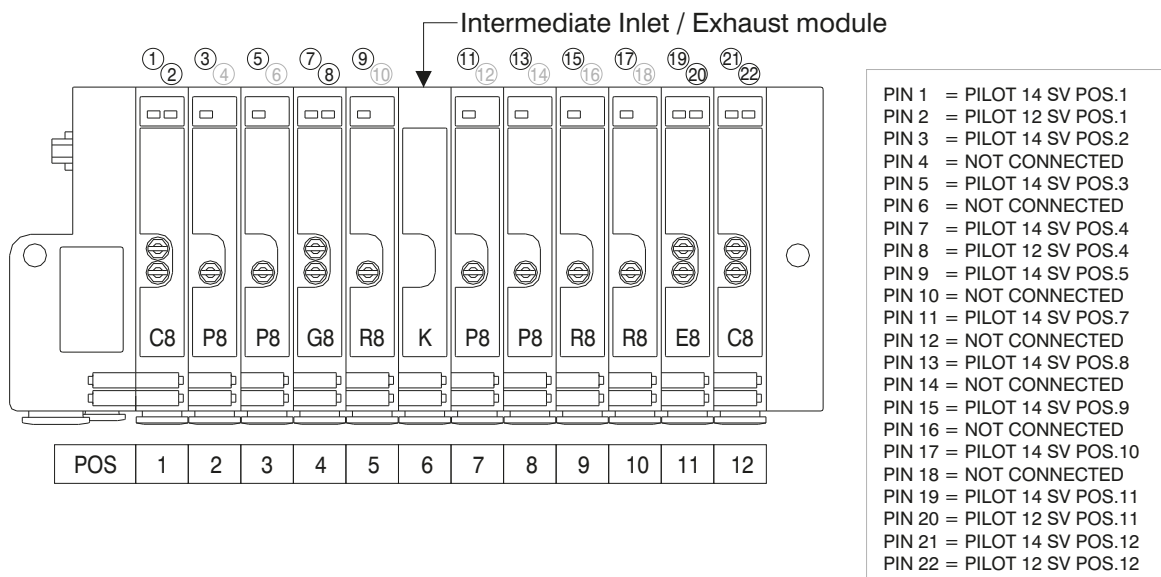

**25 PIN Connector correspondence for manifold for 22 position manifold with standard monostable valves**

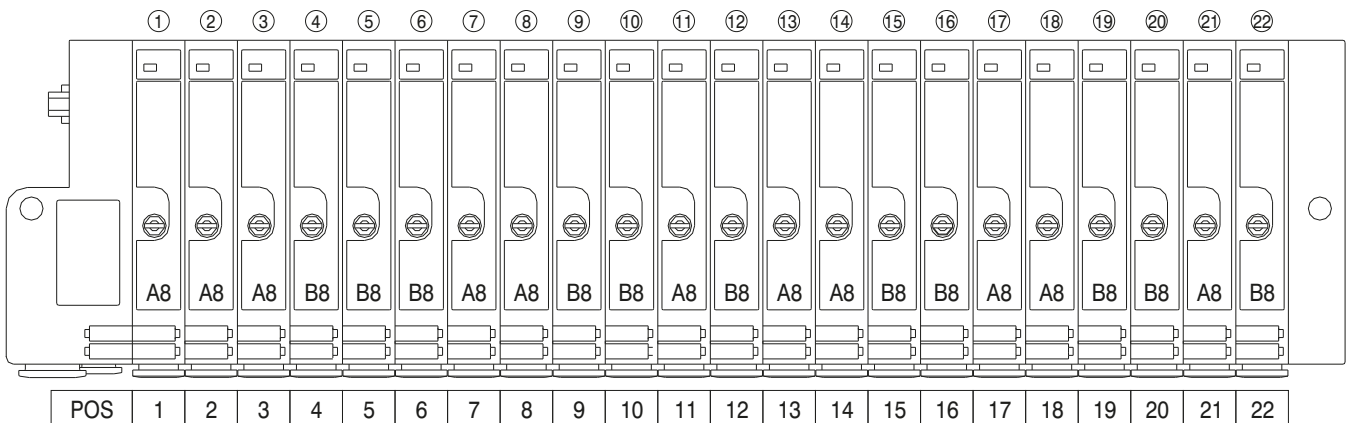

1 AIR DISTRIBUTION

Mounting

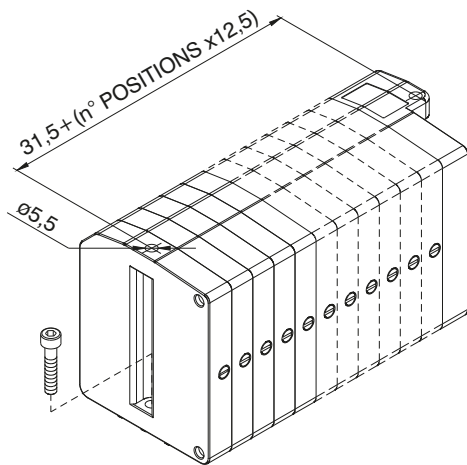

From the top

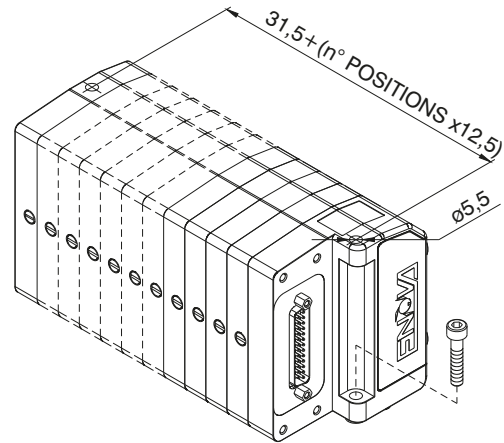

From the bottom

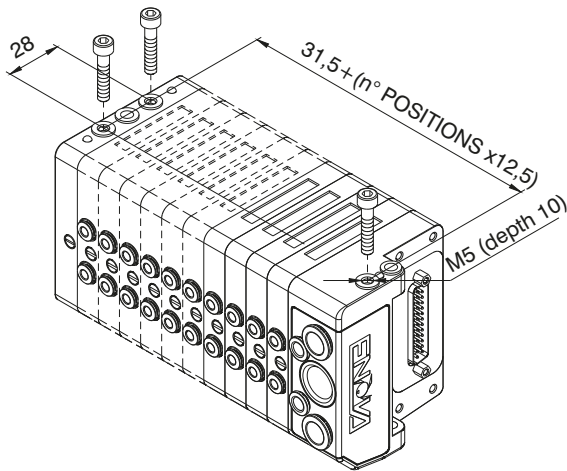

On DIN rail

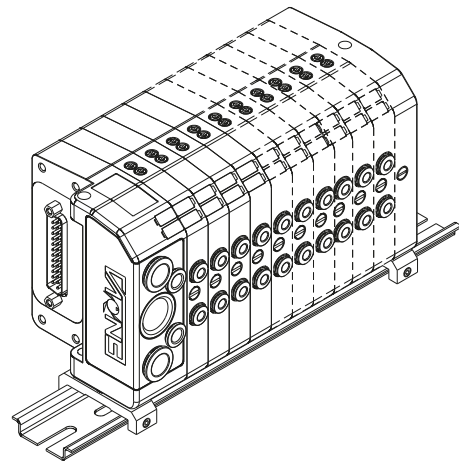

90° Bracket

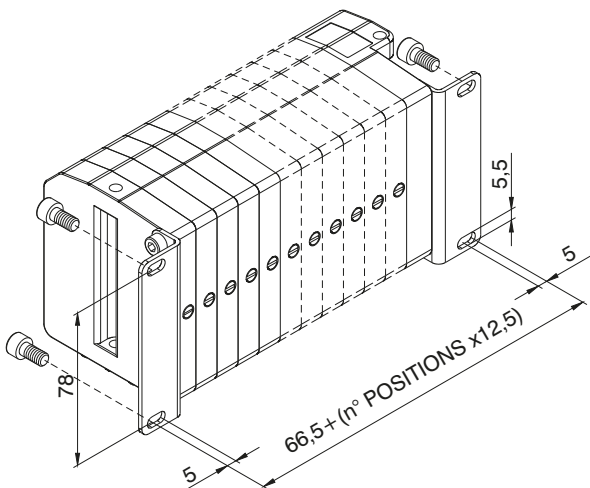

Maximum envelop size based on the number of positions

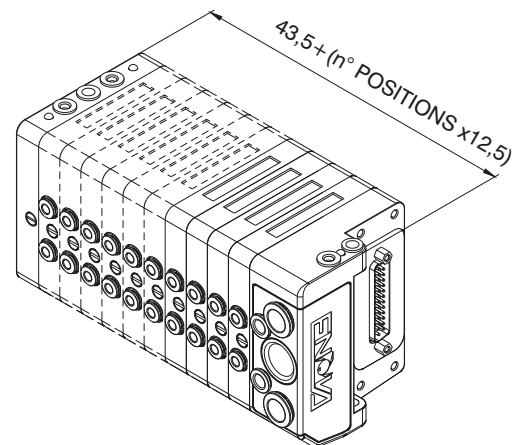

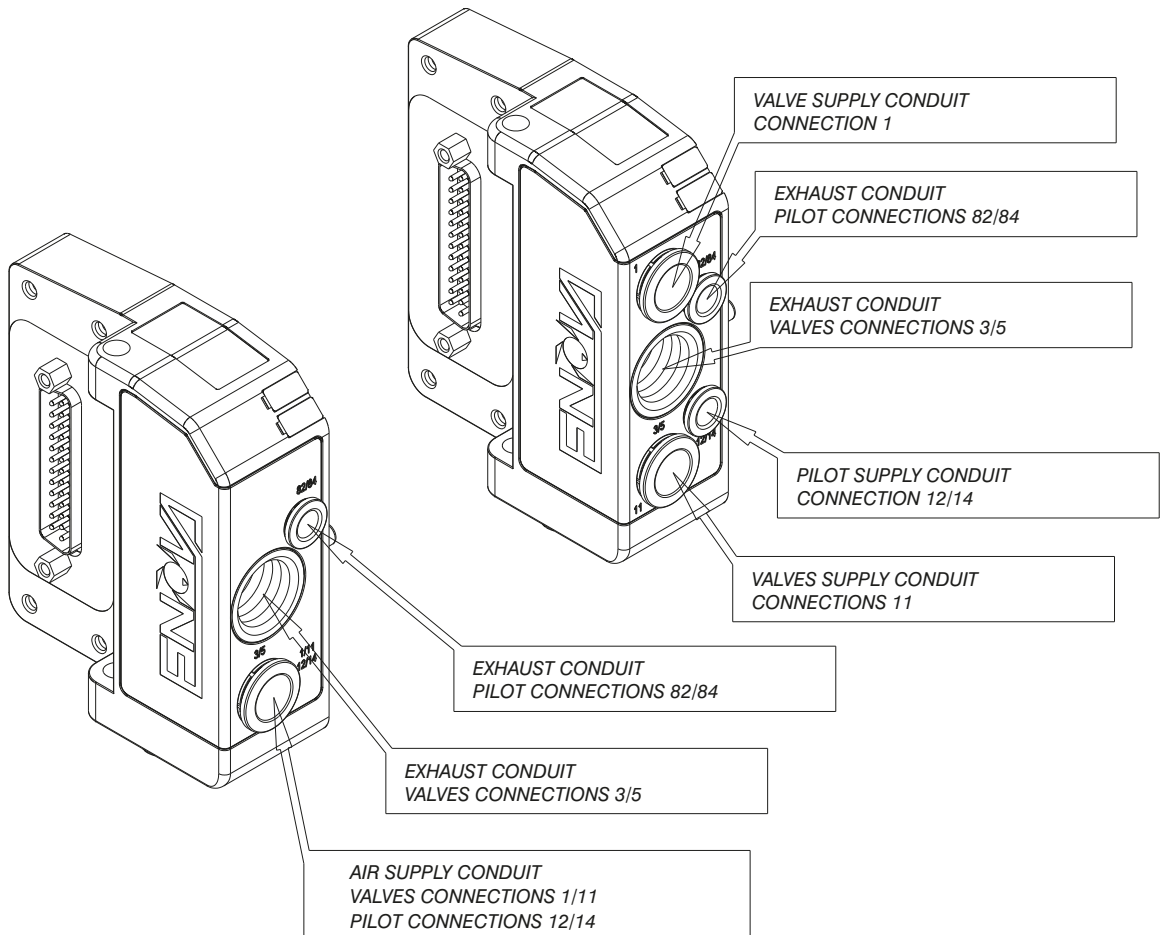
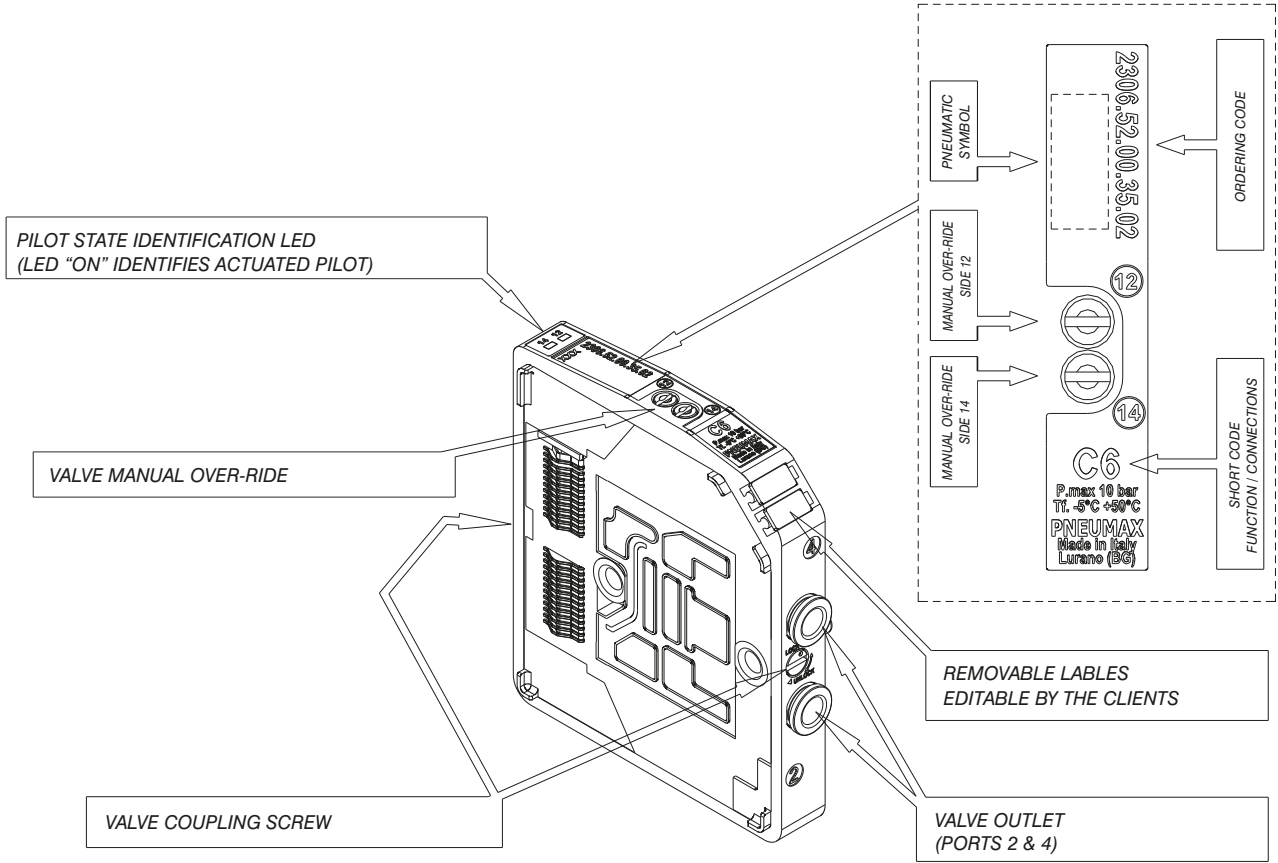



Manual over-ride function

Unstable function

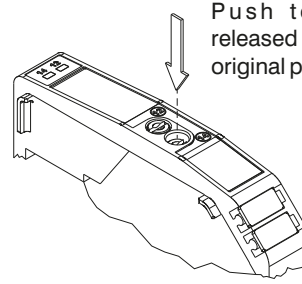
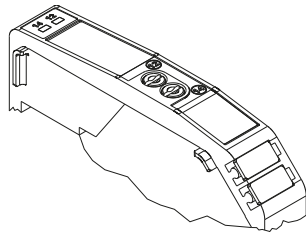

Bistable function

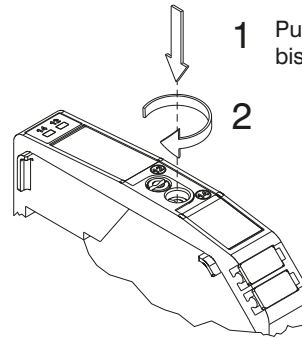
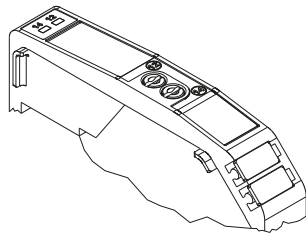

NOTE: It is strongly suggested to replace the original position after using

1  
AIR DISTRIBUTION

Manifold assembly

The assembly procedure should start from the end-plate which should be positioned on a flat surface. Add the requested modules by simply rotating by 180° the fastening pins by means of a 1x5.5 flat screw driver. The last module to be assembled shall be the inlet module

Fastening pins rotation direction:

- To lock: rotate anticlockwise (in the direction of the LOCK print on the case)
- To unlock: rotate clockwise (in the direction of the UNLOCK print on the case)

The same procedure shall be used to add or remove any module.

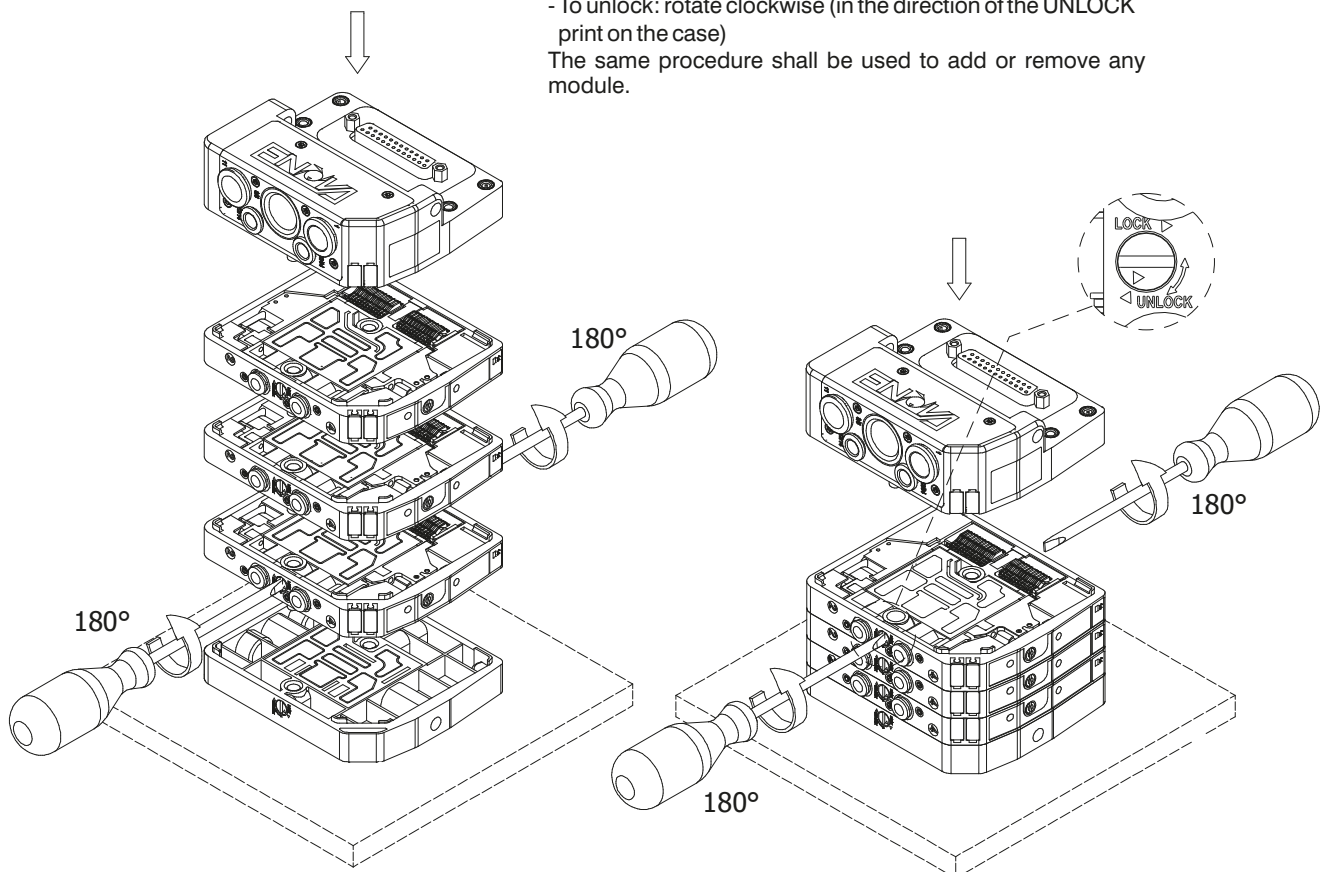

Manifold Lay-Out configuration

1  
AIR DISTRIBUTION

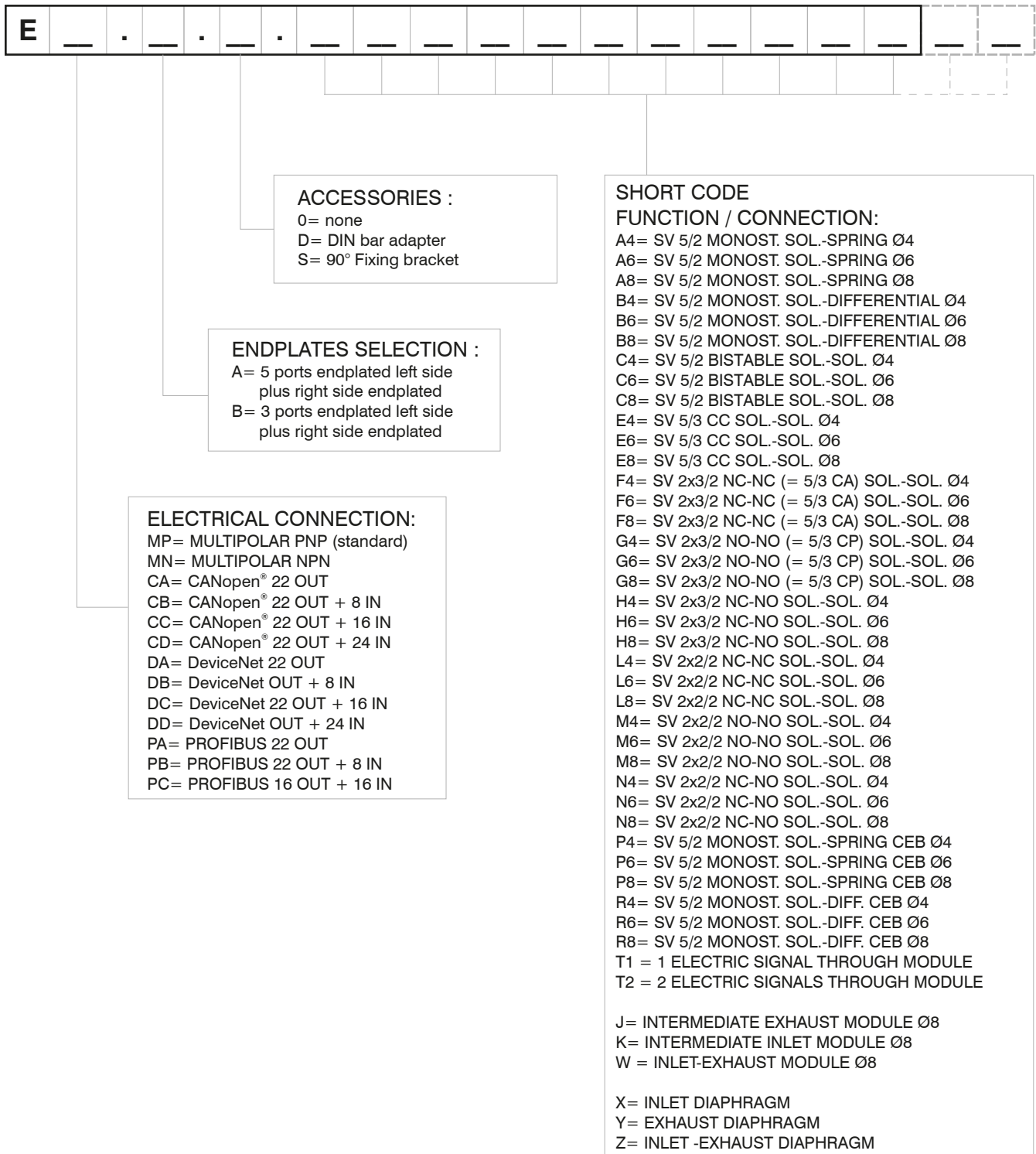

**NOTE:**

While configuring the manifold always bear in mind that the maximum number of electrical signals available is 22.

**N.B.** CEB = Electrical connector for bistable valves ( uses two electric signals)

Intermediate supply / exhaust modules require the same space as a valve but do not use any electric signals (as the electric connector carries forward all signals received from the module immediately before).

The separation diaphragms are positioned between two modules and replace the standard seal therefore do not increase the dimension of the assembly. When using a separation diaphragm of any type, it is necessary to add, in any position between diaphragm and the manifold and plate, an extra air supply / exhaust module depending on the type of diaphragm used.



**General:**

CANopen® module is directly integrated on Enova solenoid valves manifold via a 25 poles connector, normally used for multipolar cable connection.

Enova solenoid valves connected to node must be PNP equivalent (final 02 in ordering code).

The node can be easily installed also on solenoid valves manifold already mounted on equipment.

Module can manage up to 22 solenoid valves, and, in the same time, a max number of 3 Input modules 5200.08.

CANopen® module recognizes automatically the presence of the Input modules on power on.

Regardless of the number of Input modules connected, the managable solenoid valves are 22.

Node power supply is made by a M12 4P male circular connector.

The separation between node 24 VDC Power supply and outputs 24 VDC allows to switch off the outputs maintaining powered the node and inputs, if present.

Connection to Bus CANopen® is possible via 2 M12 5P male - female circular connectors; these two are connected in parallel and according to CiA Draft Standard Proposal 301 V 4.10 (15 August 2006).

Transmission speed can be set by 3 dip-switches.

The node address can be set by 6 dip-switches using BCD numeration.

The module includes an internal terminating resistance that can be activated by a dip-switch.

**Ordering code**

**5523.22**



1  
AIR DISTRIBUTION

**Scheme / Overall dimensions and I/O layout :**

**POWER SUPPLY connector**

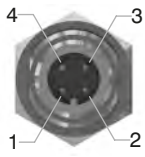

PIN	DESCRIPTION
1	+24 VDC (NODE & INPUTS)
2	NC
3	GND
4	+24 VDC (OUTPUTS)

**NETWORK connectors**

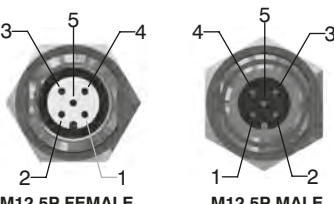

PIN	SIGNAL	DESCRIPTION
1	CAN_SHLD	Optional CAN Shield
2	CAN_V+	Optional CAN external positive supply (Dedicated for supply of transceiver and Optocouplers, if galvanic isolation of the bus node applies)
3	CAN_GND	Ground / 0V / V-
4	CAN_H	CAN_H bus line (dominant high)
5	CAN_L	CAN_L bus line (dominant low)

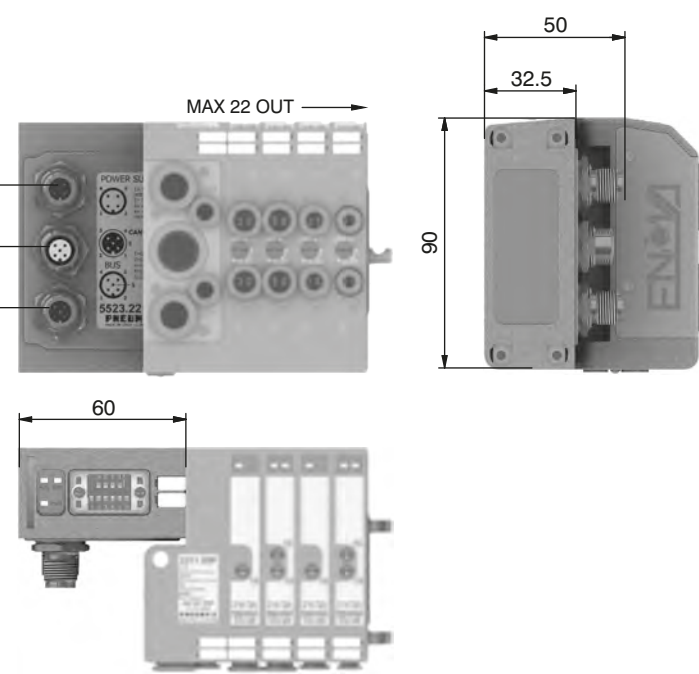

MAX 22 OUT

Dimensions: 50 (width), 32.5 (depth), 60 (height), 90 (total height)

**Technical characteristics**

	Model	5523.22
	Specifications	CiA Draft Standard Proposal 301 V 4.10 (15 August 2006)
	Case	Reinforced technopolymer
<b>Power supply</b>	Power supply connection	M12 4P male connector (IEC 60947-5-2)
	Power supply voltage	+24 VDC +/- 10%
	Node consumption (without inputs)	25 mA
	Power supply diagnosis	Green led PWR
<b>Outputs</b>	PNP equivalent outputs	+24 VDC +/- 10%
	Maximum current for output	100 mA
	Maximum output number	22
	Max output simultaneously actuated	22
<b>Network</b>	Network connectors	2 M12 5P connectors male-female (IEC 60947-5-2)
	Baud rate	10 - 20 - 50 - 125 - 250 - 500 - 800 - 1000 Kbit/s
	Addresses, possibile numbers	From 1 to 63
	Max nodes in net	64 (slave + master)
	Bus maximum recommended length	100 m a 500 Kbit/s
	Bus diagnosis	Green led + Red led
	Configuration file	Available from our web site: <a href="http://www.pneumaxspa.com">http://www.pneumaxspa.com</a>
	IP protection grade	IP65 when assembled
	Temperature range	From -0° to +50° C

**General:**

DeviceNet module is directly integrated on Enova solenoid valves manifold via a 25 poles connector, normally used for multipolar cable connection.  
 Enova solenoid valves connected to node must be PNP equivalent (final 02 in ordering code).  
 The node can be easily installed also on solenoid valves manifold already mounted on equipment.  
 Module can manage up to 22 solenoid valves, and, in the same time, a max number of 3 Input modules 5200.08.  
 DeviceNet module recognizes automatically the presence of the Input modules on power on.  
 Regardless of the number of Input modules connected, the manageable solenoid valves are 22.  
 Node power supply is made by a M12 4P male circular connector.  
 The separation between node 24 VDC Power supply and outputs 24 VDC allows to switch off the outputs maintaining powered the node and inputs, if present.  
 Connection to Bus DeviceNet is possible via 2 M12 5P male - female circular connectors; these two are connected in parallel and according to DeviceNet Specifications Volume I, release 2.0.  
 Transmission speed can be set by 3 dip-switches.  
 The node address can be set by 6 dip-switches using BCD numeration.  
 The module includes an internal terminating resistance that can be activated by a dip-switch.

**Ordering code**

**5423.22**



**Scheme / Overall dimensions and I/O layout :**

**POWER SUPPLY connector**

PIN	DESCRIPTION
1	+24 VDC (NODE & INPUTS)
2	NC
3	GND
4	+24 VDC (OUTPUTS)

**NETWORK connectors**

PIN	SIGNAL	DESCRIPTION
1	CAN_SHLD	Optional CAN Shield
2	CAN_V+	Optional CAN external positive supply (Dedicated for supply of transceiver and Optocouplers, if galvanic isolation of the bus node applies)
3	CAN_GND	Ground / 0V / V-
4	CAN_H	CAN_H bus line (dominant high)
5	CAN_L	CAN_L bus line (dominant low)

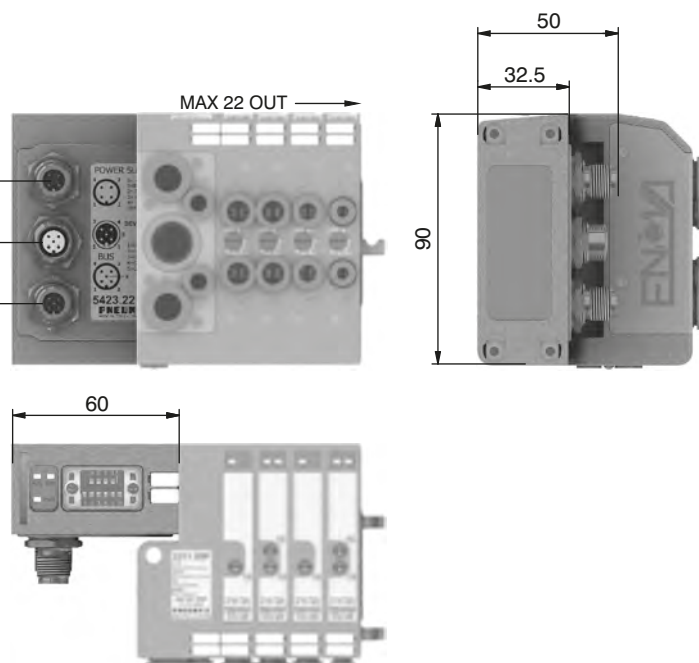

**Technical characteristics**

	Model	5423.22
	Specifications	DeviceNet Specifications Volume I, release 2.0.
	Case	Reinforced technopolymer
<b>Power supply</b>	Power supply connection	M12 4P male connector (IEC 60947-5-2)
	Power supply voltage	+24 VDC +/- 10%
	Node consumption (without inputs)	25 mA
	Power supply diagnosis	Green led PWR
<b>Outputs</b>	PNP equivalent outputs	+24 VDC +/- 10%
	Maximum current for output	100 mA
	Maximum output number	22
	Max output simultaneously actuated	22
<b>Network</b>	Network connectors	2 M12 5P connectors male-female (IEC 60947-5-2)
	Baud rate	125 - 250 - 500 Kbit/s
	Addresses, possible numbers	From 1 to 63
	Max nodes in net	64 (slave + master)
	Bus maximum recommended length	100 m a 500 Kbit/s
	Bus diagnosis	Green led + Red led
	Configuration file	Available from our web site: <a href="http://www.pneumaxspa.com">http://www.pneumaxspa.com</a>
	IP protection grade	IP65 when assembled
	Temperature range	From -0° to +50° C



**General:**

PROFIBUS DP module is directly integrated on Enova solenoid valves manifold via a 25 poles connector, normally used for multipolar cable connection.  
 Enova solenoid valves connected to node must be PNP equivalent (final 02 in ordering code).  
 The node can be easily installed also on solenoid valves manifold already mounted on equipment.  
 Module can manage up to 22 solenoid valves, when is connected 0 or 1 INPUT modules, or 16 if node is fitted with 2 INPUT modules. The max number of INPUT modules 5200.08, is 2.  
 PROFIBUS DP module recognizes automatically the presence of the Input modules on power on.  
 Node power supply is made by a M12 4P male circular connector.  
 The separation between node 24 VDC Power supply and outputs 24 VDC allows to switch off the outputs maintaining powered the node and inputs, if present.  
 Connection to Bus PROFIBUS DP is possible via 2 M12 type B 5P male - female circular connectors; these two are connected in parallel and according to PROFIBUS Interconnection Technology (Version 1.1 : August 2001).  
 The node address can be set using BCD numeration: 4 dip-switches for the units and 4 dip-switches for the tens.  
 The module includes an internal terminating resistance that can be activated by a dip-switch.

**Ordering code**

**5323.22**



1  
AIR DISTRIBUTION

**Scheme / Overall dimensions and I/O layout :**

**POWER SUPPLY connector**

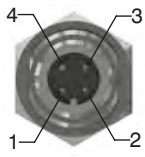

PIN	DESCRIPTION
1	+24 VDC (NODE & INPUTS)
2	NC
3	GND
4	+24 VDC (OUTPUTS)

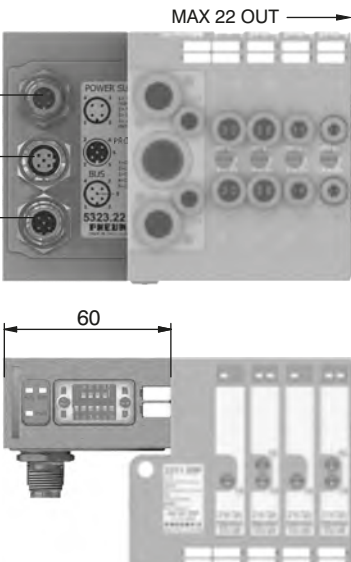

MAX 22 OUT

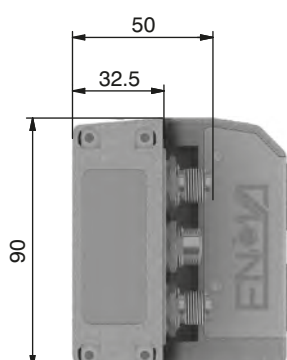

50  
32.5  
90

**NETWORK connectors**

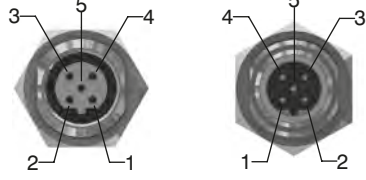

PIN	SIGNAL	DESCRIPTION
1	VP	Power supply plus, (P5V)
2	A-line	Receive / Transmit data -N, A-line
3	DGND	Data Ground (reference potential to VP)
4	B-line	Receive / Transmit data -plus, B-line
5	SHIELD	Shield or PE

**Technical characteristics**

	Model	5323.22
	Specifications	PROFIBUS DP
	Case	Reinforced technopolymer
<b>Power supply</b>	Power supply connection	M12 4P male connector (IEC 60947-5-2)
	Power supply voltage	+24 VDC +/- 10%
	Node consumption (without inputs)	50 mA
	Power supply diagnosis	Green led PWR
<b>Outputs</b>	PNP equivalent outputs	+24 VDC +/- 10%
	Maximum current for output	100 mA
	Maximum output number	22 or 16 if node is fitted with 2 INPUT modules
	Max output simultaneously actuated	22
<b>Network</b>	Network connectors	2 M12 5P connectors male-female (IEC 60947-5-2)
	Baud rate	125 - 250 - 500 Kbit/s
	Addresses, possible numbers	From 1 to 63
	Max nodes in net	64 (slave + master)
	Bus maximum recommended length	100 m a 500 Kbit/s
	Bus diagnosis	Green led + Red led
	Configuration file	Available from our web site: <a href="http://www.pneumaxspa.com">http://www.pneumaxspa.com</a>
	IP protection grade	IP65 when assembled
	Temperature range	From -0° to +50° C

**General:**

Modules have 8 connectors M8 3P female.

The Inputs are PNP equivalent 24 VDC ±10%.

To each connector it is possible to plug both 2 wires Inputs (switches, magnetic switches pressure switches, etc) or 3 wires Inputs (proximity, photocells, electronic sensors, etc).

The maximum current available for all 8 Inputs is 200 mA.

Each module includes a 200 mA resettable fuse. If a short circuit or a overcharge (overall current >200mA) occur the safety device acts cutting the 24 VDC power supply to all M8 connectors on the module and switching off the green led PWR. Any other Input module connected to the node will remain powered and will function correctly.

Once the cause of the fault disappears the green led PWR light up indicating the ON state and the node will re-start to operate.

The Maximum number of Input modules supported is 3 for CANopen and DeviceNet, 2 for PROFIBUS DP.

**Ordering code**

**5200.08**



**Scheme / Overall dimensions and I/O layout :**

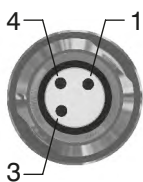
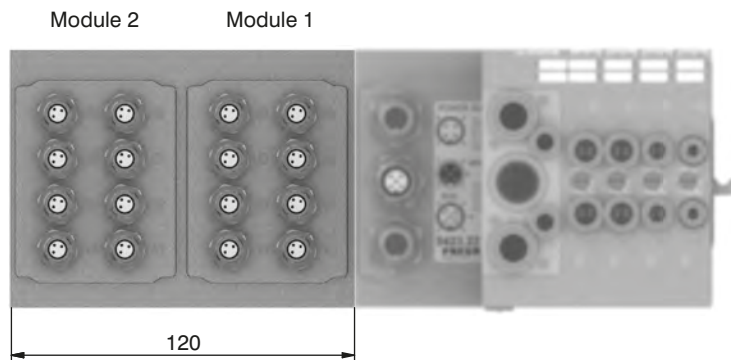
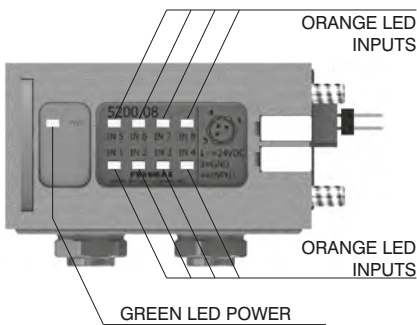
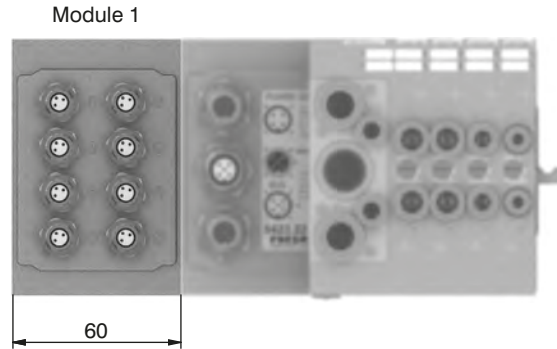
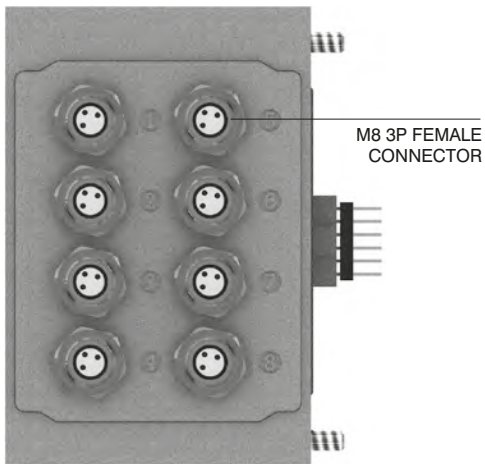

PIN	DESCRIPTION
1	+24 VDC
4	INPUT
3	GND

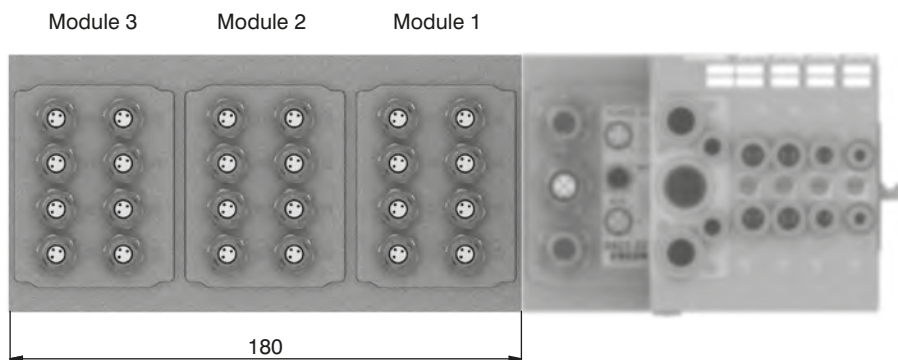

1 AIR DISTRIBUTION



Socket for Power Supply  
STRAIGHT CONNECTOR  
M12A 4P FEMALE

**Ordering code**

**5312A.F04.00**



**POWER SUPPLY connector**

Upper view  
Slave connector

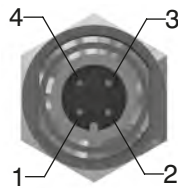

PIN	DESCRIPTION
1	+24 VDC Node
2	
3	0 V
4	+24 VDC Outputs

Socket for Bus CANopen®  
STRAIGHT CONNECTOR  
M12B 5P FEMALE

**Ordering code**

**5312A.F05.00**

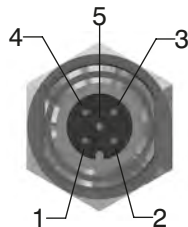

**NETWORK connectors**

PIN	DESCRIPTION
1	(CAN_SHIELD)
2	(CAN_V+)
3	CAN_GND
4	CAN_H
5	CAN_L

Upper view  
Slave connector

Plug for Bus CANopen®  
STRAIGHT CONNECTOR  
M12A 5P MALE

**Ordering code**

**5312A.M05.00**

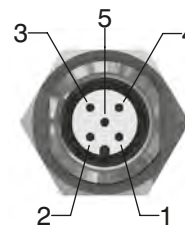

Socket for Bus PROFIBUS  
STRAIGHT CONNECTOR  
M12B 5P FEMALE

**Ordering code**

**5312B.F05.00**

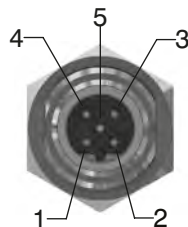

Upper view  
Slave connector

PIN	DESCRIPTION
1	Power Supply
2	A-line
3	DGND
4	B-line
5	SHIELD

Plug for Bus PROFIBUS  
STRAIGHT CONNECTOR  
M12B 5P MALE

**Ordering code**

**5312B.M05.00**

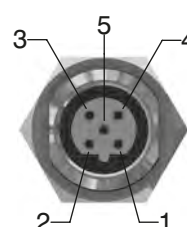

Plug for Input module  
STRAIGHT CONNECTOR  
M8 3P MALE

**Ordering code**

**5308A.M03.00**



**INPUT connectors**

Upper view  
Slave connector

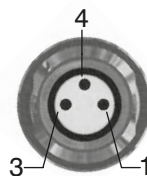

PIN	DESCRIPTION
1	+24 VDC
4	INPUT
3	GND

M12 plug

**Ordering code**

**5300.T12**



**Plugs**

M8 plug

**Ordering code**

**5300.T08**



Manifold layout configuration complete with Serial systems

1  
AIR DISTRIBUTION

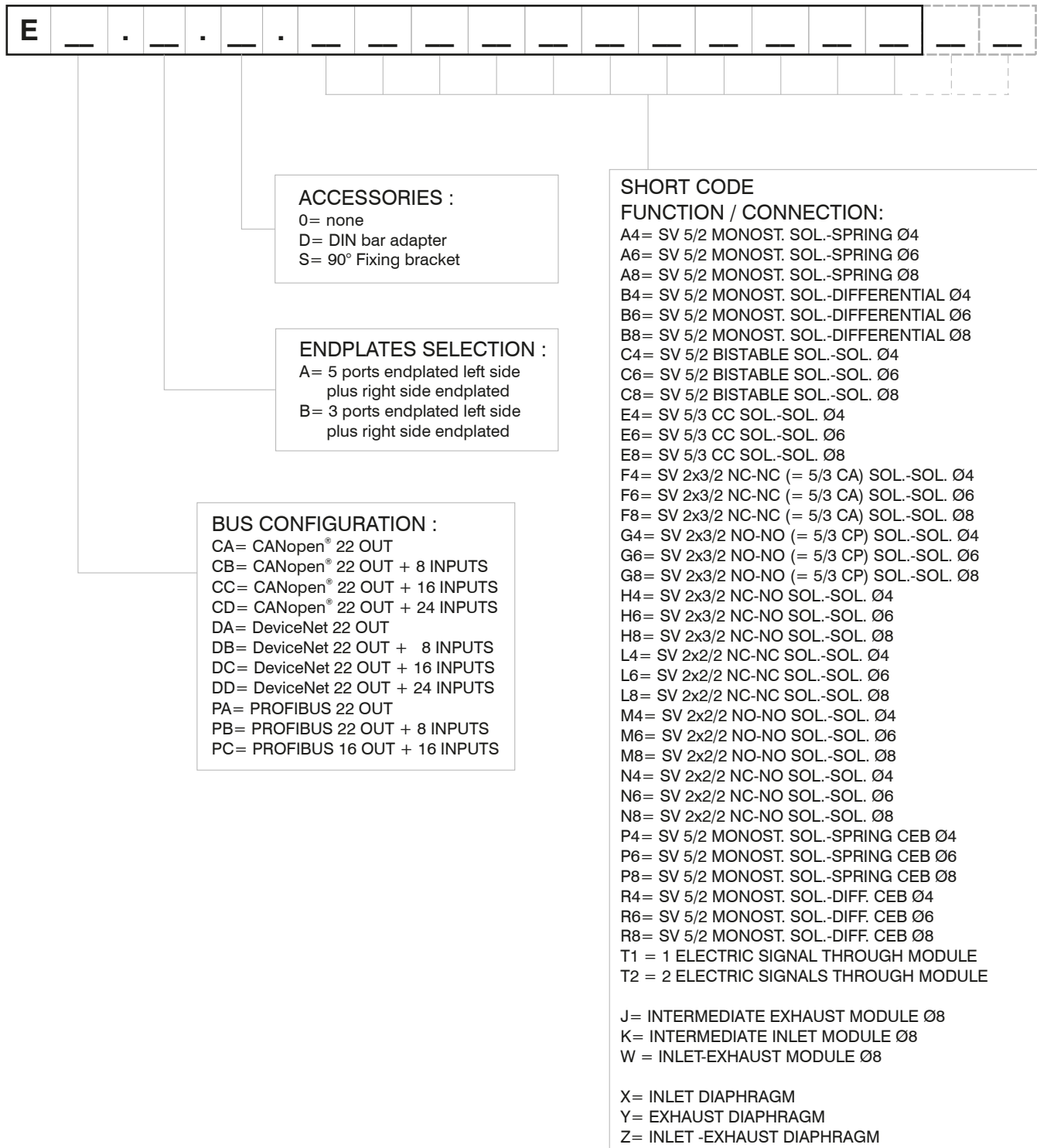

**NOTE:**

While configuring the manifold always bear in mind that the maximum number of electrical signals available is 22.

**N.B.** CEB = Electrical connector for bistable valves ( uses two electric signals)

Intermediate supply / exhaust modules require the same space as a valve but do not use any electric signals (as the electric connector carries forward all signals received from the module immediately before).

The separation diaphragms are positioned between two modules and replace the standard seal therefore do not increase the dimension of the assembly. When using a separation diaphragm of any type, it is necessary to add, in any position between diaphragm and the manifold and plate, an extra air supply / exhaust module depending on the type of diaphragm used.





## Series 2200 "OPTYMA-S"

### General

Optyma32-S has been designed in order to complete the Optyma series of valves. Optyma-S, 12.5mm size, integrates all the technical features already developed and implemented on the Optima T & F such as the integrated electrical connection. Further technical specifications are:

- Flow rate: up to 550[Nl/min], using the modular base with Ø8 quick fitting tube.
- Modular base available with Ø4, Ø6, Ø8 quick fitting tube.
- The solenoid pilots are low consumption and fitted on the same side of the valve.
- Mono and bistable valves have the same dimension.
- Easy and fast assembly on the sub base thanks to the "one screw" mounting solution.
- Possibility to replace a valve without the need of disconnecting the pneumatic pipes.
- Electrical and pneumatic connections positioned on the same side.
- Possibility to operate with different pressures and vacuum.
- Management of 32 electrical signals, (16 bi-stable or any combination off mono and bi-stable vales up to max 32 signals).
- The protection grade is IP65 directly integrated in the manifold components.
- The electrical connection is achieved thanks to a 37 pole connector.
- Possibility to integrate with Field Bus modules CANopen®, PROFIBUS DP, DeviceNet, EtherNet/IP, PROFINET IO RT/IRT, EtherCAT® e CC-Link IE Field Basic.

**"Shifting time of pneumatic directional control valves or moving parts, logic devices were measured in accordance to ISO 12238:2001, Pneumatic fluid power-Directional control valves-Measurement of shifting time"**

### Main characteristics

- One size: 12.5mm thick
- Monostable and bistable valves with same dimensions
- Modular subbase with two positions
- Modular subbases assembled via tie rods
- Quick coupling connections directly integrated in sub base
- Integrated and optimized electrical connection system.
- IP65 protection grade as standard

### Construction characteristics

Body	Technopolymer
Operators	Technopolymer
Spacers	NBR
Spacer	Technopolymer
Spools	AISI 303 stainless steel
Springs	AISI 303 stainless steel
Pistons	Technopolymer
Piston seals	NBR

### Functions

- SV 5/2 MONOSTABLE SOLENOID-SPRING
- SV 5/2 MONOSTABLE SOLENOID-DIFFERENTIAL
- SV 5/2 BISTABLE SOLENOID-SOLENOID
- SV 5/3 C.C. SOLENOID-SOLENOID
- SV 2x3/2 N.C.-N.C. (=5/3 O.C.) SOLENOID-SOLENOID
- SV 2x3/2 N.O.-N.O. (=5/3 P.C.) SOLENOID-SOLENOID
- SV 2x3/2 N.C.-N.O. SOLENOID-SOLENOID
- SV 2x3/2 N.O.-N.C. SOLENOID-SOLENOID

### Technical characteristics

Voltage	24VDC ±10% PNP (NPN and AC on request)
Pilot consumption	0,5 Watt
Pilot working pressure (12-14)	from 2,5 to 7 bar max.
Valve working pressure [1]	from vacuum to 10 bar max.
Operating temperature	from -5°C to +50°C
Protection degree	IP65
Life (standard operating conditions)	50000000
Fluid	Filtered air. No lubrication needed, if applied it shall be continuous



# Solenoid valves manifold Series 2200 "OPTYMA-S"

1  
AIR DISTRIBUTION

## Solenoid - Spring

Coding: 2241.52.00.39.

Operational characteristics	
Fluid	Filtered air. No lubrication needed, if applied it shall be continuous
Working pressure (bar)	From vacuum to 10
Pressure range (bar)	2,5 ÷ 7
Temperature °C	-5 ÷ +50
Flow rate at 6 bar with Δp=1 (NI/min)	550
Response time according to ISO 12238, activation time (ms)	12
Response time according to ISO 12238, deactivation time (ms)	20

VOLTAGE	
	02 = 24 VDC PNP
	12 = 24 VDC NPN
	05 = 24 VAC

SHORT FUNCTION CODE "A"  
Weight 67 g

*Shifting time of pneumatic directional control valves or moving parts, logic devices were measured in accordance to ISO 12238:2001*

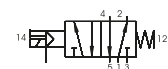
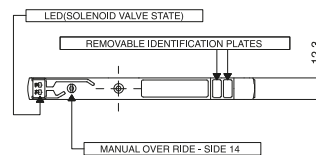
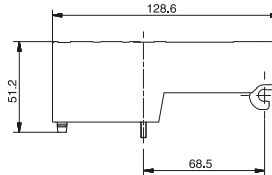
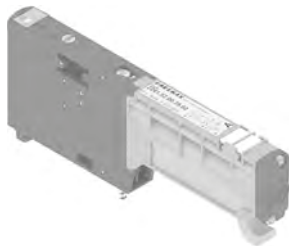

Flow rate at 6 bar with Δp=1 (NI/min) with Base cod. 2244.01. tube Ø4= 140  
Flow rate at 6 bar with Δp=1 (NI/min) with Base cod. 2246.01. tubo Ø6= 400  
Flow rate at 6 bar with Δp=1 (NI/min) with Base cod. 2246.01. tubo Ø8= 550

## Solenoid-Differential

Coding: 2241.52.00.36.

Operational characteristics	
Fluid	Filtered air. No lubrication needed, if applied it shall be continuous
Working pressure (bar)	From vacuum to 10
Pressure range (bar)	2,5 ÷ 7
Temperature °C	-5 ÷ +50
Flow rate at 6 bar with Δp=1 (NI/min)	550
Response time according to ISO 12238, activation time (ms)	20
Response time according to ISO 12238, deactivation time (ms)	25

VOLTAGE	
	02 = 24 VDC PNP
	12 = 24 VDC NPN
	05 = 24 VAC

SHORT FUNCTION CODE "B"  
Weight 67 g

*Shifting time of pneumatic directional control valves or moving parts, logic devices were measured in accordance to ISO 12238:2001*

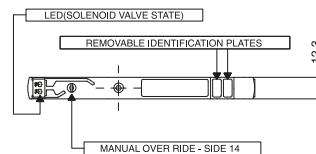
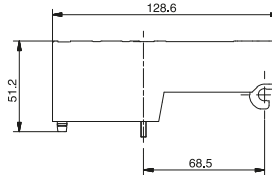
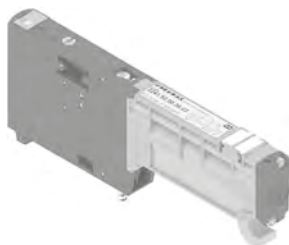

Flow rate at 6 bar with Δp=1 (NI/min) with Base cod. 2244.01. tube Ø4= 140  
Flow rate at 6 bar with Δp=1 (NI/min) with Base cod. 2246.01. tubo Ø6= 400  
Flow rate at 6 bar with Δp=1 (NI/min) with Base cod. 2246.01. tubo Ø8= 550

## Solenoid-Solenoid

Coding: 2241.52.00.35.

Operational characteristics	
Fluid	Filtered air. No lubrication needed, if applied it shall be continuous
Working pressure (bar)	From vacuum to 10
Pressure range (bar)	2,5 ÷ 7
Temperature °C	-5 ÷ +50
Flow rate at 6 bar with Δp=1 (NI/min)	550
Response time according to ISO 12238, activation time (ms)	10
Response time according to ISO 12238, deactivation time (ms)	10

VOLTAGE	
	02 = 24 VDC PNP
	12 = 24 VDC NPN
	05 = 24 VAC

SHORT FUNCTION CODE "C"  
Weight 67 g

*Shifting time of pneumatic directional control valves or moving parts, logic devices were measured in accordance to ISO 12238:2001*

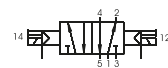
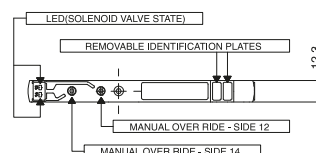
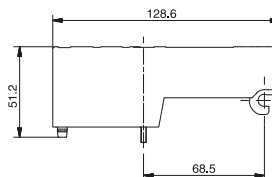
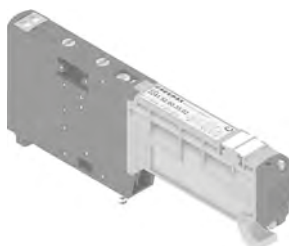

Flow rate at 6 bar with Δp=1 (NI/min) with Base cod. 2244.01. tube Ø4= 140  
Flow rate at 6 bar with Δp=1 (NI/min) with Base cod. 2246.01. tubo Ø6= 400  
Flow rate at 6 bar with Δp=1 (NI/min) with Base cod. 2246.01. tubo Ø8= 550

**Solenoid-Solenoid 5/3 (Closed centres)**

Coding: 2241.53.31.35.

Operational characteristics	
Fluid	Filtered air. No lubrication needed, if applied it shall be continuous
Working pressure (bar)	From vacuum to 10
Pressure range (bar)	2,5 ÷ 7
Temperature °C	-5 ÷ +50
Flow rate at 6 bar with $\Delta p=1$ (NI/min)	400
Response time according to ISO 12238, activation time (ms)	15
Response time according to ISO 12238, deactivation time (ms)	20

VOLTAGE	<b>02</b> = 24 VDC PNP
	<b>12</b> = 24 VDC NPN
	<b>05</b> = 24 VAC

SHORT FUNCTION CODE "E"  
Weight 83 g

Shifting time of pneumatic directional control valves or moving parts, logic devices were measured in accordance to ISO 12238:2001

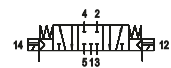
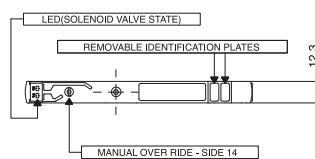
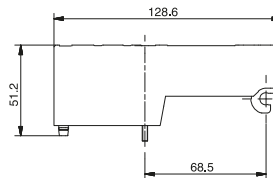
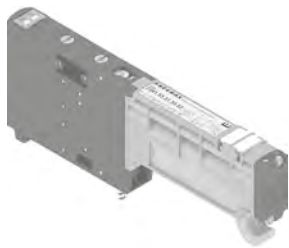

Flow rate at 6 bar with  $\Delta p=1$  (NI/min) with Base cod. 2244.01. tube  $\varnothing 4 = 140$   
Flow rate at 6 bar with  $\Delta p=1$  (NI/min) with Base cod. 2246.01. tube  $\varnothing 6 = 300$   
Flow rate at 6 bar with  $\Delta p=1$  (NI/min) with Base cod. 2246.01. tubo  $\varnothing 8 = 400$

**Solenoid-Solenoid 2x3/2**

Coding: 2241.62. .35.

Operational characteristics	
Fluid	Filtered air. No lubrication needed, if applied it shall be continuous
Working pressure (bar)	From vacuum to 10
Pressure range (bar)	$\geq 3 + (0,2 \times \text{Inlet pressure})$
Temperature °C	-5 ÷ +50
Flow rate at 6 bar with $\Delta p=1$ (NI/min)	420
Response time according to ISO 12238, activation time (ms)	15
Response time according to ISO 12238, deactivation time (ms)	25

FUNCTION	<b>44</b> = NC-NC (5/3 Open centres)
	<b>45</b> = NC-NO (normally closed-normally open)
	<b>54</b> = NO-NC (normally open-normally closed)
	<b>55</b> = NO-NO (5/3 Pressured centres)
VOLTAGE	<b>02</b> = 24 VDC PNP
	<b>12</b> = 24 VDC NPN
	<b>05</b> = 24 VAC

SHORT FUNCTION CODE:  
NC-NC (5/3 Open centres) = "F"  
NO-NO (5/3 Pressured centres) = "G"  
NC-NO = "H"  
NO-NC = "I"  
Weight 75 g

Shifting time of pneumatic directional control valves or moving parts, logic devices were measured in accordance to ISO 12238:2001

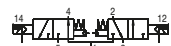
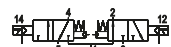
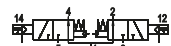
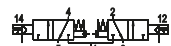
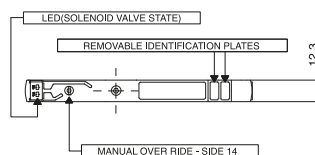
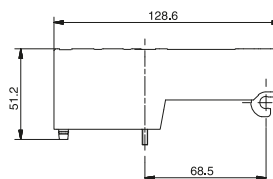
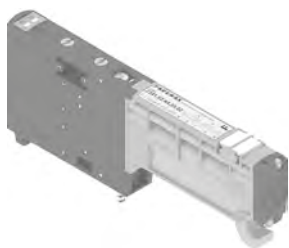

Flow rate at 6 bar with  $\Delta p=1$  (NI/min) with Base cod. 2244.01. tube  $\varnothing 4 = 140$   
Flow rate at 6 bar with  $\Delta p=1$  (NI/min) with Base cod. 2246.01. tubo  $\varnothing 6 = 360$   
Flow rate at 6 bar with  $\Delta p=1$  (NI/min) with Base cod. 2246.01. tubo  $\varnothing 8 = 420$

**Left Endplates**

Coding: 2240.02.0

Operational characteristics	
Fluid	Filtered air. No lubrication needed, if applied it shall be continuous
Working pressure (bar)	From vacuum to 10 (External pilot base) 2,5-7 (Self-feeding base)
Pressure range (bar)	2,5 ÷ 7 (External pilot base)
Temperature °C	-5 ÷ +50

VERSION	
02	= External feeding
12	= Self-feeding
ELECTRICAL CONNECTION	
37P	= Connectors 37 poles
PNP	
25P	= Connectors 25 poles
PNP	
37N	= Connectors 37 poles
NPN	
25N	= Connectors 25 poles
NPN	
37A	= Connectors 37 poles
AC	
25A	= Connectors 25 poles
AC	

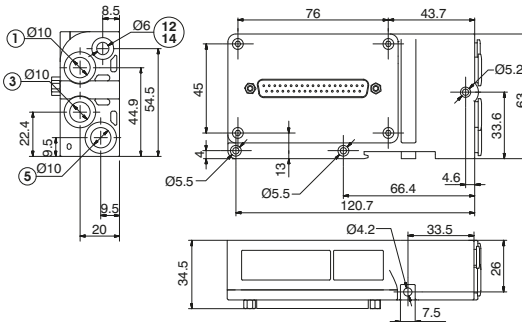

Weight 174 g  
12/14 separated from port 1

2240.02.0

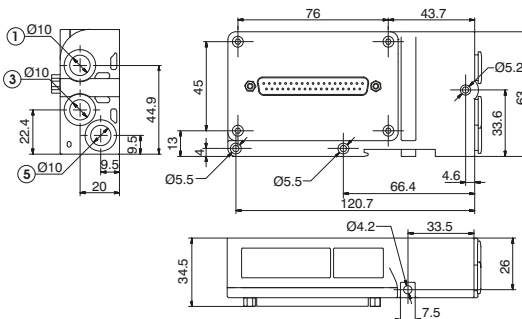

Weight 174 g  
12/14 connected to port 1

2240.12.0

**Right Endplates**

Coding: 2240.03.0

Operational characteristics	
Fluid	Filtered air. No lubrication needed, if applied it shall be continuous
Working pressure (bar)	From vacuum to 10
Pressure range (bar)	2,5 ÷ 7
Temperature °C	-5 ÷ +50

ELECTRICAL CONNECTION	
00	= Electrical connection
25P	= Connectors 25 poles

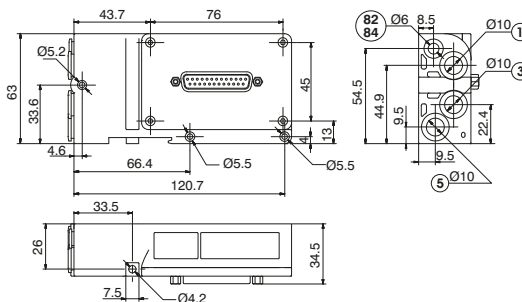
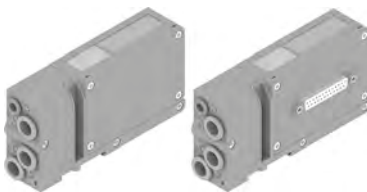

Weight 147 g  
PORT 82/84= DO NOT PRESSURIZE, SOLENOID PILOTS EXHAUST

**Closing plate**

Coding: 2240.00

Operational characteristics	
Fluid	Filtered air. No lubrication needed, if applied it shall be continuous
Working pressure (bar)	From vacuum to 10
Temperature °C	-5 ÷ +50

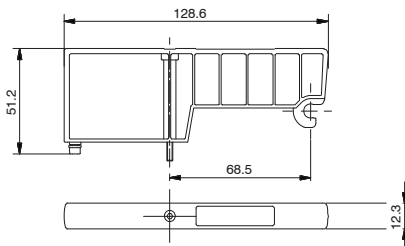

Weight 30 g  
SHORT FUNCTION CODE "T"

1 AIR DISTRIBUTION

Intermediate Inlet/Exhaust module

Coding: 2240.10

Operational characteristics	
Fluid	Filtered air. No lubrication needed, if applied it shall be continuous
Working pressure (bar)	From vacuum to 10
Temperature °C	-5 ÷ +50

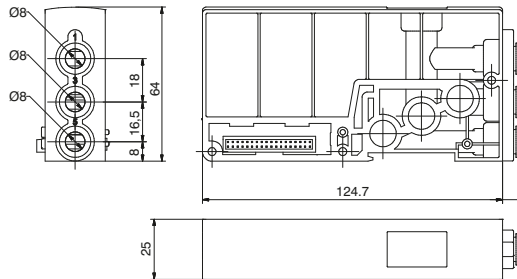

Weight 105 g  
SHORT FUNCTION CODE "W"

Modular base (2 places)

Coding: 224C.F.V

Operational characteristics	
Fluid	Filtered air. No lubrication needed, if applied it shall be continuous
Working pressure (bar)	From vacuum to 10
Temperature °C	-5 ÷ +50



2244.F.V

Weight 75 g

SHORT FUNCTION CODE "3" (Monostable) Opened ports  
SHORT FUNCTION CODE "33" (Monostable) Ports 1-5 separated  
SHORT FUNCTION CODE "34" (Monostable) Ports 1-3 separated  
SHORT FUNCTION CODE "35" (Monostable) Port 5 separated  
SHORT FUNCTION CODE "36" (Monostable) Separated ports  
SHORT FUNCTION CODE "37" (Monostable) Port 1 separated  
SHORT FUNCTION CODE "38" (Monostable) Ports 3-5 separated  
SHORT FUNCTION CODE "39" (Monostable) Port 3 separated

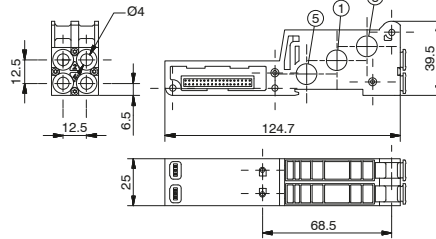

SHORT FUNCTION CODE "4" (Bistable) Opened ports  
SHORT FUNCTION CODE "43" (Bistable) Ports 1-5 separated  
SHORT FUNCTION CODE "44" (Bistable) Ports 1-3 separated  
SHORT FUNCTION CODE "45" (Bistable) Port 5 separated  
SHORT FUNCTION CODE "46" (Bistable) Separated ports  
SHORT FUNCTION CODE "47" (Bistable) Port 1 separated  
SHORT FUNCTION CODE "48" (Bistable) Ports 3-5 separated  
SHORT FUNCTION CODE "49" (Bistable) Port 3 separated

TUBE DIAMETER
4 = Ø4
6 = Ø6
8 = Ø8
FUNCTION
01 = Opened ports
03 = Ports 1-5 separated
04 = Ports 1-3 separated
05 = Ports 5 separated
06 = Separated ports
07 = Ports 1 separated
08 = Ports 3-5 separated
09 = Ports 3 separated
VERSION
M = for Monostable SV
B = for Bistable SV



2246.F.V

Weight 75 g

SHORT FUNCTION CODE "5" (Monostable) Opened ports  
SHORT FUNCTION CODE "53" (Monostable) Ports 1-5 separated  
SHORT FUNCTION CODE "54" (Monostable) Ports 1-3 separated  
SHORT FUNCTION CODE "55" (Monostable) Port 5 separated  
SHORT FUNCTION CODE "56" (Monostable) Separated ports  
SHORT FUNCTION CODE "57" (Monostable) Port 1 separated  
SHORT FUNCTION CODE "58" (Monostable) Ports 3-5 separated  
SHORT FUNCTION CODE "59" (Monostable) Port 3 separated

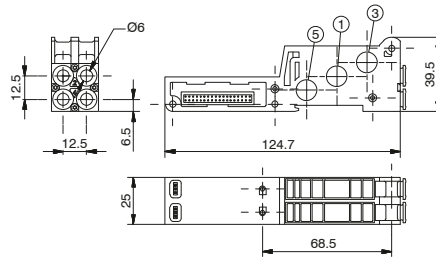

SHORT FUNCTION CODE "6" (Bistable) Opened ports  
SHORT FUNCTION CODE "63" (Bistable) Ports 1-5 separated  
SHORT FUNCTION CODE "64" (Bistable) Ports 1-3 separated  
SHORT FUNCTION CODE "65" (Bistable) Port 5 separated  
SHORT FUNCTION CODE "66" (Bistable) Separated ports  
SHORT FUNCTION CODE "67" (Bistable) Port 1 separated  
SHORT FUNCTION CODE "68" (Bistable) Ports 3-5 separated  
SHORT FUNCTION CODE "69" (Bistable) Port 3 separated



2248.F.V

Weight 75 g

SHORT FUNCTION CODE "7" (Monostable) Opened ports  
SHORT FUNCTION CODE "73" (Monostable) Ports 1-5 separated  
SHORT FUNCTION CODE "74" (Monostable) Ports 1-3 separated  
SHORT FUNCTION CODE "75" (Monostable) Port 5 separated  
SHORT FUNCTION CODE "76" (Monostable) Separated ports  
SHORT FUNCTION CODE "77" (Monostable) Port 1 separated  
SHORT FUNCTION CODE "78" (Monostable) Ports 3-5 separated  
SHORT FUNCTION CODE "79" (Monostable) Port 3 separated

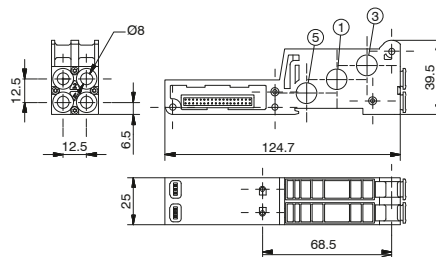

SHORT FUNCTION CODE "8" (Bistable) Opened ports  
SHORT FUNCTION CODE "83" (Bistable) Ports 1-5 separated  
SHORT FUNCTION CODE "84" (Bistable) Ports 1-3 separated  
SHORT FUNCTION CODE "85" (Bistable) Port 5 separated  
SHORT FUNCTION CODE "86" (Bistable) Separated ports  
SHORT FUNCTION CODE "87" (Bistable) Port 1 separated  
SHORT FUNCTION CODE "88" (Bistable) Ports 3-5 separated  
SHORT FUNCTION CODE "89" (Bistable) Port 3 separated



1 AIR DISTRIBUTION

**Polyethylene Silencer Series SPL-R**

Coding: SPLR. **D**



TUBEDIAMETER	
<b>D</b>	6 = 6 mm
	10 = 10 mm

**Diaphragm plug**

Coding: 2230.17



Weight 6,5 g

**Tie-rod M3**

Coding: 2240.KD.00



The Kit includes 6 pieces

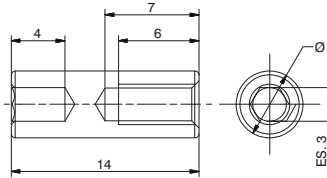

**Tie-rod M3**

Coding: 2240.KT. **P**



The Kit includes 3 pieces

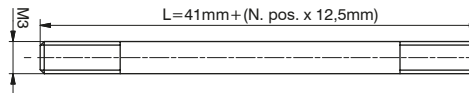

N. POSITIONS	
<b>02</b>	= Nr. 2 Positions
<b>04</b>	= Nr. 4 Positions
<b>06</b>	= Nr. 6 Positions
<b>08</b>	= Nr. 8 Positions
<b>10</b>	= Nr. 10 Positions
<b>12</b>	= Nr. 12 Positions
<b>14</b>	= Nr. 14 Positions
<b>P 16</b>	= Nr. 16 Positions
<b>18</b>	= Nr. 18 Positions
<b>20</b>	= Nr. 20 Positions
<b>22</b>	= Nr. 22 Positions
<b>24</b>	= Nr. 24 Positions
<b>26</b>	= Nr. 26 Positions
<b>28</b>	= Nr. 28 Positions
<b>30</b>	= Nr. 30 Positions
<b>32</b>	= Nr. 32 Positions

**Cable complete with connector, 25 Poles IP65**

Coding: 2300.25. **L.C**



CABLE LENGTH	
<b>L 03</b>	= 3 meters
<b>05</b>	= 5 meters
<b>10</b>	= 10 meters
FUNCTION	
<b>F 31</b>	= Closed centres
<b>32</b>	= Open centres
<b>33</b>	= Pressured centres

**Cable complete with connector, 37 Poles IP65**

Coding: 2400.37. **L.C**



CABLE LENGTH	
<b>L 03</b>	= 3 meters
<b>05</b>	= 5 meters
<b>10</b>	= 10 meters
FUNCTION	
<b>F 31</b>	= Closed centres
<b>32</b>	= Open centres
<b>33</b>	= Pressured centres

**Cable complete with connector, 25 Poles IP65**

Coding: 2400.25. **L.25**



CABLE LENGTH	
<b>L 03</b>	= 3 meters
<b>05</b>	= 5 meters
<b>10</b>	= 10 meters



**General :**

Using the 2240.03.25P output terminal it is possible to make any electrical signals not used by valves available on a 25 sub-D female connector at the right end of the manifold.  
It is possible to then join a multi-core cable to link to the next manifold, or connect directly to one or two I/O modules.  
The I/O modules can accept input or output signals, depending upon what is connected.

**Ordering code**

2240.08S



1  
AIR DISTRIBUTION

**Please note:** If the manifold is connected by a multi-core connection, each connection can be used as either an input or an output, while if the manifold is connected to a serial node the connections can only be used as an output.

It is possible to connect the manifold to up to two I/O modules.

Each I/O module includes 8 diagnostic LEDs which indicate the presence of an Input / Output signal for each connector.

**Please note:** For an LED to function, a signal of at least +15VDC must be present on pin 4 of the connector. If this signal is lower, the LED will not light, this does not compromise the normal Input / Output function of the unit.

**Overall dimensions and I/O layout:**

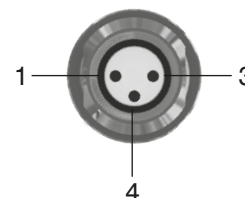
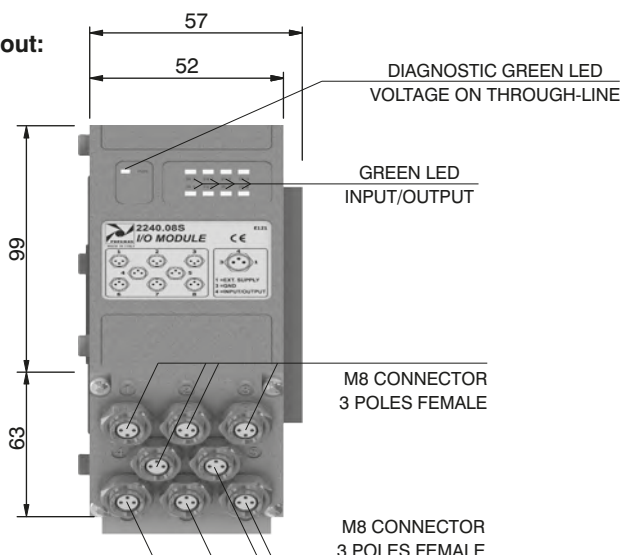

PIN	DESCRIPTION
1	+24 VDC
4	INPUT/OUTPUT
3	GND

**Input features:**

Each connection can accept either two wire (switches, magnetic switches, pressure switches, etc.) or three wire connections (photocells, electronic end of stroke sensors, etc.) if +24VDC is required on at Pin 1 of each connector, it is possible to provide this via the through-line pin of the multi-pole connector.

I.E.:

Pin 25 of the 25 pin multi-pole connector (code 2240.02.25P or 2240.12.25P)

Pin 36-37 of the 37 pin multi-pole connector (code 2240.02.37P or 2240.12.37P)

**Output features:**



**Attention:** The output connections are not protected against short-circuit. Please pay attention when wiring (avoid Pin 4 being connected to Pin 3 or Pin 1).

General characteristics		
Model		2240.08S
Case		Reinforced technopolymer
I/O Connector		M8 connector 3 poles female (IEC 60947-5-2)
PIN 1 voltage (connector used as Input)		by the user
PIN 4 voltage diagnosis		Green Led
Node consumption (Outlets excluded)		7mA per each LED with 24 VDC signal
Outlets voltage		+23,3 VDC (serial) /by the user (multipolar)
Input voltage		Depend by the using
Maximum outlet current		100 mA (serial) / 400 mA (multipolar)
Maximum Input/Output		8 per module
Multiconnector max. Current		100 mA
Connections to manifold		Direct connection to 25 poles connector
Maximum n. of moduls		2
Protection degree		IP65 when assembled
Ambient temperature		from -0° to +50° C

**CORRESPONDENCE BETWEEN MULTI-POLE SIGNAL AND CONNECTOR**

SUB-D TYPE 37 POLE MALE CONNECTOR

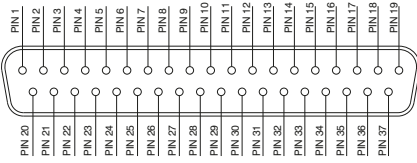

1 - 32 = SIGNALS  
 33 - 35 = GND  
 36 - 37 = THROUGH LINE

SUB-D TYPE 25 POLE MALE CONNECTOR

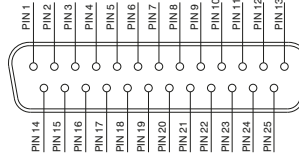

1 - 22 = SIGNALS  
 23 - 24 = GND  
 25 = THROUGH LINE

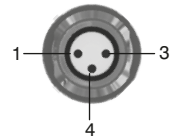

PIN	DESCRIPTION
1	THROUGH LINE
4	SIGNAL
3	GND

**Connection modes:**

The I/O module changes its operation depending on the way the manifold is controlled. There are two possible modes:

- A) Control via multi-pole connection
- B) Control via fieldbus

**A) Control via multi-pole :**

*M8 connector used as Input:*



**Attention:** Voltage applied to each connector is passed to multi-pole connector pin.

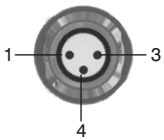

PIN	DESCRIPTION
1	THROUGH LINE
4	SIGNAL
3	GND

In order to use the I/O module, the correct right hand endplate with 25 pole female outlet connector must be used. (Code 2240.03.25P).



*M8 connector used as Output:*

Output voltage will be the same as is applied at the multi-pole connector pin. The maximum output current depends upon the power unit used, but we recommend no more than 250mA.



**Attention:** Since every cable has a degree of resistance, there will always be a voltage drop depending on the cable's length, sectional area and the current.

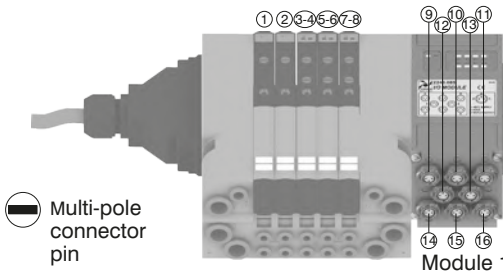

**Attention:** Only one more I/O module can be added.

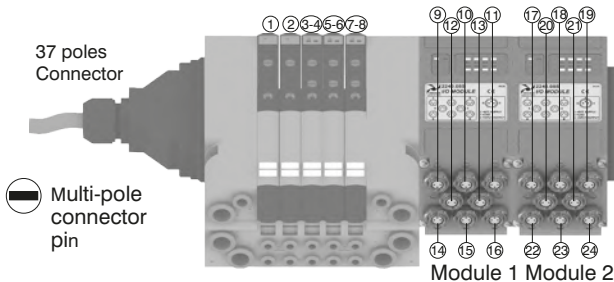

**Attention:** No more additions are possible

**Attention :** Optyma 32-S solenoid valve manifolds permit up to 22 electrical signals that are not used by manifolds to be made available: these signals can be managed by another manifold and / or by I/O modules.

The I/O module will manage these unused signals. Connections that are not managing useful signals will remain unconnected.

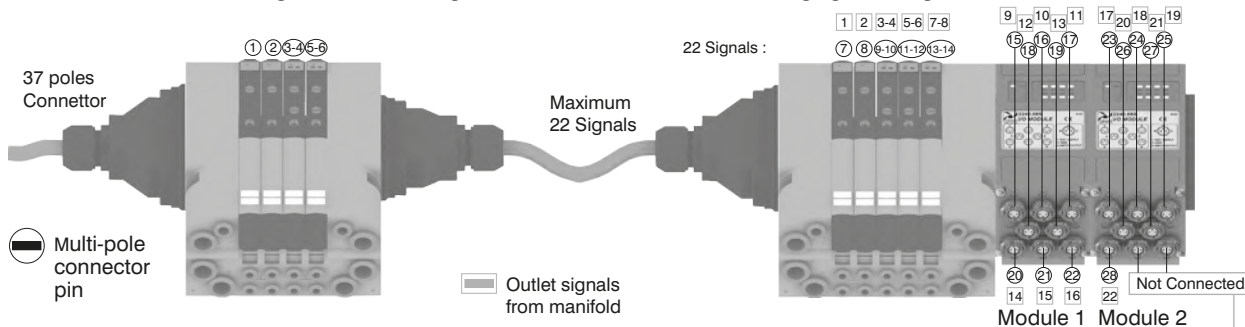

**Attention:** Signal Not connected  
 GND Connected  
 Through line Connected

**Please note:** this example considers a 37 pin multi-pole connector. The same configuration managed by a 25 pin multi-pole connector will stop at number 22 of multi-pole connector and at number 17 of the manifold. 20 16

AIR DISTRIBUTION 1





**Please note:** Optyma 32-S solenoid valve manifolds manage up to 32 signals. If the manifold uses more than 24 signals the I/O module will manage only the remainder. Connections that are not managing useful signals will remain unconnected.

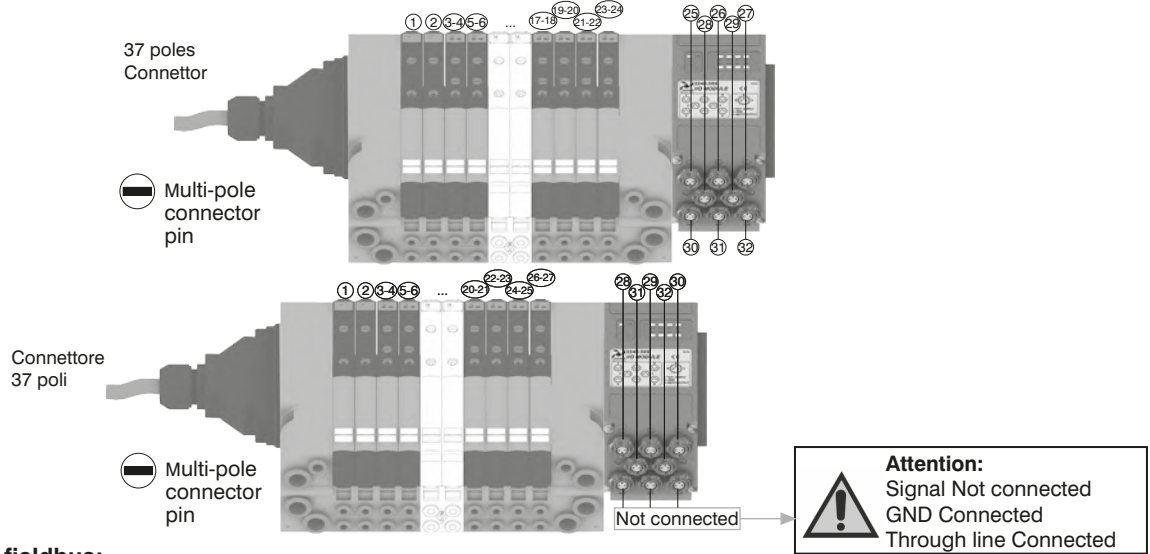

**B) Control via fieldbus:**

With this kind of control the I/O module can only be used as an output. Pin 1 of each connector is not connected. The output voltage will be 0.7V lower than that applied to Pin 4 of the connector.

The maximum output current for each output is 100mA. The correspondence between control byte and each single output depends on how many electrical signals are used by the manifold and by the relative position of the I/O module.

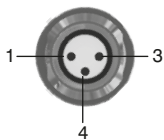

PIN	DESCRIPTION
1	NOT CONNECTED
4	SIGNAL
3	GND

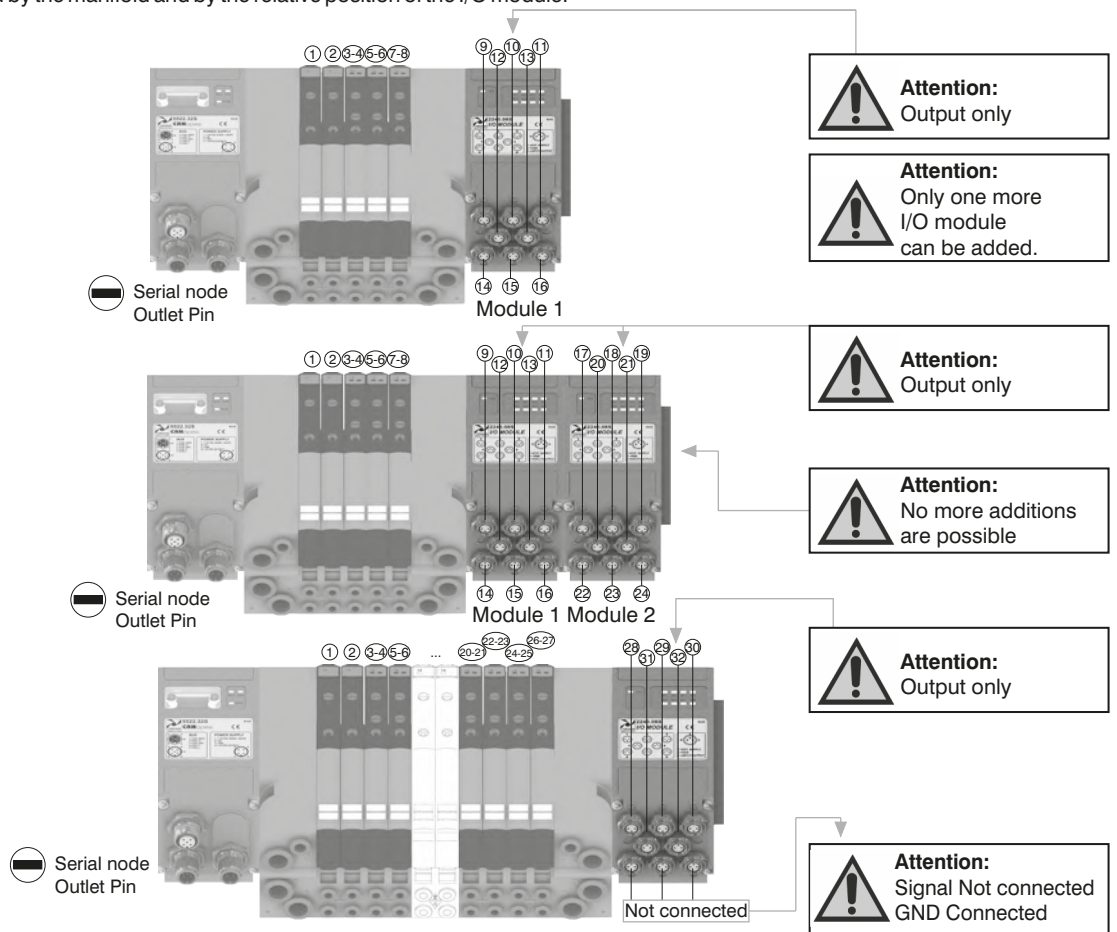

**Please note:** I/O modules don't allow to connect any additional valves manifold after them.

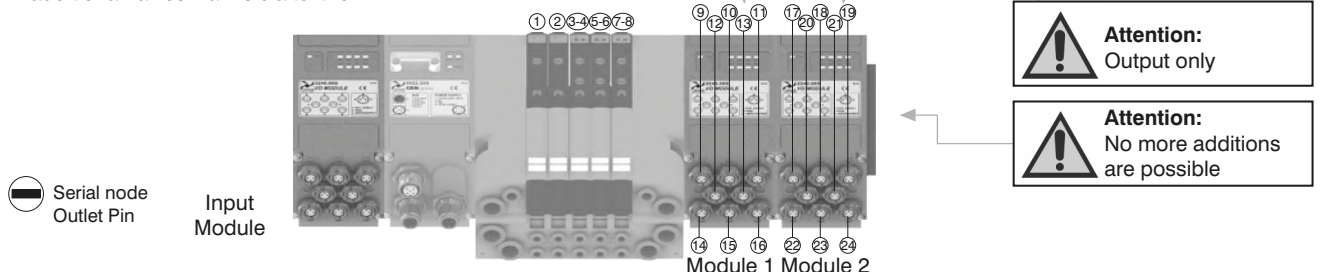



## Electrical connection

The electrical connection is made using a 37 pin connector and can manage up to 32 electrical signals. Alternatively a 25 pin connector can be used which is suitable for up to 22 electrical signals. The distributions of the electrical signals between sub-bases achieved thanks to a dedicated electrical connector positioned in each sub-base which diverts the signals needed to operate the solenoid pilots of the valve mounted on the sub-base and passing unused signals forward to the next base.

The Optyima-S sub-bases are designed to carry two valves and are available in the following configurations:

Sub-base configurations	Signals used for the single position	Total number of used signal
Sub-base for 2 bistable valves	2 signals used for the first position	4
	2 signals used for the second position	
Sub-base for 2 monostable valves	1 signal used for the first position	2
	1 signal used for the second position	

### Sub-base for 2 bistable valves

On the sub base for 2 bistable valves the first electrical signal is used to actuate the solenoid pilot on side 14 of the first position, the second signal is used to actuate the solenoid pilot on side 12 of the first position. Each sub base uses 4 electric signals. The same layout applies to the following position therefore the third signal is used to actuate the solenoid pilot on side 14 of the second position and the fourth signal is used to actuate the solenoid pilot on side 12 of the second position. The remaining signals are transferred downstream.

On a bistable sub base it is possible to mount both bistable or monostable valves (in the second case 1 electrical signal for each valve is wasted). This solutions enables the user to change the manifold layout without the need to re-configure the output correspondence on the PLC. The use of bistable sub-bases reduces the maximum number of valves that can be mounted on the manifold: If the 37 pole connector is used the maximum number of valves is 16 If the 25 pole connector is used the maximum number of valves is 10.

### Sub-base for 2 monostable valves

On the sub base for 2 monostable valves the first electrical signal is used to actuate the solenoid pilot on side 14 of the first position, the second signal is used to actuate the solenoid pilot on side 12 of the second position. Each sub base uses 2 electric signals. The remaining signals are transferred downstream. On a monostable sub base it is possible to mount only monostable valves (shoud a bistable valve be mounted on a monostable sub base it will not be possible to actuate the solenoid pilot on side 12). This solutions enables the user to maximise the manifold lay out using all the electrical signals available.

If the 37 pole connector is used the maximum number of valves is 32

If the 25 pole connector is used the maximum number of valves is 22



**Note:**

Monostable valves, which are fitted with only one solenoid pilot can be mounted on both monostable or bistable sub bases.

Bistable valves ,5/3; 2x3/2;2x2/2, which are fitted with 2 solenoid pilots and therefore always use two electrical signals must always be mounted on bistable subbases.

### Additional exhaust and air supply modules:

The Additional exhaust and air supply module is fitted with a dedicated electrical connector which does not use any electric signal but simply carries forward all signals which have not been used by the valves mounted before it. This enables its use in any position of the manifold.

1 AIR DISTRIBUTION



**Unused electrical signals**

The electrical signals which have not been used in the manifold can be made available by using the end plate fitted with the 25 pole connector.

The number of electric signals available depends on the type of connector mounted on the inlet plate and on the number of signals used in the manifold:

- 37 pole Inlet connector : N. of outputs= 32 – used signals (max 22)
- 25 pole Inlet connector : N. of outputs= 22 – used signals

Here are some examples of possible configurations and the corresponding pin layout both on the inlet and end plate :

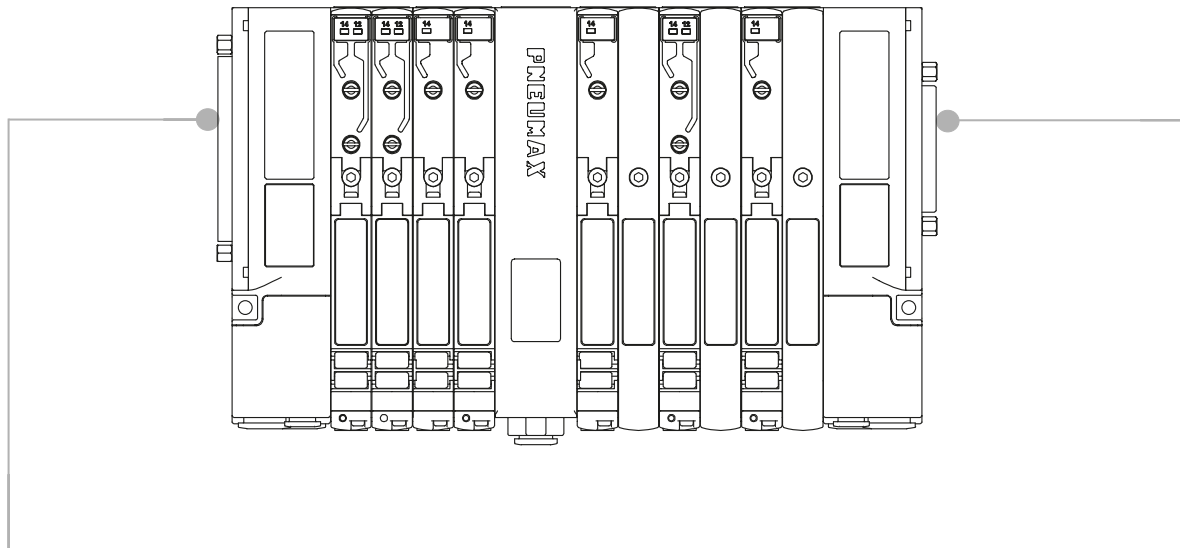

**INLET ELECTRIC CONNECTIONS**

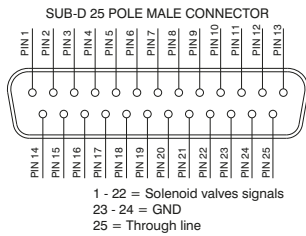
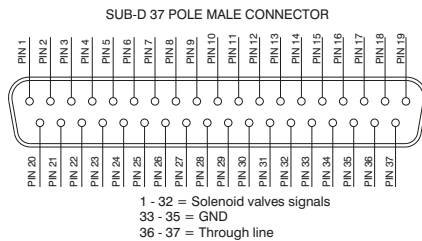

**OUTLET ELECTRIC CONNECTIONS (IF PRESENT)**

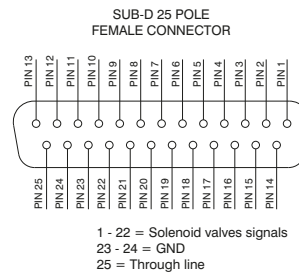

37 PIN Connector correspondence for valves assembled on mixed bases

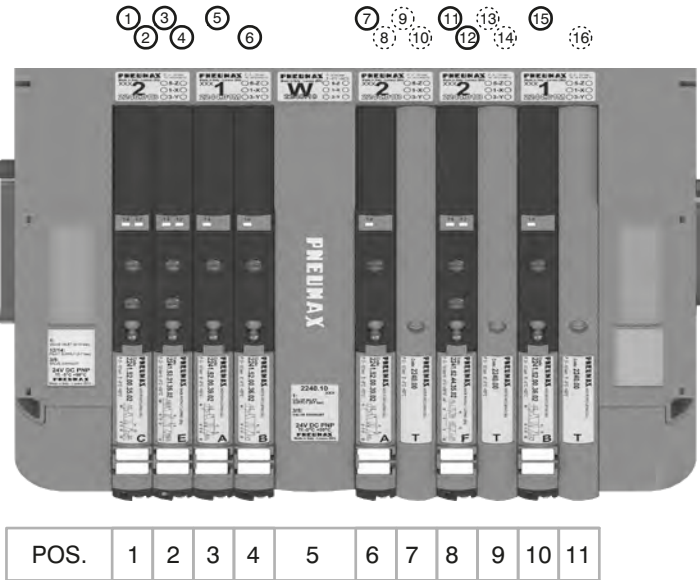

- PIN 1 = PILOT 14 SV POS.1
- PIN 2 = PILOT 12 SV POS.1
- PIN 3 = PILOT 14 SV POS.2
- PIN 4 = PILOT 12 SV POS.2
- PIN 5 = PILOT 14 SV POS.3
- PIN 6 = PILOT 14 SV POS.4
- PIN 7 = PILOT 14 SV POS.6
- PIN 8 = NOT CONNECTED
- PIN 9 = NOT CONNECTED
- PIN 10 = NOT CONNECTED
- PIN 11 = PILOT 14 SV POS.8
- PIN 12 = PILOT 12 SV POS.8
- PIN 13 = NOT CONNECTED
- PIN 14 = NOT CONNECTED
- PIN 15 = PILOT 14 SV POS.10
- PIN 16 = NOT CONNECTED

37 PIN Connector correspondence for manifold mounted on bases for bistable valves

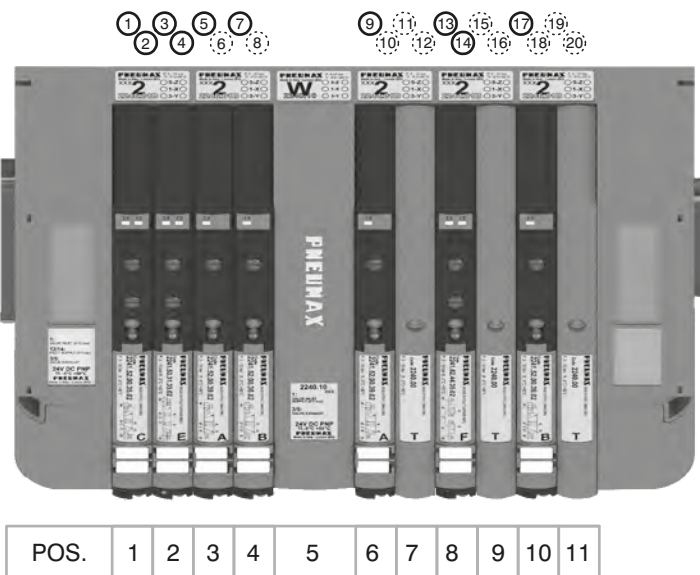

- PIN 1 = PILOT 14 SV POS.1
- PIN 2 = PILOT 12 SV POS.1
- PIN 3 = PILOT 14 SV POS.2
- PIN 4 = PILOT 12 SV POS.2
- PIN 5 = PILOT 14 SV POS.3
- PIN 6 = NOT CONNECTED
- PIN 7 = PILOT 14 SV POS.4
- PIN 8 = NOT CONNECTED
- PIN 9 = PILOT 14 SV POS.6
- PIN 10 = NOT CONNECTED
- PIN 11 = NOT CONNECTED
- PIN 12 = NOT CONNECTED
- PIN 13 = PILOT 14 SV POS.8
- PIN 14 = PILOT 12 SV POS.8
- PIN 15 = NOT CONNECTED
- PIN 16 = NOT CONNECTED
- PIN 17 = PILOT 14 SV POS.10
- PIN 18 = NOT CONNECTED
- PIN 19 = NOT CONNECTED
- PIN 20 = NOT CONNECTED

37 PIN Connector correspondence for manifold for 32 position manifold with monostable valves on double bases

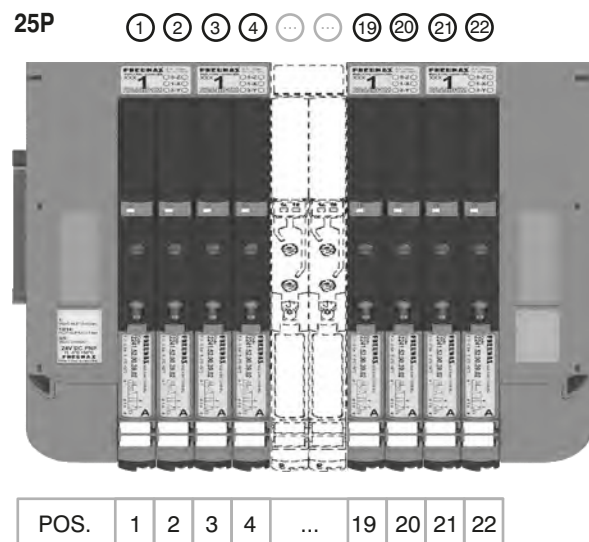
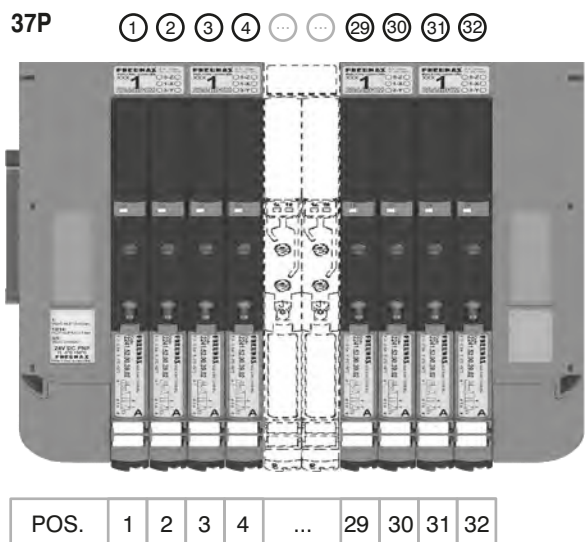

1 AIR DISTRIBUTION

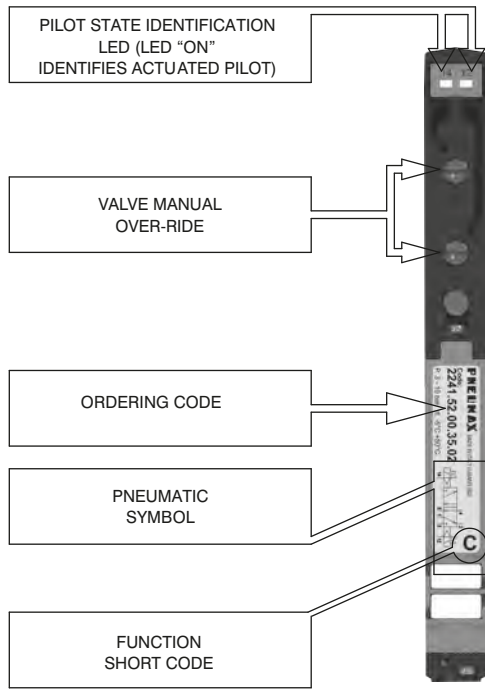

From the top

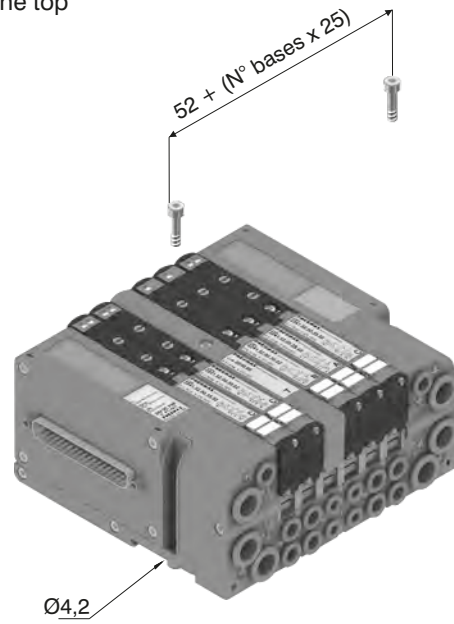

1  
AIR DISTRIBUTION

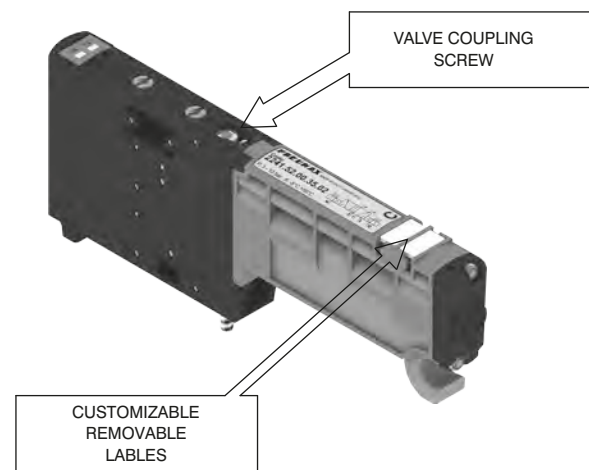

DIN rail fixing

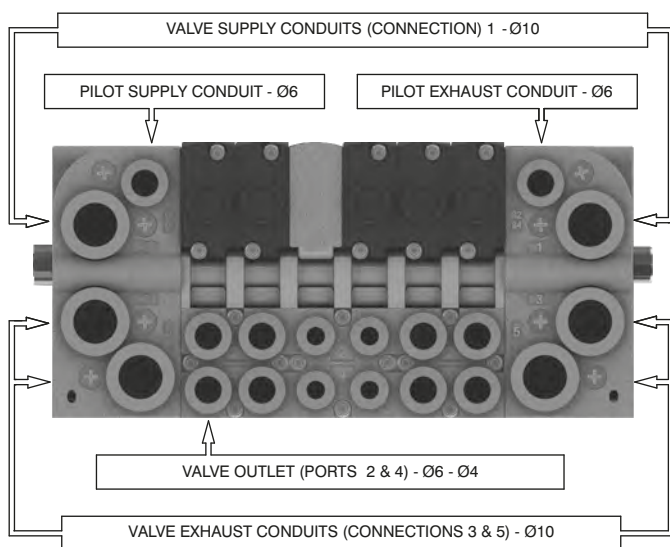
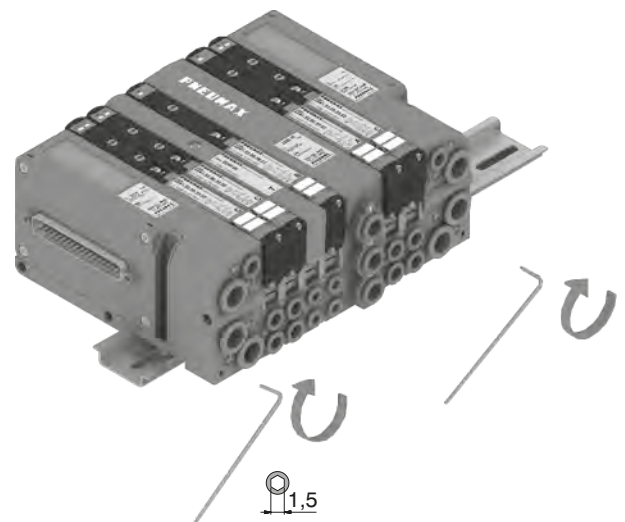

Maximum possible size  
According to valves used

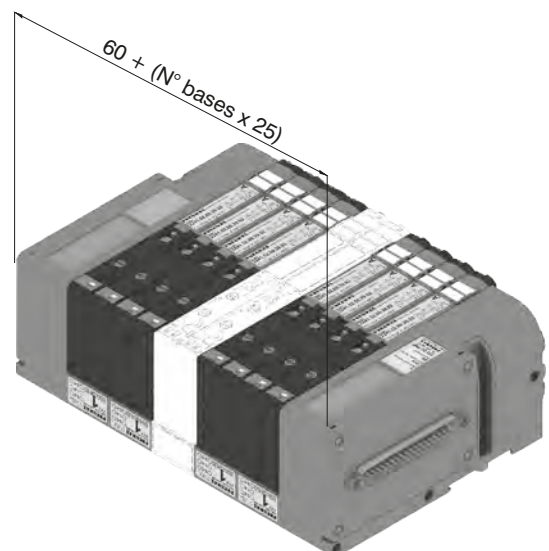

Manual override actuation

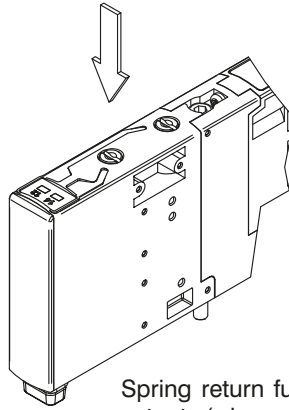
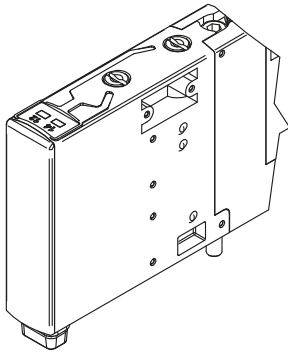

Spring return function: push to actuate (when released it moves back to the original position).

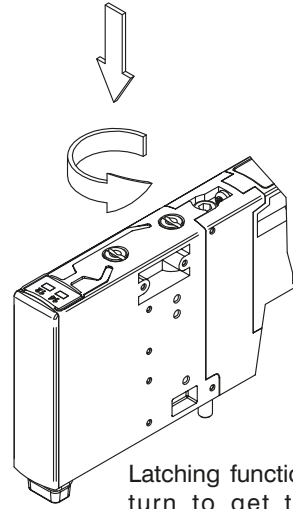

Latching function: push and turn to get the latching function

NOTE : It is strongly suggested to replace the original position after using

Valve Installation

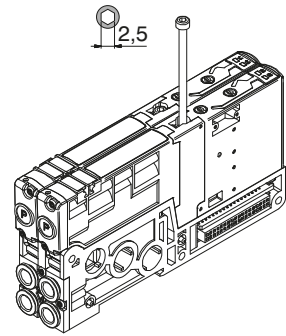
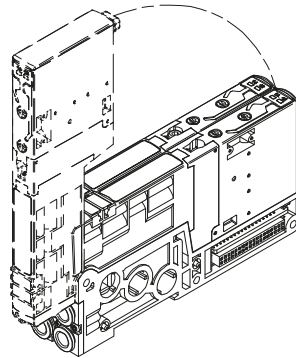
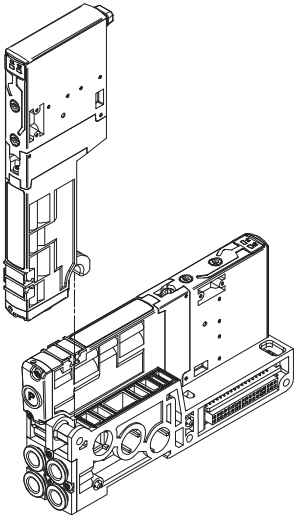

Torque moment (Nm) : 0,8

Manifold assembly

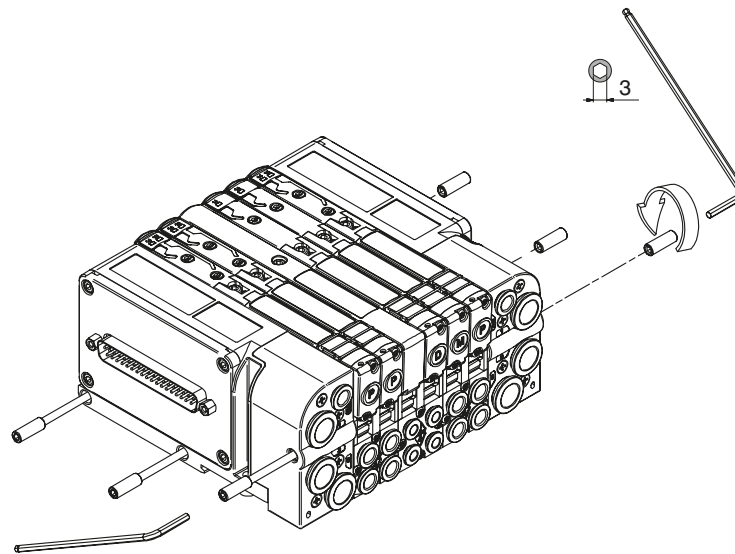

Min. torque moment : 2 Nm  
Max. torque moment: 2,5 Nm



Manifold Layout configuration

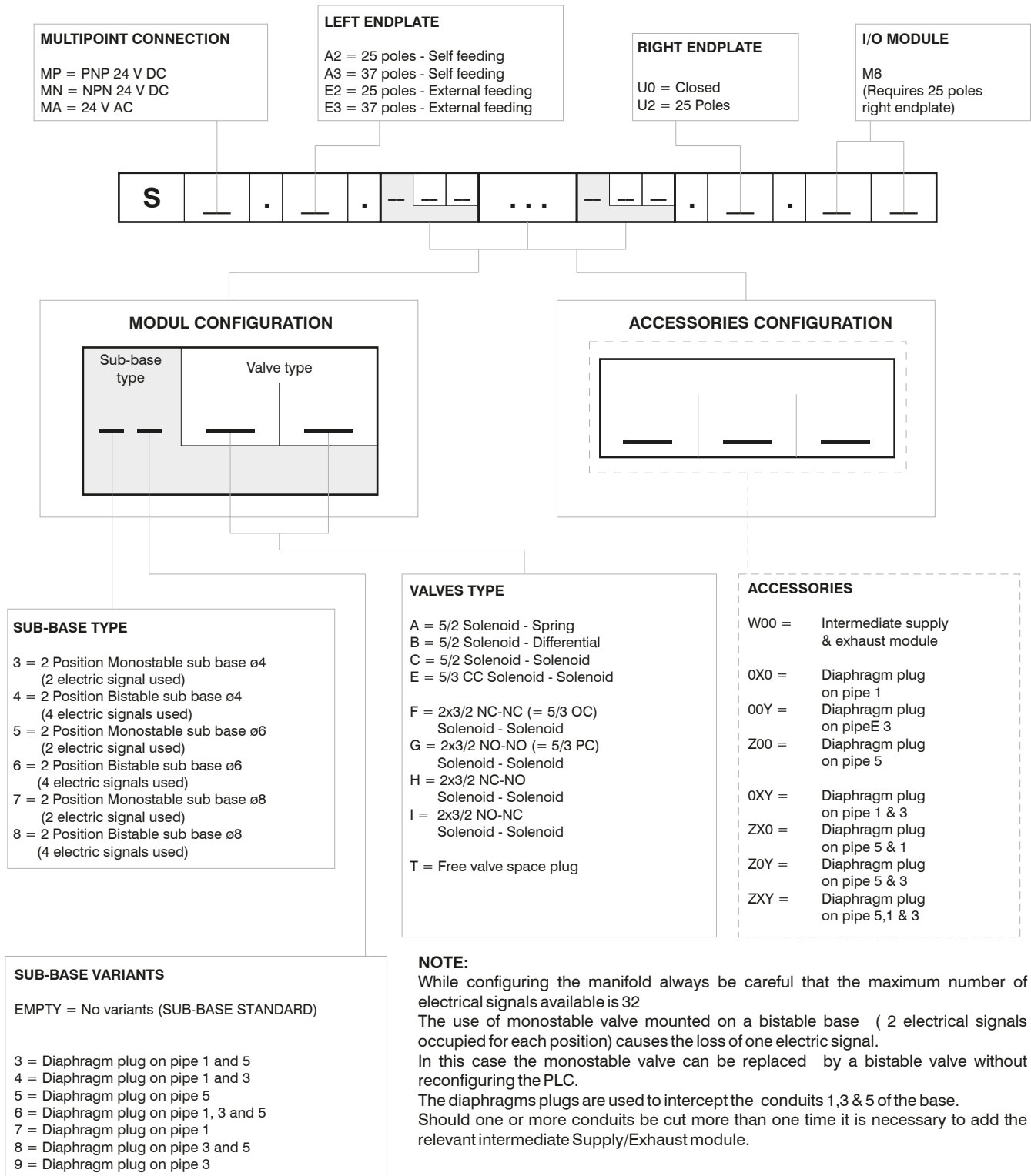

Series 2200 OPTYMA-S solenoid valve manifolds managed by multipoint connection are "well tried components"

	<b>Well-tryed component</b>	<ul style="list-style-type: none"> <li>- The product is a well-tryed product for a safety-related application according to ISO 13849-1.</li> <li>- The relevant basic and well-tryed safety principles according ISO 13849-2 for this product are fulfilled.</li> <li>- The suitability of the product for a precise application must be verified and confirmed by the user.</li> </ul>
<b>B<sub>10d</sub></b>	50.000.000	

**General:**

CANopen® module is directly integrated on Optyima-S solenoid valves manifold via a 37 poles connector, normally used for multipolar cable connection.  
 Optyima-S solenoid valves connected to node must be PNP equivalent (final 02 in ordering code).

The node can be easily installed also on solenoid valves manifold already mounted on equipment.

Module can manage up to 32 solenoid valves, and, in the same time, a max number of 4 Input modules 5222.08S.

CANopen® module recognizes automatically the presence of the Input modules on power on.

Regardless of the number of Input modules connected, the manageable solenoid valves are 32.

Node power supply is made by a M12 4P male circular connector.

The separation between node 24 VDC Power supply and outputs 24 VDC allows to switch off the outputs maintaining powered the node and inputs, if present.

Connection to Bus CANopen® is possible via 2 M12 5P male - female circular connectors; these two are connected in parallel and according to CiA Draft Recommendation 303-1 (V. 1.3 : 30 December 2004).

Transmission speed can be set by 3 dip-switches.

The node address can be set by 6 dip-switches using BCD numeration.

The module includes an internal terminating resistance that can be activated by a dip-switch.

**Ordering code**

**5522.32S**



**Scheme / Overall dimensions and I/O layout :**

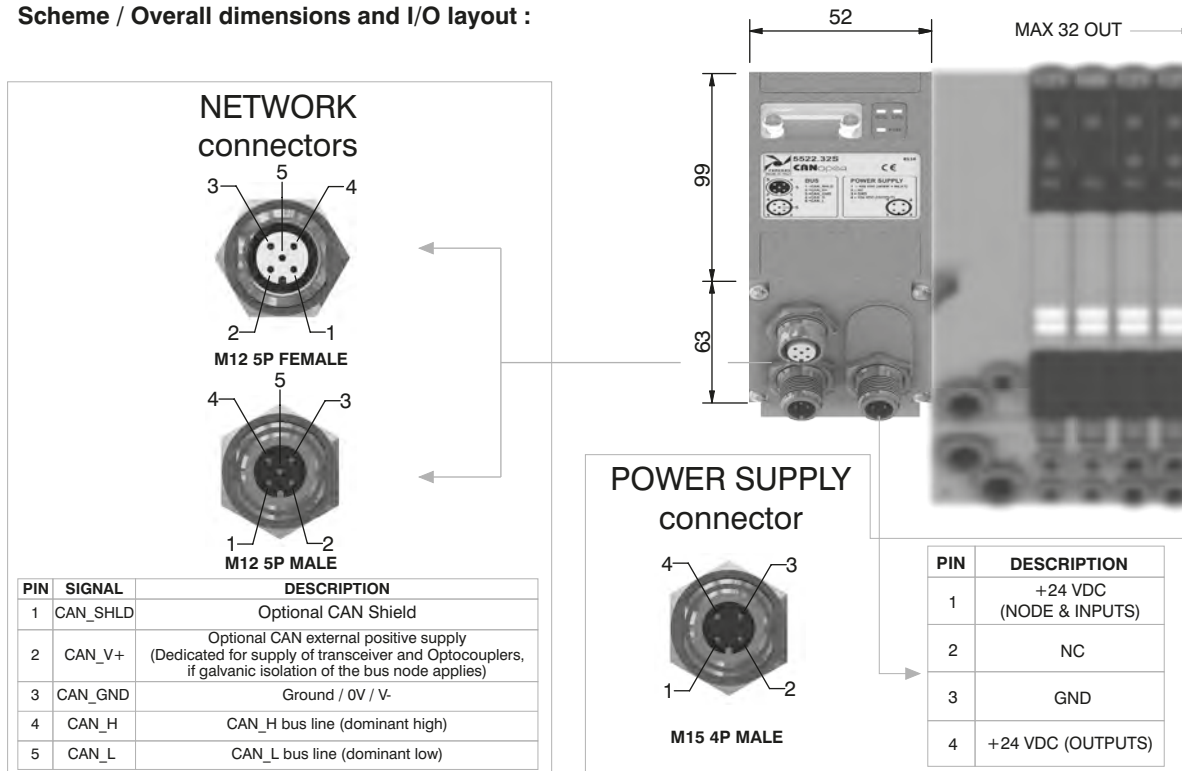

**Technical characteristics**

Model	5522.32S	
Specifications	CiA Draft Standard Proposal 301 V 4.10 (15 August 2006)	
Case	Reinforced technopolymer	
<b>Power supply</b>	Power supply connection	M12 4P male connector (IEC 60947-5-2)
	Power supply voltage	+24 VDC +/- 10%
	Node consumption (without inputs)	30 mA
	Power supply diagnosis	Green LED PWR
<b>Outputs</b>	PNP equivalent outputs	+24 VDC +/- 10%
	Maximum current for each output	100 mA
	Maximum output number	32
	Max output simultaneously actuated	32
<b>Network</b>	Network connectors	2 M12 5P connectors male-female Type A (IEC 60947-5-2)
	Baud rate	10 - 20 - 50 - 125 - 250 - 500 - 800 - 1000 Kbit/s
	Addresses, possible numbers	From 1 to 63
	Max nodes in net	64 (slave + master)
	Bus maximum recommended length	100 m at 500 Kbit/s
	Bus diagnosis	Green LED + Red LED
	Configuration file	Available from our web site: <a href="http://www.pneumaxspa.com">http://www.pneumaxspa.com</a>
	IP protection grade	IP65 when assembled
	Temperature range	From 0° to +50° C

1 AIR DISTRIBUTION



**General:**

DeviceNet module is directly integrated on Optyma-S solenoid valves manifold via a 37 poles connector, normally used for multipolar cable connection.  
Optyma-S solenoid valves connected to node must be PNP equivalent (final 02 in ordering code).

The node can be easily installed also on solenoid valves manifold already mounted on equipment.

Module can manage up to 32 solenoid valves, and, in the same time, a max number of 4 Input modules 5222.08S.

DeviceNet module recognizes automatically the presence of the Input modules on power on. Regardless of the number of Input modules connected, the manageable solenoid valves are 32. Node power supply is made by a M12 4P male circular connector.

The separation between node 24 VDC Power supply and outputs 24 VDC allows to switch off the outputs maintaining powered the node and inputs, if present.

Connection to Bus DeviceNet is possible via 2 M12 5P male - female circular connectors; these two are connected in parallel and according to DeviceNet Specifications Volume I, release 2.0.

Transmission speed can be set by 3 dip-switches.

The node address can be set by 6 dip-switches using BCD numeration.

The module includes an internal terminating resistance that can be activated by a dip-switch.

**Ordering code**

**5422.32S**



**Scheme / Overall dimensions and I/O layout :**

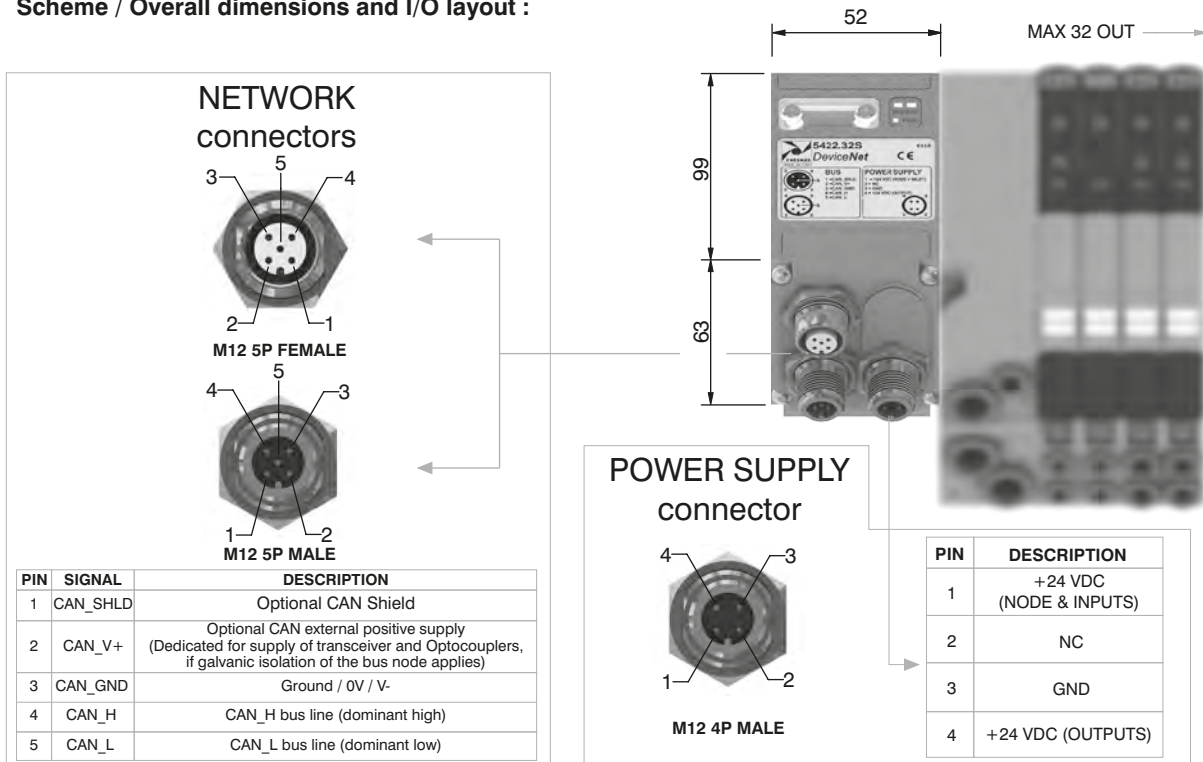

**Technical characteristics**

Model	5422.32S	
Specifications	DeviceNet Specifications Volume I, release 2.0.	
Case	Reinforced technopolymer	
<b>Power supply</b>	Power supply connection	M12 4P male connector (IEC 60947-5-2)
	Power supply voltage	+24 VDC +/- 10%
	Node consumption (without inputs)	30 mA
	Power supply diagnosis	Green LED PWR
<b>Outputs</b>	PNP equivalent outputs	+24 VDC +/- 10%
	Maximum current for each output	100 mA
	Maximum output number	32
	Max output simultaneously actuated	32
<b>Network</b>	Network connectors	2 M12 5P connectors male-female Type A (IEC 60947-5-2)
	Baud rate	125 - 250 - 500 Kbit/s
	Addresses, possible numbers	From 1 to 63
	Max nodes in net	64 (slave + master)
	Bus maximum recommended length	100 m at 500 Kbit/s
	Bus diagnosis	Green LED + Red LED
	Configuration file	Available from our web site: <a href="http://www.pneumaxspa.com">http://www.pneumaxspa.com</a>
	IP protection grade	IP65 when assembled
	Temperature range	From 0° to +50° C

**General:**

PROFIBUS DP module is directly integrated on Optyma-S solenoid valves manifold via a 37 poles connector, normally used for multipolar cable connection.  
 Optyma-S solenoid valves connected to node must be PNP equivalent (final 02 in ordering code).  
 The node can be easily installed also on solenoid valves manifold already mounted on equipment.  
 Module can manage up to 32 solenoid valves, and, in the same time, a max number of 4 Input modules 5222.08S.  
 PROFIBUS DP module recognizes automatically the presence of the Input modules on power on.  
 Regardless of the number of Input modules connected, the managable solenoid valves are 32.  
 Node power supply is made by a M12 4P male circular connector.  
 The separation between node 24 VDC Power supply and outputs 24 VDC allows to switch off the outputs mantaining powered the node and inputs, if present.  
 Connection to Bus PROFIBUS DP is possible via 2 M12 type B 5P male - female circular connectors; these two are connected in parallel and according to PROFIBUS Interconnection Technology (Version 1.1 : August 2001).  
 The node address can be set using BCD numeration: 4 dip-switches for the units and 4 dip-switches for the tens.  
 The module includes an internal terminating resistance that can be activated by a dip-switch.

**Ordering code**

**5322.32S**



**Scheme / Overall dimensions and I/O layout :**

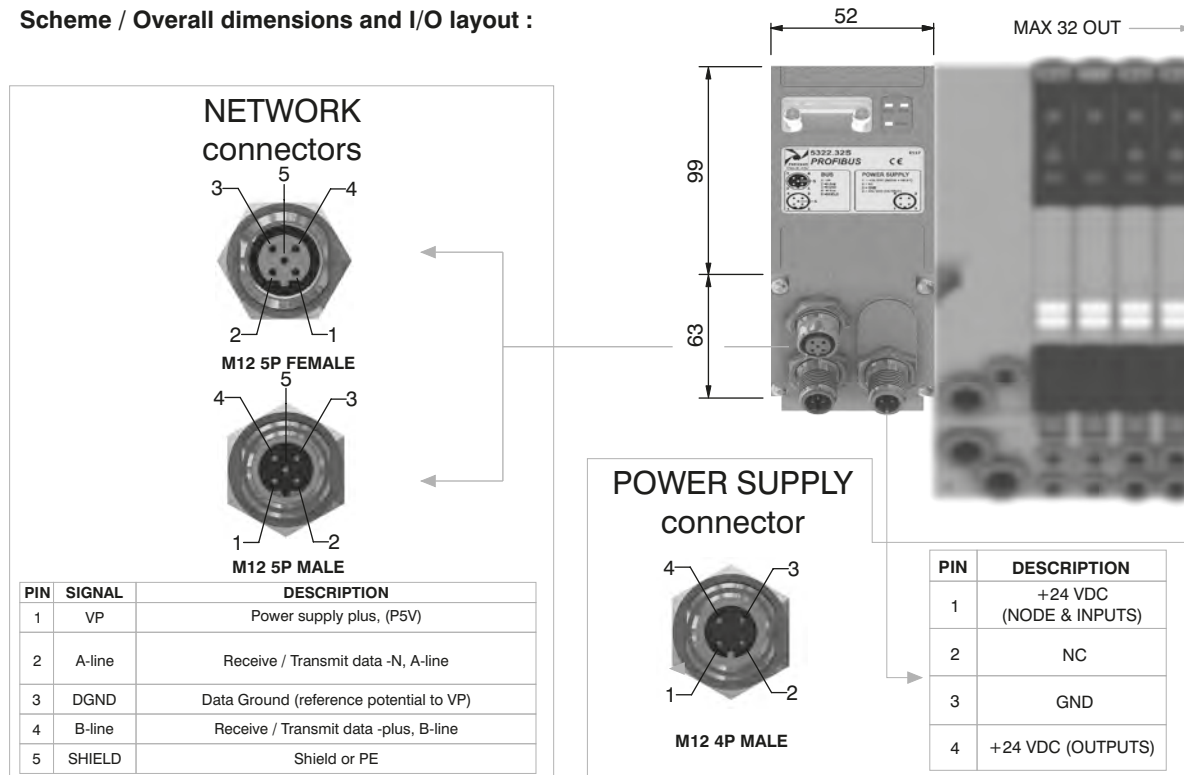

**Technical characteristics**

Model	5322.32S
Specifications	PROFIBUS DP
Case	Reinforced technopolymer
<b>Power supply</b>	Power supply connection M12 4P male connector (IEC 60947-5-2)
	Power supply voltage +24 VDC +/- 10%
	Node consumption (without inputs) 50 mA
	Power supply diagnosis Green LED PWR
<b>Outputs</b>	PNP equivalent outputs +24 VDC +/- 10%
	Maximum current for each output 100 mA
	Maximum output number 32
	Max output simultaneously actuated 32
<b>Network</b>	Network connectors 2 M12 5P male-female connectors Type B
	Baud rate 9,6 - 19,2 - 93,75 - 187,5 - 500 - 1500 - 3000 - 6000 - 12000 Kbit/s
	Addresses, possible numbers From 1 to 99
	Max nodes in net 100 (slave + master)
	Bus maximum recommended length 100 m at 12 Mbit/s - 1200 m at 9,6 Kbit/s
	Bus diagnosis Green LED + Red LED
	Configuration file Available from our web site: <a href="http://www.pneumaxspa.com">http://www.pneumaxspa.com</a>
	IP protection grade IP65 when assembled
	Temperature range From 0° to +50° C



**General:**

EtherCAT® module is directly integrated on Optyma-S solenoid valves manifold via a 37 poles connector, normally used for multipolar cable connection.  
Optyma-S solenoid valves connected to node must be PNP equivalent (final 02 in ordering code).

The node can be easily installed also on solenoid valves manifold already mounted on equipment.

Module can manage up to 32 solenoid valves, and, in the same time, a max number of 4 Input modules 5222.08S.

The EtherCAT® module, regardless the number of Input module connected, reports to have connected 4 Input modules.

Regardless of the number of Input modules connected, the manageable solenoid valves are 32.

Node power supply is made by a M12 4P male circular connector.

The separation between node 24 VDC Power supply and outputs 24 VDC allows to switch off the outputs maintaining powered the node and inputs, if present.

Connection to Bus EtherCAT® is possible via 2 M12 4P type D female circular connectors. These two connectors lead the signal to two different communication ports, so they are not connected in parallel.

The node address is assigned during configuration.

**Ordering code**

**5722.32S.EC.A**

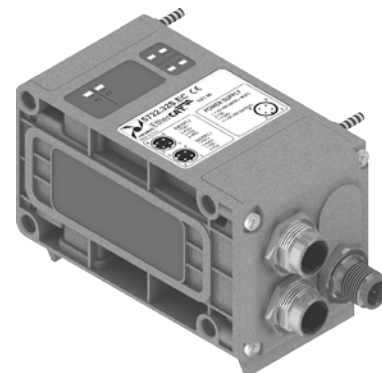

1  
AIR DISTRIBUTION

**Scheme / Overall dimensions and I/O layout :**

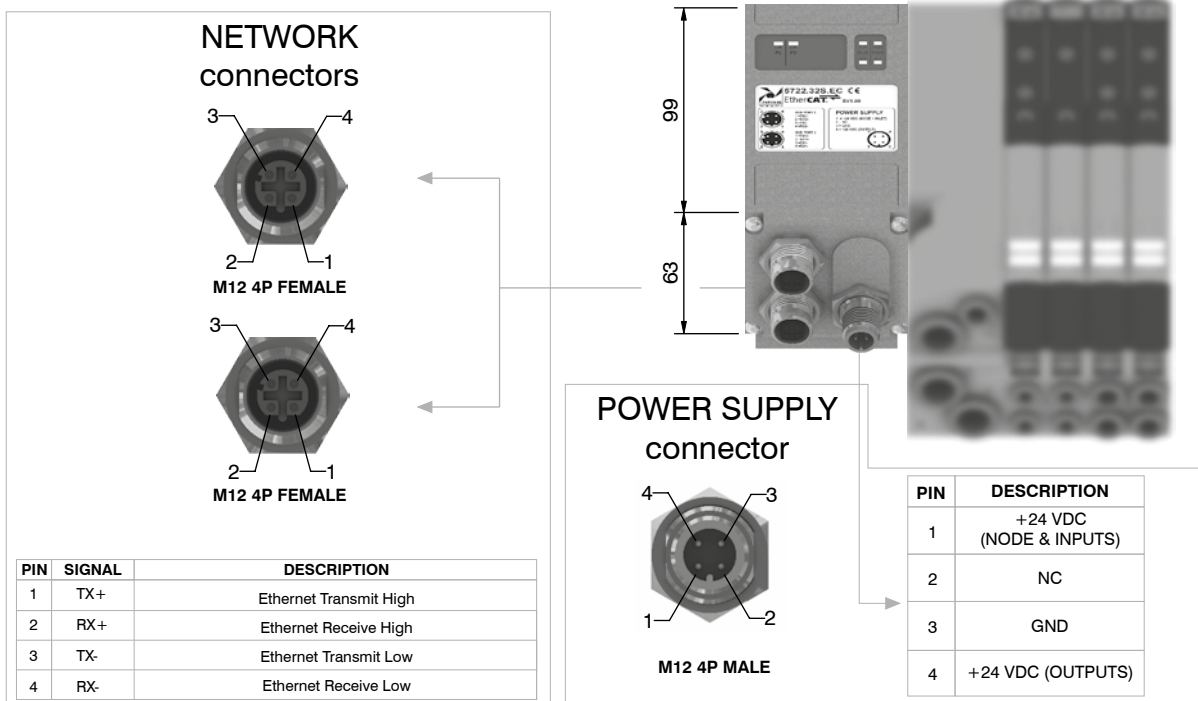

**Technical characteristics**

	Model	5722.32S.EC.A
	Specifications	EtherCAT® Specifications ETG.1000 series
	Case	Reinforced technopolymer
<b>Power supply</b>	Power supply connection	M12 4P male connector (IEC 60947-5-2)
	Power supply voltage	+24 VDC +/- 10%
	Node consumption (without inputs)	60 mA
	Power supply diagnosis	Green LED PWR / Green LED OUT
<b>Outputs</b>	PNP equivalent outputs	+24 VDC +/- 10%
	Maximum current for each output	100 mA
	Maximum output number	32
	Max output simultaneously actuated	32
<b>Network</b>	Network connectors	2 M12 4P female connectors Type D (IEC 61076-2-101)
	Baud rate	100 Mbit/s
	Addresses, possible numbers	From 1 to 65535
	Max nodes in net	65536 (Master + Slave)
	Maximum distance between 2 nodes	100 m
	Bus diagnosis	1 green and 1 red LED for status + 2 LEDs for link & activity
	Configuration file	Available from our web site: <a href="http://www.pneumaxspa.com">http://www.pneumaxspa.com</a>
	IP protection grade	IP65 when assembled
Temperature range	From 0° to +50° C	

**General:**

PROFINET IO RT module is directly integrated on Optyma-S solenoid valves manifold via a 37 poles connector, normally used for multipolar cable connection. Optyma-S solenoid valves connected to node must be PNP equivalent (final 02 in ordering code).

The node can be easily installed also on solenoid valves manifold already mounted on equipment.

Module can manage up to 32 solenoid valves, and, in the same time, a max number of 4 Input modules 5222.08S.

The PROFINET IO RT module, regardless the number of Input module connected, reports to have connected 8 Input modules.

Regardless of the number of Input modules connected, the manageable solenoid valves are 32.

Node power supply is made by a M12 4P male circular connector.

The separation between node 24 VDC Power supply and outputs 24 VDC allows to switch off the outputs maintaining powered the node and inputs, if present.

Connection to Bus PROFINET IO RT is possible via 2 M12 4P type D female circular connectors. These two connectors lead the signal to two different communication ports, so they are not connected in parallel.

The node address is assigned during configuration.

**Ordering code**

**5722.32S.PN.A**

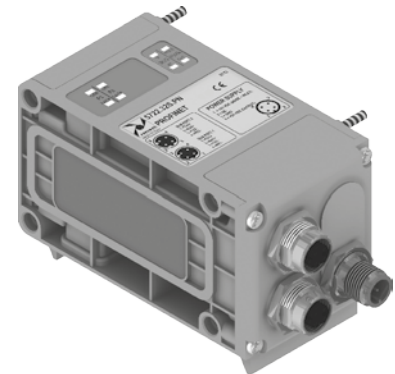

1 AIR DISTRIBUTION

**Scheme / Overall dimensions and I/O layout :**

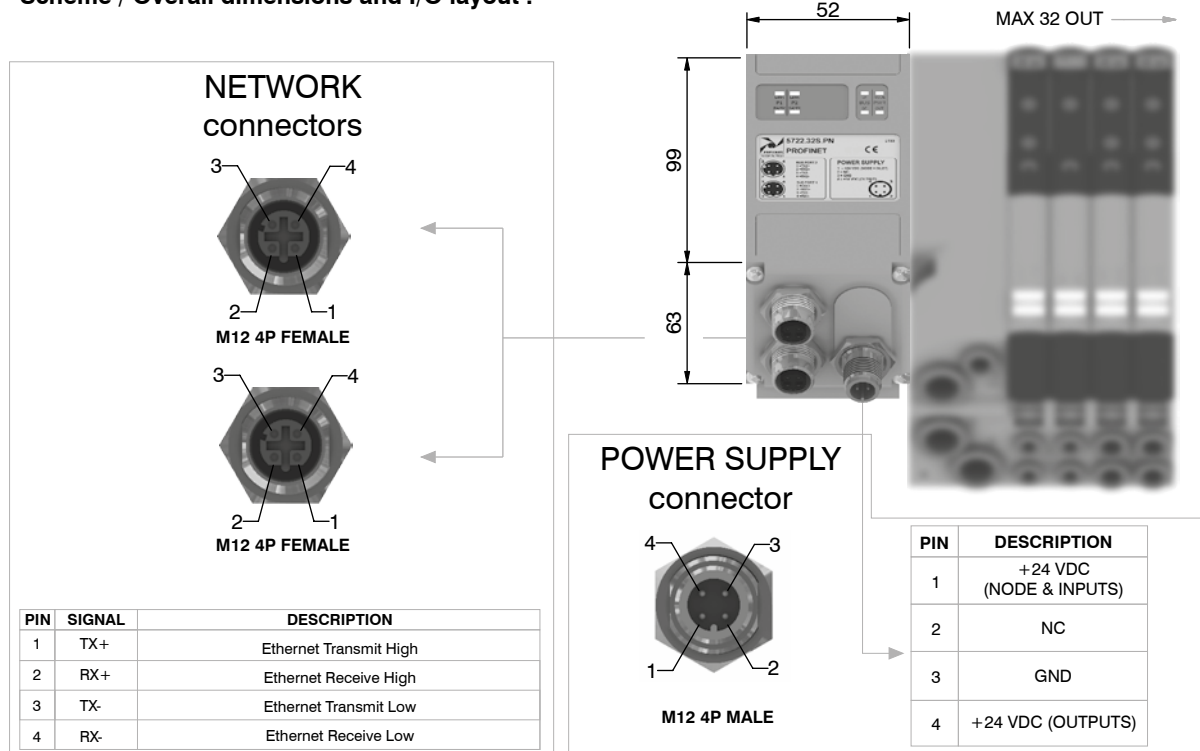

**Technical characteristics**

	Model	5722.32S.PN.A
	Specifications	PROFINET IO RT
	Case	Reinforced technopolymer
<b>Power supply</b>	Power supply connection	M12 4P male connector (IEC 60947-5-2)
	Power supply voltage	+24 VDC +/- 10%
	Node consumption (without inputs)	60 mA
	Power supply diagnosis	Green LED PWR / Green LED OUT
<b>Outputs</b>	PNP equivalent outputs	+24 VDC +/- 10%
	Maximum current for each output	100 mA
	Maximum output number	32
	Max output simultaneously actuated	32
<b>Network</b>	Network connectors	2 M12 4P female connectors Type D (IEC 61076-2-101)
	Baud rate	100 Mbit/s
	Max nodes in net	As an Ethernet Network
	Maximum distance between 2 nodes	100 m
	Bus diagnosis	2 red LED for status + 4 LEDs for link & activity
	Configuration file	Available from our web site: <a href="http://www.pneumaxspa.com">http://www.pneumaxspa.com</a>
	IP protection grade	IP65 when assembled
	Temperature range	From 0° to +50° C



**General:**

EtherNet/IP module is directly integrated on Optyima-S solenoid valves manifold via a 37 poles connector, normally used for multipolar cable connection.  
Optyima-S solenoid valves connected to node must be PNP equivalent (final 02 in ordering code).

The node can be easily installed also on solenoid valves manifold already mounted on equipment.

Module can manage up to 32 solenoid valves, and, in the same time, a max number of 4 Input modules 5222.08S.

The EtherNet/IP module, regardless the number of Input module connected, reports to have connected 8 Input modules.

Regardless of the number of Input modules connected, the manageable solenoid valves are 32.

Node power supply is made by a M12 4P male circular connector.

The separation between node 24 VDC Power supply and outputs 24 VDC allows to switch off the outputs maintaining powered the node and inputs, if present.

Connection to Bus EtherNet/IP is possible via 2 M12 4P type D female circular connectors. These two connectors lead the signal to two different communication ports, so they are not connected in parallel.

The node address is assigned during configuration.

**Ordering code**

**5722.32S.EI.A**



1  
AIR DISTRIBUTION

**Scheme / Overall dimensions and I/O layout :**

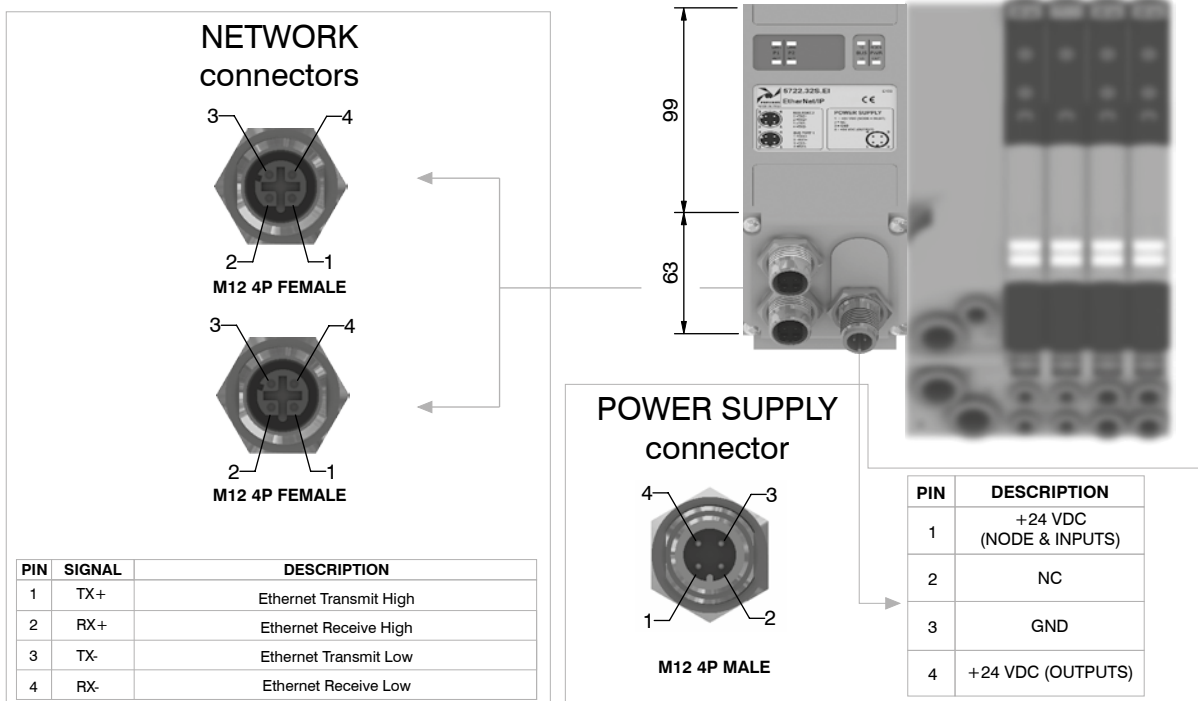

PIN	SIGNAL	DESCRIPTION
1	TX+	Ethernet Transmit High
2	RX+	Ethernet Receive High
3	TX-	Ethernet Transmit Low
4	RX-	Ethernet Receive Low

PIN	DESCRIPTION
1	+24 VDC (NODE & INPUTS)
2	NC
3	GND
4	+24 VDC (OUTPUTS)

**Technical characteristics**

	Model	5722.32S.EI.A
	Specifications	The EtherNet/IP Specification
	Case	Reinforced technopolymer
<b>Power supply</b>	Power supply connection	M12 4P male connector (IEC 60947-5-2)
	Power supply voltage	+24 VDC +/- 10%
	Node consumption (without inputs)	60 mA
	Power supply diagnosis	Green LED PWR / Green LED OUT
<b>Outputs</b>	PNP equivalent outputs	+24 VDC +/- 10%
	Maximum current for each output	100 mA
	Maximum output number	32
	Max output simultaneously actuated	32
<b>Network</b>	Network connectors	2 M12 4P female connectors Type D (IEC 61076-2-101)
	Baud rate	100 Mbit/s
	Max nodes in net	As an Ethernet Network
	Maximum distance between 2 nodes	100 m
	Bus diagnosis	2 bi-colors LED green/red for status + 4 LEDs for link & activity
	Configuration file	Available from our web site: <a href="http://www.pneumaxspa.com">http://www.pneumaxspa.com</a>
	IP protection grade	IP65 when assembled
	Temperature range	From 0° to +50° C

**General:**

CC-Link IE Field Basic module is directly integrated on Optyma-S solenoid valves manifold via a 37 poles connector, normally used for multipolar cable connection. Optyma-S solenoid valves connected to node must be PNP equivalent (final 02 in ordering code).

The node can be easily installed also on solenoid valves manifold already mounted on equipment.

Module can manage up to 32 solenoid valves, and, in the same time, a max number of 4 Input modules 5222.08S.

The CC-Link IE Field Basic module, regardless the number of Input module connected, reports to have connected 8 Input modules.

Regardless of the number of Input modules connected, the managable solenoid valves are 32.

Node power supply is made by a M12 4P male circular connector.

The separation between node 24 VDC Power supply and outputs 24 VDC allows to switch off the outputs maintaining powered the node and inputs, if present.

Connection to Bus CC-Link IE Field Basic is possible via 2 M12 4P type D female circular connectors. These two connectors lead the signal to two different communication ports, so they are not connected in parallel.

The node address is assigned during configuration.

**Ordering code**

5722.32S.CL.A

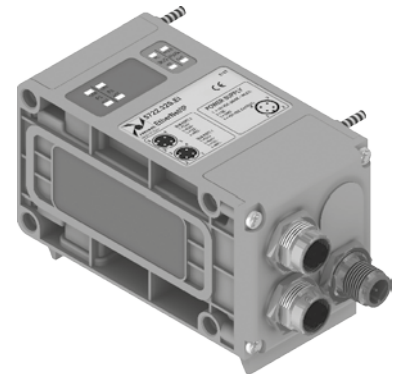

**Scheme / Overall dimensions and I/O layout :**

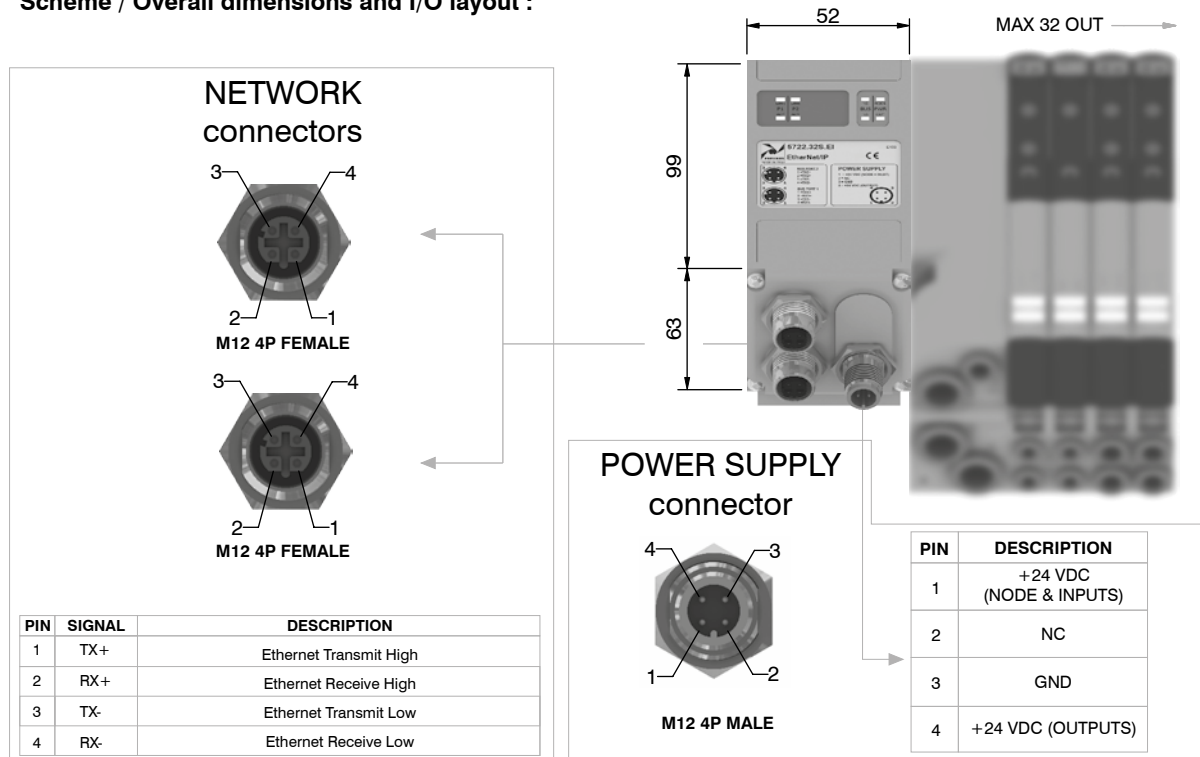

**Technical characteristics**

Model	5722.32S.CL.A
Specifications	CC-Link IE Field Basic Specification
Case	Reinforced technopolymer
<b>Power supply</b>	Power supply connection: M12 4P male connector (IEC 60947-5-2)
	Power supply voltage: +24 VDC +/- 10%
	Node consumption (without inputs): 60 mA
	Power supply diagnosis: Green LED PWR / Green LED OUT
<b>Outputs</b>	PNP equivalent outputs: +24 VDC +/- 10%
	Maximum current for each output: 100 mA
	Maximum output number: 32
	Max output simultaneously actuated: 32
<b>Network</b>	Network connectors: 2 M12 4P female connectors Type D (IEC 61076-2-101)
	Baud rate: 100 Mbit/s
	Max nodes in net: As an Ethernet Network
	Maximum distance between 2 nodes: 100 m
	Bus diagnosis: 1 green and 1 red LED for status + 2 LEDs for link & activity
	Configuration file: Available from our web site: <a href="http://www.pneumaxspa.com">http://www.pneumaxspa.com</a>
	IP protection grade: IP65 when assembled
	Temperature range: From 0° to +50° C

**General:**

IO-Link module is directly integrated on Optyma-S solenoid valves manifold via a 37 poles connector, normally used for multipolar cable connection.  
Optyma-S solenoid valves connected to node must be PNP equivalent (final 02 in ordering code).

The node can be easily installed also on solenoid valves manifold already mounted on equipment.

Module can manage up to 32 solenoid valves, and, in the same time, a max number of 4 Input modules 5222.08S.

Regardless of the number of Input modules connected, the manageable solenoid valves are 32.

Valve power supply will be provided through an external M12, 5 poles, A type connector, directly through the communication connector for Class B port option.

IO-Link module support the IO-Link communications speed COM2.

IODD configuration files will be provided by Pneumax.

**Ordering code**

**5822.32S**



1

AIR DISTRIBUTION

**Scheme / Overall dimensions and I/O layout :**

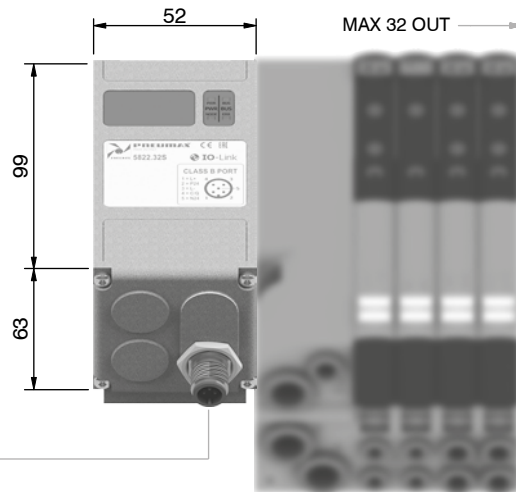
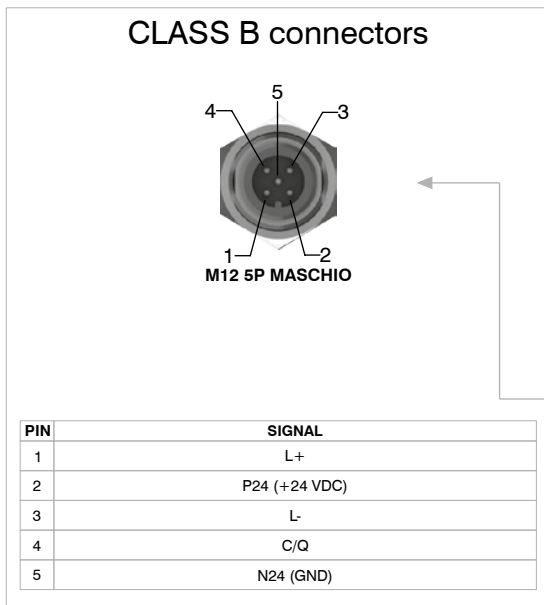

**Technical characteristics**

	Specifications	IO-Link Specification v1.1
	Case	Reinforced technopolymer
<b>Outputs</b>	PNP equivalent outputs	+24 VDC +/- 10%
	Maximum current for each output	100 mA
	Maximum output number	32
	Max output simultaneously actuated	32
	Network connectors	Class B ports
<b>Network</b>	Communication speed	COM 2
	Maximum distance from Master	20 m
	Vendor ID/Device ID	1257 (hex 0x04E9) / 5800 (hex 0x16A8)
	Bus diagnosis	1 green and 1 red LED for status
	Configuration file IODD	Available from our web site: <a href="http://www.pneumaxspa.com">http://www.pneumaxspa.com</a>
	IP protection grade	IP65 when assembled
	Temperature range	From 0° to +50° C

**General:**

Modules have 8 connectors M8 3P female.

The Inputs are PNP equivalent 24 VDC  $\pm 10\%$ .

To each connector it is possible to plug both 2 wires Inputs (switches, magnetic switches pressure switches, etc) or 3 wires Inputs (proximity, photocells, electronic sensors, etc).

The maximum current available for all 8 Inputs is 300 mA.

Each module includes a 300 mA self-mending fuse. If a short circuit or a overcharge (overall current  $>300\text{mA}$ ) occur the safety device acts cutting the 24 VDC power supply to all M8 connectors on the module and switching off the green LED PWR. Any other Input module connected to the node will remain powered and will function correctly.

Once the cause of the fault disappears the green LED PWR lights up indicating the ON state and the node will re-start to operate.

The maximum number of Input modules supported is 4.

**Ordering code**

**5222.08S**



**Scheme / Overall dimensions and I/O layout :**

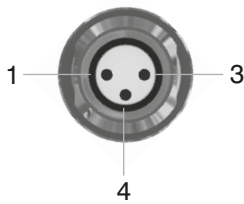
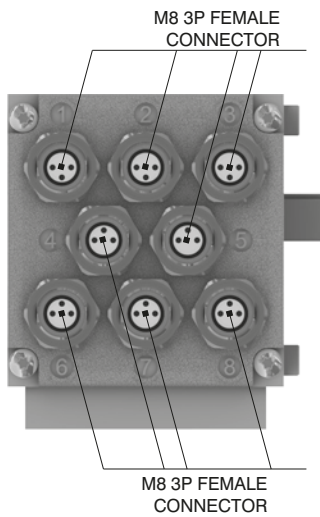

PIN	DESCRIPTION
1	+24 VDC
4	INPUT
3	GND

Module 1

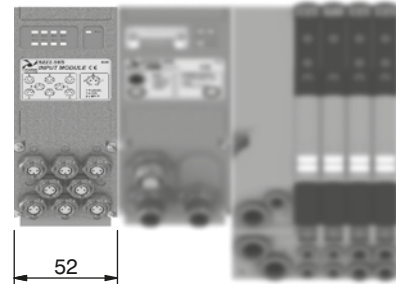

Module 2 Module 1

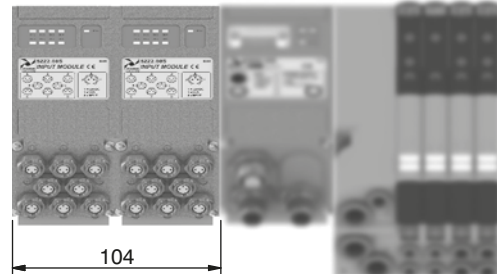

Module 3 Module 2 Module 1

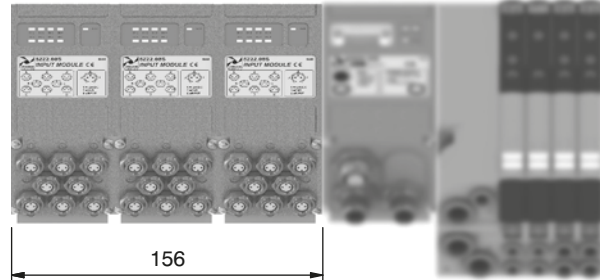

Module 4 Module 3 Module 2 Module 1

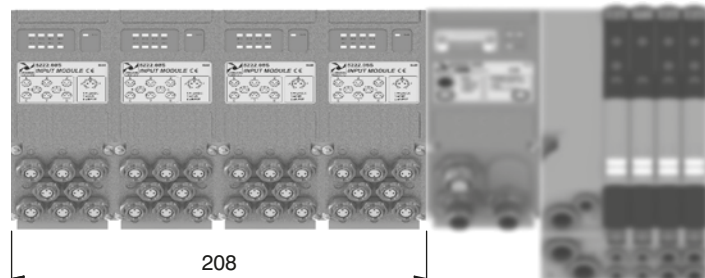





1  
AIR DISTRIBUTION

Socket for Power Supply  
STRAIGHT CONNECTOR  
M12A 4P FEMALE

Ordering code

5312A.F04.00



POWER SUPPLY connector

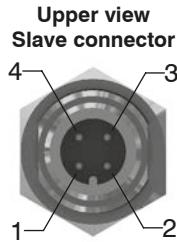

PIN	DESCRIPTION
1	+24 VDC Node
2	NC
3	GND
4	+24 VDC Outputs

Socket for Bus CANopen®/DeviceNet  
STRAIGHT CONNECTOR  
M12A 5P FEMALE

Ordering code

5312A.F05.00

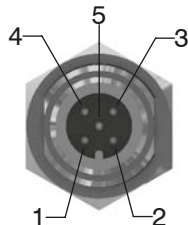

PIN	DESCRIPTION
1	(CAN_SHIELD)
2	(CAN_V+)
3	CAN_GND
4	CAN_H
5	CAN_L

Upper view  
Slave connector

NETWORK connectors

Plug for Bus CANopen®/DeviceNet  
STRAIGHT CONNECTOR  
M12A 5P MALE

Ordering code

5312A.M05.00

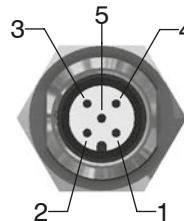

Plug for Bus EtherCAT®,  
PROFINET IO RT,  
EtherNet/IP and Powerlink  
STRAIGHT CONNECTOR M12D 4P MALE

Ordering code

5312D.M04.00



PIN	SIGNAL	DESCRIPTION
1	TX+	Ethernet Transmit High
2	RX+	Ethernet Receive High
3	TX-	Ethernet Transmit Low
4	RX-	Ethernet Receive Low

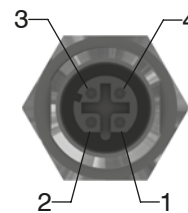

Upper view  
Slave connector

Socket for Bus PROFIBUS DP  
STRAIGHT CONNECTOR  
M12B 5P FEMALE

Ordering code

5312B.F05.00

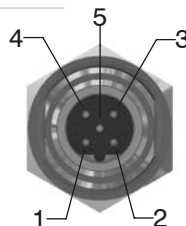

PIN	DESCRIPTION
1	Power Supply
2	A-line
3	DGND
4	B-line
5	SHIELD

Upper view  
Slave connector

Plug for Bus PROFIBUS DP  
STRAIGHT CONNECTOR  
M12B 5P MALE

Ordering code

5312B.M05.00

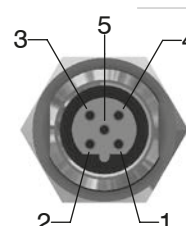

Plug for Input module  
STRAIGHT CONNECTOR  
M8 3P MALE

Ordering code

5308A.M03.00



INPUT connectors

Upper view  
Slave connector

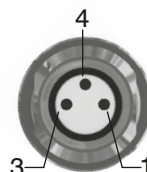

PIN	DESCRIPTION
1	+24 VDC
4	INPUT
3	GND

M12 plug

Ordering code

5300.T12



Plugs

M8 plug

Ordering code

5300.T08



Trademarks: EtherCAT® is registered trademark and patented technology, licensed by Beckhoff Automation GmbH, Germany.

Manifold Layout configuration with serial systems

1 AIR DISTRIBUTION

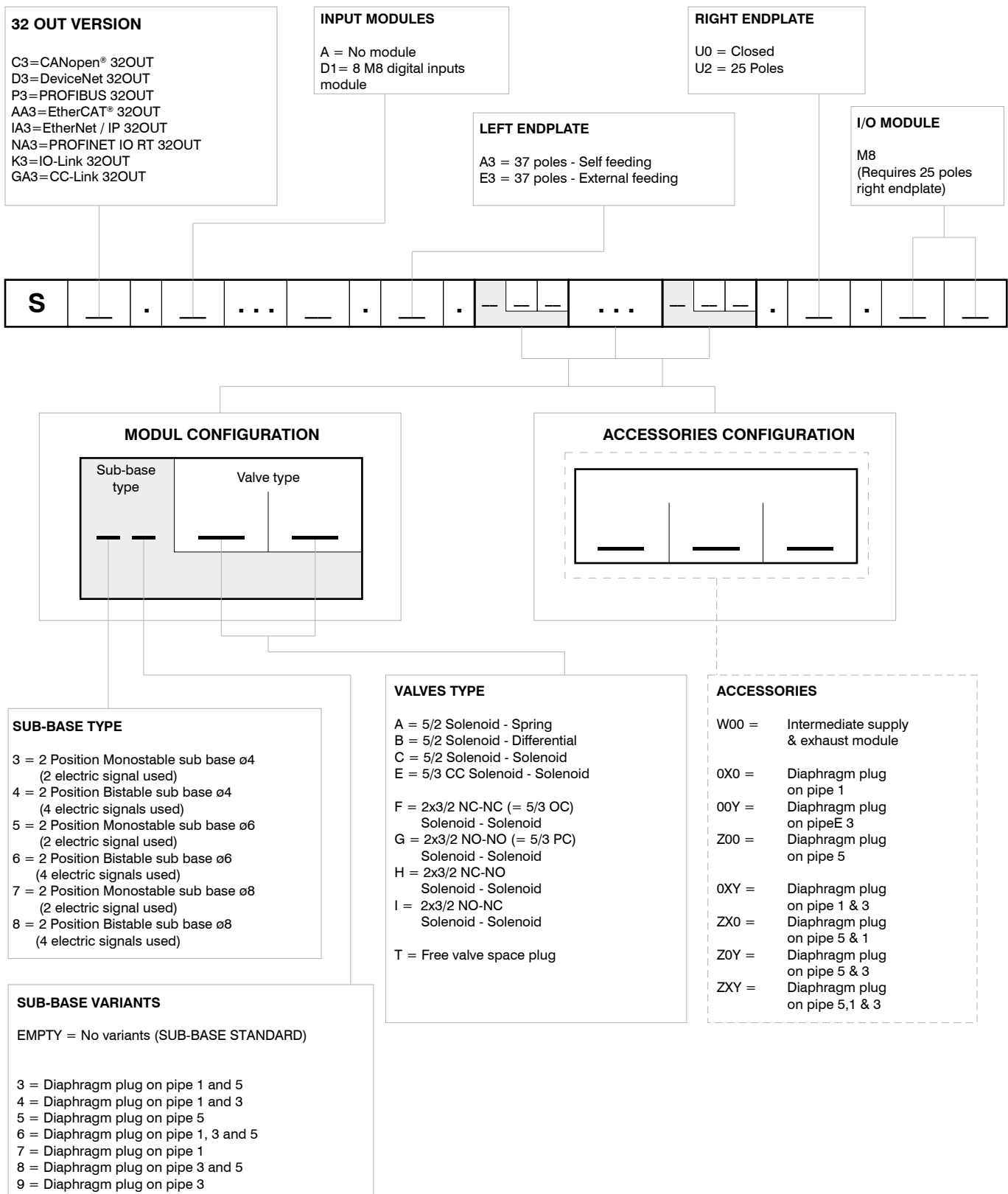

**NOTE:**  
 While configuring the manifold always be careful that the maximum number of electrical signals available is 32  
 The use of monostable valve mounted on a bistable base ( 2 electrical signals occupied for each position) causes the loss of one electric signal.  
 In this case the monostable valve can be replaced by a bistable valve without reconfiguring the PLC.  
 The diaphragms plugs are used to intercept the conduits 1,3 & 5 of the base.  
 Should one or more conduits be cut more than one time it is necessary to add the relevant intermediate Supply/Exhaust module.





## Series 2200 "OPTYMA-Sc"

### General

Optyma solenoid valves series it's completed by "Compact" version. It is useful in case a limited number of solenoid valves is needed without managing input and output signals. Standard base blocks provide 4 or 6 solenoid valves positions. Standard base blocks can be individually sold even without solenoid valves to allow maximum configuration flexibility.

Solenoid valves can be chosen from whole Optyma-S range.

Manifolds made in this way allow great room and weight saving against correspondent pneumatic group from Optyma-S series.

- Flow rate: up to 550[Nl/min], using the modular base with Ø8 quick fitting tube.
- Modular base available with Ø4, Ø6, Ø8 quick fitting tube.
- The solenoid pilots are low consumption and fitted on the same side of the valve.
- Mono and bistable valves have the same dimension.
- Easy and fast assembly on the sub base thanks to the "one screw" mounting solution.
- Possibility to replace a valve without the need of disconnecting the pneumatic pipes.
- Electrical and pneumatic connections positioned on the same side.
- Possibility to operate with different pressures and vacuum.
- 4 or 6 electric signals management (two signals per position, independently of the mounted solenoid valve).
- The electrical connection is achieved thanks to a 9 or 15 poles connector.
- The protection grade is IP65 directly integrated in the manifold components.

**"Shifting time of pneumatic directional control valves or moving parts, logic devices were measured in accordance to ISO 12238:2001, Pneumatic fluid power-Directional control valves-Measurement of shifting time"**

### Main characteristics

One size: 12.5mm thick  
Monostable and bistable valves with same dimensions  
Modular subbase with two positions  
Quick coupling connections directly integrated in sub base  
Integrated and optimized electrical connection system.  
IP65 protection grade as standard

### Construction characteristics

Body	Technopolymer
Spacer	Technopolymer
Spacers	NBR
Piston seals	NBR
Springs	AISI 303 stainless steel
Operators	Technopolymer
Pistons	Technopolymer
Spools	AISI 303 stainless steel

### Functions

SV 5/2 MONOSTABLE SOLENOID-SPRING  
SV 5/2 MONOSTABLE SOLENOID-DIFFERENTIAL  
SV 5/2 BISTABLE SOLENOID-SOLENOID  
SV 5/3 C.C. SOLENOID-SOLENOID  
SV 2x3/2 N.C.-N.C. (=5/3 O.C.) SOLENOID-SOLENOID  
SV 2x3/2 N.O.-N.O. (=5/3 P.C.) SOLENOID-SOLENOID  
SV 2x3/2 N.C.-N.O. SOLENOID-SOLENOID  
SV 2x3/2 N.O.-N.C. SOLENOID-SOLENOID

### Technical characteristics

Voltage	24VDC ±10% PNP (NPN and AC on request)
Pilot consumption	0,5 Watt
Pilot working pressure (12-14)	from 2,5 to 7 bar max.
Valve working pressure [1]	from vacuum to 10 bar max.
Operating temperature	from -5°C to +50°C
Protection degree	IP40
Life (standard operating conditions)	50000000
Fluid	Filtered air. No lubrication needed, if applied it shall be continuous

1  
AIR DISTRIBUTION

### Solenoid - Spring

Coding: 2241.52.00.39.

Operational characteristics	
Fluid	Filtered air. No lubrication needed, if applied it shall be continuous
Working pressure (bar)	From vacuum to 10
Pressure range (bar)	2,5 ÷ 7
Temperature °C	-5 ÷ +50
Flow rate at 6 bar with $\Delta p=1$ (NI/min)	550
Response time according to ISO 12238, activation time (ms)	12
Response time according to ISO 12238, deactivation time (ms)	20

	VOLTAGE
	02 = 24 VDC PNP
SHORT FUNCTION CODE "A"	
Weight 67 g	

Shifting time of pneumatic directional control valves or moving parts, logic devices were measured in accordance to ISO 12238:2001

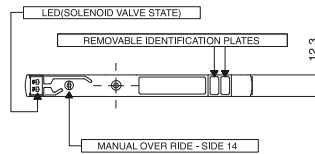
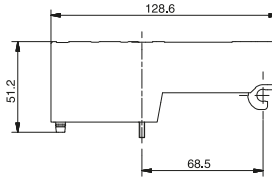
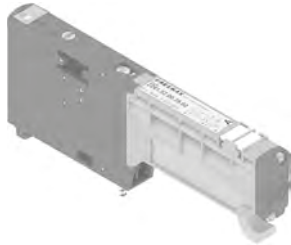

Flow rate at 6 bar with  $\Delta p=1$  (NI/min) with Base cod. 2248.01 tube  $\varnothing 8= 550$



### Solenoid-Differential

Coding: 2241.52.00.36.

Operational characteristics	
Fluid	Filtered air. No lubrication needed, if applied it shall be continuous
Working pressure (bar)	From vacuum to 10
Pressure range (bar)	2,5 ÷ 7
Temperature °C	-5 ÷ +50
Flow rate at 6 bar with $\Delta p=1$ (NI/min)	550
Response time according to ISO 12238, activation time (ms)	20
Response time according to ISO 12238, deactivation time (ms)	25

	VOLTAGE
	02 = 24 VDC PNP
SHORT FUNCTION CODE "B"	
Weight 67 g	

Shifting time of pneumatic directional control valves or moving parts, logic devices were measured in accordance to ISO 12238:2001

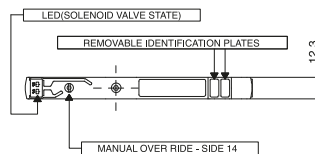
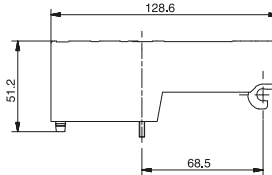
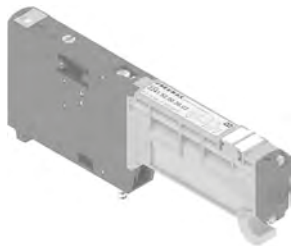

Flow rate at 6 bar with  $\Delta p=1$  (NI/min) with Base cod. 2248.01 tube  $\varnothing 8= 550$



### Solenoid-Solenoid

Coding: 2241.52.00.35.

Operational characteristics	
Fluid	Filtered air. No lubrication needed, if applied it shall be continuous
Working pressure (bar)	From vacuum to 10
Pressure range (bar)	2,5 ÷ 7
Temperature °C	-5 ÷ +50
Flow rate at 6 bar with $\Delta p=1$ (NI/min)	550
Response time according to ISO 12238, activation time (ms)	10
Response time according to ISO 12238, deactivation time (ms)	10

	VOLTAGE
	02 = 24 VDC PNP
SHORT FUNCTION CODE "C"	
Weight 67 g	

Shifting time of pneumatic directional control valves or moving parts, logic devices were measured in accordance to ISO 12238:2001

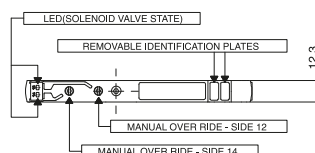
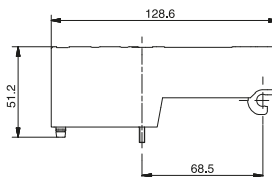
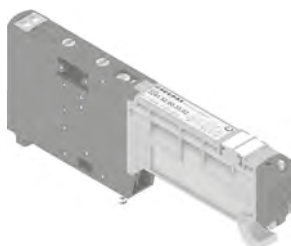

Flow rate at 6 bar with  $\Delta p=1$  (NI/min) with Base cod. 2248.01 tube  $\varnothing 8= 550$

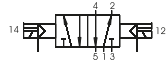



**Solenoid-Solenoid 5/3 (Closed centres)**

Coding: 2241.53.31.35. **V**

Operational characteristics	
Fluid	Filtered air. No lubrication needed, if applied it shall be continuous
Working pressure (bar)	From vacuum to 10
Pressure range (bar)	2,5 ÷ 7
Temperature °C	-5 ÷ +50
Flow rate at 6 bar with Δp=1 (NI/min)	400
Response time according to ISO 12238, activation time (ms)	15
Response time according to ISO 12238, deactivation time (ms)	20

<b>V</b>	VOLTAGE
	02 = 24 VDC PNP
SHORT FUNCTION CODE "E"	
Weight 83 g	

Shifting time of pneumatic directional control valves or moving parts, logic devices were measured in accordance to ISO 12238:2001

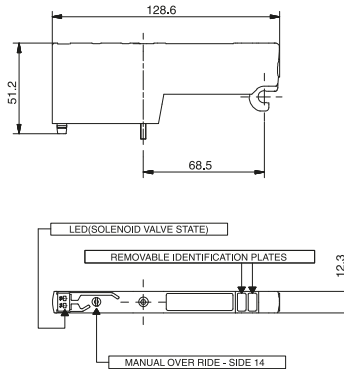
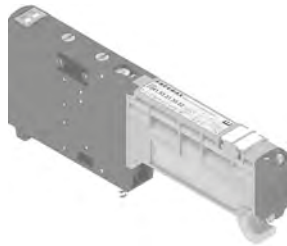

Flow rate at 6 bar with Δp=1 (NI/min) with Base cod. 2248.01. **V** tube Ø8= 400

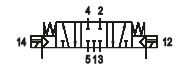

**Solenoid-Solenoid 2x3/2**

Coding: 2241.62. **F**.35. **V**

Operational characteristics	
Fluid	Filtered air. No lubrication needed, if applied it shall be continuous
Working pressure (bar)	From vacuum to 10
Pressure range (bar)	≥3+(0,2xInlet pressure)
Temperature °C	-5 ÷ +50
Flow rate at 6 bar with Δp=1 (NI/min)	420
Response time according to ISO 12238, activation time (ms)	15
Response time according to ISO 12238, deactivation time (ms)	25

<b>F</b>	FUNCTION
	44 = NC-NC (5/3 Open centres)
	45 = NC-NO (normally closed-normally open)
	54 = NO-NC (normally open-normally closed)
	55 = NO-NO (5/3 Pressured centres)
<b>V</b>	VOLTAGE
	02 = 24 VDC PNP

Shifting time of pneumatic directional control valves or moving parts, logic devices were measured in accordance to ISO 12238:2001

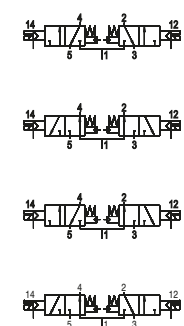
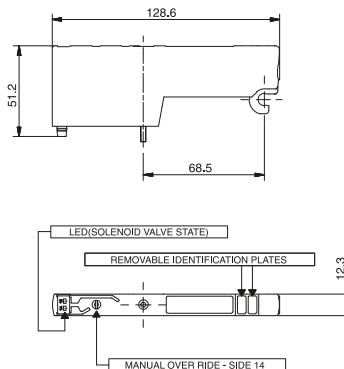
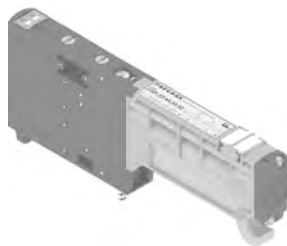

Flow rate at 6 bar with Δp=1 (NI/min) with Base cod. 2244.01. **F** tube Ø4= 140  
Flow rate at 6 bar with Δp=1 (NI/min) with Base cod. 2246.01. **F** tube Ø6= 360  
Flow rate at 6 bar with Δp=1 (NI/min) with Base cod. 2248.01. **F** tube Ø8= 420

Bases only kit

Coding: CMPVCP0

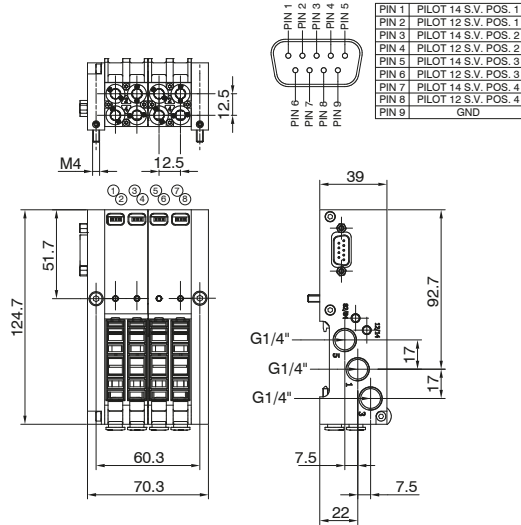

VERSION	
✓ 9E	= 9 poles kit
1E	= 15 poles kit
TUBE DIAMETER	
44	= Ø4-4 (9 poles)
66	= Ø6-6 (9 poles)
✓ 88	= Ø8-8 (9 poles)
444	= Ø4-4-4 (15 poles)
666	= Ø6-6-6 (15 poles)
888	= Ø8-8-8 (15 poles)

Weight 400 g CMP9ECP0

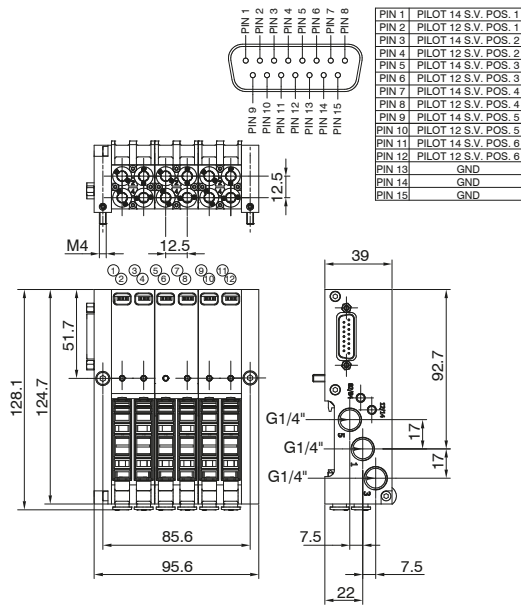

Weight 500 g CMP1ECP0

Available bases

Tube Ø4

Tube Ø6

Tube Ø8

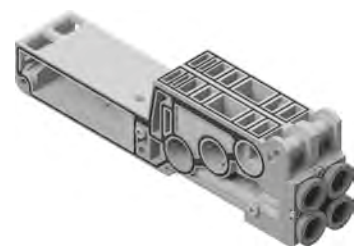



▶ Closing plate

Coding: 2240.00

Operational characteristics

Fluid	Filtered air. No lubrication needed, if applied it shall be continuous
Working pressure (bar)	From vacuum to 10
Temperature °C	-5 ÷ +50

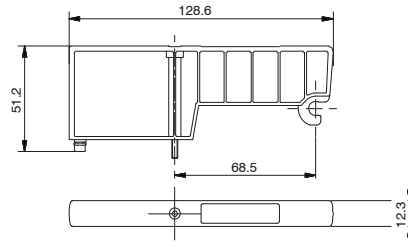

Weight 30 g  
SHORT FUNCTION CODE "T"

1  
AIR DISTRIBUTION

▶ Cable complete with connector, 9 Poles, IP40

Coding: 2400.09.●.00



	CABLE LENGTH
●	03 = 3 meters
	05 = 5 meters
	10 = 10 meters

▶ Cable complete with connector, 15 Poles, IP40

Coding: 2400.15.●.00



	CABLE LENGTH
●	03 = 3 meters
	05 = 5 meters
	10 = 10 meters





Manifold layout configuration

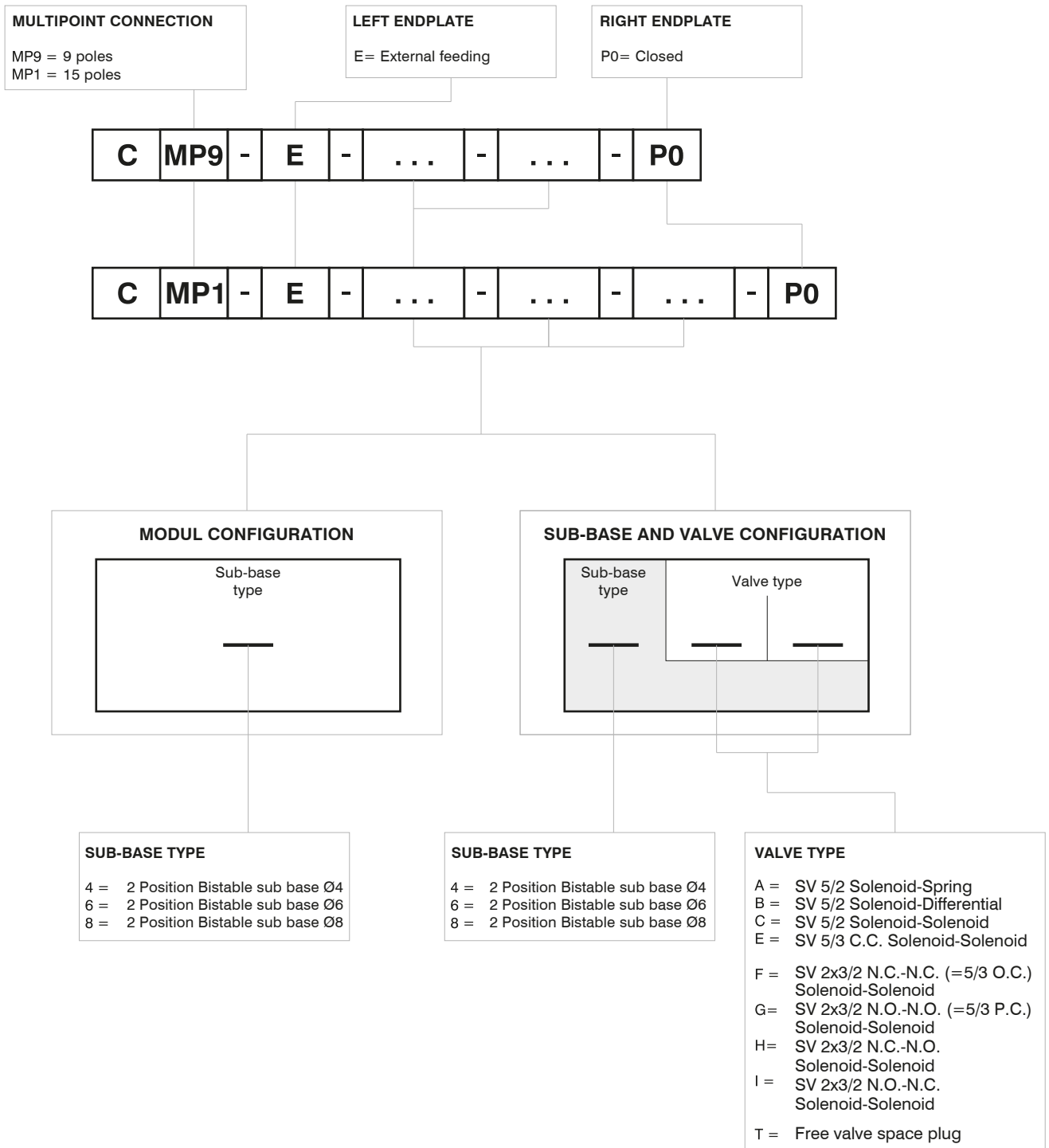

1  
AIR DISTRIBUTION

**Series 2200 OPTYMA-Sc solenoid valve manifolds managed by multipoint connection are "well tried components"**

	<b>Well-tryed component</b>	<ul style="list-style-type: none"> <li>- The product is well-tryed product for a safety-related application according to ISO 13849-1.</li> <li>- The relevant basic and well-tryed safety principles according ISO 13849-2 for this product are fulfilled.</li> <li>- The suitability of the product for a precise application must be verified and confirmed by the user.</li> </ul>
<b>B<sub>10d</sub></b>	50.000.000	



**Example shown : CMP9E68P0**  
Manifold with external supply, 9 poles multipolar, base Ø6, base Ø8



To be completed with solenoid valves before use



**Example shown : CMP1E666P0**  
Manifold with external supply, 15 poles multipolar, base Ø6, base Ø6, base Ø6



To be completed with solenoid valves before use



**Example shown : CMP1E6CA6CC6FFP0**  
Manifold with external supply, 15 poles multipolar, base Ø6 with solenoid valves, base Ø6 with solenoid valves, base Ø6 with solenoid valves



Two signals per position, independently of the mounted solenoid valve



**Example shown : CMP9E6TF6ACP0**  
Manifold with external supply, 9 poles multipolar, base Ø6 with solenoid valves, base Ø6 with solenoid valves



Two signals per position, independently of the mounted solenoid valve

**Supply ports and maximum possible size according to valves used**

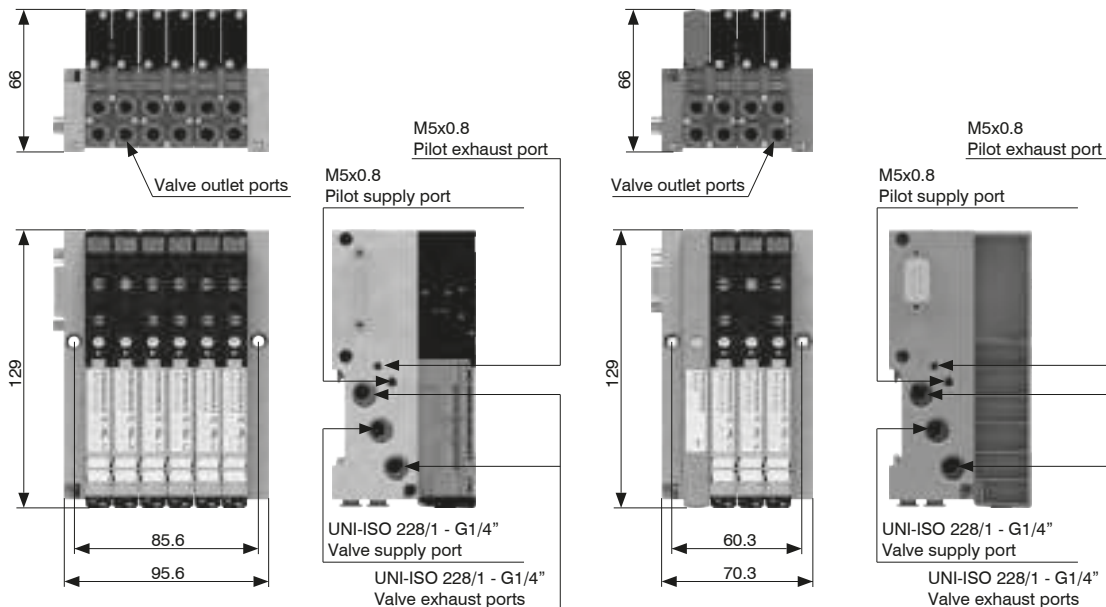



## Series 2500 "OPTYMA-F"

### General

The solenoid valves base mounted line including electrical connection into the manifold.  
Many technical features make the new product interesting:

- Flow rate of 1000 Nl/min
- Low consumption coils placed all in one side of the valve
- Quick mounting of the valve to the base using just one screw
- Quick connection of the bases thanks to 180 degree rotating pins
- Possibility to use different pressures along the manifold (including vacuum)
- IP65 environmental protection
- Electrical connection directly integrated into the base, 32 electrical signals available (can be used to build up a manifold of 32 monostable valves, 16 bistable valves or any combination within that limit).
- The electrical connection is made via 37 pin D-SUB connector.
- It is also available a 25-pole connector that is able to manage a maximum number of 22 electrical signals.

Possibility to integrate with Field Bus modules CANopen®, PROFIBUS DP, DeviceNet, EtherNet/IP, PROFINET IO RT/IRT, EtherCAT®, Powerlink and Modbus/TCP.

Possibility to connect input modules, even on the base that does not have the Field Bus module. Large use of technopolymer material reduces the overall weight of the manifold.

**"Shifting time of pneumatic directional control valves or moving parts, logic devices were measured in accordance to ISO 12238:2001, Pneumatic fluid power-Directional control valves-Measurement of shifting time"**

### Main characteristics

Integrated and optimized electrical connection system.  
IP65 protection degree.  
Only one 19mm size  
Electrical line connections on one side  
Monostable and bistable solenoid valves with the same size dimensions.  
Easy and fast manifold assembly

### Construction characteristics

Body	Technopolymer
Operators	Technopolymer
Spacers	NBR
Spacer	Technopolymer
Spools	Nickel - plated steel / Technopolymer
Springs	AISI 302 stainless steel
Pistons	Technopolymer
Piston seals	NBR

### Functions

SV 5/2 MONOSTABLE SOLENOID-SPRING  
SV 5/2 MONOSTABLE SOLENOID-DIFFERENTIAL  
SV 5/2 BISTABLE SOLENOID-SOLENOID  
SV 5/3 C.C. SOLENOID-SOLENOID  
SV 2x3/2 N.C.-N.C. (=5/3 O.C.) SOLENOID-SOLENOID  
SV 2x3/2 N.O.-N.O. (=5/3 P.C.) SOLENOID-SOLENOID  
SV 2x3/2 N.C.-N.O. SOLENOID-SOLENOID

### Technical characteristics

Voltage	24VDC ±10% PNP (NPN and AC on request)
Pilot consumption	1,3 Watt
Pilot working pressure (12-14)	From 3 to 7 bar max.
Valve working pressure [1]	from vacuum up to 10 bar
Operating temperature	-5°C +50°C
Protection degree	IP65
Life (standard operating conditions)	50000000
Fluid	Filtered air. No lubrication needed, if applied it shall be continuous



1  
AIR DISTRIBUTION

**Solenoid - Spring**

**Coding:** 2531.52.00.39. ✓

Operational characteristics	
Fluid	Filtered air. No lubrication needed, if applied it shall be continuous
Working pressure (bar)	From vacuum to 10
Pressure range (bar)	3 ÷ 7
Temperature °C	-5 ÷ +50
Flow rate at 6 bar with Δp=1 (NI/min)	1000
Response time according to ISO 12238, activation time (ms)	14
Response time according to ISO 12238, deactivation time (ms)	40

VOLTAGE
02 = 24 VDC PNP
12 = 24 VDC NPN
05 = 24 VAC

SHORT FUNCTION CODE "A"  
Weight 123 g

*Shifting time of pneumatic directional control valves or moving parts, logic devices were measured in accordance to ISO 12238:2001*

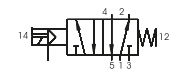
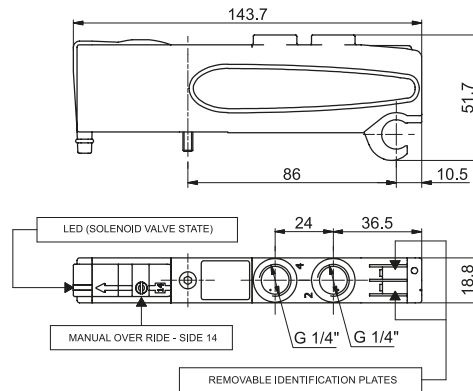

**Solenoid-Differential**

**Coding:** 2531.52.00.36. ✓

Operational characteristics	
Fluid	Filtered air. No lubrication needed, if applied it shall be continuous
Working pressure (bar)	From vacuum to 10
Pressure range (bar)	3 ÷ 7
Temperature °C	-5 ÷ +50
Flow rate at 6 bar with Δp=1 (NI/min)	1000
Response time according to ISO 12238, activation time (ms)	20
Response time according to ISO 12238, deactivation time (ms)	29

VOLTAGE
02 = 24 VDC PNP
12 = 24 VDC NPN
05 = 24 VAC

SHORT FUNCTION CODE "B"  
Weight 120 g

*Shifting time of pneumatic directional control valves or moving parts, logic devices were measured in accordance to ISO 12238:2001*

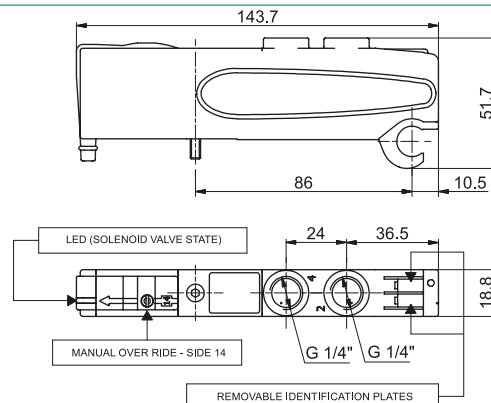

**Solenoid-Solenoid**

**Coding:** 2531.52.00.35. ✓

Operational characteristics	
Fluid	Filtered air. No lubrication needed, if applied it shall be continuous
Working pressure (bar)	From vacuum to 10
Pressure range (bar)	3 ÷ 7
Temperature °C	-5 ÷ +50
Flow rate at 6 bar with Δp=1 (NI/min)	1000
Response time according to ISO 12238, activation time (ms)	10
Response time according to ISO 12238, deactivation time (ms)	14

VOLTAGE
02 = 24 VDC PNP
12 = 24 VDC NPN
05 = 24 VAC

SHORT FUNCTION CODE "C"  
Weight 128 g

*Shifting time of pneumatic directional control valves or moving parts, logic devices were measured in accordance to ISO 12238:2001*

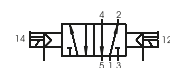
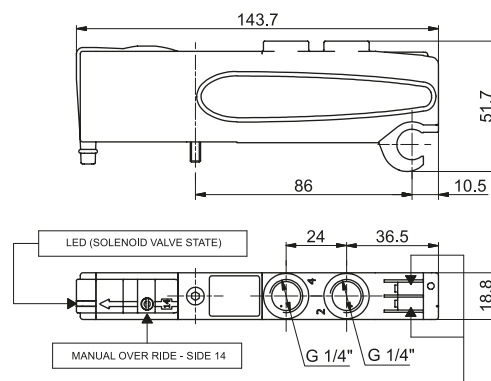

**Solenoid-Solenoid 5/3**

Coding: 2531.53.31.35. **V**

Operational characteristics	
Fluid	Filtered air. No lubrication needed, if applied it shall be continuous
Working pressure (bar)	From vacuum to 10
Pressure range (bar)	3 ÷ 7
Temperature °C	-5 ÷ +50
Flow rate at 6 bar with Δp=1 (NI/min)	600
Response time according to ISO 12238, activation time (ms)	15
Response time according to ISO 12238, deactivation time (ms)	20

VOLTAGE
<b>02</b> = 24 VDC PNP
<b>12</b> = 24 VDC NPN
<b>05</b> = 24 VAC

SHORT FUNCTION CODE "E"  
Weight 126 g

Shifting time of pneumatic directional control valves or moving parts, logic devices were measured in accordance to ISO 12238:2001

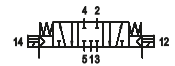
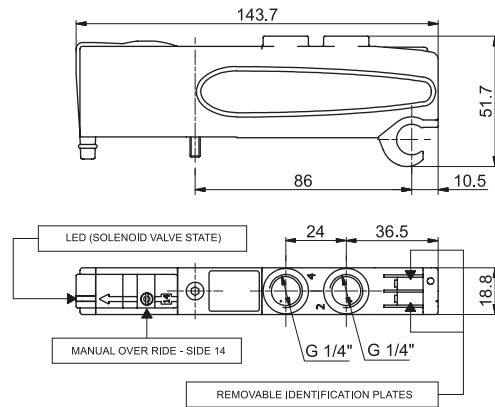

**Solenoid-Solenoid 2x3/2**

Coding: 2531.62. **F**.35. **V**

Operational characteristics	
Fluid	Filtered air. No lubrication needed, if applied it shall be continuous
Working pressure (bar)	From vacuum to 10
Pressure range (bar)	≥2,5+ (0,2xP.alim.)
Temperature °C	-5 ÷ +50
Flow rate at 6 bar with Δp=1 (NI/min)	700
Response time according to ISO 12238, activation time (ms)	15
Response time according to ISO 12238, deactivation time (ms)	25

FUNCTION
<b>44</b> = NC-NC (5/3 Open centres)
<b>55</b> = NO-NO (5/3 Pressured centres)
<b>45</b> = N.C.-N.O. (normally closed-normally open)
<b>54</b> = N.O.-N.C. (normally open-normally closed)
VOLTAGE
<b>02</b> = 24 VDC PNP
<b>12</b> = 24 VDC NPN
<b>05</b> = 24 VAC

SHORT FUNCTION CODE:  
NC-NC (5/3 Open centres) = "F"  
NO-NO (5/3 Pressured centres) = "G"  
NC-NO = "H"  
NO-NC = "I"  
Weight 115,5 g

Shifting time of pneumatic directional control valves or moving parts, logic devices were measured in accordance to ISO 12238:2001

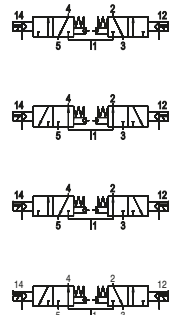
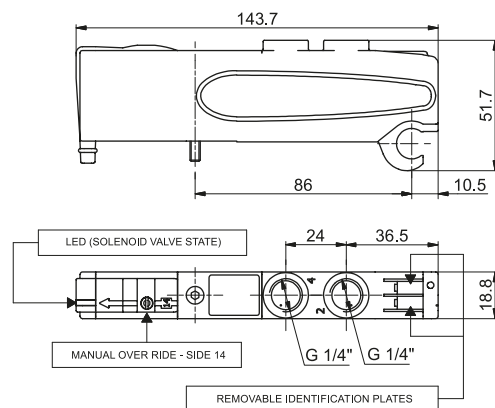



Left Endplates

Coding: 2530.V.C

Operational characteristics	
Fluid	Filtered air. No lubrication needed, if applied it shall be continuous
Working pressure (bar)	From vacuum to 10 (External pilot base only)
Pressure range (bar)	3 ÷ 7
Temperature °C	-5 ÷ +50

VERSION	
V	02 = External feeding
	12 = Self-feeding
ELECTRICAL CONNECTION	
37P	= Connectors 37 poles
PNP	
25P	= Connectors 25 poles
PNP	
37N	= Connectors 37 poles
NPN	
C	25N = Connectors 25 poles
NPN	
37A	= Connectors 37 poles
AC	
25A	= Connectors 25 poles
AC	
C16	= Terminal 16 signals
PNP	

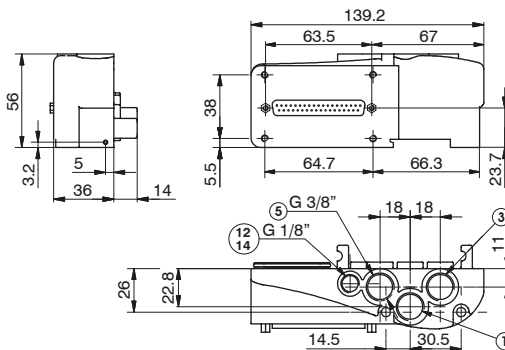

Weight 206 g

2530.02.C

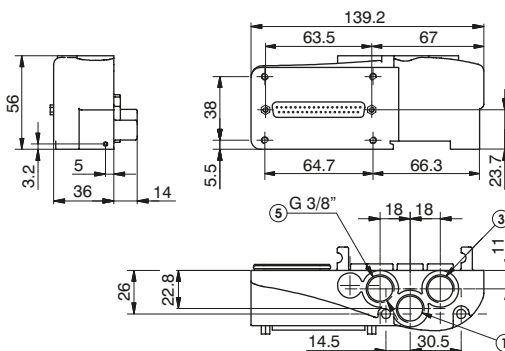
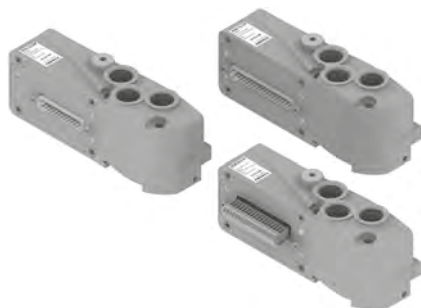

Weight 206 g

2530.12.C

Right Endplates

Coding: 2530.03.C

Operational characteristics	
Fluid	Filtered air. No lubrication needed, if applied it shall be continuous
Working pressure (bar)	From vacuum to 10
Temperature °C	-5 ÷ +50

ELECTRICAL CONNECTION	
C	00 = Electrical connection
25P	= Connectors 25 poles

Weight 181,5 g

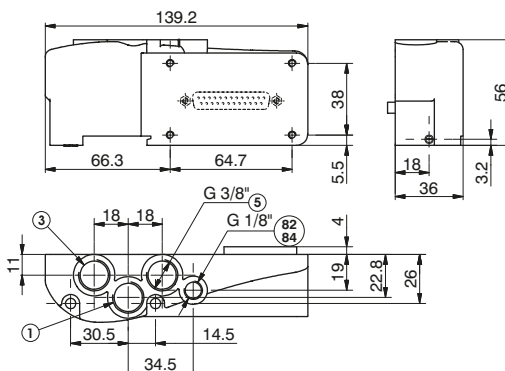

PORT 82/84= DO NOT PRESSURIZE, SOLENOID PILOTS EXHAUST

AIR DISTRIBUTION

1

**Closing plate**

Coding: 2530.00

Operational characteristics	
Fluid	Filtered air. No lubrication needed, if applied it shall be continuous
Working pressure (bar)	From vacuum to 10
Temperature °C	-5 ÷ +50

SHORT FUNCTION CODE "T"  
Weight 53,5 g

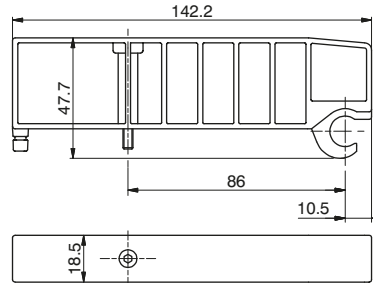

**Modular base**

Coding: 2530.01

Operational characteristics	
Fluid	Filtered air. No lubrication needed, if applied it shall be continuous
Working pressure (bar)	From vacuum to 10
Temperature °C	-5 ÷ +50

VERSION	
<b>M</b>	= for Monostable SV
<b>B</b>	= for Bistable SV

SHORT CODE "1" (per EV Monostabile)  
SHORT CODE "2" (per EV Bistabile)  
Weight 91,5 g

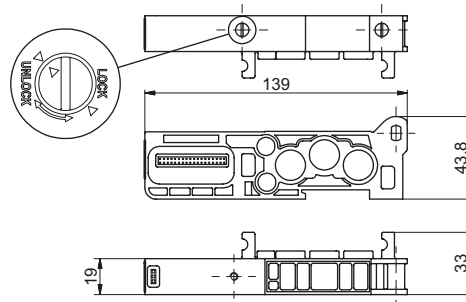

**Intermediate Inlet/Exhaust module**

Coding: 2530.10

Operational characteristics	
Fluid	Filtered air. No lubrication needed, if applied it shall be continuous
Working pressure (bar)	From vacuum to 10
Temperature °C	-5 ÷ +50

SHORT FUNCTION CODE "W"  
Weight 110 g

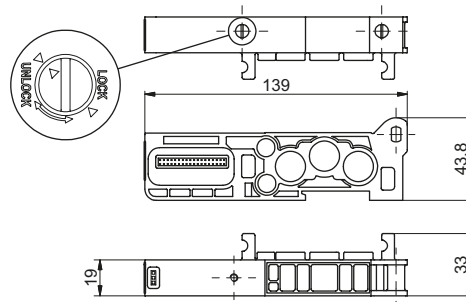

1  
AIR DISTRIBUTION

**General :**

Each Optyma-F manifold lets to manage 32 command signals for the valves. Optyma-F serial nodes (CANopen®, DeviceNet, PROFIBUS DP, EtherCAT®, PROFINET IO RT, EtherNet/IP and Powerlink) have a single pin for the power supply of the solenoid valves. So if you want to interrupt the power supply of one valve it is necessary to interrupt all the valves. The additional power supply module lets to interrupt at the same time the first 2/4/6/8 available command signals for the valves after the module itself. The additional power supply module is particularly useful also when you use control signals that block the valves. This application is effective both with serial management and multi-pole connection of the manifolds. This module has the same characteristics of an intermediate supply and exhaust module and fits directly into the Optyma-F series solenoid valve manifolds.

**Ordering code**

- 2530.10.2A = 2 positions
- 2530.10.4A = 4 positions
- 2530.10.6A = 6 positions
- 2530.10.8A = 8 positions

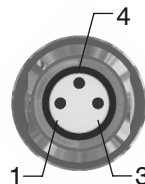
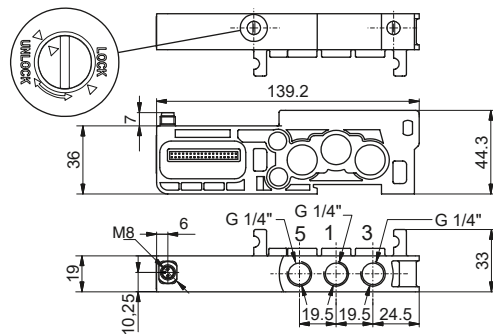
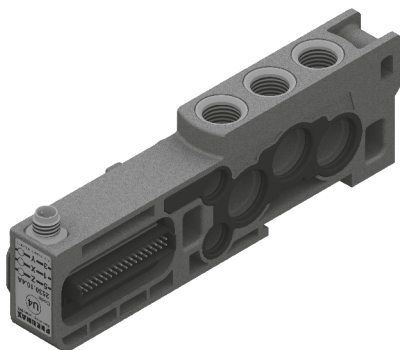

In particular this module is fitted with a M8 3 pins connector: +24V, not connected, GND.

PIN	DESCRIPTION
1	+24 VDC
4	NOT CONNECTED
3	GND

**WORKING PRINCIPLE / SIMPLIFIED FUNCTIONAL DIAGRAM**

This module uses an external power supply (+24VDC) to manage the solenoid valves.

The output signal from serial node / multi-pole connection is used as command signal: when it is high the +24VDC will be present at the module output.

If you want to cut off the power supply to a group of 2 valves it is sufficient to take away the +24VDC provided to the module by the M8 connector.

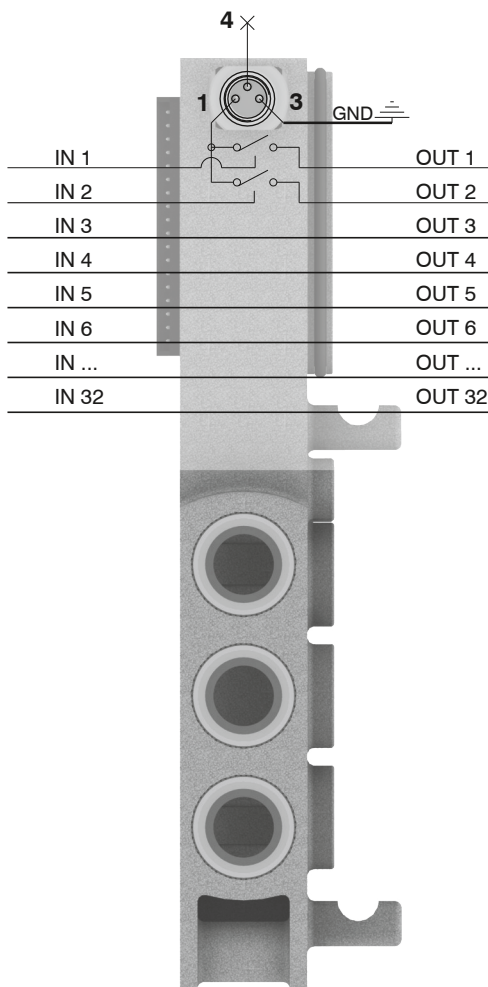

**Please note:** It is possible to use more modules to interrupt all the command signals, simply by inserting them before the signals to interrupt and after the signals already interrupted.

1 AIR DISTRIBUTION





**Usage examples:**

**EXAMPLE 1:**

Manifold of 12 monostable valves on which you want to interrupt signals 7-8

**Assembly:**

- 6 monostable valves (not interruptible because before the module),
- 1 additional power supply module,
- 6 monostable valves. Please note: the first 2 monostable of these are interruptible by the module, while the following 4 will work correctly managed directly by the corresponding command signals.

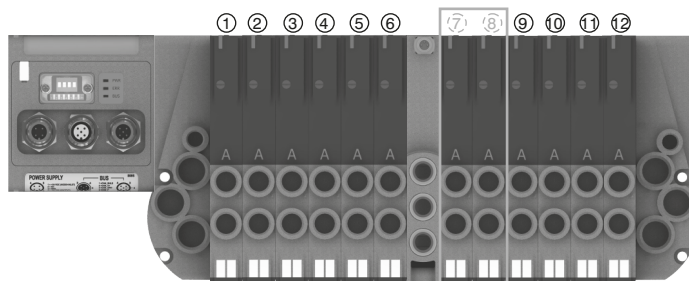

**EXAMPLE 2:**

Manifold of 12 monostable valves on which you want to interrupt signal 9

**Assembly:**

- 8 monostable valves (not interruptible because before the module),
- 1 additional power supply module,
- 1 monostable valve (interruptible),
- 1 closing plate mounted on a monostable base,
- 3 monostable valves (work correctly managed directly by the corresponding command signals).

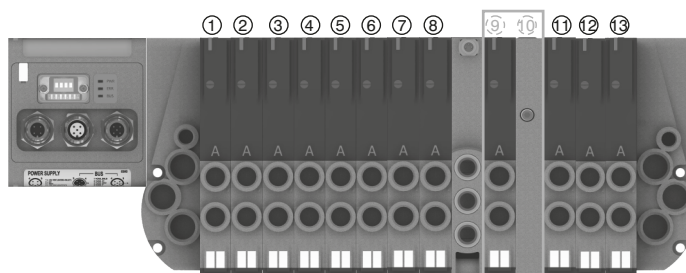

**Please note:** Each additional power supply module interrupts always 2 electrical signals.

- ☛ If you need to interrupt less than 2 signals you can:
  - assemble the valves to interrupt in the last positions of the manifold, so you don't need to worry about the interrupted exceeding signals;
  - use a bistable base and mount a monostable valve (for each signal less than the 2 standard);
  - use a monostable base and mount a closing plate (for each signal less than the 2 standard).

**EXAMPLE 3:**

Manifold of 7 monostable e 3 bistable valves on which you want to interrupt signals 2-3 and 8-9.

**Assembly:**

- 1 monostable valve (not interruptible because before the module),
- 1 additional power supply module,
- 6 monostable valves.

Please note: the first 2 monostable of these are interruptible by the module, while the following 4 will work correctly managed directly by the corresponding command signals.

- 1 additional power supply module,
- 3 bistable valves.

**Please note:** the first bistable of these valves is interruptible by the module, while the following 2 will work correctly managed directly by the corresponding command signals.

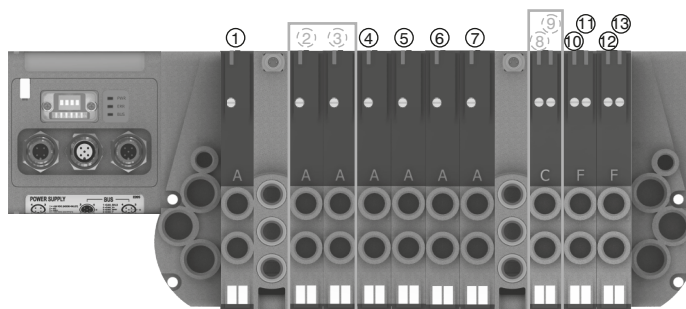

**General :**

Each Optyma-F manifold allows you to manage 32 command signals for the solenoid valves. Optyma-F serial nodes (CANopen®, DeviceNet, PROFIBUS DP, EtherCAT®, PROFINET IO RT, EtherNet/IP) have a single pin for the power supply of the solenoid valves.

So if you want to interrupt the power supply of one valve it is necessary to interrupt all the valves. The additional power supply module allows you to interrupt at the same time the first 2, 4, 6 or 8 available command signals for the valves after the module itself according to the selected device version. The additional power supply module is particularly useful also when you use control signals that block the valves. This application is effective both with serial management and multi-pole connection of the manifolds.

Furthermore, the electro-pneumatic cut off module allows you to interrupt the air flow that feeds the 12/14 pilots coming from upstream.

A threaded connection port incorporated in the module allows to pneumatically feed each pilots of a limited number of solenoid valves downstream.

This module has the same characteristics of an intermediate supply and exhaust module and fits directly into the Optyma-F series solenoid valve manifolds.

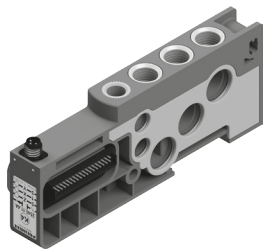

**Ordering code**

- 2530.11.2A = 2 positions
- 2530.11.4A = 4 positions
- 2530.11.6A = 6 positions
- 2530.11.8A = 8 positions

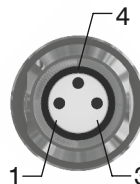
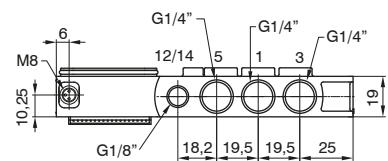
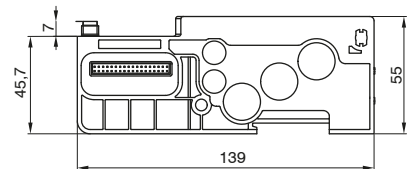

PIN	DESCRIPTION
1	+24 VDC
4	NOT CONNECTED
3	GND

In particular this module is fitted with a M8 3 pins connector: +24V, not connected, GND.

**WORKING PRINCIPLE / SIMPLIFIED FUNCTIONAL DIAGRAM**

This module uses an external power supply (+24VDC) to manage the solenoid valves.

The output signal from serial node / multi-pole connection is used as command signal: when it is high the +24VDC will be present at the module output.

If you want to cut off the power supply to a group of 4 valves it is sufficient to take away the +24VDC provided to the module by the M8 connector.

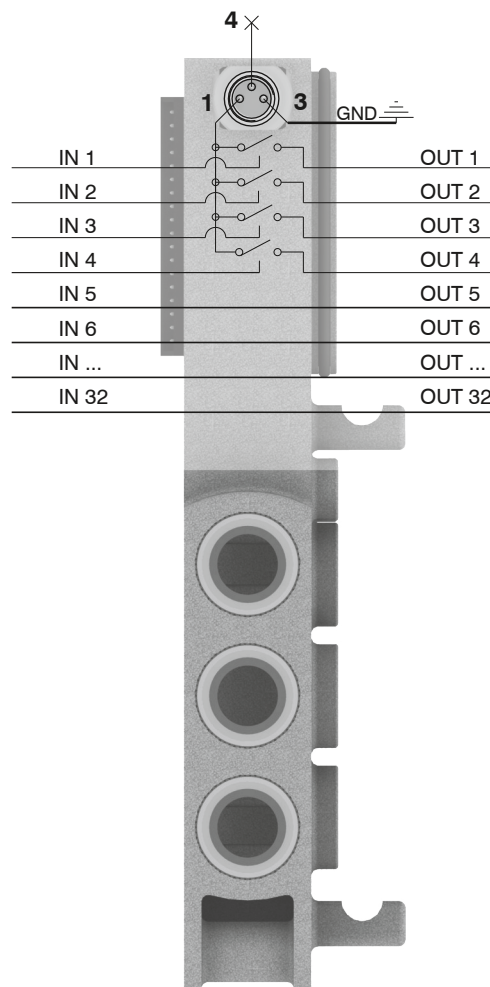

**Please note:** It is possible to use more modules to interrupt all the command signals, simply by inserting them before the signals to interrupt and after the signals already interrupted.

1 AIR DISTRIBUTION

**Usage examples:**

**EXAMPLE 1:**

Manifold of 12 monostable valves on which you want to interrupt signals 7-8-9-10

**Assembly:**

- 6 monostable valves (not interruptible because before the module),
- 1 additional power supply module,
- 6 monostable valves. Please note: the first 4 monostable of these are interruptible by the module, while the following 2 will work correctly managed directly by the corresponding command signals.

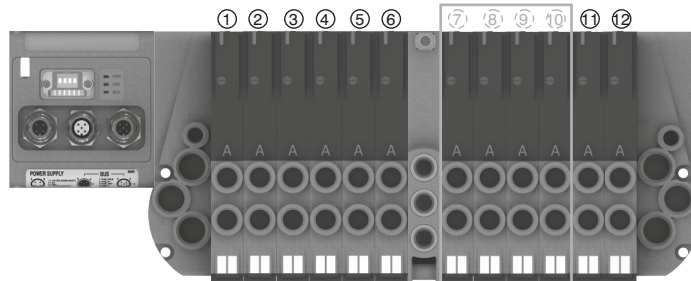

**EXAMPLE 2:**

Manifold of 12 monostable valves on which you want to interrupt signals 7-8-9

**Assembly:**

- 6 monostable valves (not interruptible because before the module),
- 1 additional power supply module,
- 3 monostable valves (interruptible),
- 1 closing plate mounted on a monostable base,
- 3 monostable valves (work correctly managed directly by the corresponding command signals).

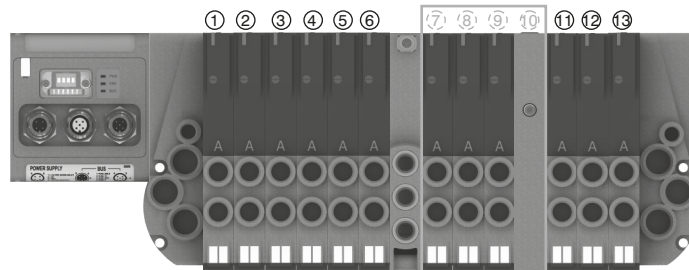

**Please note:** Each additional power supply module interrupts always 4 electrical signals.



If you need to interrupt less than 4 signals you can:

- assemble the valves to interrupt in the last positions of the manifold, so you don't need to worry about the interrupted exceeding signals;
- use a bistable base and mount a monostable valve (for each signal less than the 4 standard);
- use a monostable base and mount a closing plate (for each signal less than the 4 standard).

**EXAMPLE 3:**

Manifold of 7 monostable e 3 bistable valves on which you want to interrupt signals 2-3-4-5 and 8-9-10-11.

**Assembly:**

- 1 monostable valve (not interruptible because before the module),
- 1 additional power supply module,
- 6 monostable valves.

Please note: the first 4 monostable of these are interruptible by the module, while the following 2 will work correctly managed directly by the corresponding command signals.

- 1 additional power supply module,
- 3 bistable valves.

**Please note:** the first 2 bistable of these valves are interruptible by the module, while the following will work correctly managed directly by the corresponding command signals.

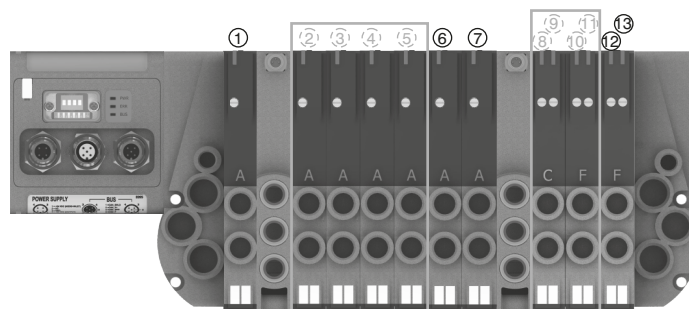



1  
AIR DISTRIBUTION

Polyethylene Silencer Series SPL-P

Coding: SPLP.**D**



TUBE DIAMETER	
<b>D</b>	18 = 1/8"
	14 = 1/4"
	38 = 3/8"

Diaphragm plug

Coding: 2530.17



Cable complete with connector, 25 Poles IP65

Coding: 2300.25.**L.C**



CABLE LENGTH	
<b>L</b>	03 = 3 meters
	05 = 5 meters
	10 = 10 meters
FUNCTION	
<b>F</b>	31 = Closed centres
	32 = Open centres
	33 = Pressured centres

Cable complete with connector, 37 Poles IP65

Coding: 2400.37.**L.C**



CABLE LENGTH	
<b>L</b>	03 = 3 meters
	05 = 5 meters
	10 = 10 meters
FUNCTION	
<b>F</b>	31 = Closed centres
	32 = Open centres
	33 = Pressured centres

Cable complete with connector, 25 Poles IP65

Coding: 2400.25.**L.25**



CABLE LENGTH	
<b>L</b>	03 = 3 meters
	05 = 5 meters
	10 = 10 meters



The electrical connection is achieved by a 37 pin connector and can manage up to 32 solenoid pilots.

It is also possible use a 25 sub-D pin connector and, in this case, it is possible to manage a maximum of 22 outputs. It is also available a terminal, able to manage a maximum of 16 outputs.

The management and distribution of the electrical signals between each valve is obtained thanks to an electrical connector which receives the signals from the previous module, uses one, two or none depending on the type, and carries forward to the next module the remaining.

Bistable valves, 5/3 and 2x3/2 valves which have two solenoid pilots built in, use two signals; the first is directed to the pilot side 14 the second to the pilot side 12. Modular bases can be fitted with two type of electrical connector: the monostable version uses only one signal (connected to the pilot side 14) and carries forward the remaining, the bistable version which always uses two signals.

This solution allows the modification of the manifold (replacement of monostable valves without bistable for example) without having to reset the PLC output layout.

On other hand this solution limits the maximum number of valves to 16 when it is used a 37 pin connector or 11 when it is used a 25 pin connector. When using a Endplates with terminal, the maximum number of valves are 8.

Intermediate supply/exhaust module uses an electrical connector directly forwarding signals to the next one without any kind of modification.

This allows the use of intermediate modules in any position of the manifold.

All the electrical signals that have not been used on the manifold can be used placing at the end of the manifold the end plate complete with the 25 sub-D female connector.

The number of available signals depends of the connector used to the type of the left end plate and by the total signals used along the manifold:

37 pin connector	nr of output = 32 – (total of used signals)
25 pin connector	nr of output = 22 – (total of used signals)
Terminal	nr of output = 16 – (total of used signals)

Following we show some examples of possible combination and the relative pin assignment.

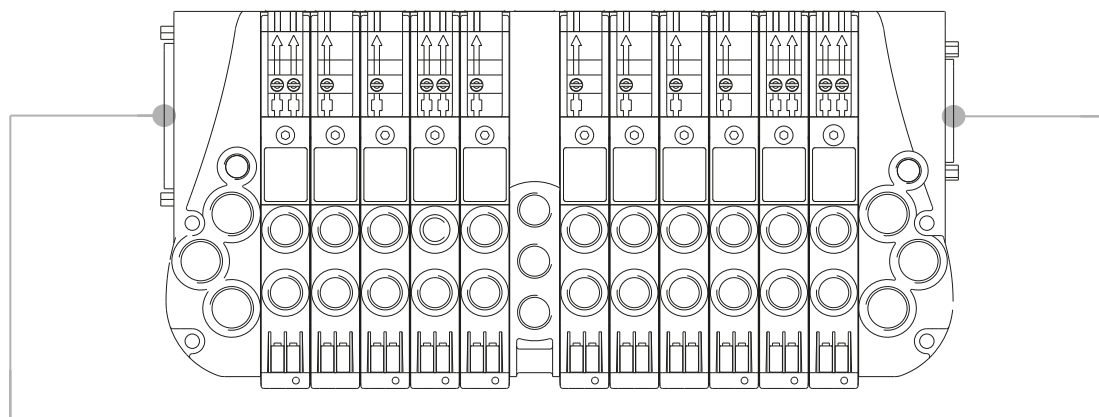

**IN-LET ELECTRIC CONNECTIONS**

**SUB-D 37 POLE MALE CONNECTOR**

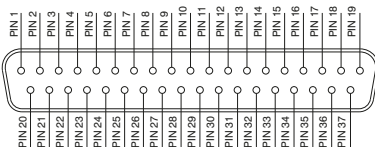

1 - 32 = Solenoid valves signals  
33 - 35 = GND  
36 - 37 = Through line

**SUB-D 25 POLE MALE CONNECTOR**

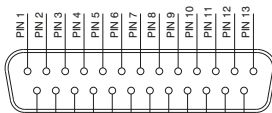

1 - 22 = Solenoid valves signals  
23 - 24 = GND  
25 = Through line

**TERMINAL 16 SIGNALS**

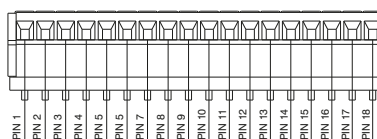

POS. 1-16 = SIGNALS  
POS. 17 = GND  
POS. 18 = THROUGH LINE

**OUTLET ELECTRIC CONNECTIONS (IF PRESENT)**

**SUB-D 25 POLE FEMALE CONNECTOR**

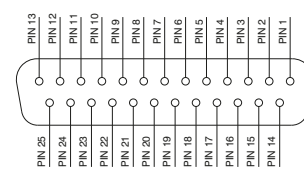

1 - 22 = Solenoid valves signals  
23 - 24 = GND  
25 = Through line

37 PIN Connector correspondence for valves assembled on mixed bases

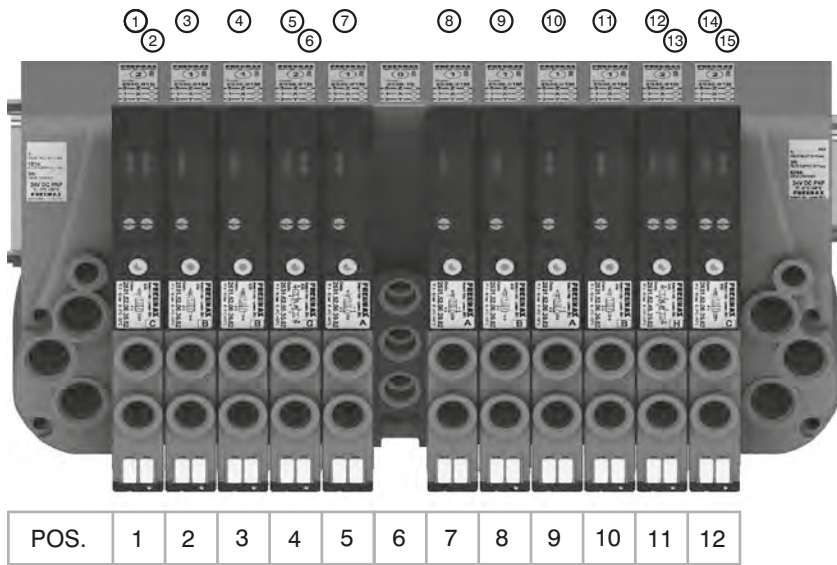

- PIN 1 = PILOT 14 SV POS.1
- PIN 2 = PILOT 12 SV POS.1
- PIN 3 = PILOT 14 SV POS.2
- PIN 4 = PILOT 14 SV POS.3
- PIN 5 = PILOT 14 SV POS.4
- PIN 6 = PILOT 12 SV POS.4
- PIN 7 = PILOT 14 SV POS.5
- PIN 8 = PILOT 14 SV POS.7
- PIN 9 = PILOT 14 SV POS.8
- PIN 10 = PILOT 14 SV POS.9
- PIN 11 = PILOT 14 SV POS.10
- PIN 12 = PILOT 14 SV POS.11
- PIN 13 = PILOT 12 SV POS.11
- PIN 14 = PILOT 14 SV POS.12
- PIN 15 = PILOT 12 SV POS.12

37 PIN Connector correspondence for manifold mounted on bases for bistable valves

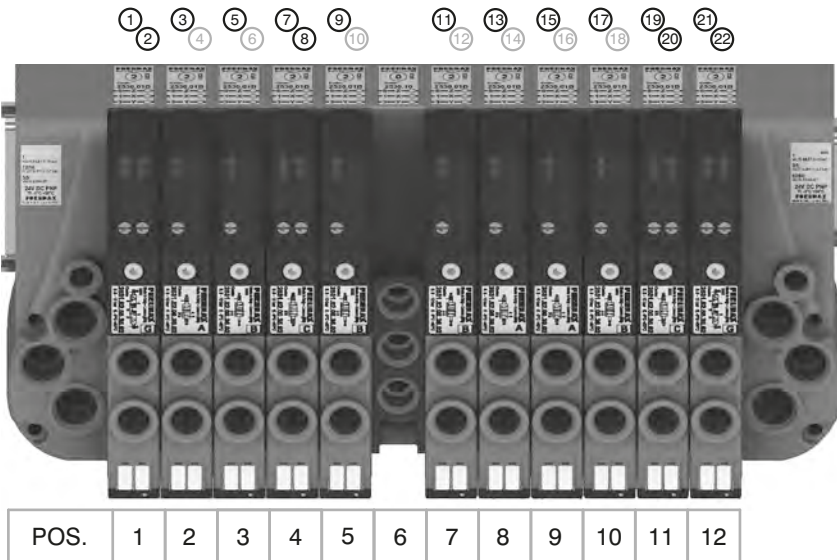

- PIN 1 = PILOT 14 SV POS.1
- PIN 2 = PILOT 12 SV POS.1
- PIN 3 = PILOT 14 SV POS.2
- PIN 4 = NOT CONNECTED
- PIN 5 = PILOT 14 SV POS.3
- PIN 6 = NOT CONNECTED
- PIN 7 = PILOT 14 SV POS.4
- PIN 8 = PILOT 12 SV POS.4
- PIN 9 = PILOT 14 SV POS.5
- PIN 10 = NOT CONNECTED
- PIN 11 = PILOT 14 SV POS.7
- PIN 12 = NOT CONNECTED
- PIN 13 = PILOT 14 SV POS.8
- PIN 14 = NOT CONNECTED
- PIN 15 = PILOT 14 SV POS.9
- PIN 16 = NOT CONNECTED
- PIN 17 = PILOT 14 SV POS.10
- PIN 18 = NOT CONNECTED
- PIN 19 = PILOT 14 SV POS.11
- PIN 20 = PILOT 12 SV POS.11
- PIN 21 = PILOT 14 SV POS.12
- PIN 22 = PILOT 12 SV POS.12

37 PIN Connector correspondence for manifold for 32 position manifold with monostable valves on base

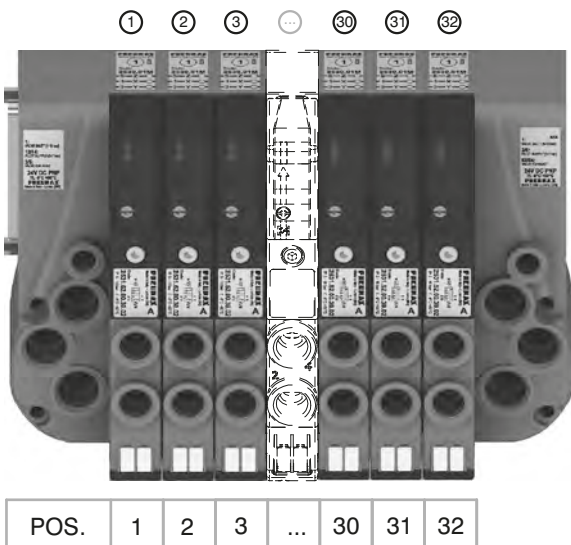

25 PIN Connector correspondence for manifold for 22 position manifold with monostable valves on base

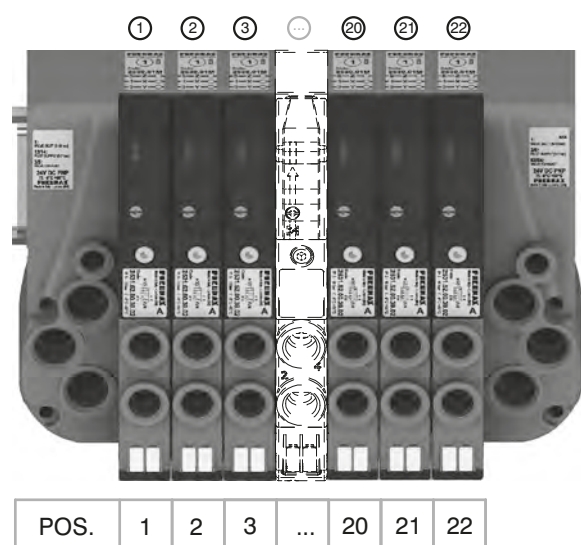

AIR DISTRIBUTION

1



**General :**

Using the 2530.03.25P output terminal it is possible to make any electrical signals not used by valves available on a 25 sub-D female connector at the right end of the manifold.  
It is possible to then join a multi-core cable to link to the next manifold, or connect directly to one or two I/O modules.  
The I/O modules can accept input or output signals, depending upon what is connected.

**Please note:** If the manifold is connected by a multi-core connection, each connection can be used as either an input or an output, while if the manifold is connected to a serial node the connections can only be used as an output.

It is possible to connect the manifold to up to two I/O modules.

Each I/O module includes 8 diagnostic LEDs which indicate the presence of an Input / Output signal for each connector.

**Please note:** For an LED to function, a signal of at least +15VDC must be present on pin 4 of the connector. If this signal is lower, the LED will not light, this does not compromise the normal Input / Output function of the unit.

**Ordering code**

**2530.08F**

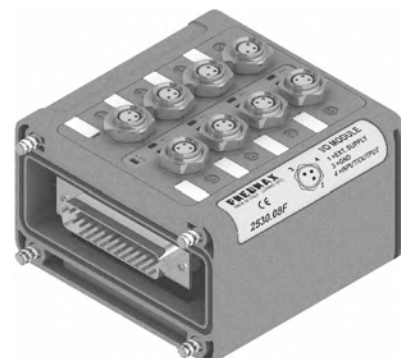

1  
AIR DISTRIBUTION

**Overall dimensions and I/O layout :**

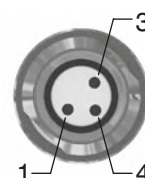
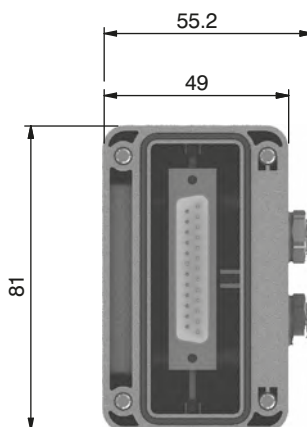
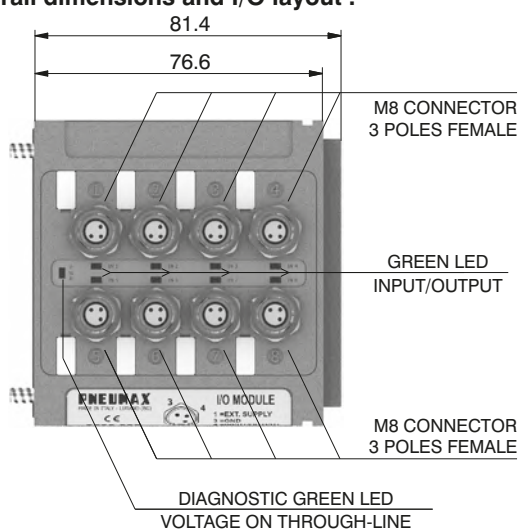

PIN	DESCRIPTION
1	+24 VDC
4	INPUT/OUTPUT
3	GND

**Input features:**

Each connection can accept either two wire (switches, magnetic switches, pressure switches, etc.) or three wire connections (photocells, electronic end of stroke sensors, etc.) If +24VDC is required on at Pin 1 of each connector, it is possible to provide this via the through-line pin of the multi-pole connector.

I.E :

Pin 25 of the 25 pin multi-pole connector (code 2530.02.25P or 2530.12.25P)

Pin 36-37 of the 37 pin multi-pole connector (code 2530.02.37P or 2530.12.37P)

**Output features:**



**Attention:** The output connections are not protected against short-circuit. Please pay attention when wiring (avoid Pin 4 being connected to Pin 3 or Pin 1).

<b>General characteristics</b>	Model	2530.08F
	Case	Reinforced technopolymer
	I/O Connector	M8 connector 3 poles female (IEC 60947-5-2)
	PIN1 voltage (connector used as Input)	By the user
	PIN 4 voltage diagnosis	Green LED
	Node consumption (Outlets excluded)	7mA per each LED with 24 VDC signal
	Outlets voltage	+23,3 VDC (serial) /by the user (multipolar)
	Input voltage	Depend by the using
	Maximum outlet current	100 mA (serial) / 400 mA (multipolar)
	Maximum Input/Output	8 per module
	Multiconnector max. Current	100 mA
	Connections to manifold	Direct connection to 25 poles connector
	Maximum n. of moduls	2
	Protection degree	IP65 when assembled
Ambient temperature	from -0° to +50° C	

**CORRESPONDENCE BETWEEN MULTI-POLE SIGNAL AND CONNECTOR**

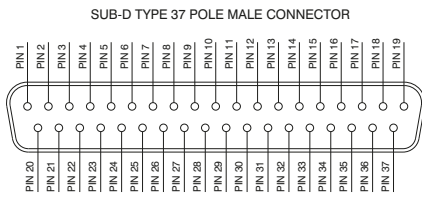

1 - 32 = SIGNALS  
 33 - 35 = GND  
 36 - 37 = THROUGH LINE

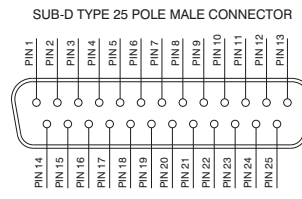

1 - 22 = SIGNALS  
 23 - 24 = GND  
 25 = THROUGH LINE

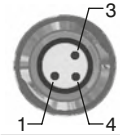

PIN DESCRIPTION	
1	THROUGH LINE
4	SIGNAL
3	GND

**Connection modes:**

The I/O module changes its operation depending on the way the manifold is controlled. There are two possible modes:

- A) Control via multi-pole connection
- B) Control via fieldbus

**A) Control via multi-pole :**

*M8 connector used as Input:*



**Attention:** Voltage applied to each connector is passed to multi-pole connector pin.

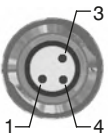

PIN DESCRIPTION	
1	THROUGH LINE
4	SIGNAL
3	GND

In order to use the I/O module, the correct right hand endplate with 25 pole female outlet connector must be used. (Code 2530.03.25P).



*M8 connector used as Output:*

Output voltage will be the same as is applied at the multi-pole connector pin. The maximum output current depends upon the power unit used, but we recommend no more than 250mA.



**Attention:** Since every cable has a degree of resistance, there will always be a voltage drop depending on the cable's length, sectional area and the current.

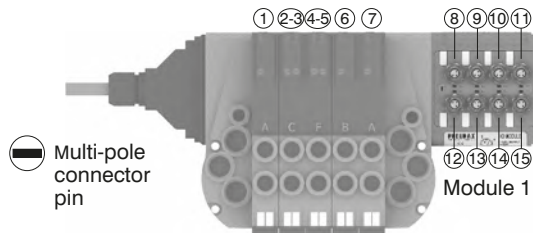

**Attention:** Only one more I/O module can be added.

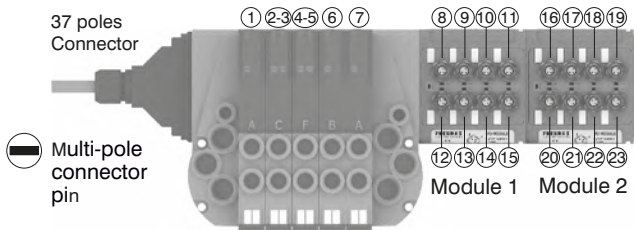

**Attention:** No more additions are possible

**Attention :** Optyma 32-F solenoid valve manifolds permit up to 22 electrical signals that are not used by manifolds to be made available: these signals can be managed by another manifold and / or by I/O modules. The I/O module will manage these unused signals. Connections that are not managing useful signals will remain unconnected.

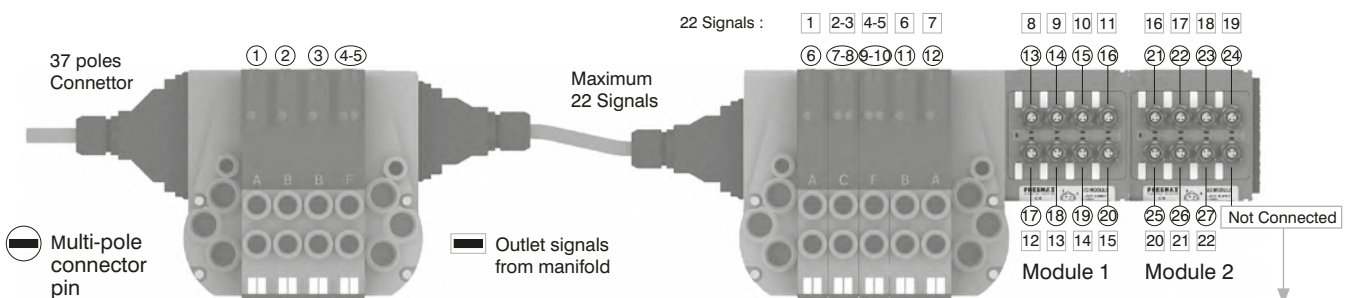

**Attention:** Signal Not connected  
 GND Connected  
 Through line Connected

**Please note:** this example considers a 37 pin multi-pole connector. The same configuration managed by a 25 pin multi-pole connector will stop at number 22 of multi-pole connector and at number 17 of the manifold. 22 17

AIR DISTRIBUTION 1





**Please note:** Optyima 32-F solenoid valve manifolds manage up to 32 signals. If the manifold uses more than 24 signals the I/O module will manage only the remainder. Connections that are not managing useful signals will remain unconnected.

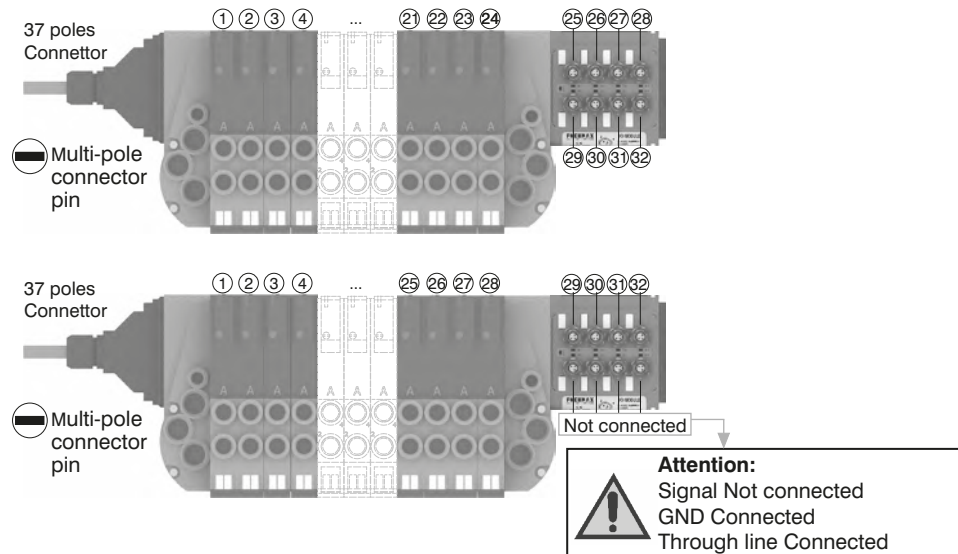

**B) Control via fieldbus:**

With this kind of control the I/O module can only be used as an output. Pin 1 of each connector is not connected. The output voltage will be 0.7V lower than that applied to Pin 4 of the connector. The maximum output current for each output is 100mA. The correspondence between control byte and each single output depends on how many electrical signals are used by the manifold and by the relative position of the I/O module.

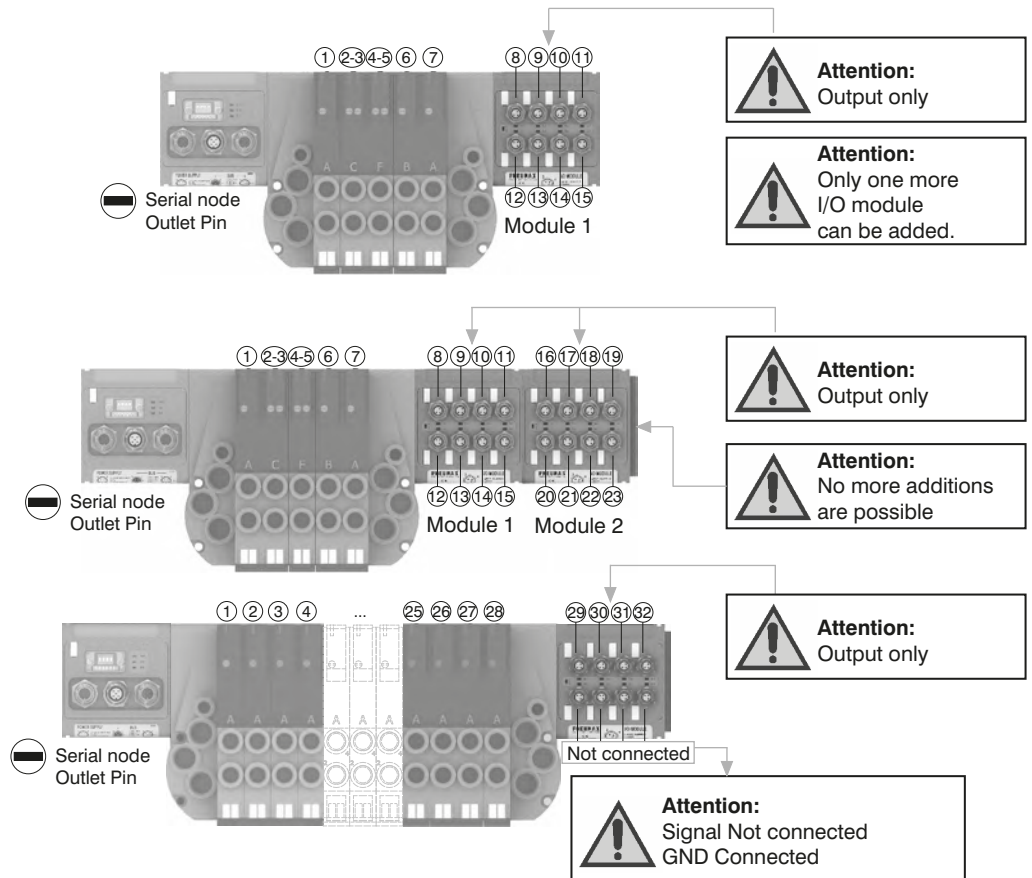
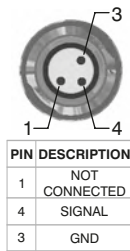

**Please note:** I/O modules don't allow to connect any additional valves manifold after them.

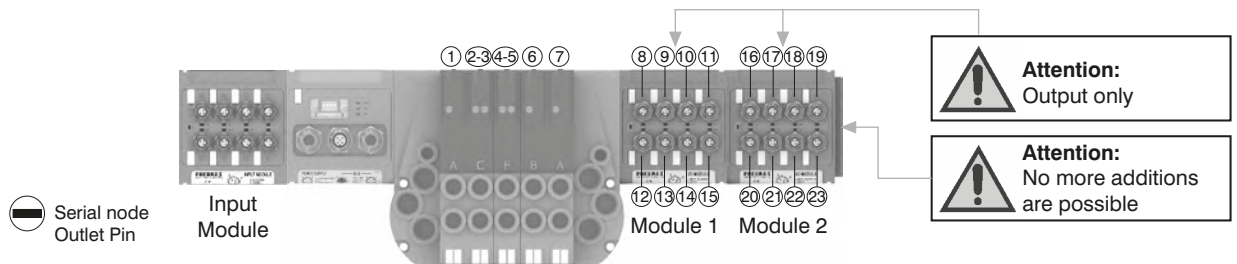

1  
AIR DISTRIBUTION

From the top

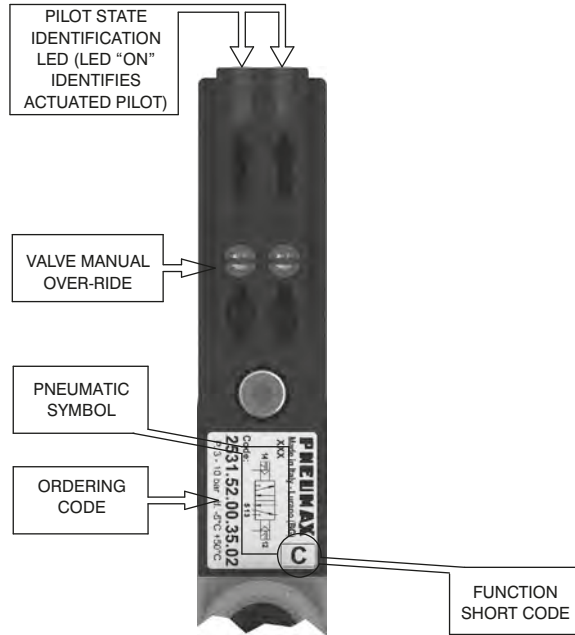
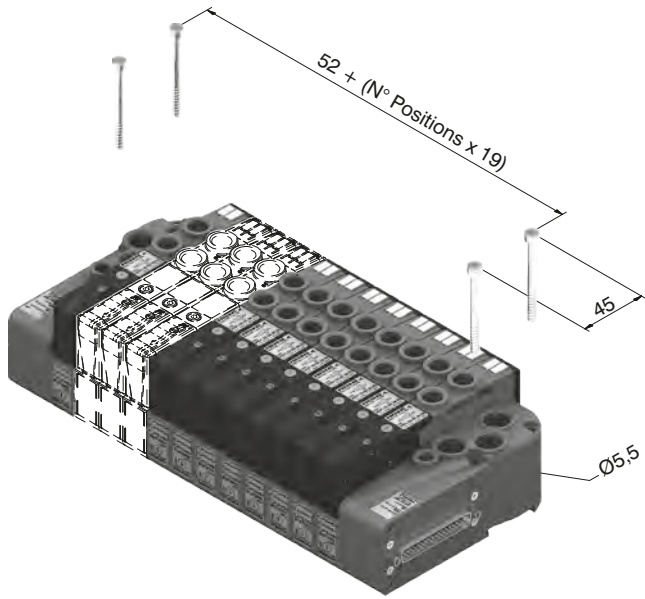

DIN rail fixing

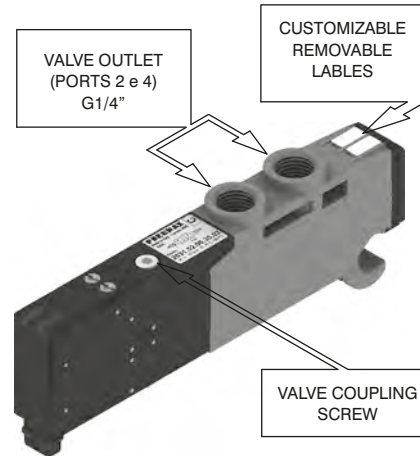
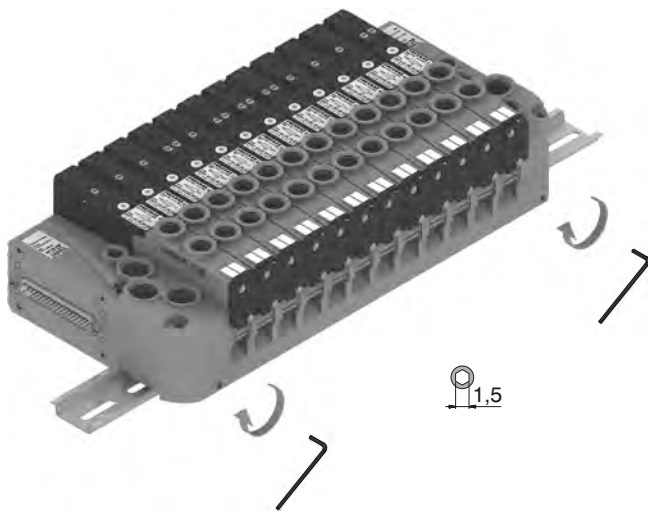

Maximum possible size according to valves seats

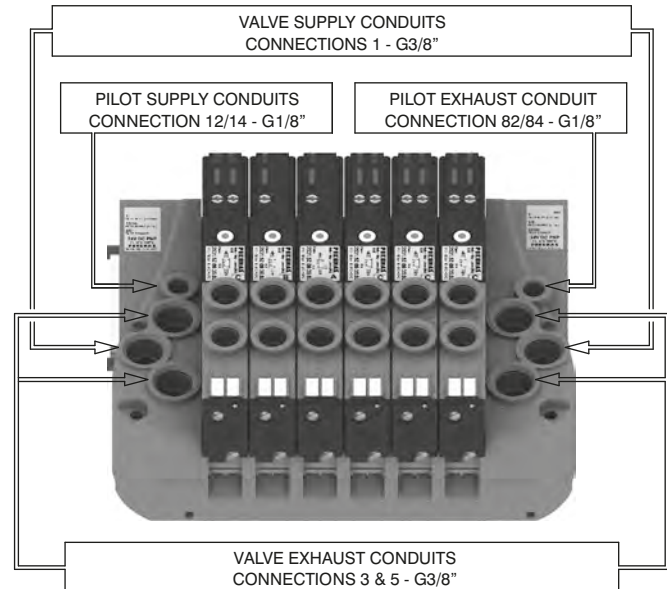
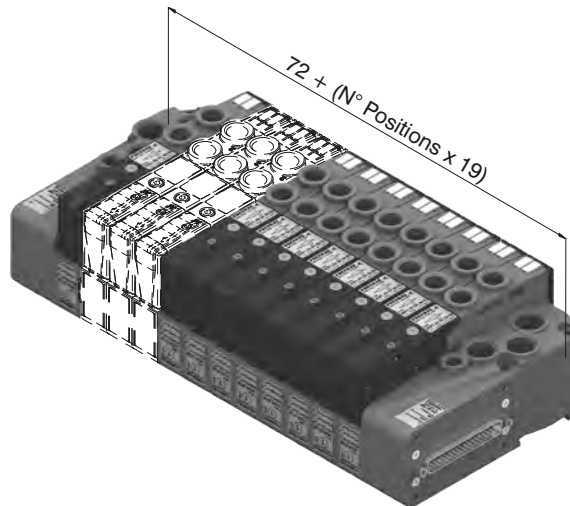

Manual override actuation

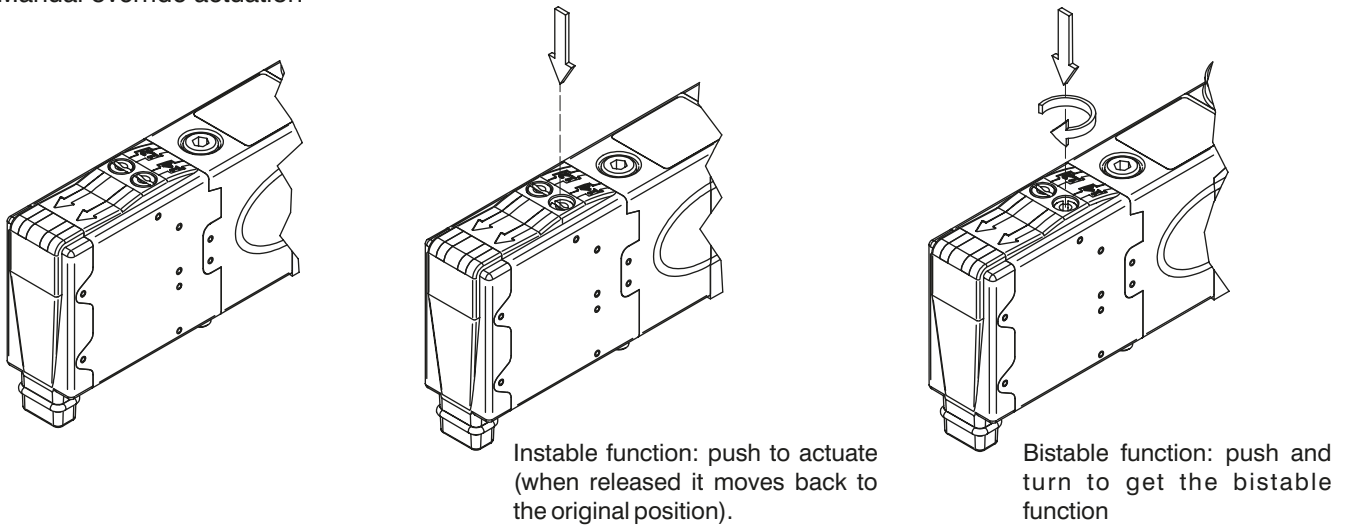

NOTE : It is strongly suggested to replace the original position after using

Valve Installation

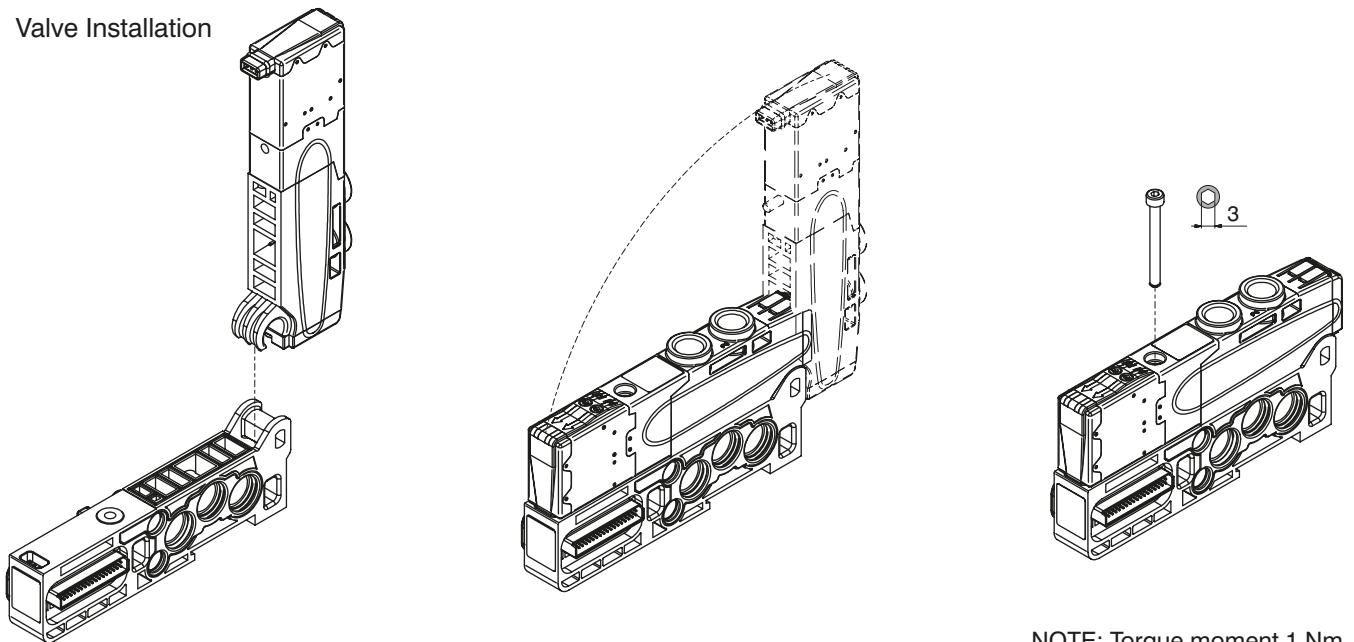

NOTE: Torque moment 1 Nm

Manifold assembly

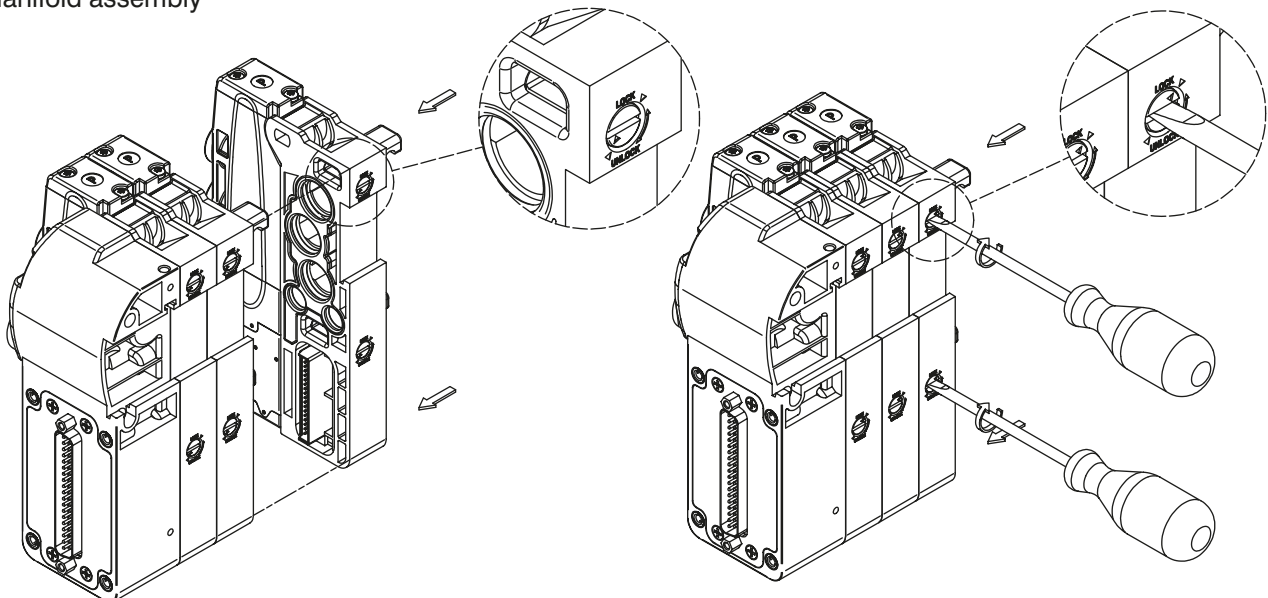

Manifold Layout configuration

1 AIR DISTRIBUTION

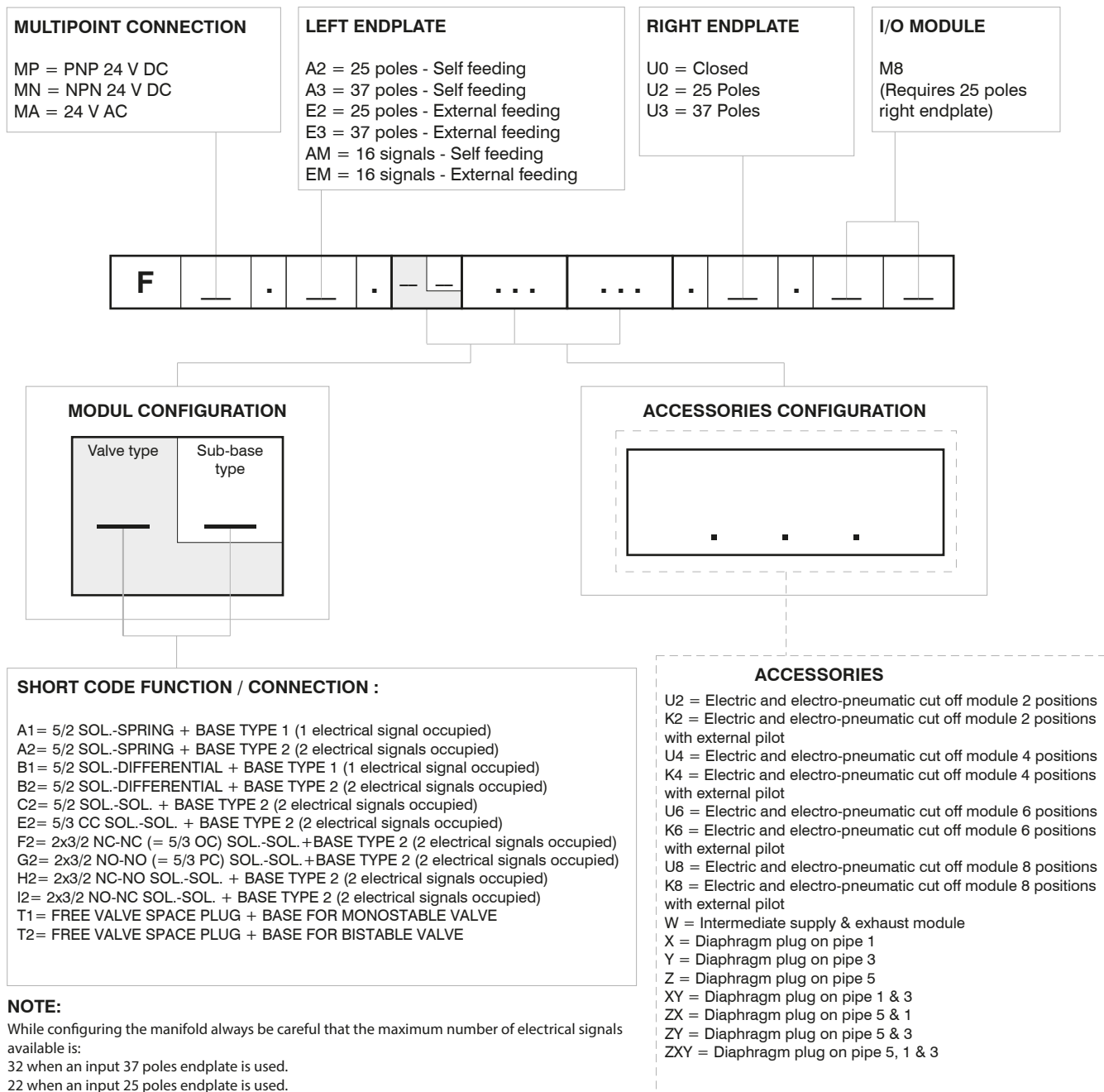

**NOTE:**  
 While configuring the manifold always be careful that the maximum number of electrical signals available is:  
 32 when an input 37 poles endplate is used.  
 22 when an input 25 poles endplate is used.  
 The use of monostable valve mounted on a base type 2 ( 2 electrical signals occupied ) causes the loss of one electric signal.  
 In this case the monostable valve can be replaced by a bistable valve. The diaphragms plugs are used to intercept the conduits 1,3 & 5 of the base. If it is necessary to interrupt more than one conduit in the same time then put in line the letters which identifies the position (for example : regarding the 3 & 5 conduits, put the Y & Z letters).  
 Should one or more conduits be cut more than one time it is necessary to add the relevant intermediate Supply/Exhaust module.

**Series 2500 OPTYMA-F solenoid valve manifolds managed by multipoint connection are "well tried components"**

	<b>Well-ried component</b>	- The product is a well-tried product for a safety-related application according to ISO 13849-1. - The relevant basic and well-tried safety principles according ISO 13849-2 for this product are fulfilled.
<b>B<sub>10d</sub></b>	50.000.000	- The suitability of the product for a precise application must be verified and confirmed by the user.



**General:**

CANopen® module is directly integrated on Optyima-F solenoid valves manifold via a 37 poles connector, normally used for multipolar cable connection.  
Optyima-F solenoid valves connected to node must be PNP equivalent (final 02 in ordering code).

The node can be easily installed also on solenoid valves manifold already mounted on equipment.

Module can manage up to 32 solenoid valves, and, in the same time, a max number of 4 Input modules 5225.08F or a max number of 2 Input modules 5225.25F.

CANopen® module recognizes automatically the presence of the Input modules on power on.

Regardless of the number of Input modules connected, the managable solenoid valves are 32.

Node power supply is made by a M12 4P male circular connector.

The separation between node 24 VDC Power supply and outputs 24 VDC allows to switch off the outputs maintaining powered the node and inputs, if present.

Connection to Bus CANopen® is possible via 2 M12 5P male - female circular connectors; these two are connected in parallel and according to CiA Draft Recommendation 303-1 (V. 1.3 : 30 December 2004).

Transmission speed can be set by 3 dip-switches.

The node address can be set by 6 dip-switches using BCD numeration.

The module includes an internal terminating resistance that can be activated by a dip-switch.

**Ordering code**

**5525.32F**



1  
AIR DISTRIBUTION

**Scheme / Overall dimensions and I/O layout :**

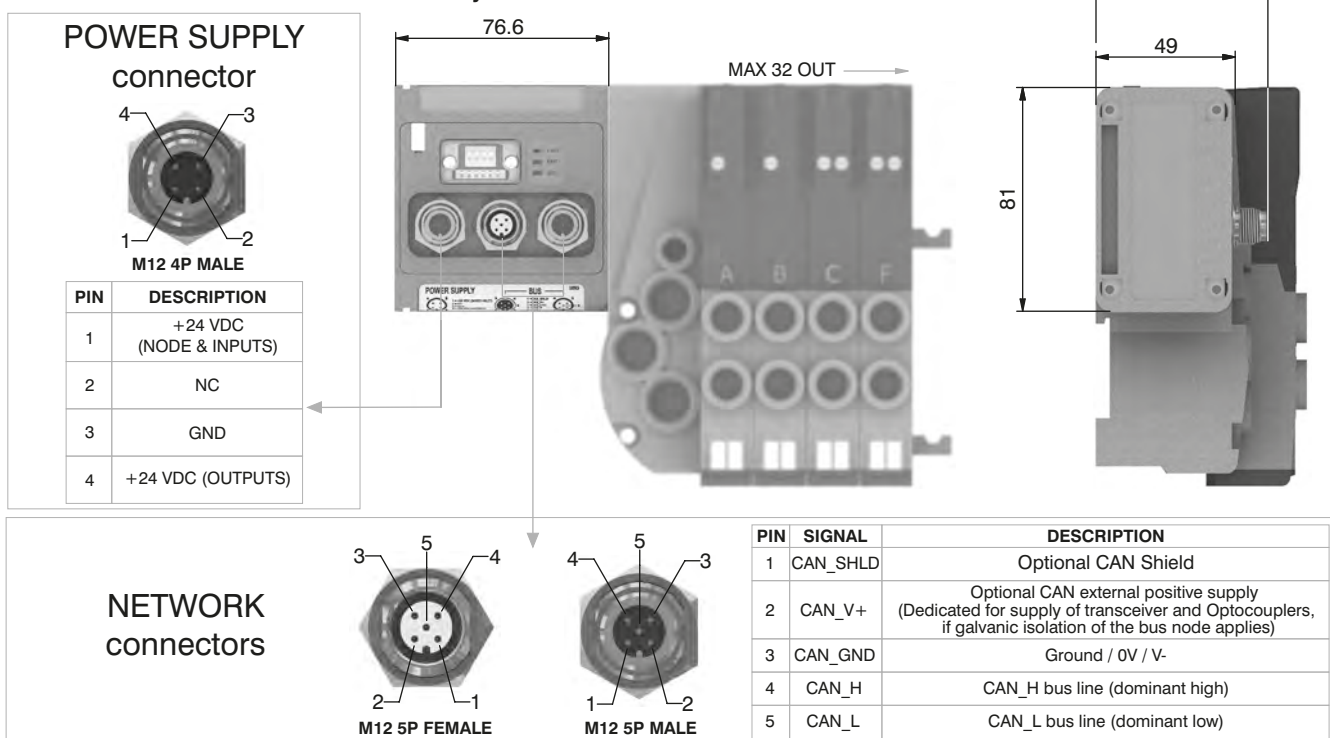

**Technical characteristics**

	Model	5525.32F
	Specifications	CiA Draft Standard Proposal 301 V 4.10 (15 August 2006)
	Case	Reinforced technopolymer
<b>Power supply</b>	Power supply connection	M12 4P male connector (IEC 60947-5-2)
	Power supply voltage	+24 VDC +/- 10%
	Node consumption (without inputs)	30 mA
	Power supply diagnosis	Green LED PWR
<b>Outputs</b>	PNP equivalent outputs	+24 VDC +/- 10%
	Maximum current for output	100 mA
	Maximum output number	32
	Max output simultaneously actuated	32
<b>Network</b>	Network connectors	2 M12 5P connectors male-female type A (IEC 60947-5-2)
	Baud rate	10 - 20 - 50 - 125 - 250 - 500 - 800 - 1000 Kbit/s
	Addresses, possible numbers	From 1 to 63
	Max nodes in net	64 (slave + master)
	Bus maximum recommended length	100 m at 500 Kbit/s
	Bus diagnosis	Green LED + Red LED
	Configuration file	Available from our web site: <a href="http://www.pneumaxspa.com">http://www.pneumaxspa.com</a>
	IP protection grade	IP65 when assembled
	Temperature range	From 0° to +50° C

**General:**

DeviceNet module is directly integrated on Optyima-F solenoid valves manifold via a 37 poles connector, normally used for multipolar cable connection.  
 Optyima-F solenoid valves connected to node must be PNP equivalent (final 02 in ordering code).

The node can be easily installed also on solenoid valves manifold already mounted on equipment.

Module can manage up to 32 solenoid valves, and, in the same time, a max number of 4 Input modules 5225.08F or a max number of 2 Input modules 5225.25F.

DeviceNet module recognizes automatically the presence of the Input modules on power on.

Regardless of the number of Input modules connected, the managable solenoid valves are 32.

Node power supply is made by a M12 4P male circular connector.

The separation between node 24 VDC Power supply and outputs 24 VDC allows to switch off the outputs maintaining powered the node and inputs, if present.

Connection to Bus DeviceNet is possible via 2 M12 5P male - female circular connectors; these two are connected in parallel and according to DeviceNet Specifications Volume I, release 2.0.

Transmission speed can be set by 3 dip-switches.

The node address can be set by 6 dip-switches using BCD numeration.

The module includes an internal terminating resistance that can be activated by a dip-switch.

**Ordering code**

**5425.32F**



AIR DISTRIBUTION

**Scheme / Overall dimensions and I/O layout :**

**POWER SUPPLY connector**

**M12 4P MALE**

PIN	DESCRIPTION
1	+24 VDC (NODE & INPUTS)
2	NC
3	GND
4	+24 VDC (OUTPUTS)

**NETWORK connectors**

**M12 5P FEMALE**

**M12 5P MALE**

PIN	SIGNAL	DESCRIPTION
1	CAN_SHLD	Optional CAN Shield
2	CAN_V+	Optional CAN external positive supply (Dedicated for supply of transceiver and Optocouplers, if galvanic isolation of the bus node applies)
3	CAN_GND	Ground / 0V / V-
4	CAN_H	CAN_H bus line (dominant high)
5	CAN_L	CAN_L bus line (dominant low)

**Technical characteristics**

	Model	5425.32F
	Specifications	DeviceNet Specifications Volume I, release 2.0.
	Case	Reinforced technopolymer
<b>Power supply</b>	Power supply connection	M12 4P male connector (IEC 60947-5-2)
	Power supply voltage	+24 VDC +/- 10%
	Node consumption (without inputs)	30 mA
	Power supply diagnosis	Green LED PWR
<b>Outputs</b>	PNP equivalent outputs	+24 VDC +/- 10%
	Maximum current for output	100 mA
	Maximum output number	32
	Max output simultaneously actuated	32
<b>Network</b>	Network connectors	2 M12 5P connectors male-female type A (IEC 60947-5-2)
	Baud rate	125 - 250 - 500 Kbit/s
	Addresses, possible numbers	From 1 to 63
	Max nodes in net	64 (slave + master)
	Bus maximum recommended length	100 m at 500 Kbit/s
	Bus diagnosis	Green LED + Red LED
	Configuration file	Available from our web site: <a href="http://www.pneumaxspa.com">http://www.pneumaxspa.com</a>
	IP protection grade	IP65 when assembled
	Temperature range	From 0° to +50° C



**General:**

PROFIBUS DP module is directly integrated on Optyima-F solenoid valves manifold via a 37 poles connector, normally used for multipolar cable connection.

Optyima-F solenoid valves connected to node must be PNP equivalent (final 02 in ordering code). The node can be easily installed also on solenoid valves manifold already mounted on equipment.

Module can manage up to 32 solenoid valves, and, in the same time, a max number of 4 Input modules 5225.08F or a max number of 4 Input modules 5225.25F.

PROFIBUS DP module recognizes automatically the presence of the Input modules on power on. Regardless of the number of Input modules connected, the manageable solenoid valves are 32.

Node power supply is made by a M12 4P male circular connector.

The separation between node 24 VDC Power supply and outputs 24 VDC allows to switch off the outputs maintaining powered the node and inputs, if present.

Connection to Bus PROFIBUS DP is possible via 2 M12 type B 5P male - female circular connectors; these two are connected in parallel and according to PROFIBUS Interconnection Technology (Version 1.1 : August 2001).

The node address can be set using BCD numeration: 4 dip-switches for the units and 4 dip-switches for the tens.

The module includes an internal terminating resistance that can be activated by 2 dip-switches.

**Ordering code**

**5325.32F**



1  
AIR DISTRIBUTION

**Scheme / Overall dimensions and I/O layout :**

**POWER SUPPLY connector**

**M12 4P MALE**

PIN	DESCRIPTION
1	+24 VDC (NODE & INPUTS)
2	NC
3	GND
4	+24 VDC (OUTPUTS)

**NETWORK connectors**

**M12 5P FEMALE**

**M12 5P MALE**

PIN	SIGNAL	DESCRIPTION
1	VP	Power supply plus, (P5V)
2	A-line	Receive / Transmit data -N, A-line
3	DGND	Data Ground (reference potential to VP)
4	B-line	Receive / Transmit data -plus, B-line
5	SHIELD	Shield or PE

**Technical characteristics**

	Model	5325.32F
	Specifications	PROFIBUS DP
	Case	Reinforced technopolymer
<b>Power supply</b>	Power supply connection	M12 4P male connector (IEC 60947-5-2)
	Power supply voltage	+24 VDC +/- 10%
	Node consumption (without inputs)	50 mA
	Power supply diagnosis	Green LED PWR / Green LED OUT
<b>Outputs</b>	PNP equivalent outputs	+24 VDC +/- 10%
	Maximum current for output	100 mA
	Maximum output number	32
	Max output simultaneously actuated	32
<b>Network</b>	Network connectors	2 M12 5P male-female connectors type B
	Baud rate	9,6 - 19,2 - 93,75 - 187,5 - 500 - 1500 - 3000 - 6000 - 12000 Kbit/s
	Addresses, possible numbers	From 1 to 99
	Max nodes in net	100 (slave + master)
	Bus maximum recommended length	100 m at 12 Mbit/s - 1200 m at 9,6 Kbit/s
	Bus diagnosis	Green LED + Red LED
	Configuration file	Available from our web site: <a href="http://www.pneumaxspa.com">http://www.pneumaxspa.com</a>
	IP protection grade	IP65 when assembled
	Temperature range	From 0° to +50° C

**General:**

EtherCAT® module is directly integrated on Optyma-F solenoid valves manifold via a 37 poles connector, normally used for multipolar cable connection.

Optyma-F solenoid valves connected to node must be PNP equivalent (final 02 in ordering code). The node can be easily installed also on solenoid valves manifold already mounted on equipment.

Module can manage up to 32 solenoid valves, and, in the same time, a max number of 4 Input modules 5225.08F or a max number of 2 Input modules 5225.25F.

The EtherCAT® module, regardless the number of Input module connected, reports to have connected 4 Input modules.

Regardless of the number of Input modules connected, the manageable solenoid valves are 32.

Node power supply is made by a M12 4P male circular connector.

The separation between node 24 VDC Power supply and outputs 24 VDC allows to switch off the outputs maintaining powered the node and inputs, if present.

Connection to Bus EtherCAT® is possible via 2 M12 4P type D female circular connectors. These two connectors lead the signal to two different communication ports, so they are not connected in parallel.

The node address is assigned during configuration.

**Note: 5700 series has a different configuration file from series 5600.**

**Ordering code**

**5725.32F.EC**



**Scheme / Overall dimensions and I/O layout :**

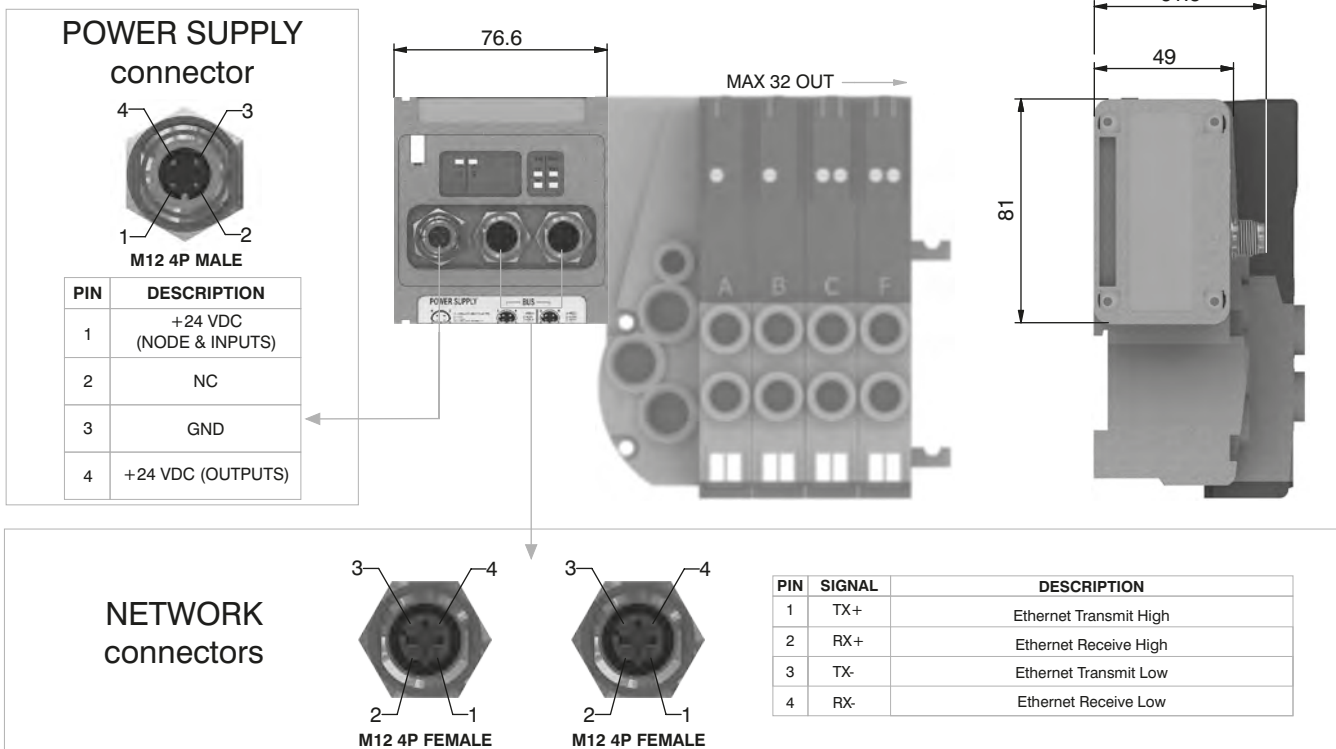

**Technical characteristics**

	Model	5725.32F.EC
	Specifications	EtherCAT® Specifications ETG.1000 series
	Case	Reinforced technopolymer
<b>Power supply</b>	Power supply connection	M12 4P male connector (IEC 60947-5-2)
	Power supply voltage	+24 VDC +/- 10%
	Node consumption (without inputs)	400 mA
	Power supply diagnosis	Green LED PWR / Green LED OUT
<b>Outputs</b>	PNP equivalent outputs	+24 VDC +/- 10%
	Maximum current for output	100 mA
	Maximum output number	32
	Max output simultaneously actuated	32
<b>Network</b>	Network connectors	2 M12 4P female connectors type D (IEC 61076-2-101)
	Baud rate	100 Mbit/s
	Addresses, possible numbers	From 1 to 65535
	Max nodes in net	65536 (slave + master)
	Maximum distance between 2 nodes	100 m
	Bus diagnosis	1 green and 1 red LED for status + 2 LEDs for link & activity
	Configuration file	Available from our web site: <a href="http://www.pneumaxspa.com">http://www.pneumaxspa.com</a>
	IP protection grade	IP65 when assembled
	Temperature range	From 0° to +50° C





**General:**

PROFINET IO RT module is directly integrated on Optyima-F solenoid valves manifold via a 37 poles connector, normally used for multipolar cable connection.  
Optyima-F solenoid valves connected to node must be PNP equivalent (final 02 in ordering code).

The node can be easily installed also on solenoid valves manifold already mounted on equipment.

Module can manage up to 32 solenoid valves, and, in the same time, a max number of 4 Input modules 5225.08F or a max number of 4 Input modules 5225.25F.

The PROFINET IO RT module, regardless the number of Input module connected, reports to have connected 8 Input modules.

Regardless of the number of Input modules connected, the manageable solenoid valves are 32.

Node power supply is made by a M12 4P male circular connector.

The separation between node 24 VDC Power supply and outputs 24 VDC allows to switch off the outputs maintaining powered the node and inputs, if present.

Connection to Bus PROFINET IO RT is possible via 2 M12 4P type D female circular connectors. These two connectors lead the signal to two different communication ports, so they are not connected in parallel.

The node address is assigned during configuration.

**Ordering code**

**5725.32F.PN**



1  
AIR DISTRIBUTION

**Scheme / Overall dimensions and I/O layout :**

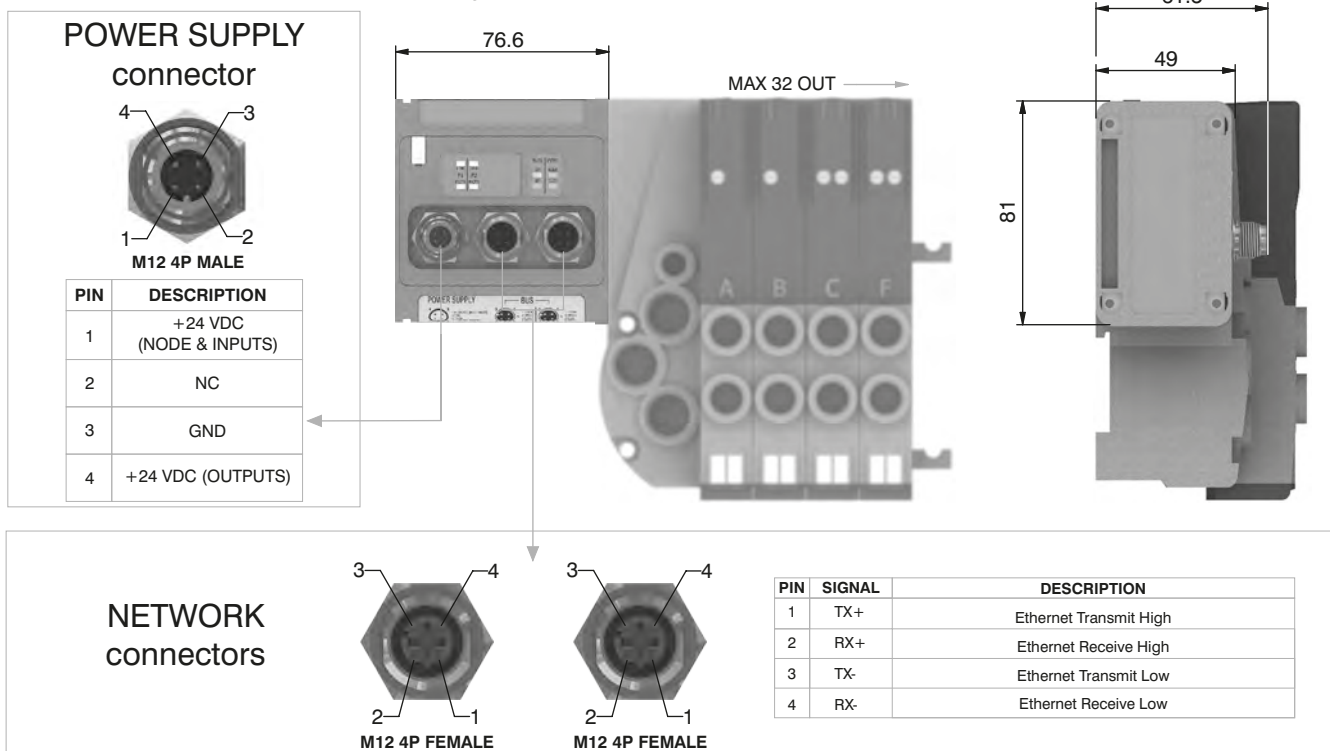

**NETWORK connectors**

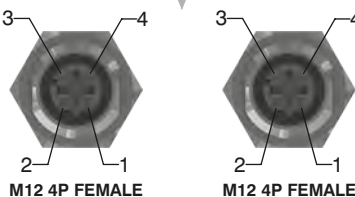

PIN	SIGNAL	DESCRIPTION
1	TX+	Ethernet Transmit High
2	RX+	Ethernet Receive High
3	TX-	Ethernet Transmit Low
4	RX-	Ethernet Receive Low

**Technical characteristics**

	Model	5725.32F.PN
	Specifications	PROFINET IO RT
	Case	Reinforced technopolymer
<b>Power supply</b>	Power supply connection	M12 4P male connector (IEC 60947-5-2)
	Power supply voltage	+24 VDC +/- 10%
	Node consumption (without inputs)	400 mA
	Power supply diagnosis	Green LED PWR / Green LED OUT
<b>Outputs</b>	PNP equivalent outputs	+24 VDC +/- 10%
	Maximum current for output	100 mA
	Maximum output number	32
	Max output simultaneously actuated	32
<b>Network</b>	Network connectors	2 M12 4P female connectors type D (IEC 61076-2-101)
	Baud rate	100 Mbit/s
	Addresses, possible numbers	As an IP address
	Max nodes in net	As an Ethernet Network
	Maximum distance between 2 nodes	100 m
	Bus diagnosis	1 green and 1 red LED for status + 4 LEDs for link & activity
	Configuration file	Available from our web site: <a href="http://www.pneumaxspa.com">http://www.pneumaxspa.com</a>
	IP protection grade	IP65 when assembled
	Temperature range	From 0° to +50° C

**General:**

EtherNet/IP module is directly integrated on Optyma-F solenoid valves manifold via a 37 poles connector, normally used for multipolar cable connection. Optyma-F solenoid valves connected to node must be PNP equivalent (final 02 in ordering code).

The node can be easily installed also on solenoid valves manifold already mounted on equipment.

Module can manage up to 32 solenoid valves, and, in the same time, a max number of 4 Input modules 5225.08F or a max number of 4 Input modules 5225.25F.

The EtherNet/IP module, regardless the number of Input module connected, reports to have connected 8 Input modules.

Regardless of the number of Input modules connected, the manageable solenoid valves are 32.

Node power supply is made by a M12 4P male circular connector.

The separation between node 24 VDC Power supply and outputs 24 VDC allows to switch off the outputs maintaining powered the node and inputs, if present.

Connection to Bus EtherNet/IP is possible via 2 M12 4P type D female circular connectors. These two connectors lead the signal to two different communication ports, so they are not connected in parallel.

The node address is assigned during configuration.

**Ordering code**

**5725.32F.EI**



1 AIR DISTRIBUTION

**Scheme / Overall dimensions and I/O layout :**

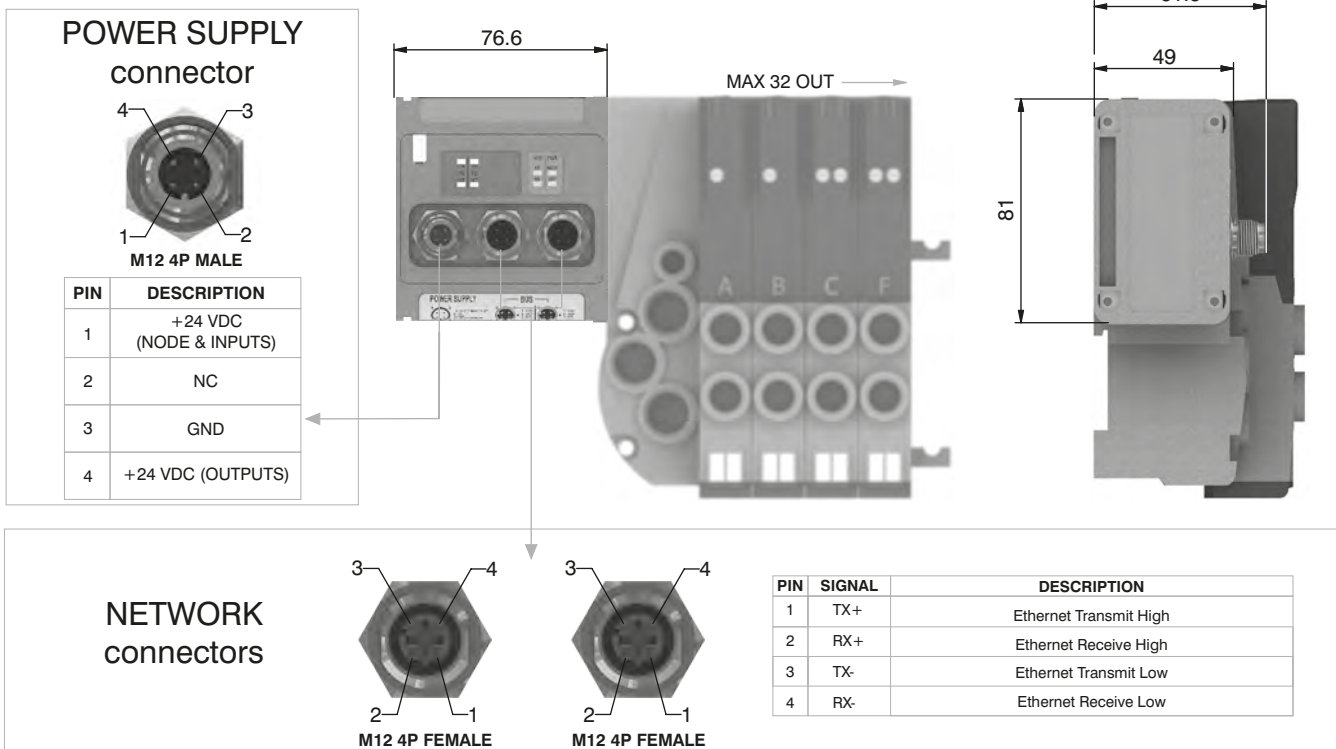

**Technical characteristics**

	Model	5725.32F.EI
	Specifications	The EtherNet/IP Specification
	Case	Reinforced technopolymer
<b>Power supply</b>	Power supply connection	M12 4P male connector (IEC 60947-5-2)
	Power supply voltage	+24 VDC +/- 10%
	Node consumption (without inputs)	400 mA
	Power supply diagnosis	Green LED PWR / Green LED OUT
<b>Outputs</b>	PNP equivalent outputs	+24 VDC +/- 10%
	Maximum current for output	100 mA
	Maximum output number	32
	Max output simultaneously actuated	32
<b>Network</b>	Network connectors	2 M12 4P female connectors type D (IEC 61076-2-101)
	Baud rate	100 Mbit/s
	Addresses, possible numbers	As an IP address
	Max nodes in net	As an Ethernet Network
	Maximum distance between 2 nodes	100 m
	Bus diagnosis	1 green and 1 red LED for status + 4 LEDs for link & activity
	Configuration file	Available from our web site: <a href="http://www.pneumaxspa.com">http://www.pneumaxspa.com</a>
	IP protection grade	IP65 when assembled
	Temperature range	From 0° to +50° C

**General:**

Powerlink module is directly integrated on Optyma-F solenoid valves manifold via a 37 poles connector, normally used for multipolar cable connection.  
Optyma-F solenoid valves connected to node must be PNP equivalent (final 02 in ordering code).

The node can be easily installed also on solenoid valves manifold already mounted on equipment.

Module can manage up to 32 solenoid valves, and, in the same time, a max number of 4 Input modules 5225.08F or a max number of 4 Input modules 5225.25F.

The Powerlink module, regardless the number of Input module connected, reports to have connected 8 Input modules.

Regardless of the number of Input modules connected, the manageable solenoid valves are 32.

Node power supply is made by a M12 4P male circular connector.

The separation between node 24 VDC Power supply and outputs 24 VDC allows to switch off the outputs maintaining powered the node and inputs, if present.

Connection to Bus Powerlink is possible via 2 M12 4P type D female circular connectors. These two connectors lead the signal to two different communication ports, so they are not connected in parallel.

The node address is assigned during configuration.

**Ordering code**

**5725.32F.PL**



1  
AIR DISTRIBUTION

**Scheme / Overall dimensions and I/O layout :**

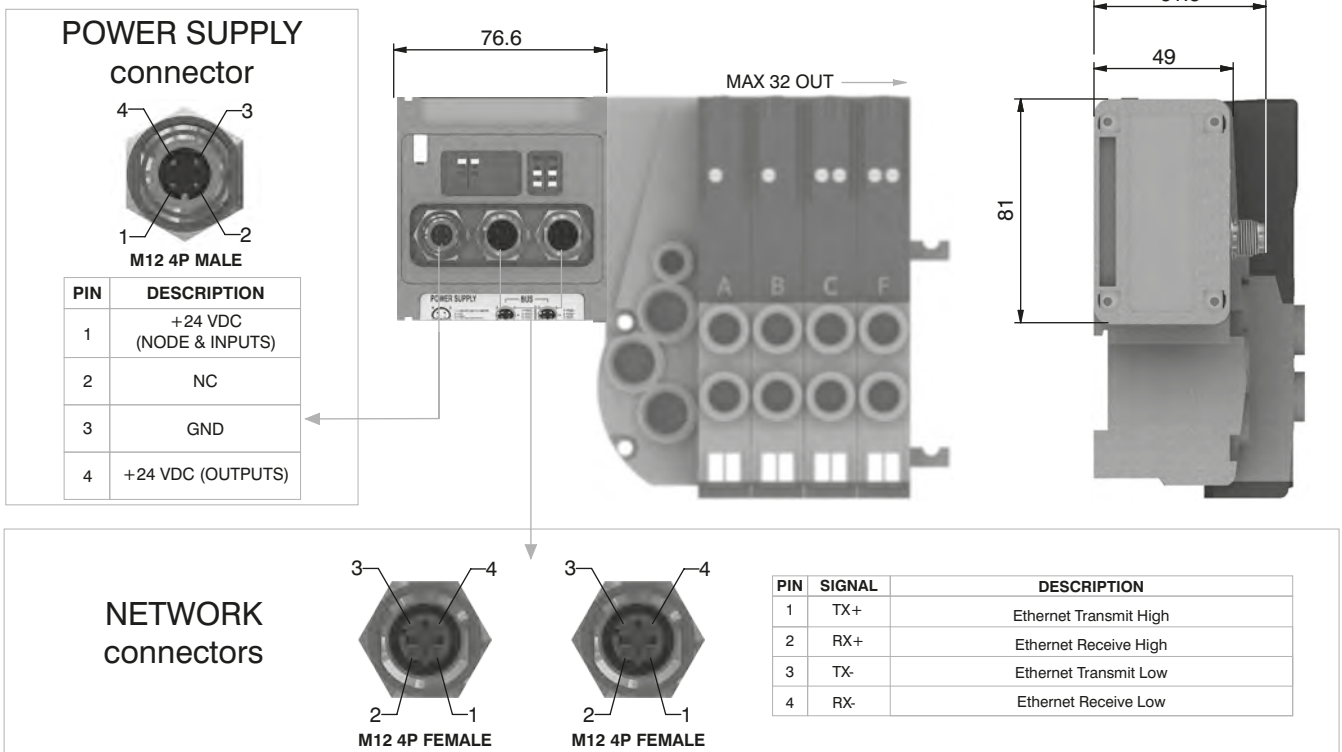

**Technical characteristics**

	Model	5725.32F.PL
	Specifications	Ethernet POWERLINK Communication Profile Specifications
	Case	Reinforced technopolymer
<b>Power supply</b>	Power supply connection	M12 4P male connector (IEC 60947-5-2)
	Power supply voltage	+24 VDC +/- 10%
	Node consumption (without inputs)	400 mA
	Power supply diagnosis	Green LED PWR / Green LED OUT
<b>Outputs</b>	PNP equivalent outputs	+24 VDC +/- 10%
	Maximum current for output	100 mA
	Maximum output number	32
	Max output simultaneously actuated	32
<b>Network</b>	Network connectors	2 M12 4P female connectors type D (IEC 61076-2-101)
	Baud rate	100 Mbit/s
	Addresses, possible numbers	239
	Max nodes in net	240
	Maximum distance between 2 nodes	100 m
	Bus diagnosis	1 green and 1 red LED for status + 2 LEDs for link & activity
	Configuration file	Available from our web site: <a href="http://www.pneumaxspa.com">http://www.pneumaxspa.com</a>
	IP protection grade	IP65 when assembled
Temperature range	From 0° to +50° C	

**General:**

Modbus/TCP module is directly integrated on Optyma-F solenoid valves manifold via a 37 poles connector, normally used for multipolar cable connection.  
 Optyma-F solenoid valves connected to node must be PNP equivalent (final 02 in ordering code).

The node can be easily installed also on solenoid valves manifold already mounted on equipment.

Module can manage up to 32 solenoid valves, and, in the same time, a max number of 4 Input modules 5225.08F or a max number of 4 Input modules 5225.25F.

The Modbus/TCP module, regardless the number of Input module connected, reports to have connected 8 Input modules.

Regardless of the number of Input modules connected, the managable solenoid valves are 32.

Node power supply is made by a M12 4P male circular connector.

The separation between node 24 VDC Power supply and outputs 24 VDC allows to switch off the outputs maintaining powered the node and inputs, if present.

Connection to Bus Modbus/TCP is possible via 2 M12 4P type D female circular connectors. These two connectors lead the signal to two different communication ports, so they are not connected in parallel.

The node address is assigned during configuration.

**Ordering code**

**5725.32F.MT**



**Scheme / Overall dimensions and I/O layout :**

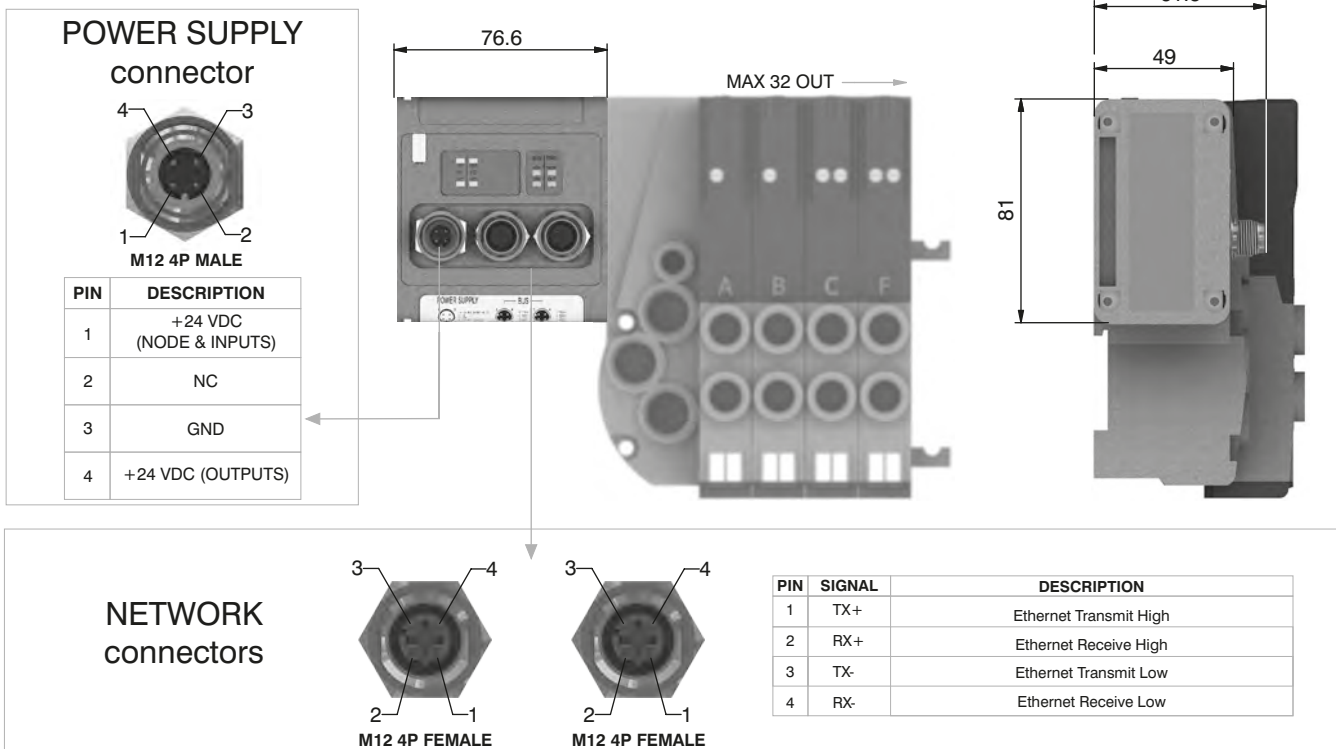

**Technical characteristics**

Model	5725.32F.MT
Specifications	MODBUS Application Protocol Specification V1.1a, June 4, 2004
Case	Reinforced technopolymer
<b>Power supply</b>	Power supply connection: M12 4P male connector (IEC 60947-5-2)
	Power supply voltage: +24 VDC +/- 10%
	Node consumption (without inputs): 400 mA
	Power supply diagnosis: Green LED PWR / Green LED OUT
<b>Outputs</b>	PNP equivalent outputs: +24 VDC +/- 10%
	Maximum current for output: 100 mA
	Maximum output number: 32
	Max output simultaneously actuated: 32
<b>Network</b>	Network connectors: 2 M12 4P female connectors type D (IEC 61076-2-101)
	Baud rate: 100 Mbit/s
	Addresses, possible numbers: 248
	Max nodes in net: 248
	Maximum distance between 2 nodes: 100 m
	Bus diagnosis: 1 green and 1 red LED for status + 2 LEDs for link & activity
	Configuration file: Modbus/TCP nodes don't require configuration file
	IP protection grade: IP65 when assembled
	Temperature range: From 0° to +50° C



**General:**

Modules have 8 connectors M8 3P female.

The Inputs are PNP equivalent 24 VDC ±10%.

To each connector it is possible to plug both 2 wires Inputs (switches, magnetic switches pressure switches, etc.) or 3 wires Inputs (proximity, photocells, electronic sensors, etc).

The maximum current available for all 8 Inputs is 200 mA.

Each module includes a 200 mA self-mending fuse. If a short circuit or a overcharge (overall current >200mA) occur the safety device acts cutting the 24 VDC power supply to all M8 connectors on the module and switching off the green LED PWR. Any other Input module connected to the node will remain powered and will function correctly.

Once the cause of the fault disappears the green LED PWR lights up indicating the ON state and the node will re-start to operate.

The maximum number of Input modules supported is 4.

**Ordering code**

**5225.08F**



1  
AIR DISTRIBUTION

**Scheme / Overall dimensions and I/O layout :**

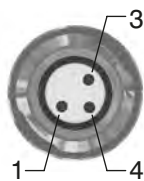
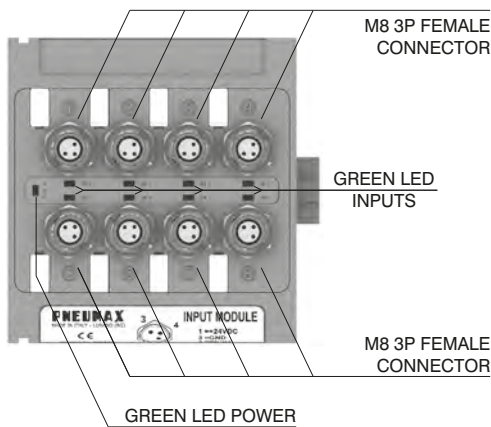

PIN	DESCRIPTION
1	+24 VDC
4	INPUT
3	GND

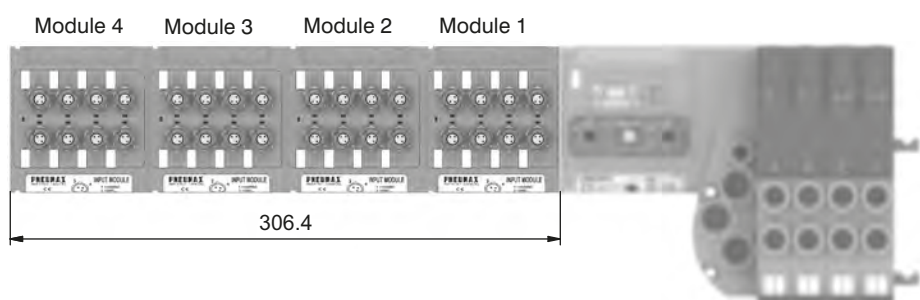
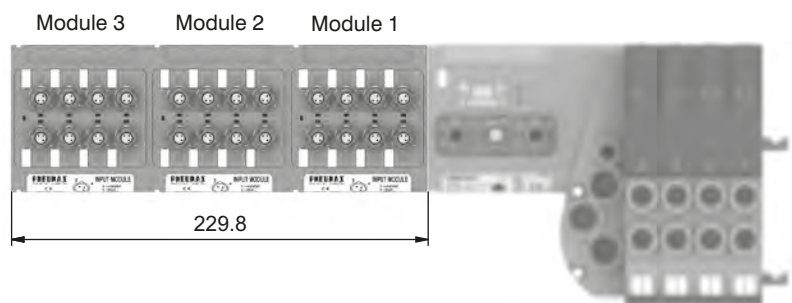
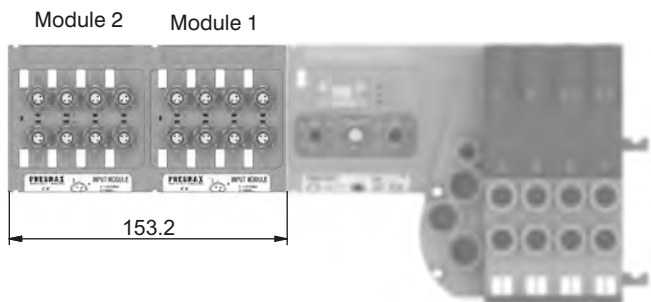
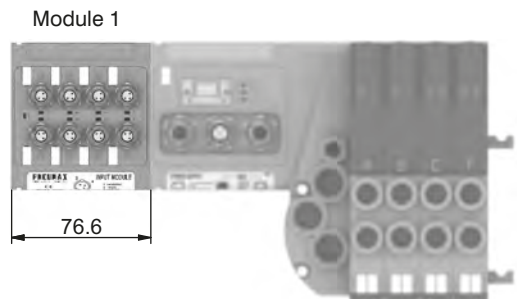

**General :**

Modules are fitted with SUB-D 25 pin female connector.

The Inputs are PNP equivalent 24VDC  $\pm$  10%.

To the connector it is possible to connect both 2 wires Inputs (switches, magnetic switches pressure switches etc.) or 3 wires (proximity, photocells, electronic end of stroke sensors etc).

The maximum current available for all 16 Inputs is 750 mA.

Each module includes a 750 mA self-mending fuse. Should a short circuit or a overcharge (overall current >750mA) occur the safety device intervenes cutting the 24VDC power supply to all pins and switching off the green LED PWR. Any other Input module connected to the node will remain powered and will function correctly.

Once the cause of the fault is removed the green LED lights up indicating the ON state and the node will re-start to operate. This 16 Inputs module is counted as two 8 Inputs modules.

The Maximum number of 16 Inputs modules supported is 2 for CANopen<sup>®</sup>, DeviceNet and EtherCAT<sup>®</sup>.

The Maximum number of 16 Inputs modules supported is 4 for PROFIBUS DP, PROFINET IO RT, EtherNet/IP and Powerlink.

**Ordering code**

**5225.25F**



1 AIR DISTRIBUTION

**Scheme / Overall dimensions and I/O layout :**

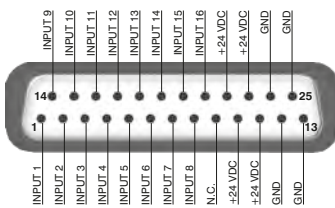
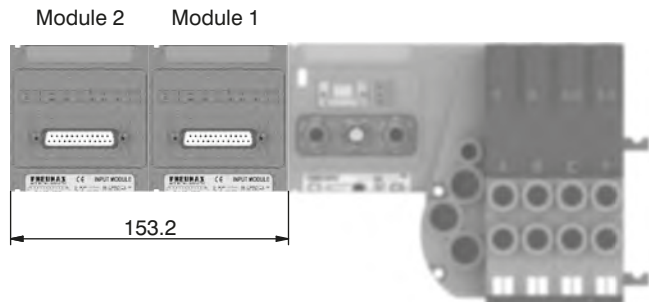
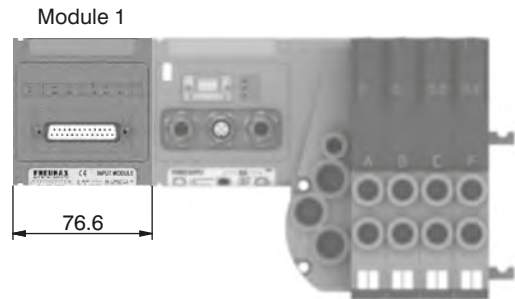
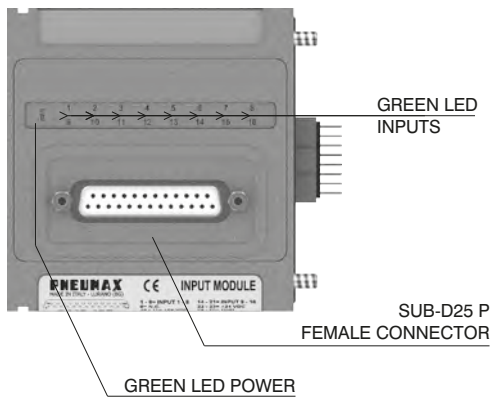



**General :**

This module is fitted with two M8 3 pin female connectors.

With this module is possible to read two analogue inputs (voltage or current).

The inputs are sampled at 12 bit.

For practicality the sampled value is transmitted with 16 bit, of which the four less significant are fixed at zero.

Available models:

- 5225.2T.00F (voltage signal 0 - 10V);
- 5225.2T.01F (voltage signal 0 - 5V);
- 5225.2C.00F (current signal 4 - 20mA);
- 5225.2C.01F (current signal 0 - 20mA).

Each module includes a 300 mA self-mending fuse. Should a short circuit or a overcharge (overall current >300mA) occur the safety device intervenes cutting the 24VDC power supply to all M8 connectors on the module and switching off the green LED PWR. Any other Input module connected to the node will remain powered and will function correctly.

Once the cause of the fault is removed the green LED lights up indicating the ON state and the node will re-start to operate.

This module is counted as four 8 digital Inputs modules.

The Maximum number of 2 analogue Inputs modules supported is 1 for CANopen®, DeviceNet, PROFIBUS DP and EtherCAT®.

The Maximum number of 2 analogue Inputs modules supported is 2 for PROFINET IO RT, EtherNet/IP and Powerlink.

**Scheme / Overall dimensions and I/O layout :**

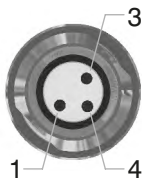
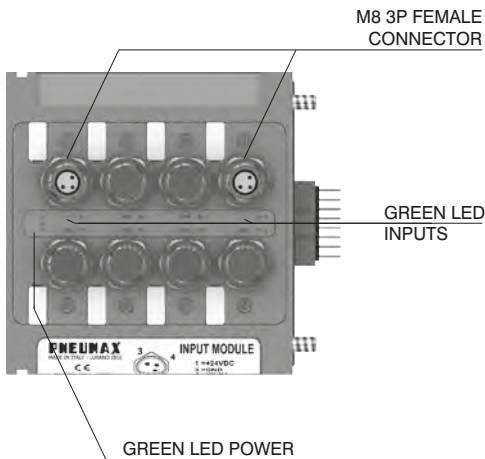

PIN	DESCRIPTION
1	+24 VDC
4	INPUT
3	GND

**Ordering code**

5225.2 \_ . \_ \_ F



Module 1

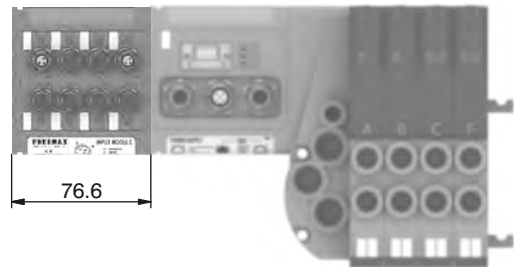

Module 2    Module 1

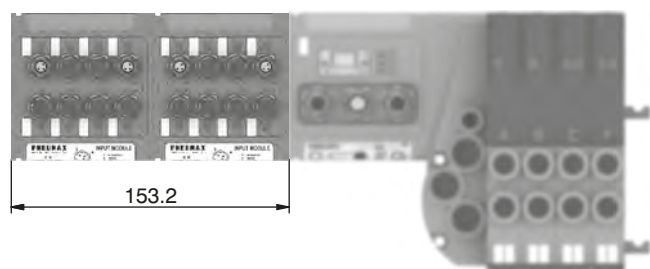

1  
AIR DISTRIBUTION

Socket for Power Supply  
STRAIGHT CONNECTOR  
M12A 4P FEMALE

Ordering code

5312A.F04.00



POWER SUPPLY connector

Upper view  
Slave connector

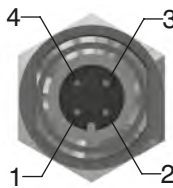

PIN	DESCRIPTION
1	+24 VDC Node
2	
3	0 V
4	+24 VDC Outputs

Socket for Bus CANopen®/DeviceNet  
STRAIGHT CONNECTOR  
M12A 5P FEMALE

Ordering code

5312A.F05.00

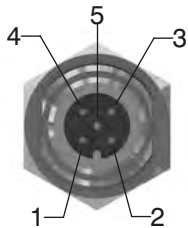

PIN	DESCRIPTION
1	(CAN_SHIELD)
2	(CAN_V+)
3	CAN_GND
4	CAN_H
5	CAN_L

Upper view  
Slave connector

NETWORK connectors

Plug for Bus CANopen®/DeviceNet  
STRAIGHT CONNECTOR  
M12A 5P MALE

Ordering code

5312A.M05.00

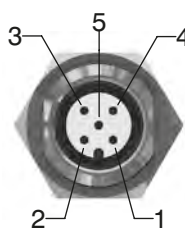

Plug for Bus EtherCAT®,  
PROFINET IO RT,  
EtherNet/IP and Powerlink  
STRAIGHT CONNECTOR M12D 4P MALE

Ordering code

5312D.M04.00



PIN	SIGNAL	DESCRIPTION
1	TX+	Ethernet Transmit High
2	RX+	Ethernet Receive High
3	TX-	Ethernet Transmit Low
4	RX-	Ethernet Receive Low

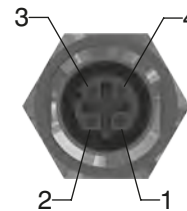

Upper view  
Slave connector

Socket for Bus PROFIBUS DP  
STRAIGHT CONNECTOR  
M12B 5P FEMALE

Ordering code

5312B.F05.00

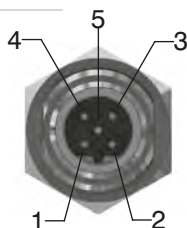

PIN	DESCRIPTION
1	Power Supply
2	A-line
3	DGND
4	B-line
5	SHIELD

Upper view  
Slave connector

Plug for Bus PROFIBUS DP  
STRAIGHT CONNECTOR  
M12B 5P MALE

Ordering code

5312B.M05.00

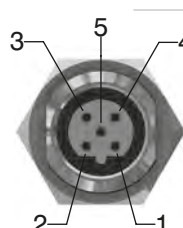

Plug for Input module  
STRAIGHT CONNECTOR  
M8 3P MALE

Ordering code

5308A.M03.00



INPUT connectors

Upper view  
Slave connector

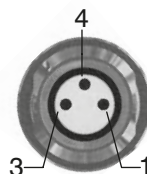

PIN	DESCRIPTION
1	+24 VDC
4	INPUT
3	GND

M12 plug

Ordering code

5300.T12



Plugs

M8 plug

Ordering code

5300.T08







Manifold Layout configuration

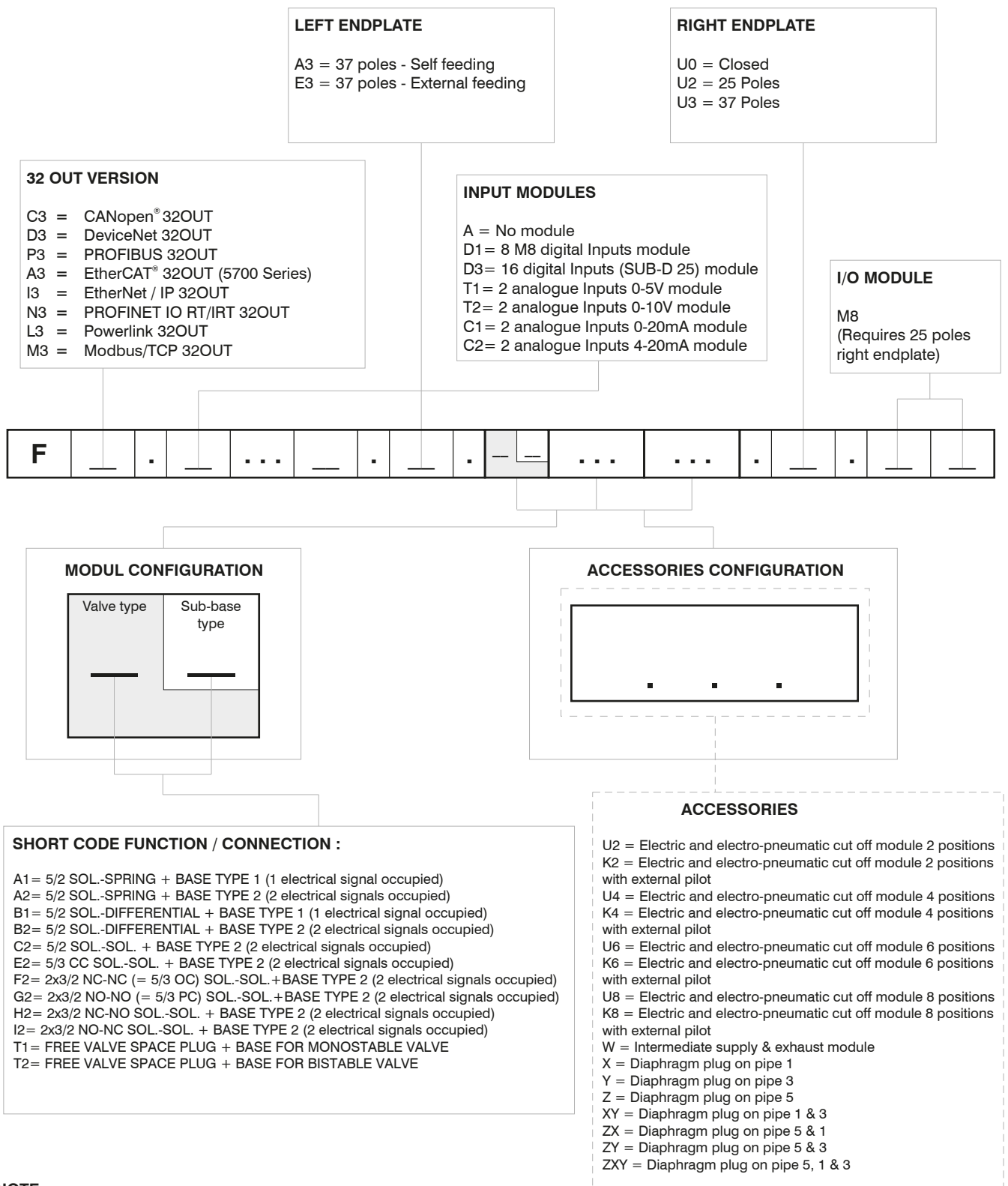

1  
AIR DISTRIBUTION

**NOTE:**

While configuring the manifold always be careful that the maximum number of electrical signals available is 32.  
 The use of monostable valve mounted on a base type 2 ( 2 electrical signals occupied ) causes the loss of one electric signal. In this case the monostable valve can be replaced by a bistable valve. The diaphragms plugs are used to intercept the conduits 1,3 & 5 of the base. If it is necessary to interrupt more than one conduit in the same time then put in line the letters which identifies the position (for exemple : regarding the 3 & 5 conduits, put the Y & Z letters). Should one or more conduits be cut more than one time it is necessary to add the relevant intermediate Supply/Exhaust module.



## Series 2500 "OPTYMA-T"

### General

With the introduction of the "T" configuration of solenoid valves with integrated pneumatic connections fitted directly on the sub base the 2500 series (called OPTYMA) is now richer than ever.

Many technical features make the new product interesting:

- Flow rate of 800 NI/min
- Tie rod system to hold the sub bases together
- All pneumatic connections (push-in) on the same side of the manifold
- Quick mounting of the valve to the base using just one screw
- Possibility to replace the valve without the need to disconnect the connections
- Possibility to use different pressures along the manifold (including vacuum)
- IP65 environmental protection
- Electrical connection directly integrated into the base, 32 electrical signals available (can be used to build up a manifold of 32 monostable valves, 16 bistable valves or any combination within that limit).
- The electrical connection is made via 37 pin D-SUB connector.
- It is also available a 25-pole connector that is able to manage a maximum number of 22 electrical signals.

Possibility to integrate with Field Bus modules CANopen®, PROFIBUS DP, DeviceNet, EtherNet/IP, PROFINET IO RT/IRT, EtherCAT®, Powerlink and Modbus/TCP.

Possibility to connect input modules, even on the base that does not have the Field Bus module. Large use of technopolymer material reduces the overall weight of the manifold.

"Shifting time of pneumatic directional control valves or moving parts, logic devices were measured in accordance to ISO 12238:2001, Pneumatic fluid power-Directional control valves-Measurement of shifting time"

### Main characteristics

- Integrated and optimized electrical connection system.
- IP65 protection degree.
- Only one 19mm size
- Electrical line connections on one side
- Monostable and bistable solenoid valves with the same size dimensions.
- Easy and fast manifold assembly - tie rod system to hold the sub bases together
- Quick coupling connections directly integrated in sub base
- Easy and fast manifold assembling.

### Construction characteristics

Body	Technopolymer
Operators	Technopolymer
Spacers	NBR
Spacer	Technopolymer
Spools	Nickel - plated steel / Technopolymer
Springs	AISI 302 stainless steel
Pistons	Technopolymer
Piston seals	NBR

### Functions

- SV 5/2 MONOSTABLE SOLENOID-SPRING
- SV 5/2 MONOSTABLE SOLENOID-DIFFERENTIAL
- SV 5/2 BISTABLE SOLENOID-SOLENOID
- SV 5/3 C. C. SOLENOID-SOLENOID
- SV 2x3/2 N.C.-N.C. (=5/3 O.C.) SOLENOID-SOLENOID
- SV 2x3/2 N.O.-N.O. (=5/3 P.C.) SOLENOID-SOLENOID
- SV 2x3/2 N.C.-N.O. SOLENOID-SOLENOID

### Technical characteristics

Voltage	24VDC ±10% PNP (NPN and AC on request)
Pilot consumption	1,3 Watt
Pilot working pressure (12-14)	From 3 to 7 bar max.
Valve working pressure [1]	from vacuum up to 10 bar
Operating temperature	-5°C +50°C
Protection degree	IP65
Life (standard operating conditions)	50000000
Fluid	Filtered air. No lubrication needed, if applied it shall be continuous

1 AIR DISTRIBUTION

### Solenoid - Spring

Coding: 2541.52.00.39.

Operational characteristics	
Fluid	Filtered air. No lubrication needed, if applied it shall be continuous
Working pressure (bar)	From vacuum to 10
Pressure range (bar)	3 ÷ 7
Temperature °C	-5 ÷ +50
Flow rate at 6 bar with Δp=1 (NI/min)	750
Response time according to ISO 12238, activation time (ms)	14
Response time according to ISO 12238, deactivation time (ms)	40

VOLTAGE	
	02 = 24 VDC PNP
	12 = 24 VDC NPN
	05 = 24 VAC

Weight 129 g  
SHORT FUNCTION CODE "A"

Shifting time of pneumatic directional control valves or moving parts, logic devices were measured in accordance to ISO 12238:2001

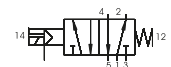
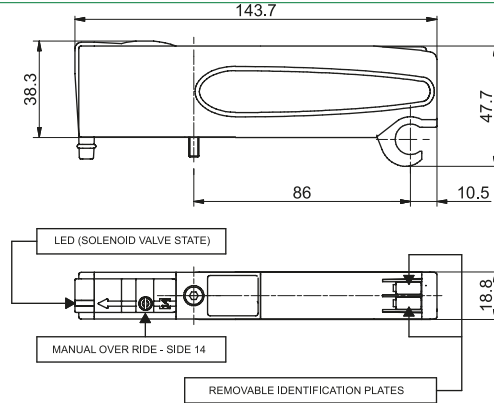

### Solenoid-Differential

Coding: 2541.52.00.36.

Operational characteristics	
Fluid	Filtered air. No lubrication needed, if applied it shall be continuous
Working pressure (bar)	From vacuum to 10
Pressure range (bar)	3 ÷ 7
Temperature °C	-5 ÷ +50
Flow rate at 6 bar with Δp=1 (NI/min)	750
Response time according to ISO 12238, activation time (ms)	20
Response time according to ISO 12238, deactivation time (ms)	29

VOLTAGE	
	02 = 24 VDC PNP
	12 = 24 VDC NPN
	05 = 24 VAC

Weight 126 g  
SHORT FUNCTION CODE "B"

Shifting time of pneumatic directional control valves or moving parts, logic devices were measured in accordance to ISO 12238:2001

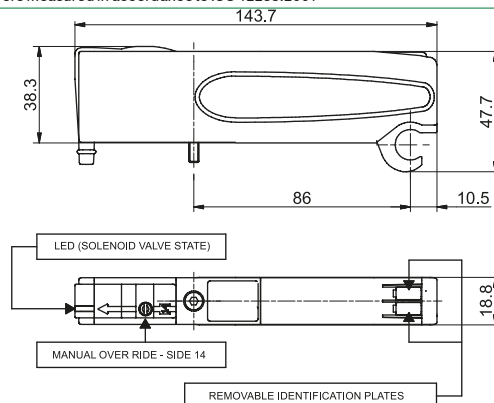

### Solenoid-Solenoid

Coding: 2541.52.00.35.

Operational characteristics	
Fluid	Filtered air. No lubrication needed, if applied it shall be continuous
Working pressure (bar)	From vacuum to 10
Pressure range (bar)	3 ÷ 7
Temperature °C	-5 ÷ +50
Flow rate at 6 bar with Δp=1 (NI/min)	750
Response time according to ISO 12238, activation time (ms)	10
Response time according to ISO 12238, deactivation time (ms)	14

VOLTAGE	
	02 = 24 VDC PNP
	12 = 24 VDC NPN
	05 = 24 VAC

Weight 134 g  
SHORT FUNCTION CODE "C"

Shifting time of pneumatic directional control valves or moving parts, logic devices were measured in accordance to ISO 12238:2001

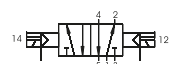
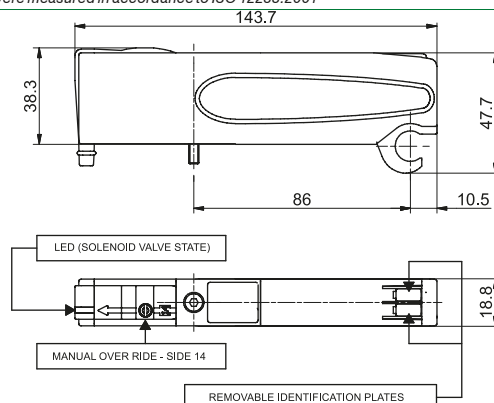

**Solenoid-Solenoid 5/3**

Coding: 2541.53.31.35.

Operational characteristics	
Fluid	Filtered air. No lubrication needed, if applied it shall be continuous
Working pressure (bar)	From vacuum to 10
Pressure range (bar)	3 ÷ 7
Temperature °C	-5 ÷ +50
Flow rate at 6 bar with Δp=1 (NI/min)	600
Response time according to ISO 12238, activation time (ms)	15
Response time according to ISO 12238, deactivation time (ms)	20

VOLTAGE	
	02 = 24 VDC PNP
	12 = 24 VDC NPN
	05 = 24 VAC

Weight 132 g  
SHORT FUNCTION CODE "E"

Shifting time of pneumatic directional control valves or moving parts, logic devices were measured in accordance to ISO 12238:2001

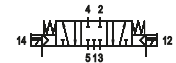
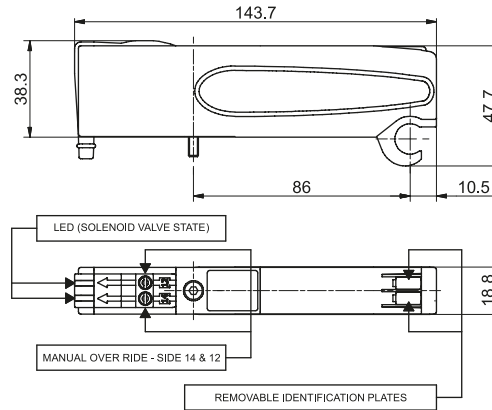

**Solenoid-Solenoid 2x3/2**

Coding: 2541.62. .35.

Operational characteristics	
Fluid	Filtered air. No lubrication needed, if applied it shall be continuous
Working pressure (bar)	From vacuum to 10
Pressure range (bar)	3 ÷ 7
Temperature °C	-5 ÷ +50
Flow rate at 6 bar with Δp=1 (NI/min)	700
Response time according to ISO 12238, activation time (ms)	15
Response time according to ISO 12238, deactivation time (ms)	25

FUNCTION	
	44 = NC-NC (5/3 Open centres)
	55 = NO-NO (5/3 Pressured centres)
	45 = NC-NO (normally closed-normally open)
	54 = NO-NC (normally open-normally closed)

VOLTAGE	
	02 = 24 VDC PNP
	12 = 24 VDC NPN
	05 = 24 VAC

Weight 122 g  
\*Example: If inlet pressure is set at 5bar then pilot pressure must be at least  $P_p = 2,5 + (0,2 * 5) = 3,5 \text{ bar}$

Shifting time of pneumatic directional control valves or moving parts, logic devices were measured in accordance to ISO 12238:2001

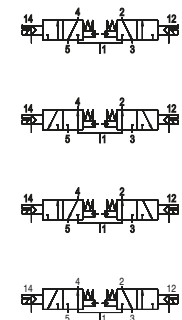
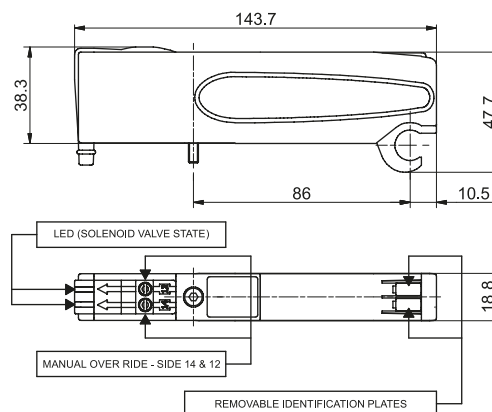

\*Example: If inlet pressure is set at 5bar then pilot pressure must be at least  $P_p = 2,5 + (0,2 * 5) = 3,5 \text{ bar}$

1 AIR DISTRIBUTION

**Right Endplates**

Coding: 2540.03.ⓐ

Operational characteristics	
Fluid	Filtered air. No lubrication needed, if applied it shall be continuous
Working pressure (bar)	From vacuum to 10
Temperature °C	-5 ÷ +50

ELECTRICAL CONNECTION	
ⓐ	00 = Electrical connection
	25P = Connectors 25 poles

Conduit 82/84=DO NOT PRESSURIZE, SOLENOID PILOTS EXHAUST

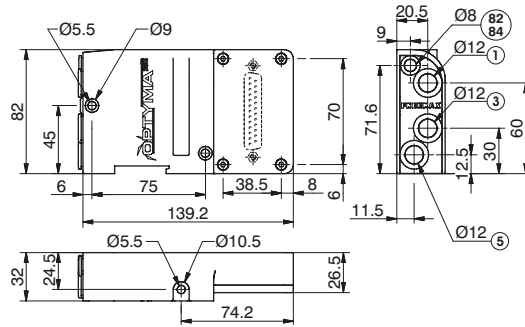

Weight 274 g

**Left Endplates**

Coding: 2540.Ⓥ.ⓐ

Operational characteristics	
Fluid	Filtered air. No lubrication needed, if applied it shall be continuous
Working pressure (bar)	From vacuum to 10
Pressure range (bar)	3 ÷ 7
Temperature °C	-5 ÷ +50

VERSION	
Ⓥ	02 = External feeding
	12 = Self-feeding
ELECTRICAL CONNECTION	
	37P = Connectors 37 poles PNP
	25P = Connectors 25 poles PNP
	37N = Connectors 37 poles NPN
ⓐ	25N = Connectors 25 poles NPN
	37A = Connectors 37 poles AC
	25A = Connectors 25 poles AC



Weight 300 g

2540.02.ⓐ

Left Endplates-External feeding base: 12/14 divided from conduct 1

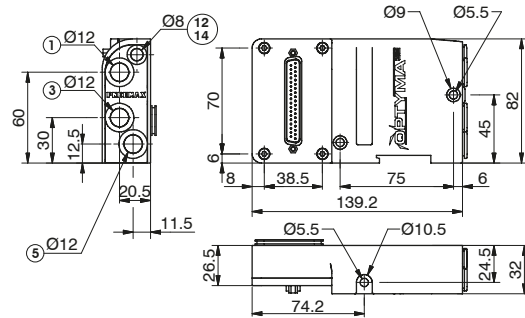

Weight 300 g

2540.12.ⓐ

Left Endplates - Self-feeding Base: 12/14 connected with conduct 1

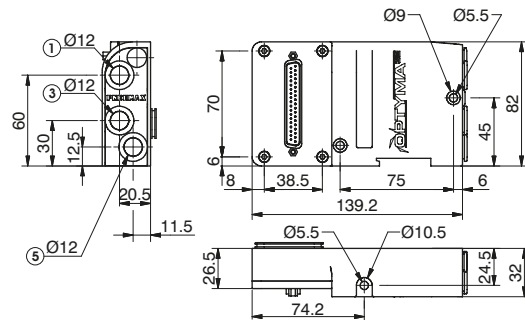

**Closing plate**

Coding: 2530.00

Operational characteristics	
Fluid	Filtered air. No lubrication needed, if applied it shall be continuous
Working pressure (bar)	From vacuum to 10
Temperature °C	-5 ÷ +50

SHORT FUNCTION CODE "T"

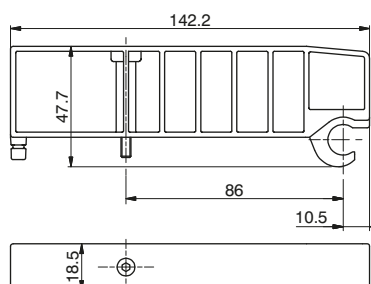

Weight 53,5 g



Modular base

Coding: 254C.01V

Operational characteristics

Fluid	Filtered air. No lubrication needed, if applied it shall be continuous
Working pressure (bar)	From vacuum to 10
Temperature °C	-5 ÷ +50

WORKING PORTS SIZE	
1	= G1/8" female straight cartridge
4	= Cartridge Ø4
6	= Quick fitting tube Ø6
8	= Quick fitting tube Ø8
VERSION	
M	= for Monostable SV
B	= for Bistable SV

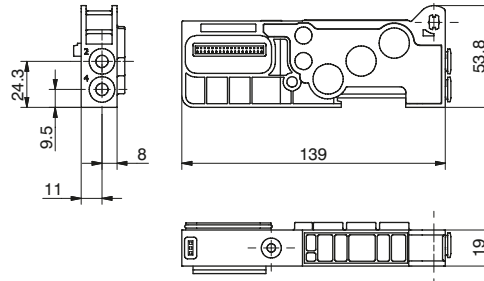

Weight 96,5 g

Intermediate Inlet/Exhaust module

Coding: 2540.10

Operational characteristics

Fluid	Filtered air. No lubrication needed, if applied it shall be continuous
Working pressure (bar)	From vacuum to 10
Temperature °C	-5 ÷ +50

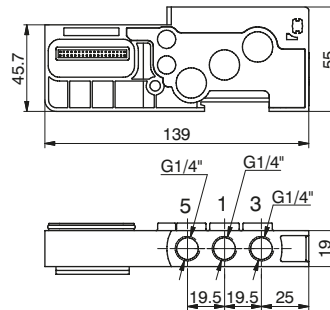

Weight 115 g  
SHORT FUNCTION CODE "W"

Nut

Coding: 2540.KD.00

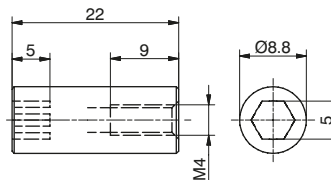

Weight 10 g  
The Kit includes 4 pieces

Extension (1 Position)

Coding: 2540.KP.01

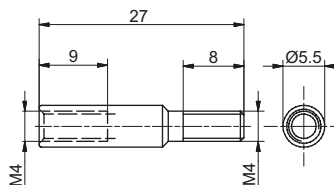

Weight 3,5 g  
The Kit includes 2 pieces

1  
AIR DISTRIBUTION

Set with single tie-rod (max. 32 Solenoid valves)

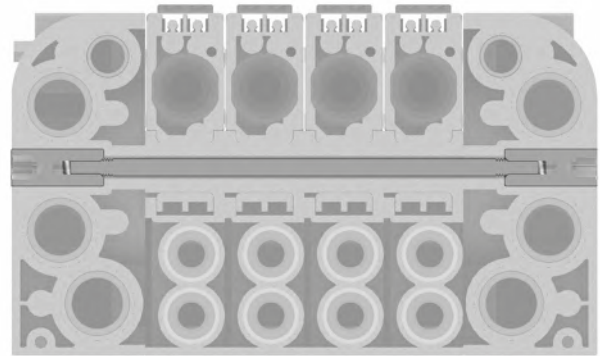
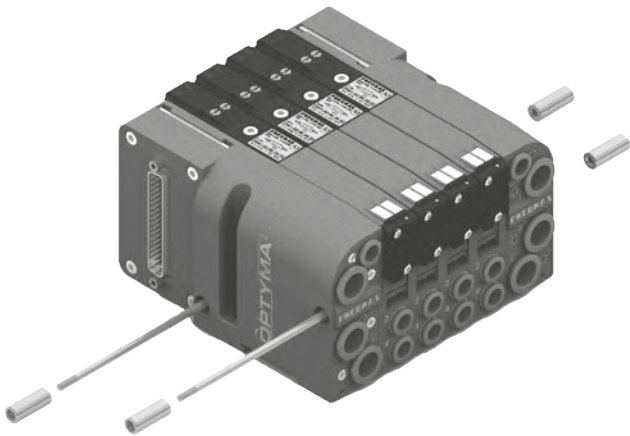

Set with tie-rod, more extension adding a valve

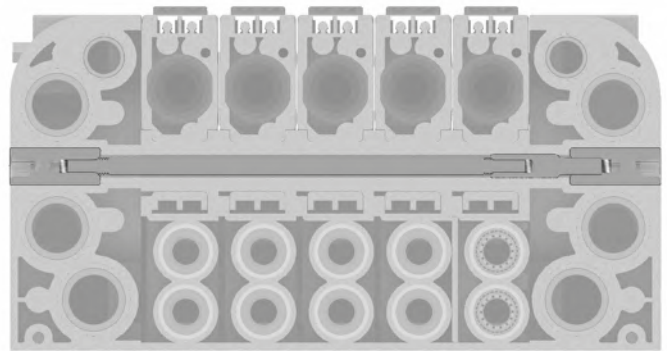
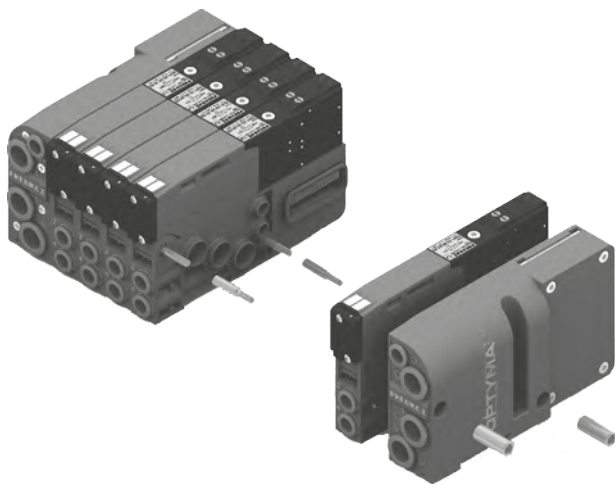

1  
AIR DISTRIBUTION

**General :**

Each Optyma-T manifold allows you to manage 32 command signals for the solenoid valves. Optyma-F serial nodes (CANopen®, DeviceNet, PROFIBUS DP, EtherCAT®, PROFINET IO RT, EtherNet/IP) have a single pin for the power supply of the solenoid valves.

So if you want to interrupt the power supply of one valve it is necessary to interrupt all the valves. The additional power supply module allows you to interrupt at the same time the first 2, 4, 6 or 8 available command signals for the valves after the module itself according to the selected device version. The additional power supply module is particularly useful also when you use control signals that block the valves. This application is effective both with serial management and multi-pole connection of the manifolds.

Furthermore, the electro-pneumatic cut off module allows you to interrupt the air flow that feeds the 12/14 pilots coming from upstream.

A threaded connection port incorporated in the module allows to pneumatically feed each pilots of a limited number of solenoid valves downstream.

This module has the same characteristics of an intermediate supply and exhaust module and fits directly into the Optyma-F series solenoid valve manifolds.

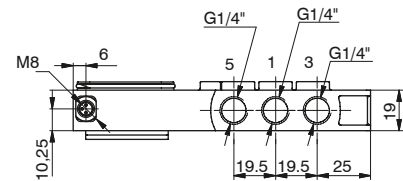
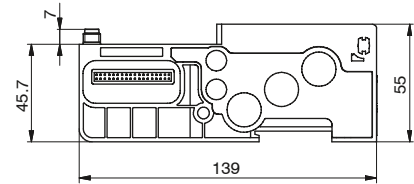
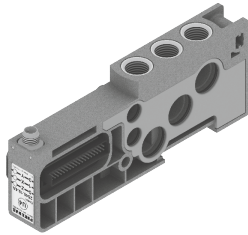

In particular this module is fitted with a M8 3 pins connector: +24V, not connected, GND.

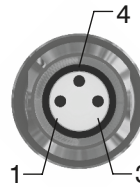

PIN	DESCRIPTION
1	+24 VDC
4	NOT CONNECTED
3	GND

**WORKING PRINCIPLE / SIMPLIFIED FUNCTIONAL DIAGRAM**

This module uses an external power supply (+24VDC) to manage the solenoid valves.

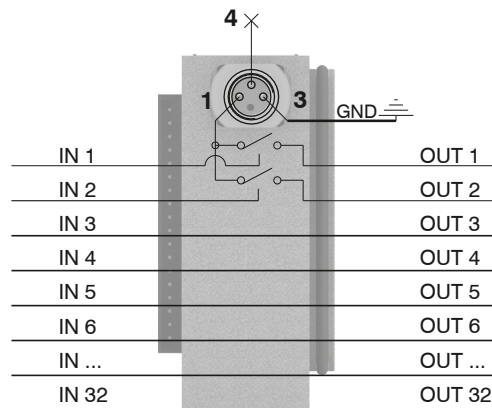

The output signal from serial node / multi-pole connection is used as command signal: when it is high the +24VDC will be present at the module output.

If you want to cut off the power supply to a group of 2 valves it is sufficient to take away the +24VDC provided to the module by the M8 connector.

**Please note:** It is possible to use more modules to interrupt all the command signals, simply by inserting them before the signals to interrupt and after the signals already interrupted.



**Usage examples:**

**EXAMPLE 1:**

Manifold of 12 monostable valves on which you want to interrupt signals 7-8

**Assembly:**

- 6 monostable valves (not interruptible because before the module),
- 1 additional power supply module,
- 6 monostable valves. Please note: the first 2 monostable of these are interruptible by the module, while the following 4 will work correctly managed directly by the corresponding command signals.

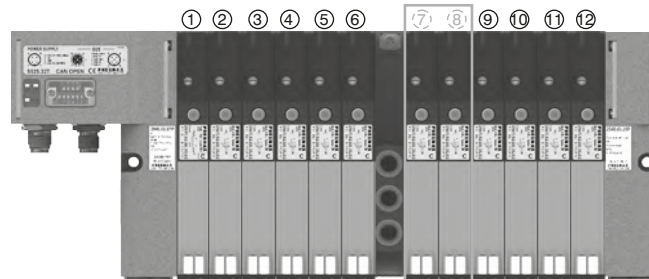

**EXAMPLE 2:**

Manifold of 12 monostable valves on which you want to interrupt signal 9

**Assembly:**

- 8 monostable valves (not interruptible because before the module),
- 1 additional power supply module,
- 1 monostable valve (interruptible),
- 1 closing plate mounted on a monostable base,
- 3 monostable valves (work correctly managed directly by the corresponding command signals).

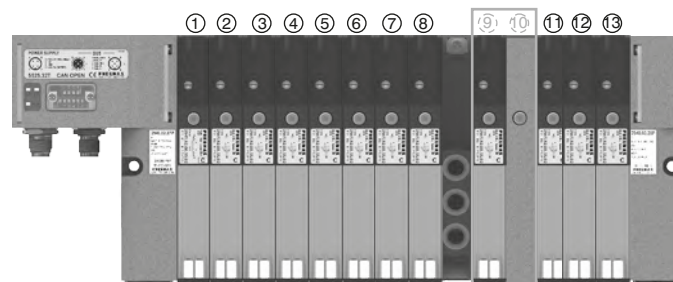

**Please note:** Each additional power supply module interrupts always 2 electrical signals.



If you need to interrupt less than 2 signals you can:

- assemble the valves to interrupt in the last positions of the manifold, so you don't need to worry about the interrupted exceeding signals;
- use a bistable base and mount a monostable valve (for each signal less than the 2 standard);
- use a monostable base and mount a closing plate (for each signal less than the 2 standard).

**EXAMPLE 3:**

Manifold of 7 monostable e 3 bistable valves on which you want to interrupt signals 2-3 and 8-9.

**Assembly:**

- 1 monostable valve (not interruptible because before the module),
- 1 additional power supply module,
- 6 monostable valves.

Please note: the first 2 monostable of these are interruptible by the module, while the following 4 will work correctly managed directly by the corresponding command signals.

- 1 additional power supply module,
- 3 bistable valves.

**Please note:** the first bistable of these valves is interruptible by the module, while the following 2 will work correctly managed directly by the corresponding command signals.

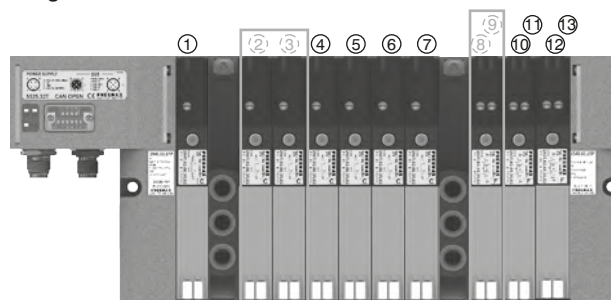

**General :**

Each Optyma-T manifold allows you to manage 32 command signals for the solenoid valves. Optyma-F serial nodes (CANopen®, DeviceNet, PROFIBUS DP, EtherCAT®, PROFINET IO RT, EtherNet/IP) have a single pin for the power supply of the solenoid valves.

So if you want to interrupt the power supply of one valve it is necessary to interrupt all the valves. The additional power supply module allows you to interrupt at the same time the first 2, 4, 6 or 8 available command signals for the valves after the module itself according to the selected device version. The additional power supply module is particularly useful also when you use control signals that block the valves. This application is effective both with serial management and multi-pole connection of the manifolds.

Furthermore, the electro-pneumatic cut off module allows you to interrupt the air flow that feeds the 12/14 pilots coming from upstream.

A threaded connection port incorporated in the module allows to pneumatically feed each pilots of a limited number of solenoid valves downstream.

This module has the same characteristics of an intermediate supply and exhaust module and fits directly into the Optyma-T series solenoid valve manifolds.

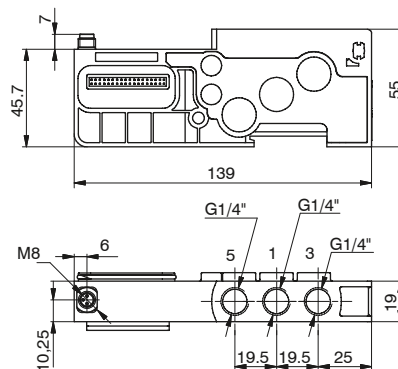
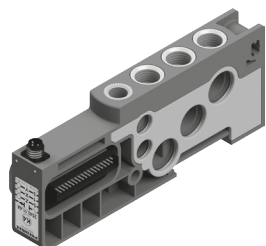

In particular this module is fitted with a M8 3 pins connector: +24V, not connected, GND.

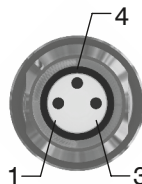

PIN	DESCRIPTION
1	+24 VDC
4	NOT CONNECTED
3	GND

**WORKING PRINCIPLE / SIMPLIFIED FUNCTIONAL DIAGRAM**

This module uses an external power supply (+24VDC) to manage the solenoid valves.

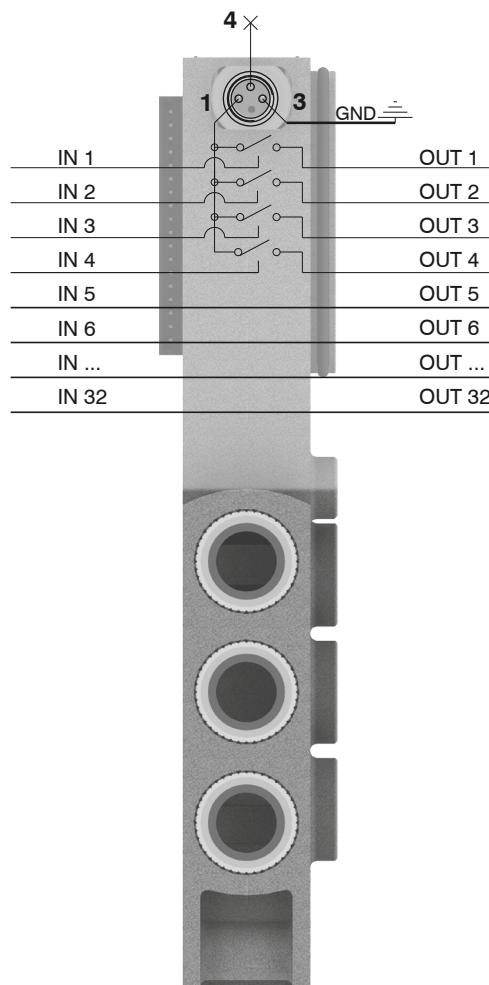

The output signal from serial node / multi-pole connection is used as command signal: when it is high the +24VDC will be present at the module output.

If you want to cut off the power supply to a group of 4 valves it is sufficient to take away the +24VDC provided to the module by the M8 connector.

**Please note:** It is possible to use more modules to interrupt all the command signals, simply by inserting them before the signals to interrupt and after the signals already interrupted.

1 AIR DISTRIBUTION

**Usage examples:**

**EXAMPLE 1:**

Manifold of 12 monostable valves on which you want to interrupt signals 7-8-9-10

**Assembly:**

- 6 monostable valves (not interruptible because before the module),
- 1 additional power supply module,
- 6 monostable valves. Please note: the first 4 monostable of these are interruptible by the module, while the following 2 will work correctly managed directly by the corresponding command signals.

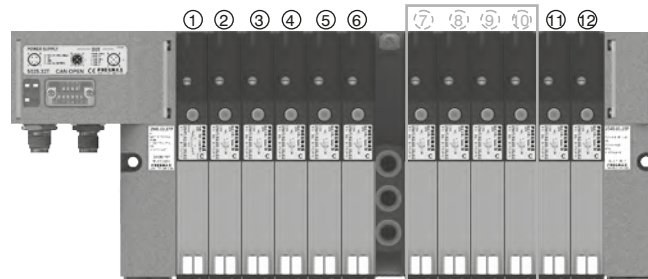

**EXAMPLE 2:**

Manifold of 12 monostable valves on which you want to interrupt signals 7-8-9

**Assembly:**

- 6 monostable valves (not interruptible because before the module),
- 1 additional power supply module,
- 3 monostable valves (interruptible),
- 1 closing plate mounted on a monostable base,
- 3 monostable valves (work correctly managed directly by the corresponding command signals).

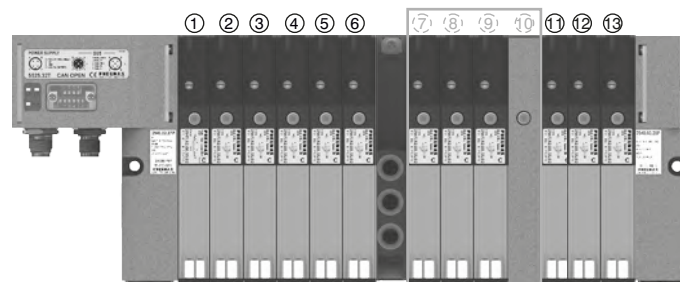

**Please note:** Each additional power supply module interrupts always 4 electrical signals.



If you need to interrupt less than 4 signals you can:

- assemble the valves to interrupt in the last positions of the manifold, so you don't need to worry about the interrupted exceeding signals;
- use a bistable base and mount a monostable valve (for each signal less than the 4 standard);
- use a monostable base and mount a closing plate (for each signal less than the 4 standard).

**EXAMPLE 3:**

Manifold of 7 monostable e 3 bistable valves on which you want to interrupt signals 2-3-4-5 and 8-9-10-11.

**Assembly:**

- 1 monostable valve (not interruptible because before the module),
- 1 additional power supply module,
- 6 monostable valves.

Please note: the first 4 monostable of these are interruptible by the module, while the following 2 will work correctly managed directly by the corresponding command signals.

- 1 additional power supply module,
- 3 bistable valves.

**Please note:** the first 2 bistable of these valves are interruptible by the module, while the following will work correctly managed directly by the corresponding command signals.

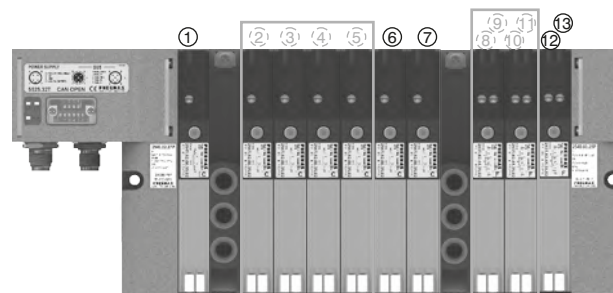

1  
AIR DISTRIBUTION

Coding: 2540.KT.**P**

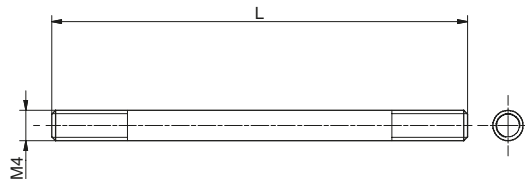

N. POSITIONS	
<b>01</b>	= Nr. 1 Position
<b>02</b>	= Nr. 2 Positions
<b>03</b>	= Nr. 3 positions
<b>04</b>	= Nr. 4 Positions
<b>05</b>	= Nr. 5 positions
<b>06</b>	= Nr. 6 Positions
<b>07</b>	= Nr. 7 positions
<b>P 08</b>	= Nr. 8 Positions
<b>09</b>	= Nr. 9 positions
<b>10</b>	= Nr. 10 Positions
<b>11</b>	= Nr. 11 positions
<b>12</b>	= Nr. 12 Positions
<b>13</b>	= Nr. 13 positions
<b>14</b>	= Nr. 14 Positions
...	
<b>32</b>	= Nr. 32 Positions

**Polyethylene Silencer Series SPL-R**

Coding: SPLR.**D**



TUBE DIAMETER	
<b>D 8</b>	= 8 mm
<b>12</b>	= 12 mm

**Diaphragm plug**

Coding: 2530.17



**Cable complete with connector, 25 Poles IP65**

Coding: 2300.25.**L.C**



CABLE LENGTH	
<b>L 03</b>	= 3 meters
<b>05</b>	= 5 meters
<b>10</b>	= 10 meters
FUNCTION	
<b>F 31</b>	= Closed centres
<b>32</b>	= Open centres
<b>33</b>	= Pressured centres

**Cable complete with connector, 37 Poles IP65**

Coding: 2400.37.**L.C**



CABLE LENGTH	
<b>L 03</b>	= 3 meters
<b>05</b>	= 5 meters
<b>10</b>	= 10 meters
FUNCTION	
<b>F 31</b>	= Closed centres
<b>32</b>	= Open centres
<b>33</b>	= Pressured centres

**Cable complete with connector, 25 Poles IP65**

Coding: 2400.25.**L.25**



CABLE LENGTH	
<b>L 03</b>	= 3 meters
<b>05</b>	= 5 meters
<b>10</b>	= 10 meters



The electrical connection is achieved by a 37 pin connector and can manage up to 32 solenoid pilots. It is also possible use a 25 sub-D pin connector and, in this case, it is possible to manage a maximum of 22 outputs. The management and distribution of the electrical signals between each valve is obtained thanks to an electrical connector which receives the signals from the previous module, uses one, two or none depending on the type, and carries forward to the next module the remaining.

Bistable valves, 5/3 and 2x3/2 valves which have two solenoid pilots built in, use two signals; the first is directed to the pilot side 14 the second to the pilot side 12. Modular bases can be fitted with two type of electrical connector: the monostable version uses only one signal (connected to the pilot side 14) and carries forward the remaining, the bistable version which always uses two signals.

This solution allows the modification of the manifold (replacement of monostable valves without bistable for example) without having to reset the PLC output layout.

On other hand this solution limits the maximum number of valves to 16 when it is used a 37 pin connector or 11 when it is used a 25 pin connector.

Intermediate supply/exhaust module uses an electrical connector directly forwarding signals to the next one without any kind of modification.

This allows the use of intermediate modules in any position of the manifold.

All the electrical signals that have not been used on the manifold can be used placing at the end of the manifold the end plate complete with the 25 sub-D female connector.

The number of available signals depends of the connector used to the type of the left end plate and by the total signals used along the manifold:

37 pin connector            nr of output = 32 – (total of used signals)

25 pin connector            nr of output = 22 – (total of used signals)

Following we show some examples of possible combination and the relative pin assignment.

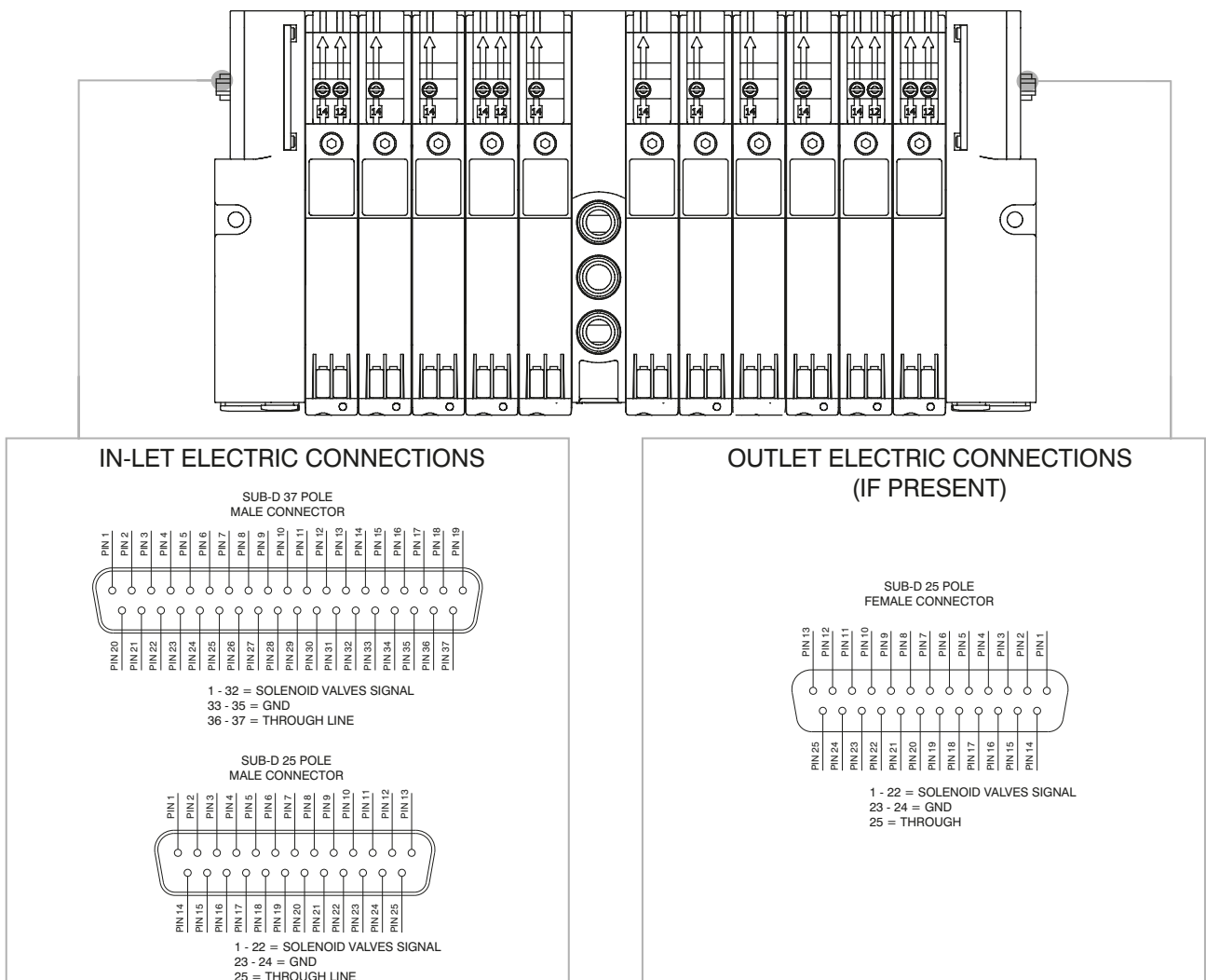

**37 PIN Connector correspondence for valves assembled on mixed bases**

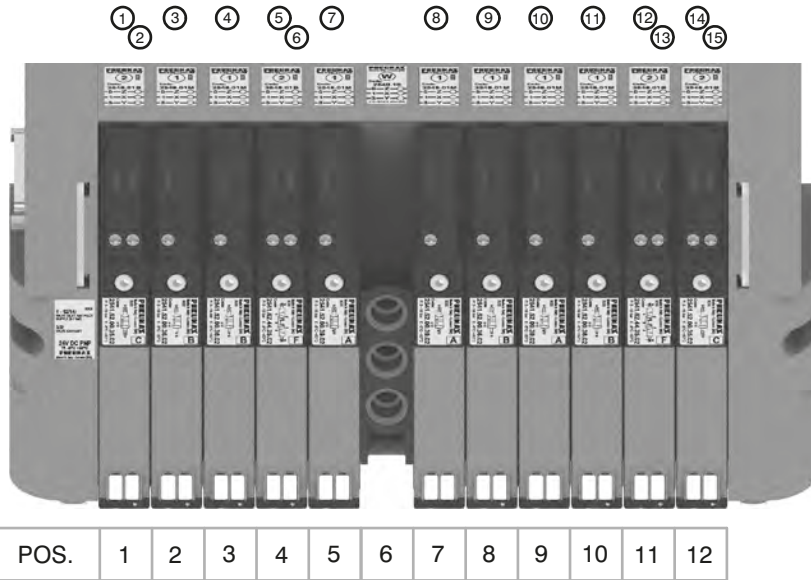

- PIN 1 = PILOT 14 SV POS.1
- PIN 2 = PILOT 12 SV POS.1
- PIN 3 = PILOT 14 SV POS.2
- PIN 4 = PILOT 14 SV POS.3
- PIN 5 = PILOT 14 SV POS.4
- PIN 6 = PILOT 12 SV POS.4
- PIN 7 = PILOT 14 SV POS.5
- PIN 8 = PILOT 14 SV POS.7
- PIN 9 = PILOT 14 SV POS.8
- PIN 10 = PILOT 14 SV POS.9
- PIN 11 = PILOT 14 SV POS.10
- PIN 12 = PILOT 14 SV POS.11
- PIN 13 = PILOT 12 SV POS.11
- PIN 14 = PILOT 14 SV POS.12
- PIN 15 = PILOT 12 SV POS.12

**37 PIN Connector correspondence for manifold mounted on bases for bistable valves**

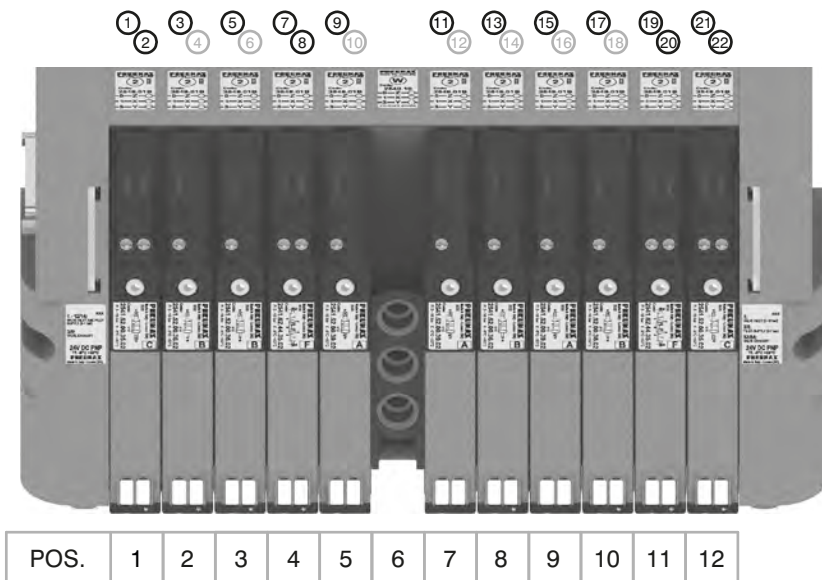

- PIN 1 = PILOT 14 S POS.1
- PIN 2 = PILOT 12 SV POS.1
- PIN 3 = PILOT 14 SV POS.2
- PIN 4 = NOT CONNECTED
- PIN 5 = PILOT 14 SV POS.3
- PIN 6 = NOT CONNECTED
- PIN 7 = PILOT 14 SV POS.4
- PIN 8 = PILOT 12 SV POS.4
- PIN 9 = PILOT 14 SV POS.5
- PIN 10 = NOT CONNECTED
- PIN 11 = PILOT 14 SV POS.7
- PIN 12 = NOT CONNECTED
- PIN 13 = PILOT 14 SV POS.8
- PIN 14 = NOT CONNECTED
- PIN 15 = PILOT 14 SV POS.9
- PIN 16 = NOT CONNECTED
- PIN 17 = PILOT 14 SV POS.10
- PIN 18 = NOT CONNECTED
- PIN 19 = PILOT 14 SV POS.11
- PIN 20 = PILOT 12 SV POS.11
- PIN 21 = PILOT 14 SV POS.12
- PIN 22 = PILOT 12 SV POS.12

**37 PIN Connector correspondence for manifold for 32 position manifold with monostable valves on base**

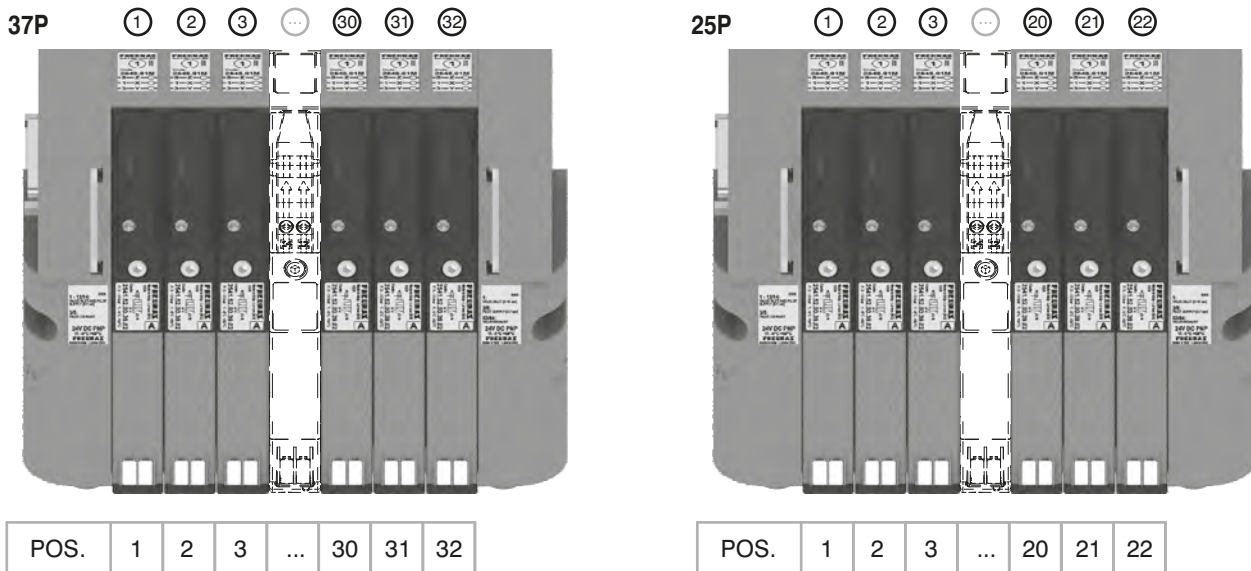

AIR DISTRIBUTION

1



**General :**

Using the 2540.03.25P output terminal it is possible to make any electrical signals not used by valves available on a 25 sub-D female connector at the right end of the manifold.  
It is possible to then join a multi-core cable to link to the next manifold, or connect directly to one or two I/O modules.  
The I/O modules can accept input or output signals, depending upon what is connected.

**Ordering code**

**2540.08T**



1  
AIR DISTRIBUTION

**Please note:** If the manifold is connected by a multi-core connection, each connection can be used as either an input or an output, while if the manifold is connected to a serial node the connections can only be used as an output.

It is possible to connect the manifold to up to two I/O modules.

Each I/O module includes 8 diagnostic LEDs which indicate the presence of an Input / Output signal for each connector.

**Please note:** For an LED to function, a signal of at least +15VDC must be present on pin 4 of the connector. If this signal is lower, the LED will not light, this does not compromise the normal Input / Output function of the unit.

**Overall dimensions and I/O layout :**

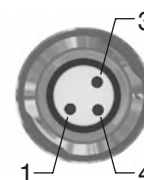
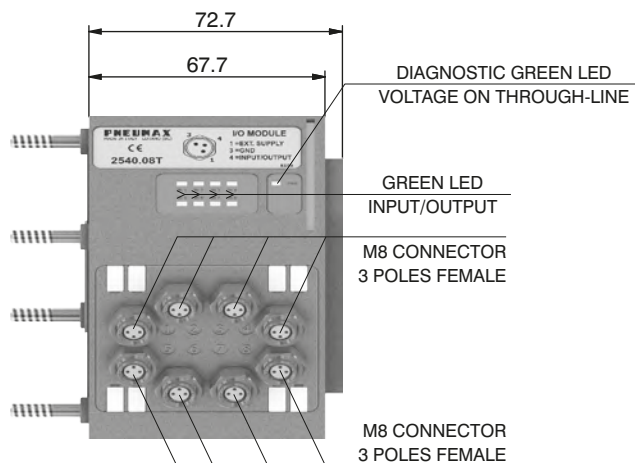

PIN	DESCRIPTION
1	+24 VDC
4	INPUT/OUTPUT
3	GND

**Input features:**

Each connection can accept either two wire (switches, magnetic switches, pressure switches, etc.) or three wire connections (photocells, electronic end of stroke sensors, etc.) If +24VDC is required on at Pin 1 of each connector, it is possible to provide this via the through-line pin of the multi-pole connector.

I.E :

Pin 25 of the 25 pin multi-pole connector (code 2540.02.25P or 2540.12.25P)

Pin 36-37 of the 37 pin multi-pole connector (code 2540.02.37P or 2540.12.37P)

**Output features:**



**Attention:** The output connections are not protected against short-circuit. Please pay attention when wiring (avoid Pin 4 being connected to Pin 3 or Pin 1).

<b>General characteristics</b>	Model	2540.08T
	Case	Reinforced technopolymer
	I/O Connector	M8 connector 3 poles female (IEC 60947-5-2)
	PIN 1 voltage (connector used as Input)	By the user
	PIN 4 voltage diagnosis	Green Led
	Node consumption (Outlets excluded)	7mA per each LED with 24 VDC signal
	Outlets voltage	+23,3 VDC (serial) /by the user (multipolar)
	Input voltage	Depend by the using
	Maximum outlet current	100 mA (serial) / 400 mA (multipolar)
	Maximum Input/Output	8 per module
	Multiconnector max. Current	100 mA
	Connections to manifold	Direct connection to 25 poles connector
	Maximum n. of moduls	2
	Protection degree	IP65 when assembled
Ambient temperature	from -0° to +50° C	

**CORRESPONDENCE BETWEEN MULTI-POLE SIGNAL AND CONNECTOR**

SUB-D TYPE 37 POLE MALE CONNECTOR

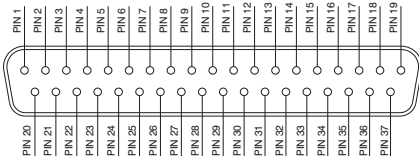

1 - 32 = SIGNALS  
33 - 35 = GND  
36 - 37 = THROUGH LINE

SUB-D TYPE 25 POLE MALE CONNECTOR

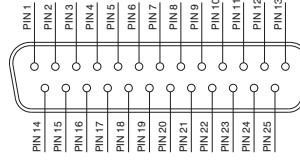

1 - 22 = SIGNALS  
23 - 24 = GND  
25 = THROUGH LINE

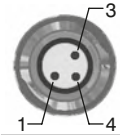

PIN DESCRIPTION	
1	THROUGH LINE
4	SIGNAL
3	GND

**Connection modes:**

The I/O module changes its operation depending on the way the manifold is controlled. There are two possible modes:

- A) Control via multi-pole connection
- B) Control via fieldbus

**A) Control via multi-pole :**

*M8 connector used as Input:*



**Attention:** Voltage applied to each connector is passed to multi-pole connector pin.

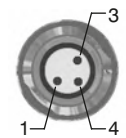

PIN DESCRIPTION	
1	THROUGH LINE
4	SIGNAL
3	GND

In order to use the I/O module, the correct right hand endplate with 25 pole female outlet connector must be used.  
(Code 2540.03.25P).



*M8 connector used as Output:*

Output voltage will be the same as is applied at the multi-pole connector pin.  
The maximum output current depends upon the power unit used, but we recommend no more than 250mA.



**Attention:** Since every cable has a degree of resistance, there will always be a voltage drop depending on the cable's length, sectional area and the current.

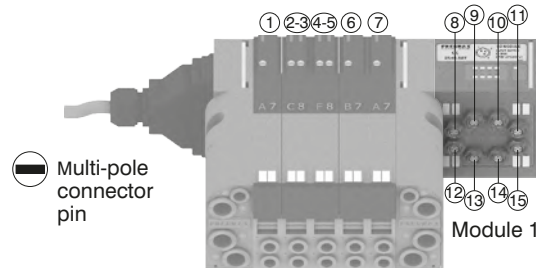

**Attention:** Only one more I/O module can be added.

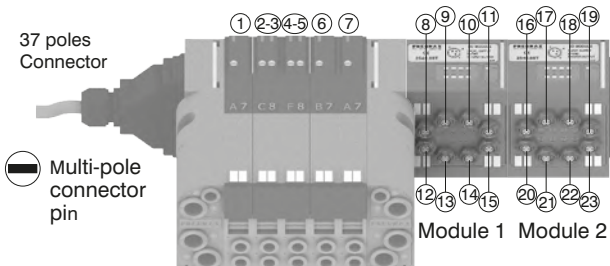

**Attention:** No more additions are possible

**Attention :** Optyma 32-T solenoid valve manifolds permit up to 22 electrical signals that are not used by manifolds to be made available: these signals can be managed by another manifold and / or by I/O modules. The I/O module will manage these unused signals. Connections that are not managing useful signals will remain unconnected.

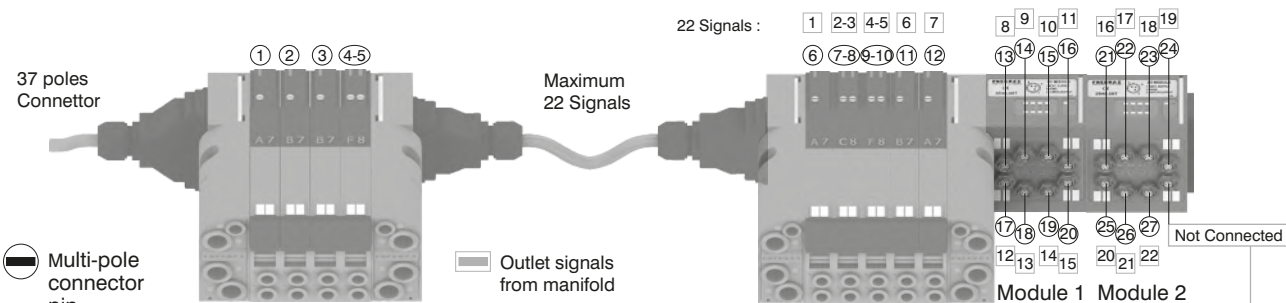

**Attention:** Signal Not connected  
GND Connected  
Through line Connected

**Please note:** this example considers a 37 pin multi-pole connector. The same configuration managed by a 25 pin multi-pole connector will stop at number 22 of multi-pole connector and at number 17 of the manifold. ②①⑦

1 AIR DISTRIBUTION





**Please note:** Optyma 32-T solenoid valve manifolds manage up to 32 signals. If the manifold uses more than 24 signals the I/O module will manage only the remainder. Connections that are not managing useful signals will remain unconnected.

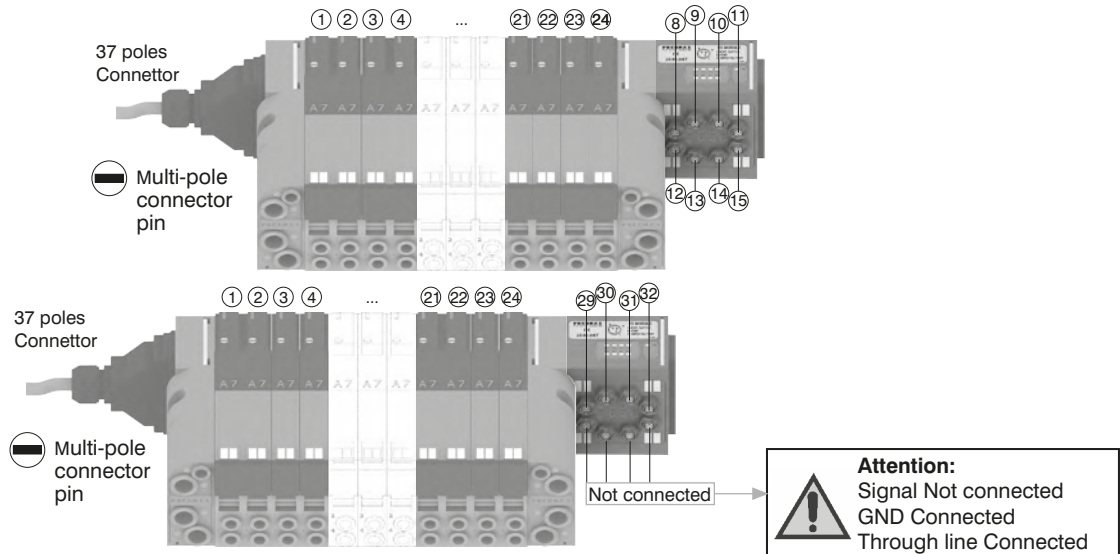

**B) Control via fieldbus:**

With this kind of control the I/O module can only be used as an output. Pin 1 of each connector is not connected. The output voltage will be 0.7V lower than that applied to Pin 4 of the connector.

The maximum output current for each output is 100mA. The correspondence between control byte and each single output depends on how many electrical signals are used by the manifold and by the relative position of the I/O module.

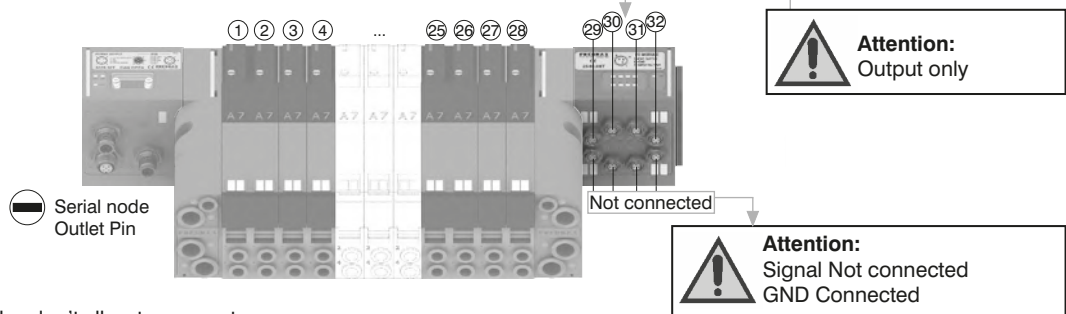
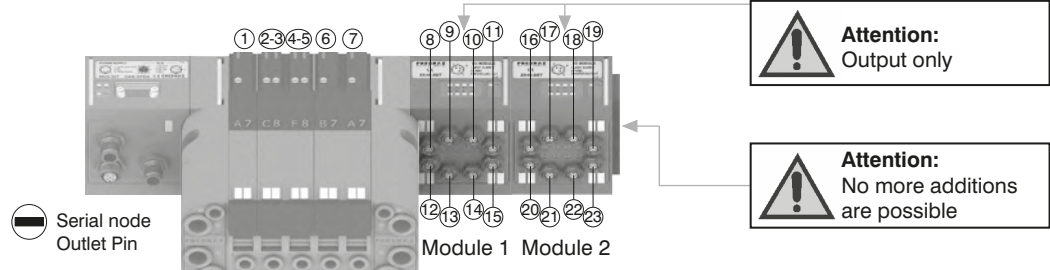
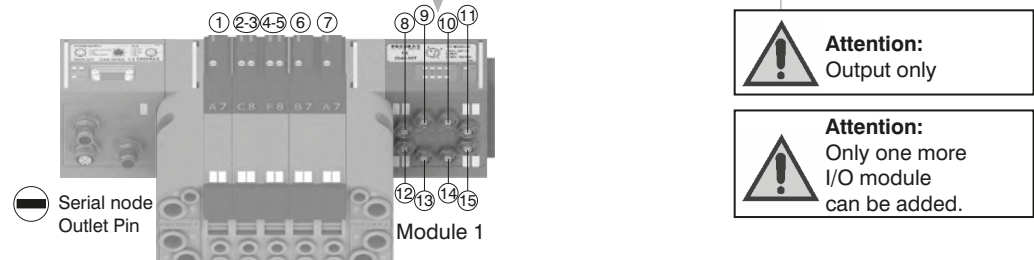
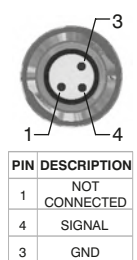

**Please note:** I/O modules don't allow to connect any additional valves manifold after them.

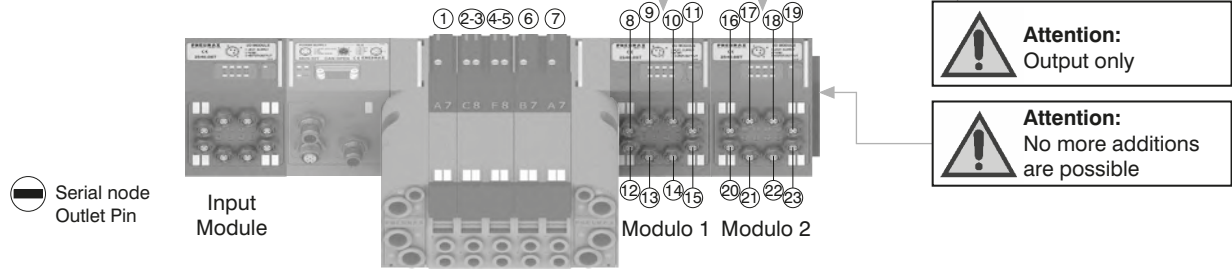

From the top

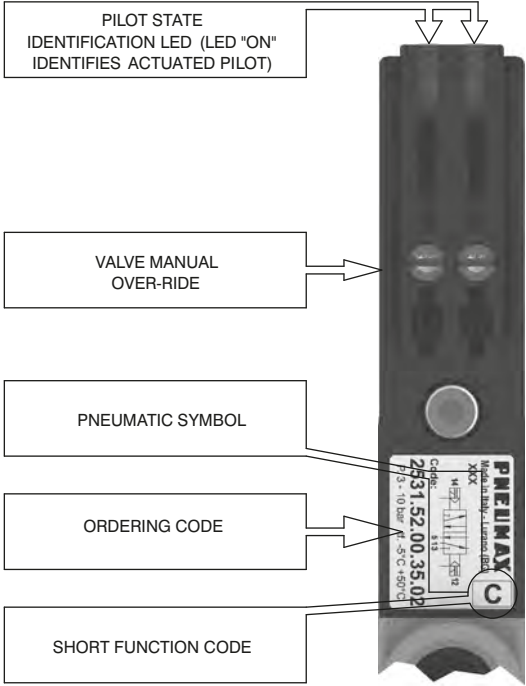
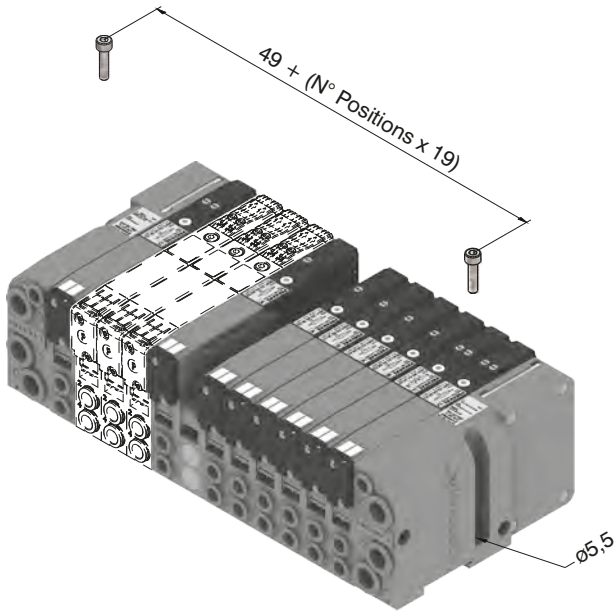

DIN rail fixing

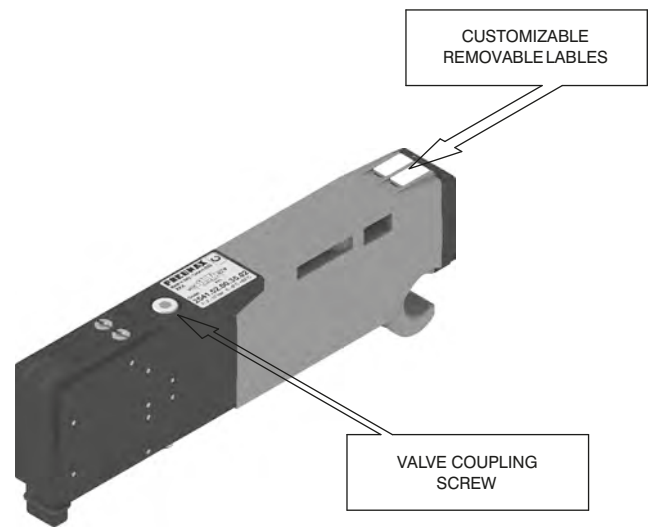
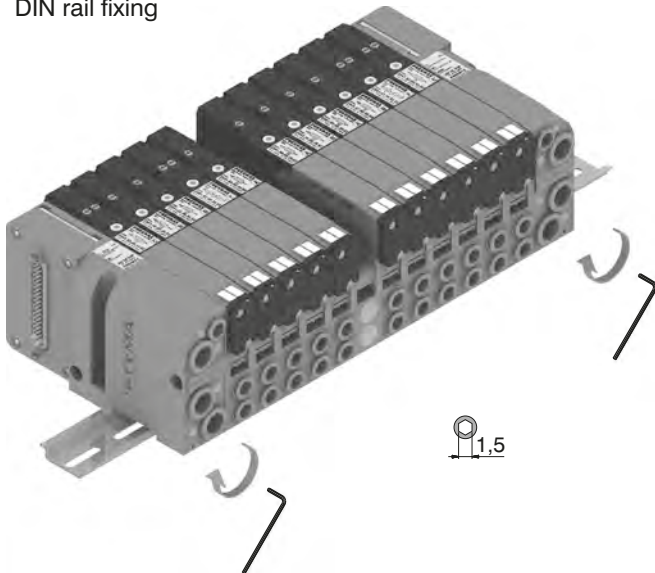

Maximum possible size according to valves seats

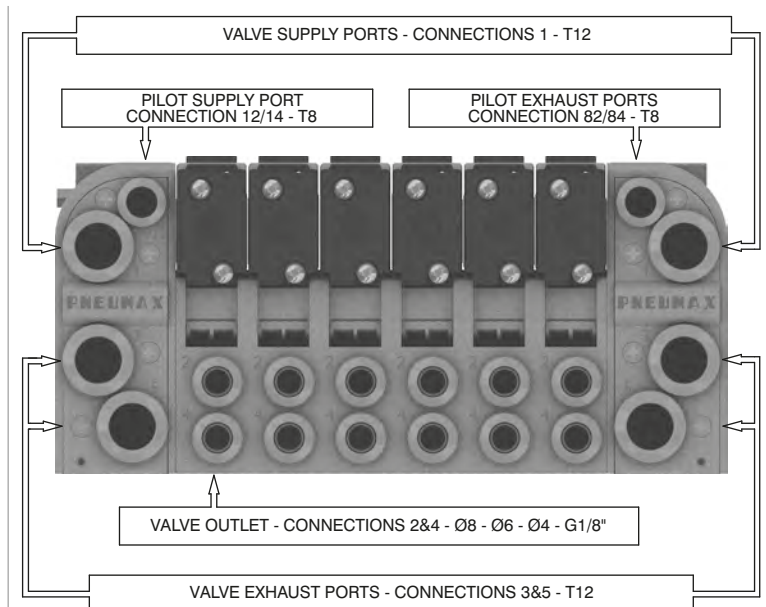
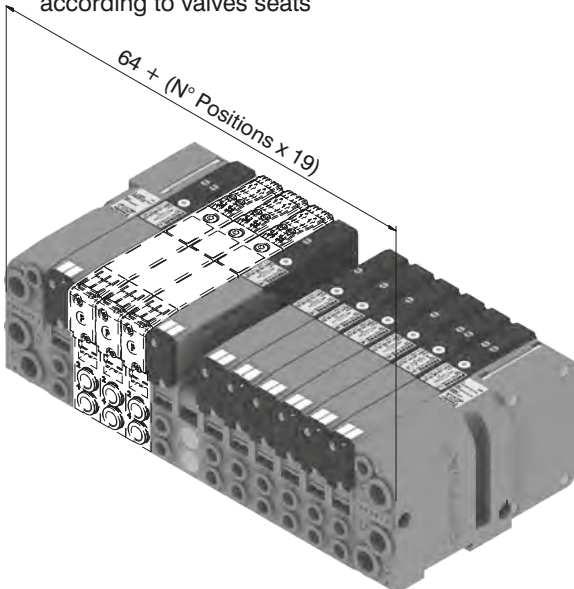

Manual override actuation

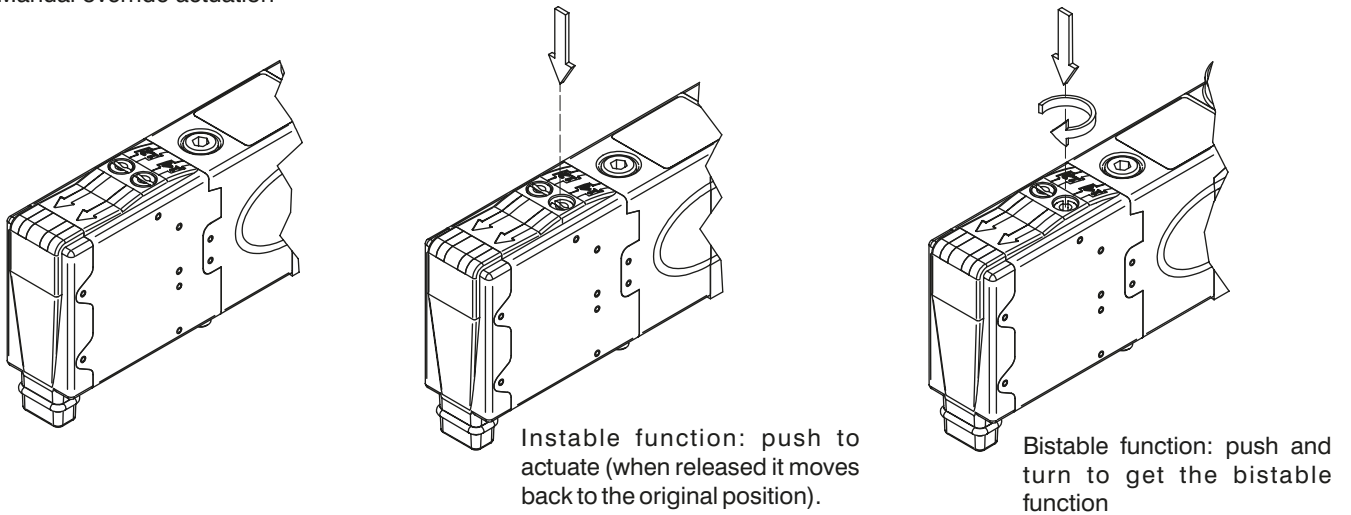

NOTE : It is strongly suggested to replace the original position after using

Valve Installation

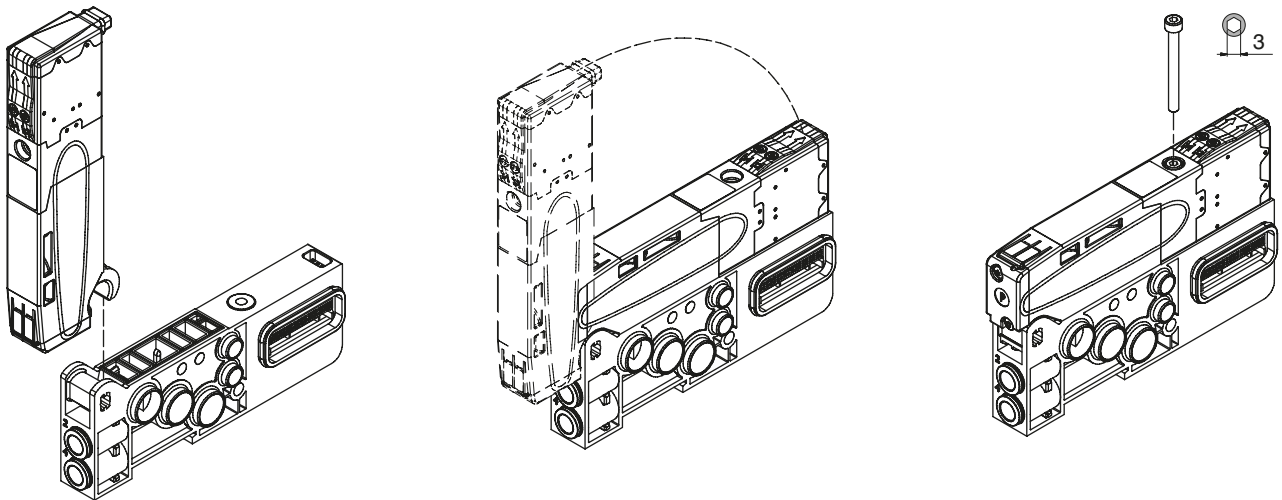

NOTE: Torque moment 1 Nm

Manifold assembly

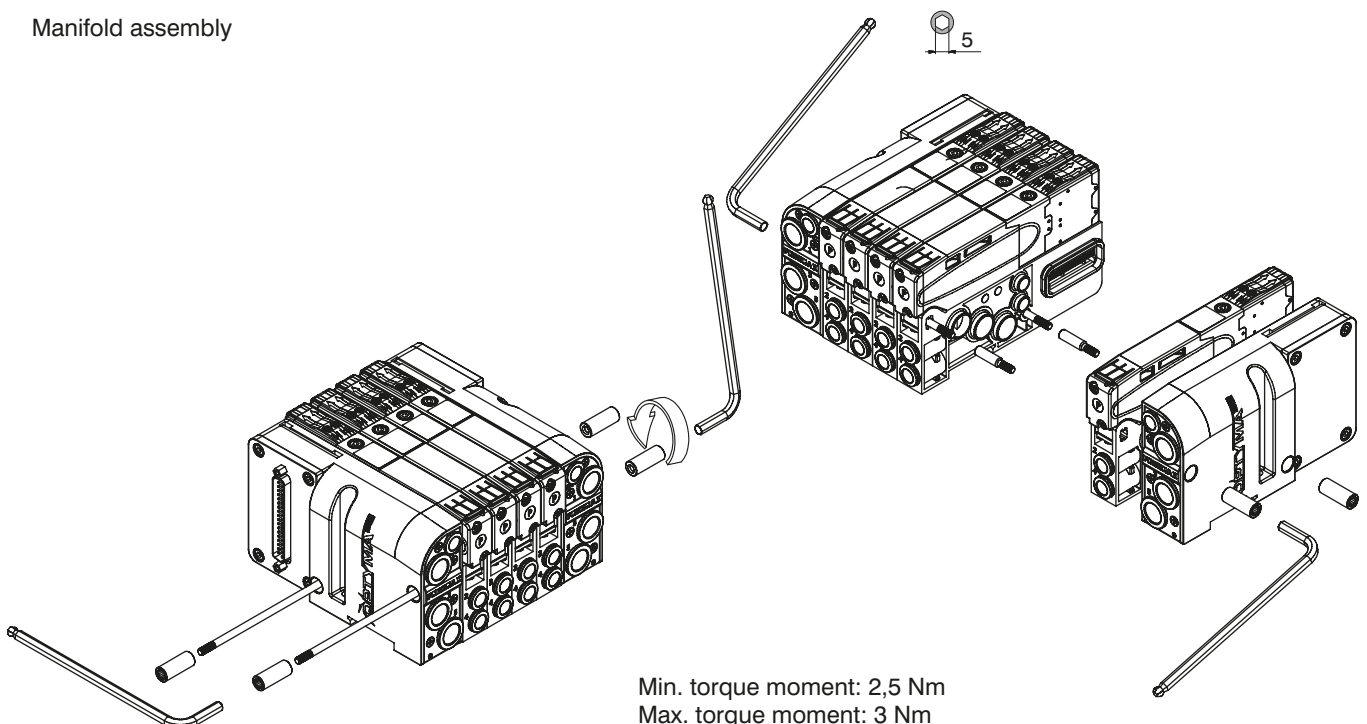

Min. torque moment: 2,5 Nm  
Max. torque moment: 3 Nm

Manifold Layout configuration

1 AIR DISTRIBUTION

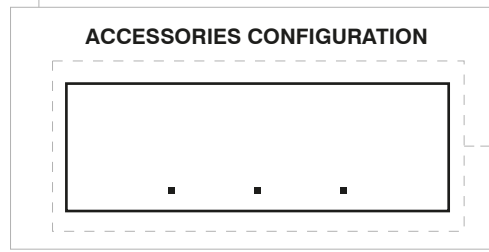
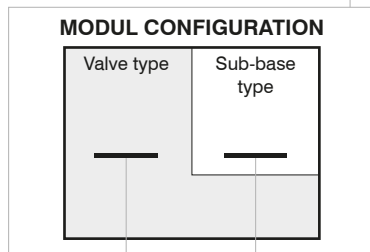
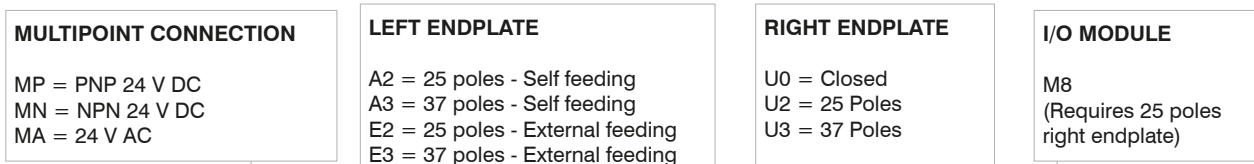

**SHORT CODE FUNCTION / CONNECTION :**

- |  |  |
|--|--|
| A1= 5/2 Sol.-Spring + BASE 1 - CARTR. G1/8" GAS  | F2= 2x3/2 NC-NC (= 5/3 OC) Sol.-Sol. + BASE 2 - CARTR. G1/8" GAS |
| A2= 5/2 Sol.-Spring + BASE 2 - CARTR. G1/8" GAS  | F4= 2x3/2 NC-NC (= 5/3 OC) Sol.-Sol. + BASE 2 - CARTR. Ø4        |
| A3= 5/2 Sol.-Spring + BASE 1 - CARTR. Ø4         | F6= 2x3/2 NC-NC (= 5/3 OC) Sol.-Sol. + BASE 2 - CARTR. Ø6        |
| A4= 5/2 Sol.-Spring + BASE 2 - CARTR. Ø4         | F8= 2x3/2 NC-NC (= 5/3 OC) Sol.-Sol. + BASE 2 - CARTR. Ø8        |
| A5= 5/2 Sol.-Spring + BASE 1 - CARTR. Ø6         | G2= 2x3/2 NO-NO (= 5/3 PC) Sol.-Sol. + BASE 2 - CARTR. G1/8" GAS |
| A6= 5/2 Sol.-Spring + BASE 2 - CARTR. Ø6         | G4= 2x3/2 NO-NO (= 5/3 PC) Sol.-Sol. + BASE 2 - CARTR. Ø4        |
| A7= 5/2 Sol.-Spring + BASE 1 - CARTR. Ø8         | G6= 2x3/2 NO-NO (= 5/3 PC) Sol.-Sol. + BASE 2 - CARTR. Ø6        |
| A8= 5/2 Sol.-Spring + BASE 2 - CARTR. Ø8         | G8= 2x3/2 NO-NO (= 5/3 PC) Sol.-Sol. + BASE 2 - CARTR. Ø8        |
| B1= 5/2 Sol.-Diff. + BASE 1 - CARTR. G1/8" GAS   | H2= 2x3/2 NC-NO Sol.-Sol. + BASE 2 - CARTR. G1/8" GAS            |
| B2= 5/2 Sol.-Diff. + BASE 2 - CARTR. G1/8" GAS   | H4= 2x3/2 NC-NO Sol.-Sol. + BASE 2 - CARTR. Ø4                   |
| B3= 5/2 Sol.-Diff. + BASE 1 - CARTR. Ø4          | H6= 2x3/2 NC-NO Sol.-Sol. + BASE 2 - CARTR. Ø6                   |
| B4= 5/2 Sol.-Diff. + BASE 2 - CARTR. Ø4          | H8= 2x3/2 NC-NO Sol.-Sol. + BASE 2 - CARTR. Ø8                   |
| B5= 5/2 Sol.-Diff. + BASE 1 - CARTR. Ø6          | I2= 2x3/2 NO-NC Sol.-Sol. + BASE 2 - CARTR. G1/8" GAS            |
| B6= 5/2 Sol.-Diff. + BASE 2 - CARTR. Ø6          | I4= 2x3/2 NO-NC Sol.-Sol. + BASE 2 - CARTR. Ø4                   |
| B7= 5/2 Sol.-Diff. + BASE 1 - CARTR. Ø8          | I6= 2x3/2 NO-NC Sol.-Sol. + BASE 2 - CARTR. Ø6                   |
| B8= 5/2 Sol.-Diff. + BASE 2 - CARTR. Ø8          | I8= 2x3/2 NO-NC Sol.-Sol. + BASE 2 - CARTR. Ø8                   |
| C2= 5/2 Sol.-Sol. + BASE 2 - CARTR. G1/8" GAS    | T1= Free valve space plug + BASE 1 - CARTR. G1/8" GAS            |
| C4= 5/2 Sol.-Sol. + BASE 2 - CARTR. Ø4           | T2= Free valve space plug + BASE 2 - CARTR. G1/8" GAS            |
| C6= 5/2 Sol.-Sol. + BASE 2 - CARTR. Ø6           | T3= Free valve space plug + BASE 1 - CARTR. Ø4                   |
| C8= 5/2 Sol.-Sol. + BASE 2 - CARTR. Ø8           | T4= Free valve space plug + BASE 2 - CARTR. Ø4                   |
| E2= 5/3 CC Sol.-Sol. + BASE 2 - CARTR. G1/8" GAS | T5= Free valve space plug + BASE 1 - CARTR. Ø6                   |
| E4= 5/3 CC Sol.-Sol. + BASE 2 - CARTR. Ø4        | T6= Free valve space plug + BASE 2 - CARTR. Ø6                   |
| E6= 5/3 CC Sol.-Sol. + BASE 2 - CARTR. Ø6        | T7= Free valve space plug + BASE 1 - CARTR. Ø8                   |
| E8= 5/3 CC Sol.-Sol. + BASE 2 - CARTR. Ø8        | T8= Free valve space plug + BASE 2 - CARTR. Ø8                   |

**NOTE:**

While configuring the manifold always be careful that the maximum number of electrical signals available is 32. The use of monostable valve mounted on a base type 2 ( 2 electrical signals occupied ) causes the loss of one electric signal. In this case the monostable valve can be replaced by a bistable valve. The diaphragms plugs are used to intercept the conduits 1,3 & 5 of the base. If it is necessary to interrupt more than one conduit in the same time then put in line the letters which identifies the position (for example : regarding the 3 & 5 conduits, put the Y & Z letters). Should one or more conduits be cut more than one time it is necessary to add the relevant intermediate Supply/Exhaust module.

**ACCESSORIES**

- U2 = Electric and electro-pneumatic cut off module 2 positions
- K2 = Electric and electro-pneumatic cut off module 2 positions with external pilot
- U4 = Electric and electro-pneumatic cut off module 4 positions
- K4 = Electric and electro-pneumatic cut off module 4 positions with external pilot
- U6 = Electric and electro-pneumatic cut off module 6 positions
- K6 = Electric and electro-pneumatic cut off module 6 positions with external pilot
- U8 = Electric and electro-pneumatic cut off module 8 positions
- K8 = Electric and electro-pneumatic cut off module 8 positions with external pilot
- W = Intermediate supply & exhaust module
- X = Diaphragm plug on pipe 1
- Y = Diaphragm plug on pipe 33
- Z = Diaphragm plug on pipe 5
- XY = Diaphragm plug on pipe 1 & 3
- ZX = Diaphragm plug on pipe 5 & 1
- ZY = Diaphragm plug on pipe 5 & 3
- ZXY = Diaphragm plug on pipe 5, 1 & 3

Series 2500 OPTYMA-T solenoid valve manifolds managed by multipoint connection are "well tried components"

	<b>Well-tried component</b>	<ul style="list-style-type: none"> <li>- The product is a well-tried product for a safety-related application according to ISO 13849-1.</li> <li>- The relevant basic and well-tried safety principles according ISO 13849-2 for this product are fulfilled.</li> <li>- The suitability of the product for a precise application must be verified and confirmed by the user.</li> </ul>
<b>B<sub>10d</sub></b>	50.000.000	

**General:**

CANopen® module is directly integrated on Optyma-T solenoid valves manifold via a 37 poles connector, normally used for multipolar cable connection.  
Optyma-T solenoid valves connected to node must be PNP equivalent (final 02 in ordering code).

The node can be easily installed also on solenoid valves manifold already mounted on equipment.

Module can manage up to 32 solenoid valves, and, in the same time, a max number of 4 Input modules 5225.08T or a max number of 4 Input modules 5225.12T.

CANopen® module recognizes automatically the presence of the Input modules on power on. Regardless of the number of Input modules connected, the manageable solenoid valves are 32.

Node power supply is made by a M12 4P male circular connector.

The separation between node 24 VDC Power supply and outputs 24 VDC allows to switch off the outputs maintaining powered the node and inputs, if present.

Connection to Bus CANopen® is possible via 2 M12 5P male - female circular connectors; these two are connected in parallel and according to CiA Draft Recommendation 303-1 (V. 1.3 : 30 December 2004).

Transmission speed can be set by 3 dip-switches.

The node address can be set by 6 dip-switches using BCD numeration.

The module includes an internal terminating resistance that can be activated by a dip-switch.

**Ordering code**

**5525.32T**



1

AIR DISTRIBUTION

**Scheme / Overall dimensions and I/O layout :**

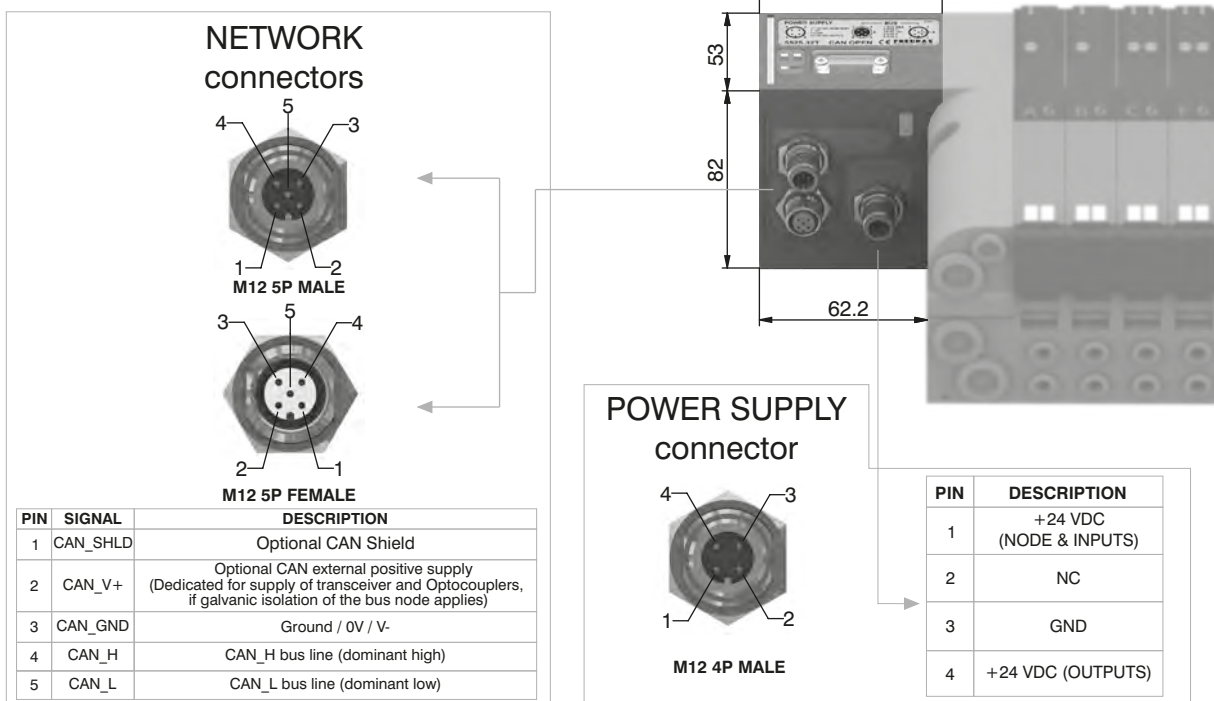

**Technical characteristics**

	Model	5525.32T
	Specifications	CiA Draft Standard Proposal 301 V 4.10 (15 August 2006)
	Case	Reinforced technopolymer
<b>Power supply</b>	Power supply connection	M12 4P male connector (IEC 60947-5-2)
	Power supply voltage	+24 VDC +/- 10%
	Node consumption (without inputs)	30 mA
	Power supply diagnosis	Green LED PWR
<b>Outputs</b>	PNP equivalent outputs	+24 VDC +/- 10%
	Maximum current for each output	100 mA
	Maximum output number	32
	Max output simultaneously actuated	32
<b>Network</b>	Network connectors	2 M12 5P connectors male-female Type A (IEC 60947-5-2)
	Baud rate	10 - 20 - 50 - 125 - 250 - 500 - 800 - 1000 Kbit/s
	Addresses, possible numbers	From 1 to 63
	Max nodes in net	64 (slave + master)
	Bus maximum recommended length	100 m at 500 Kbit/s
	Bus diagnosis	Green LED + Red LED
	Configuration file	Available from our web site: <a href="http://www.pneumaxspa.com">http://www.pneumaxspa.com</a>
	IP protection grade	IP65 when assembled
	Temperature range	From 0° to +50° C

**General:**

DeviceNet module is directly integrated on Optyima-T solenoid valves manifold via a 37 poles connector, normally used for multipolar cable connection.  
 Optyima-T solenoid valves connected to node must be PNP equivalent (final 02 in ordering code).

The node can be easily installed also on solenoid valves manifold already mounted on equipment.

Module can manage up to 32 solenoid valves, and, in the same time, a max number of 4 Input modules 5225.08T or a max number of 4 Input modules 5225.12T.

DeviceNet module recognizes automatically the presence of the Input modules on power on.

Regardless of the number of Input modules connected, the managable solenoid valves are 32.

Node power supply is made by a M12 4P male circular connector.

The separation between node 24 VDC Power supply and outputs 24 VDC allows to switch off the outputs maintaining powered the node and inputs, if present.

Connection to Bus DeviceNet is possible via 2 M12 5P male - female circular connectors; these two are connected in parallel and according to DeviceNet Specifications Volume I, release 2.0.

Transmission speed can be set by 3 dip-switches.

The node address can be set by 6 dip-switches using BCD numeration.

The module includes an internal terminating resistance that can be activated by a dip-switch.

**Ordering code**

**5425.32T**



AIR DISTRIBUTION

**Scheme / Overall dimensions and I/O layout :**

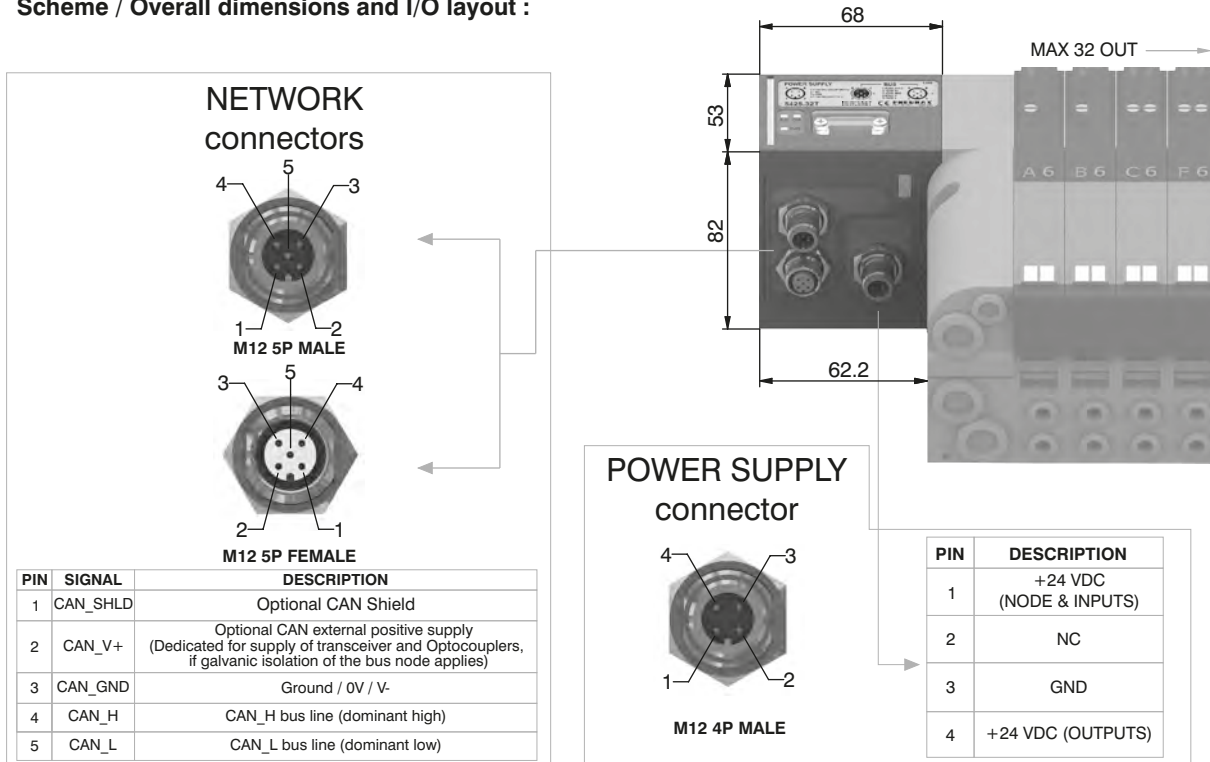

**Technical characteristics**

	Model	5425.32T
	Specifications	DeviceNet Specifications Volume I, release 2.0.
	Case	Reinforced technopolymer
<b>Power supply</b>	Power supply connection	M12 4P male connector (IEC 60947-5-2)
	Power supply voltage	+24 VDC +/- 10%
	Node consumption (without inputs)	30 mA
	Power supply diagnosis	Green LED PWR
<b>Outputs</b>	PNP equivalent outputs	+24 VDC +/- 10%
	Maximum current for each output	100 mA
	Maximum output number	32
	Max output simultaneously actuated	32
<b>Network</b>	Network connectors	2 M12 5P connectors male-female Type A (IEC 60947-5-2)
	Baud rate	125 - 250 - 500 Kbit/s
	Addresses, possible numbers	From 1 to 63
	Max nodes in net	64 (slave + master)
	Bus maximum recommended length	100 m at 500 Kbit/s
	Bus diagnosis	Green LED + Red LED
	Configuration file	Available from our web site: <a href="http://www.pneumaxspa.com">http://www.pneumaxspa.com</a>
	IP protection grade	IP65 when assembled
	Temperature range	From 0° to +50° C



**General:**

PROFIBUS DP module is directly integrated on Optyma-T solenoid valves manifold via a 37 poles connector, normally used for multipolar cable connection.  
Optyma-T solenoid valves connected to node must be PNP equivalent (final 02 in ordering code).  
The node can be easily installed also on solenoid valves manifold already mounted on equipment.

Module can manage up to 32 solenoid valves, and, in the same time, a max number of 8 Input modules 5225.08T or a max number of 8 Input modules 5225.12T.

PROFIBUS DP module recognizes automatically the presence of the Input modules on power on. Regardless of the number of Input modules connected, the manageable solenoid valves are 32.

Node power supply is made by a M12 4P male circular connector.

The separation between node 24 VDC Power supply and outputs 24 VDC allows to switch off the outputs maintaining powered the node and inputs, if present.

Connection to Bus PROFIBUS DP is possible via 2 M12 type B 5P male - female circular connectors; these two are connected in parallel and according to PROFIBUS Interconnection Technology (Version 1.1 : August 2001).

The node address can be set using BCD numeration: 4 dip-switches for the units and 4 dip-switches for the tens.

The module includes an internal terminating resistance that can be activated by 2 dip-switches.

**Ordering code**

**5325.32T**

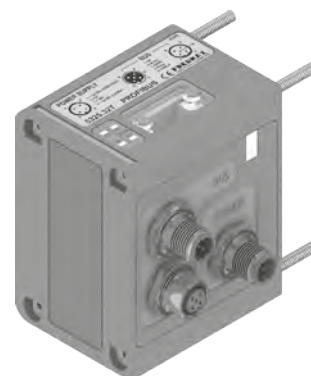

1  
AIR DISTRIBUTION

**Scheme / Overall dimensions and I/O layout :**

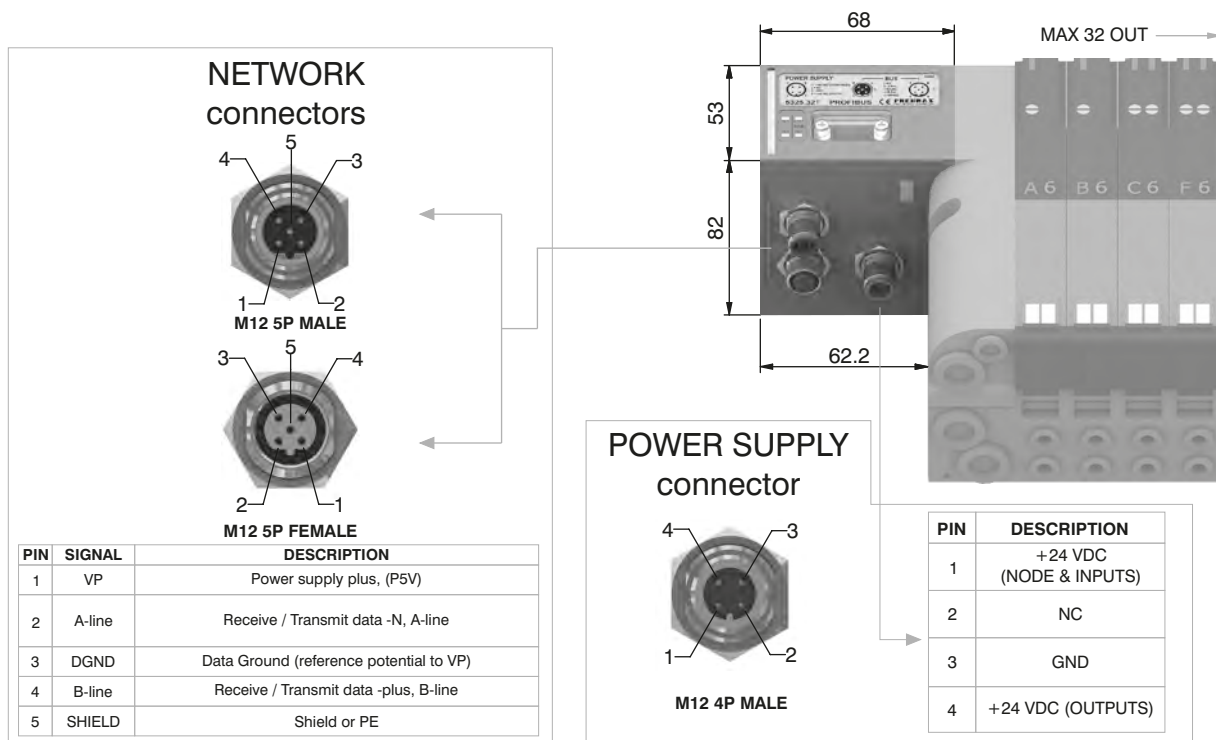

PIN	SIGNAL	DESCRIPTION
1	VP	Power supply plus, (P5V)
2	A-line	Receive / Transmit data -N, A-line
3	DGND	Data Ground (reference potential to VP)
4	B-line	Receive / Transmit data -plus, B-line
5	SHIELD	Shield or PE

PIN	DESCRIPTION
1	+24 VDC (NODE & INPUTS)
2	NC
3	GND
4	+24 VDC (OUTPUTS)

**Technical characteristics**

	Model	5325.32T
	Specifications	PROFIBUS DP
	Case	Reinforced technopolymer
<b>Power supply</b>	Power supply connection	M12 4P male connector (IEC 60947-5-2)
	Power supply voltage	+24 VDC +/- 10%
	Node consumption (without inputs)	50 mA
	Power supply diagnosis	Green LED PWR / Green LED OUT
<b>Outputs</b>	PNP equivalent outputs	+24 VDC +/- 10%
	Maximum current for each output	100 mA
	Maximum output number	32
	Max output simultaneously actuated	32
<b>Network</b>	Network connectors	2 M12 5P male-female connectors Type B
	Baud rate	9,6 - 19,2 - 93,75 - 187,5 - 500 - 1500 - 3000 - 6000 - 12000 Kbit/s
	Addresses, possible numbers	From 1 to 99
	Max nodes in net	100 (slave + master)
	Bus maximum recommended length	100 m at 12 Mbit/s - 1200 m at 9,6 Kbit/s
	Bus diagnosis	Green LED + Red LED
	Configuration file	Available from our web site: <a href="http://www.pneumaxspa.com">http://www.pneumaxspa.com</a>
	IP protection grade	IP65 when assembled
	Temperature range	From 0° to +50° C

**General:**

EtherCAT® module is directly integrated on Optyima-T solenoid valves manifold via a 37 poles connector, normally used for multipolar cable connection. Optyima-T solenoid valves connected to node must be PNP equivalent (final 02 in ordering code).

The node can be easily installed also on solenoid valves manifold already mounted on equipment.

Module can manage up to 32 solenoid valves, and, in the same time, a max number of 4 Input modules 5225.08T or a max number of 4 Input modules 5225.12T.

The EtherCAT® module, regardless the number of Input module connected, reports to have connected 4 Input modules.

Regardless of the number of Input modules connected, the manageable solenoid valves are 32.

Node power supply is made by a M12 4P male circular connector.

The separation between node 24 VDC Power supply and outputs 24 VDC allows to switch off the outputs maintaining powered the node and inputs, if present.

Connection to Bus EtherCAT® is possible via 2 M12 4P type D female circular connectors. These two connectors lead the signal to two different communication ports, so they are not connected in parallel.

The node address is assigned during configuration.

**Note: 5700 series has a different configuration file from series 5600.**

**Ordering code**

**5725.32T.EC**

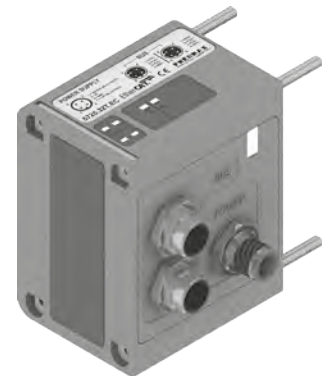

**Scheme / Overall dimensions and I/O layout :**

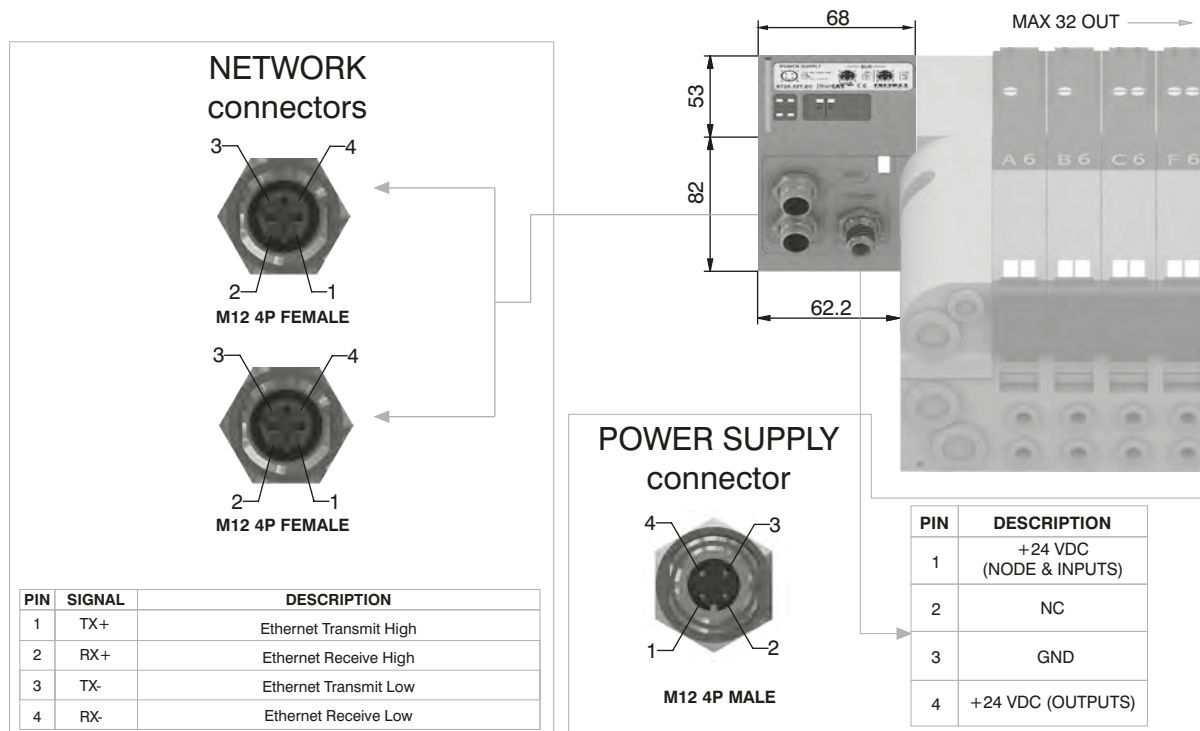

**Technical characteristics**

Model	5725.32T.EC	
Specifications	EtherCAT® Specifications ETG.1000 series	
Case	Reinforced technopolymer	
<b>Power supply</b>	Power supply connection	M12 4P male connector (IEC 60947-5-2)
	Power supply voltage	+24 VDC +/- 10%
	Node consumption (without inputs)	400 mA
	Power supply diagnosis	Green LEDPWR / Green LED OUT
<b>Outputs</b>	PNP equivalent outputs	+24 VDC +/- 10%
	Maximum current for each output	100 mA
	Maximum output number	32
	Max output simultaneously actuated	32
<b>Network</b>	Network connectors	2 M12 4P female connectors Type D (IEC 61076-2-101)
	Baud rate	100 Mbit/s
	Addresses, possible numbers	From 1 to 65535
	Max nodes in net	65536 (Master + Slave)
	Maximum distance between 2 nodes	100 m
	Bus diagnosis	1 green and 1 red LED for status + 2 LEDs for link & activity
	Configuration file	Available from our web site: <a href="http://www.pneumaxspa.com">http://www.pneumaxspa.com</a>
	IP protection grade	IP65 when assembled
	Temperature range	From 0° to +50° C





**General :**

PROFINET IO RT module is directly integrated on Optyima-T solenoid valves manifold via a 37 poles connector, normally used for multipolar cable connection.  
Optyima-T solenoid valves connected to node must be PNP equivalent (final 02 in ordering code).

The node can be easily installed also on solenoid valves manifold already mounted on equipment.

Module can manage up to 32 solenoid valves, and, in the same time, a max number of 8 Input modules 5225.08T or a max number of 8 Input modules 5225.12T.

The PROFINET IO RT module, regardless the number of Input module connected, reports to have connected 8 Input modules.

Regardless of the number of Input modules connected, the manageable solenoid valves are 32.

Node power supply is made by a M12 4P male circular connector.

The separation between node 24 VDC Power supply and outputs 24 VDC allows to switch off the outputs maintaining powered the node and inputs, if present.

Connection to Bus PROFINET IO RT is possible via 2 M12 4P type D female circular connectors. These two connectors lead the signal to two different communication ports, so they are not connected in parallel.

The node address is assigned during configuration.

**Ordering code**

**5725.32T.PN**



1  
AIR DISTRIBUTION

**Scheme / Overall dimensions and I/O layout :**

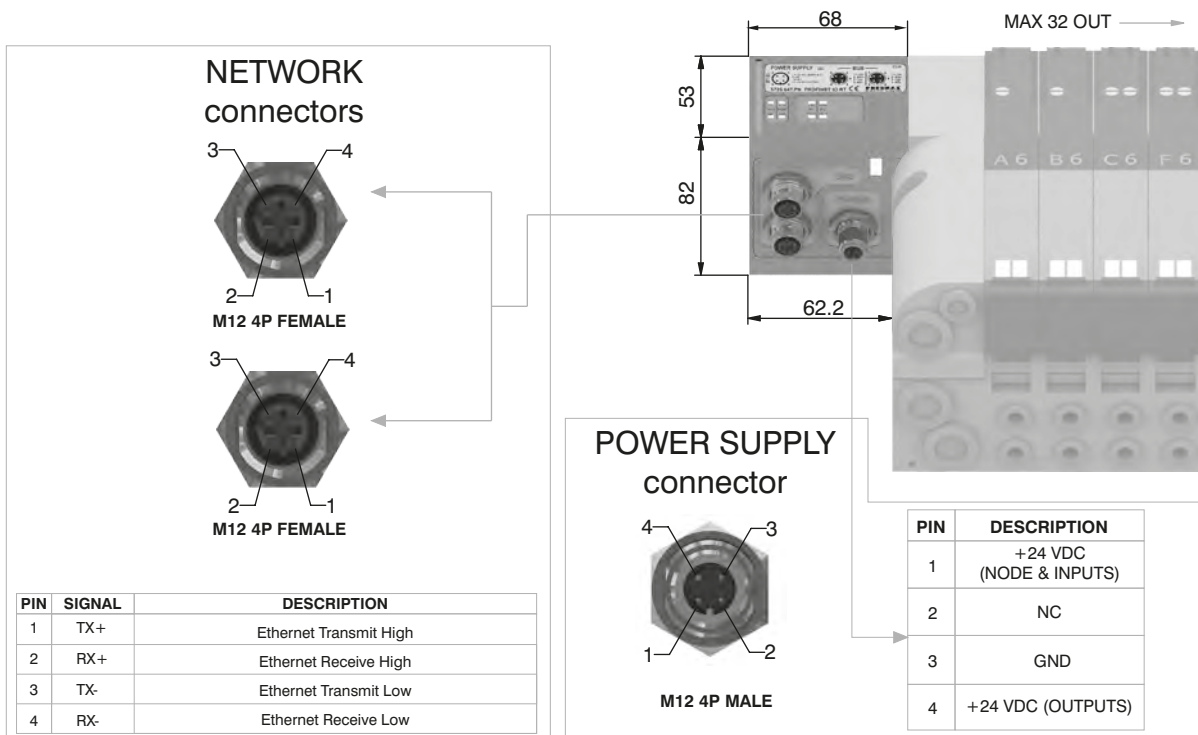

PIN	SIGNAL	DESCRIPTION
1	TX+	Ethernet Transmit High
2	RX+	Ethernet Receive High
3	TX-	Ethernet Transmit Low
4	RX-	Ethernet Receive Low

PIN	DESCRIPTION
1	+24 VDC (NODE & INPUTS)
2	NC
3	GND
4	+24 VDC (OUTPUTS)

**Technical characteristics**

	Model	5725.32T.PN
	Specifications	PROFINET IO RT
	Case	Reinforced technopolymer
<b>Power supply</b>	Power supply connection	M12 4P male connector (IEC 60947-5-2)
	Power supply voltage	+24 VDC +/- 10%
	Node consumption (without inputs)	400 mA
	Power supply diagnosis	Green LED PWR / Green LED OUT
<b>Outputs</b>	PNP equivalent outputs	+24 VDC +/- 10%
	Maximum current for each output	100 mA
	Maximum output number	32
	Max output simultaneously actuated	32
<b>Network</b>	Network connectors	2 M12 4P female connectors Type D (IEC 61076-2-101)
	Baud rate	100 Mbit/s
	Addresses, possible numbers	As an IP address
	Max nodes in net	As an Ethernet Network
	Maximum distance between 2 nodes	100 m
	Bus diagnosis	1 green and 1 red LED for status + 4 LEDs for link & activity
	Configuration file	Available from our web site: <a href="http://www.pneumaxspa.com">http://www.pneumaxspa.com</a>
	IP protection grade	IP65 when assembled
	Temperature range	From 0° to +50° C

**General :**

EtherNet/IP module is directly integrated on Optyma-T solenoid valves manifold via a 37 poles connector, normally used for multipolar cable connection. Optyma-T solenoid valves connected to node must be PNP equivalent (final 02 in ordering code).

The node can be easily installed also on solenoid valves manifold already mounted on equipment.

Module can manage up to 32 solenoid valves, and, in the same time, a max number of 8 Input modules 5225.08T or a max number of 8 Input modules 5225.12T.

The EtherNet/IP module, regardless the number of Input module connected, reports to have connected 8 Input modules.

Regardless of the number of Input modules connected, the managable solenoid valves are 32.

Node power supply is made by a M12 4P male circular connector.

The separation between node 24 VDC Power supply and outputs 24 VDC allows to switch off the outputs mantaning powered the node and inputs, if present.

Connection to Bus EtherNet/IP is possible via 2 M12 4P type D female circular connectors. These two connectors lead the signal to two different communication ports, so they are not connected in parallel.

The node address is assigned during configuration.

**Ordering code**

**5725.32T.EI**

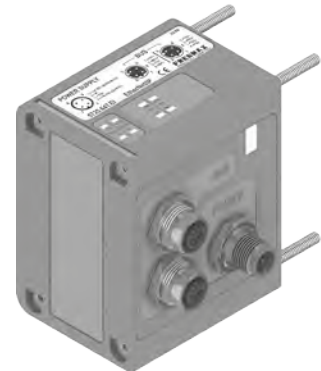

**Scheme / Overall dimensions and I/O layout :**

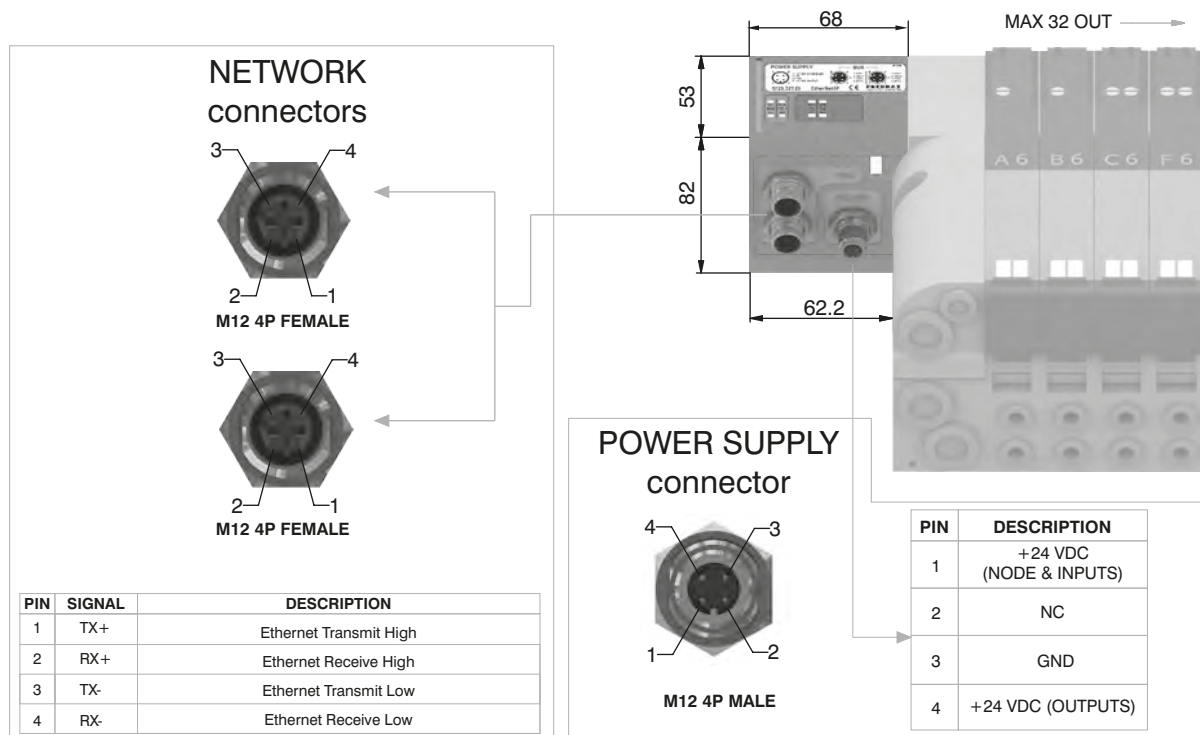

**Technical characteristics**

Model	5725.32T.EI
Specifications	The EtherNet/IP Specification
Case	Reinforced technopolymer
<b>Power supply</b>	Power supply connection M12 4P male connector (IEC 60947-5-2)
	Power supply voltage +24 VDC +/- 10%
	Node consumption (without inputs) 400 mA
	Power supply diagnosis Green LED PWR / Green LED OUT
<b>Outputs</b>	PNP equivalent outputs +24 VDC +/- 10%
	Maximum current for each output 100 mA
	Maximum output number 32
	Max output simultaneously actuated 32
<b>Network</b>	Network connectors 2 M12 4P female connectors Type D (IEC 61076-2-101)
	Baud rate 100 Mbit/s
	Addresses, possible numbers As an IP address
	Max nodes in net As an Ethernet Network
	Maximum distance between 2 nodes 100 m
	Bus diagnosis 1 green and 1 red LED for status + 4 LEDs for link & activity
	Configuration file Available from our web site: <a href="http://www.pneumaxspa.com">http://www.pneumaxspa.com</a>
	IP protection grade IP65 when assembled
	Temperature range From 0° to +50° C



**General :**

Powerlink module is directly integrated on Optyima-T solenoid valves manifold via a 37 poles connector, normally used for multipolar cable connection.  
Optyima-T solenoid valves connected to node must be PNP equivalent (final 02 in ordering code).

The node can be easily installed also on solenoid valves manifold already mounted on equipment.

Module can manage up to 32 solenoid valves, and, in the same time, a max number of 8 Input modules 5225.08T or a max number of 8 Input modules 5225.12T.

The Powerlink module, regardless the number of Input module connected, reports to have connected 8 Input modules.

Regardless of the number of Input modules connected, the manageable solenoid valves are 32.

Node power supply is made by a M12 4P male circular connector.

The separation between node 24 VDC Power supply and outputs 24 VDC allows to switch off the outputs maintaining powered the node and inputs, if present.

Connection to Bus Powerlink is possible via 2 M12 4P type D female circular connectors. These two connectors lead the signal to two different communication ports, so they are not connected in parallel.

The node address is assigned during configuration.

**Ordering code**

**5725.32T.PL**

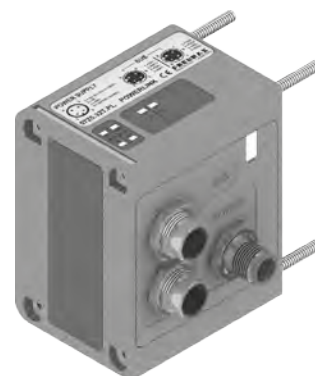

1  
AIR DISTRIBUTION

**Scheme / Overall dimensions and I/O layout :**

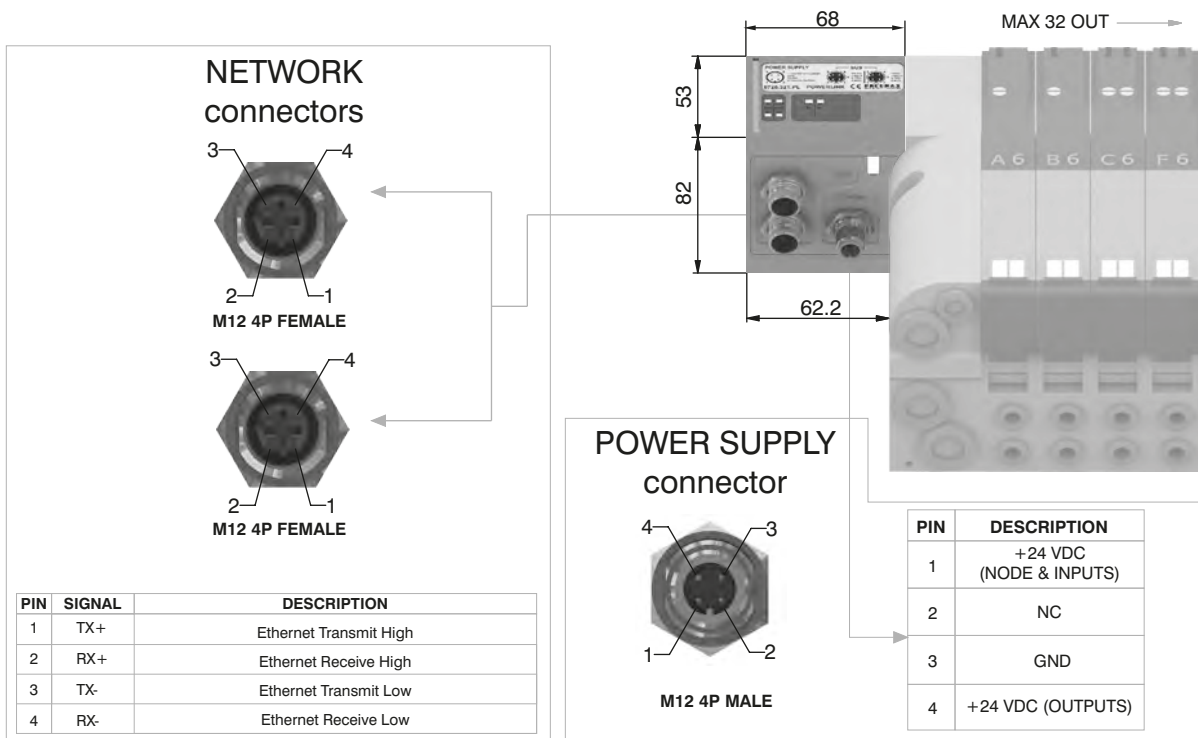

**Technical characteristics**

Model	5725.32T.PL	
Specifications	Ethernet POWERLINK Communication Profile Specifications	
Case	Reinforced technopolymer	
<b>Power supply</b>	Power supply connection	M12 4P male connector (IEC 60947-5-2)
	Power supply voltage	+24 VDC +/- 10%
	Node consumption (without inputs)	400 mA
	Power supply diagnosis	Green LED PWR / Green LED OUT
<b>Outputs</b>	PNP equivalent outputs	+24 VDC +/- 10%
	Maximum current for each output	100 mA
	Maximum output number	32
	Max output simultaneously actuated	32
<b>Network</b>	Network connectors	2 M12 4P female connectors Type D (IEC 61076-2-101)
	Baud rate	100 Mbit/s
	Addresses, possible numbers	239
	Max nodes in net	240
	Maximum distance between 2 nodes	100 m
	Bus diagnosis	1 green and 1 red LED for status + 2 LEDs for link & activity
	Configuration file	Available from our web site: <a href="http://www.pneumaxspa.com">http://www.pneumaxspa.com</a>
	IP protection grade	IP65 when assembled
Temperature range	From 0° to +50° C	

**General :**

Modbus/TCP module is directly integrated on Optyma-T solenoid valves manifold via a 37 poles connector, normally used for multipolar cable connection.  
 Optyma-T solenoid valves connected to node must be PNP equivalent (final 02 in ordering code).

The node can be easily installed also on solenoid valves manifold already mounted on equipment.

Module can manage up to 32 solenoid valves, and, in the same time, a max number of 8 Input modules 5225.08T or a max number of 8 Input modules 5225.12T.

The Modbus/TCP module, regardless the number of Input module connected, reports to have connected 8 Input modules.

Regardless of the number of Input modules connected, the manageable solenoid valves are 32.

Node power supply is made by a M12 4P male circular connector.

The separation between node 24 VDC Power supply and outputs 24 VDC allows to switch off the outputs maintaining powered the node and inputs, if present.

Connection to Bus Modbus/TCP is possible via 2 M12 4P type D female circular connectors. These two connectors lead the signal to two different communication ports, so they are not connected in parallel.

The node address is assigned during configuration.

**Ordering code**

**5725.32T.MT**



**Scheme / Overall dimensions and I/O layout :**

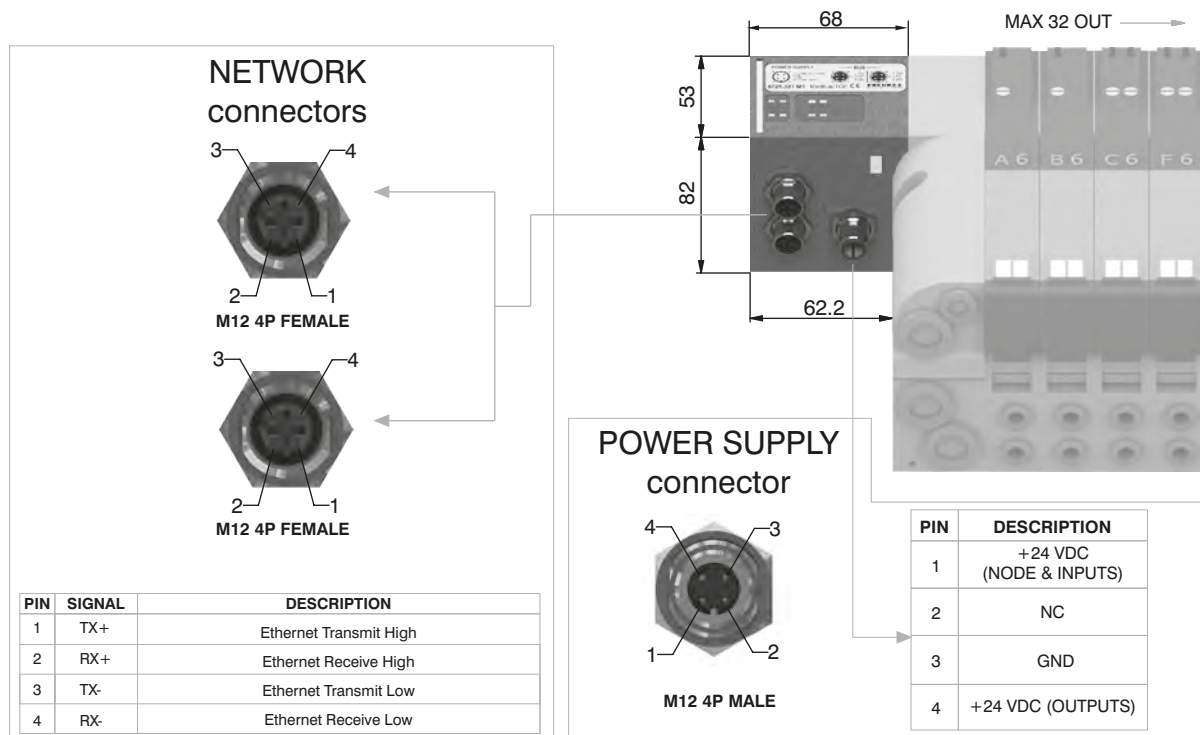

**Technical characteristics**

Model	5725.32T.MT
Specifications	MODBUS Application Protocol Specification V1.1a, June 4, 2004
Case	Reinforced technopolymer
<b>Power supply</b>	Power supply connection M12 4P male connector (IEC 60947-5-2)
	Power supply voltage +24 VDC +/- 10%
	Node consumption (without inputs) 400 mA
	Power supply diagnosis Green LED PWR / Green LED OUT
<b>Outputs</b>	PNP equivalent outputs +24 VDC +/- 10%
	Maximum current for each output 100 mA
	Maximum output number 32
	Max output simultaneously actuated 32
<b>Network</b>	Network connectors 2 M12 4P female connectors Type D (IEC 61076-2-101)
	Baud rate 100 Mbit/s
	Addresses, possible numbers 248
	Max nodes in net 248
	Maximum distance between 2 nodes 100 m
	Bus diagnosis 1 green and 1 red LED for status + 2 LEDs for link & activity
	Configuration file Modbus/TCP nodes don't require configuration file
	IP protection grade IP65 when assembled
	Temperature range From 0° to +50° C



**General :**

Modules have 8 connectors M8 3P female.

The Inputs are PNP equivalent 24 VDC ±10%.

To each connector it is possible to plug both 2 wires Inputs (switches, magnetic switches pressure switches, etc) or 3 wires Inputs (proximity, photocells, electronic sensors, etc).

The maximum current available for all 8 Inputs is 300 mA.

Each module includes a 300 mA self-mending fuse. If a short circuit or a overcharge (overall current >300mA) occur the safety device acts cutting the 24 VDC power supply to all M8 connectors on the module and switching off the green led PWR. Any other Input module connected to the node will remain powered and will function correctly.

Once the cause of the fault disappears the green LED PWR lights up indicating the ON state and the node will re-start to operate.

The maximum number of Input modules supported is 4 for CANopen®, DeviceNet and EtherCAT®.

The maximum number of Input modules supported is 8 for PROFIBUS DP, PROFINET IO RT EtherNet/IP and Powerlink.

**Ordering code**

5225.08T



**Scheme / Overall dimensions and I/O layout :**

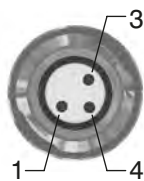
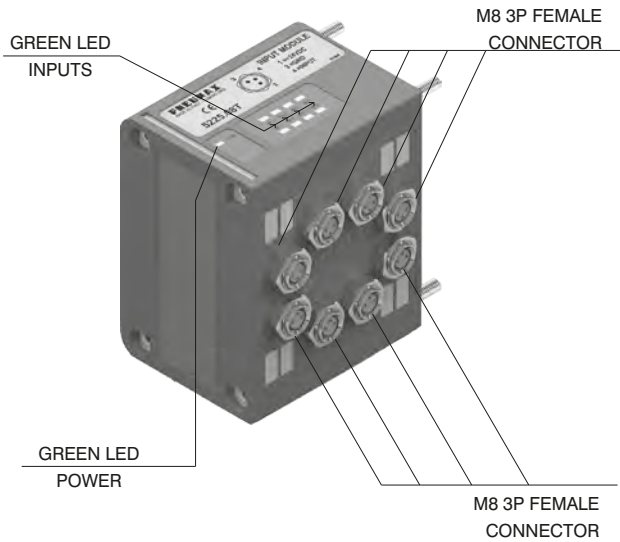

PIN	DESCRIPTION
1	+24 VDC
4	INPUT
3	GND

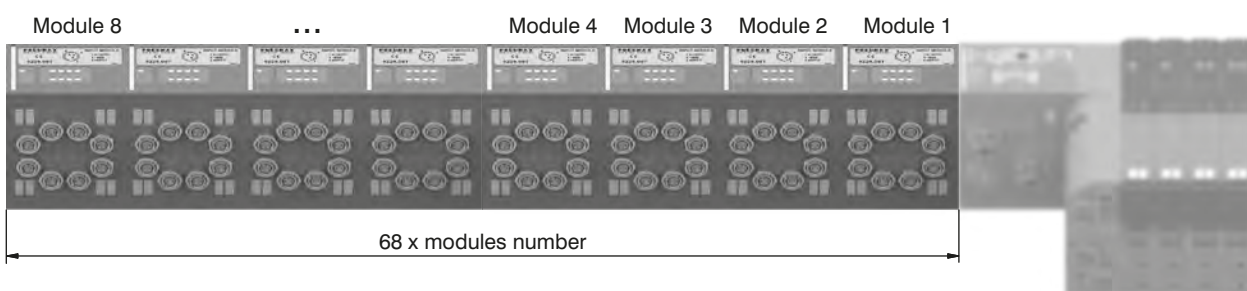
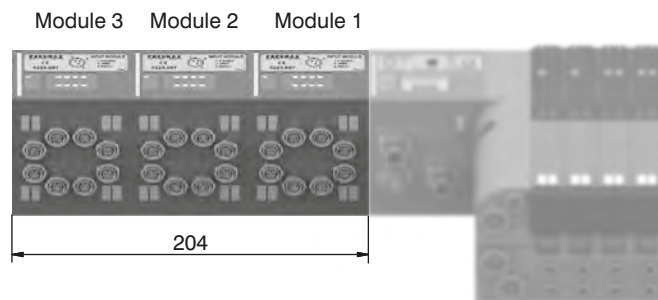
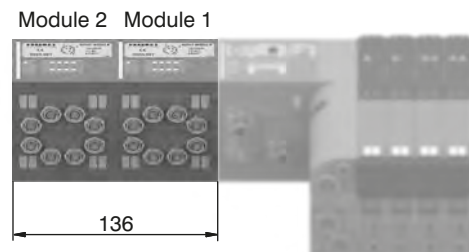
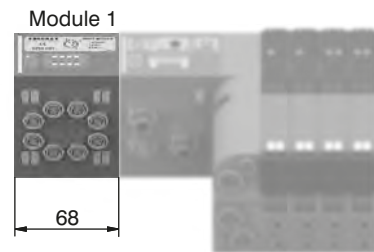

1  
AIR DISTRIBUTION

**General :**

Modules have 4 connectors M12 5P female.

The Inputs are PNP equivalent 24 VDC ±10%.

To each connector it is possible to plug both 2 wires Inputs (switches, magnetic switches pressure switches, etc) or 3 wires Inputs (proximity, photocells, electronic sensors, etc).

The maximum current available for all 8 Inputs is 300 mA.

Each module includes a 300 mA self-mending fuse. If a short circuit or a overcharge (overall current >300mA) occur the safety device acts cutting the 24 VDC power supply to all M8 connectors on the module and switching off the green led PWR. Any other Input module connected to the node will remain powered and will function correctly.

Once the cause of the fault disappears the green LED PWR lights up indicating the ON state and the node will re-start to operate.

The maximum number of Input modules supported is 4 for CANopen®, DeviceNet and EtherCAT®.

The maximum number of Input modules supported is 8 for PROFIBUS DP, PROFINET IO RT EtherNet/IP and Powerlink.

**Ordering code**

**5225.12T**



**Scheme / Overall dimensions and I/O layout :**

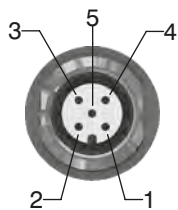
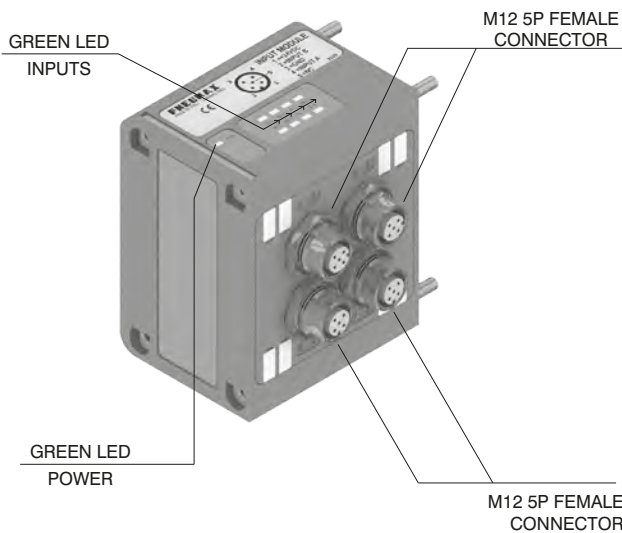

PIN	DESCRIPTION
1	+24 VDC
2	INPUT B
3	GND
4	INPUT A
5	NC

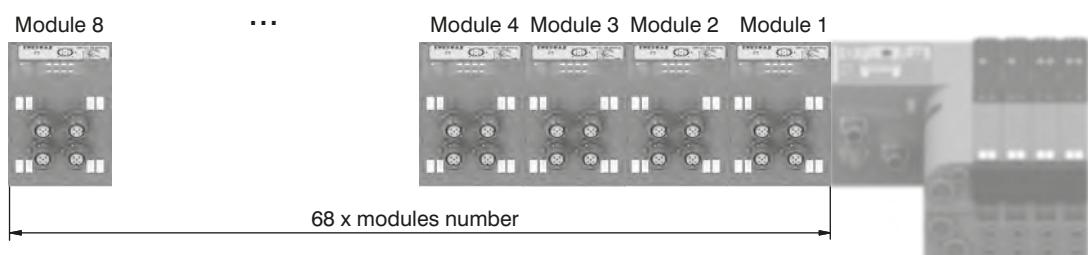
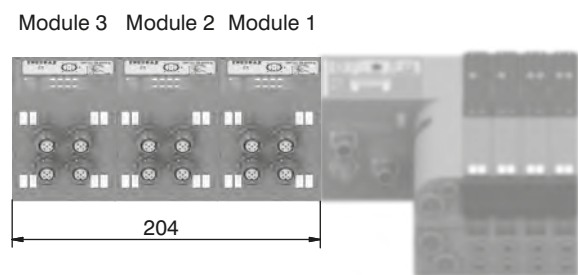
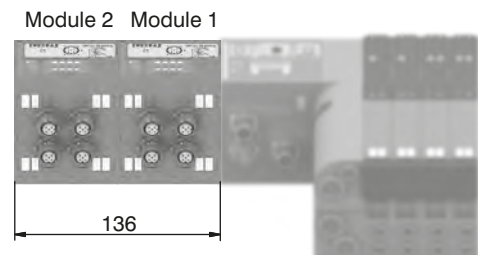
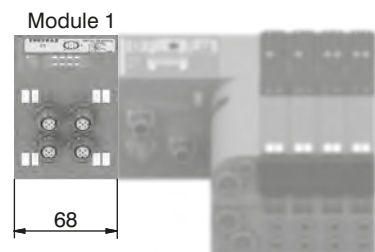



**General :**

This module is fitted with two M8 3 pin female connectors.

With this module is possible to read two analogue inputs (voltage or current).

The inputs are sampled at 12 bit.

For practicality the sampled value is transmitted with 16 bit, of which the four less significant are fixed at zero.

Available models:

- 5225.2T.00T (voltage signal 0 - 10V);
- 5225.2T.01T (voltage signal 0 - 5V);
- 5225.2C.00T (current signal 4 - 20mA);
- 5225.2C.01T (current signal 0 - 20mA).

Each module includes a 300 mA self-mending fuse. Should a short circuit or a overcharge (overall current >300mA) occur the safety device intervenes cutting the 24VDC power supply to all M8 connectors on the module and switching off the green LED PWR. Any other Input module connected to the node will remain powered and will function correctly. Once the cause of the fault is removed the green LED lights up indicating the ON state and the node will re-start to operate.

This module is counted as four 8 digital Inputs modules.

The Maximum number of 2 analogue Inputs modules supported is 1 for CANopen®, DeviceNet®, PROFIBUS DP and EtherCAT®.

The Maximum number of 2 analogue Inputs modules supported is 2 for PROFINET IO RT, EtherNet/IP and Powerlink.

**Ordering code**

5225.2 \_ . \_ T



1  
AIR DISTRIBUTION

**Scheme / Overall dimensions and I/O layout :**

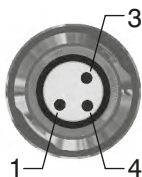
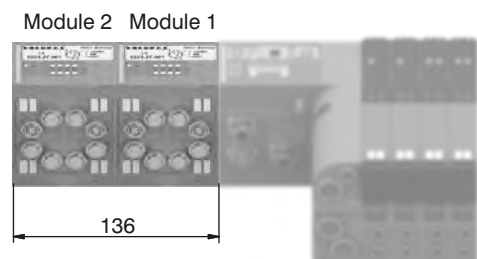
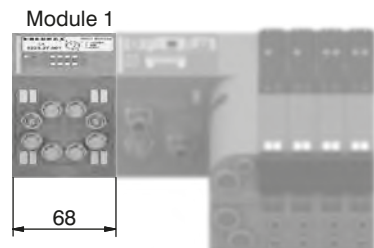
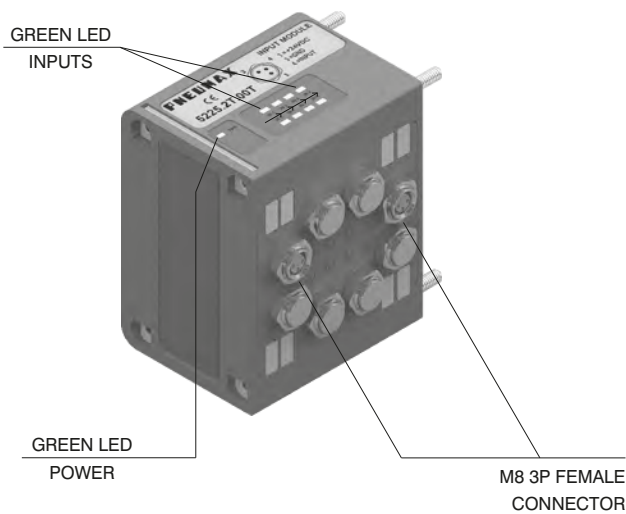

PIN	DESCRIPTION
1	+24 VDC
4	INPUT
3	GND

**General :**

This module is fitted with two M8 3 pin female connectors.  
 With this module is possible to read two Pt100 probes.  
 The inputs are sampled at 12 bit.  
 For practicality the sampled value is transmitted with 16 bit, of which the four less significant are fixed at zero.  
 It is possible to plug 3-wires probes or 2-wires probes.  
 The temperature is expressed in tenths of degree.  
 The temperature range is 0 – 250°C, beyond which the green LED for probe presence doesn't light on.  
 The module returns a value correspondent to 250°C when the probe is not connected.

Available models:  
 5225.2P00T (2-wires probes);  
 5225.2P01T (3-wires probes).

Each module includes a 300 mA self-mending fuse. Should a short circuit or a overcharge (overall current >300mA) occur the safety device intervenes cutting the 24VDC power supply to all M8 connectors on the module and switching off the green LED PWR. Any other Input module connected to the node will remain powered and will function correctly.  
 Once the cause of the fault is removed the green LED lights up indicating the ON state and the node will re-start to operate.  
 This module is counted as four 8 digital Inputs modules.

The Maximum number of 2 Pt100 Inputs modules supported is 1 for CANopen®, DeviceNet, PROFIBUS DP and EtherCAT®.  
 The Maximum number of 2 Pt100 Inputs modules supported is 2 for PROFINET IO RT, EtherNet/IP and Powerlink.

**Ordering code**

**5225.2P . 0\_T**



**Scheme / Overall dimensions and I/O layout :**

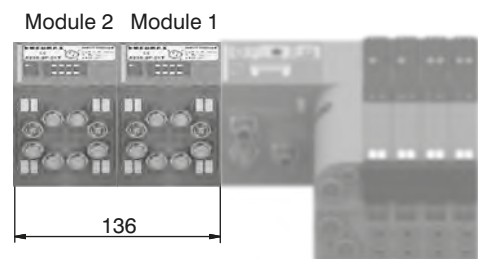
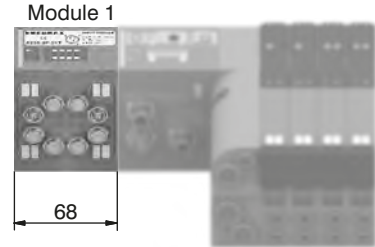
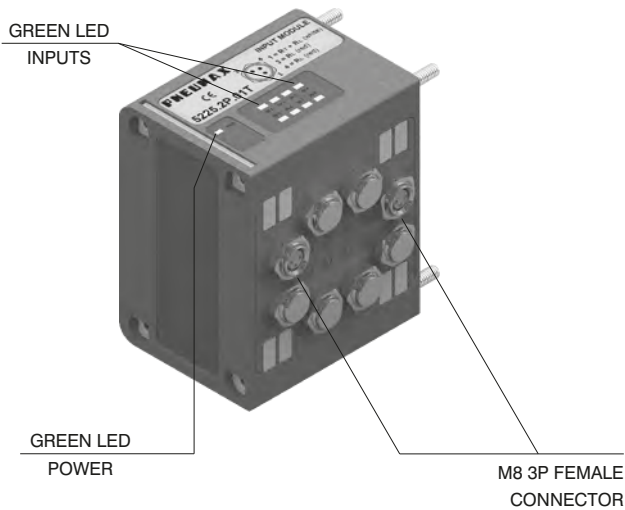

**3 WIRES**

PIN	DESCRIPTION
1	RT (white)
4	RL (red)
3	RL (red)

**2 WIRES**

PIN	DESCRIPTION
1	RT (white)
4	NC
3	RL (red)





**General :**

This module is fitted with two M8 3 pin female connectors.

With this module is possible to read two Pt100 probes.

The inputs are sampled at 12 bit.

For practicality the sampled value is transmitted with 16 bit, of which the four less significant are fixed at zero.

It is possible to plug 3-wires probes or 2-wires probes.

The temperature is expressed in points according to the formula

$$\text{Temperature} = \left( \frac{\text{Points}}{4095} \times 600 \right) - 200$$

The temperature range is -200 to +400°C, beyond which the green LED for probe presence doesn't light on.

The module returns a value correspondent to 400°C when the probe is not connected.

Available models:

5225.2P.10T (2-wires probes);

5225.2P.11T (3-wires probes).

Each module includes a 300 mA self-mending fuse. Should a short circuit or a overcharge (overall current >300mA) occur the safety device intervenes cutting the 24VDC power supply to all M8 connectors on the module and switching off the green LED PWR. Any other INPUT module connected to the node will remain powered and will function correctly.

Once the cause of the fault is removed the green LED lights up indicating the ON state and the node will re-start to operate.

This module is counted as four 8 digital Inputs modules.

The Maximum number of 2 Pt100 Inputs modules supported is 1 for CANopen®, DeviceNet, PROFIBUS DP and EtherCAT®.

The Maximum number of 2 Pt100 Inputs modules supported is 2 for PROFINET IO RT, EtherNet/IP and Powerlink.

**Ordering code**

5225.2P . 1\_T



1  
AIR DISTRIBUTION

**Scheme / Overall dimensions and I/O layout :**

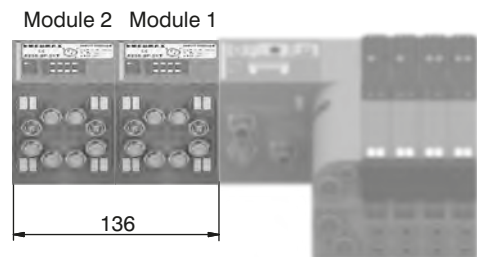
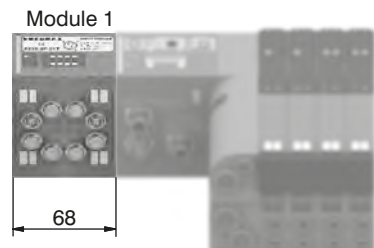
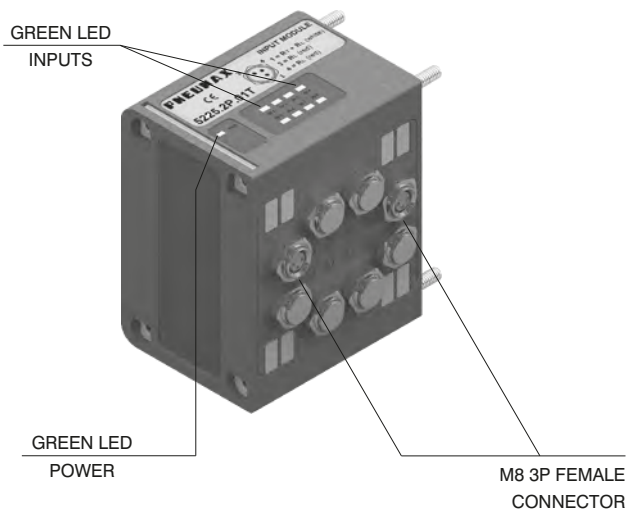

**3 WIRES**

PIN	DESCRIPTION
1	RT (white)
4	RL (red)
3	RL (red)

**2 WIRES**

PIN	DESCRIPTION
1	RT (white)
4	NC
3	RL (red)

Socket for Power Supply  
STRAIGHT CONNECTOR  
M12A 4P FEMALE

Ordering code

5312A.F04.00



POWER SUPPLY connector

Upper view  
Slave connector

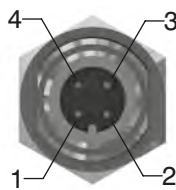

PIN	DESCRIPTION
1	+24 VDC Node
2	
3	0 V
4	+24 VDC Outputs

Socket for Bus CANopen®/DeviceNet  
STRAIGHT CONNECTOR  
M12A 5P FEMALE

Ordering code

5312A.F05.00

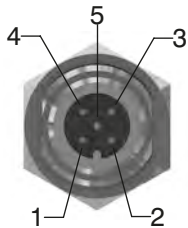

PIN	DESCRIPTION
1	(CAN_SHIELD)
2	(CAN_V+)
3	CAN_GND
4	CAN_H
5	CAN_L

Upper view  
Slave connector

NETWORK connectors

Plug for Bus CANopen®/DeviceNet  
STRAIGHT CONNECTOR  
M12A 5P MALE

Ordering code

5312A.M05.00

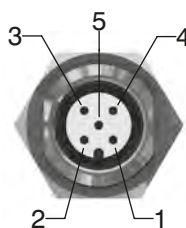

Plug for Bus EtherCAT®,  
PROFINET IO RT,  
EtherNet/IP and Powerlink  
STRAIGHT CONNECTOR M12D 4P MALE

Ordering code

5312D.M04.00



PIN	SIGNAL	DESCRIPTION
1	TX+	Ethernet Transmit High
2	RX+	Ethernet Receive High
3	TX-	Ethernet Transmit Low
4	RX-	Ethernet Receive Low

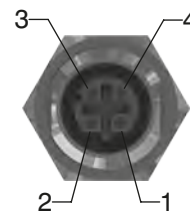

Upper view  
Slave connector

Socket for Bus PROFIBUS DP  
STRAIGHT CONNECTOR  
M12B 5P FEMALE

Ordering code

5312B.F05.00

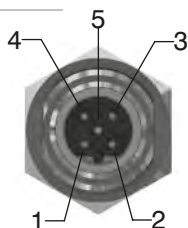

PIN	DESCRIPTION
1	Power Supply
2	A-line
3	DGND
4	B-line
5	SHIELD

Upper view  
Slave connector

Plug for Bus PROFIBUS DP  
STRAIGHT CONNECTOR  
M12B 5P MALE

Ordering code

5312B.M05.00

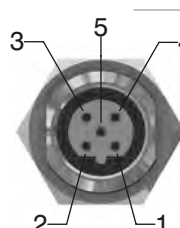

Plug for Input module  
STRAIGHT CONNECTOR  
M8 3P MALE

Ordering code

5308A.M03.00



INPUT connectors

Upper view  
Slave connector

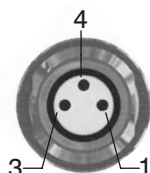

PIN	DESCRIPTION
1	+24 VDC
4	INPUT
3	GND

Plug for Input module  
STRAIGHT CONNECTOR  
M12A 5P MALE

Ordering code

5312A.M05.00



M12 plug

Ordering code

5300.T12



Plugs

M8 plug

Ordering code

5300.T08

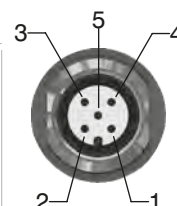

PIN	DESCRIPTION
1	+24 VDC
2	INPUT B
3	GND
4	INPUT A
5	NC

Trademarks: EtherCAT® is registered trademark and patented technology, licensed by Beckhoff Automation GmbH, Germany.



Manifold Layout configuration

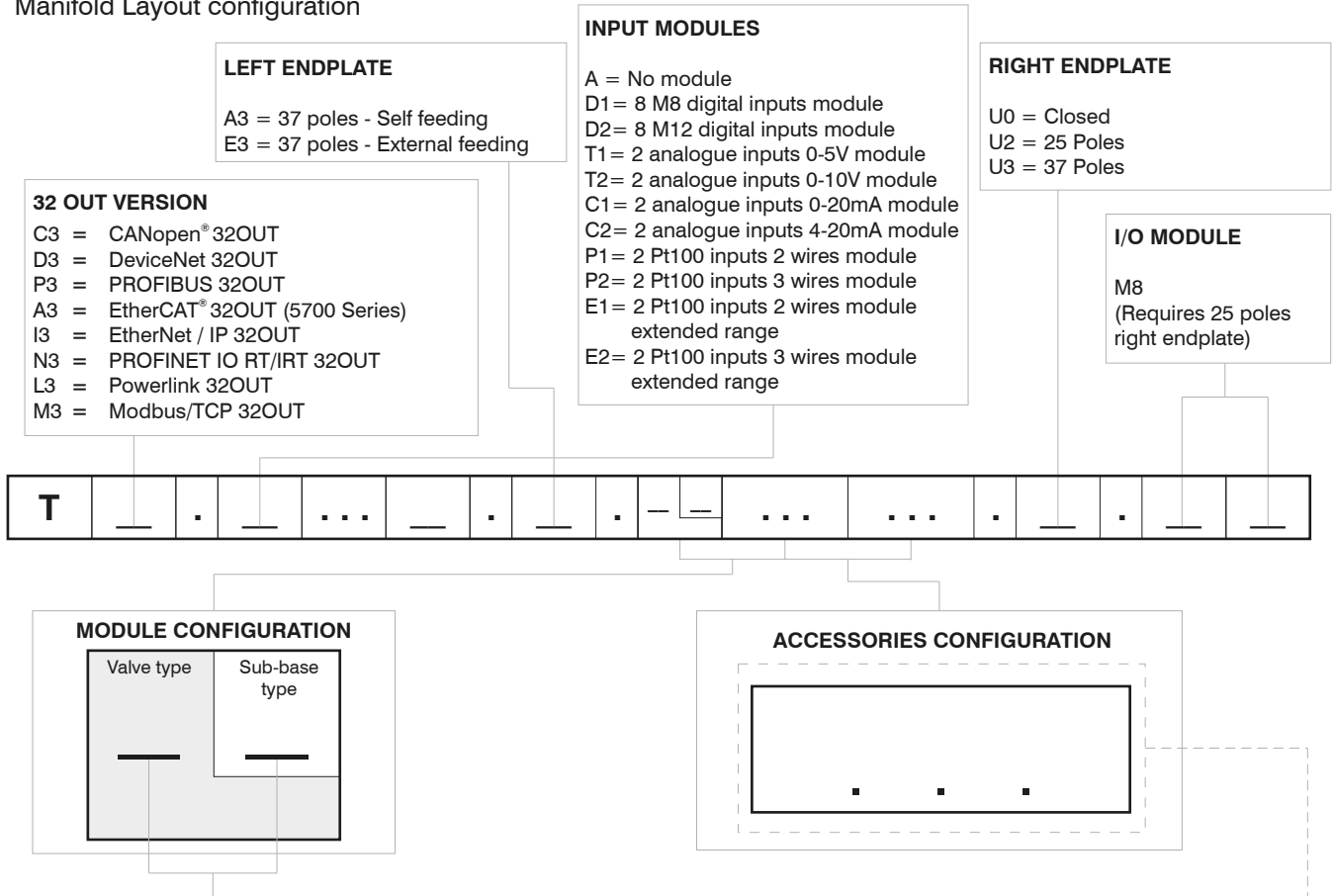

SHORT CODE FUNCTION / CONNECTION :

- A1= 5/2 Sol.-Spring + BASE 1 - CARTR. G1/8" GAS
- A2= 5/2 Sol.-Spring + BASE 2 - CARTR. G1/8" GAS
- A3= 5/2 Sol.-Spring + BASE 1 - CARTR. 04
- A4= 5/2 Sol.-Spring + BASE 2 - CARTR. 04
- A5= 5/2 Sol.-Spring + BASE 1 - CARTR. 06
- A6= 5/2 Sol.-Spring + BASE 2 - CARTR. 06
- A7= 5/2 Sol.-Spring + BASE 1 - CARTR. 08
- A8= 5/2 Sol.-Spring + BASE 2 - CARTR. 08
- B1= 5/2 Sol.-Diff. + BASE 1 - CARTR. G1/8" GAS
- B2= 5/2 Sol.-Diff. + BASE 2 - CARTR. G1/8" GAS
- B3= 5/2 Sol.-Diff. + BASE 1 - CARTR. 04
- B4= 5/2 Sol.-Diff. + BASE 2 - CARTR. 04
- B5= 5/2 Sol.-Diff. + BASE 1 - CARTR. 06
- B6= 5/2 Sol.-Diff. + BASE 2 - CARTR. 06
- B7= 5/2 Sol.-Diff. + BASE 1 - CARTR. 08
- B8= 5/2 Sol.-Diff. + BASE 2 - CARTR. 08
- C2= 5/2 Sol.-Sol. + BASE 2 - CARTR. G1/8" GAS
- C4= 5/2 Sol.-Sol. + BASE 2 - CARTR. 04
- C6= 5/2 Sol.-Sol. + BASE 2 - CARTR. 06
- C8= 5/2 Sol.-Sol. + BASE 2 - CARTR. 08
- E2= 5/3 CC Sol.-Sol. + BASE 2 - CARTR. G1/8" GAS
- E4= 5/3 CC Sol.-Sol. + BASE 2 - CARTR. 04
- E6= 5/3 CC Sol.-Sol. + BASE 2 - CARTR. 06
- E8= 5/3 CC Sol.-Sol. + BASE 2 - CARTR. 08
- F2= 2x3/2 NC-NC (= 5/3 OC) Sol.-Sol. + BASE 2 - CARTR. G1/8" GAS
- F4= 2x3/2 NC-NC (= 5/3 OC) Sol.-Sol. + BASE 2 - CARTR. 04
- F6= 2x3/2 NC-NC (= 5/3 OC) Sol.-Sol. + BASE 2 - CARTR. 06
- F8= 2x3/2 NC-NC (= 5/3 OC) Sol.-Sol. + BASE 2 - CARTR. 08
- G2= 2x3/2 NO-NO (= 5/3 PC) Sol.-Sol. + BASE 2 - CARTR. G1/8" GAS
- G4= 2x3/2 NO-NO (= 5/3 PC) Sol.-Sol. + BASE 2 - CARTR. 04
- G6= 2x3/2 NO-NO (= 5/3 PC) Sol.-Sol. + BASE 2 - CARTR. 06
- G8= 2x3/2 NO-NO (= 5/3 PC) Sol.-Sol. + BASE 2 - CARTR. 08
- H2= 2x3/2 NC-NO Sol.-Sol. + BASE 2 - CARTR. G1/8" GAS
- H4= 2x3/2 NC-NO Sol.-Sol. + BASE 2 - CARTR. 04
- H6= 2x3/2 NC-NO Sol.-Sol. + BASE 2 - CARTR. 06
- H8= 2x3/2 NC-NO Sol.-Sol. + BASE 2 - CARTR. 08
- I2= 2x3/2 NO-NC Sol.-Sol. + BASE 2 - CARTR. G1/8" GAS
- I4= 2x3/2 NO-NC Sol.-Sol. + BASE 2 - CARTR. 04
- I6= 2x3/2 NO-NC Sol.-Sol. + BASE 2 - CARTR. 06
- I8= 2x3/2 NO-NC Sol.-Sol. + BASE 2 - CARTR. 08
- T1= Free valve space plug + BASE 1 - CARTR. G1/8" GAS
- T2= Free valve space plug + BASE 2 - CARTR. G1/8" GAS
- T3= Free valve space plug + BASE 1 - CARTR. 04
- T4= Free valve space plug + BASE 2 - CARTR. 04
- T5= Free valve space plug + BASE 1 - CARTR. 06
- T6= Free valve space plug + BASE 2 - CARTR. 06
- T7= Free valve space plug + BASE 1 - CARTR. 08
- T8= Free valve space plug + BASE 2 - CARTR. 08

ACCESSORIES

- U2 = Electric and electro-pneumatic cut off module 2 positions
- K2 = Electric and electro-pneumatic cut off module 2 positions with external pilot
- U4 = Electric and electro-pneumatic cut off module 4 positions
- K4 = Electric and electro-pneumatic cut off module 4 positions with external pilot
- U6 = Electric and electro-pneumatic cut off module 6 positions
- K6 = Electric and electro-pneumatic cut off module 6 positions with external pilot
- U8 = Electric and electro-pneumatic cut off module 8 positions
- K8 = Electric and electro-pneumatic cut off module 8 positions with external pilot
- W = Intermediate supply & exhaust module
- X = Diaphragm plug on pipe 1
- Y = Diaphragm plug on pipe 33
- Z = Diaphragm plug on pipe 5
- XY = Diaphragm plug on pipe 1 & 3
- ZX = Diaphragm plug on pipe 5 & 1
- ZY = Diaphragm plug on pipe 5 & 3
- ZXY = Diaphragm plug on pipe 5, 1 & 3

While configuring the manifold always be careful that the maximum number of electrical signals available is 32. The use of monostable valve mounted on a base type 2 ( 2 electrical signals occupied ) causes the loss of one electric signal. In this case the monostable valve can be replaced by a bistable valve. The diaphragms plugs are used to intercept the conduits 1,3 & 5 of the base. If it is necessary to interrupt more than one conduit in the same time then put in line the letters which identifies the position (for example : regarding the 3 & 5 conduits, put the Y & Z letters). Should one or more conduits be cut more than one time it is necessary to add the relevant intermediate Supply/Exhaust module.

1 AIR DISTRIBUTION



AIR DISTRIBUTION

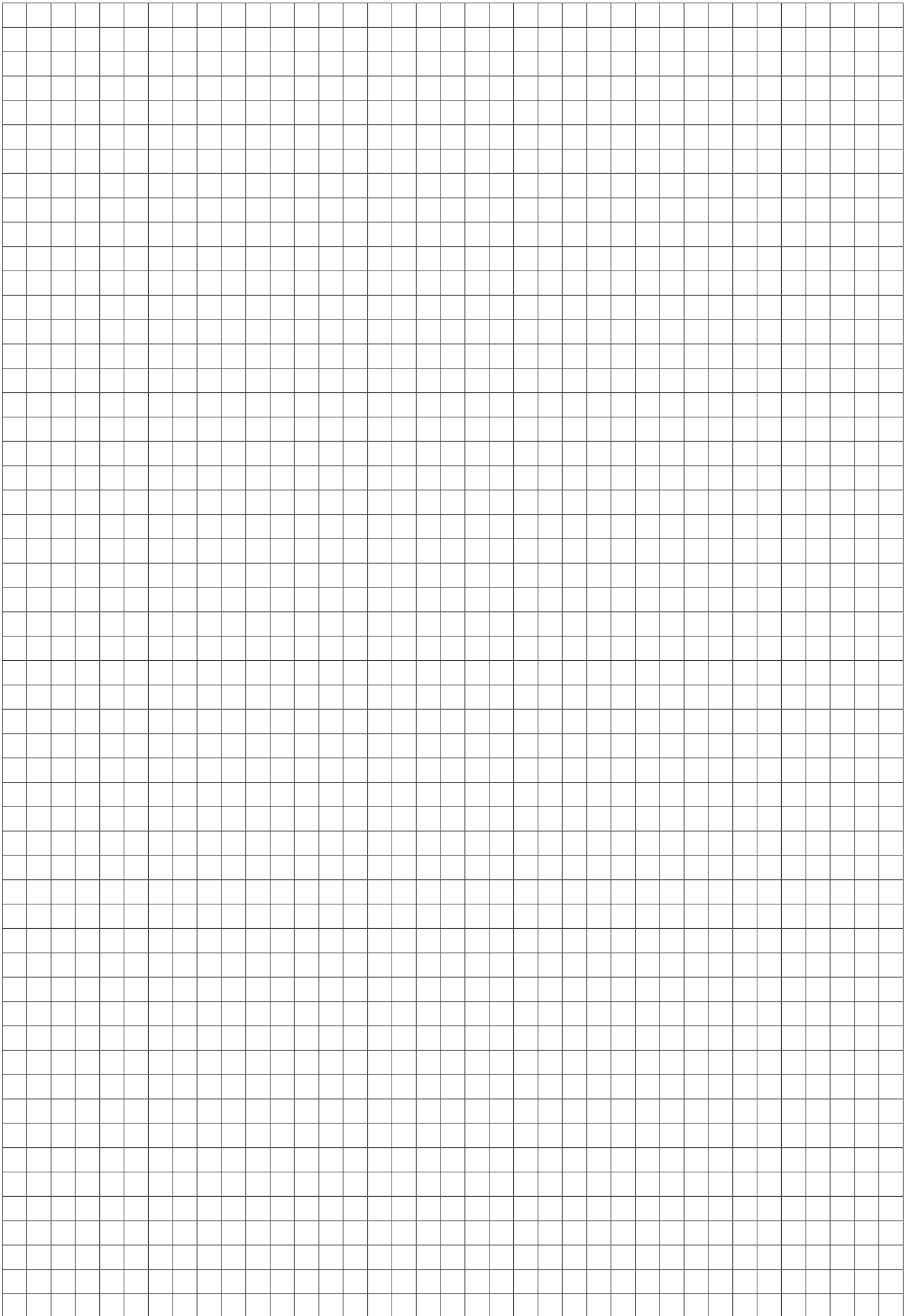

## Solenoid valves series 3000

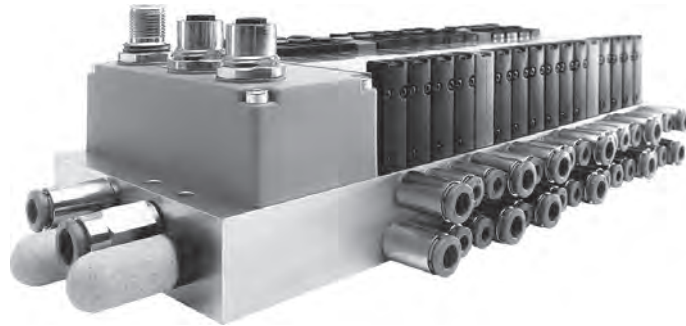

- 10 mm size
- Nominal flow rate up to 200 NI/min
- Available sub-base mounted or with M5 threaded ports
- The ability to replace valves without disconnecting the pipework
- Available with a wide range of serial system protocols
- Wide range of accessories
- Stand-alone or manifold mounted versions
- Suitable for use with pressure or vacuum

Versatility and maximum reliability: With these prerogatives in mind, new products are being developed dedicated to control in a smarter context. Having the flexibility to be configured within control systems to provide optimal management through a constant interface and communication with the machines control system. The Pneumax 3000 series solenoid valve range has been developed with this in mind and has been developed to suit both stand-alone and manifold mounted applications.

Both stand alone and manifold mounted versions are available in the most commonly used types, capable of working with positive pressures up to 10 Bar or vacuum. The valves have aluminum bodies with integrated electrical connections, manual override and an LED that indicates when the valve is actuated. The Pneumax 3000 series is another addition to the extensive range of solenoid valve systems designed for applications from assembly to automotive.

Construction characteristics	
Body	Aluminium
Operators	Technopolymer
Spool	Aluminium
Seals	NBR
Piston seals	NBR
Springs	AISI 302 stainless steel
Pistons	Aluminium
Operational characteristics	
Voltage	24 VDC $\pm$ 10%
Pilot power consumption	1.3W nominal in the STAND ALONE version (M8 version 1.3W with energy saving) 1.3W nominal in energy saving mode in the MANIFOLD version.
Valve working pressure [1]	from vacuum to 10 bar max.
Pilot working pressure [12-14]	from 2,5 to 7 bar max.
Operating temperature	from -5°C to +50°C
Fluid	Filtered air. No lubrication needed, if applied it shall be continuous



STAND ALONE solenoid valves version



1 AIR DISTRIBUTION

**General**

The 10mm solenoid valves range with a flow of 200 NI/min, is available in STAND ALONE self-feeding or external feeding versions and realised with point to point connections in three different types of interface: with miniature connector type H, with 300mm leads and with an M8 connector with an integrated snap-on fitting.

**Main characteristics**

10 mm size thick.  
Multi-position sub-bases in different lengths.

**Functions**

- S.V. 5/2 Monostable Solenoid-Spring
- S.V. 5/2 Monostable Solenoid-Differential (only self feeding)
- S.V. 5/2 Bistable Solenoid-Solenoid
- S.V. 5/3 C.C. Solenoid-Solenoid
- S.V. 2x3/2 N.C.-N.C. (= 5/3 O.C.) Solenoid-Solenoid
- S.V. 2x3/2 N.O.-N.O. (= 5/3 P.C.) Solenoid-Solenoid
- S.V. 2x3/2 N.C.-N.O. Solenoid-Solenoid
- S.V. 2x3/2 N.O.-N.C. Solenoid-Solenoid

**Solenoid valve ordering code**

3115. 52.00 . 39 . 02

Function
52.00: Solenoid valve 5/2
53.31: Solenoid valve 5 way 3 positions
62.44: 2x Solenoid valve 3/2 N.C.-N.C.
62.55: 2x Solenoid valve 3/2 N.O.-N.O.
62.45: 2x Solenoid valve 3/2 N.C.-N.O.
62.54: 2x Solenoid valve 3/2 N.O.-N.C.
Valves type
36: Solenoid - Differential self-feeding
39: Solenoid - Spring self-feeding
35: Solenoid - Solenoid self-feeding
29: Solenoid - Spring external feeding
25: Solenoid - Solenoid external feeding
Connection
02: H 90° connector
32: 300 mm cables
82: M8 SPEED-UP connector

Example in the table : 3115.52.00.39.02 : Solenoid valve 5/2 solenoid-spring self-feeding, H 90° connector



Configurator

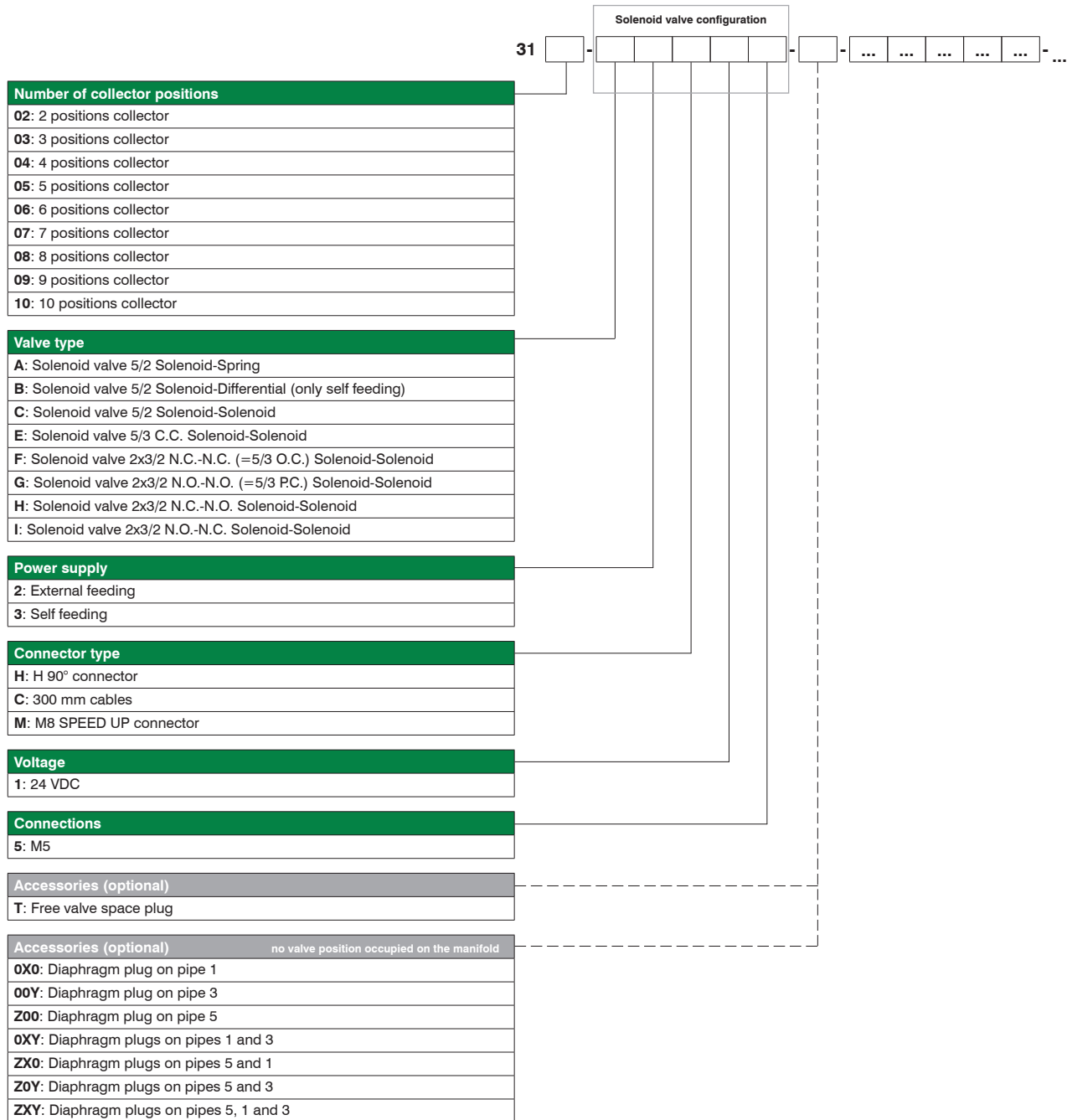

1  
AIR DISTRIBUTION

**Example in the table : 3104-C2H15-T-0X0-A3H15-F3M15**

Four-position manifold composed of:

- Solenoid valve 5/2 solenoid-solenoid external feeding, H90° connector, 24 VDC
- Free valve space plug
- Diaphragm plug on pipe 1
- Solenoid valve 5/2 solenoid-spring self-feeding, H90° connector, 24 VDC
- Solenoid valve 2x3/2 N.C.-N.C. (=5/3 O.C.) solenoid-solenoid, M8 SPEED UP connector, 24 VDC



**Solenoid valves manifold**  
**Series 3000 STAND ALONE - 10mm, M5 - Self feeding**

**Solenoid-Spring / Solenoid-Differential**

Coding: 3115.52.00. **F** **C**

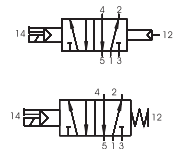
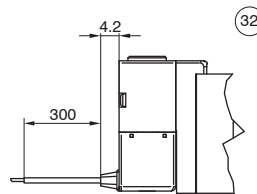
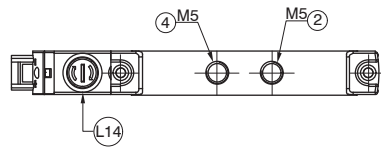
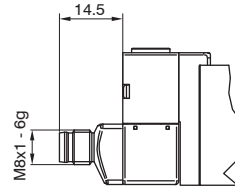
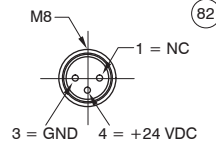
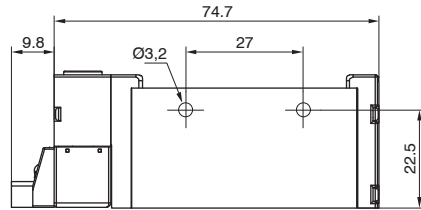

SHORT FUNCTION CODE "A" (39)  
 SHORT FUNCTION CODE "B" (36)

L14 = Manual over ride - Side 14

Operational characteristics		*Shifting time of pneumatic directional control valves or moving parts, logic devices were measured in accordance to ISO 12238:2001*					
Code	Fluid	Flow rate at 6 bar with $\Delta p=1$ (NI/min)	Response time according to ISO 12238, activation time (ms)	Response time according to ISO 12238, deactivation time (ms)	Piloting pressure (bar)	Temperature °C	Weight (g)
3115.52.00.39. <b>C</b> Solenoid-Spring	Filtered air. No lubrication needed, if applied it shall be continuous	160	10	20	2.5 - 7	-5 - +50	49
3115.52.00.36. <b>C</b> Solenoid-Differential				15			

**Solenoid - Solenoid**

Coding: 3115.52.00.35. **C**

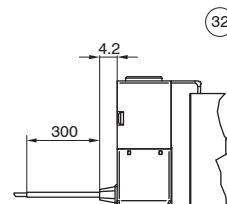
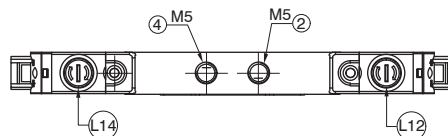
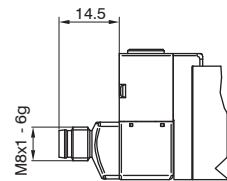
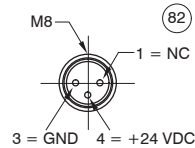
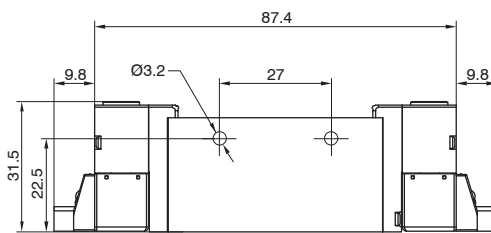

SHORT FUNCTION CODE "C"

L12 = Manual over ride - Side 12  
 L14 = Manual over ride - Side 14

Operational characteristics		*Shifting time of pneumatic directional control valves or moving parts, logic devices were measured in accordance to ISO 12238:2001*					
Code	Fluid	Flow rate at 6 bar with $\Delta p=1$ (NI/min)	Response time according to ISO 12238, activation time (ms)	Response time according to ISO 12238, deactivation time (ms)	Piloting pressure (bar)	Temperature °C	Weight (g)
3115.52.00.35. <b>C</b> Solenoid-Differential	Filtered air. No lubrication needed, if applied it shall be continuous	160	10	20	2.5 - 7	-5 - +50	59



Solenoid - Solenoid (Closed centres)

Coding: 3115.53.31.35.Ⓒ

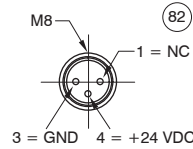
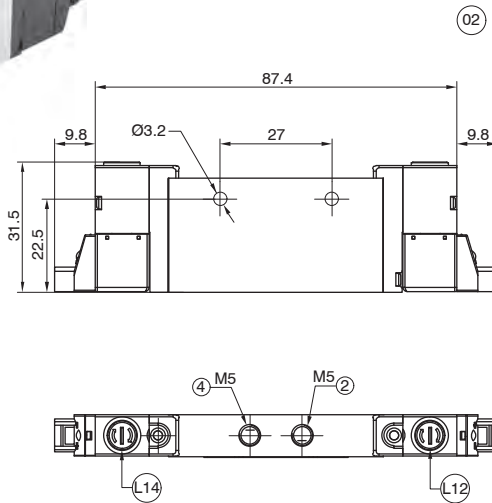

CONNECTIONS	
02	H 90° connector, 24 VDC
32	300mm cable, 24 VDC
82	M8 SPEED UP connector 24VDC

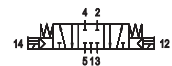
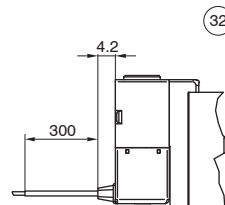
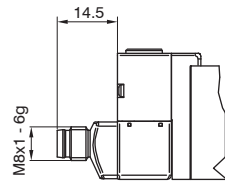

SHORT FUNCTION CODE "E"

L12 = Manual over ride - Side 12  
L14 = Manual over ride - Side 14

Operational characteristics		*Shifting time of pneumatic directional control valves or moving parts, logic devices were measured in accordance to ISO 12238:2001*					
Code	Fluid	Flow rate at 6 bar with $\Delta p=1$ (Nl/min)	Response time according to ISO 12238, activation time (ms)	Response time according to ISO 12238, deactivation time (ms)	Piloting pressure (bar)	Temperature °C	Weight (g)
3115.53.31.35.Ⓒ Solenoid-Solenoid (Closed centres)	Filtered air. No lubrication needed, if applied it shall be continuous	150	10	20	2.5 - 7	-5 - +50	59

Solenoid - Solenoid 2x3/2

Coding: 3115.62.Ⓕ.35.Ⓒ

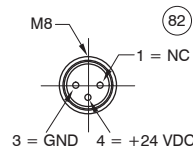
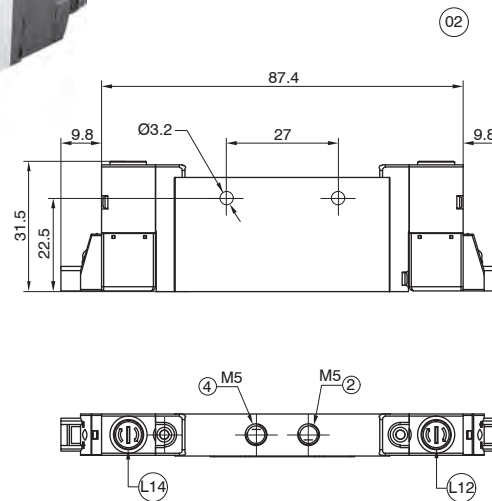

FUNCTION	
44	NC-NC (5/3 Open centres)
Ⓕ	45=NC-NO
	55=NO-NO (5/3 Pressured centres)
	54=NO-NC
CONNECTIONS	
02	H 90° connector, 24 VDC
32	300mm cable, 24 VDC
82	M8 SPEED UP connector 24VDC

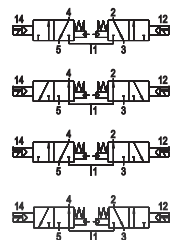
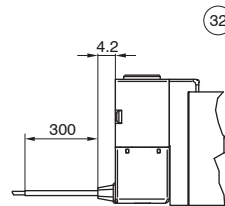
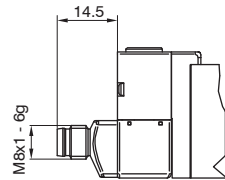

SHORT FUNCTION CODE:  
NC-NC (5/3 Open centres) = "F"  
NO-NO (5/3 Pressured centres) = "G"  
NC-NO = "H"  
NO-NC = "I"

L12 = Manual over ride - Side 12  
L14 = Manual over ride - Side 14

Operational characteristics		*Shifting time of pneumatic directional control valves or moving parts, logic devices were measured in accordance to ISO 12238:2001*					
Code	Fluid	Flow rate at 6 bar with $\Delta p=1$ (Nl/min)	Response time according to ISO 12238, activation time (ms)	Response time according to ISO 12238, deactivation time (ms)	Piloting pressure (bar)	Temperature °C	Weight (g)
3115.62.44.35.Ⓒ NC-NC (5/3 Open centres)	Filtered air. No lubrication needed, if applied it shall be continuous	150	10	15	2.5 - 7	-5 - +50	59,4
3115.62.55.35.Ⓒ NO-NO (5/3 Pressured centres)							
3115.62.45.35.Ⓒ NC-NO							
3115.62.54.35.Ⓒ NO-NC							



# Solenoid valves manifold Series 3000 STAND ALONE - 10mm, M5 - External feeding

AIR DISTRIBUTION

## Solenoid-Spring

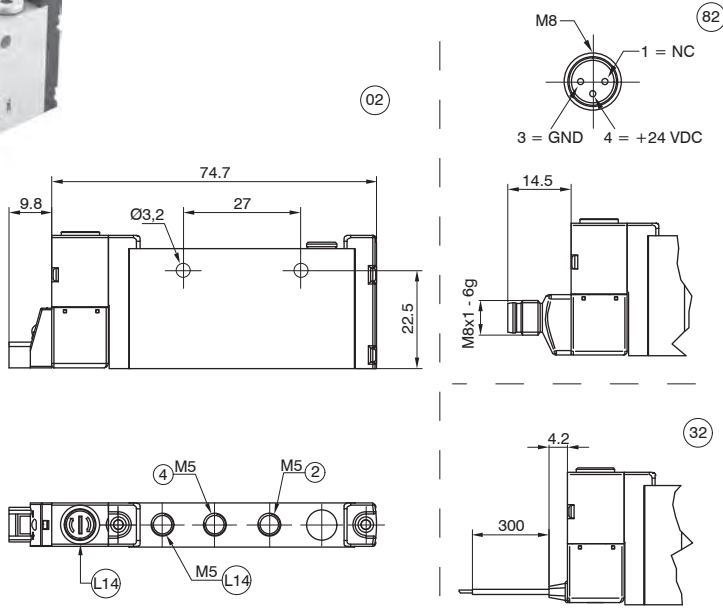

Coding: 3115.52.00.29. **C**

CONNECTIONS	
02=H 90° connector, 24 VDC	
<b>C</b> 32=300mm cable, 24 VDC	
82=M8 SPEED UP connector 24VDC	

SHORT FUNCTION CODE "A" (29)

L12 = Manual over ride - Side 12  
L14 = Manual over ride - Side 14

Operational characteristics		*Shifting time of pneumatic directional control valves or moving parts, logic devices were measured in accordance to ISO 12238:2001*						
Code	Fluid	Flow rate at 6 bar with $\Delta p=1$ (NI/min)	Response time according to ISO 12238, activation time (ms)	Response time according to ISO 12238, deactivation time (ms)	Working pressure (bar)	Piloting pressure (bar)	Temperature °C	Weight (g)
3115.52.00.29. <b>C</b> Solenoid-Spring	Filtered air. No lubrication needed, if applied it shall be continuous	160	10	20	From vacuum to 10	2,5 - 7	-5 - +50	49

## Solenoid - Solenoid

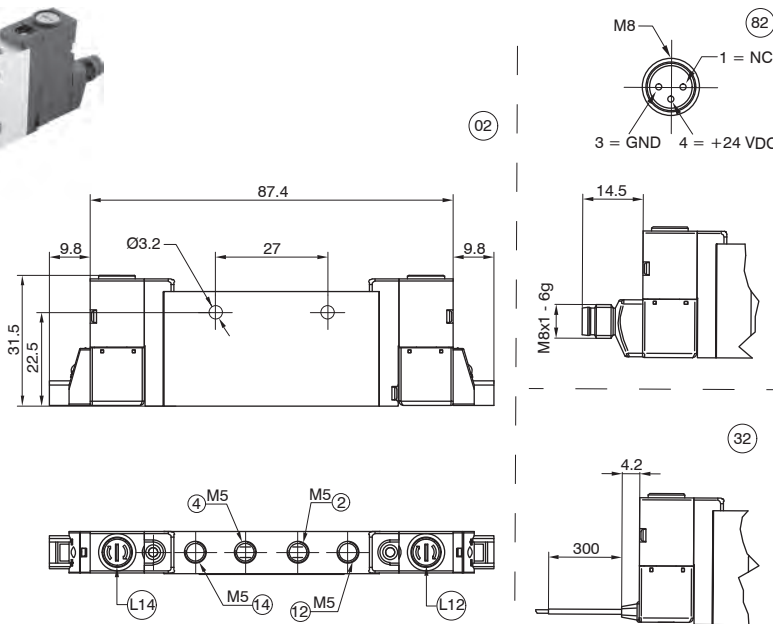

Coding: 3115.52.00.25. **C**

CONNECTIONS	
02=H 90° connector, 24 VDC	
<b>C</b> 32=300mm cable, 24 VDC	
82=M8 SPEED UP connector 24VDC	

SHORT FUNCTION CODE "C"

L12 = Manual over ride - Side 12  
L14 = Manual over ride - Side 14

Operational characteristics		*Shifting time of pneumatic directional control valves or moving parts, logic devices were measured in accordance to ISO 12238:2001*						
Code	Fluid	Flow rate at 6 bar with $\Delta p=1$ (NI/min)	Response time according to ISO 12238, activation time (ms)	Response time according to ISO 12238, deactivation time (ms)	Working pressure (bar)	Piloting pressure (bar)	Temperature °C	Weight (g)
3115.52.00.25. <b>C</b> Solenoid-Solenoid	Filtered air. No lubrication needed, if applied it shall be continuous	160	10	10	From vacuum to 10	2,5 - 7	-5 - +50	59

Solenoid - Solenoid 5/3 (Closed centres)

Coding: 3115.53.31.25. **C**

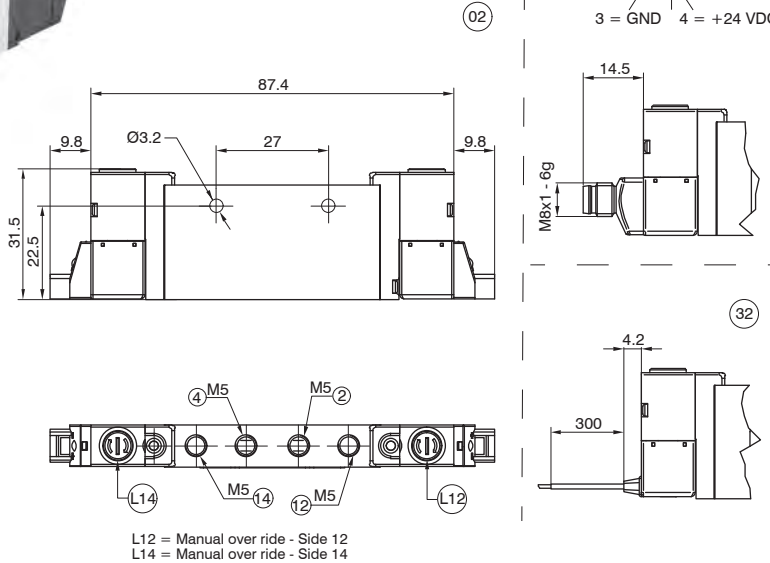

CONNECTIONS	
02	H 90° connector, 24 VDC
32	300mm cable, 24 VDC
82	M8 SPEED UP connector 24VDC

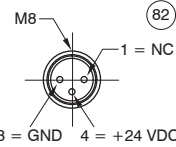

SHORT FUNCTION CODE "E"

L12 = Manual over ride - Side 12  
L14 = Manual over ride - Side 14

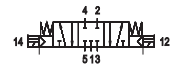

Operational characteristics		*Shifting time of pneumatic directional control valves or moving parts, logic devices were measured in accordance to ISO 12238:2001*						
Code	Fluid	Flow rate at 6 bar with $\Delta p=1$ (NI/min)	Response time according to ISO 12238, activation time (ms)	Response time according to ISO 12238, deactivation time (ms)	Working pressure (bar)	Piloting pressure (bar)	Temperature °C	Weight (g)
3115.53.31.25. <b>C</b> Solenoid-Solenoid 5/3 (Closed centres)	Filtered air. No lubrication needed, if applied it shall be continuous	150	10	20	From vacuum to 10	2,5 - 7	-5 - +50	59

Solenoid - Solenoid 2x3/2

Coding: 3115.62.F.25. **C**

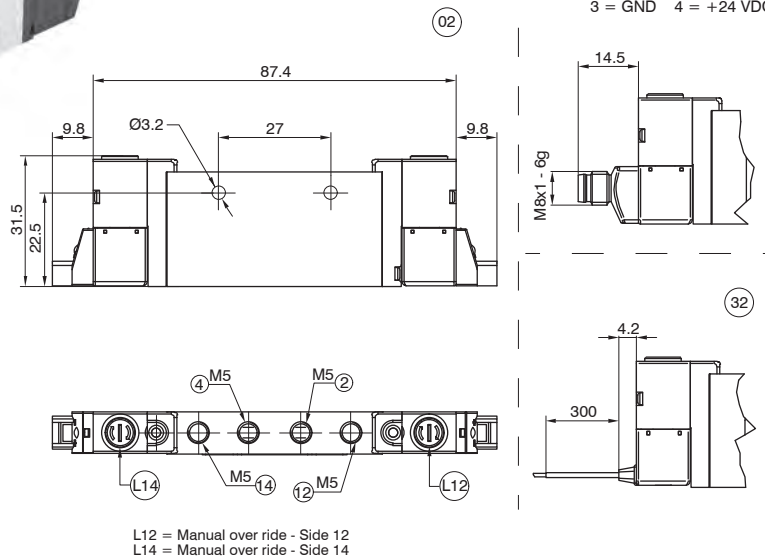

FUNCTION	
44	NC-NC (5/3 Open centres)
<b>F</b> 45	NC-NO
55	NO-NO (5/3 Pressured centres)
54	NO-NC
CONNECTIONS	
02	H 90° connector, 24 VDC
<b>C</b> 32	300mm cable, 24 VDC
82	M8 SPEED UP connector 24VDC

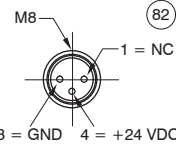

SHORT FUNCTION CODE:  
NC-NC (5/3 Open centres) = "F"  
NO-NO (5/3 Pressured centres) = "G"  
NC-NO = "H"  
NO-NC = "I"

L12 = Manual over ride - Side 12  
L14 = Manual over ride - Side 14

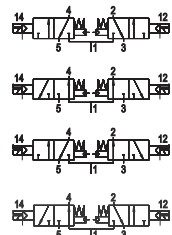

Operational characteristics		*Shifting time of pneumatic directional control valves or moving parts, logic devices were measured in accordance to ISO 12238:2001*						
Code	Fluid	Flow rate at 6 bar with $\Delta p=1$ (NI/min)	Response time according to ISO 12238, activation time (ms)	Response time according to ISO 12238, deactivation time (ms)	Working pressure (bar)	Piloting pressure (bar)	Temperature °C	Weight (g)
3115.62.44.25. <b>C</b> NC-NC (5/3 Open centres)	Filtered air. No lubrication needed, if applied it shall be continuous	150	10	15	From vacuum to 10	≥3+ (02x Inlet press.)	-5 - +50	59,4
3115.62.55.25. <b>C</b> NO-NO (5/3 Pressured centres)								
3115.62.45.25. <b>C</b> NC-NO								
3115.62.54.25. <b>C</b> NO-NC								



**Solenoid valves manifold**  
**Series 3000 STAND ALONE - 10mm, M5 - Accessories**

**Manifold**

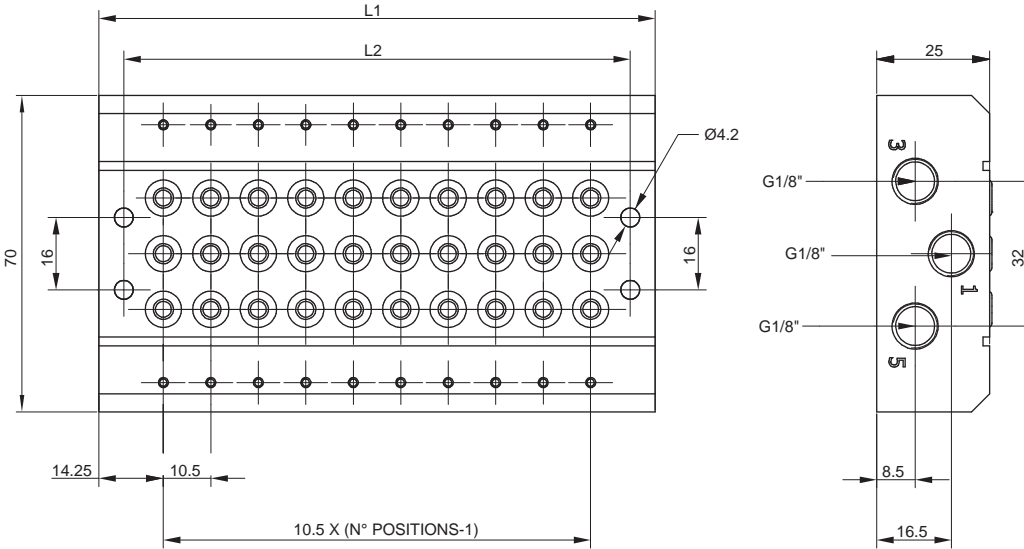

**Coding: 3115.P**

POSITIONS	L1	L2
02=2 POSITIONS (weight 150 g)	39	29
03=3 POSITIONS (weight 200 g)	49,5	39,5
04=4 POSITIONS (weight 250 g)	60	50
05=5 POSITIONS (weight 300 g)	70,5	60,5
<b>P</b> 06=6 POSITIONS (weight 350 g)	81	71
07=7 POSITIONS (weight 400 g)	91,5	81,5
08=8 POSITIONS (weight 450 g)	102	92
09=9 POSITIONS (weight 500 g)	112,5	102,5
10=10 POSITIONS (weight 550 g)	123	113

AIR DISTRIBUTION

1

**Assembling kit**



**Coding: 3115.KV**

Weight 2 g

**Closing plate**

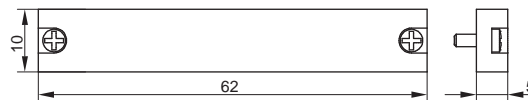

**Coding: 3115.00**

Weight 10 g

**Diaphragm plug**



**Coding: 3130.17**

Weight 1,5 g



Solenoid valve description

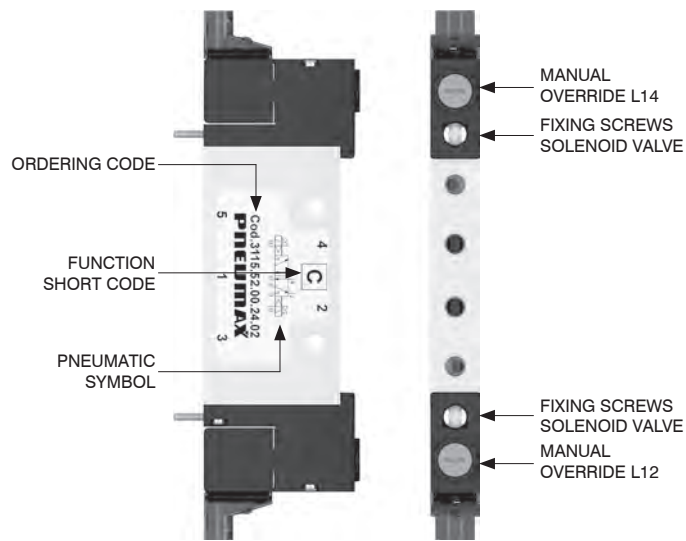

From the top

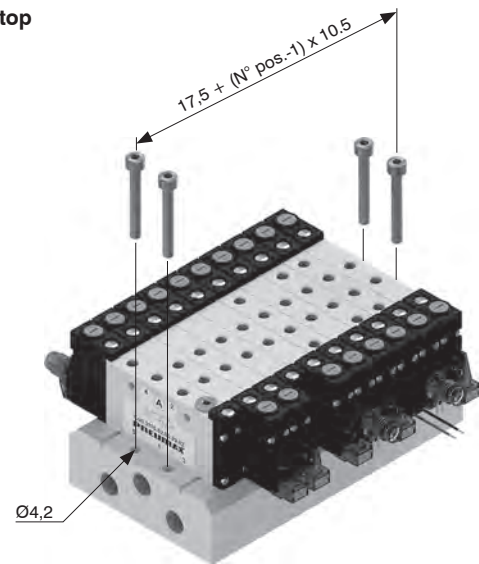

1  
AIR DISTRIBUTION

DIN rail fixing

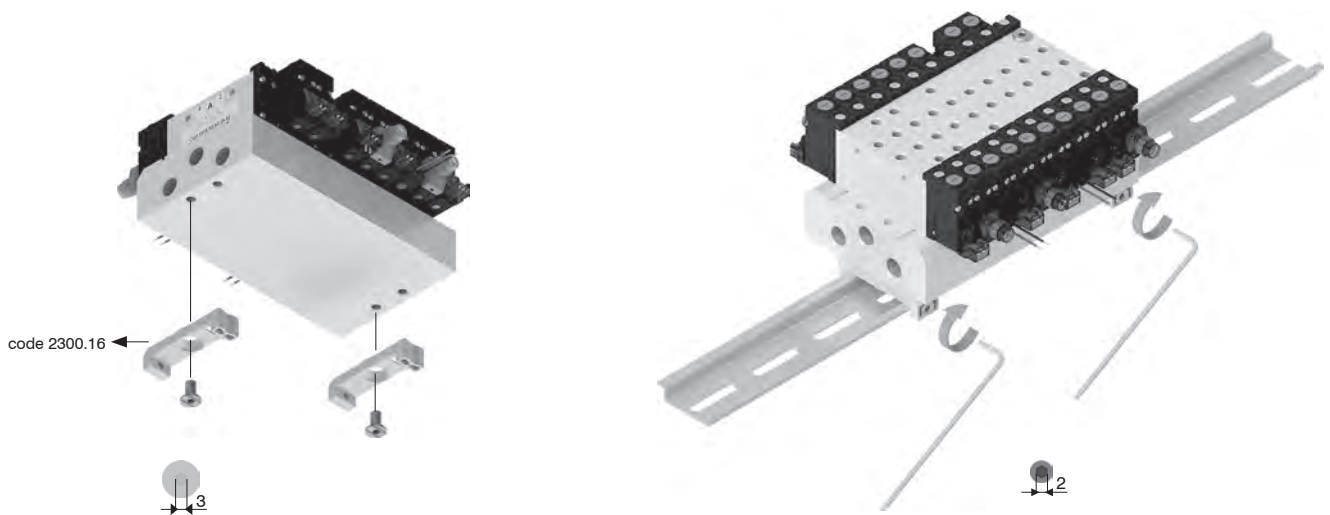

Supply ports and maximum possible size according to valves used

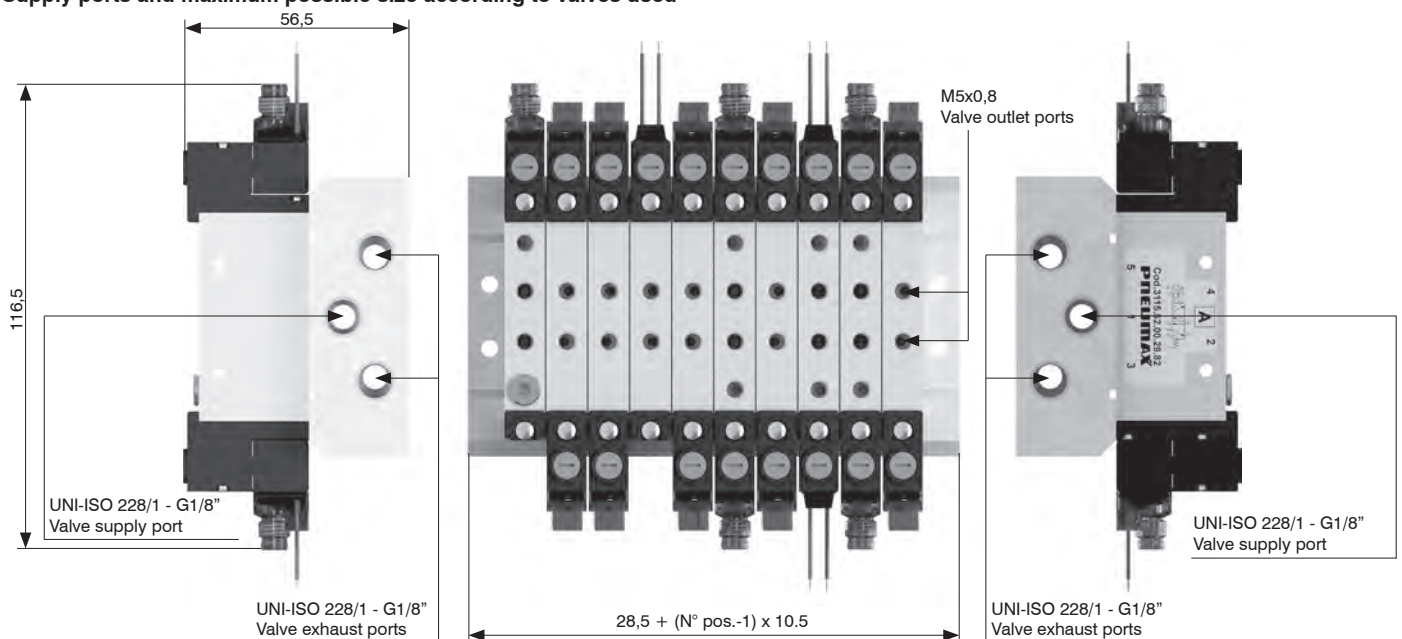

Manual override actuation

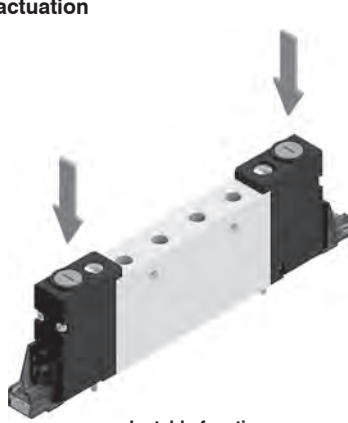

**Instable function:**  
Push to actuate  
(when released it moves back  
to the original position)

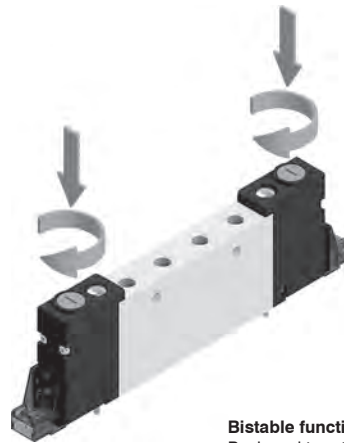

**Bistable function:**  
Push and turn to get the bistable  
function

**Note:** it is strongly suggested to replace the original position after using

Solenoid valves installation

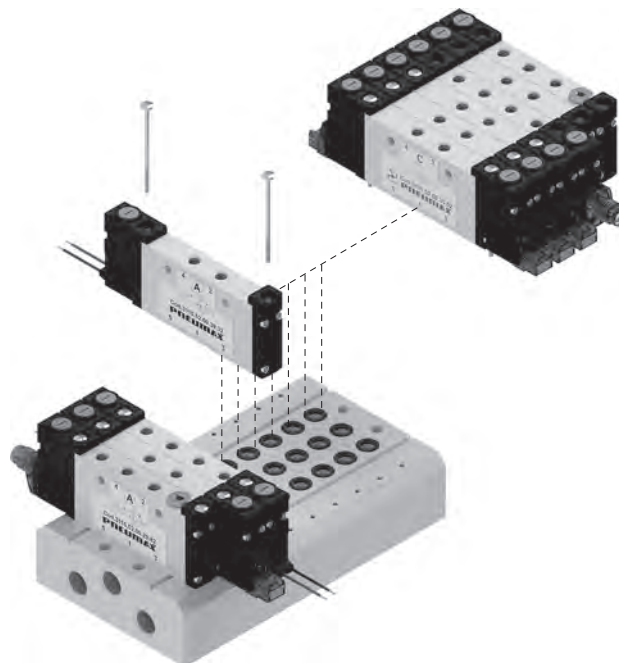

Max. torque moment: 0,2 Nm

1  
AIR DISTRIBUTION

## MANIFOLD version

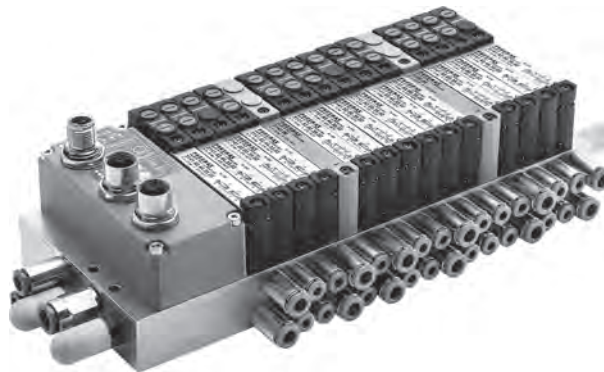

### General

The range of solenoid valves, dedicated to the assembly sector in pre-configured manifold, is available in multipolar and serial versions, thanks to a vast choice of connectors and analogue and digital input and output accessories. The compact and clean design of both the valve body and the manifold, each one produced in aluminium, allows their use in applications requiring space optimisation and weight reduction without sacrificing the reliability and the characteristics of aluminium. The multipolar version is available in three different types of connections:

- SUB-D 25 poles equipped with 24 outputs and configurable in different lengths up to manifolds with a maximum of 12 bistable valve positions
- SUB-D 37 poles equipped with 32 outputs and configurable in different lengths up to manifolds with a maximum of 16 bistable valve positions
- SUB-D 25 poles HD (44 poles) equipped with 40 outputs and configurable in different lengths up to manifolds with a maximum of 20 bistable valve positions

Every one of these options covers the wide range of application requirements and provides electronic management by default capable of energy saving on individual coils and managing PNP and NPN connections automatically without any difference in installation for the end user.

Precisely in order to guarantee maximum versatility in integration in different machines and applications, the 3000 series valves in the serial version are designed to interface with all the main communication protocols: CANopen®, EtherCAT®, PROFINET IO RT/IRT, EtherNet/IP, Powerlink, PROFIBUS DP and IO-Link.

Each manifold has also been thought out in order to be extremely flexible in the management or addition of further outputs through the use of a sub-base system that expands the main manifold.

This system of sub-bases can be connected through the use of a specific kit of connecting pins which can be repeated modularly until reaching the maximum number of outputs managed by the serial protocol used.

Taking advantage of the expansion of the output signals it is possible to connect other components to manage, for example, proportional pressure regulation or to control other solenoid valves.

With the same system it is also possible to connect a series of modules to the main manifold dedicated to the management of input signals up to the maximum number of inputs manageable by the specific serial node used.

In fact, input modules with different interfaces and different technologies have been provided, that is: modules with eight digital inputs with M8 or M12 connection or; analogue or voltage input modules with M8 connection interface.

The strong point of this system is the possibility to configure the series of input and output modules freely giving the advantage of installation flexibility.

### Main characteristics

10 mm size thick.

Multi-position sub-bases in different lengths.

Integrated and optimized electrical connection as standard

### Functions

S.V. Monostable Solenoid-Spring

S.V. Monostable Solenoid-Differential

S.V. 5/2 Bistable Solenoid-Solenoid

S.V. 5/3 C.C. Solenoid-Solenoid

S.V. 2x3/2 N.C.-N.C. (= 5/3 O.C.) Solenoid-Solenoid

S.V. 2x3/2 N.O.-N.O. (= 5/3 P.C) Solenoid-Solenoid

S.V. 2x3/2 N.C.-N.O. Solenoid-Solenoid

S.V. 2x3/2 N.O.-N.C. Solenoid-Solenoid



Configurator

1  
AIR DISTRIBUTION



Power supply	
A:	Self-feeding
E:	External feeding

Electric connection	
MP2:	25 poles multipoint module
MP3:	37 poles multipoint module
MP4:	44 poles HD multipoint module
C3:	CANopen® module 64 IN - 64 OUT (32 fixed)
C4:	CANopen® module 64 IN - 64 OUT (48 fixed)
P3:	PROFIBUS DP module 64 IN - 64 OUT (32 fixed)
P4:	PROFIBUS DP module 64 IN - 64 OUT (48 fixed)
I4:	EtherNet/IP module 128 IN - 128 OUT (48 fixed)
A4:	EtherCAT® module 128 IN - 128 OUT (48 fixed)
N4:	PROFINET IO RT/IRT module 128 IN - 128 OUT (48 fixed)
K3:	IO-Link module 64 IN - 64 OUT (32 fixed)
K4:	IO-Link module 64 IN - 64 OUT (48 fixed)

Inputs module - Analog / Digital (Optional)	
D8:	8 M8 digital inputs module
D12:	8 M12 digital inputs module
D3:	32 digital inputs SUB-D 37 pins
T1:	2 analogue inputs 0-5V module (voltage signal)
T2:	2 analogue inputs 0-10V module (voltage signal)
T3:	4 analogue inputs 0-5V module (voltage signal)
T4:	4 analogue inputs 0-10V module (voltage signal)
C1:	2 analogue inputs 0-20mA module (current signal)
C2:	2 analogue inputs 4-20mA module (current signal)
C3:	4 analogue inputs 0-20mA module (current signal)
C4:	4 analogue inputs 4-20mA module (current signal)
P1:	2 Pt100 2 wires inputs module
P2:	2 Pt100 3 wires inputs module
P3:	2 Pt100 4 wires inputs module
P4:	4 Pt100 2 wires inputs module
P5:	4 Pt100 3 wires inputs module
P6:	4 Pt100 4 wires inputs module

Outputs module - Analog / Digital (Optional)	
M8:	8 M8 digital outputs module
M12:	8 M12 digital outputs module
M3:	32 digital outputs SUB-D 37 pins
V1:	2 analogue outputs 0-5V module (voltage signal)
V2:	2 analogue outputs 0-10V module (voltage signal)
V3:	4 analogue outputs 0-5V module (voltage signal)
V4:	4 analogue outputs 0-10V module (voltage signal)
L1:	2 analogue outputs 0-20mA module (current signal)
L2:	2 analogue outputs 4-20mA module (current signal)
L3:	4 analogue outputs 0-20mA module (current signal)
L4:	4 analogue outputs 4-20mA module (current signal)

Additional power supply module (Optional)	
P12:	M12 additional power supply module
J0:	Optional position module

Valves type	
A:	Solenoid valve 5/2 Solenoid - Spring
B:	Solenoid valve 5/2 Solenoid - Differential
C:	Solenoid valve 5/2 Solenoid - Solenoid
E:	Solenoid valve 5/3 C.C. Solenoid - Solenoid
F:	Solenoid valve 2X3/2 N.C.-N.C. (=5/3 O.C.) Solenoid - Solenoid
G:	Solenoid valve 2X3/2 N.O.-N.O. (=5/3 P.C.) Solenoid - Solenoid
H:	Solenoid valve 2X3/2 N.C.-N.O. Solenoid - Solenoid
I:	Solenoid valve 2X3/2 N.O.-N.C. Solenoid - Solenoid
T:	Closing plate
X:	Diaphragm plug on pipe 1
Y:	Diaphragm plug on pipe 3
Z:	Diaphragm plug on pipe 5
W:	Intermediate supply and exhaust module



Configuration examples

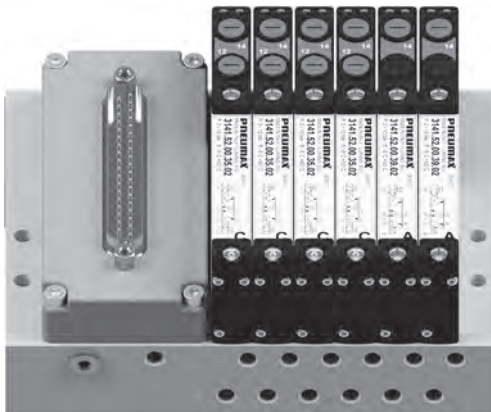

**Example shown : 31EMP3CCCCAA**  
Manifold with external feeding, multipolar; 37 poles and solenoid valves.

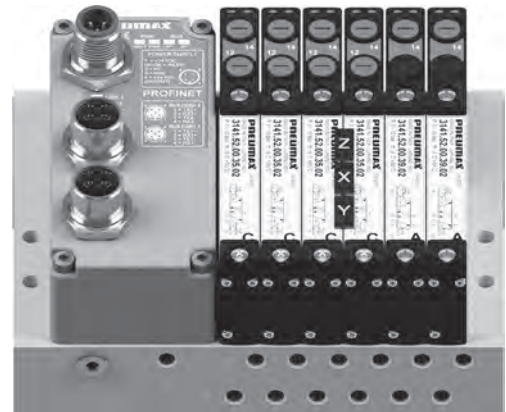

**Example shown : 31EN4CCCXYZCAA**  
Manifold with external feeding, serial module, solenoid valves and diaphragm plugs.

1  
AIR DISTRIBUTION

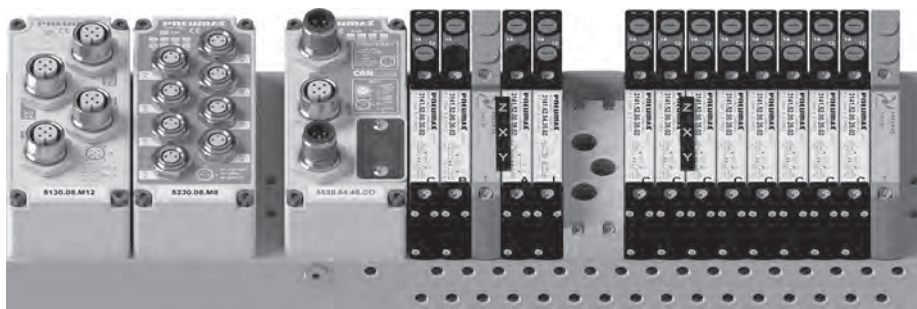

**Example shown : 31EC4D8M12CBTXYZAIWCCXYZCCCCCT**  
Manifold with external feeding, serial module, M8 input module, M12 output module; solenoid valves, multi-position diaphragm plugs, additional power supply module.



**Example shown : 31AC4D8D8M12J0CBIIIITT**  
Self-feeding manifold with serial module, M8 input module, M12 output module, optional position module, solenoid valves.

**Solenoid - Spring / Solenoid - Differential**

Coding: 3141.52.00. **F** **C**

FUNCTION	
<b>F</b>	36= Solenoid - Differential
	39= Solenoid-Spring
CONNECTIONS	
<b>C</b>	02=24VDC

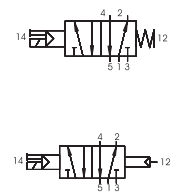
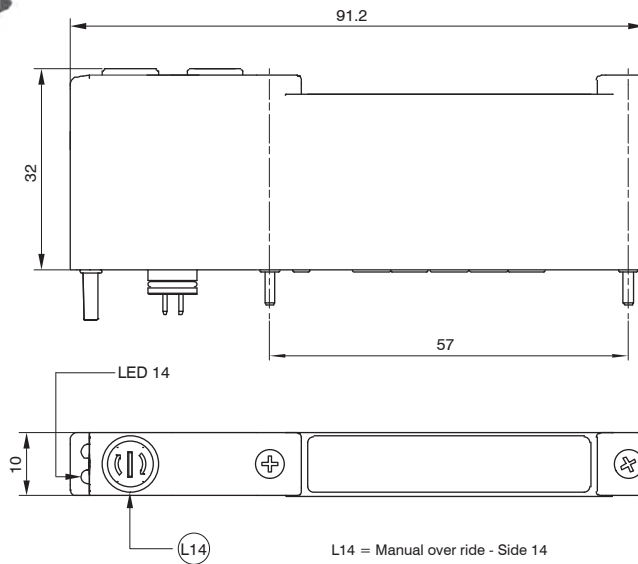

SHORT FUNCTION CODE "A" (39)  
SHORT FUNCTION CODE "B" (36)

L14 = Manual over ride - Side 14

Operational characteristics		"Shifting time of pneumatic directional control valves or moving parts, logic devices were measured in accordance to ISO 12238:2001"						
Code	Fluid	Flow rate at 6 bar with $\Delta p=1$ (NI/min)	Response time according to ISO 12238, activation time (ms)	Response time according to ISO 12238, deactivation time (ms)	Working pressure (bar)	Piloting pressure (bar)	Temperature °C	Weight (g)
3141.52.00.39. <b>C</b> Solenoid-Spring	Filtered air. No lubrication needed, if applied it shall be continuous	200	10	20	From vacuum to 10	2,5 - 7	-5 - +50	55,7
3141.52.00.36. <b>C</b> Solenoid-Differential								

**Solenoid - Solenoid**

Coding: 3141.52.00.35. **C**

CONNECTIONS	
<b>C</b>	02=24VDC

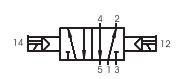
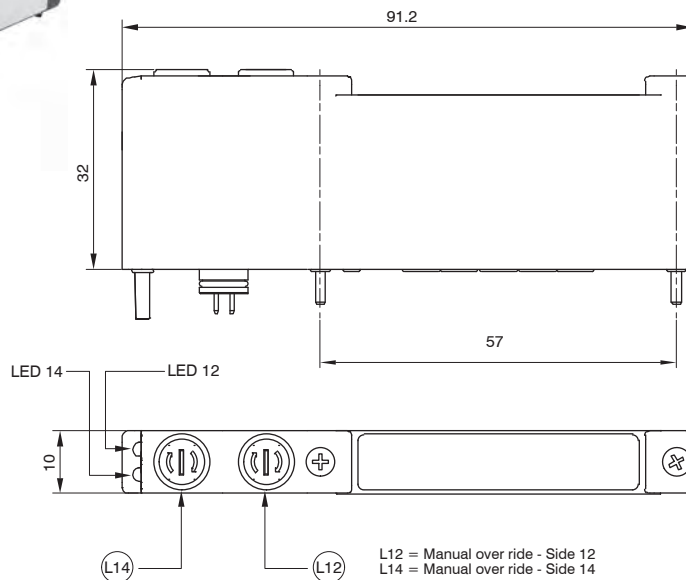

SHORT FUNCTION CODE "C"

L12 = Manual over ride - Side 12  
L14 = Manual over ride - Side 14

Operational characteristics		"Shifting time of pneumatic directional control valves or moving parts, logic devices were measured in accordance to ISO 12238:2001"						
Code	Fluid	Flow rate at 6 bar with $\Delta p=1$ (NI/min)	Response time according to ISO 12238, activation time (ms)	Response time according to ISO 12238, deactivation time (ms)	Working pressure (bar)	Piloting pressure (bar)	Temperature °C	Weight (g)
3141.52.00.35. <b>C</b> Solenoid-Solenoid	Filtered air. No lubrication needed, if applied it shall be continuous	200	10	10	From vacuum to 10	2,5 - 7	-5 - +50	55,7

Solenoid - Solenoid 5/3 (Closed centres)

Coding: 3141.53.31.35. **C**

<b>C</b>	CONNECTIONS
	02=24VDC

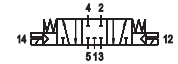
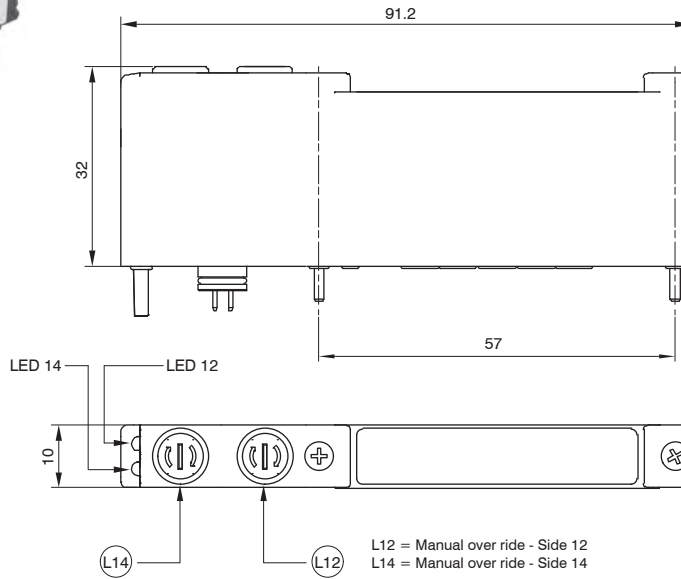

SHORT FUNCTION CODE "E"

Operational characteristics		*Shifting time of pneumatic directional control valves or moving parts, logic devices were measured in accordance to ISO 12238:2001*						
Code	Fluid	Flow rate at 6 bar with $\Delta p=1$ (NI/min)	Response time according to ISO 12238, activation time (ms)	Response time according to ISO 12238, deactivation time (ms)	Working pressure (bar)	Piloting pressure (bar)	Temperature °C	Weight (g)
3141.53.31.35. <b>C</b> Solenoid-Solenoid 5/3 (Closed centres)	Filtered air. No lubrication needed, if applied it shall be continuous	170	10	20	From vacuum to 10	2,5 - 7	-5 - +50	60,3

Solenoid - Solenoid 2x3/2

Coding: 3141.62. **F**.35. **C**

<b>F</b>	FUNCTION
	44=NC-NC (5/3 Open centres)
	45=NC-NO
	55=NO-NO 5/3 (Pressured centres)
	54=NO-NC
<b>C</b>	CONNECTIONS
	02=24VDC

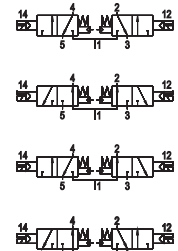
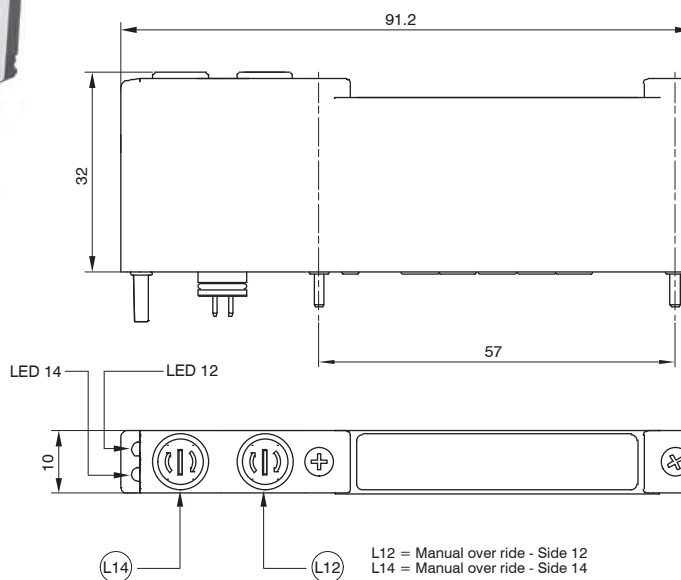

SHORT FUNCTION CODE:  
NC-NC (5/3 Open centres) = "F"  
NO-NO (5/3 Pressured centres) = "G"  
NC-NO = "H"  
NO-NC = "I"

Operational characteristics		*Shifting time of pneumatic directional control valves or moving parts, logic devices were measured in accordance to ISO 12238:2001*						
Code	Fluid	Flow rate at 6 bar with $\Delta p=1$ (NI/min)	Response time according to ISO 12238, activation time (ms)	Response time according to ISO 12238, deactivation time (ms)	Working pressure (bar)	Piloting pressure (bar)	Temperature °C	Weight (g)
3141.62.44.35. <b>C</b> NC-NC (5/3 Open centres)	Filtered air. No lubrication needed, if applied it shall be continuous	170	10	15	From vacuum to 10	$\geq 3+$ (02x Inlet press.)	-5 - +50	60,7
3141.62.45.35. <b>C</b> NC-NO								
3141.62.55.35. <b>C</b> NO-NO (5/3 Pressured centres)								
3141.62.54.35. <b>C</b> NO-NC								



**Multipoint module**

Codifica: 3140.00.C

Operational characteristics			
Code	3140.00.25P (25 poles)	3140.00.37P (37 poles)	3140.00.44P (44 poles)
Temperature °C	-5 - +50		
Weight (g)	47,4	51,3	49,1

ELECTRICAL CONNECTIONS	
25P=Connector 25 poles	
37P=Connector 37 poles	
44P=Connector 44 poles	

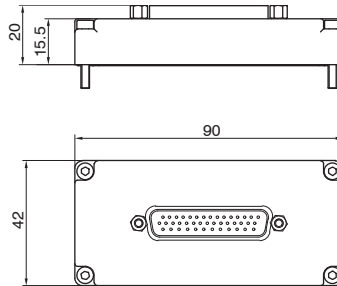

1 AIR DISTRIBUTION

25 POLES MULTIPOINT MODULE  
12 SOLENOID VALVES  
PNP OR NPN SELF CONFIGURING  
ENERGY SAVING

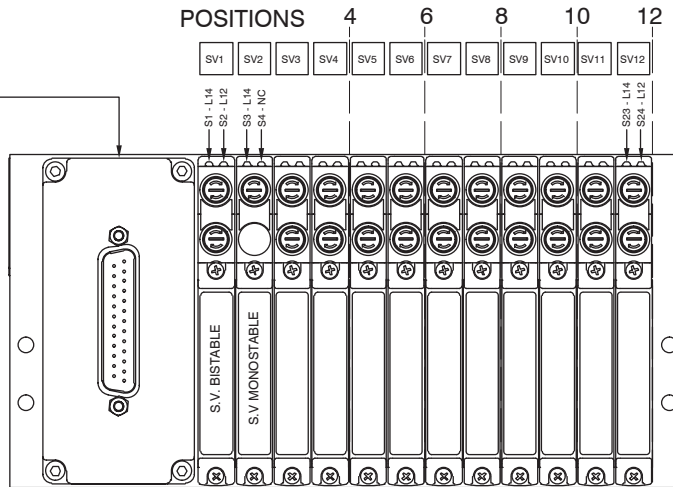
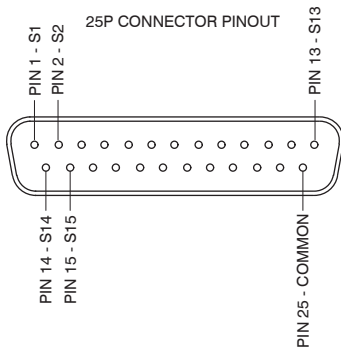

37 POLES MULTIPOINT MODULE  
16 SOLENOID VALVES  
PNP OR NPN SELF CONFIGURING  
ENERGY SAVING

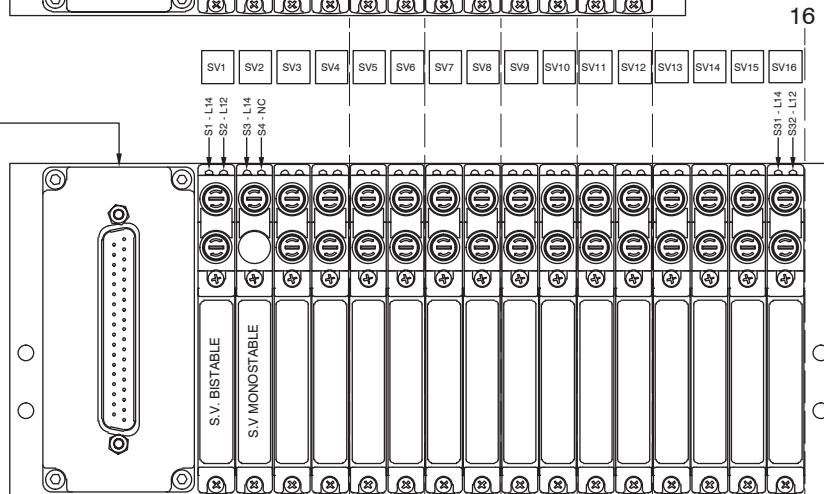
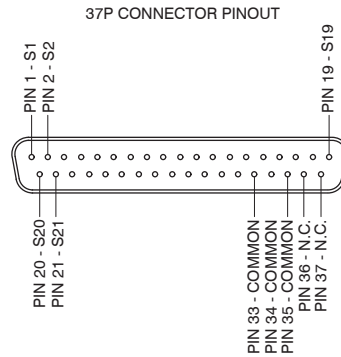

44 POLES MULTIPOINT MODULE  
20 SOLENOID VALVES  
PNP OR NPN SELF CONFIGURING  
ENERGY SAVING

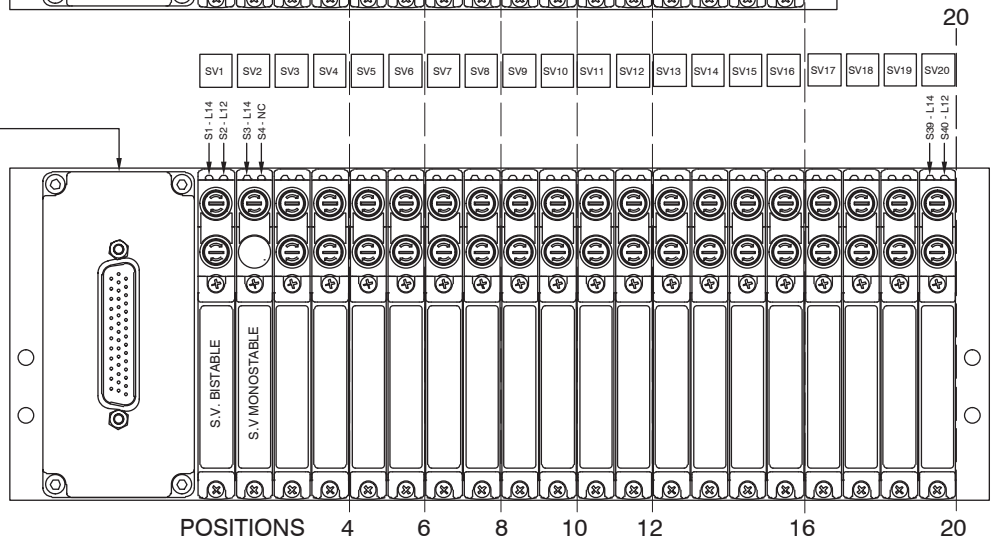
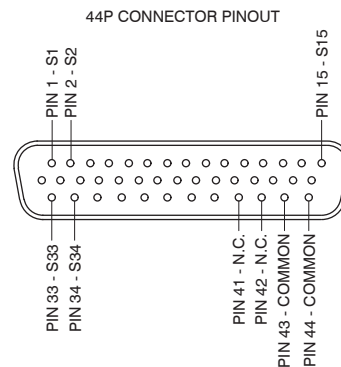

**DIN rail adapter**

Coding: 2300.16

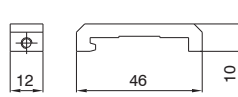

Weight 12 g

**Fitting M5 Ø6**

Coding: RDR560

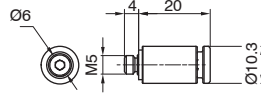

Weight 7 g

**Free valve space plug**

Coding: 3140.00

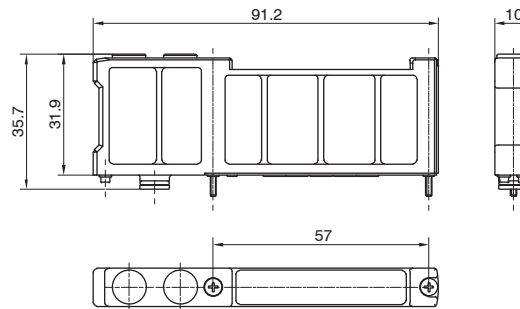

Weight 21 g

**Inlet/Exhaust module**

Coding: 3140.10

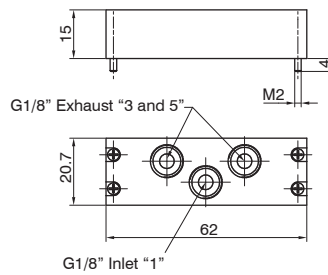

Weight 50 g

▶ Diaphragm plug

Coding: 3130.17



Weight 1,5 g

1 Diaphragm plug installation

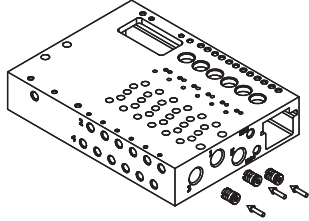

Diaphragm plug fixing

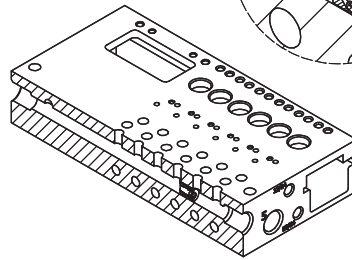
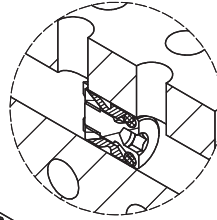
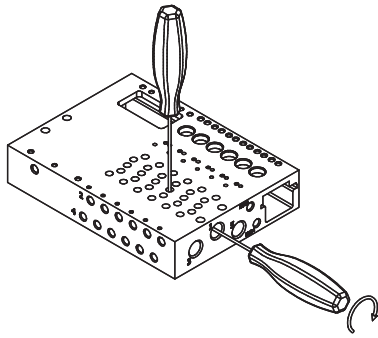

AIR DISTRIBUTION

▶ Cable complete with connector, 25 poles, IP65

Coding: 2300.25.L.C



	CABLE LENGTH
L	03=3 meters
	05=5 meters
	10=10 meters
	CONNECTORS
C	10=In line
	90=90° angle

▶ Cable complete with connector 37 poles, IP65

Coding: 2400.37.L.C



	CABLE LENGTH
L	03=3 meters
	05=5 meters
	10=10 meters
	CONNECTORS
C	10=In line
	90=90° angle

▶ Cable complete with connector 44 poles, IP65

Coding: 2300.44.L.C



	CABLE LENGTH
L	03=3 meters
	05=5 meters
	10=10 meters
	CONNECTORS
C	10=In line
	90=90° angle



Manifold

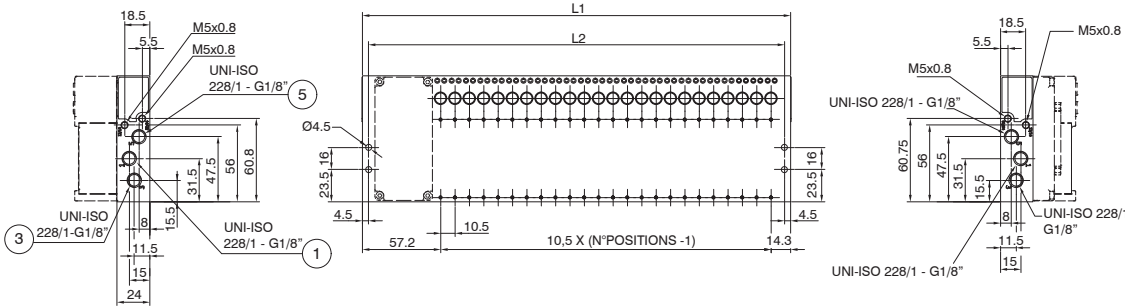
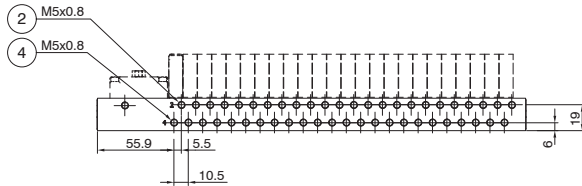

Coding: 3145.V.P

VERSION		
V	02 = External feeding	
	12 = Self feeding	
POSITIONS	L1	L2
04=4 Positions (weight 432 g)	103	94
06=6 Positions (weight 518 g)	124	115
08=8 Positions (weight 604 g)	145	136
P		
10=10 Positions (weight 690 g)	166	157
12=12 Positions (weight 776 g)	187	178
16=16 Positions (weight 948 g)	229	220
20=20 Positions (weight 1120 g)	271	262
24=24 Positions (weight 1280 g)	313	304

1  
AIR DISTRIBUTION

Manifold with accessories



1 = Inlet port G1/8"  
2 and 4 = Outlet port M5  
3 and 5 = Exhaust port G1/8"

Coding: 3145.V.P.A

VERSION		
V	02 = External feeding	
	12 = Self feeding	
POSITIONS	L1	L2
04=4 Positions (weight 432 g)	103	94
06=6 Positions (weight 518 g)	124	115
08=8 Positions (weight 604 g)	145	136
P		
10=10 Positions (weight 690 g)	166	157
12=12 Positions (weight 776 g)	187	178
16=16 Positions (weight 948 g)	229	220
20=20 Positions (weight 1120 g)	271	262
24=24 Positions (weight 1280 g)	313	304
ACCESSORIES		
A	01 = 1 optional position	
	02 = 2 optional positions	
	04 = 4 optional positions	
	08 = 8 optional positions	
	12 = 12 optional positions	

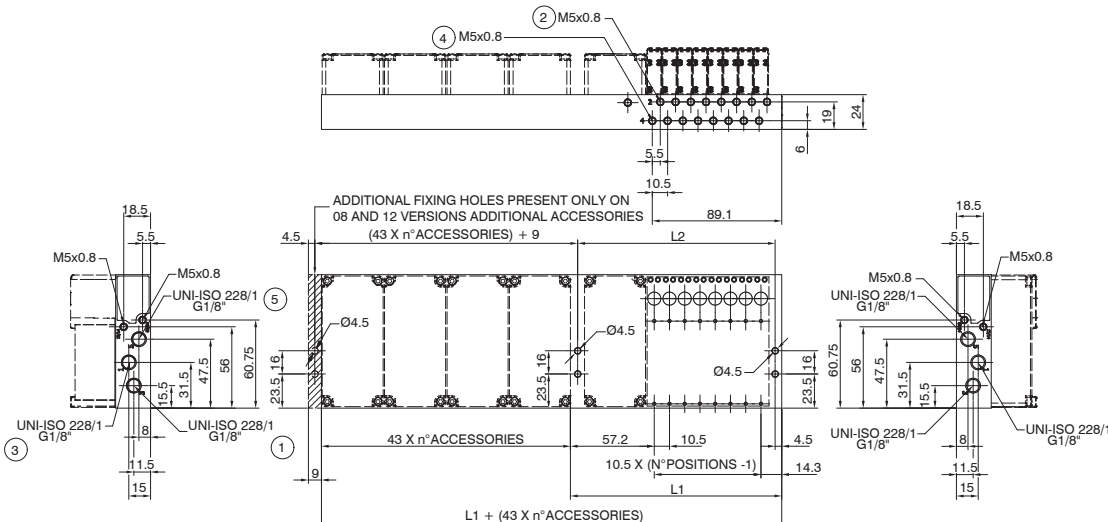

**Solenoid valve description**

PILOT STATE IDENTIFICATION LED L12  
(LED "ON" = IDENTIFIES ACTUATED PILOT)  
PILOT STATE IDENTIFICATION LED L14  
(LED "ON" = IDENTIFIES ACTUATED PILOT)

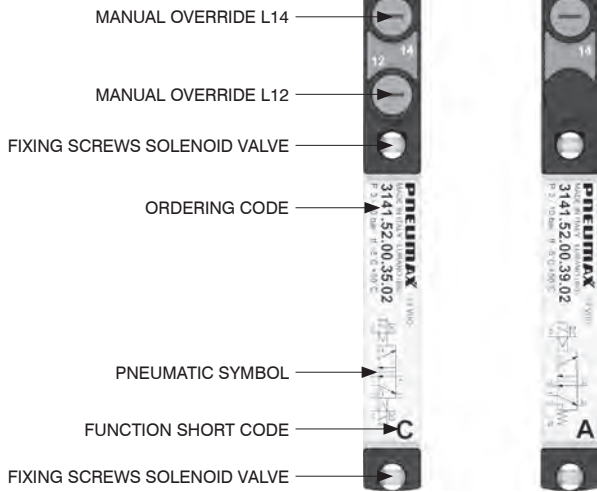

**From the top**

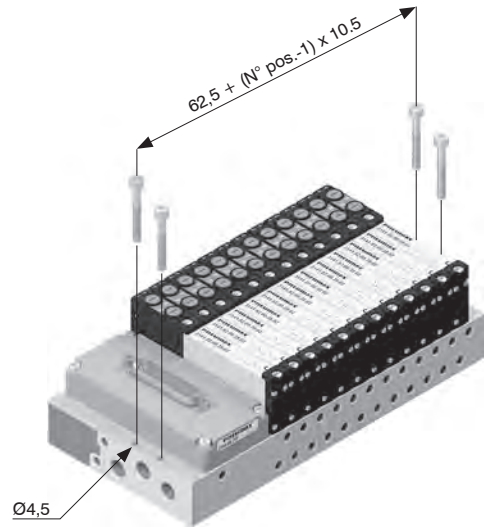

1  
AIR DISTRIBUTION

**DIN rail fixing**

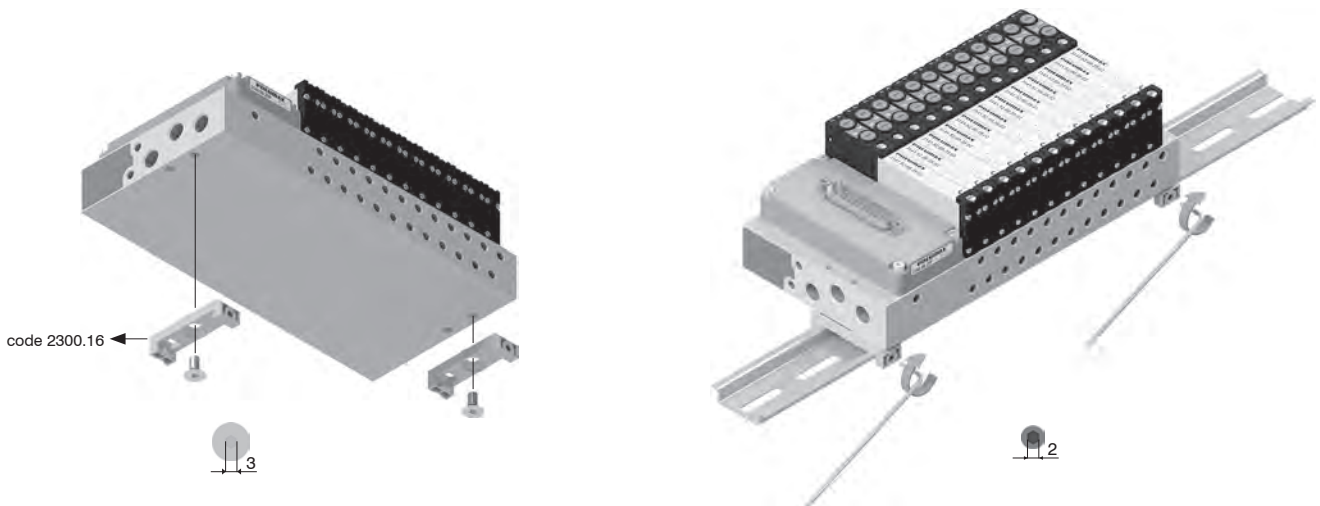

**Supply ports and maximum possible size according to valves used**

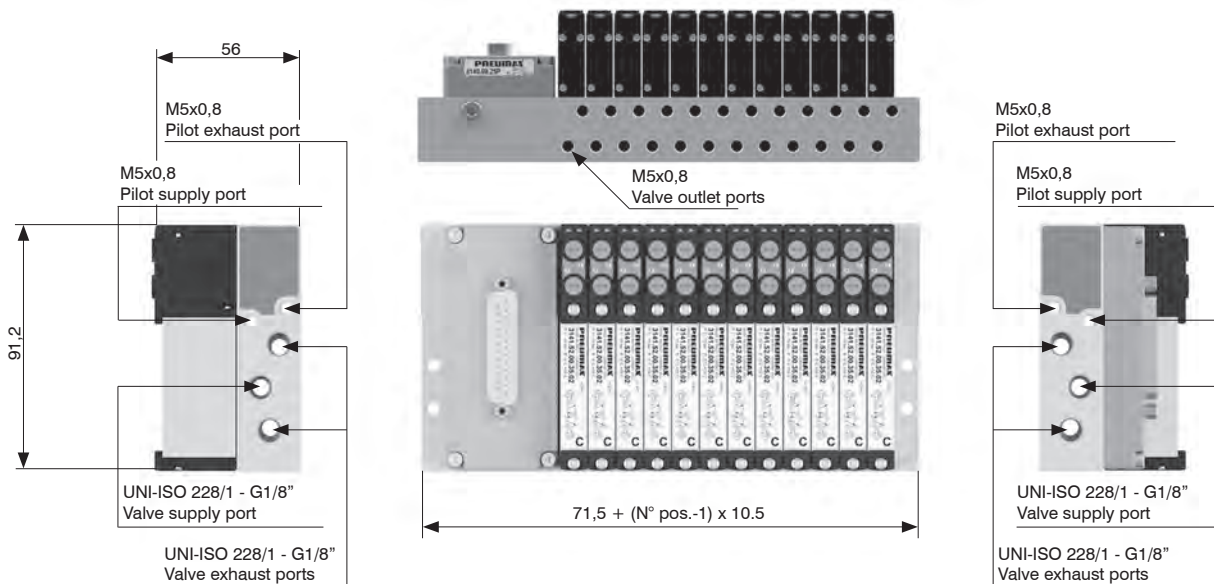



Manual override actuation



**Instable function:**  
Push to actuate  
(when released it moves back  
to the original position)

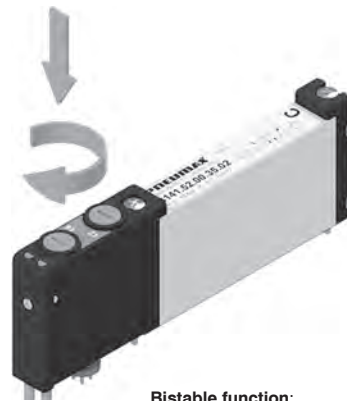

**Bistable function:**  
Push and turn to get the bistable  
function

**Note:** it is strongly suggested to replace the original position after using

Solenoid valves installation

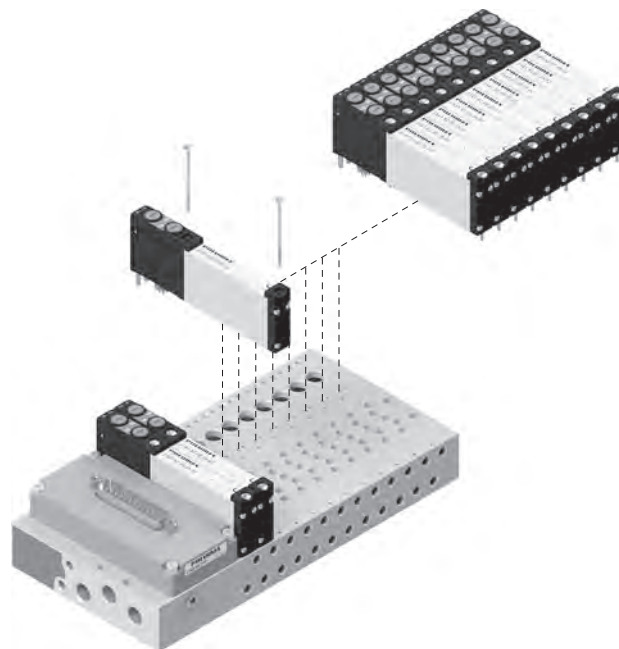

Max. torque moment: 0,2 Nm

Serial systems and multipoint system installation

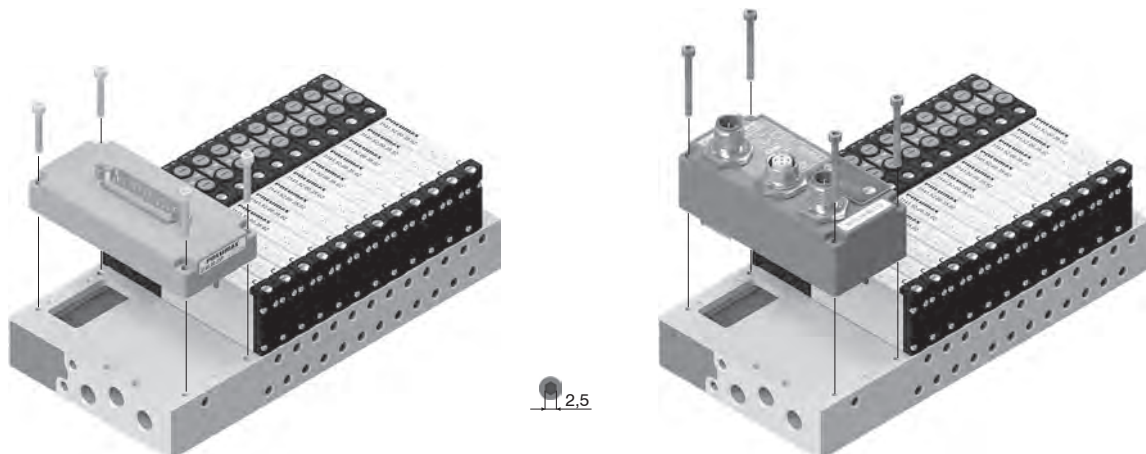

Max. torque moment: 0,5 Nm

**General - CANopen® slave modules**

CANopen® node handles up to 64 inputs and outputs, both divided into 8 bytes. Output typologies include solenoid valves, digital outputs (e.g. 5130.08.M8) and analog outputs (e.g. 5130.2T.00). Connectable inputs typologies include digital inputs modules (e.g. 5230.08.M8), analog input modules (e.g. 5230.2T.00), and Pt100 inputs modules (e.g. 5230.4P.02). Optional modules can be connected to the manifold in any order and configuration, provided that modules are installed starting from the node and optional position modules left to furthest end.

Electrical power must be supplied via circular M12 4 pins type A male connector. The separation between 24VDC supply of the node and 24VDC of the outputs allows to turn off outputs leaving the node and eventual inputs operational.

CANopen® network connection is achieved via two circular male-female M12 5 pins type A connectors connected in parallel; connectors pinout is compliant to CiA Draft Recommendation 303-1 (V. 1.3 : 30 December 2004).

Transmission speed and address are set via DIP-switch.

Internal termination resistance is on-board and can be enabled via DIP-switch as well.

There are two CANopen® node versions: they differ by number of outputs directly allocated to solenoid valve positions.

5530.64.32CO part number provides the first 32 out of 64 outputs, corresponding to less significant 4 bytes, are permanently allocated to solenoid valve positions, regardless how many they physically are and how many valves are installed. The remaining 32 outputs can be used to handle optional output modules. Bytes allocation to optional modules is done automatically.

5530.64.48CO part number provides the first 48 out of 64 outputs, corresponding to less significant 6 bytes, are permanently allocated to solenoid valve positions, regardless how many they physically are and how many valves are installed. The remaining 16 outputs can be used to handle optional output modules. Bytes allocation to optional modules is done automatically.

Two part-numbers have been provided to tailor configuration on your needs. 5530.64.48CO part number is recommended in case several solenoid valves must be handled, whilst ensuring room for future expansions.

5530.64.32CO part number is recommended in case increased flexibility is needed for digital outputs.

To better understand different possibilities offered during configuration, some examples follow.

**Ordering code**

**5530.64.32CO**

**5530.64.48CO**



1 AIR DISTRIBUTION

**Scheme / Overall dimensions and I/O layout**

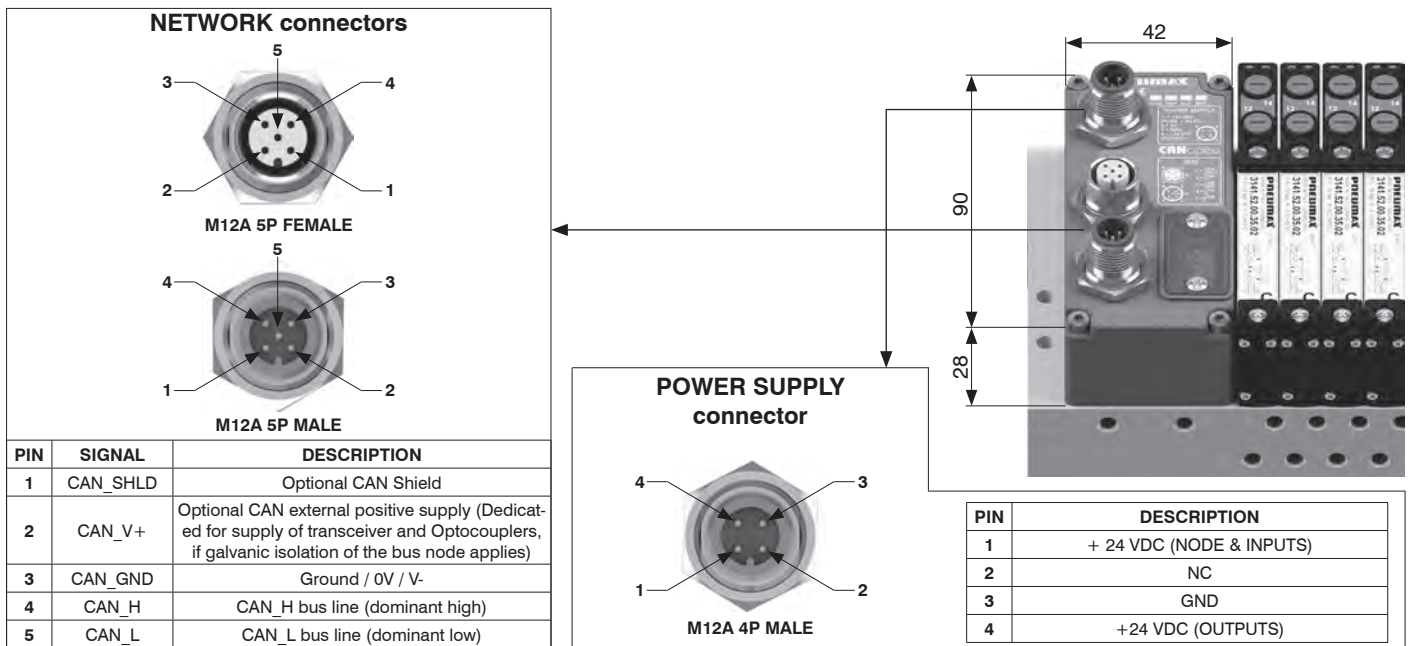

**Technical characteristics**

	Specifications	CiA Draft Standard Proposal 301 V 4.10 (15 August 2006)
	Case	Reinforced technopolymer
<b>Power supply</b>	Power supply connection	M12 4 P male connector (IEC 60947-5-2)
	Power supply voltage	+24 VDC +/- 10%
	Node consumption (without inputs)	30 mA
	Power supply diagnosis	Green LED PWR / Green LED OUT
<b>Network</b>	Network connectors	2 M12 5 P connectors male-female type A (IEC 60947-5-2)
	Baud rate	10 - 20 - 50 - 125 - 250 - 500 - 800 - 1000 Kbit/s
	Addresses possible numbers	From 1 to 63
	Max. node in net	64 (slave + master)
	Bus maximum recommended length	100 m at 500 Kbit/s
	Bus diagnosis	Green LED + red LED
	Configuration file	Available from our web site <a href="http://www.pneumaxspa.com">http://www.pneumaxspa.com</a>
	IP Rating	IP65 when assembled
	Temperature range	From 0°C to +50°C



**General - PROFIBUS DP slave modules**

PROFIBUS DP node handles up to 64 inputs and outputs, both divided into 8 bytes. Output typologies include solenoid valves, digital outputs (e.g. 5130.08.M8) and analog outputs (e.g. 5130.2T.00). Connectable inputs typologies include digital inputs modules (e.g. 5230.08.M8), analog input modules (e.g. 5230.2T.00), and Pt100 inputs modules (e.g. 5230.4P02). Optional modules can be connected to the manifold in any order and configuration, provided that modules are installed starting from the node and optional position modules left to furthest end. Electrical power must be supplied via circular M12 4 pins type A male connector. The separation between 24VDC supply of the node and 24VDC of the outputs allows to turn off outputs leaving the node and eventual inputs operational.

PROFIBUS DP network connection is achieved via two circular male-female M12 5 pins type B connectors, connected in parallel; connector pinout is PROFIBUS Interconnection Technology compliant (Version 1.1 August 2001). Network node address is set via DIP-switch.

Internal termination resistance is on-board and can be enabled via DIP-switch as well.

There are two PROFIBUS DP node versions: they differ by number of outputs directly allocated to solenoid valve positions.

5330.64.32PB part number provides the first 32 out of 64 outputs, corresponding to less significant 4 bytes, are permanently allocated to solenoid valve positions, regardless how many they physically are and how many valves are installed. The remaining 32 outputs can be used to handle optional output modules. Bytes allocation to optional modules is done automatically.

5330.64.48PB part number provides the first 48 out of 64 outputs, corresponding to less significant 6 bytes, are permanently allocated to solenoid valve positions, regardless how many they physically are and how many valves are installed. The remaining 16 outputs can be used to handle optional output modules. Bytes allocation to optional modules is done automatically.

Two part-numbers have been provided to tailor configuration on your needs. 5330.64.48PB part number is recommended in case several solenoid valves must be handled, whilst ensuring room for future expansions. 5330.64.32PB part number is recommended in case increased flexibility is needed for digital outputs.

To better understand different possibilities offered, some configuration examples are made in the following pages.

**Ordering code**

- 5330.64.32PB
- 5330.64.48PB



1  
AIR DISTRIBUTION

**Scheme / Overall dimensions and I/O layout**

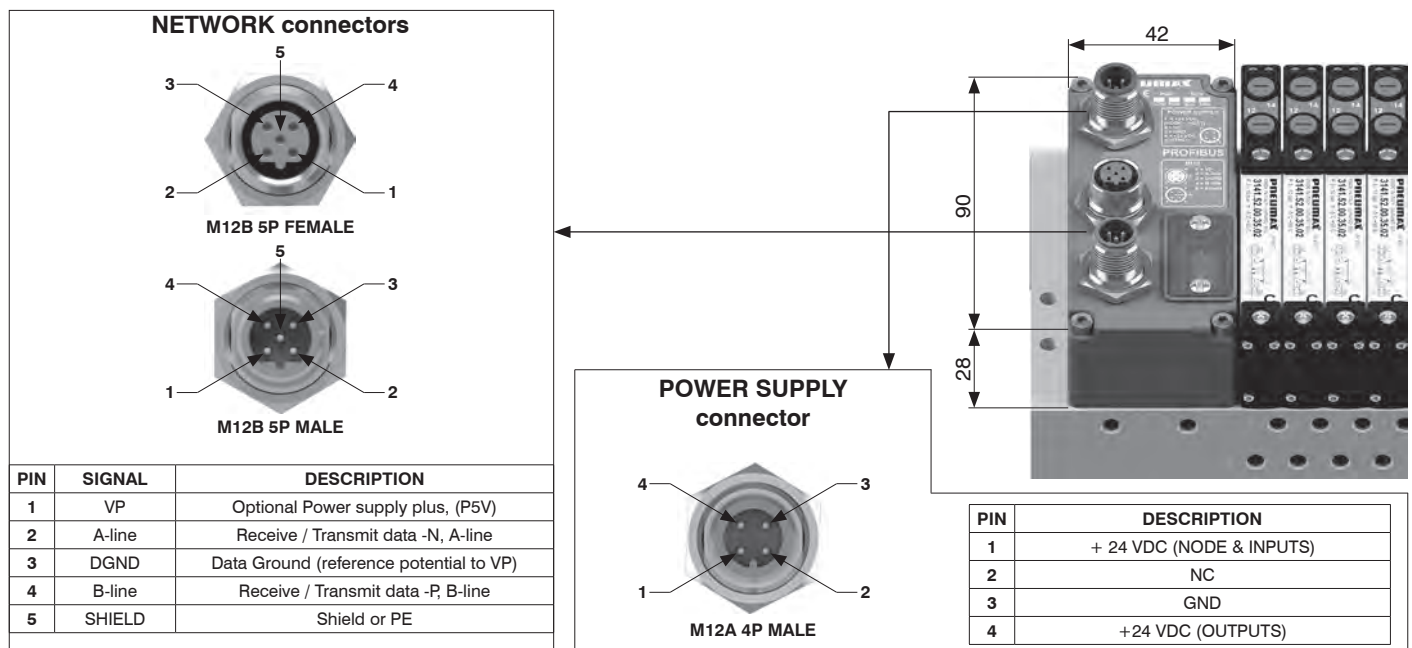

**Technical characteristics**

	Specifications	PROFIBUS DP
	Case	Reinforced technopolymer
<b>Power supply</b>	Power supply connection	M12 4 P male connector (IEC 60947-5-2)
	Power supply voltage	+24 VDC +/- 10%
	Node consumption (without inputs)	50 mA
	Power supply diagnosis	Green LED PWR / Green LED OUT
<b>Network</b>	Network connectors	2 M12 5 P connectors male-female type B
	Baud rate	9,6 - 19,2 - 93,75 - 187,5 - 500 - 1500 - 3000 - 6000 - 12000 Kbit/s
	Addresses possible numbers	From 1 to 99
	Max. node in net	100 (slave + master)
	Bus maximum recommended length	100 m at 12 Mbit/s - 1200 m at 9,6 Kbit/s
	Bus diagnosis	Green LED + red LED
	Configuration file	Available from our web site <a href="http://www.pneumaxspa.com">http://www.pneumaxspa.com</a>
	IP Rating	IP65 when assembled
Temperature range	From 0°C to +50°C	

**General - EtherNet/IP - EtherCAT® - PROFINET IO RT slave modules**

5730.128.48PN, 5730.128.48EC e 5730.128.48EI nodes handle up to 128 inputs and outputs, both divided into 16 bytes. Output typologies include solenoid valves, digital outputs (e.g. 5130.08.M8) and analog outputs (e.g. 5130.2T.00). Connectable input types include digital inputs modules (e.g. 5230.08.M8), analog inputs modules (e.g. 5230.2T.00) and Pt100 inputs modules (e.g. 5230.4P.02). Optional modules can be connected to the manifold in any order and configuration, provided that modules are installed starting from the node and optional position modules left to furthest end.

Electric power must be supplied via circular M12 4 pins male type A connector. The separation between 24VDC supply of the node and 24VDC of the outputs allows to turn off outputs leaving the node and eventual inputs operational.

The network connection is achieved via two circular female connectors (M12 4 pins, type D); these two circular connectors belong to two separate communication ports; hence they are not connected in parallel.

In 5730.128.48PN, 5730.128.48EC and 5730.128.48EI part numbers the first 48 out of 128 outputs, corresponding to less significant 6 bytes, are permanently allocated to the solenoid valve positions, regardless how many they are and how many valves are installed. The remaining 80 outputs can be used to handle optional output modules. Bytes allocation to optional modules is done automatically.

When more than 64 inputs are needed and current coming from 24VDC rail is higher than 2.5A, the use of additional power supply module (part number 5030.M12) is mandatory. 5030.M12 additional power supply module must be plugged-in upstream to the modules exceeding the above stated current limit, therefore close to the network node. On the other hand, whenever 64 outputs are used and further optional outputs modules are required, if total computed simultaneous current is higher than 2A, the 5030.M12 module is mandatory. 5030.M12 module is plugged-in upstream to additional modules; it will supply electrical power to downstream modules. If 5030.M12 module has been already integrated to supply inputs modules, it is not necessary to install a second one, since it already supplies outputs modules.

**Ordering code**

- 5730.128.48EI**
- 5730.128.48EC**
- 5730.128.48PN**



**Scheme / Overall dimensions and I/O layout**

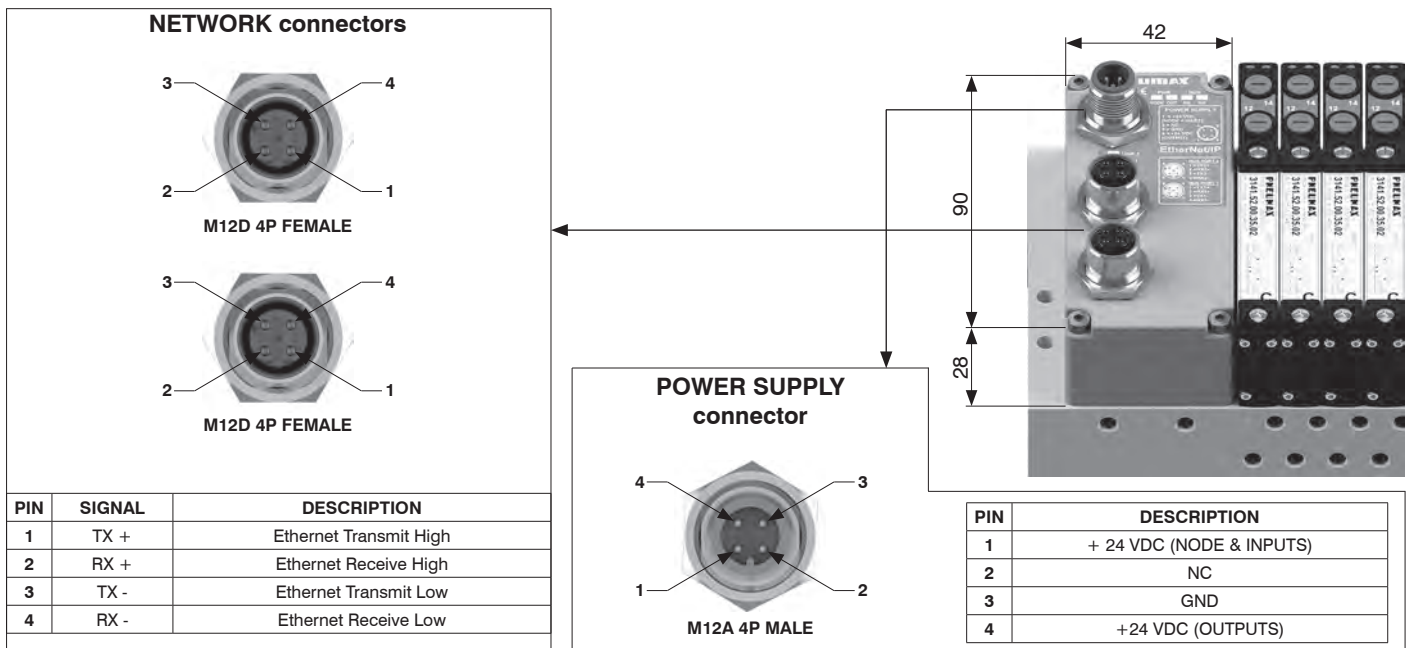

**Technical characteristics**

<b>Power supply</b>	Case	Reinforced technopolymer
	Power supply connection	M12 4 P male connector (IEC 60947-5-2)
	Power supply voltage	+24 VDC +/- 10%
	Node consumption (without inputs)	100 mA
<b>Network</b>	Power supply diagnosis	Green LED PWR / Green LED OUT
	Network connectors	2 M12 4 P female connectors type D (IEC 61076-2-101)
	Baud rate	100 Mbit/s
	Addresses possible numbers	As an IP address
	Maximum distance between 2 nodes	100 m
	Bus diagnosis	2 bicolor red / green LEDs + 4 LEDs for link & activity
	Configuration file	Available from our web site <a href="http://www.pneumaxspa.com">http://www.pneumaxspa.com</a>
	IP Rating	IP65 when assembled
Temperature range	From 0°C to +50°C	



**General - IO-Link slave modules**

IO-Link node handles up to 64 inputs and outputs, both divided into 8 bytes. Output typologies include solenoid valves, digital outputs (e.g. 5130.08.M8) and analog outputs (e.g. 5130.2T.00). Connectable inputs typologies include digital inputs modules (e.g. 5230.08.M8), analog input modules (e.g. 5230.2T.00), and Pt100 inputs modules (e.g. 5230.4P02). Optional modules can be connected to the manifold in any order and configuration, provided that modules are installed starting from the node and optional position modules left to furthest end.

Electrical power and connection to IO-Link Master come through male circular connector M12, 5 poles, type A, "CLASS B" according to IO-Link specifications. L+/L- electrical power allows to supply the node while P24/N24 electrical power allows to supply inputs and outputs modules, including solenoid valves, connected to the manifold. L+/L- and P24/N24 power supplies are galvanically isolated into the IO-Link node.

IO-Link node exists in two versions: they differ by number of outputs directly allocated to solenoid valve positions. 5830.64.32IK part number provides the first 32 out of 64 outputs, corresponding to less significant 4 bytes, are permanently allocated to solenoid valve positions, regardless how many they physically are and how many valves are installed. The remaining 32 outputs can be used to handle optional output modules. Bytes allocation to optional modules is done automatically.

5830.64.48IK part number provides the first 48 out of 64 outputs, corresponding to less significant 6 bytes, are permanently allocated to solenoid valve positions, regardless how many they physically are and how many valves are installed. The remaining 16 outputs can be used to handle optional output modules. Bytes allocation to optional modules is done automatically.

Two part-numbers have been provided to tailor configuration on your needs. 5830.64.48IK part number is recommended in case several solenoid valves must be handled, whilst ensuring room for future expansions. 5830.64.32IK part number is recommended in case increased flexibility is needed for digital outputs.

**Ordering code**

5830.64.32IK  
5830.64.48IK



1  
AIR DISTRIBUTION

**Scheme / Overall dimensions and I/O layout**

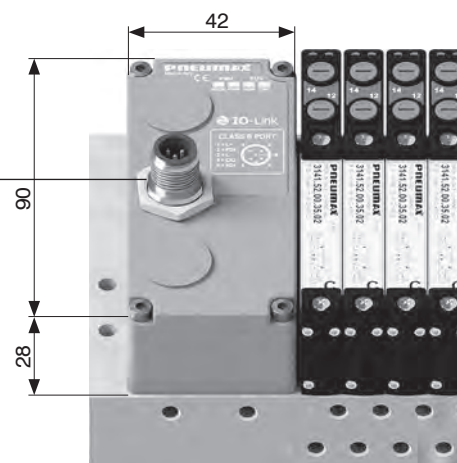
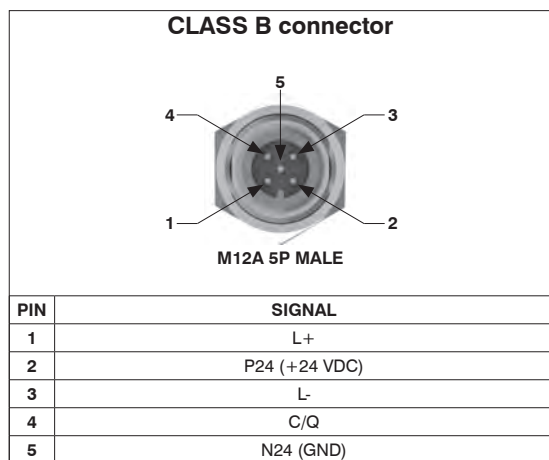

**Technical characteristics**

	Specifications	IO-Link Specification v1.1
	Case	Reinforced technopolymer
<b>Outputs</b>	PNP equivalent outputs	+24 VDC +/- 10%
	Maximum output number	64
	Maximum output simultaneously actuated	64
<b>Network</b>	Network connectors	Class B port
	Communication speed	COM2
	Maximum distance from Master	20 m
	Bus diagnosis	1 green and 1 red LED di stato for status
	Vendor ID / Device ID	1257 (hex 0x04E9) / 3000 (hex 0x0BB8)
	Configurations file IODD	Available from our web site <a href="http://www.pneumaxspa.com">http://www.pneumaxspa.com</a>
	IP Rating	IP65 when assembled
	Temperature range	From 0°C to +50°C

**General - 8 M8 digital inputs module**

M8 digital inputs module provides 8 M8, 3 pins, female connectors. Inputs have PNP logic, 24VDC ± 10%.

It is possible to connect 2 wires devices (e.g. switches, magnetic limit switches, pressure switches, etc...) as well as 3 wires devices (e.g. proximity sensors, photocells, electronic magnetic limit switches, etc.).

Inputs module power supply is provided by 24VDC power input on the serial system (type A, 4 pin M12 power connector, pin 1) or by module 5030.M12, in case it were installed upstream of the inputs module.

Maximum overall available current for all 8 inputs on 24VDC rail is 300mA, since every module is equipped with an auto-resettable fuse with 300mA threshold, thus, in case of overload or short circuit, 24VDC rail is interrupted and, as a consequence, all 8 inputs 24VDC is turned off along with green PWR LED. Other eventually connected inputs modules stays operational. Removing fault cause, green PWR LED gets back in on status and module becomes operational again.

The M8 digital inputs module takes up 8 input bits of the serial node installed on the manifold.

**Ordering code**

**5230.08.M8**



**Scheme / Overall dimensions and I/O layout**

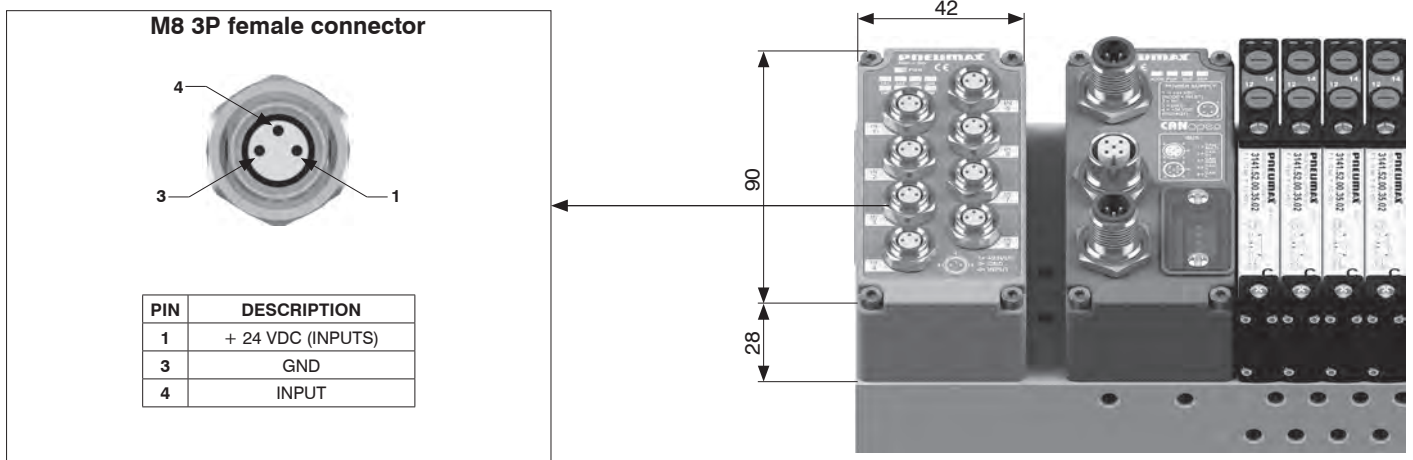

**General - 8 M12 digital inputs module**

M12 digital inputs module provides 4 M12, 5 pins, female connectors. Inputs have PNP logic, 24VDC ± 10%.

Every connector takes two independent input channels.

It is possible to connect 2 wires devices (e.g. switches, magnetic limit switches, pressure switches, etc...) as well as 3 wires devices (e.g. proximity sensors, photocells, electronic magnetic limit switches, etc.).

Inputs module power supply is provided by 24VDC power input on the serial system (type A, 4 pin M12 power connector, pin 1) or by module 5030.M12, in case it were installed upstream of the inputs module.

Maximum overall available current for all 4 connectors on 24VDC rail is 300mA, since every module is equipped with an auto-resettable fuse with 300mA threshold, thus, in case of overload or short circuit, 24VDC rail is interrupted and as a consequence all inputs 24VDC is turned off along with green PWR LED. Other eventually connected inputs modules remains operational. Removing fault cause, green PWR LED gets back in on status and module becomes operational again.

The M12 digital inputs module takes up 8 input bits of the serial node installed on the manifold.

**Ordering code**

**5230.08.M12**



**Scheme / Overall dimensions and I/O layout**

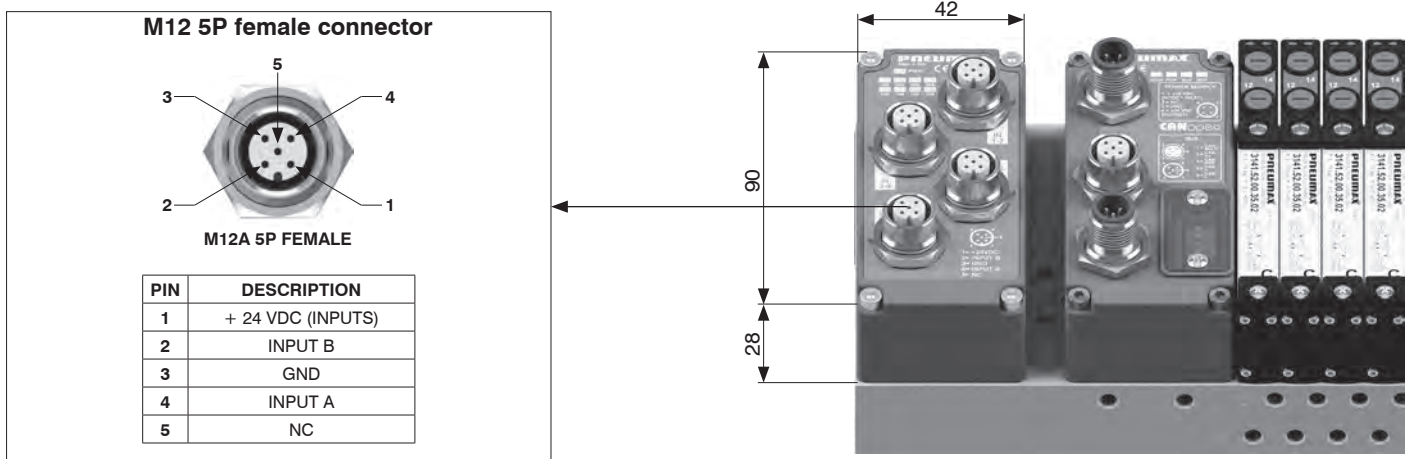



**General - 8 M8 digital outputs module**

Module has 8 M8 female connectors.

Outputs have PNP logic, 24VDC ± 10%.

Maximum available current per output is 100mA.

Electric power on outputs module is supplied by pin 4 of the M12 power connector on the network node or by the expansion module (5030.M12 part number). Power supply presence is displayed by "PWR OUT" green LED light-on. The module takes up 8 outputs (8 bits of the output bytes) of the serial node.

**Ordering code**

5130.08.M8



**Scheme / Overall dimensions and I/O layout**

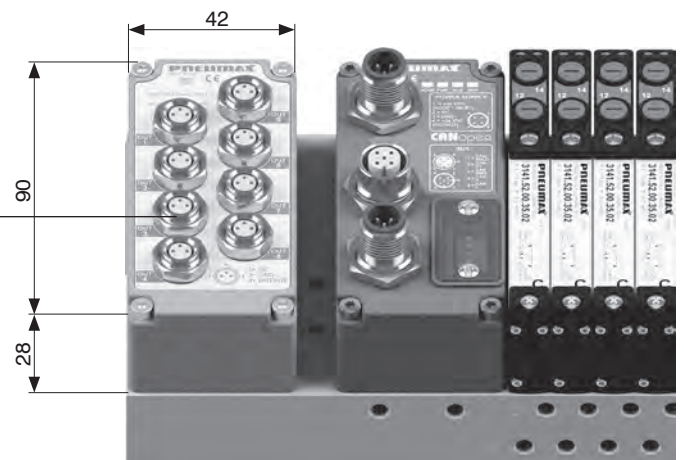
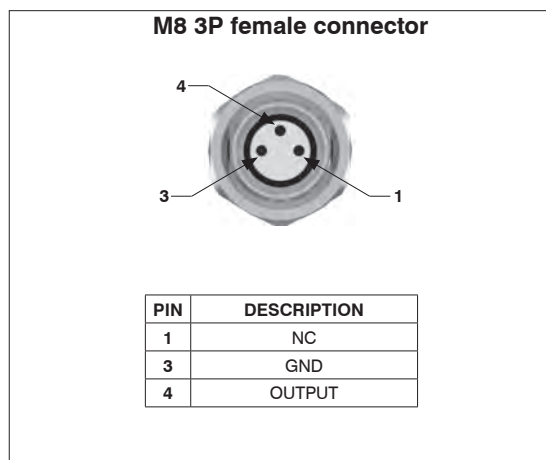

1  
AIR DISTRIBUTION

**General - 8 M12 digital outputs module**

Module has 4 M12 female connectors.

Outputs have PNP logic, 24VDC ± 10%.

Maximum available current per output is 100mA.

Electric power on outputs module is supplied by pin 4 of the M12 power connector on the network node or by the expansion module (5030.M12 part number). Power supply presence is displayed by "PWR OUT" green LED light-on. The module takes up 8 outputs (8 bits of the output bytes) of the serial node.

**Ordering code**

5130.08.M12



**Scheme / Overall dimensions and I/O layout**

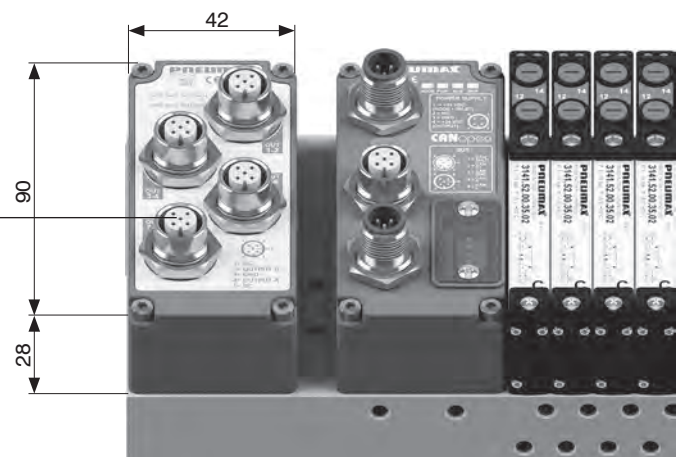
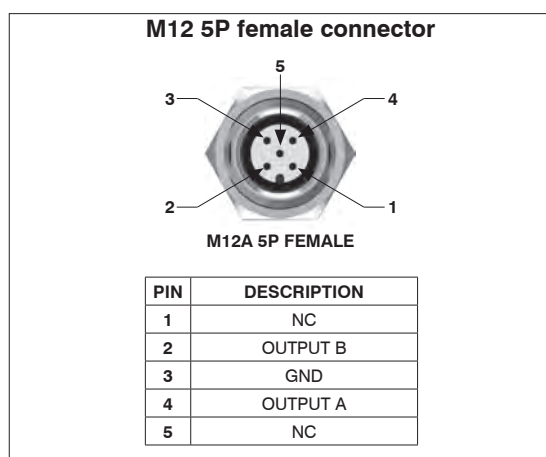

1 AIR DISTRIBUTION

**General - 32 digital inputs SUB-D 37 pins module**

The module provides a SUB-D 37 pins female connector.

Inputs have PNP logic, 24VDC  $\pm$  10%.

It is possible to connect 2 wires devices (e.g. switches, magnetic limit switches, pressure switches, etc...) as well as 3 wires devices (e.g. proximity sensors, photocells, electronic magnetic limit switches, etc.).

Inputs module power supply is provided by 24VDC power input on the serial system (type A, 4 pin M12 power connector, pin 1) or by module 5030.M12, in case it were installed upstream of the inputs module.

Maximum overall available current for all 32 inputs on 24VDC rail is 1A, since every module is equipped with an auto-resettable fuse with 1A threshold, thus, in case of overload or short circuit, 24VDC rail is interrupted and as a consequence all 32 inputs 24VDC is turned off along with green PWR LED. Other eventually connected inputs modules stays operational. Removing fault cause, green PWR LED gets back in on status and module becomes operational again.

The module takes up 32 bits on the input data of the serial node installed.

**Ordering code**

**5230.32.37P**



**Scheme / Overall dimensions and I/O layout**

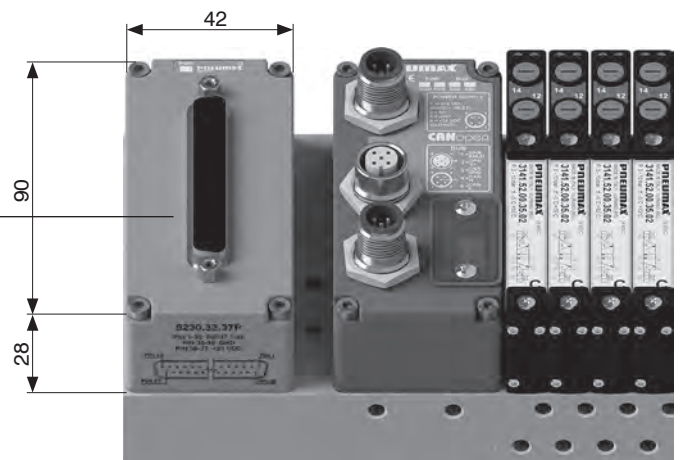
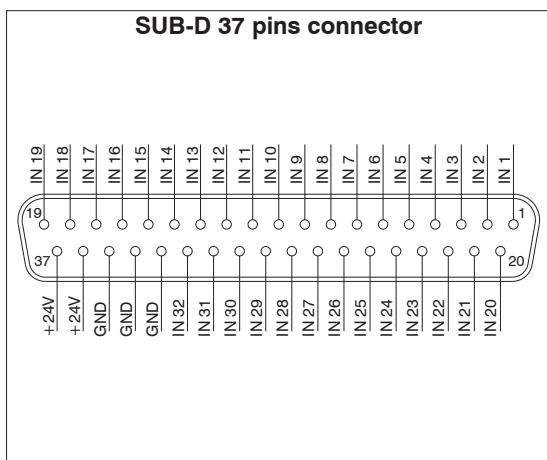

**General - 32 digital outputs SUB-D 37 pins module**

Module has a SUB-D 37 pins female connector.

Outputs have PNP logic, 24VDC  $\pm$  10%.

Maximum available current per output is 100mA.

Electric power on outputs module is supplied by pin 4 of the M12 power connector on the network node or by the expansion module (5030.M12 part number). Power supply presence is displayed by "PWR OUT" green LED light-on.

The module takes up 32 outputs (32 bits of the output bytes) of the serial node.

**Ordering code**

**5130.32.37P**



**Scheme / Overall dimensions and I/O layout**

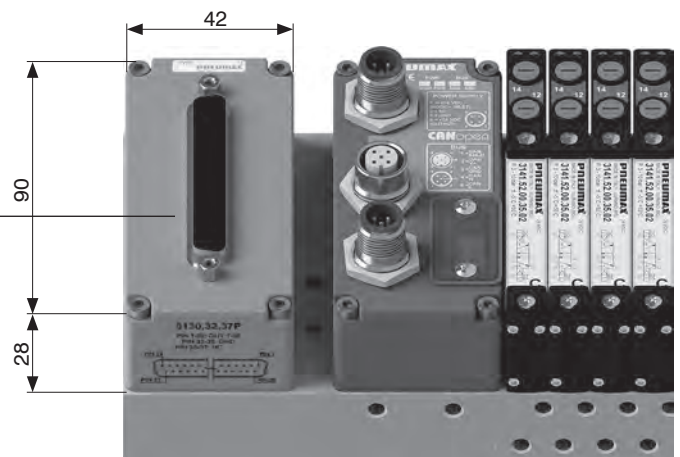
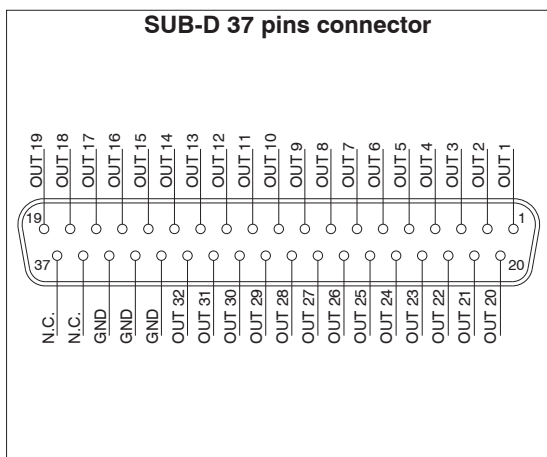





**General - M8 analogue inputs modules**

M8 analog inputs module digitizes analog signals and transfer acquired data to field bus, via network node. Each input is sampled at 12 bits and transmitted, for convenience, at 16 bit, whose less significant bits padded to 0. Therefore, each digitized signal takes 16 inputs (2 bytes) of the serial node. During the ordering process, it is necessary to verify that the serial node has enough free inputs. Following table reports available models:

CODE	SIGNAL	ANALOGUE INPUTS	MAXIMUM CURRENT ON +24 VDC RAIL	OCCUPIED INPUTS
5230.2T.00	VOLTAGE 0-10V	2	300 mA	32 (4 Byte)
5230.2T.01	VOLTAGE 0-5V	2	300 mA	32 (4 Byte)
5230.4T.00	VOLTAGE 0-10V	4	750 mA	64 (8 Byte)
5230.4T.01	VOLTAGE 0-5V	4	750 mA	64 (8 Byte)
5230.2C.00	CURRENT 4-20mA	2	300 mA	32 (4 Byte)
5230.2C.01	CURRENT 0-20mA	2	300 mA	32 (4 Byte)
5230.4C.00	CURRENT 4-20mA	4	750 mA	64 (8 Byte)
5230.4C.01	CURRENT 0-20mA	4	750 mA	64 (8 Byte)

Power supply of the M8 analog inputs module is provided by 24VDC power input on the serial system (type A, 4 pin M12 power connector, pin 1) or by module 5030.M12, in case it were installed upstream of the inputs module. Modules provide M8 3 pins female connectors and a diagnostic LED for every analog input. The LED indicates signal presence (green) or signal out of range (red). Maximum available current for each channel on 24VDC rail (pin 1) is reported in the table. Each module provides an internal resettable fuse, which cuts 24VDC power supply to every M8 connector and turning off green PWR LED when thresholds are exceeded. Inputs of other eventual modules connected to the node continue to operate uninterrupted. By removing the cause of the threshold overrun, green PWR LED gets back in ON status and the module becomes operational again.

**Ordering code**

5230. \_\_ \_ 0 \_



1  
AIR DISTRIBUTION

**Scheme / Overall dimensions and I/O layout**

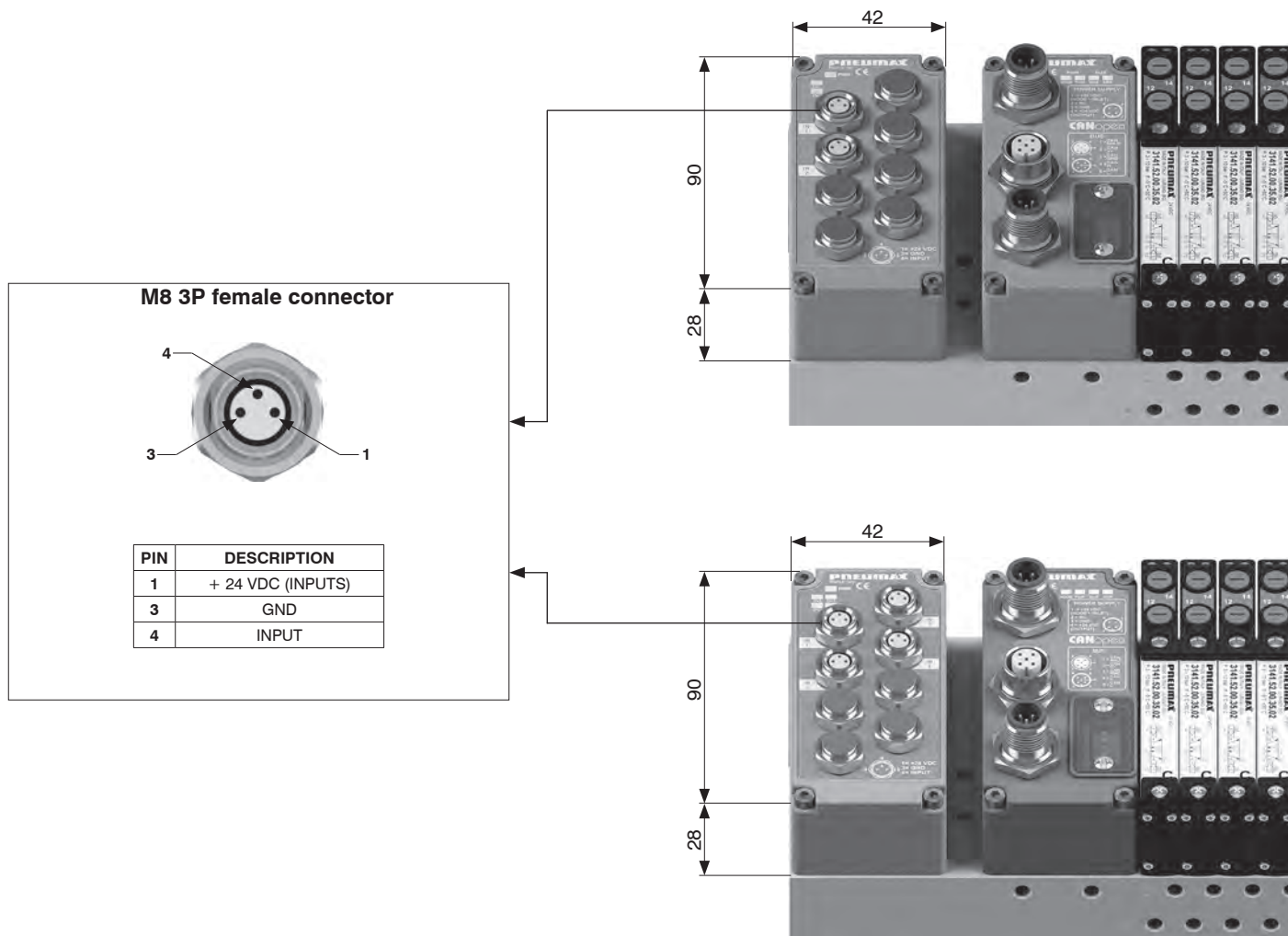

**General - M8 analogue outputs modules**

M8 analog outputs module converts output data, received from field bus via network node, into analog signal. Each analog output has a resolution of 12 bits, processed from 16 outputs (2 bytes), ignoring 4 less significant bits. During the ordering process, it is necessary to verify that the serial node has enough free outputs. Different models are available:

**Ordering code**

5130.\_.\_0\_



1 AIR DISTRIBUTION

CODE	SIGNAL	ANALOGUE OUTPUTS	MAXIMUM CURRENT ON + 24 VDC RAIL	OCCUPIED OUTPUTS
5130.2T.00	VOLTAGE 0-10V	2	1 A	32 (4 Byte)
5130.2T.01	VOLTAGE 0-5V	2	1 A	32 (4 Byte)
5130.4T.00	VOLTAGE 0-10V	4	2 A (1A for each pair of channel)	64 (8 Byte)
5130.4T.01	VOLTAGE 0-5V	4	2 A (1A for each pair of channel)	64 (8 Byte)
5130.2C.00	CURRENT 4-20mA	2	1 A	32 (4 Byte)
5130.2C.01	CURRENT 0-20mA	2	1 A	32 (4 Byte)
5130.4C.00	CURRENT 4-20mA	4	2 A (1A for each pair of channel)	64 (8 Byte)
5130.4C.01	CURRENT 0-20mA	4	2 A (1A for each pair of channel)	64 (8 Byte)

Power supply of the M8 analog outputs module is provided by 24VDC power input on the serial system (type A, 4 pin M12 power connector, pin 4) or by module 5030.M12, in case it were installed upstream of the outputs module. Modules provide M8 3 pins female connectors and a diagnostic LED for every analog input. The LED indicates signal presence (green) or overload fault (red). Maximum available current for each channel on 24VDC rail (pin 1) is reported in the table. Each module provides an internal resettable fuse, which cuts 24VDC power supply to every M8 connector and turning off green PWR LED when thresholds are exceeded. Outputs of other eventual modules connected to the node continue to operate uninterrupted. By removing the cause of the threshold overrun, green PWR LED gets back in ON status and the module becomes operational again.

**Scheme / Overall dimensions and I/O layout**

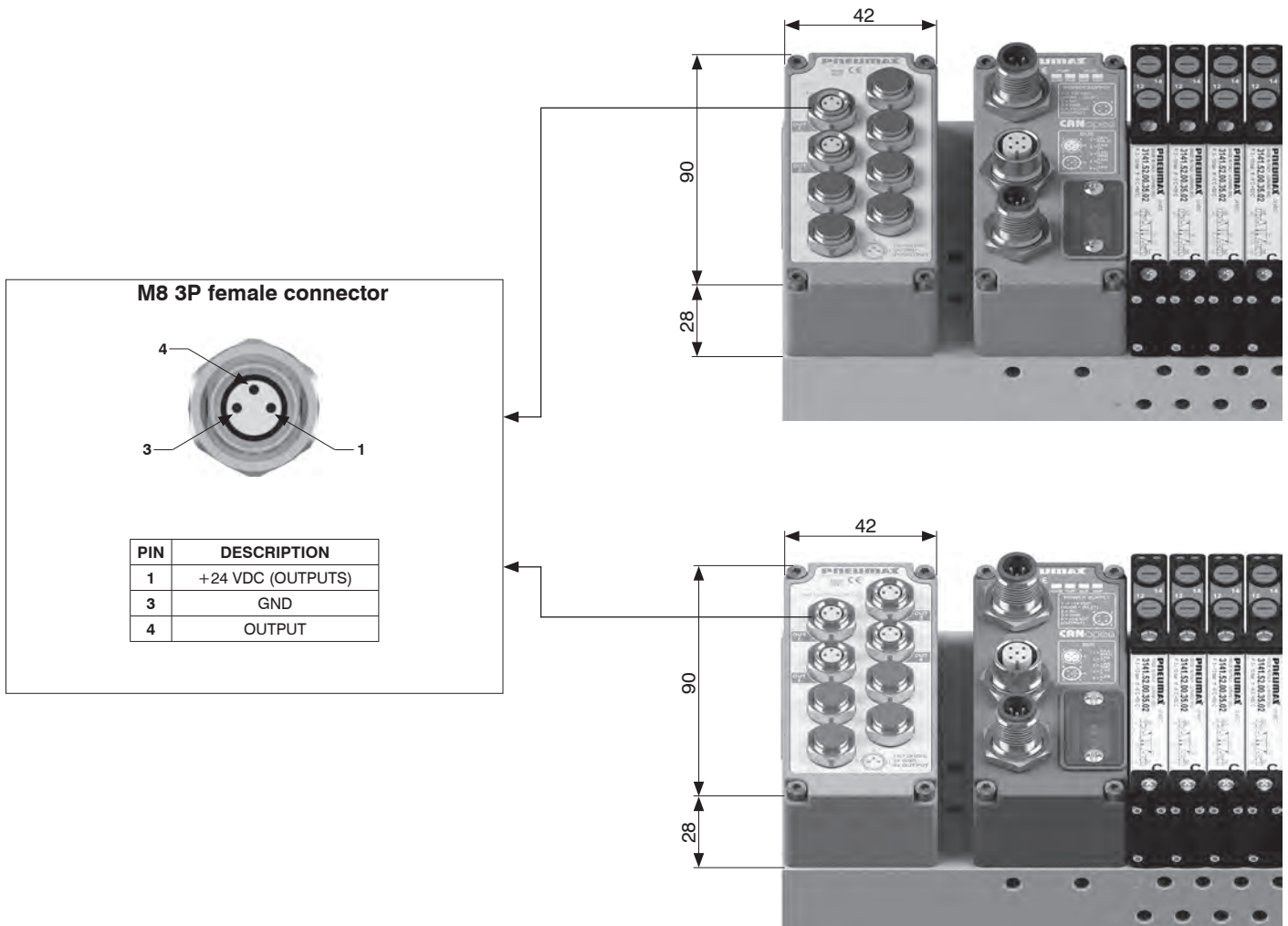



**General - Pt100 inputs modules**

Pt100 inputs module digitizes signals from Pt100 sensors and transfers acquired data to field bus, via network node. Each input is sampled at 12 bits and transmitted, for convenience, at 16 bits, whose less significant bits padded to 0. Therefore, each digitized signal takes 16 inputs (2 bytes) of the serial node. During the ordering process, it is necessary to verify that the serial node has enough free inputs.

It is possible to connect two, three or four wire sensors.  
Temperature range is from -100°C to 300°C.  
When sensor is not connected, it is returned a value corresponding to -100°C.

Temperature can be obtained from node read value (in points) using this formula:

$$\text{Temperature (}^\circ\text{C)} = \left( \frac{\text{Points} \times 400}{4095} \right) - 100$$

Following table reports available models:

CODE	MODEL	INPUTS NUMBER	OCCUPIED INPUTS
5230.2P00	Pt100 2 wires	2	32 (4 Byte)
5230.2P01	Pt100 3 wires	2	32 (4 Byte)
5230.2P02	Pt100 4 wires	2	32 (4 Byte)
5230.4P00	Pt100 2 wires	4	64 (8 Byte)
5230.4P01	Pt100 3 wires	4	64 (8 Byte)
5230.4P02	Pt100 4 wires	4	64 (8 Byte)

Module provides M8 4 pins female connectors and a diagnostic LED for every input.  
The LED indicates the presence of the PT100 sensor or the overcoming of set temperature threshold.

Inputs module power supply is provided by 24VDC power input on the serial system (type A, 4 pin M12 power connector, pin 1) or by module 5030.M12, in case it were installed upstream of the inputs module.  
Presence of power supply +24VDC is indicated by a PWR green LED.

**Ordering code**

5230. \_\_ \_ 0



1  
AIR DISTRIBUTION

**Scheme / Overall dimensions and I/O layout**

**M8 4P female connector**

**Connection scheme 2 wires probe**

PIN	DESCRIPTION
1	NC
2	SENSOR +
3	POWER SUPPLY -
4	NC

**Connection scheme 3 wires probe**

PIN	DESCRIPTION
1	POWER SUPPLY -
2	SENSOR +
3	POWER SUPPLY -
4	NC

**Connection scheme 4 wires probe**

PIN	DESCRIPTION
1	POWER SUPPLY +
2	SENSOR +
3	POWER SUPPLY -
4	SENSORE -

**General - Additional power supply module**

Additional power supply module 5030.M12 supplies additional electric power for downstream optional modules, where "downstream" means farther from serial node.

Electric connection of the module to external power supply unit occurs via an M12 4 pins type A male connector. M12 connector has two different pins to power up inputs (pin 1) and outputs (pin 4). Presence of each power supply rail is indicated by corresponding green LED.

**Ordering code**

**5030.M12**



1  
AIR DISTRIBUTION

**Scheme / Overall dimensions and I/O layout**

**M12 4P male connector**

**M12A 4P MALE**

PIN	DESCRIPTION
1	+ 24 VDC
2	NC
3	GND
4	PWR OUT

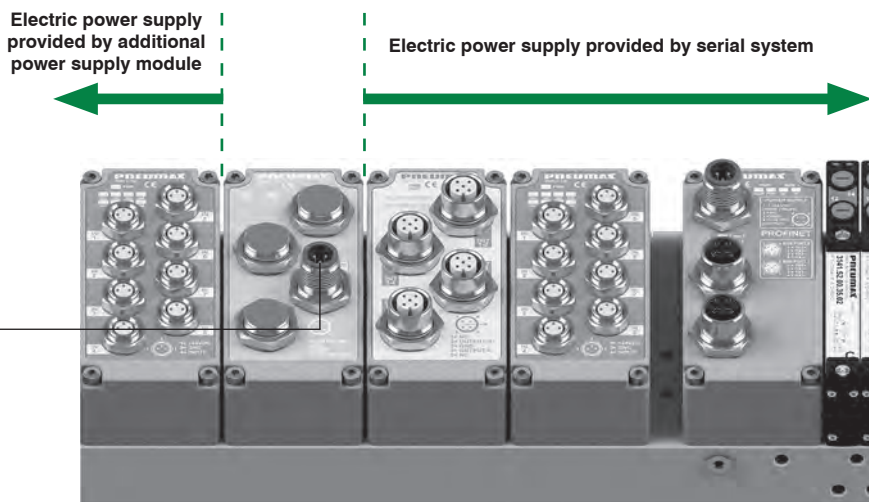

**General - Optional position module**

Optional position module is employed to protect manifold connections where no module has yet been installed. Optional position modules must be installed at the left end of the system, that is downstream the other modules.

**Ordering code**

**5030.T00**



**Configuration example**

The code 5030.T00 can be replaced by any of the modules presented in the previous pages, as long as the availability of the necessary inputs or outputs is checked on the node.





Signal management

64 INPUT + 64 OUTPUT serial systems - 32 fixed OUTPUT (Ex. PROFIBUS DP and CANopen®)

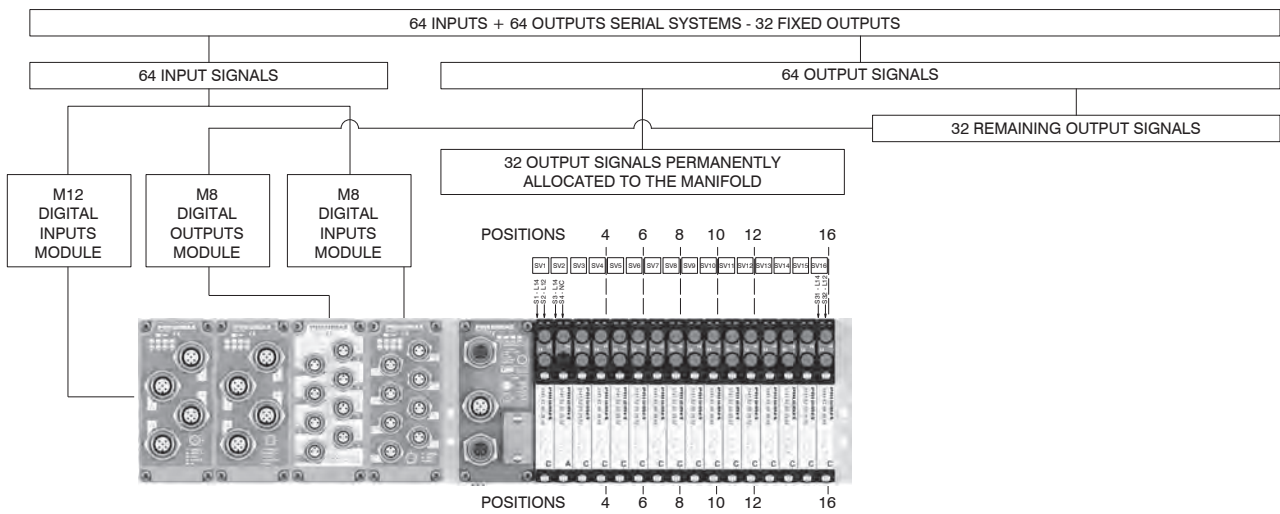

64 INPUT + 64 OUTPUT serial systems - 48 fixed OUTPUT (Ex. PROFIBUS DP and CANopen®)

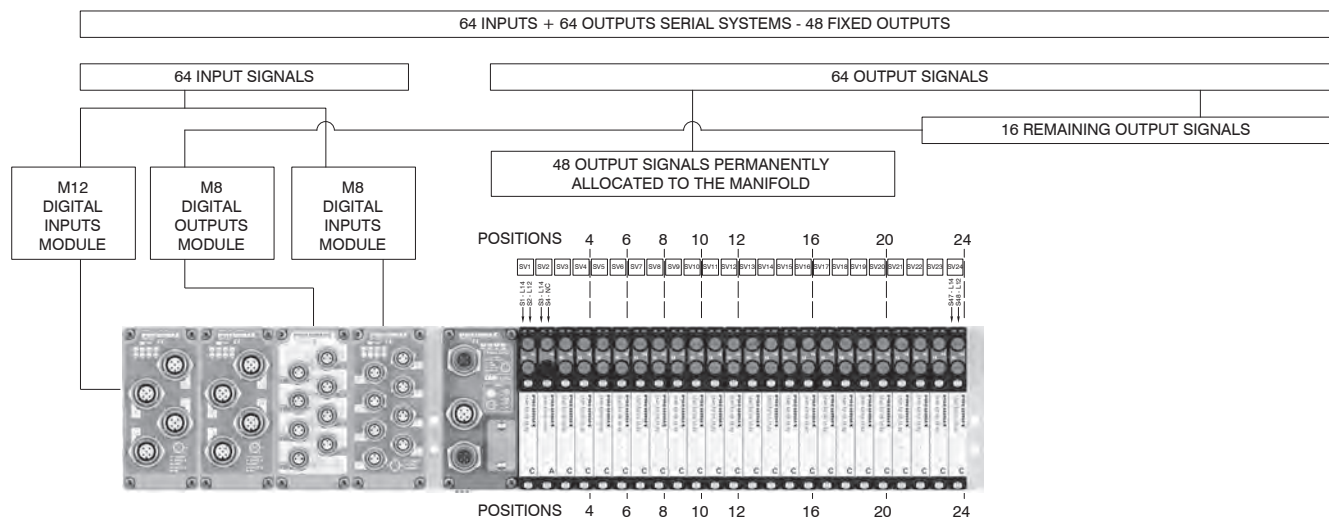

128 INPUT + 128 OUTPUT serial systems - 48 fixed OUTPUT (Ex. EtherNet/IP - EtherCAT® - PROFINET IO RT/IRT)

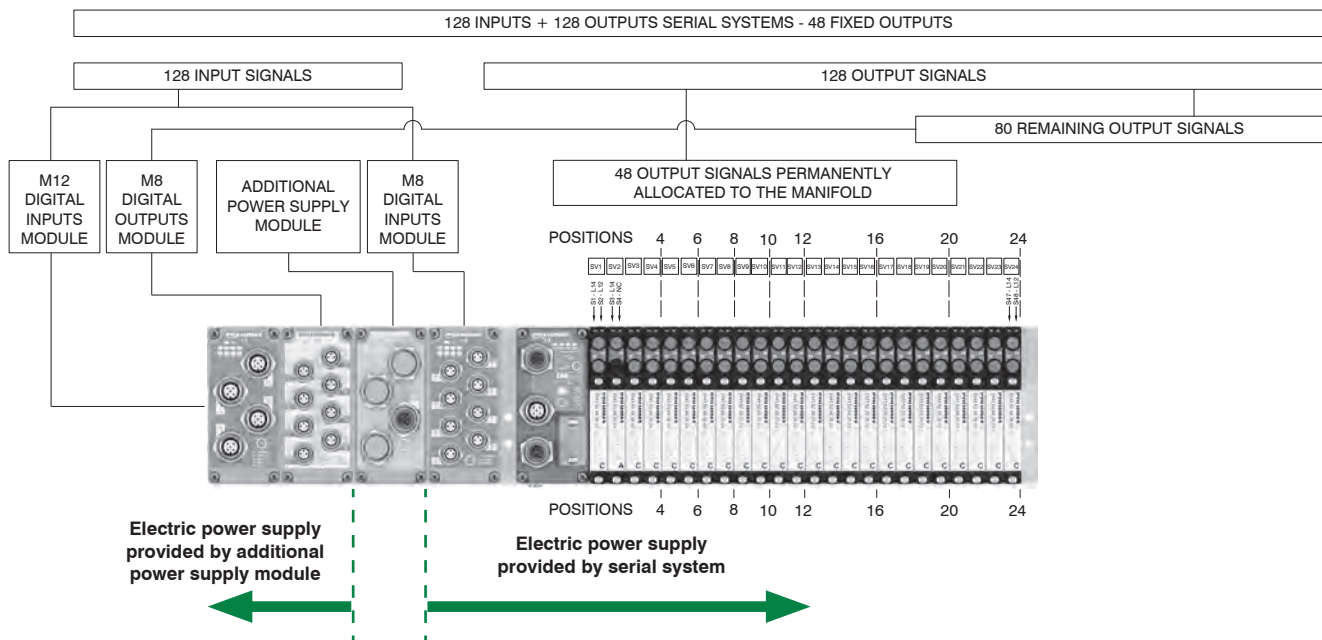

1  
AIR DISTRIBUTION

Section 02

# Air treatment

## Components for compressed air treatment

### Air service units

Wide range of components for compressed air treatment, are available in aluminium, technopolymer and steel, in several sizes with connections from 1/8" to 1" and flow rates up to 8000 NI/m.

	<b>Series AIRPLUS</b>	<b>2.1</b>		
	Product overview	2.3	<b>Regulators</b>	2.33
	Filter	2.5	<b>Piloted pressure regulators</b>	2.39
	Coalescing filter	2.10	<b>Pressure regulators for manifold</b>	2.44
	Oil removal filters	2.15	<b>Manifold pressure regulators</b>	2.48
	Carbon filters	2.20	<b>Lubricators</b>	2.53
	Filter regulators	2.25	<b>Shut off valves</b>	2.58
	Accessories	2.32	<b>Progressive start-up valve</b>	2.62
			<b>Air intake</b>	2.65
			<b>Pressure switch</b>	2.67
		<b>Air intake with pressure gauge or digital pressure switch integrated</b>	2.69	
		<b>Safeline valves</b>	2.75	
		<b>Manifold unit</b>	2.82	
	<b>Series 1700</b>	<b>2.88</b>		
	Product overview	2.88	<b>Piloted pressure regulators</b>	2.115
	Filter	2.90	<b>High sensitive pressure regulator with pneumatic pilot</b>	2.119
	Coalescing filter	2.94	<b>Panel mounting pressure regulator</b>	2.121
	Dynamic drier	2.98	<b>Panel mounting pressure regulator including pressure gauge</b>	2.123
	Filter regulators	2.100	<b>Pressure regulators for manifold</b>	2.125
	Regulators	2.104	<b>Manifold pressure regulators</b>	2.127
	Regulators with integrated pressure gauge	2.109	<b>Lubricators</b>	2.130
	High sensitive air pressure regulators with high flow rate relieving	2.112	<b>Shut-off valve</b>	2.134
			<b>Electric shut-off valve</b>	2.136
			<b>Pneumatic shut-off valve</b>	2.138
			<b>Progressive start-up valve</b>	1.140
			<b>Presa d'aria</b>	2.142
		<b>Air Intake - "H" profile</b>	2.144	
		<b>Pressure Switch complete with adapter</b>	2.146	
		<b>Manifold unit</b>	2.148	
		<b>Accessories</b>	2.156	
	<b>Series 1700 Steel line</b>	<b>2.159</b>		
	<b>Sizes 2</b>	2.160	<b>Sizes 3</b>	2.165
			<b>Sizes 4</b>	2.168

### Proportional technology

The proportional pressure regulators are available in 3 sizes, standard, CANopen® and IO-Link, or miniaturized versions

	<b>Series 1700 standard</b>	<b>2.172</b>		<b>Series 1700 Miniaturized</b>	<b>2.188</b>

### Measuring devices

Digital pressure switches and pressure gauges, panel mounting or manifold versions

	<b>Pressure switches Series DS</b>	<b>2.204</b>		<b>Pressure gauges Series DS</b>	<b>2.206</b>

### Pressure booster

3 sizes aluminium Pressure boosters available or technopolymer with 2:1 compression ratio

	<b>Series 1700</b>	<b>2.208</b>		<b>Series P+</b>	<b>2.213</b>



Product overview

PRODUCT	VERSION	SIZE				MAX. PRESSURE		MIN - MAX AMBIENT TEMPERATURE		ATEX
		Size 1	Size 2	Size 3	Size 4	Technopolymer body or bowl	Metal body and bowl	Technopolymer body or bowl	Metal body and bowl	
FILTER (F)	T : Technopolymer body and thread	•	•	•		13 bar - 10 bar (automatic drain)	/  20 bar - 16 bar (automatic drain)	-5°C +50°C	/  -30°C +80°C  -40°C +80°C	•
	N : Technopolymer body and metal inserts	•	•	•						
	P : Aluminum body		•	•	•					
	L : Aluminum body, low temperature		•	•	•					
COALESCING FILTER (D)	T : Technopolymer body and thread	•	•	•		13 bar - 10 bar (automatic drain)	/  20 bar - 16 bar (automatic drain)	-5°C +50°C	/  -30°C +80°C  -40°C +80°C	•
	N : Technopolymer body and metal inserts	•	•	•						
	P : Aluminum body		•	•	•					
	L : Aluminum body, low temperature		•	•	•					
OIL REMOVAL FILTER (DBV) (DCV) (DAV)	T : Technopolymer body and thread			•		10 bar	/	-5°C +50°C	/	•
	N : Technopolymer body and metal inserts			•						
	P : Aluminum body			•	•					
	L : Aluminum body, low temperature									
CARBON FILTER (DD)	T : Technopolymer body and thread			•		13 bar	/  20 bar	-5°C +50°C	/  -30°C +80°C  -40°C +80°C	•
	N : Technopolymer body and metal inserts			•						
	P : Aluminum body			•	•					
	L : Aluminum body, low temperature			•	•					
REGULATOR (R) (RM) (RW)	T : Technopolymer body and thread	•	•	•		13 bar	20 bar	-5°C +50°C	/  -30°C +80°C  -40°C +80°C	•
	N : Technopolymer body and metal inserts	•	•	•						
	P : Aluminum body		•	•	•					
	L : Aluminum body, low temperature		•	•	•					
PRESSURE REGULATOR FOR MANIFOLD (B) (M)	T : Technopolymer body and thread	•				13 bar	/	-5°C +50°C	/  /	•
	N : Technopolymer body and metal inserts	•								
	P : Aluminum body									
	L : Aluminum body, low temperature									
PILOTED PRESSURE REGULATOR (RP) (RMP) (RPP)	T : Technopolymer body and thread					/	/	/	/	•
	N : Technopolymer body and metal inserts					/	20 bar	/	-30°C +80°C	
	P : Aluminum body				•	/		/	/	
	L : Aluminum body, low temperature					/		/	/	
PILOTED PRESSURE REGULATOR WITH DIGITAL PRESSURE SWITCH (RPP) (RPZ)	T : Technopolymer body and thread					/	/	/	/	•
	N : Technopolymer body and metal inserts					/	20 bar	/	0°C +50°C	
	P : Aluminum body				•	/		/	/	
	L : Aluminum body, low temperature					/		/	/	
FILTER REGULATOR (E) (EM) (EW)	T : Technopolymer body and thread	•	•	•		13 bar - 10 bar (automatic drain)	20 bar - 16 bar (automatic drain)	-5°C +50°C	/  -30°C +80°C  -40°C +80°C	•
	N : Technopolymer body and metal inserts	•	•	•						
	P : Aluminum body		•	•	•					
	L : Aluminum body, low temperature		•	•	•					
REGULATOR WITH DIGITAL PRESSURE SWITCH (RP) (RZ)	T : Technopolymer body and thread	•	•	•		13 bar	20 bar	0°C +50°C	/	•
	N : Technopolymer body and metal inserts	•	•	•						
	P : Aluminum body		•	•	•					
	L : Aluminum body, low temperature		•	•	•					
FILTER REGULATOR WITH DIGITAL PRESSURE SWITCH (E) (EP) (EZ)	T : Technopolymer body and thread	•	•	•		13 bar - 10 bar (automatic drain)	20 bar - 16 bar (automatic drain)	0°C +50°C	/	•
	N : Technopolymer body and metal inserts	•	•	•						
	P : Aluminum body		•	•	•					
	L : Aluminum body, low temperature		•	•	•					
LUBRICATOR (L)	T : Technopolymer body and thread	•	•	•		13 bar	/	-5°C +50°C	/	•
	N : Technopolymer body and metal inserts	•	•	•						
	P : Aluminum body		•	•	•					
	L : Aluminum body, low temperature									

2 AIR TREATMENT



2  
AIR TREATMENT

PRODUCT	VERSION	SIZE				MAX. PRESSURE		MIN - MAX AMBIENT TEMPERATURE		ATEX
		Size 1	Size 2	Size 3	Size 4	Technopolymer body or bowl	Metal body and bowl	Technopolymer body or bowl	Metal body and bowl	
LUBRICATOR WITH ELECTRICAL MINIMUM LEVEL SENSOR (LA) (LC)	T: Technopolymer body and thread	●	●	●		13 bar		-5°C +50°C		
	N: Technopolymer body and metal inserts	●	●	●						
	P: Aluminum body		●	●	●					
	L: Aluminum body, low temperature									
SHUT OFF VALVE (VL)	T: Technopolymer body and thread	●	●	●		13 bar - 10 bar (for size 4)		-5°C +50°C	/	●
	N: Technopolymer body and metal inserts	●	●	●						
	P: Aluminum body		●	●	●					
	L: Aluminum body, low temperature		●	●	●					
PNEUMATIC SHUT OFF VALVE (VP)	T: Technopolymer body and thread	●	●	●		13 bar	20 bar	-5°C +50°C	/	●
	N: Technopolymer body and metal inserts	●	●	●						
	P: Aluminum body		●	●	●					
	L: Aluminum body, low temperature		●	●	●					
ELECTRIC SHUT OFF VALVE (VE)	T: Technopolymer body and thread	●	●	●		10 bar		-5°C +50°C		●
	N: Technopolymer body and metal inserts	●	●	●						
	P: Aluminum body		●	●	●					
	L: Aluminum body, low temperature									
PROGRESSIVE START-UP VALVE (AP)	T: Technopolymer body and thread	●	●	●		13 bar - 10 bar (for size 4)		-5°C +50°C		●
	N: Technopolymer body and metal inserts	●	●	●						
	P: Aluminum body		●	●	●					
	L: Aluminum body, low temperature		●	●	●					
AIR INTAKE (PA)	T: Technopolymer body and thread	●	●	●		13 bar	20 bar	-5°C +50°C	/	●
	N: Technopolymer body and metal inserts	●	●	●						
	P: Aluminum body		●	●	●					
	L: Aluminum body, low temperature									
PRESSURE SWITCH (PP)	T: Technopolymer body and thread	●	●	●		13 bar	20 bar	-5°C +50°C		
	N: Technopolymer body and metal inserts	●	●	●						
	P: Aluminum body		●	●	●					
	L: Aluminum body, low temperature									
AIR INTAKE WITH INTEGRATED PRESSURE GAUGE (PM-PW)	T: Technopolymer body and thread	●	●	●		13 bar		-5°C +50°C	/	●
	N: Technopolymer body and metal inserts	●	●	●						
	P: Aluminum body		●	●	●					
	L: Aluminum body, low temperature									
AIR INTAKE WITH INTEGRATED DIGITAL PRESSURE SWITCH (PP-PZ)	T: Technopolymer body and thread	●	●	●		13 bar		0°C +50°C		
	N: Technopolymer body and metal inserts	●	●	●						
	P: Aluminum body		●	●	●					
	L: Aluminum body, low temperature									



## Air service units, series AIRPLUS

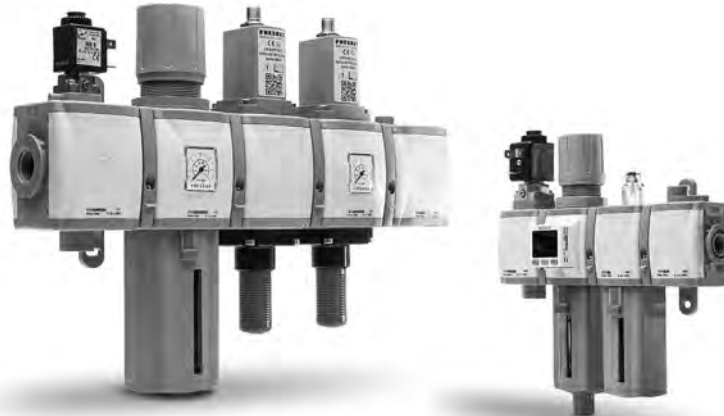

- **Modular system**
- **Compact and linear design**
- **Maximum flexibility and reliability**
- **Plug-n-play connection thru couplig flanges**
- **Integral safety elements in assembled group**
- **Available in 4 sizes with connections from 1/8" to 1"**
- **ATEX certification (II 2GD or II 3GD)**

### Construction and working characteristics

Pneumax AIRPLUS air treatment units have been designed and developed to increase reliability, modularity and user-friendly operation and installation.

Thanks to a wide range of modules with different functions and characteristics, together with a wide choice of materials selection, make the Pneumax AIRPLUS air treatment units a robust, reliable and extremely flexible modular system, adaptable to many applications.

AIRPLUS units correctly assembled are modular with unlimited configurations and solutions, capable of fulfilling all functions of compressed air treatment such as filtration, regulation, lubrication, interception and distribution.

Filters, including coalescing and active carbon elements as well as oil separators provide adequate media filtration. Precise and reliable pressure regulation is provided by the regulators or filter-regulators which are also available with a built in pressure gauge or integral digital pressure switch. The lubricators provide oil mist lubrication in proportion to air being consumed whilst the shut-off valves, which can be operated pneumatic, electro-pneumatic or manually will effectively manage the supply and exhaust of the compressed air system.

The range is completed by a series of complementary modules, such as pneumatic connection by-pass, pressure switch and progressive start-up. The complete assembly is built up using the individual modules connected together via quick coupling flanges which provide a 'plug & play' assembly. This provides quick and easy installation or replacement.

Pneumax Airplus air treatment units can be integrated with safety elements that comply with EN-ISO 13849-1 and CE marking according to EU Machinery Directive, Annex V.

AIRPLUS air treatment units are available in 4 different sizes, with connections from 1/8" to 1" and flow rates performances up to 8000NI/min.

### Instruction for installation and operation

The FRL unit should be installed as close as possible to the 'point of use'. The air flow direction should follow the direction indicated on the individual modules, following threaded connections (IN and OUT). Units fitted with a bowl should be mounted vertically with the bowl facing down.

All units should be operated in accordance to the specified pressure and temperature ranges and should never exceed 0.2 Hz max frequency whether pulsing inlet pressure occur.

Fittings shall be mounted according to the maximum torque specified.

### Maintenance

To carry out maintenance which involves the removal of the caps or supports above the body and where the retaining screws are present, it is necessary to remove the cover plates beforehand. If you attempt to dis-assemble the caps or supports without removing the cover plates and retaining screws, the integrity and function of the device could be compromised.

Bowls, plugs and supports are assembled with a bayonet type mechanism. In order to remove them, rotate anti-clockwise until the mechanical stop is reached and then remove from the body (for the bowls firstly press down the green safety button).

Bowls and transparent parts can be cleaned with water and neutral soap. Do not use solvents or alcohol.

Filtering elements (present in filters and filter regulators) made of HDPE can be regenerated by washing and blowing them.

In order to remove them it is necessary to remove the bowl unscrew the filter element and replace it with a new one or clean it.

Lubricator oil recharge might be performed during normal operation (apart TG1 size) depressurizing the bowl thru dedicated plug.

Pneumax suggest refilling oil directly into the bowl.

No others maintenance operation shall be carried out by client itself, due to complexity of the assembly and Pneumax dedicated post-maintenance testing activities.



### FILTRATION



Filter pore sizes  
from 50  $\mu\text{m}$  to 5  $\mu\text{m}$

Coalescing filter with  
retention efficiency of 99,97%  
particle removal down to 0,01  $\mu\text{m}$

Coalescing/oil removal filter  
with oil residual up to 0,01 ppm

Carbon filter  
with oil residual up to < 0,003 ppm

### REGULATION



Regulators and filter regulators  
Pressure regulation range up to 12 bar

Available with  
integrated pressure gauge,  
pressure switch or G1/8" connection

### LUBRICATION



Manual adjustment of oil quantity  
complete with visual indicator

Oil refilled with  
pressurized circuit

Oil mist lubrication

### SHUT OFF



Manual, pneumatic  
or electropneumatic  
operation availability

Manual version lockable  
up to 3 padlock

### COMPLEMENTARY MODULES

Pressure switch

Air intake

Progressive start-up valve



### SAFETY

Integrated diagnostic system

Single version CAT.2  
in accordance with  
ISO EN 13849 up to PL=C

Double version CAT.4  
in accordance with  
ISO EN 13849 up to PL=E

In accordance with  
EU Machinery directive,  
annex V



2 AIR TREATMENT

Filters (F)



- ▶ Double filter action: air flow centrifugation and filter element
- ▶ Available in 4 sizes with flow rates up to 14000 NI/min and connections from 1/8" to 1"
- ▶ Filtering cartridge made of HDPE available in three different filtration grades (5µm, 20µm, 50µm)
- ▶ Filter cartridge can be regenerated by washing / blowing it or replaced
- ▶ Bowl assembly via bayonet type quick coupling mechanism with safety button
- ▶ Semi-automatic or automatic drain
- ▶ Atex certification (II 2GD or II 3GD)
- ▶ Inlet pressures up to 20 bar

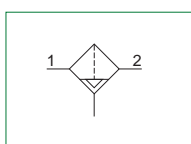
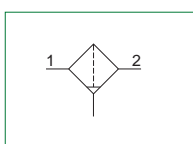

**Note**

In order to ensure that any fluid discharged by the auto drain assembly is adequately drained away, it is recommended you use a 6mm fitting and tube.

Technical characteristics		Size	Size 1	Size 2	Size 3	Size 4
<b>Body and connections type</b>			Technopolymer body, integrated technopolymer connections (T version) Technopolymer body, metal connections (N version)	Aluminium body, integrated aluminium connections (P - L versions)		/
<b>Protection and bowl type</b>			Technopolymer protection - PC bowl Technopolymer protection - PA bowl	Metal protection - PC bowl Metal protection - PA bowl Metal bowl (blind metal bowl)		/
<b>IN / OUT connections</b>	<b>T version</b>		G1/4"	G3/8"	G1/2"	not available
	<b>N version</b>		G1/8" - G1/4" - 1/4" NPT	G3/8" - G1/4" - 3/8" NPT	G3/8" - G1/2" - 1/2" NPT	
	<b>P and L version</b>		not available	G3/8" - 1/4" NPT	G1/2" - 1/2" NPT	G1" - 1" NPT
<b>Assembly configuration</b>			Stand alone			Panel mounted
<b>Assembly positions</b>			Vertical ±5°			
<b>Filter pore size</b>			5 µm 20 µm 50 µm			
<b>Bowl capacity</b>			18 cm <sup>3</sup>	34 cm <sup>3</sup>	68 cm <sup>3</sup>	90 cm <sup>3</sup>
<b>Condensation drain</b>			Semi-automatic Automatic			
<b>Max. fittings torque IN / OUT connections</b>			G1/8" metal: 15Nm G1/4" metal: 20Nm G1/4" technopolymer: 9Nm	G1/4" metal: 20Nm G3/8" metal: 25Nm G3/8" technopolymer: 16Nm	G3/8" metal: 25Nm G1/2" metal: 30Nm G1/2" technopolymer: 22Nm	G1" metal: 35Nm

Operational characteristics								
Size	Size 1	Size 2	Size 3	Size 4	Size 1	Size 2	Size 3	Size 4
<b>Condensation drain</b>	Semi-automatic				Automatic			
<b>Maximum working pressure</b>	13 bar	20 bar (only with body and metal bowl)			10 bar	16 bar (only with body and metal bowl)		
<b>Minimum working pressure</b>	0,5 bar				0,5 bar			
<b>Working temperature</b>	-5°C +50°C		-30°C +80°C (only for P version and metal bowl) -40°C +80°C (only for L version and metal bowl)		-5°C +50°C			

2  
AIR TREATMENT

Weights					
	Size	Size 1	Size 2	Size 3	Size 4
Fully technopolymer version		129 g	226 g	355 g	/
Technopolymer body version, aluminium bowl protection and technopolymer bowl		/	257 g	393 g	/
Technopolymer body version, aluminium bowl		/	301 g	465 g	/
Aluminium body version, technopolymer protection and bowl		/	314 g	477 g	1163 g
Aluminium body version, aluminium bowl protection and technopolymer bowl		/	344 g	514 g	1306 g
Aluminium body version and aluminium bowl		/	389 g	587 g	1330 g

**Materials**

Exploded sectioned

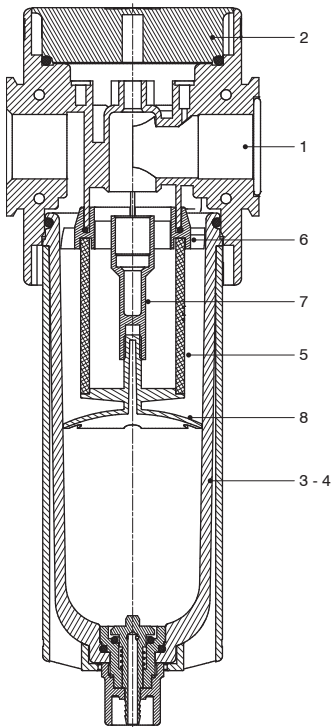

Filter		
1	Body	Polyamide Die-cast aluminium
2	Plug	Polyamide
3	Technopolymer bowl	Polycarbonate Polyamide
4	Metal bowl Bowl protection	Die-cast aluminium Polyamide - Die-cast aluminium
5	Filtering element	Polyethylene
6	Baffle	Acetal resin
7	Spool support	Acetal resin
8	Filtering element support	Acetal resin

2  
AIR TREATMENT

**Design**

**Size 1 - Size 2 - Size 3**  
Technopolymer protection

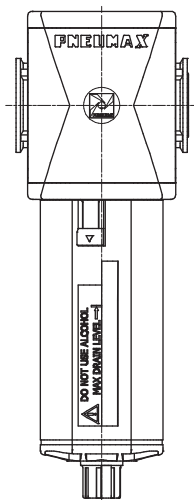

**Size 1 - Size 2 - Size 3**  
Protection / Metal bowl

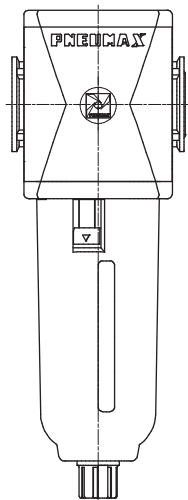

**Size 4**  
All versions

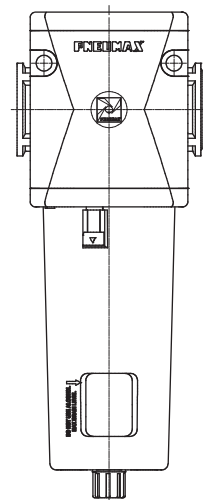



Order codes

	<b>T</b>	17	<b>3B</b>	F	<b>B</b>	<b>S</b>	<b>T</b>
<b>Version</b>							
N : Technopolymer body and metal inserts (not available for size 4)							
T : Technopolymer body and thread (not available for size 4)							
P : Aluminum body (not available for size 1)							
L : Aluminum body, low temperature (not available for size 1)							
<b>Size and connections</b>							
1A : Size 1 - G1/8" only for N version							
1B : Size 1 - G1/4" only for T - N versions							
1C : Size 1 - 1/4" NPT only for N version							
2A : Size 2 - G1/4" only for N version							
2B : Size 2 - G3/8" for all versions							
2C : Size 2 - 3/8" NPT only for N version - 1/4" NPT only for P - L versions							
3A : Size 3 - G3/8" only for N version							
3B : Size 3 - G1/2" for all versions							
3C : Size 3 - 1/2" NPT only for N - P - L versions							
4B : Size 4 - G1" only for P - L versions							
4C : Size 4 - 1" NPT only for P - L versions							
<b>Filter pore size</b>							
A : 5 μm							
B : 20 μm							
C : 50 μm							
<b>Condensation drain</b>							
: Semi-automatic drain							
S : Automatic drain							
<b>Bowl options</b>							
: Technopolymer protection - PC bowl							
N : Technopolymer protection - PA bowl							
P : Metal protection - PC bowl (not available for size 1)							
R : Metal protection - PA bowl (not available for size 1)							
T : Metal bowl (not available for size 1)							

**Example : T173BFBST** : Size 3 filter G1/2" 20 μm, automatic drain and metal bowl

**Characteristic curves**

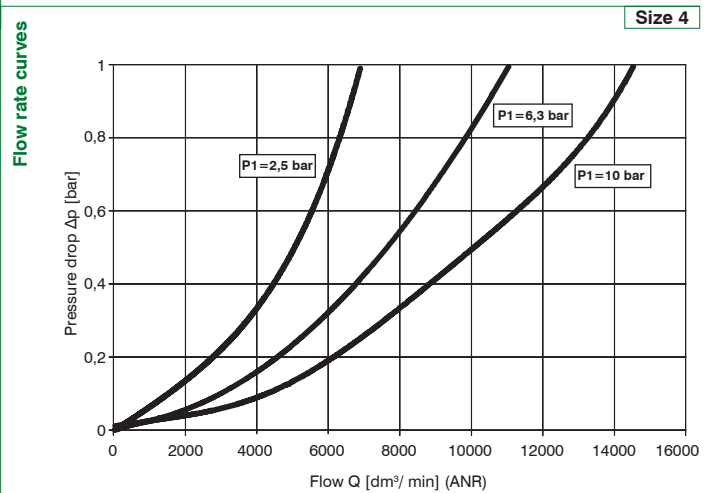
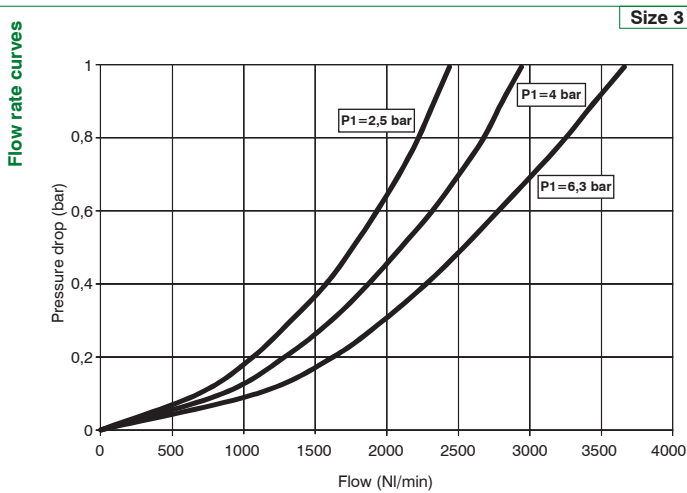
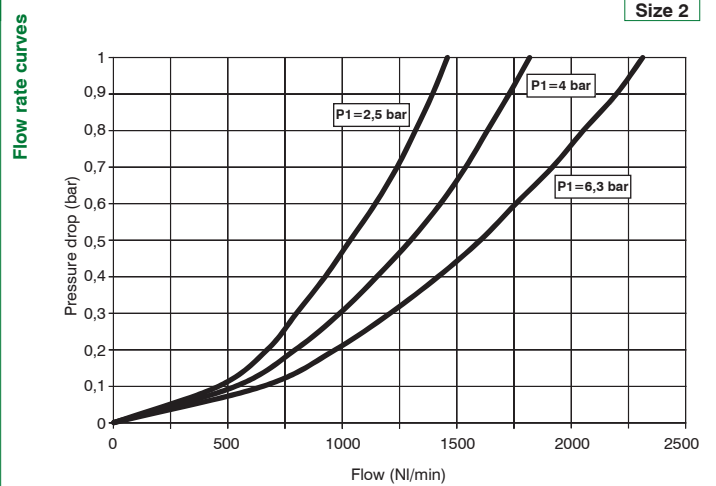
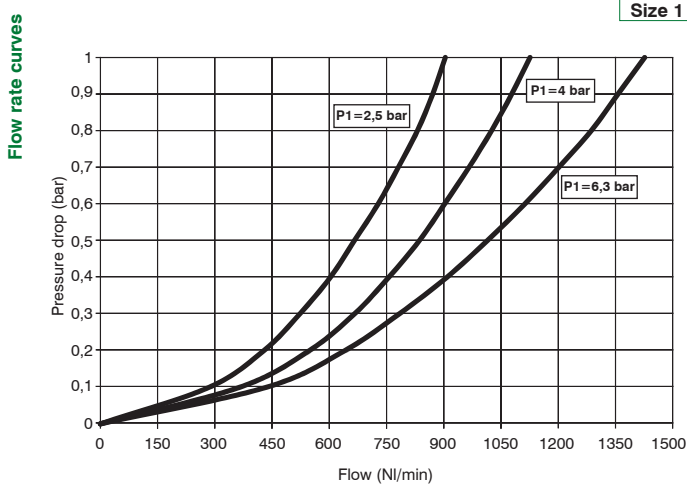

**Dimensions**

Semi-automatic drain version

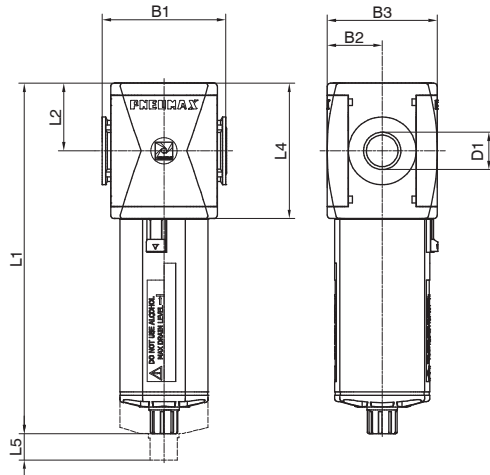

Fixing holes dimension detail (only for size 4)

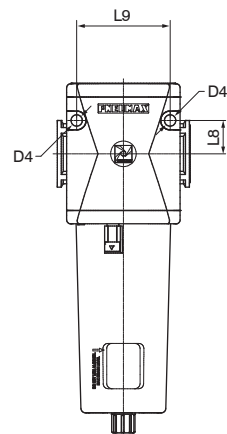

Model	B1	B2	B3	D1	D4	L1 - Bowl material		L2	L4	L5	L8	L9
						Technopolymer	Metal					
#171..	48	21	42	G1/8" G1/4" 1/4" NPT	/	148	/	27,5	55	40	/	/
#172..	62	28,5	57	G1/4" G3/8" 1/4" NPT 3/8" NPT	/	169,1	171,5	34	68	50	/	/
#173..	73	32,5	65	G3/8" G1/2" 1/2" NPT	/	207,2	209,5	40	80	65	/	/
#174..	99	44	88	G1" 1" NPT	8,5	262	264,5	52,5	105	103	25	70

Variable dimensions

Semi-automatic drain version

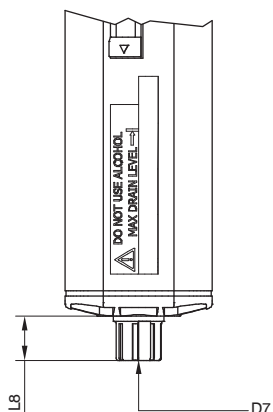

Automatic drain version

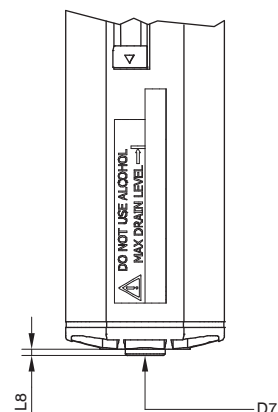

Model	L8 - Bowl material		D7
	Technopolymer	Metal	
Semi-automatic drain	15,7	18	Plastic hose connector
Automatic drain	2	4,5	G1/8"

► **Coalescing filters (DA)**



- Coalescing filter
- Available in 4 sizes with flow rates up to 8000 NI/min and connections from 1/8" to 1"
- Filtering cartridge with filtration grade of 0,01 μm
- Filtering performances 99.97% (particles up to 0.01 μm)
- Bowl assembly via bayonet type quick coupling mechanism with safety button
- Semi-automatic or automatic drain
- Atex certification (II 2GD or II 3GD)
- Inlet pressures up to 20 bar

2

AIR TREATMENT

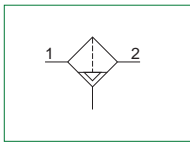
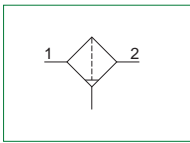

**Note**

In order to ensure the high level of filtration, it is recommended that a 5μ filter is installed before the coalescing filter. In order to ensure that any fluid discharged by the auto drain assembly is adequately drained away, it is recommended you use a 6mm fitting and tube.

Technical characteristics		Size	Size 1	Size 2	Size 3	Size 4
<b>Body and connections type</b>			Technopolymer body, integrated technopolymer connections (T version) Technopolymer body, metal connections (N version)	Aluminium body, integrated aluminium connections (P - L versions)		/ /
<b>Protection and bowl type</b>			Technopolymer protection - PC bowl Technopolymer protection - PA bowl	Metal protection - PC bowl Metal protection - PA bowl Metal bowl (blind metal bowl)		
<b>IN / OUT connections</b>	<b>T version</b>		G1/4"	G3/8"	G1/2"	not available
	<b>N version</b>		G1/8" - G1/4" - 1/4" NPT	G3/8" - G1/4" - 3/8" NPT	G3/8" - G1/2" - 1/2" NPT	
	<b>P and L version</b>		not available	G3/8"	G1/2"	G1"
<b>Assembly configuration</b>			Stand alone			Panel mounted
<b>Assembly positions</b>			Vertical ±5°			
<b>Filter pore size</b>			0,01 μm, efficiency of 99,97%			
<b>Bowl capacity</b>			18 cm <sup>3</sup>	34 cm <sup>3</sup>	68 cm <sup>3</sup>	90 cm <sup>3</sup>
<b>Condensation drain</b>			Semi-automatic Automatic			
<b>Max. fittings torque IN / OUT connections</b>			G1/8" metal: 15Nm G1/4" metal: 20Nm G1/4" technopolymer: 9Nm	G1/4" metal: 20Nm G3/8" metal: 25Nm G3/8" technopolymer: 16Nm	G3/8" metal: 25Nm G1/2" metal: 30Nm G1/2" technopolymer: 22Nm	G1" metal: 35Nm

Operational characteristics								
Size	Size 1	Size 2	Size 3	Size 4	Size 1	Size 2	Size 3	Size 4
<b>Condensation drain</b>	Semi-automatic				Automatic			
<b>Maximum working pressure</b>	13 bar	20 bar (only with body and metal bowl)			10 bar	16 bar (only with body and metal bowl)		
<b>Minimum working pressure</b>	0,5 bar				0,5 bar			
<b>Working temperature</b>	-5°C +50°C		-30°C +80°C (only for P version and metal bowl) -40°C +80°C (only for L version and metal bowl)		-5°C +50°C			



Weights					
	Size	Size 1	Size 2	Size 3	Size 4
Fully technopolymer version		130 g	224 g	366 g	/
Technopolymer body version, aluminium bowl protection and technopolymer bowl		/	251 g	402 g	/
Technopolymer body version, aluminium bowl		/	293 g	475 g	/
Aluminium body version, technopolymer protection and bowl		/	309 g	493 g	1197 g
Aluminium body version, aluminium bowl protection and technopolymer bowl		/	337 g	529 g	1340 g
Aluminium body version and aluminium bowl		/	378 g	603 g	1365 g

**Materials**

Exploded sectioned

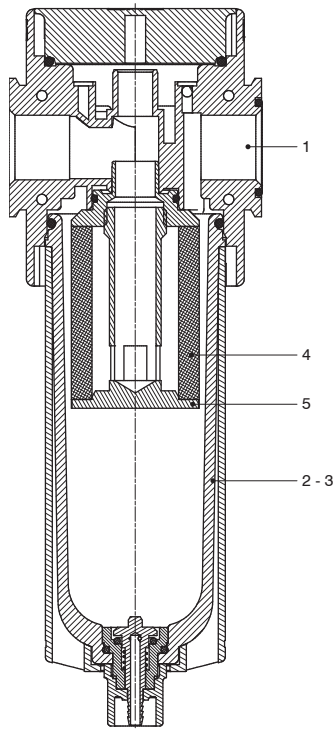

Coalescing filter		
1	Body	Polyamide Die-cast aluminium
2	Technopolymer bowl	Polycarbonate Polyamide
3	Metal bowl Bowl protection	Die-cast aluminium Polyamide - Die-cast aluminium
4	Filtering element	Borosilicate glass fiber
5	Filtering element support	Aluminium

2

AIR TREATMENT

**Design**

Size 1 - Size 2 - Size 3  
Technopolymer protection

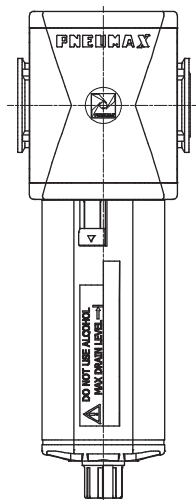

Size 1 - Size 2 - Size 3  
Protection / Metal bowl

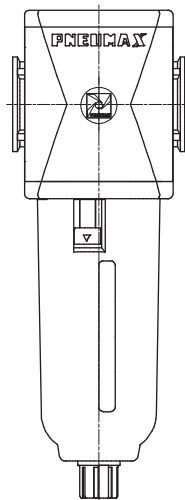

Size 4  
All versions

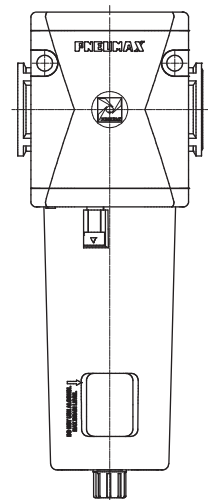



**Order codes**

T 17 3B DA S T

Version
N : Technopolymer body and metal inserts (not available for size 4)
T : Technopolymer body and thread (not available for size 4)
P : Aluminum body (not available for size 1)
L : Aluminum body, low temperature (not available for size 1)

Size and connections
1A : Size 1 - G1/8" only for N version
1B : Size 1 - G1/4" only for T - N versions
1C : Size 1 - 1/4" NPT only for N version
2A : Size 2 - G1/4" only for N version
2B : Size 2 - G3/8" for all versions
2C : Size 2 - 3/8" NPT only for N version
3A : Size 3 - G3/8" only for N version
3B : Size 3 - G1/2" for all versions
3C : Size 3 - 1/2" NPT only for N version
4B : Size 4 - G1" only for P - L versions

Condensation drain
: Semi-automatic drain
S : Automatic drain

Bowl options
: Technopolymer protection - PC bowl
N : Technopolymer protection - PA bowl
P : Metal protection - PC bowl (not available for size 1)
R : Metal protection - PA bowl (not available for size 1)
T : Metal bowl (not available for size 1)

**Example : T173BDAST** : Size 3 coalescing filter G1/2" 0,01 µm, automatic drain and metal bowl

2  
AIR TREATMENT

Characteristic curves

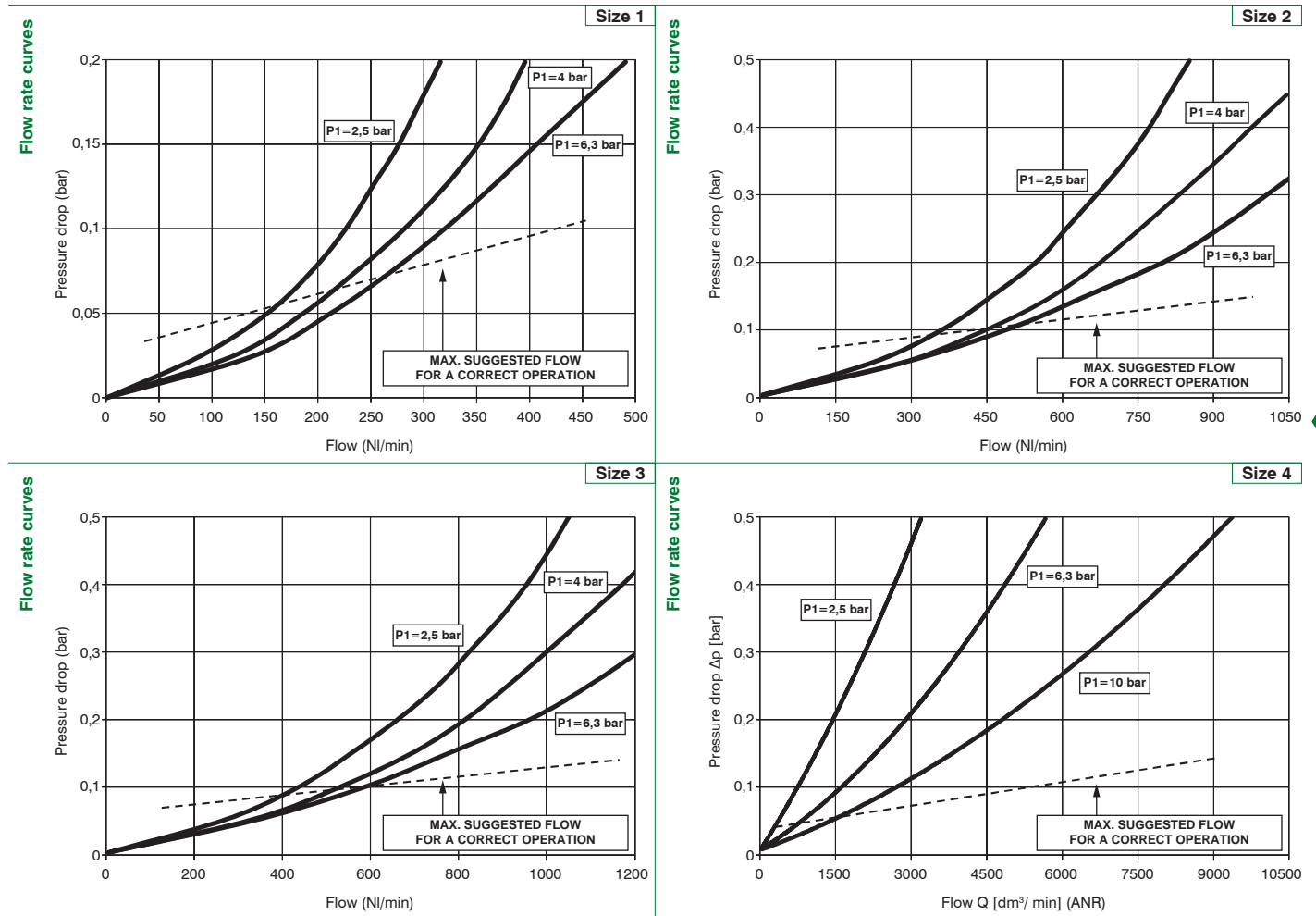

2

AIR TREATMENT

Dimensions

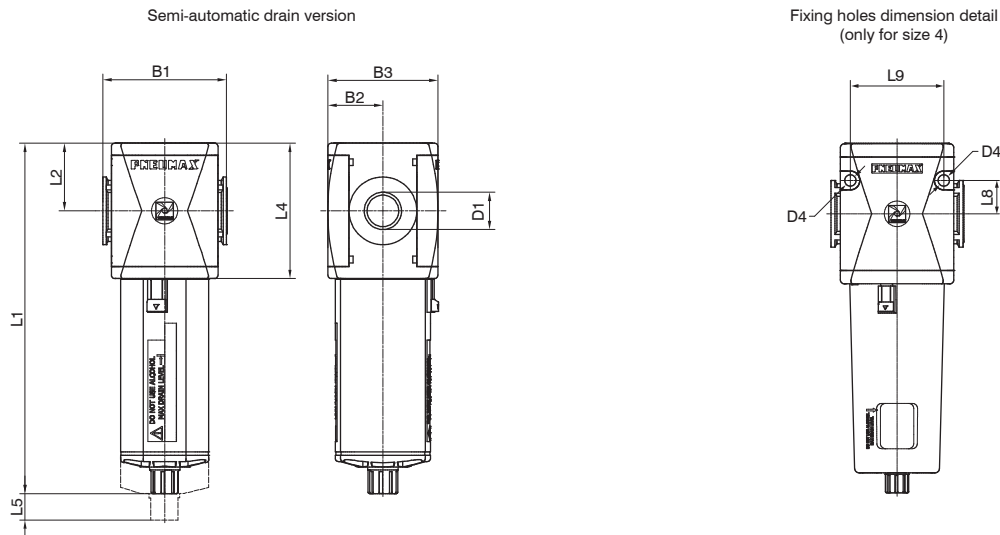

Model	B1	B2	B3	D1	D4	L1 - Bowl material		L2	L4	L5	L8	L9
						Technopolymer	Metal					
#171..	48	21	42	G1/8" G1/4" 1/4" NPT	/	148	/	27,5	55	40	/	/
#172..	62	28,5	57	G1/4" G3/8" 1/4" NPT 3/8" NPT	/	169,1	171,5	34	68	50	/	/
#173..	73	32,5	65	G3/8" G1/2" 1/2" NPT	/	207,2	209,5	40	80	65	/	/
#174..	99	44	88	G1" 1" NPT	8,5	262	264,5	52,5	105	103	25	70

Variable dimensions

Semi-automatic drain version

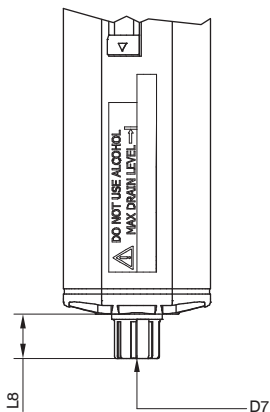

Automatic drain version

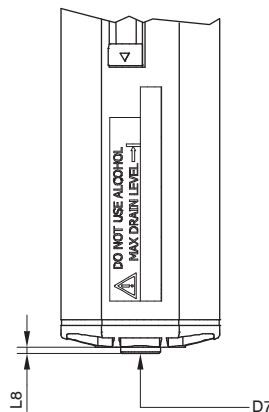

2

AIR TREATMENT

Model	L8 - Bowl material		D7
	Technopolymer	Metal	
Semi-automatic drain	15,7	18	Plastic hose connector
Automatic drain	2	4,5	G1/8"

Oil removal filters (DBV - DCV - DAV)



- ▶ Oil removal filter with coalescing filter element
- ▶ Available in 2 sizes with connections from 3/8" to 1"
- ▶ Particle removal up to 0,01 μm
- ▶ Oil residual 0,01 ppm
- ▶ Cartridge clogging level display:
  - green color - ok
  - red color - warning ( $\Delta p > 0,5$  bar)
- ▶ Bowl assembly via bayonet type quick coupling mechanism with safety button
- ▶ Automatic drain mounted as standard
- ▶ Atex certification (II 2GD or II 3GD)

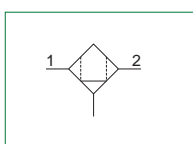

**Note**

In order to ensure the high level of filtration, it is recommended that a 5μ filter is installed before the coalescing filter. In order to ensure that any fluid discharged by the auto drain assembly is adequately drained away, it is recommended you use a 6mm fitting and tube.

Technical characteristics		Size	Size 3	Size 4
<b>Body and connections type</b>		Technopolymer body, integrated technopolymer connections (T version) Technopolymer body, metal connections (N version)		Aluminium body, integrated aluminium connections (P version)
<b>Protection and bowl type</b>		Technopolymer protection - PC bowl Technopolymer protection - PA bowl Metal protection - PC bowl Metal protection - PA bowl Metal bowl (blind metal bowl)		
<b>IN / OUT connections</b>	<b>T version</b>	G1/2"		not available
	<b>N version</b>	G3/8" - G1/2" - 1/2" NPT		
	<b>P version</b>	G1/2"		G1"
<b>Assembly configuration</b>		Stand alone		Panel mounted
<b>Assembly positions</b>		Vertical $\pm 5^\circ$		
<b>Filter pore size</b>		Particle removal up to 0,01 μm Oil residual 0,01 ppm		
<b>Bowl capacity</b>		30 cm <sup>3</sup>		90 cm <sup>3</sup>
<b>Condensation drain</b>		Automatic		
<b>Max. fittings torque IN / OUT connections</b>		G3/8" metal: 25Nm G1/2" metal: 30Nm G1/2" technopolymer: 22Nm		G1" metal: 35Nm

Operational characteristics		Size	Size 3	Size 4
<b>Condensation drain</b>		Automatic		
<b>Maximum working pressure</b>		10 bar		
<b>Minimum working pressure</b>		0,5 bar		
<b>Working temperature</b>		-5°C +50°C		

Weights				
	Size	Size 3 Standard cartridge	Size 3 Oversize cartridge	Size 4
Fully technopolymer version		416 g	634 g	/
Technopolymer body version, aluminium bowl protection and technopolymer bowl		453 g	671 g	/
Technopolymer body version, aluminium bowl		526 g	742 g	/
Aluminium body version, technopolymer protection and bowl		538 g	661 g	1230 g
Aluminium body version, aluminium bowl protection and technopolymer bowl		575 g	698 g	1374 g
Aluminium body version and aluminium bowl		647 g	769 g	1398 g

**Materials**

Exploded sectioned

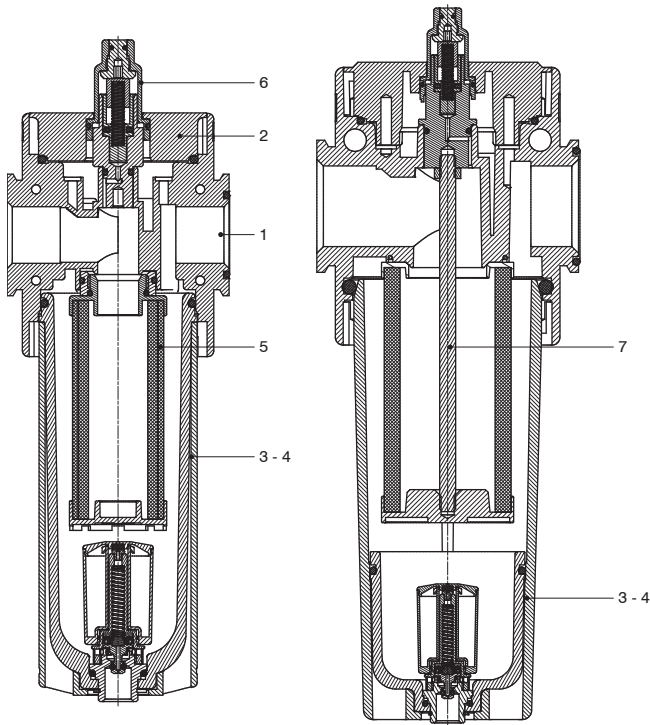

Oil removal filter		
1	Body	Polyamide Die-cast aluminium
2	Upper plug	Polyamide
3	Technopolymer bowl	Polycarbonate Polyamide
4	Metal bowl Bowl protection	Die-cast aluminium Polyamide - Die-cast aluminium
5	Filtering element	/
6	Visual indicator	Polycarbonate
7	Tie rod	Steel (only for size 4)
8	Automatic drain	/

2  
AIR TREATMENT

**Design**

**Size 3**  
Technopolymer protection

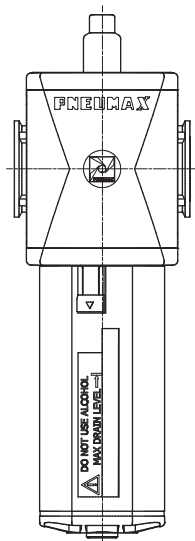

**Size 3**  
Protection / Metal bowl

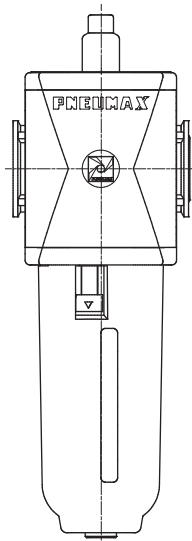

**Size 3 - Oversize cartridge**  
Technopolymer protection

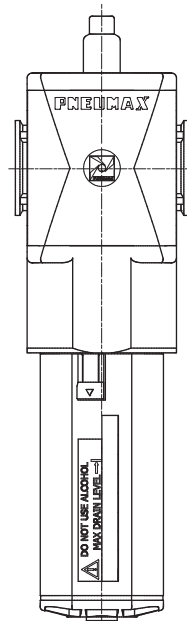

**Size 4**  
All versions

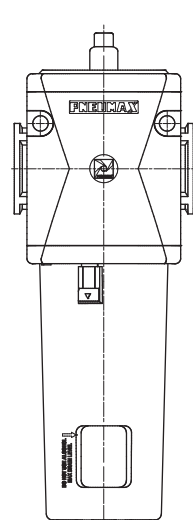

Order codes

T 17 3BDBV T

Version
N : Technopolymer body and metal inserts (not available for size 4)
T : Technopolymer body and thread (not available for size 4)
P : Aluminium body

Size and connections
3ADBV : Size 3 - G3/8" standard cartridge only for N version
3BDBV : Size 3 - G1/2" standard cartridge for all versions
3CDBV : Size 3 - 1/2" NPT standard cartridge only for N version
3BDCV : Size 3 - G1/2" oversize cartridge only for P version
4BDAV : Size 4 - G1" standard cartridge only for P version

Bowl options
: Technopolymer protection - PC bowl
N : Technopolymer protection - PA bowl
P : Metal protection - PC bowl
R : Metal protection - PA bowl
T : Metal bowl

Example : T173BDBVT : Size 3 oil removal filter G1/2", standard cartridge, metal bowl

Characteristic curves

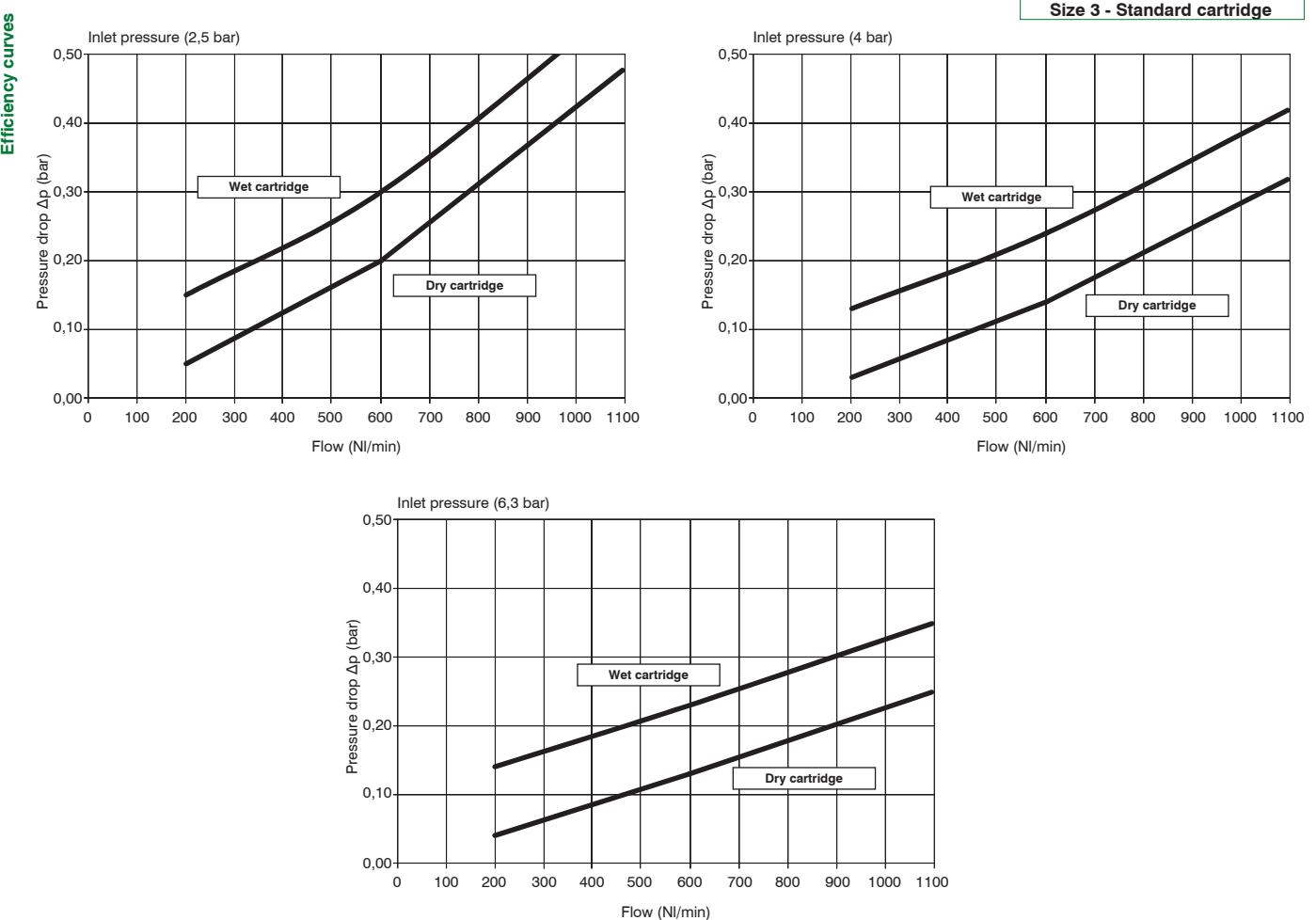



**Size 3 - Oversize cartridge**

Efficiency curves

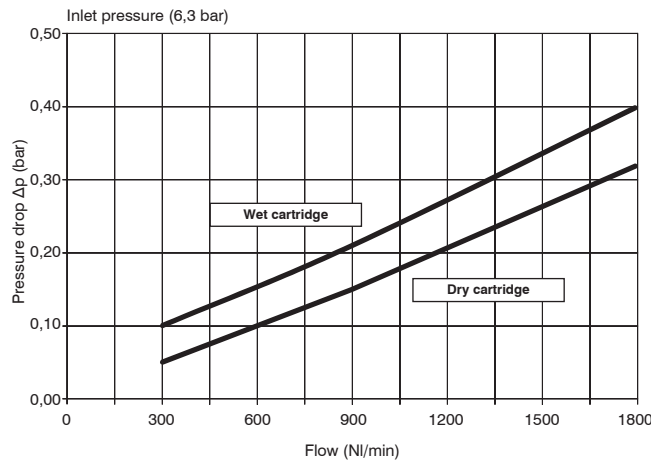
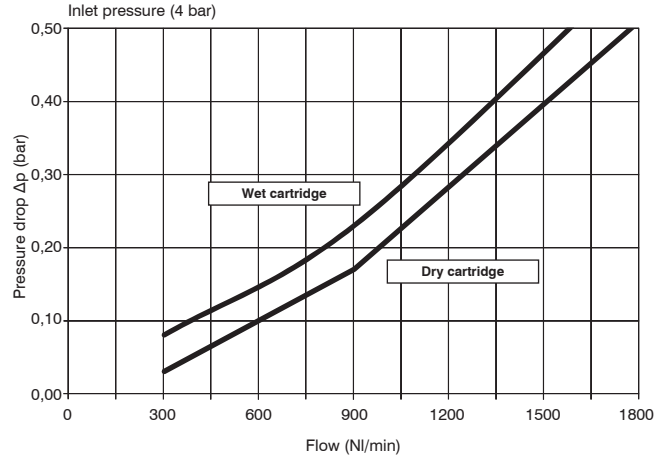
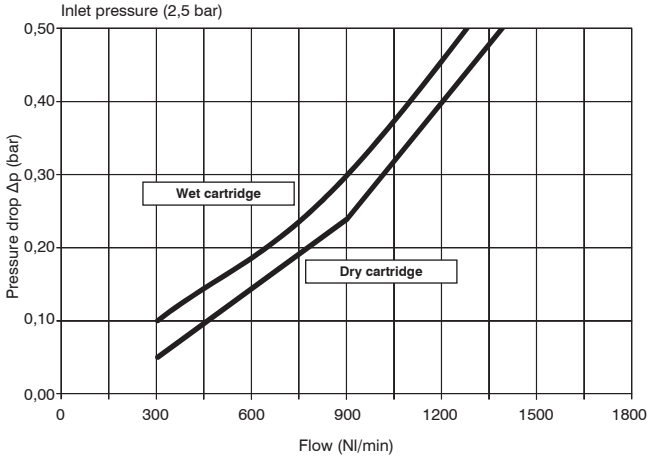

**Size 4 - Standard cartridge**

Efficiency curves

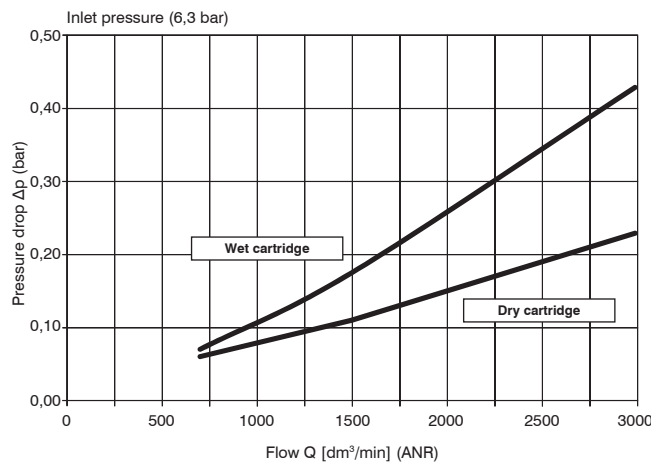
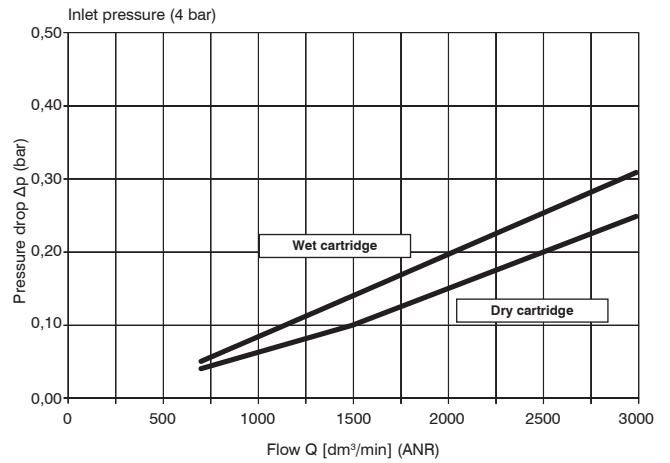
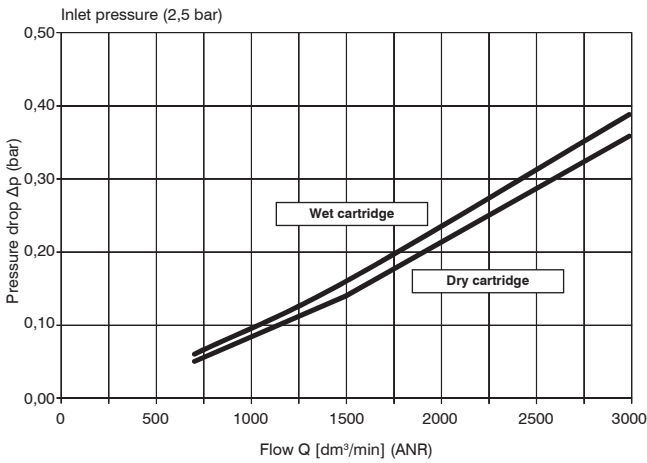



Dimensions

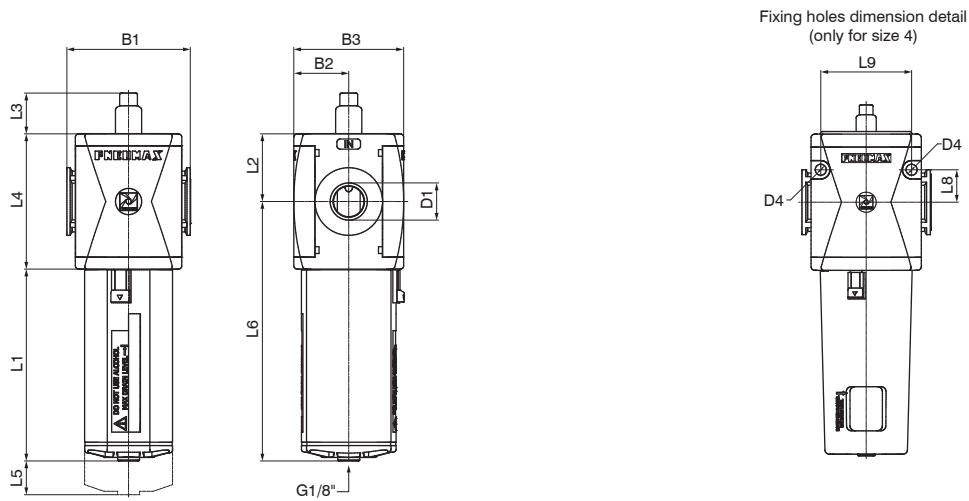

Model	B1	B2	B3	D1		L1 - Bowl material		L3	L4		L5	L8	L9
				Standard cartridge	Oversize cartridge	Technopolymer	Metal		Standard cartridge	Oversize cartridge			
#173..	73	32,5	65	G3/8" G1/2" 1/2" NPT	G1/2"	113,5	116	24,1	80	118	65	/	/
#174..	99	44	88	G1"	/	143	145,5	22,5	105	/	103	25	70

► Carbon filters (DD)



- Carbon filter
- Available in 2 sizes with connections from 3/8" to 1"
- Active carbon cartridge with built in particulate filter
- Used to remove oil vapours, hydrocarbons, odours and particles
- Oil residue up to <0,003 ppm (max input aerosol 0.01 ppm)
- High absorption capacity, with low differential pressure
- Filtering performances 99.97% (particles up to 0.01 μm)
- Bowl assembly via bayonet type quick coupling mechanism with safety button
- Semi-automatic drain
- Atex certification (II 2GD or II 3GD)
- Inlet pressures up to 20 bar

2

AIR TREATMENT

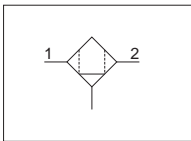

**Note**

A 5μ filter, coalescing filter and oil removing filter must be installed prior to the carbon filter, this is to ensure that the carbon filter operates correctly and safe guard the life of the active carbon element. It may also be necessary to replace the carbon element at fixed intervals.

Technical characteristics			
	Size	Size 3	Size 4
<b>Body and connections type</b>		Technopolymer body, integrated technopolymer connections (T version) Technopolymer body, metal connections (N version)	/ /
		Aluminium body, integrated aluminium connections (P - L versions)	
<b>Protection and bowl type</b>		Technopolymer protection - PC bowl Technopolymer protection - PA bowl Metal protection - PC bowl Metal protection - PA bowl Metal bowl (blind metal bowl)	
<b>IN / OUT connections</b>	<b>T version</b>	G1/2"	not available
	<b>N version</b>	G3/8" - G1/2" - 1/2" NPT	
	<b>P and L version</b>	G1/2"	G1"
<b>Assembly configuration</b>		Stand alone	Panel mounted
<b>Assembly positions</b>		Vertical ±5°	
<b>Oil residue</b>		< 0,003 ppm (max input aerosol 0.01 ppm)	
<b>Bowl capacity</b>		68 cm <sup>3</sup>	90 cm <sup>3</sup>
<b>Condensation drain</b>		Semi-automatic	
<b>Max. fittings torque IN / OUT connections</b>		G3/8" metal: 25Nm G1/2" metal: 30Nm G1/2" technopolymer: 22Nm	G1"metal: 35Nm

Operational characteristics			
	Size	Size 3	Size 4
<b>Condensation drain</b>		Semi-automatic	
<b>Maximum working pressure</b>		13 bar 20 bar (only with body and metal bowl)	
<b>Minimum working pressure</b>		0,5 bar	
<b>Working temperature</b>		-5°C +50°C -30°C +80°C (only for P version and metal bowl) -40°C +80°C (only for L version and metal bowl)	
<b>Cartridge life</b>		2000 hours	

Weights			
	Size	Size 3	Size 4
Fully technopolymer version		395 g	/
Technopolymer body version, aluminium bowl protection and technopolymer bowl		432 g	/
Technopolymer body version, aluminium bowl		505 g	/
Aluminium body version, technopolymer protection and bowl		518 g	1201 g
Aluminium body version, aluminium bowl protection and technopolymer bowl		554 g	1344 g
Aluminium body version and aluminium bowl		628 g	1368 g

**Materials**

Exploded sectioned

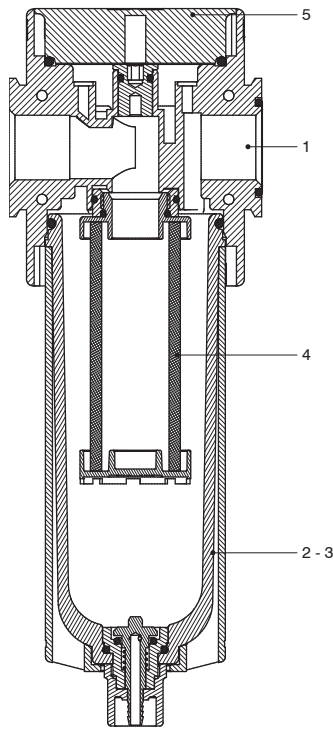

Carbon filter		
1	Body	Polyamide Die-cast aluminium
2	Technopolymer bowl	Polycarbonate Polyamide
3	Metal bowl Bowl protection	Die-cast aluminium Polyamide - Die-cast aluminium
4	Filtering element	Activated carbon
5	Plug	Polyamide Die-cast aluminium

2

AIR TREATMENT

**Design**

**Size 3**  
Technopolymer protection

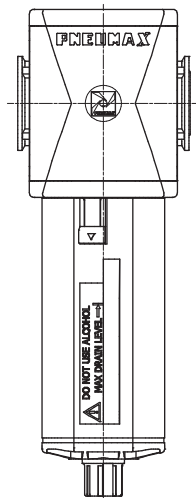

**Size 3**  
Protection / Metal bowl

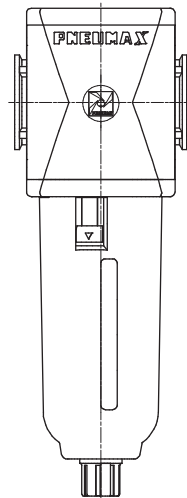

**Size 4**  
All versions

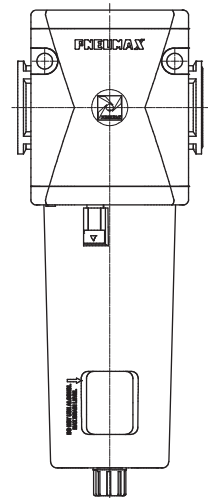



**Order codes**

T 17 3B DD T

Version
<b>N</b> : Technopolymer body and metal inserts (not available for size 4)
<b>T</b> : Technopolymer body and thread (not available for size 4)
<b>P</b> : Aluminium body
<b>L</b> : Aluminium body, low temperature

Size and connections
<b>3A</b> : Size 3 - G3/8" only for N version
<b>3B</b> : Size 3 - G1/2" for all versions
<b>3C</b> : Size 3 - 1/2" NPT only for N version
<b>4B</b> : Size 4 - G1" only for P - L versions

Bowl options
: Technopolymer protection - PC bowl
<b>N</b> : Technopolymer protection - PA bowl
<b>P</b> : Metal protection - PC bowl
<b>R</b> : Metal protection - PA bowl
<b>T</b> : Metal bowl

**Example : T173BDDT** : Size 3 carbon filter G1/2" metal bowl

2 AIR TREATMENT

Characteristic curves

Size 3

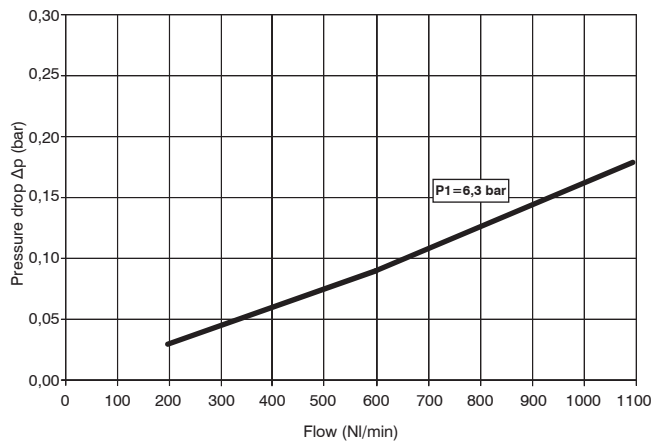
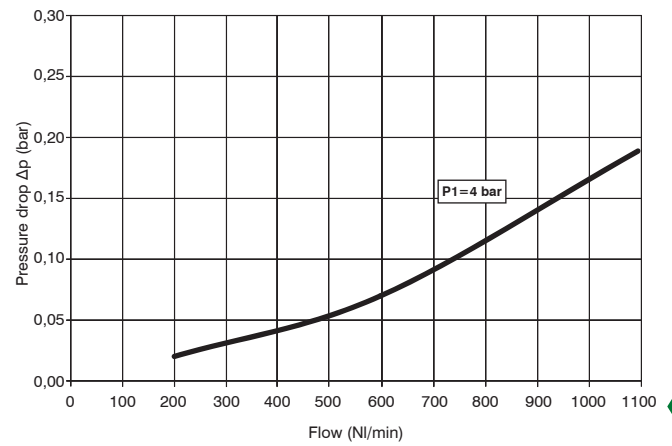
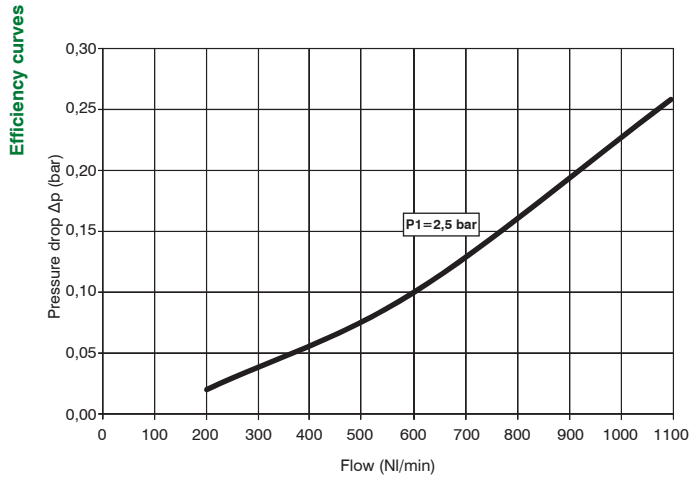

Size 4

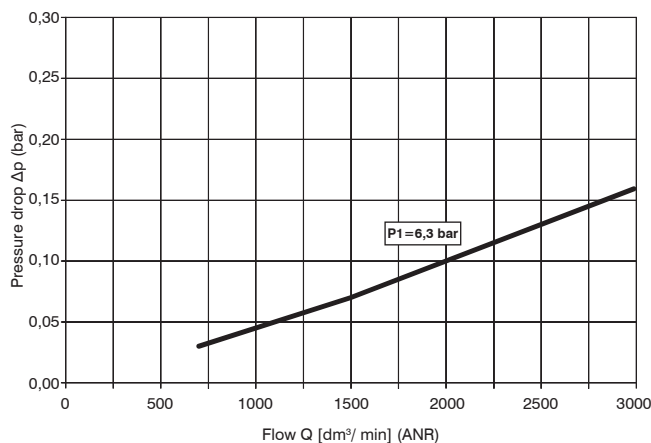
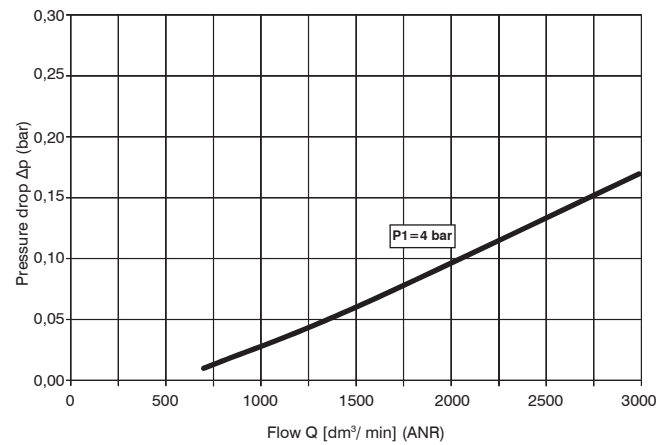
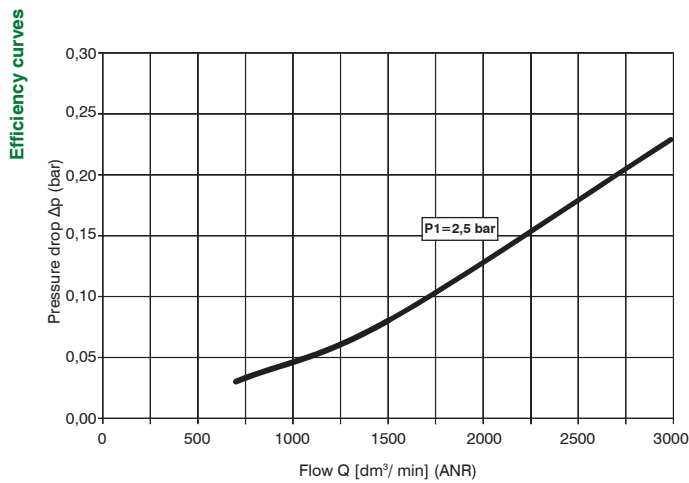

2

AIR TREATMENT

**Dimensions**

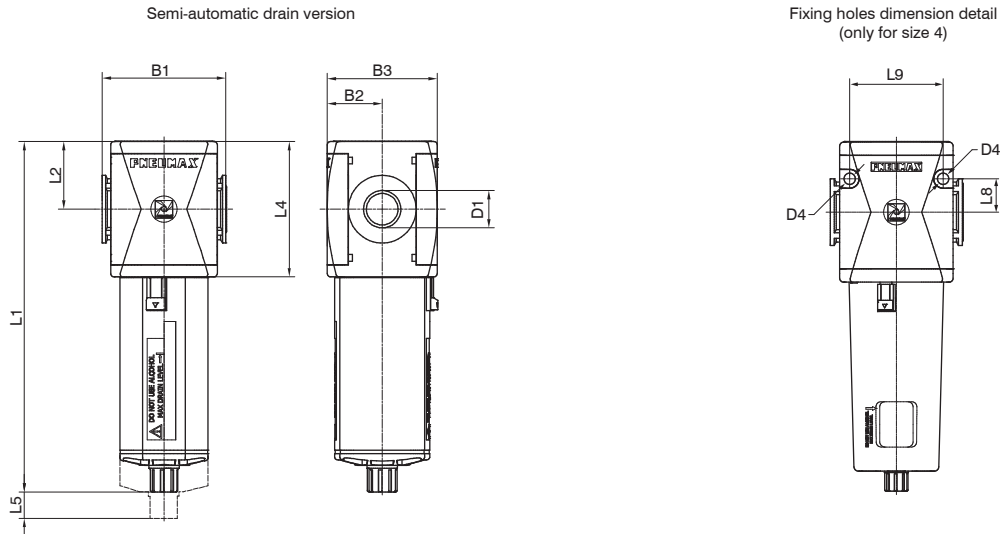

2 AIR TREATMENT

Model	B1	B2	B3	D1	D4	L1 - Bowl material		L2	L4	L5	L8	L9
						Technopolymer	Metal					
#173..	73	32,5	65	G3/8" G1/2" 1/2" NPT	/	207,2	209,5	40	80	65	/	/
#174..	99	44	88	G1" 1" NPT	8,5	262	264,5	52,5	105	103	25	70

**Variable dimensions**

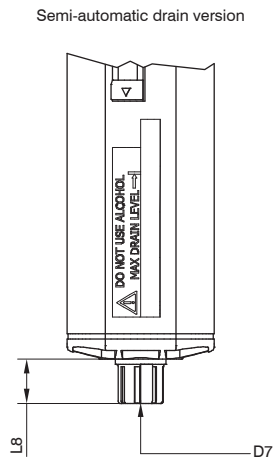

Model	L8 - Bowl material		D7
	Technopolymer	Metal	
Semi-automatic drain	15,7	18	Plastic hose connector

Filter regulators (E - EM - EW - EP - EZ)



- ▶ Filter - diaphragm pressure regulator with relieving
- ▶ Available in 4 sizes with flow rates up to 8000 NI/min and connections from 1/8" to 1"
- ▶ Low hysteresis rolling diaphragm and balanced spool
- ▶ Filtering element made of HDPE available in 3 different filtration grades (5µm, 20µm and 50µm)
- ▶ Bowl assembly via bayonet type quick coupling mechanism with safety button
- ▶ Semi-automatic or automatic drain
- ▶ Available in four pressure ranges up to 12 bar
- ▶ Fitted with panel mounting locking ring
- ▶ Available with pressure gauge or digital pressure switch integrated
- ▶ Atex certification (II 2GD or II 3GD)
- ▶ Inlet pressures up to 20 bar

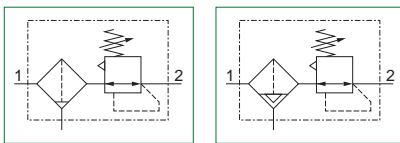

**Note**

For installations where a more accurate and constant pressure is required, the unit should be installed as close as possible to the point of use. In order to ensure that any fluid discharged by the auto drain assembly is adequately drained away, it is recommended you use a 6mm fitting and tube.

Technical characteristics		Size	Size 1	Size 2	Size 3	Size 4
<b>Body and connections type</b>			Technopolymer body, integrated technopolymer connections (T version) Technopolymer body, metal connections (N version)	Aluminium body, integrated aluminium connections (P - L versions)		/
<b>Protection and bowl type</b>			Technopolymer protection - PC bowl Technopolymer protection - PA bowl	Metal protection - PC bowl Metal protection - PA bowl Metal bowl (blind metal bowl)		
<b>IN / OUT connections</b>	<b>T version</b>		G1/4"	G3/8"	G1/2"	not available
	<b>N version</b>		G1/8" - G1/4" - 1/4" NPT	G3/8" - G1/4" - 3/8" NPT	G3/8" - G1/2" - 1/2" NPT	
	<b>P and L version</b>		not available	G3/8" - 1/4" NPT	G1/2" - 1/2" NPT	G1" - 1" NPT
<b>Assembly configuration</b>			Stand alone Panel mounting With fixing bracket /			Panel mounted
<b>Assembly positions</b>			Vertical ±5°			
<b>Filter pore size</b>			5 µm 20 µm 50 µm			
<b>Pressure range</b>			0-2 bar 0-4 bar 0-8 bar 0-12 bar (P2 max 10 Bar in case of digital pressure switch selection)			
<b>Bowl capacity</b>			18 cm <sup>3</sup>	34 cm <sup>3</sup>	68 cm <sup>3</sup>	90 cm <sup>3</sup>
<b>Condensation drain</b>			Semi-automatic Automatic			
<b>Regulation</b>			Manul push and lock with pressure Manual lockable with accessories			
<b>Pressure measurement</b>			G1/8" - 1/8" NPT pressure gauge connection port (only for versions with IN / OUT NPT connections) Integrated pressure gauge (optional) Digital pressure switch (optional)			
<b>Max. fittings torque IN / OUT connections</b>			G1/8" metal: 15Nm G1/4" metal: 20Nm G1/4" technopolymer: 9Nm	G1/4" metal: 20Nm G3/8" metal: 25Nm G3/8" technopolymer: 16Nm	G3/8" metal: 25Nm G1/2" metal: 30Nm G1/2" technopolymer: 22Nm	G1" metal: 35Nm
<b>Max. fitting torque pressure gauge connection port</b>			G1/8" technopolymer: 4Nm G1/8" metal: 15Nm			

Operational characteristics								
Size	Size 1	Size 2	Size 3	Size 4	Size 1	Size 2	Size 3	Size 4
Condensation drain	Semi-automatic				Automatic			
<b>Maximum working pressure</b>	13 bar	20 bar (only with body and metal bowl)			10 bar	16 bar (only with body and metal bowl)		
<b>Minimum working pressure</b>	0,5 bar				0,5 bar			
<b>Working temperature</b>	-5°C +50°C		-30°C +80°C (only for P version and metal bowl) -40°C +80°C (only for L version and metal bowl)		-5°C +50°C			
<b>Working temperature with digital pressure switch</b>	0°C +50°C							

Weights					
	Size	Size 1	Size 2	Size 3	Size 4
Fully technopolymer version		210 g	410 g	500 g	/
Technopolymer body version, aluminium bowl protection and technopolymer bowl		/	440 g	600 g	/
Technopolymer body version, aluminium bowl		/	460 g	660 g	/
Aluminium body version, technopolymer protection and bowl		/	480 g	710 g	1460 g
Aluminium body version, aluminium bowl protection and technopolymer bowl		/	510 g	730 g	1600 g
Aluminium body version and aluminium bowl		/	560 g	790 g	1620 g

**Materials**

Exploded sectioned

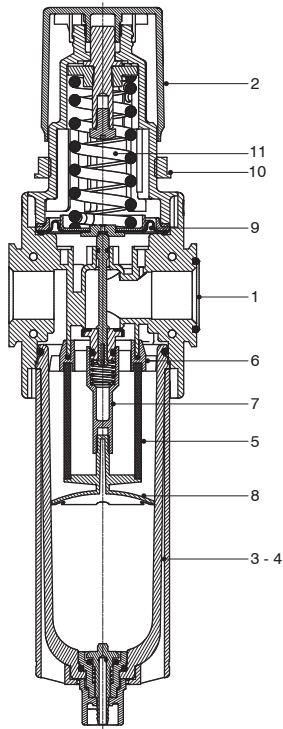

Filter regulator		
1	Body	Polyamide Die-cast aluminium
2	Adjusting knob	Polyamide
3	Technopolymer bowl	Polycarbonate Polyamide
4	Metal bowl Bowl protection	Die-cast aluminium Polyamide - Die-cast aluminium
5	Filtering element	Polyethylene
6	Baffle	Acetal resin
7	Spool support	Acetal resin
8	Filtering element support	Acetal resin
9	Diaphragm	NBR
10	Panel mounting locking ring	Polyamide
11	Adjusting spring	Steel

2  
AIR TREATMENT

**Design**

**Size 1 - Size 2 - Size 3**  
Technopolymer protection

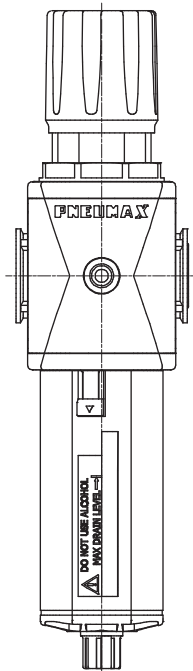

**Size 1 - Size 2 - Size 3**  
Protection / Metal bowl

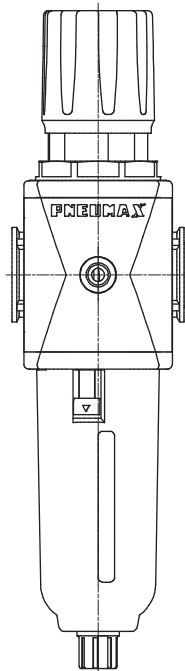

**Size 4**  
All versions

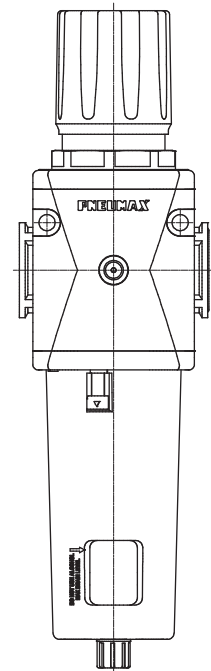





Order codes

	T	17	3B	E	M	B	D	S					T
<b>Version</b>													
N : Technopolymer body and metal inserts (not available for size 4)													
T : Technopolymer body and thread (not available for size 4)													
P : Aluminum body (not available for size 1)													
L : Aluminum body, low temperature (not available for size 1)													
<b>Size and connections</b>													
1A : Size 1 - G1/8" only for N version													
1B : Size 1 - G1/4" only for T - N versions													
1C : Size 1 - 1/4" NPT only for N version													
2A : Size 2 - G1/4" only for N version													
2B : Size 2 - G3/8" for all versions													
2C : Size 2 - 3/8" NPT only for N version - 1/4" NPT only for P - L versions													
3A : Size 3 - G3/8" only for N version													
3B : Size 3 - G1/2" for all versions													
3C : Size 3 - 1/2" NPT only for N - P - L versions													
4B : Size 4 - G1" only for P - L versions													
4C : Size 4 - 1" NPT only for P - L versions													
<b>Pressure measurement options</b>													
: G1/8" - 1/8" NPT thread													
M : Integrated pressure gauge													
W : Integrated pressure gauge Right - Left													
P : Digital pressure switch													
Z : Digital pressure switch Right - Left													
<b>Filter pore size</b>													
A : 5 µm													
B : 20 µm													
C : 50 µm													
<b>Pressure range</b>													
A : 0 - 2 bar													
B : 0 - 4 bar													
C : 0 - 8 bar													
D : 0 - 12 bar													
<b>Condensation drain</b>													
: Semi-automatic drain													
S : Automatic drain													
<b>Relieving options</b>													
: With relieving													
L : Without relieving													
<b>Knob options</b>													
: Non-lockable version													
K : Lockable version													
U : Lockable version with universal key													
<b>Digital pressure switch options</b>													
A : Cable 150 mm + M8 PNP													
B : Cable 150 mm + M8 NPN													
C : Cable 2 m PNP													
D : Cable 2 m NPN													
<b>Bowl options</b>													
: Technopolymer protection - PC bowl													
N : Technopolymer protection - PA bowl													
P : Metal protection - PC bowl (not available for size 1)													
R : Metal protection - PA bowl (not available for size 1)													
T : Metal bowl (not available for size 1)													

**Example : T173BEMBDST** : Size 3 filter regulator G1/2" 20 µm 0 - 12 bar, automatic drain and metal bowl

2  
AIR TREATMENT



**Characteristic curves**

**AIR TREATMENT**

**2**

**Size 1 - G1/4" 0-8 bar P1=7 bar**

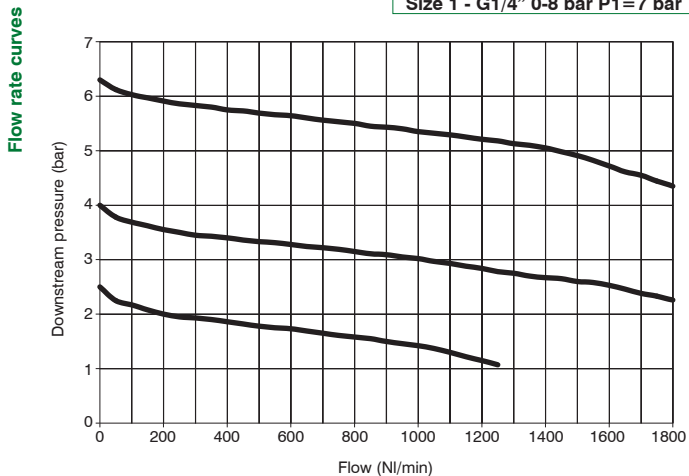

**Adjustment characteristic**

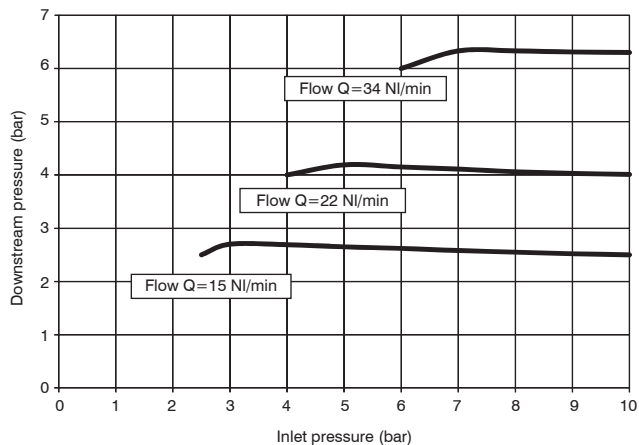

**Size 2 - G3/8" 0-8 bar P1=7 bar**

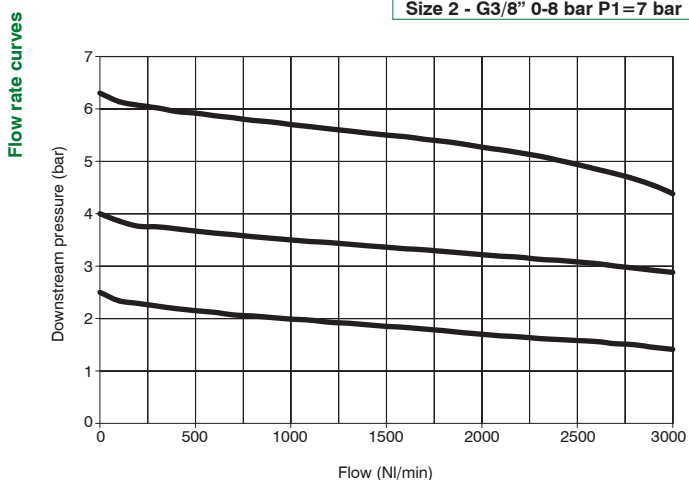

**Adjustment characteristic**

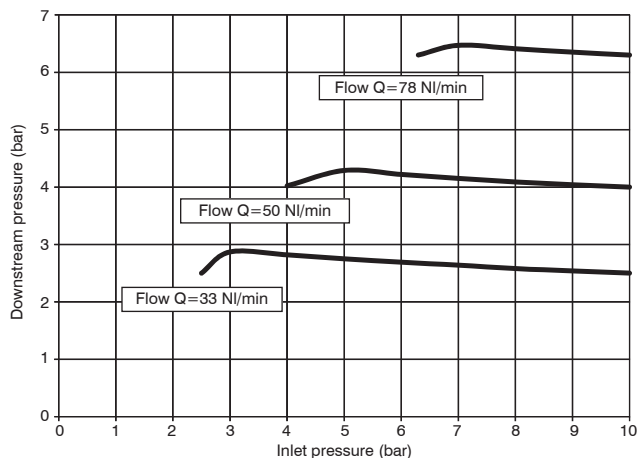

**Size 3 - G1/2" 0-8 bar P1=7 bar**

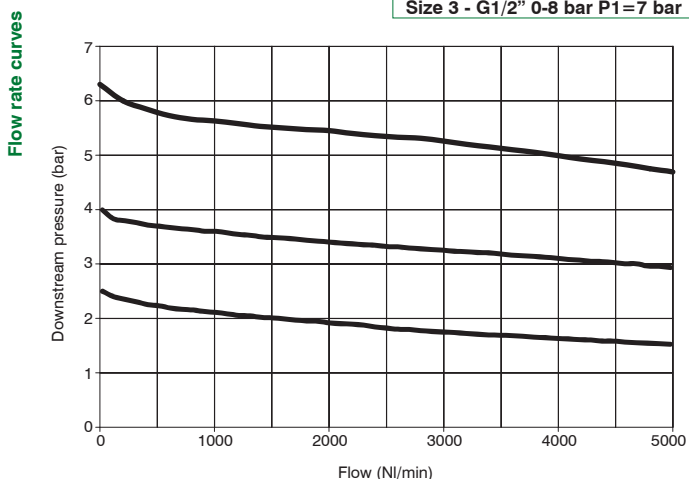

**Adjustment characteristic**

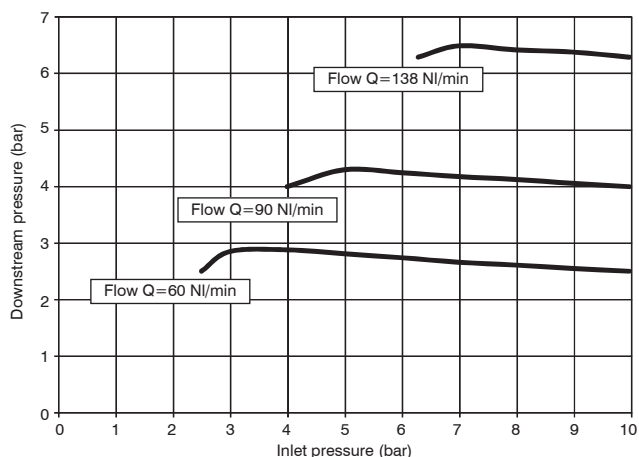

**Size 4 - G1" 0-8 bar P1=10 bar**

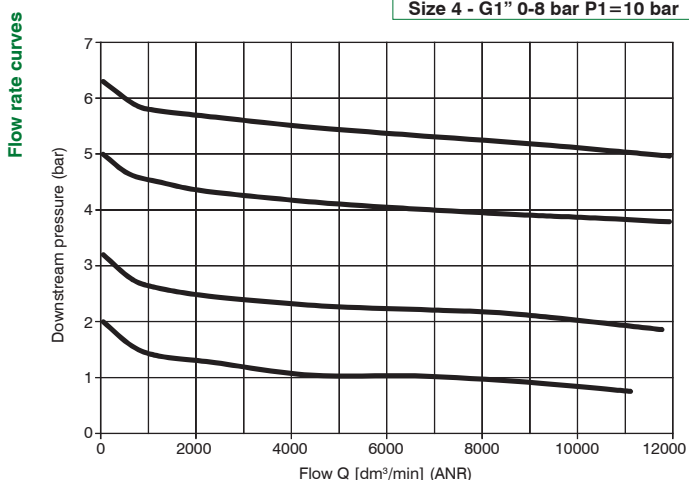

**Adjustment characteristic**

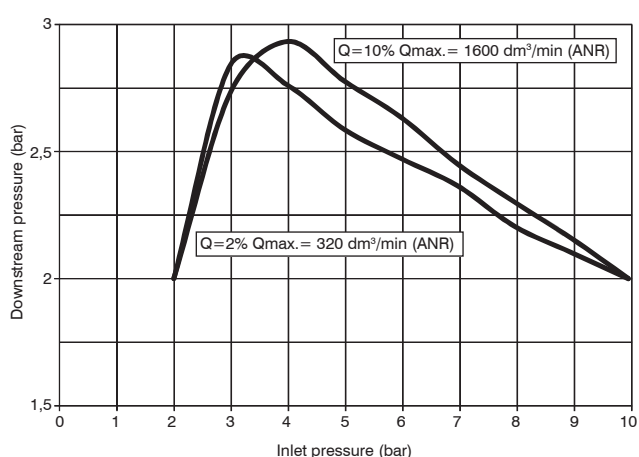

Dimensions

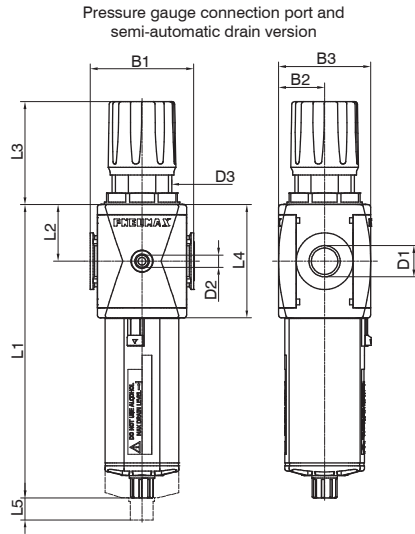

Fixing holes dimension detail (only for size 4)

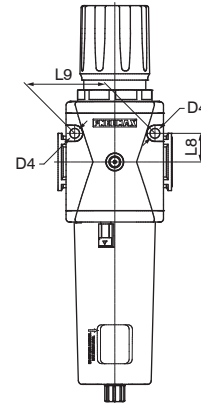

Model	B1	B2	B3	D1	D2	D3	D4	L1 - Bowl material		L2	L3	L4	L5	L8	L9
								Technopolymer	Metal						
#171..	48	21	42	G1/8" G1/4" 1/4" NPT	G1/8" 1/8" NPT	M30x1,5	/	148	/	27,5	54	55	40	/	/
#172..	62	28,5	57	G1/4" G3/8" 1/4" NPT 3/8" NPT	G1/8" 1/8" NPT	M42x1,5	/	169,1	171,5	34	71,8	68	50	/	/
#173..	73	32,5	65	G3/8" G1/2" 1/2" NPT	G1/8" 1/8" NPT	M42x1,5	/	207,2	209,5	40	72,8	80	65	/	/
#174..	99	44	88	G1" 1" NPT	G1/8" 1/8" NPT	M54x1,5	8,5	262	264,5	52,5	87,5	105	103	25	70

2

AIR TREATMENT

Variable dimensions

Integrated pressure gauge version

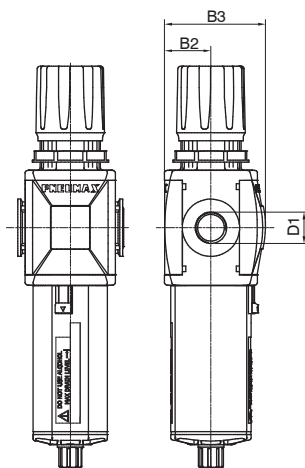

Integrated digital pressure switch version

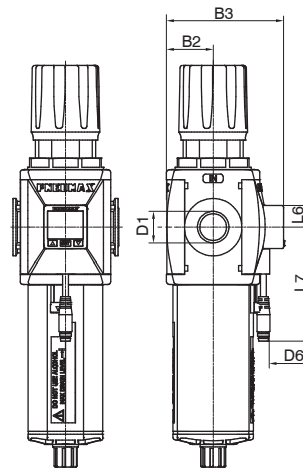

Model	B2	B3		D1	D6 - Type of digital pressure switch		L6	L7 - Type of digital pressure switch	
		With pressure gauge	With digital pressure switch		A - B	C - D		A - B	C - D
#171..	21	48,5	60	G1/8" G1/4" 1/4" NPT	M8 - 3 PIN	3 x 0,129 mm, Ø4 mm	15	150	2000
#172..	28,5	62,5	73,5	G1/4" G3/8" 1/4" NPT 3/8" NPT					
#173..	32,5	70,5	81,5	G3/8" G1/2" 1/2" NPT					
#174..	44	90,5	101,5	G1" 1" NPT					

Variable dimensions

Semi-automatic drain version

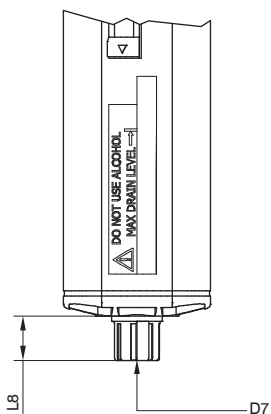

Automatic drain version

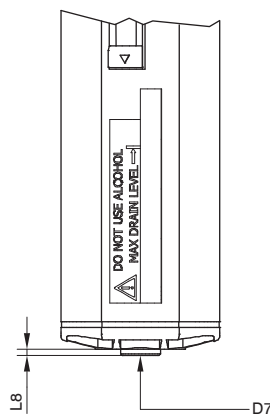

2

AIR TREATMENT

Model	L8 - Bowl material		D7
	Technopolymer	Metal	
Semi-automatic drain	15,7	18	Plastic hose connector
Automatic drain	2	4,5	G1/8"

**Digital pressure switch**



- ▶ 3 color digital LCD display, easy readout
- ▶ 4 units of measurement for pressure indication
- ▶ Optional PNP or NPN digital output
- ▶ N.O. and N.C. output contact selection directly on the digital pressure switch
- ▶ Available with M8-3PIN connector or 3 wire cable length 2 m
- ▶ Available only in combination with a filter regulator

**Output circuit wiring diagrams**

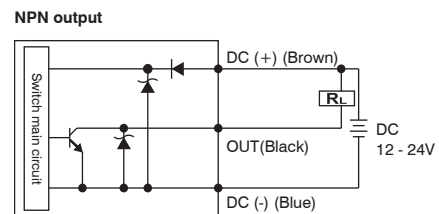
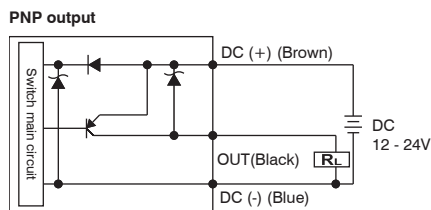

**Digital pressure switch lay out**

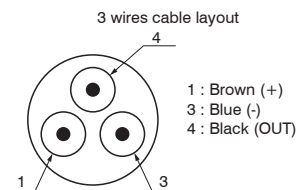
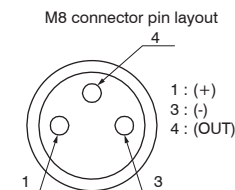

**Cable ordering code**

- MCH1** : cable 3 wires l=2,5m with M8 connector
- MCH2** : cable 3 wires l=5m with M8 connector
- MCH3** : cable 3 wires l=10m with M8 connector



Technical characteristics	
Pressure range and display	0 - 10 bar
Max. inlet pressure	15 bar
Fluid	40µm filtered and dehumidified air
Display unit of measurement	MPa - kgf/cm² - bar - psi
Supply voltage	12 - 24 VDC
Current consumption	≤40mA (without load)
Digital output type	PNP - NPN
Type of contact output	Normally Open - Normally Closed
Max. load current	125 mA
Digital output activation mode	single threshold with fixed hysteresis - window with fixed hysteresis - window without hysteresis
Digital output activation time	0.05s - 0.25s - 0.5s - 1s - 2s - 3s (selections for chattering-proof options)
Display characteristics	Double 3 1/2 digit display Digital output status indication Three-pushbuttons touchpad
Indicator accuracy	≤ ±2% full scale value ± 1 digit
IP Rating	IP40
Working temperature	0°C +50°C
Cable section	3 x 0,129mm², Ø4 mm, PVC

► **Fixing bracket**

T172 50

Size
171 : Size 1
T172 : Size 2 - Size 3

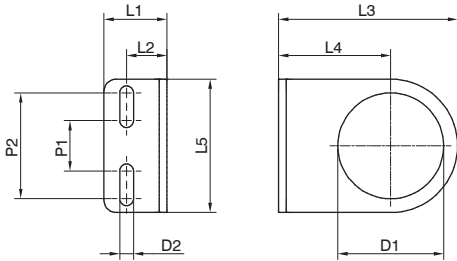

2

AIR TREATMENT

Model	L1	L2	L3	L4	L5	D1	D2	P1	P2
17150	20	13	50	30	40	30	5,5	20	30
T17250	25	16	71	44,5	53	42	5,5	20	42

► **Pressure gauge**

17070 A C

Version
A : Dial Ø40
B : Dial Ø50

Scale
A : 0 - 4 bar
B : 0 - 6 bar
C : 0 - 12 bar

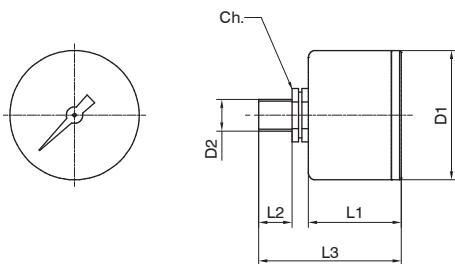

Model	L1	L2	L3	D1	D2	Ch
17070A..	26	10	44	41	Gc - 1/8"	14
17070B..	27	10	45	49	Gc - 1/8"	14

► Regulators (R - RM - RW - RP - RZ)



- ▶ Diaphragm pressure regulator with relieving
- ▶ Available in 4 sizes with flow rates up to 8000 NI/min and connections from 1/8" to 1"
- ▶ Low hysteresis rolling diaphragm and balanced spool
- ▶ Available in four pressure ranges up to 12 bar
- ▶ Fitted with panel mounting locking ring
- ▶ Available with pressure gauge or digital pressure switch integrated
- ▶ Atex certification (II 2GD or II 3GD)
- ▶ Inlet pressures up to 20 bar

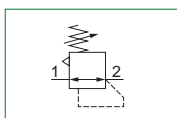

**Note**

For installations where a more accurate and constant pressure is required, the unit should be installed as close as possible to the point of use.

2

AIR TREATMENT

Technical characteristics		Size	Size 1	Size 2	Size 3	Size 4
<b>Body and connections type</b>		Technopolymer body, integrated technopolymer connections (T version) Technopolymer body, metal connections (N version)				/
		/		Aluminium body, integrated aluminium connections (P - L versions)		
<b>IN / OUT connections</b>	<b>T version</b>	G1/4"		G3/8"		G1/2"
	<b>N version</b>	G1/8" - G1/4" - 1/4" NPT		G3/8" - G1/4" - 3/8" NPT		G3/8" - G1/2" - 1/2" NPT
	<b>P and L version</b>	not available		G3/8" - 1/4" NPT		G1/2" - 1/2" NPT
<b>Assembly configuration</b>		Stand alone Panel mounting With fixing bracket /				Panel mounted
<b>Assembly positions</b>		Indifferent				
<b>Pressure range</b>		0-2 bar 0-4 bar 0-8 bar 0-12 bar (P2 max 10 Bar in case of digital pressure switch selection)				
<b>Regulation</b>		Manul push and lock with pressure Manual lockable with accessories				
<b>Pressure measurement</b>		G1/8" - 1/8" NPT pressure gauge connection port (only for versions with IN / OUT NPT connections) Integrated pressure gauge (optional) Digital pressure switch (optional)				
<b>Max. fittings torque IN / OUT connections</b>		G1/8" metal: 15Nm G1/4" metal: 20Nm G1/4" technopolymer: 9Nm		G1/4" metal: 20Nm G3/8" metal: 25Nm G3/8" technopolymer: 16Nm		G3/8" metal: 25Nm G1/2" metal: 30Nm G1/2" technopolymer: 22Nm G1" metal: 35Nm
<b>Max. fitting torque pressure gauge connection port</b>		G1/8" technopolymer: 4Nm G1/8" metal: 15Nm				

Operational characteristics		Size	Size 1	Size 2	Size 3	Size 4
<b>Maximum working pressure</b>		13 bar		20 bar (only for P - L versions)		
<b>Minimum working pressure</b>		0,5 bar				
<b>Working temperature</b>		-5°C +50°C		-30°C +80°C (only for P version) -40°C +80°C (only for L version)		
<b>Working temperature with digital pressure switch</b>		0°C +50°C				



Weights					
	Size	Size 1	Size 2	Size 3	Size 4
Technopolymer body version		150 g	310 g	390 g	/
Aluminium body version		/	400 g	560 g	1260 g

**Materials**

Exploded sectioned

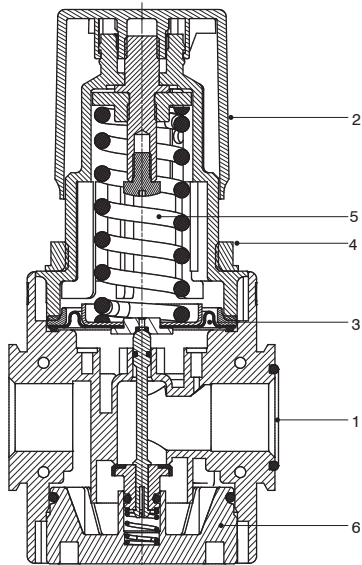

Regulator		
1	Body	Polyamide Die-cast aluminium
2	Adjusting knob	Polyamide
3	Diaphragm	NBR
4	Panel mounting locking ring	Polyamide
5	Adjusting spring	Steel
6	Rear end cap	Polyamide / Die-cast aluminium

2

AIR TREATMENT

**Design**

Size 1 - Size 2 - Size 3

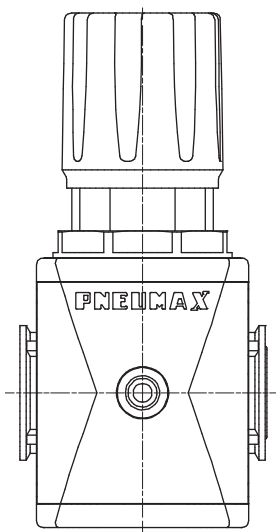

Size 4  
All versions

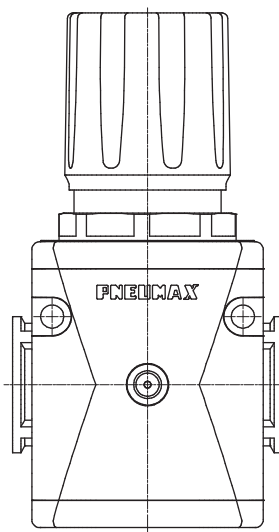





Order codes

T 17 3B R M D [ ] [ ] [ ]

Version
N : Technopolymer body and metal inserts (not available for size 4)
T : Technopolymer body and thread (not available for size 4)
P : Aluminum body (not available for size 1)
L : Aluminum body, low temperature (not available for size 1)

Size and connections
1A : Size 1 - G1/8" only for N version
1B : Size 1 - G1/4" only for T - N versions
1C : Size 1 - 1/4" NPT only for N version
2A : Size 2 - G1/4" only for N version
2B : Size 2 - G3/8" for all versions
2C : Size 2 - 3/8" NPT only for N version - 1/4" NPT only for P - L versions
3A : Size 3 - G3/8" only for N version
3B : Size 3 - G1/2" for all versions
3C : Size 3 - 1/2" NPT only for N - P - L versions
4B : Size 4 - G1" only for P - L versions
4C : Size 4 - 1" NPT only for P - L versions

Pressure measurement options
: G1/8" - 1/8" NPT thread
M : Integrated pressure gauge
W : Integrated pressure gauge Right - Left
P : Digital pressure switch
Z : Digital pressure switch Right - Left

Pressure range
A : 0 - 2 bar
B : 0 - 4 bar
C : 0 - 8 bar
D : 0 - 12 bar

Relieving options
: With relieving
F : Controlled refiel and improved relieving (not available for size 4)
L : Without relieving
R : Improved relieving

Knob options
: Non-lockable version
K : Lockable version
U : Lockable version with universal key

Digital pressure switch options
A : Cable 150 mm + M8 PNP
B : Cable 150 mm + M8 NPN
C : Cable 2 m PNP
D : Cable 2 m NPN

Example : T173BRMD : Size 3 regulator G1/2" 0 - 12 bar



**Characteristic curves**

**AIR TREATMENT**

**2**

**Size 1 - G1/4" 0-8 bar P1=7 bar**

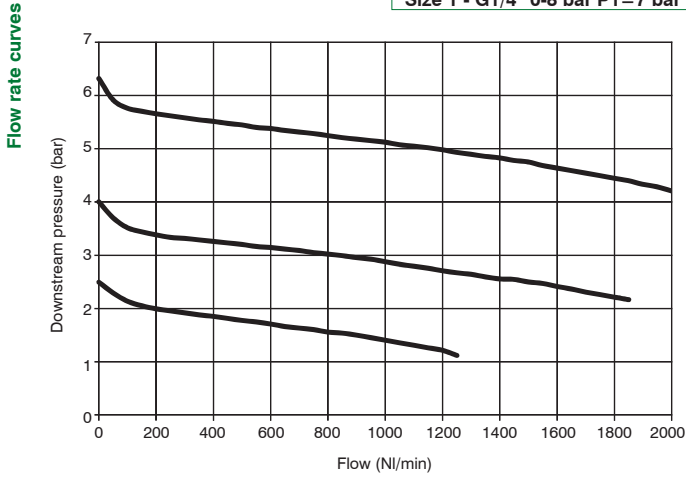

**Adjustment characteristic**

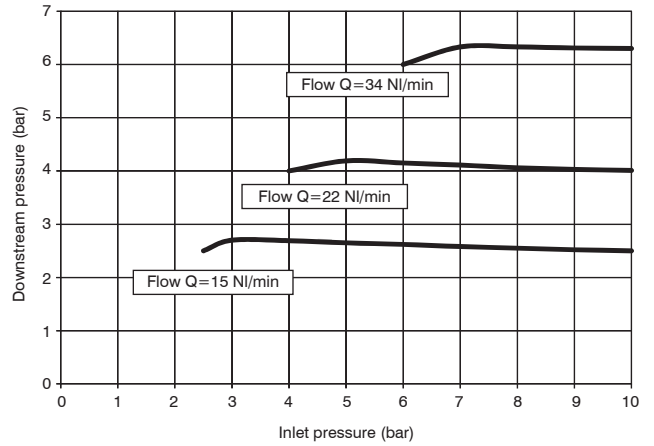

**Size 2 - G3/8" 0-8 bar P1=7 bar**

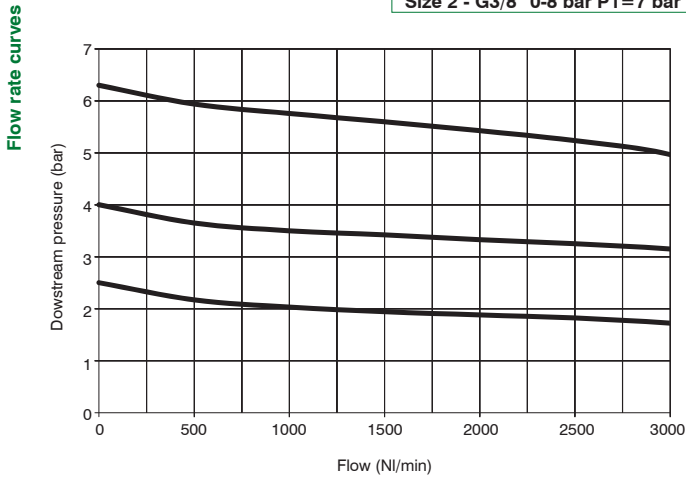

**Adjustment characteristic**

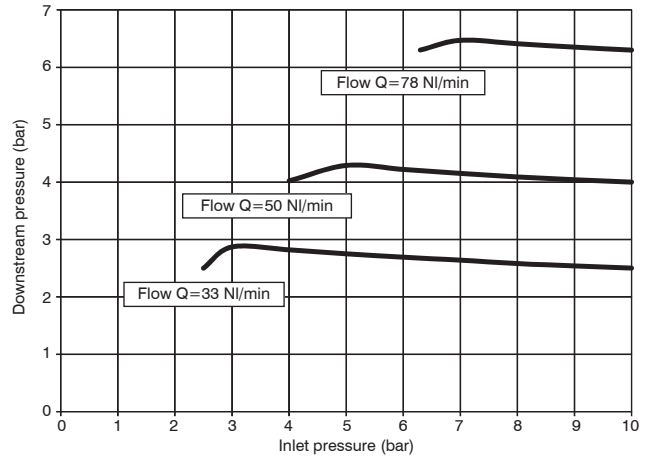

**Size 3 - G1/2" 0-8 bar P1=7 bar**

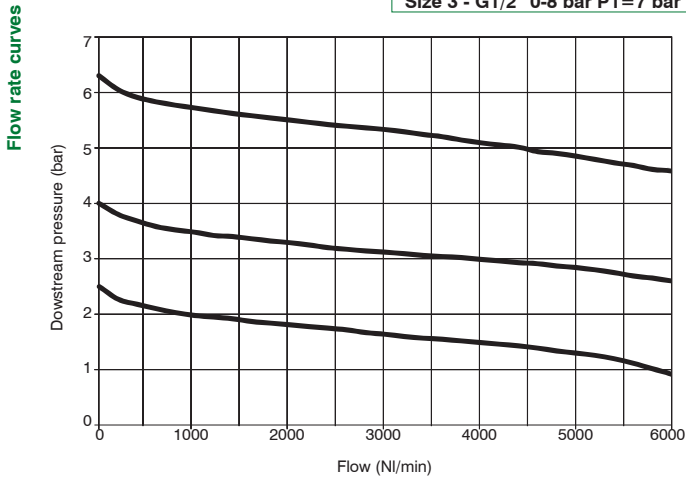

**Adjustment characteristic**

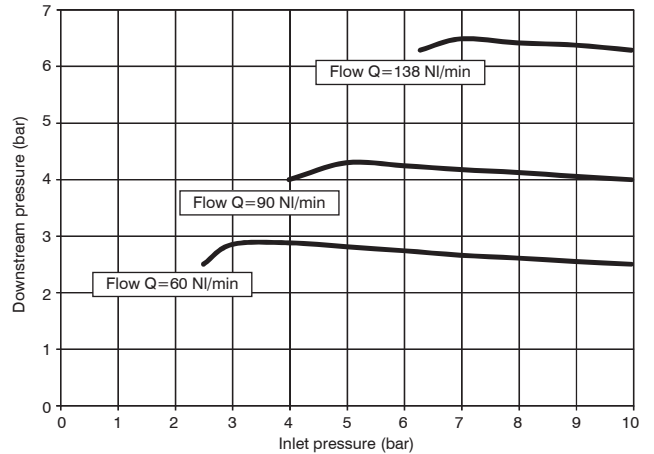

**Size 4 - G1" 0-8 bar P1=10 bar**

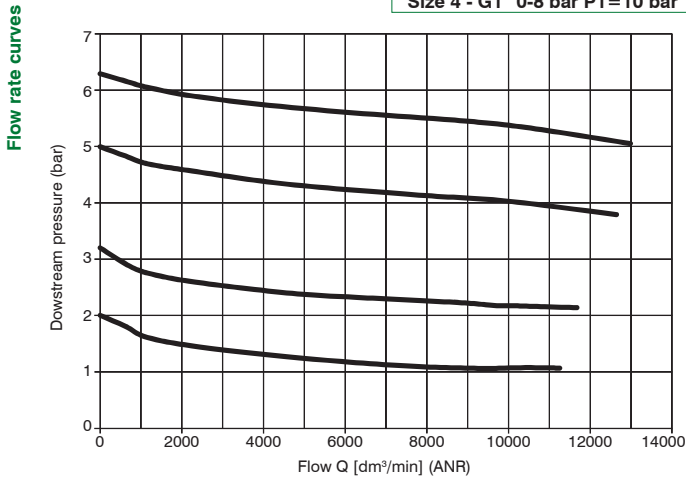

**Adjustment characteristic**

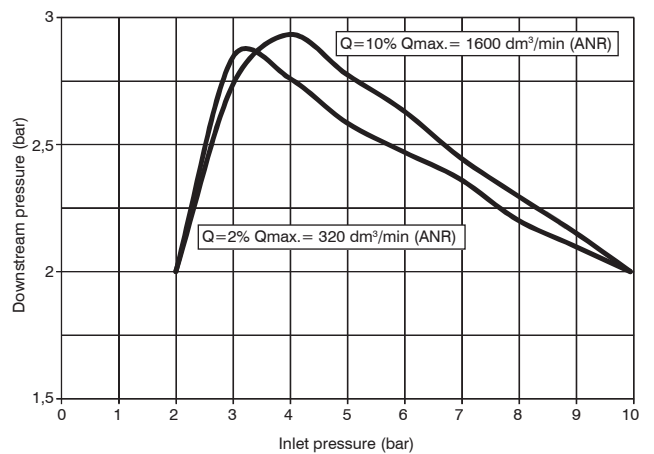

Dimensions

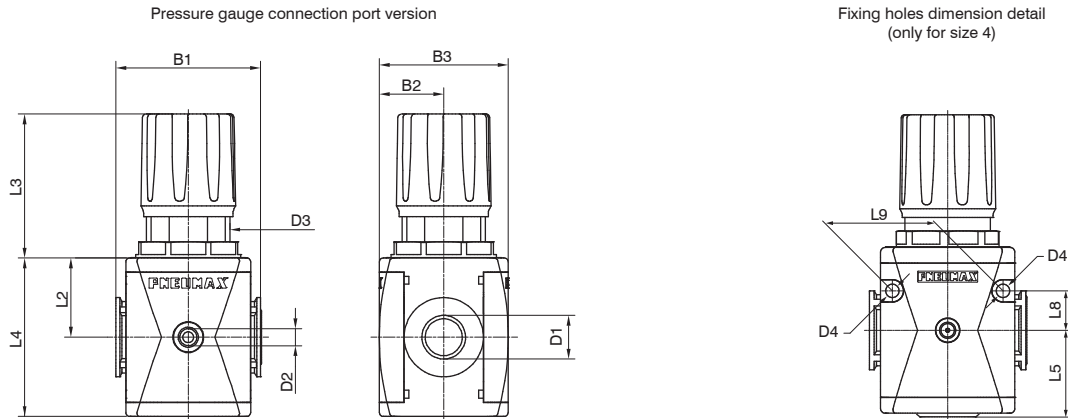

Model	B1	B2	B3	D1	D2	D3	D4	L2	L3	L4	L5	L8	L9
#171..	48	21	42	G1/8" G1/4" 1/4" NPT	G1/8" 1/8" NPT	M30x1,5	/	27,5	54	55	/	/	/
#172..	62	28,5	57	G1/4" G3/8" 1/4" NPT 3/8" NPT	G1/8" 1/8" NPT	M42x1,5	/	34	71,8	68	/	/	/
#173..	73	32,5	65	G3/8" G1/2" 1/2" NPT	G1/8" 1/8" NPT	M42x1,5	/	40	72,8	80	/	/	/
#174..	99	44	88	G1" 1" NPT	G1/8" 1/8" NPT	M54x1,5	8,5	52,5	87,5	105	54,5	25	70

2

AIR TREATMENT

Variable dimensions

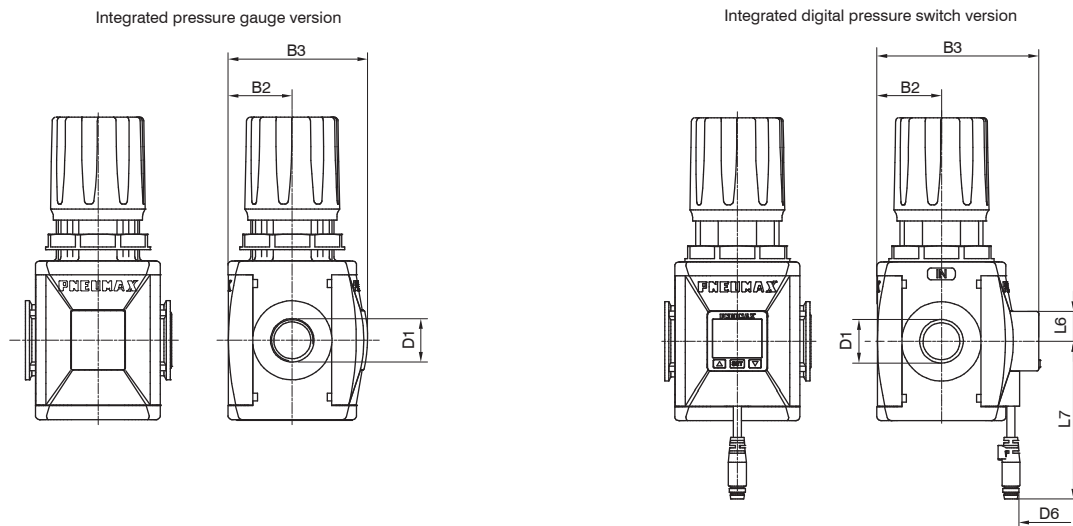

Model	B2	B3		D1	D6 - Type of digital pressure switch		L6	L7 - Type of digital pressure switch	
		With pressure gauge	With digital pressure switch		A - B	C - D		A - B	C - D
#171..	21	48,5	60	G1/8" G1/4" 1/4" NPT	M8 - 3 PIN	3 x 0,129 mm, Ø4 mm	15	150	2000
#172..	28,5	62,5	73,5	G1/4" G3/8" 1/4" NPT 3/8" NPT					
#173..	32,5	70,5	81,5	G3/8" G1/2" 1/2" NPT					
#174..	44	90,5	101,5	G1" 1" NPT					

► **Fixing bracket**

T172 50

Size
171 : Size 1
T172 : Size 2 - Size 3

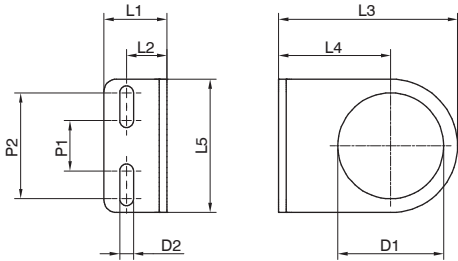

2

AIR TREATMENT

Model	L1	L2	L3	L4	L5	D1	D2	P1	P2
17150	20	13	50	30	40	30	5,5	20	30
T17250	25	16	71	44,5	53	42	5,5	20	42

► **Pressure gauge**

17070 A C

Version
A : Dial Ø40
B : Dial Ø50

Scale
A : 0 - 4 bar
B : 0 - 6 bar
C : 0 - 12 bar

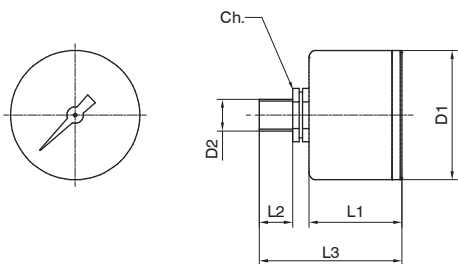

Model	L1	L2	L3	D1	D2	Ch
17070A..	26	10	44	41	Gc - 1/8"	14
17070B..	27	10	45	49	Gc - 1/8"	14

▶ **Piloted pressure regulators (RP - RMP - RPP)**



- ▶ Piston piloted pressure regulator
- ▶ Available with pressure gauge or digital pressure switch integrated
- ▶ Atex certification (II 2GD or II 3GD)
- ▶ Inlet pressures up to 20 bar

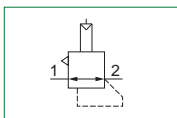

**Note**  
Always regulate the rising pressure.

Technical characteristics	
Size	Size 4
Body and connections type	Aluminium body, integrated aluminium connections
IN / OUT connections	G1" - 1" NPT
Assembly configuration	Stand alone Panel mounted
Assembly positions	Indifferent
Pressure range	0,5 - 10 bar
Regulation	Pneumatic piloting
Pressure measurement	G1/8" - 1/8" NPT pressure gauge connection port (only for versions with IN / OUT NPT connections) Integrated pressure gauge (optional) Digital pressure switch (optional)
Max. fittings torque IN / OUT connections	G1"metal: 35Nm
Max.fitting torque pressure gauge connection port	G1/8"metal: 15Nm

Operational characteristics	
Size	Size 4
Maximum working pressure	20 bar
Minimum working pressure	0,5 bar
Pilot pressure range	0,5 - 10 bar
Working temperature	-30°C +80°C
Working temperature with digital pressure switch	0°C +50°C

2  
AIR TREATMENT



Weights					
	Size	Size 1	Size 2	Size 3	Size 4
Pneumatic pilot aluminum body version		/	/	/	1190 g

**Materials**

Exploded sectioned

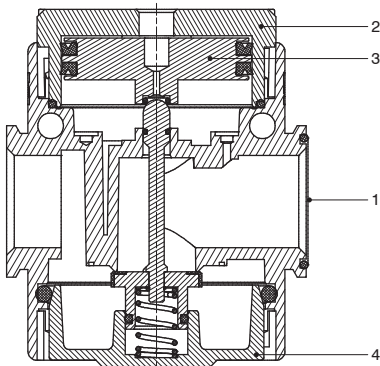

Piloted pressure regulator		
1	Body	Die-cast aluminium
2	Piloting operator	Aluminium
3	Piston	Aluminium
4	Rear end cap	Die-cast aluminium

2

AIR TREATMENT

**Design**

G1/8" pressure gauge connection port version

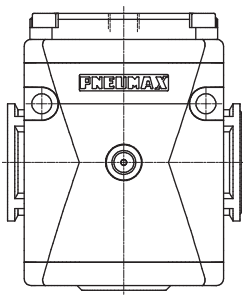

Integrated pressure gauge version

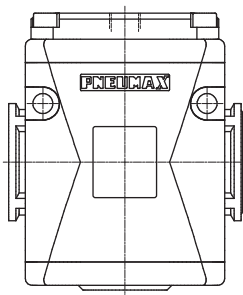

Integrated digital pressure switch version

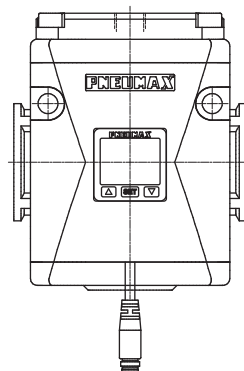

**Order codes**

P 17 4B R M P

<b>Version</b>	P : Aluminium body
<b>Size and connections</b>	4B : Size 4 - G1" 4C : Size 4 - 1" NPT
<b>Pressure measurement options</b>	: G1/8" - 1/8" NPT thread M : Integrated pressure gauge W : Integrated pressure gauge Right - Left P : Digital pressure switch Z : Digital pressure switch Right - Left
<b>Digital pressure switch options</b>	A : Cable 150 mm + M8 PNP B : Cable 150 mm + M8 NPN C : Cable 2 m PNP D : Cable 2 m NPN

**Example : P174BRMP** : Size 4 piloted pressure regulator G1", integrated pressure gauge

Characteristic curves

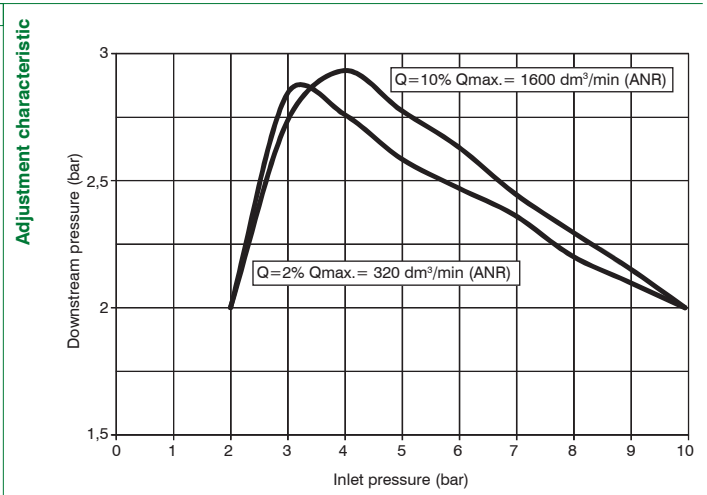
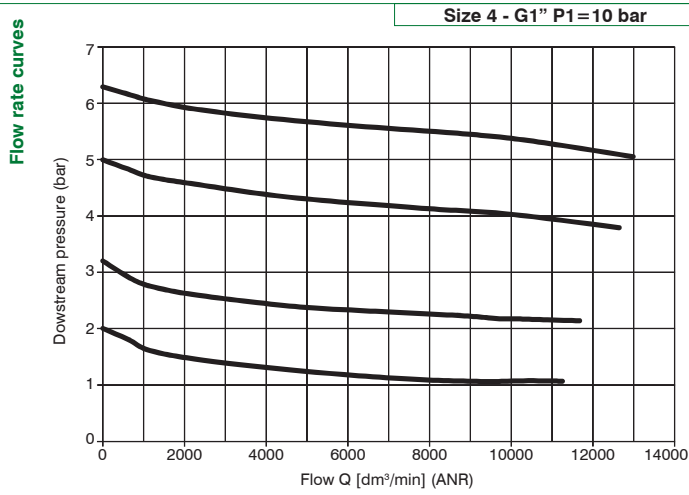

**Piloting curves**

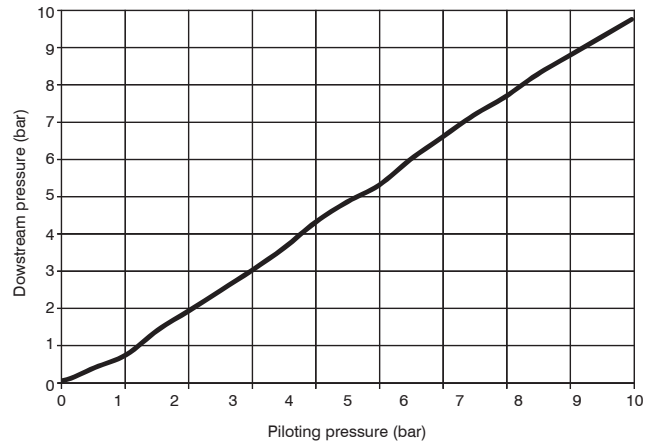

2

AIR TREATMENT



**Dimensions**

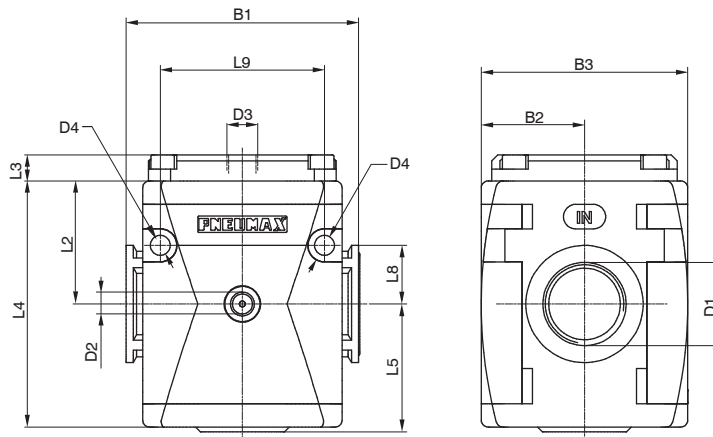

2 AIR TREATMENT

Model	B1	B2	B3	D1	D2	D3	D4	L2	L3	L4	L5	L8	L9
#174..	99	44	88	G1" 1" NPT	G1/8" 1/8" NPT	G1/4"	8,5	52,5	11	105	54,5	25	70

**Variable dimensions**

Integrated pressure gauge version

Integrated digital pressure switch version

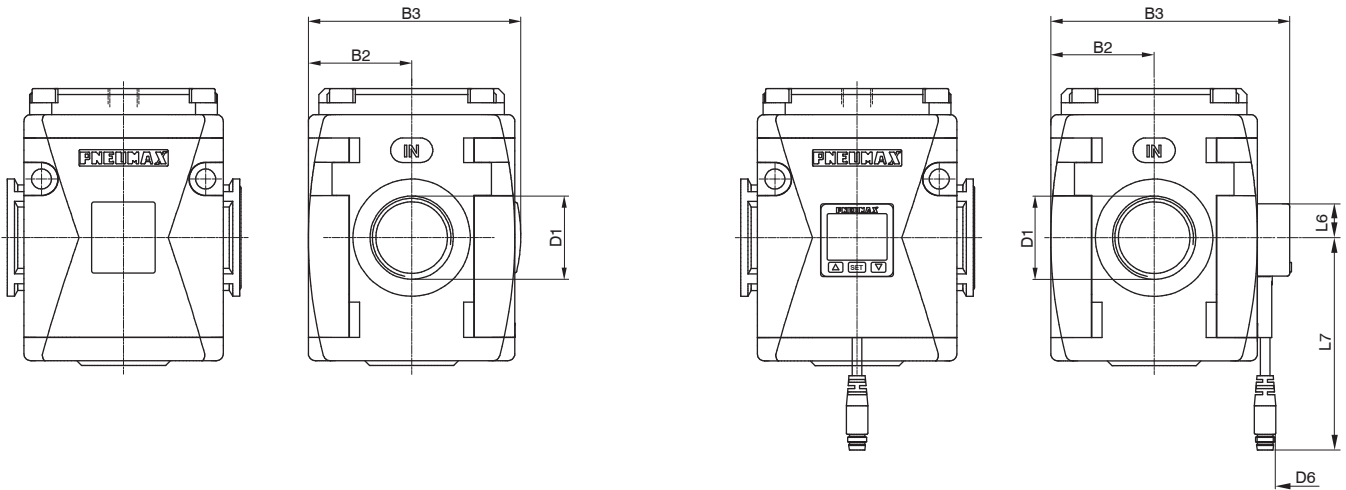

Model	B2	B3		D1	D6 - Type of digital pressure switch		L6	L7 - Type of digital pressure switch	
		With pressure gauge	With digital pressure switch		A - B	C - D		A - B	C - D
#174..	44	90,5	101,5	G1" 1" NPT	M8 - 3 PIN	3 x 0,129 mm, Ø4 mm	15	150	2000



**Digital pressure switch**



- ▶ 3 color digital LCD display, easy readout
- ▶ 4 units of measurement for pressure indication
- ▶ Optional PNP or NPN digital output
- ▶ N.O. and N.C. output contact selection directly on the digital pressure switch
- ▶ Available with M8-3PIN connector or 3 wire cable length 2 m
- ▶ Available only in combination with a regulator

**Output circuit wiring diagrams**

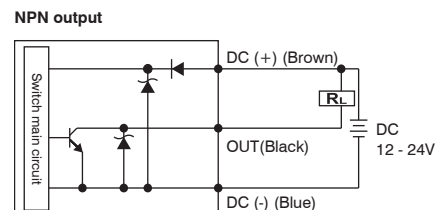
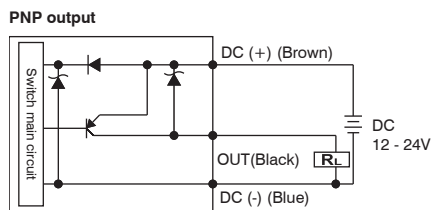

**Digital pressure switch lay out**

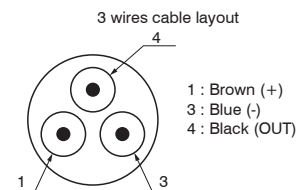
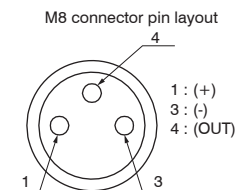

**Cable ordering code**

- MCH1** : cable 3 wires l=2,5m with M8 connector
- MCH2** : cable 3 wires l=5m with M8 connector
- MCH3** : cable 3 wires l=10m with M8 connector



Technical characteristics	
Pressure range and display	0 - 10 bar
Max. inlet pressure	15 bar
Fluid	40µm filtered and dehumidified air
Display unit of measurement	MPa - kgf/cm² - bar - psi
Supply voltage	12 - 24 VDC
Current consumption	≤40mA (without load)
Digital output type	PNP - NPN
Type of contact output	Normally Open - Normally Closed
Max. load current	125 mA
Digital output activation mode	single threshold with fixed hysteresis - window with fixed hysteresis - window without hysteresis
Digital output activation time	0.05s - 0.25s - 0.5s - 1s - 2s - 3s (selections for chattering-proof options)
Display characteristics	Double 3 1/2 digit display Digital output status indication Three-pushbuttons touchpad
Indicator accuracy	≤±2% full scale value ± 1 digit
IP Rating	IP40
Working temperature	0°C +50°C
Cable section	3 x 0,129mm², Ø4 mm, PVC

► Pressure regulators for manifold (B - M)



- ▶ Diaphragm pressure regulator with relieving
- ▶ Available with 2 front outputs connections G1/8 " or with 1 front output and integrated pressure gauge on the opposite side
- ▶ Low hysteresis rolling diaphragm and balanced spool
- ▶ Available in four pressure ranges up to 12 bar
- ▶ Fitted with panel mounting locking ring
- ▶ Available with Integrated pressure gauge
- ▶ Air supply can be applied by both directions (Right or Left)
- ▶ Max. 6off pressure regulators in manifold configuration
- ▶ Atex certification (II 3GD)

2

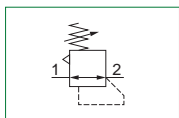

**Note**  
For installations where a more accurate and constant pressure is required, the unit should be installed as close as possible to the point of use.

AIR TREATMENT

Technical characteristics	
Size	Size 1
<b>Body and connections type</b>	Technopolymer body, integrated technopolymer connections (T version) Technopolymer body, metal connections (N version)
<b>IN connections</b>	T version
	N version
<b>OUT connections</b>	
<b>Assembly configuration</b>	
<b>Assembly positions</b>	
<b>Pressure range</b>	
<b>Regulation</b>	
<b>Pressure measurement</b>	
<b>Max. fittings torque IN / OUT connections</b>	
<b>Max.fitting torque pressure gauge connection port</b>	

Operational characteristics	
Size	Size 1
<b>Maximum working pressure</b>	
<b>Minimum working pressure</b>	
<b>Working temperature</b>	

Weights		
	Size	Size 1
Technopolymer body version		140 g

**Materials**

Exploded sectioned

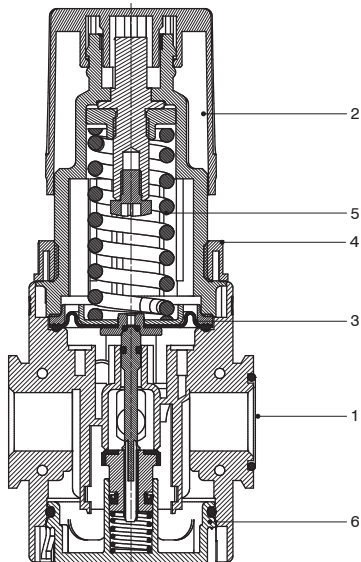

Pressure regulator for manifold

1	Body	Polyamide Die-cast aluminium
2	Adjusting knob	Polyamide
3	Diaphragm	NBR
4	Panel mounting locking ring	Polyamide
5	Adjusting spring	Steel
6	Rear end cap	Polyamide / Die-cast aluminium

2

AIR TREATMENT

**Design**

Pressure gauge connection port version

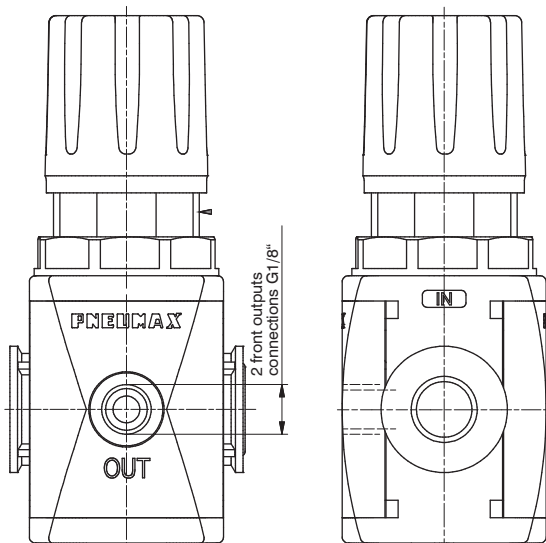

Integrated pressure gauge version

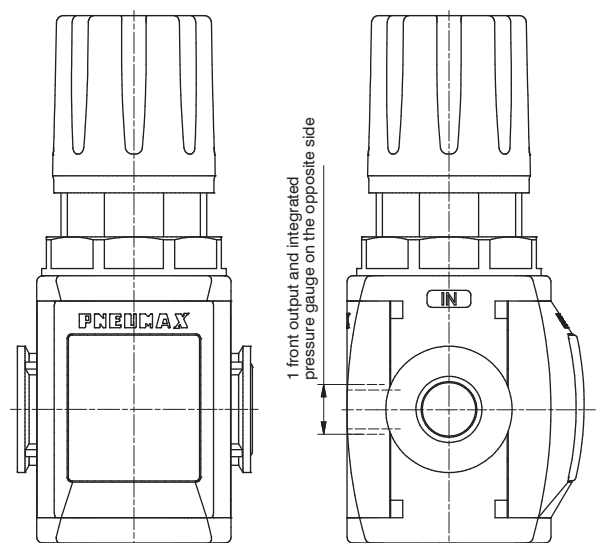



**Order codes**

T 17 1B B D

Version
N : Technopolymer body and metal inserts
T : Technopolymer body and thread

Size and connections
1A : Size 1 - G1/8"
1B : Size 1 - G1/4"
1C : Size 1 - 1/4" NPT only for N version

Pressure measurement options
B : G1/8" - 1/8" NPT thread
M : Integrated pressure gauge

Pressure range
A : 0 - 2 bar
B : 0 - 4 bar
C : 0 - 8 bar
D : 0 - 12 bar

Relieving options
: With relieving
F : Controlled refuel and improved relieving
L : Without relieving
R : Improved relieving

Knob options
: Non-lockable version
K : Lockable version
U : Lockable version with universal key

**Example : T171BBD** : Size 1 pressure regulator for manifold G1/4", 0 - 12 bar

2 AIR TREATMENT

**Characteristic curves**

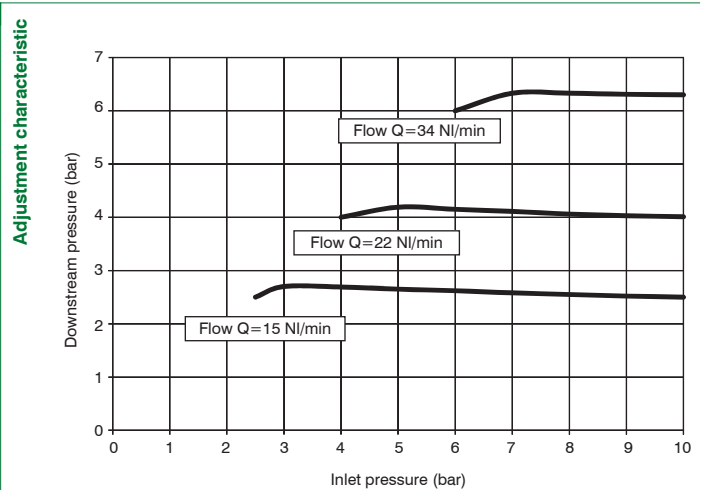
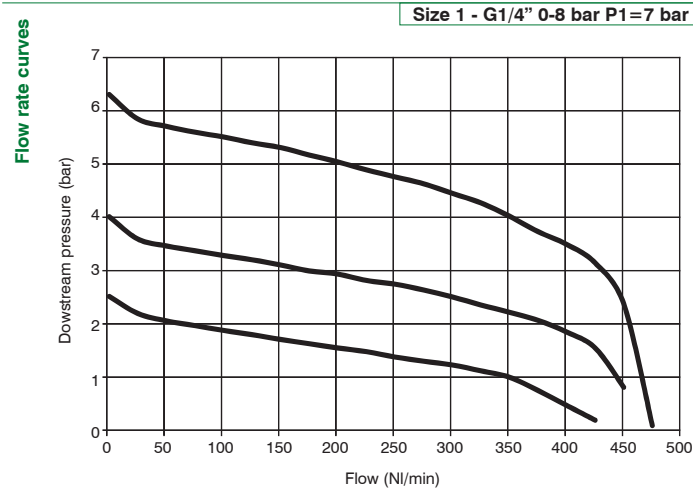

Dimensions

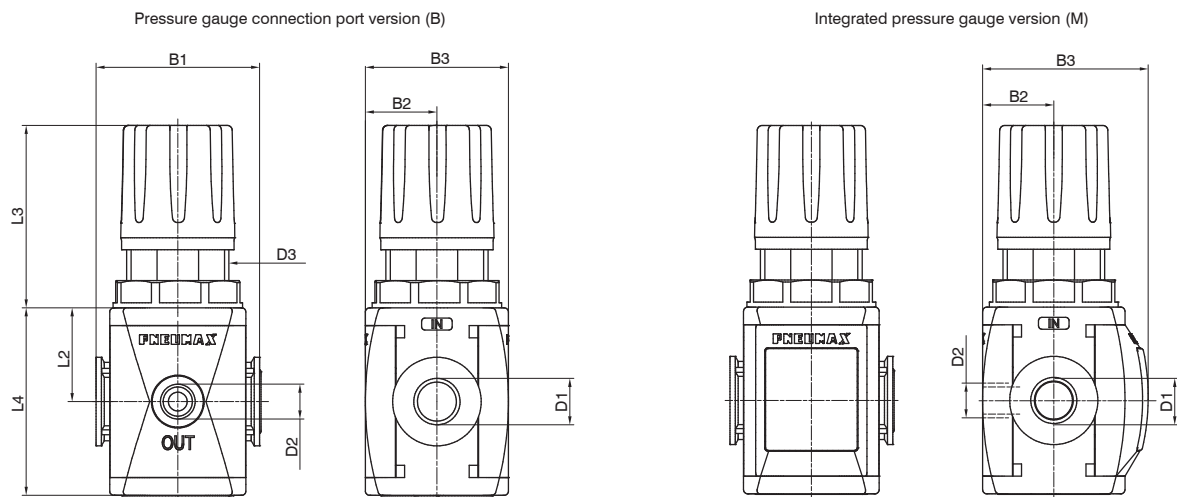

Model	B1	B2	B3		D1	D2	D3	L2	L3	L4
			B version	M version						
#171..	48	24	42	48,5	G1/4" G1/8" 1/4" NPT	G1/8"	M30x1,5	27,5	54	55

▶ **Manifold pressure regulators**



- ▶ Manifold pressure regulators
- ▶ Available in four pressure ranges up to 12 bar
- ▶ Inlet pressure common for the whole manifold of pressure regulator
- ▶ A maximum of 6 pressure regulators can be mounted
- ▶ Atex certification (II 3GD)
- ▶ Assembly with X or Y flanges

2

AIR TREATMENT

Technical characteristics		Size	Size 1
<b>Body and connections type</b>		Technopolymer body, integrated technopolymer connections (T version) Technopolymer body, metal connections (N version)	
<b>IN connections</b>	T version	G1/4"	
	N version	G1/8" - G1/4" - 1/4" NPT	
<b>OUT connections</b>		G1/8"	
<b>Assembly configuration</b>		Stand alone Panel mounting With fixing bracket	
<b>Assembly positions</b>		Indifferent	
<b>Pressure range</b>		0-2 bar 0-4 bar 0-8 bar 0-12 bar	
<b>Regulation</b>		Manul push and lock with pressure Manual lockable with accessories	
<b>Pressure measurement</b>		G1/8" pressure gauge connection port Integrated pressure gauge (optional)	
<b>Max. fittings torque IN / OUT connections</b>		G1/8" metal: 15Nm G1/4" metal: 20Nm G1/4" technopolymer: 9Nm	
<b>Max.fitting torque pressure gauge connection port</b>		G1/8" technopolymer: 4Nm G1/8" metal: 15Nm	

Operational characteristics		Size	Size 1
<b>Maximum working pressure</b>		13 bar	
<b>Minimum working pressure</b>		0,5 bar	
<b>Working temperature</b>		-5°C +50°C	



Order codes

G T 17 1B M 6 C C C C C C

<b>Version</b>
N : Technopolymer body and metal inserts
T : Technopolymer body and thread

<b>Size and connections</b>
1A : Size 1 - G1/8"
1B : Size 1 - G1/4"
1C : Size 1 - 1/4" NPT only for N version

<b>Pressure measurement options</b>
B : G1/8" thread with flanges X
M : Integrated pressure gauge with flanges X
P : G1/8" thread with extended flanges Y
R : Integrated pressure gauge with extended flanges Y
W : G1/8" thread with flanges Y
Z : Integrated pressure gauge with flanges Y

<b>Number of regulators</b>
2 : n. 2 regulators
3 : n. 3 regulators
4 : n. 4 regulators
5 : n. 5 regulators
6 : n. 6 regulators

<b>Pressure range</b>
A : 0 - 2 bar
B : 0 - 4 bar
C : 0 - 8 bar
D : 0 - 12 bar

<b>Pressure range</b>
A : 0 - 2 bar
B : 0 - 4 bar
C : 0 - 8 bar
D : 0 - 12 bar

<b>Pressure range</b>
A : 0 - 2 bar
B : 0 - 4 bar
C : 0 - 8 bar
D : 0 - 12 bar

<b>Pressure range</b>
A : 0 - 2 bar
B : 0 - 4 bar
C : 0 - 8 bar
D : 0 - 12 bar

<b>Pressure range</b>
A : 0 - 2 bar
B : 0 - 4 bar
C : 0 - 8 bar
D : 0 - 12 bar

<b>Pressure range</b>
A : 0 - 2 bar
B : 0 - 4 bar
C : 0 - 8 bar
D : 0 - 12 bar

**Example : T171BM6CCCCC** : Size 1 manifold pressure regulators G1/4", 0 - 8 bar, integrated pressure gauge

2  
AIR TREATMENT

**Dimensions**

**2**  
**AIR TREATMENT**

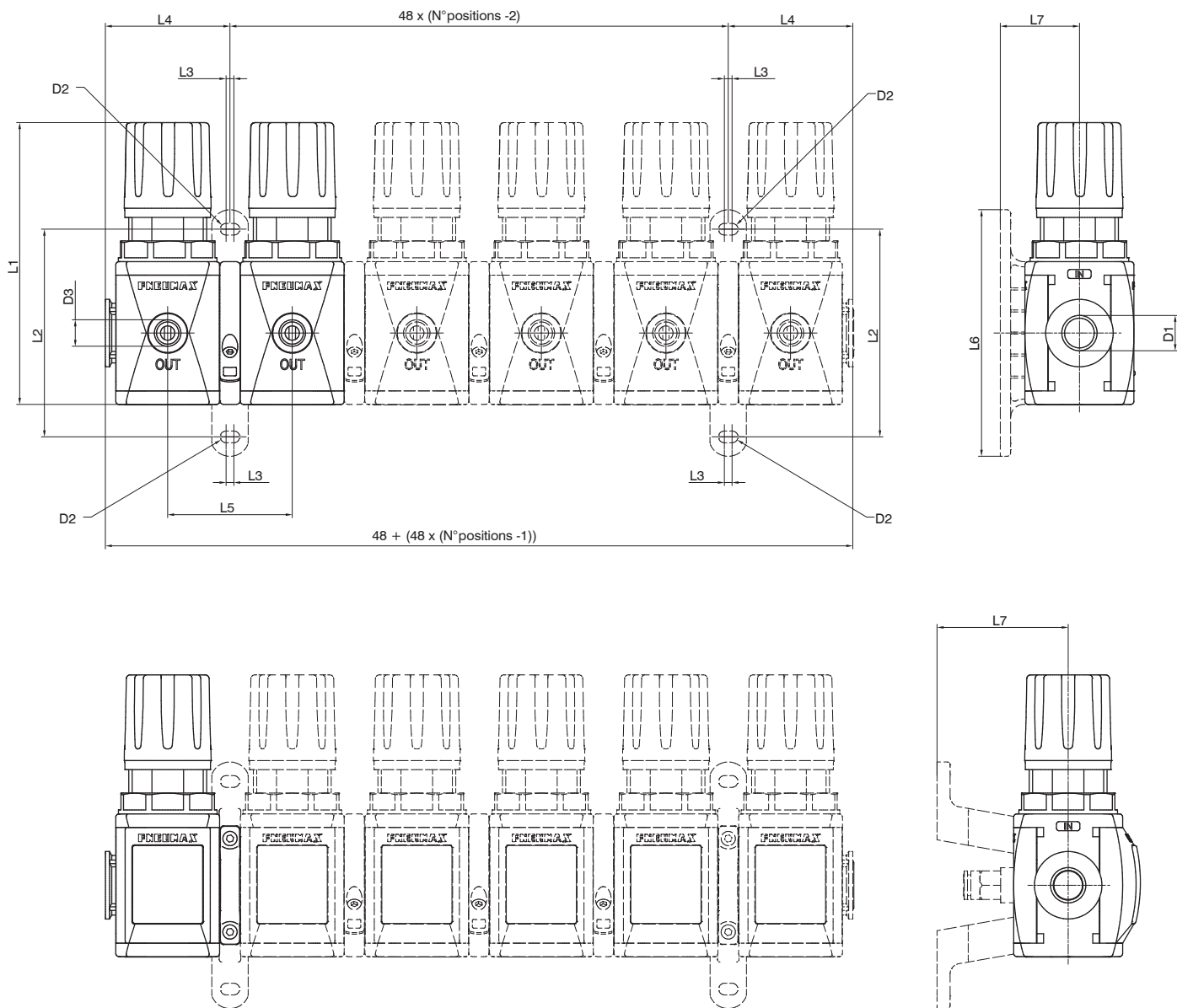

Model	D1	D2	D3	L1	L2	L3	L4	L5	L6	L7
#171..with flanges X	G1/4" G1/8" 1/4" NPT	/	G1/8"	109	/	/	48	48	/	/
#171..with flanges Y		Ø4,5			80	3			105	30,5
#171..with extended flanges Y										50,5



► Manifold mounting flanges

Flange Y

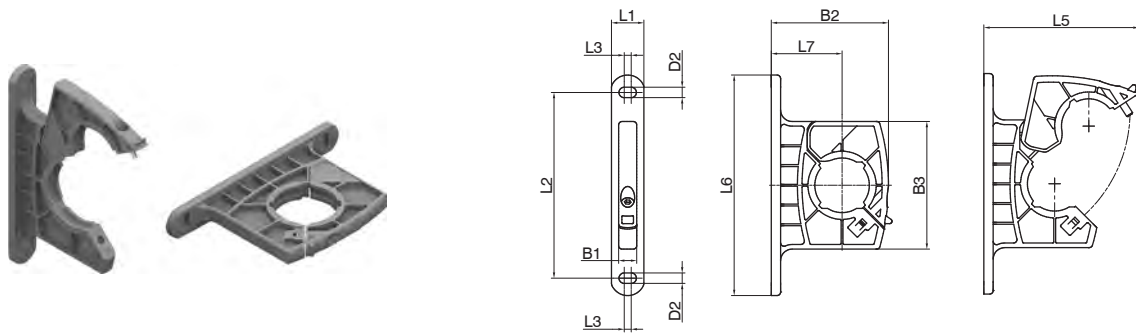

Extended flange Y

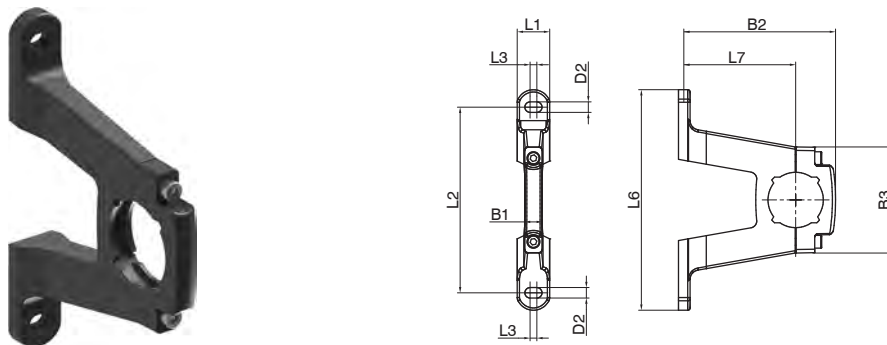

Flange X

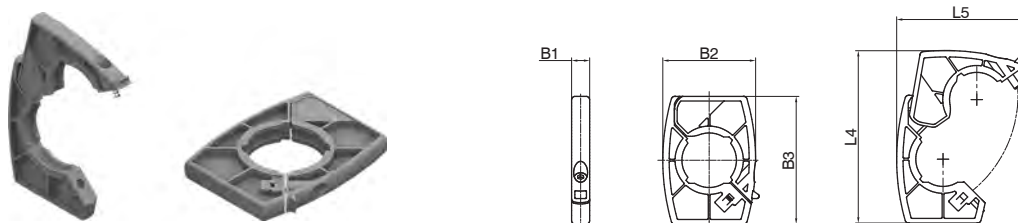

Model	B1	B2	B3	D2	L1	L2	L3	L4	L5	L6	L7
T171Y	7,8	50,5	55	Ø4,5	14	80	3	/	66	95	30,5
N171YP		67,7	45,7	Ø4,5	14	80	3	/	66		50,5
T171X		40	55	/	/	/	/	74,5	55,5	/	/

► Fixing bracket

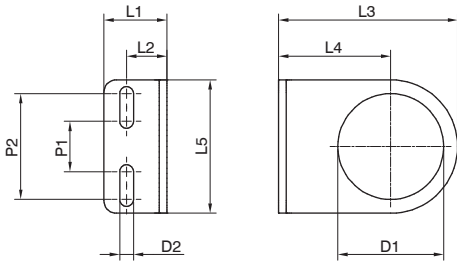

2  
AIR TREATMENT

Model	L1	L2	L3	L4	L5	D1	D2	P1	P2
17150	20	13	50	30	40	30	5,5	20	30

► Pressure gauge

17070 **A** **C**

Version
A : Dial Ø40
B : Dial Ø50

Scale
A : 0 - 4 bar
B : 0 - 6 bar
C : 0 - 12 bar

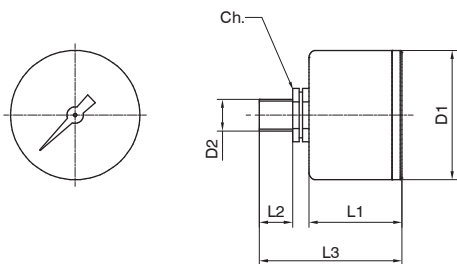

Model	L1	L2	L3	D1	D2	Ch
17070A..	26	10	44	41	Gc - 1/8"	14
17070B..	27	10	45	49	Gc - 1/8"	14



**Lubricators (L)**



- ▶ Oil mist lubricator
- ▶ Available in 4 sizes with flow rates up to 16000 NI/min and connections from 1/8" to 1"
- ▶ Bowl assembly via bayonet type quick coupling mechanism with safety button
- ▶ Variable orifice size in function of the flow rate
- ▶ Oil quantity regulation mechanism and oil quantity visualization dome made of polycarbonate (PC)
- ▶ Oil refill plug
- ▶ Lubricator oil recharge with pressurized system
- ▶ Available with low level electrical sensor NO and NC
- ▶ Atex certification (II 2GD or II 3GD)

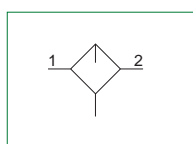

2

AIR TREATMENT

Technical characteristics		Size	Size 1	Size 2	Size 3	Size 4
<b>Body and connections type</b>		Technopolymer body, integrated technopolymer connections (T version) Technopolymer body, metal connections (N version) / Aluminium body, integrated aluminium connections (P version)				/
<b>Protection and bowl type</b>		Technopolymer protection - PC bowl Technopolymer protection - PA bowl Metal protection - PC bowl Metal protection - PA bowl				
<b>IN / OUT connections</b>	<b>T version</b>	G1/4"		G3/8"	G1/2"	non disponibile
	<b>N version</b>	G1/8" - G1/4" - 1/4" NPT		G3/8" - G1/4" - 3/8" NPT	G3/8" - G1/2" - 1/2" NPT	
	<b>P version</b>	not available		G3/8"	G1/2"	G1"
<b>Assembly configuration</b>		Stand alone /				Panel mounted
<b>Assembly positions</b>		Vertical ±5°				
<b>Bowl capacity</b>		36 cm³		70 cm³	136 cm³	360 cm³
<b>Lubrication type</b>		Oil mist lubrication				
<b>Oil level regulation</b>		Manual, complete with visual indicator				
<b>Max. fittings torque IN / OUT connections</b>		G1/8" metal: 15Nm G1/4" metal: 20Nm G1/4" technopolymer: 9Nm		G1/4" metal: 20Nm G3/8" metal: 25Nm G3/8" technopolymer: 16Nm	G3/8" metal: 25Nm G1/2" metal: 30Nm G1/2" technopolymer: 22Nm	G1" metal: 35Nm

Operational characteristics		Size	Size 1	Size 2	Size 3	Size 4
<b>Maximum working pressure</b>		13 bar				
<b>Minimum working pressure</b>		0,5 bar				
<b>Min. operational flow at 6,3 bar</b>		40 NI/min		70 NI/min	100 NI/min	100 NI/min
<b>Indicative oil drop rate</b>		1 drope every 300/600 NI/min				
<b>Oil type</b>		FD22 - HG32				
<b>Working temperature</b>		-5°C +50°C				

Weights				
Size	Size 1	Size 2	Size 3	Size 4
Fully technopolymer version	121 g	215 g	347 g	/
Technopolymer body version, aluminium bowl protection and technopolymer bowl	/	245 g	383 g	/
Aluminium body version, technopolymer protection and bowl	/	315 g	477 g	1032 g
Aluminium body version, aluminium bowl protection and technopolymer bowl	/	345 g	513 g	1077 g

**Materials**

Exploded sectioned

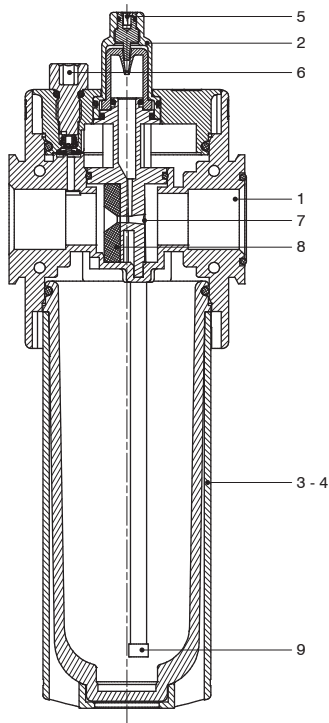

Lubricator		
1	Body	Polyamide Die-cast aluminium
2	Visual indicator	Polyamide
3	Technopolymer bowl	Polycarbonate Polyamide
4	Bowl protection	Polyamide - Die-cast aluminium
5	Oil regulation needle	Brass
6	Recharge plug	Acetal resin
7	Diaphragm support	Acetal resin
8	Diaphragm	NBR
9	Filter	Sintered brass

**Design**

**Size 1 - Size 2 - Size 3**  
Technopolymer protection

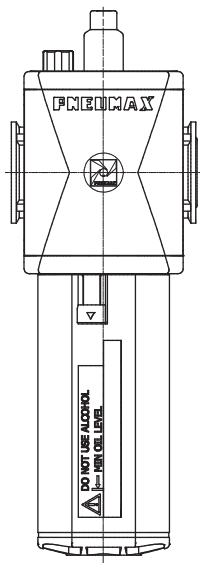

**Size 1 - Size 2 - Size 3**  
Metal protection

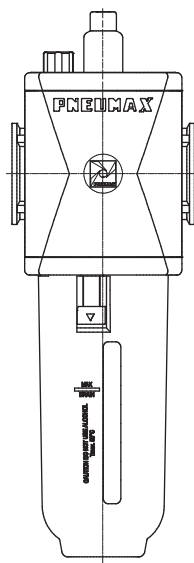

**Size 4**  
All versions

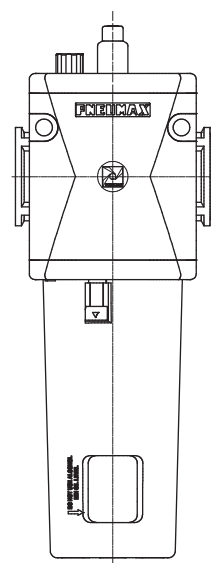



Order codes

	<b>T</b>	17	<b>3B</b>	L	<b>A</b>	<b>N</b>
<b>Version</b>						
<b>N</b> : Technopolymer body and metal inserts (not available for size 4)						
<b>T</b> : Technopolymer body and thread (not available for size 4)						
<b>P</b> : Aluminium body (not available for size 1)						
<b>Size and connections</b>						
<b>1A</b> : Size 1 - G1/8" only for N version						
<b>1B</b> : Size 1 - G1/4" only for T - N versions						
<b>1C</b> : Size 1 - 1/4" NPT only for N version						
<b>2A</b> : Size 2 - G1/4" only for N version						
<b>2B</b> : Size 2 - G3/8" for all versions						
<b>2C</b> : Size 2 - 3/8" NPT only for N version						
<b>3A</b> : Size 3 - G3/8" only for N version						
<b>3B</b> : Size 3 - G1/2" for all versions						
<b>3C</b> : Size 3 - 1/2" NPT only for N version						
<b>4B</b> : Size 4 - G1" only for P version						
<b>Options</b>						
: No electric level sensor device						
<b>A</b> : Electrical minimum level sensor NO (not available for size 1)						
<b>C</b> : Electrical minimum level sensor NC (not available for size 1)						
<b>Bowl options</b>						
: Technopolymer protection - PC bowl						
<b>N</b> : Technopolymer protection - PA bowl						
<b>P</b> : Metal protection - PC bowl (not available for size 1)						
<b>R</b> : Metal protection - PA bowl (not available for size 1)						

**Example : T173BLAN** : Size 3 lubricator G1/2", normally open low level electrical sensor, PA bowl with technopolymer protection

**Characteristic curves**

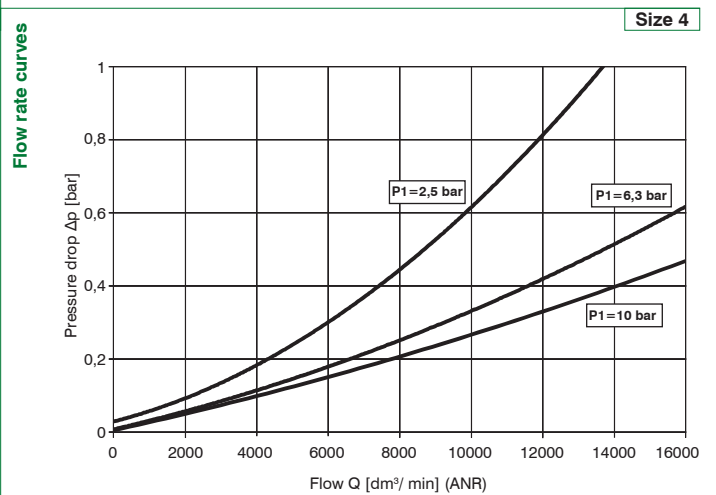
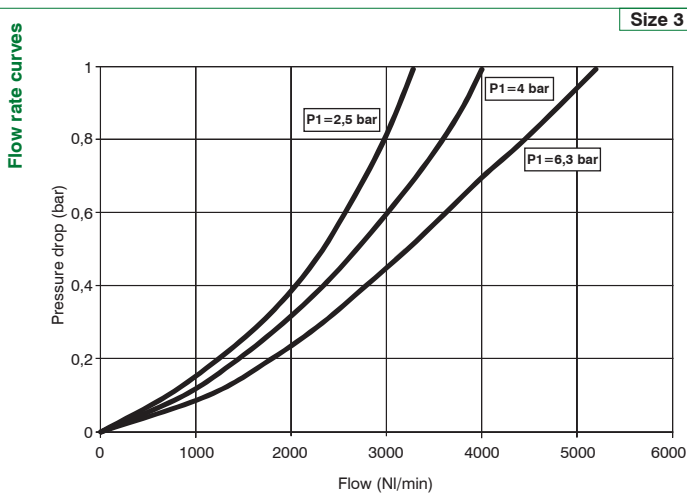
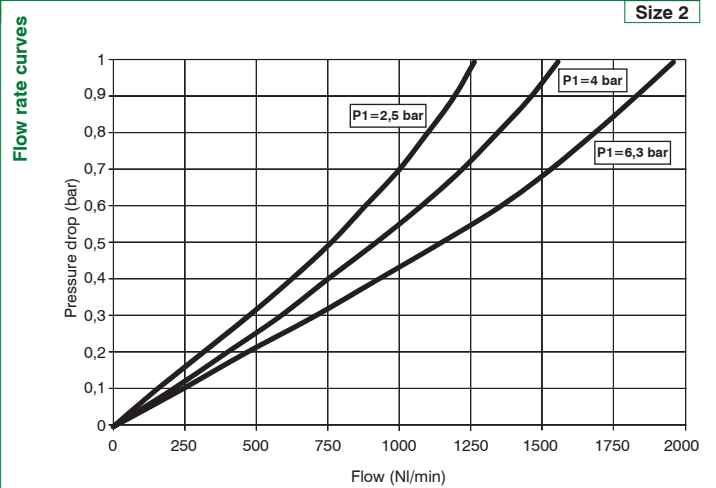
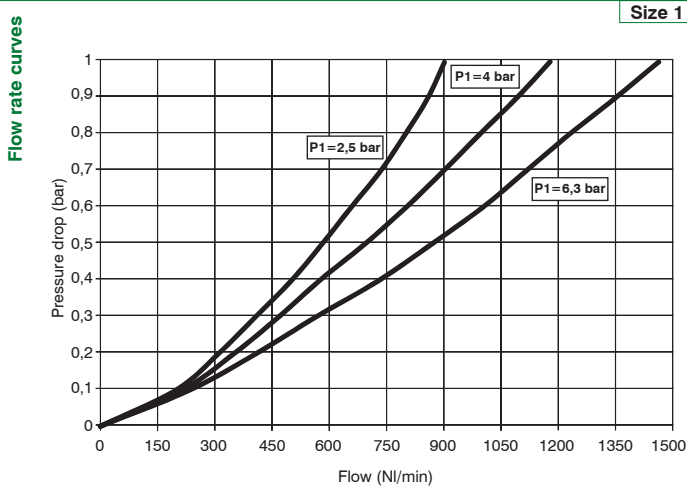

**Dimensions**

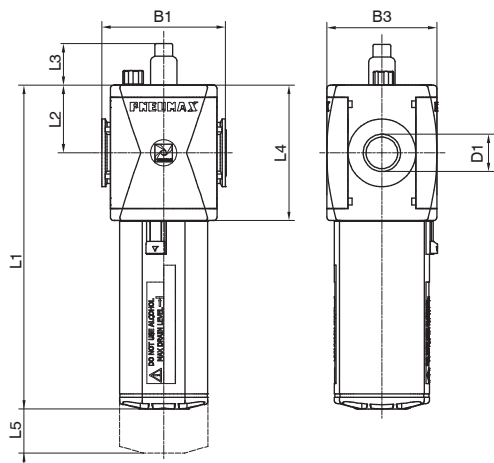

Fixing holes dimension detail (only for size 4)

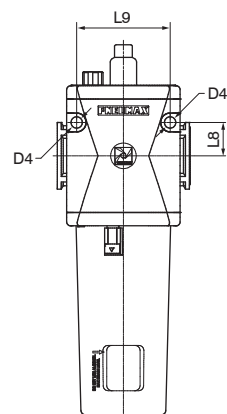

Model	B1	B3	D1	D4	L1	L2	L3	L4	L5	L8	L9
#171..	48	42	G1/8" G1/4" 1/4" NPT	/	131	27,5	24	55	80	/	/
#172..	62	57	G1/4" G3/8" 3/8" NPT	/	152.7	34	24	68	90	/	/
#173..	73	65	G3/8" G1/2" 1/2" NPT	/	191.4	40	24	80	120	/	/
#174..	99	88	G1"	8,5	247	52,5	24	105	145	25	70

## Variable dimensions

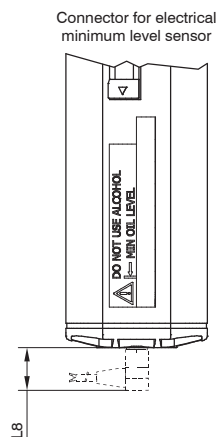

Model	L8	Connectors for electrical connection
Electrical minimum level sensor NO	16	C1 - C2 - C3 (see sensors section of general catalog)
Electrical minimum level sensor NC		

## Accessories

### Electrical connection details

**C1** : connector with 2,5 m cable 2 wires (PVC Ø3,5 mm 2x0,25mm<sup>2</sup>)

**C2** : connector with 5 m cable 2 wires (PVC Ø3,5 mm 2x0,25mm<sup>2</sup>)

**C3** : connector with 10 m cable 2 wires (PVC Ø3,5 mm 2x0,25mm<sup>2</sup>)

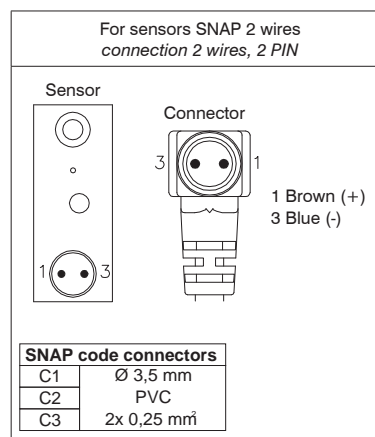

▶ Shut off valves (VL - VP - VE)



- ▶ 3/2 N.C. shut off valve
- ▶ Suitable for system downstream pneumatic feeding or exhaust
- ▶ Manual, pneumatic and electropneumatic operation available
- ▶ Up to 3off manual operation lockable device available (closed position)
- ▶ Atex certification (II 2GD or II 3GD)

2  
AIR TREATMENT

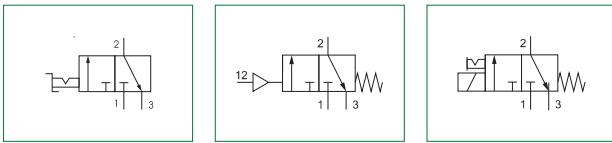

Technical characteristics					
Size		Size 1	Size 2	Size 3	Size 4
<b>Body and connections type</b>		Technopolymer body, integrated technopolymer connections (T version) Technopolymer body, metal connections (N version)			/
		/	Aluminium body, integrated aluminium connections (P version)		/
<b>Operated type</b>		Manual Pneumatic Electropneumatic			
<b>IN / OUT connections</b>	<b>T version</b>	G1/4"	G3/8"	G1/2"	not available
	<b>N version</b>	G1/8" - G1/4" - 1/4" NPT	G3/8" - G1/4" - 3/8" NPT	G3/8" - G1/2" - 1/2" NPT	
	<b>P and L version</b>	not available	G3/8"	G1/2"	
<b>Pilot connection</b>		G1/8"			
<b>Exhaust connection</b>		G1/4"	G3/8"	G1/2"	
<b>Assembly configuration</b>		Stand alone /			Panel mounted
<b>Assembly positions</b>		Indifferent			
<b>Max. fittings torque IN / OUT connections</b>		G1/8" metal: 15Nm G1/4" metal: 20Nm G1/4" technopolymer: 9Nm	G1/4" metal: 20Nm G3/8" metal: 25Nm G3/8" technopolymer: 16Nm	G3/8" metal: 25Nm G1/2" metal: 30Nm G1/2" technopolymer: 22Nm	G1/2" metal: 30Nm G1" metal: 35Nm

Operational characteristics								
Size	Size 1	Size 2	Size 3	Size 4	Size 1	Size 2	Size 3	Size 4
Operator	Manual				Pneumatic / Solenoid			
<b>Maximum working pressure</b>	13 bar			10 bar	10 bar			
<b>Minimum working pressure</b>	0,5 bar				2,5 bar			
<b>Working temperature</b>	-5°C +50°C				-5°C +50°C			
	-30°C +80°C (only for P version) -40°C +80°C (only for L version)				-30°C +80°C (only with metal body and pneumatic version) -40°C +80°C (only with metal body and pneumatic version)			
<b>Nominal flow rate at 6 bar with Δp=1 (from 1 to 2)</b>	1400 NI/min	2200 NI/min	3600 NI/min	15000 NI/min	1400 NI/min	2200 NI/min	3600 NI/min	15000 NI/min
<b>Exhaust nominal flow rate at 6 bar with Δp=1 (from 2 to 3)</b>	550 NI/min	1500 NI/min		3600 NI/min	550 NI/min	1500 NI/min		3600 NI/min
<b>Un-conveyed exhaust nominal flow rate (from 2 to 3)</b>	1000 NI/min	2500 NI/min		5000 NI/min	1000 NI/min	2500 NI/min		5000 NI/min



Weights								
Size Operator	Size 1				Size 2			
	Manual	Pneumatic	Solenoid M2 actuator	Solenoid 15mm coil	Manual	Pneumatic	Solenoid M2 actuator	Solenoid 15mm coil
Technopolymer body version	110 g	99 g	140 g	140 g	190 g	181 g	210 g	216 g
Aluminium body version	/	/	/	/	270 g	265 g	298 g	301 g

Size Operator	Size 3				Size 4			
	Manual	Pneumatic	Solenoid M2 actuator	Solenoid 15mm coil	Manual	Pneumatic	Solenoid M2 actuator	Solenoid 15mm coil
Technopolymer body version	250 g	270 g	310 g	310 g	/	/	/	/
Aluminium body version	400 g	398 g	429 g	432 g	1100 g	1135 g	1170 g	1180 g

**Materials**

Exploded sectioned

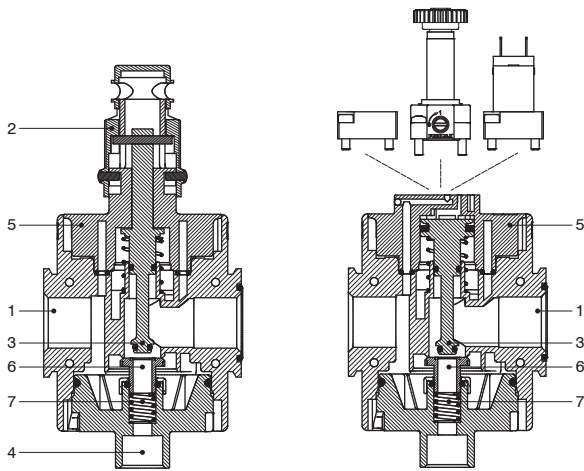

Shut off valve		
1	Body	Polyamide Die-cast aluminium
2	Manual override	Polyamide
3	Drive pin Piston	Aluminium
4	Exhaust plug	Polyamide
5	Central support	Polyamide
6	Spool	Brass + NBR
7	Repositioning spring	Steel

2  
AIR TREATMENT

**Design**

Manual operated version

Pneumatic operated version

Solenoid operated version

Size 1 - Size 2  
Size 3

Size 4

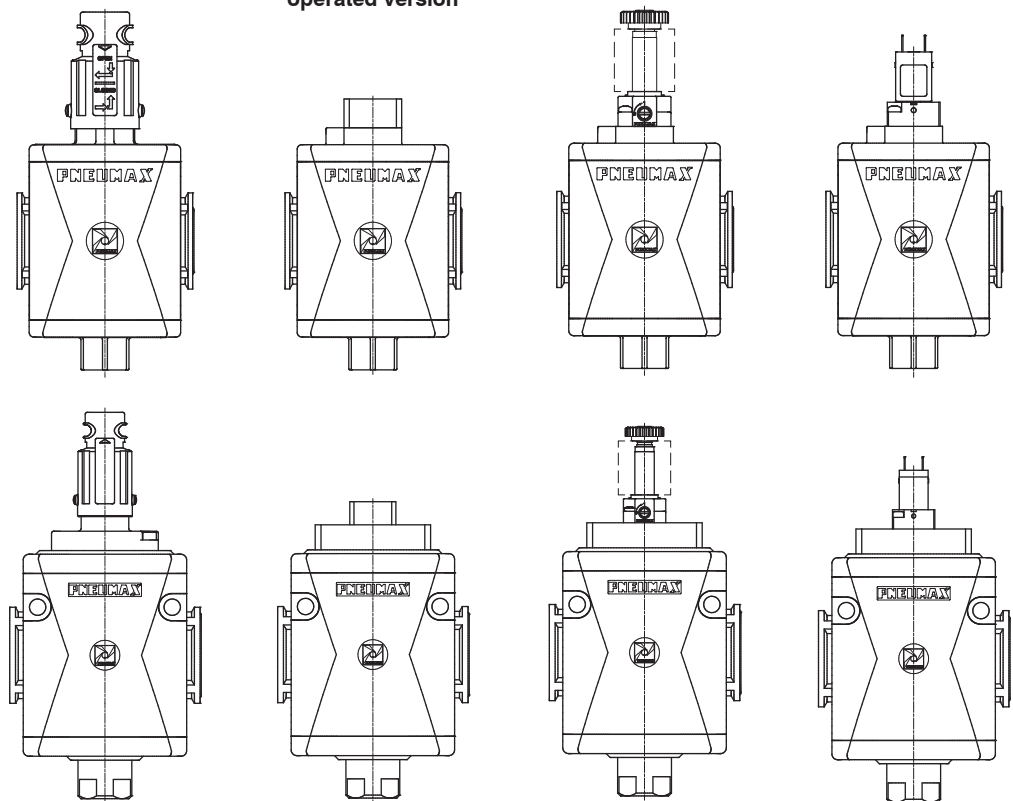



**Order codes**

T 17 3B V E A5

Version
N : Technopolymer body and metal inserts (not available for size 4)
T : Technopolymer body and thread (not available for size 4)
P : Aluminum body (not available for size 1)
L : Aluminium body, low temperature (not available for solenoid version)

Size and connections
1A : Size 1 - G1/8" only for N version
1B : Size 1 - G1/4" only for T - N versions
1C : Size 1 - 1/4" NPT only for N version
2A : Size 2 - G1/4" only for N version
2B : Size 2 - G3/8" for all versions
2C : Size 2 - 3/8" NPT only for N version
3A : Size 3 - G3/8" only for N version
3B : Size 3 - G1/2" for all versions
3C : Size 3 - 1/2" NPT only for N version
4B : Size 4 - G1" only for P - L versions

Operator
L : Manual
P : Pneumatic
E : Solenoid

Coil options
<b>15 mm coil</b>
A4 : 12 V DC
A5 : 24 V DC
A6 : 24 V AC (50-60 Hz)
A7 : 110 V AC (50-60 Hz)
A8 : 230 V AC (50-60 Hz)
A9 : 24 V DC (1 Watt)
<b>22 mm coil</b>
B2 : Mechanical M2, without coil
B4 : 12 V DC
B5 : 24 V DC
B6 : 24 V AC (50-60 Hz)
B7 : 110 V AC (50-60 Hz)
B8 : 230 V AC (50-60 Hz)
B9 : 24 V DC (2 Watt) (Atex certification not available)
<b>30 mm coil</b>
C5 : 24 V DC
C6 : 24 V AC (50-60 Hz)
C7 : 110 V AC (50-60 Hz)
C8 : 230 V AC (50-60 Hz)
C9 : 24 V DC (2 Watt) (Atex certification not available)

**Example : T173BVEA5** : Size 3 electric shut off valve G1/2", 15 mm coil, 24VDC

2 AIR TREATMENT

Dimensions

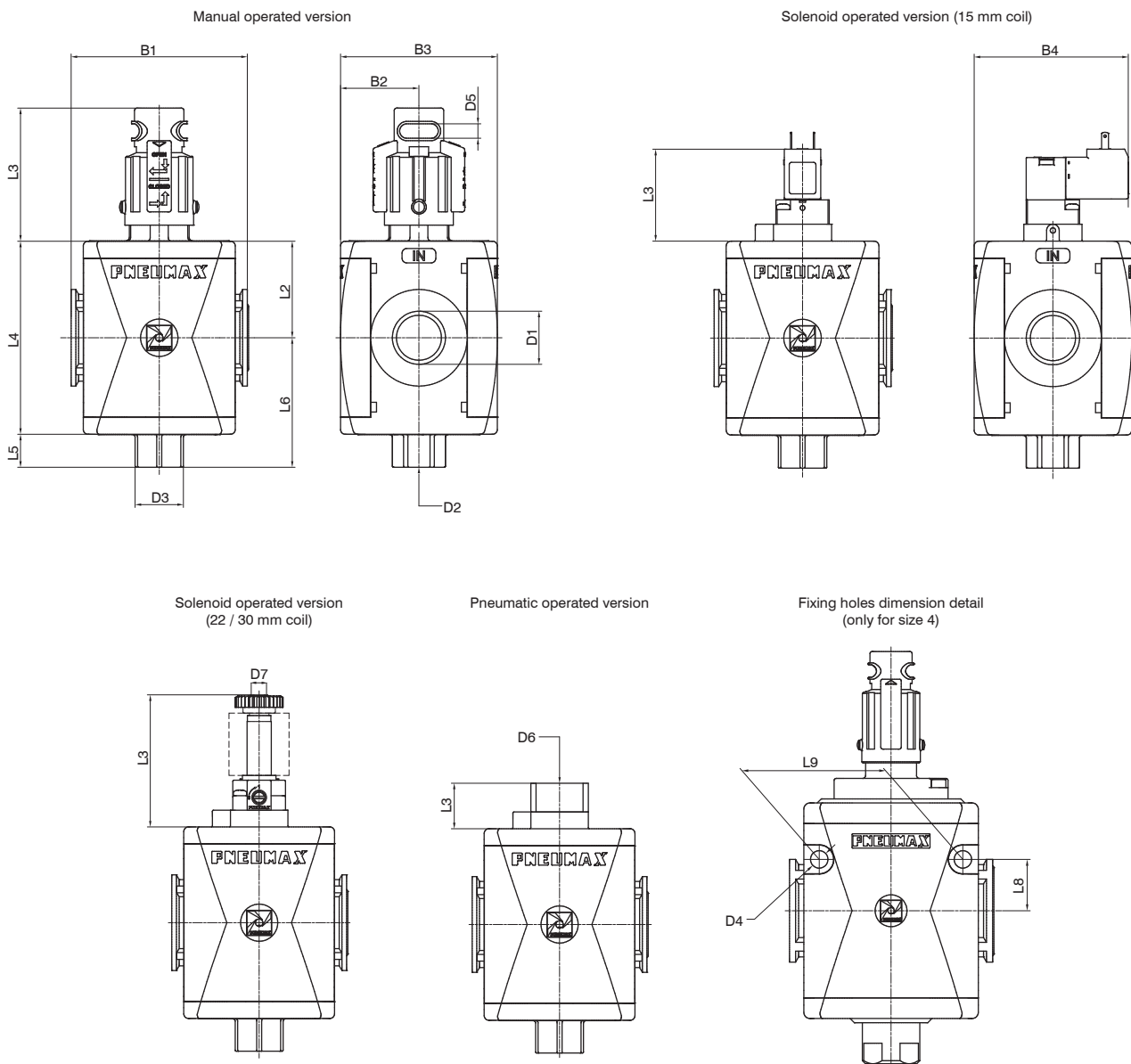

2  
AIR TREATMENT

Model	B1	B2	B3	B4	D1	D2	D3	D4	D5	D6	D7	L2	L3				L4	L5	L6	L8	L9
													Manual	Pneumatic	Solenoid coil 22 or 30mm	Solenoid 15mm coil					
#171..	48	21	42	52	G1/8" G1/4" 1/4" NPT	G1/4"	Ch.17	/	6	G1/8"	M5	27,5	55	19	57	37,5	55	11	38,5	/	/
#172..	62	28,5	57	59,6	G1/4" G3/8" 3/8" NPT	G3/8"	Ch.20	/	6	G1/8"	M5	34	54,2	22	60	40,3	68	14	48	/	/
#173..	73	32,5	65	63,6	G3/8" G1/2" 1/2" NPT	G3/8"	Ch.20	/	6	G1/8"	M5	40	55	19	57	37,4	80	14	54	/	/
#174..	99	44	88	75	G1"	G1/2"	Ch.25	8,5	6	G1/8"	M5	52,5	71,5	27	67	45,5	105	22	74,5	25	70

**Progressive start-up valve (AP - APW)**

- ▶ Progressive start-up valve
- ▶ Available in 4 sizes with flow rates up to 15000 NI/min and connections from 1/8" to 1"
- ▶ Suitable for downstream system gradual pressurization
- ▶ Downstream circuit filling time regulated via a built in flow regulator
- ▶ Full pressure is allowed once the down stream circuit pressure reaches 50% of the inlet pressure
- ▶ ATEX certification (II 2GD or II 3GD)

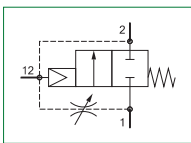
**2**
**AIR TREATMENT**

Technical characteristics					
Size		Size 1	Size 2	Size 3	Size 4
<b>Body and connections type</b>		Technopolymer body, integrated technopolymer connections (T version) Technopolymer body, metal connections (N version)			/
		/	Aluminium body, integrated aluminium connections (P version)		/
<b>IN / OUT connections</b>	<b>T version</b>	G1/4"	G3/8"	G1/2"	not available
	<b>N version</b>	G1/8" - G1/4" - 1/4" NPT	G3/8" - G1/4" - 3/8" NPT	G3/8" - G1/2" - 1/2" NPT	
	<b>P version</b>	not available	G3/8"	G1/2"	G1"
<b>Assembly configuration</b>		Stand alone /			Panel mounted
<b>Assembly positions</b>		Indifferent			
<b>Max. fittings torque IN / OUT connections</b>		G1/8" metal: 15Nm G1/4" metal: 20Nm G1/4" technopolymer: 9Nm	G1/4" metal: 20Nm G3/8" metal: 25Nm G3/8" technopolymer: 16Nm	G3/8" metal: 25Nm G1/2" metal: 30Nm G1/2" technopolymer: 22Nm	G1" metal: 35Nm

Operational characteristics				
Size	Size 1	Size 2	Size 3	Size 4
<b>Maximum working pressure</b>	13 bar			10 bar
<b>Minimum working pressure</b>	2,5 bar			
<b>Working temperature</b>	-5°C +50°C			
<b>Nominal flow rate at 6 bar with Δp=1 (from 1 to 2)</b>	1400 NI/min	2200 NI/min	3600 NI/min	15000 NI/min
<b>Fully open flow control device maximum flow rate</b>	75 NI/min	200 NI/min	200 NI/min	1000 NI/min

Weights					
	Size	Size 1	Size 2	Size 3	Size 4
Technopolymer body version		80 g	150 g	240 g	/
Aluminium body version		/	235 g	370 g	1100 g

### Materials

Exploded sectioned

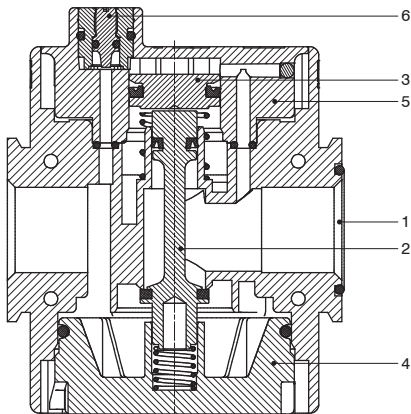

#### Progressive start-up valve

1	Body	Polyamide Die-cast aluminium
2	Drive pin	Aluminium
3	Piston	Aluminium
4	Rear end cap	Polyamide / Die-cast aluminium
5	Central support	Polyamide / Aluminium
6	Modulating needle	Brass

2

AIR TREATMENT

### Design

Size 1 - Size 2 - Size 3

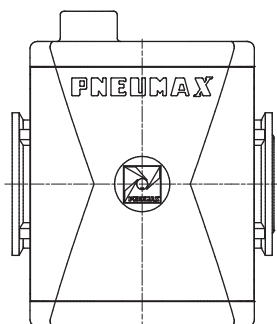

Size 4

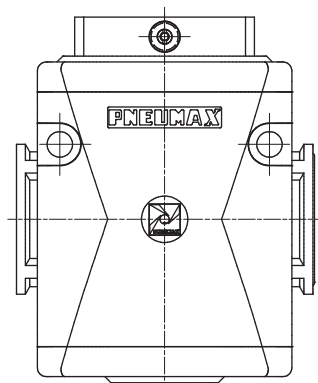



**Order codes**

T 17 3B AP

Version
<b>N</b> : Technopolymer body and metal inserts (not available for size 4)
<b>T</b> : Technopolymer body and thread (not available for size 4)
<b>P</b> : Aluminum body (not available for size 1)

Size and connections
<b>1A</b> : Size 1 - G1/8" only for N version
<b>1B</b> : Size 1 - G1/4" only for T - N versions
<b>1C</b> : Size 1 - 1/4" NPT only for N version
<b>2A</b> : Size 2 - G1/4" only for N version
<b>2B</b> : Size 2 - G3/8" for all versions
<b>2C</b> : Size 2 - 3/8" NPT only for N version
<b>3A</b> : Size 3 - G3/8" only for N version
<b>3B</b> : Size 3 - G1/2" for all versions
<b>3C</b> : Size 3 - 1/2" NPT only for N version
<b>4B</b> : Size 4 - G1" only for P version

Flow direction (only for size 4)
<b>:</b> : From left to right
<b>W</b> : From right to left

**Example : T173BAP** : Size 3 progressive start-up valve G1/2"

2 AIR TREATMENT

**Dimensions**

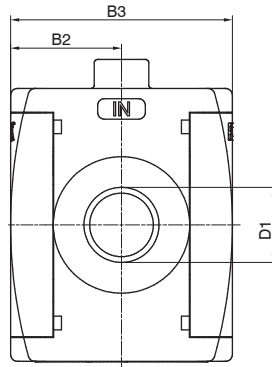
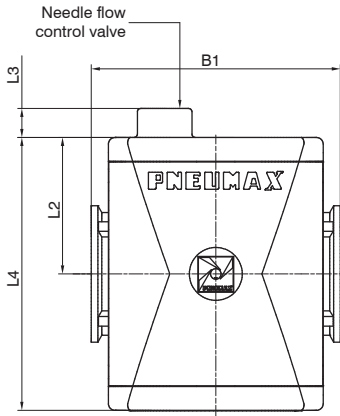

Fixing holes dimension detail (only for size 4)

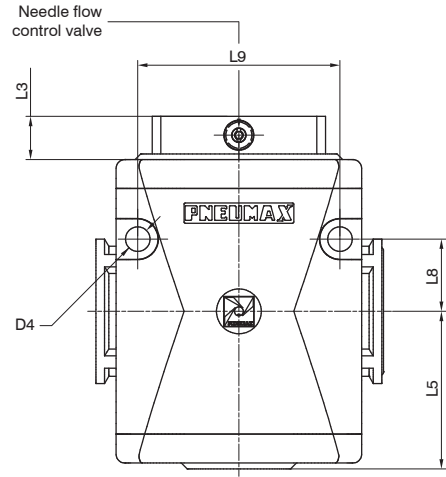

Model	B1	B2	B3	D1	D4	L2	L3	L4	L5	L8	L9
#171..	48	21	42	G1/8" G1/4"	/	27,5	12	55	/	/	/
#172..	62	28,5	57	G1/4" G3/8"	/	34	9,2	68	/	/	/
#173..	73	32,5	65	G3/8" G1/2"	/	40	8,7	80	/	/	/
#174..	99	44	88	G1"	8,5	52,5	13	105	54,5	25	70

**Air intake (PA)**



- ▶ Pneumatic by-pass
- ▶ Available with 2 threaded connections
- ▶ Atex certification (II 2GD or II 3GD)

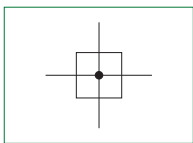

2  
AIR TREATMENT

Technical characteristics		Size	Size 1	Size 2	Size 3	Size 4
<b>Body and connections type</b>			Technopolymer body, integrated technopolymer connections (T version) Technopolymer body, metal connections (N version)			/
			Aluminium body, integrated aluminium connections (P version)			/
<b>IN / OUT / INTAKE connections</b>	<b>T version</b>		G1/4"	G3/8"	G1/2"	not available
	<b>N version</b>		G1/8" - G1/4" - 1/4" NPT	G3/8" - G1/4" - 3/8" NPT	G3/8" - G1/2" - 1/2" NPT	
	<b>P version</b>		not available	G3/8"	G1/2"	G1"
<b>Assembly configuration</b>			Stand alone /			Panel mounted
<b>Assembly positions</b>			Indifferent			
<b>Max. fittings torque IN / OUT / INTAKE connections</b>			G1/8" metal: 15Nm G1/4" metal: 20Nm G1/4" technopolymer: 9Nm	G1/4" metal: 20Nm G3/8" metal: 25Nm G3/8" technopolymer: 16Nm	G3/8" metal: 25Nm G1/2" metal: 30Nm G1/2" technopolymer: 22Nm	G1" metal: 35Nm

Operational characteristics		Size	Size 1	Size 2	Size 3	Size 4
<b>Maximum working pressure</b>				13 bar		20 bar
<b>Working temperature</b>				-5°C +50°C		-30°C +80°C (only for P version)

Weights		Size	Size 1	Size 2	Size 3	Size 4
Technopolymer body version			52 g	95,5 g	151 g	/
Aluminium body version			/	248 g	370 g	720 g

**Design**

Size 1 - Size 2 - Size 3

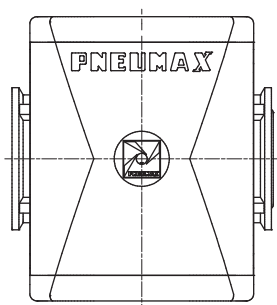

Size 4

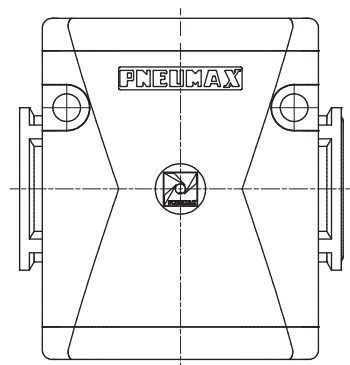



**Order codes**

T 17 3B PA

Version
N : Technopolymer body and metal inserts (not available for size 4)
T : Technopolymer body and thread (not available for size 4)
P : Aluminium body (not available for size 1)

Size and connections
1A : Size 1 - G1/8" only for N version
1B : Size 1 - G1/4" only for T - N versions
1C : Size 1 - 1/4" NPT only for N version
2A : Size 2 - G1/4" only for N version
2B : Size 2 - G3/8" for all versions
2C : Size 2 - 3/8" NPT only for N version
3A : Size 3 - G3/8" only for N version
3B : Size 3 - G1/2" for all versions
3C : Size 3 - 1/2" NPT only for N version
4B : Size 4 - G1" only for P version

**Example : T173BPA : Size 3 air intake G1/2"**

**Dimensions**

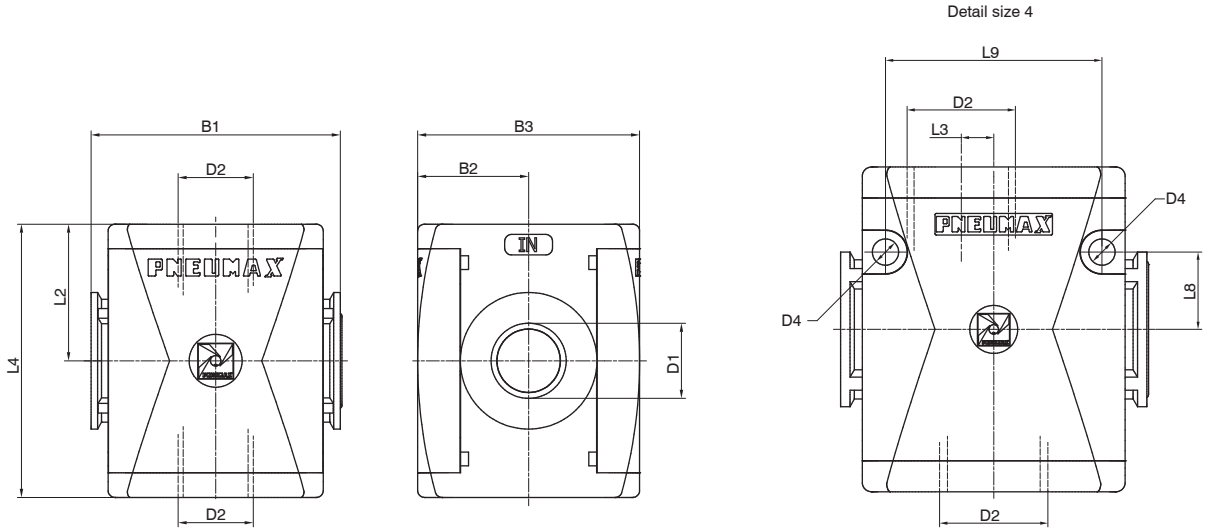

Model	B1	B2	B3	D1	D2	D4	L2	L3	L4	L8	L9
#171..	48	21	42	G1/8" G1/4" 1/4" NPT	/	/	27,5	/	55	/	/
#172..	62	28,5	57	G3/8" G1/4" 3/8" NPT	/	/	34	/	68	/	/
#173..	73	32,5	65	G3/8" G1/2" 1/2" NPT	/	/	40	/	80	/	/
#174..	99	44	88	G1"	8,5	8,5	52,5	10,5	105	25	70

2 AIR TREATMENT



► Pressure switch (PP)



- 2 to 10 bar adjustable pressure switch with electrical connection
- The electrical connection is made by mean of a 15 mm connector (DIN 43650 type C)
- The microswitch contact could be normally closed or open (change overswitch)

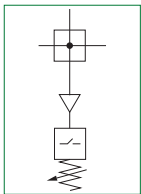

Technical characteristics		Size	Size 1	Size 2	Size 3	Size 4
<b>Body and connections type</b>			Technopolymer body, integrated technopolymer connections (T version) Technopolymer body, metal connections (N version)	Aluminium body, integrated aluminium connections (P version)		/
<b>IN / OUT / INTAKE connections</b>	<b>T version</b>		G1/4"	G3/8"	G1/2"	not available
	<b>N version</b>		G1/8" - G1/4" - 1/4" NPT	G3/8" - G1/4" - 3/8" NPT	G3/8" - G1/2" - 1/2" NPT	
	<b>P version</b>		not available	G3/8"	G1/2"	G1"
<b>Assembly configuration</b>			Stand alone /			Panel mounted
<b>Assembly positions</b>			Indifferent			
<b>Microswitch capacity</b>			1A			
<b>Microswitch maximum tension</b>			250 VAC			
<b>Microswitch IP Rating</b>			IP65 (with connector installed)			
<b>Max. fitting torque IN / OUT / INTAKE connections</b>			G1/8" metal: 15Nm G1/4" metal: 20Nm G1/4" technopolymer: 9Nm	G1/4" metal: 20Nm G3/8" metal: 25Nm G3/8" technopolymer: 16Nm	G3/8" metal: 25Nm G1/2" metal: 30Nm G1/2" technopolymer: 22Nm	G1" metal: 35Nm

Operational characteristics		Size	Size 1	Size 2	Size 3	Size 4
<b>Maximum working pressure</b>			13 bar			
<b>Working temperature</b>			-5°C +50°C			
<b>Operating pressure range</b>			2 - 10 bar			



Weights					
	Size	Size 1	Size 2	Size 3	Size 4
Technopolymer body version		138 g	179 g	235 g	/
Aluminium body version		/	330 g	780 g	800 g

**Design**

Size 1 - Size 2 - Size 3

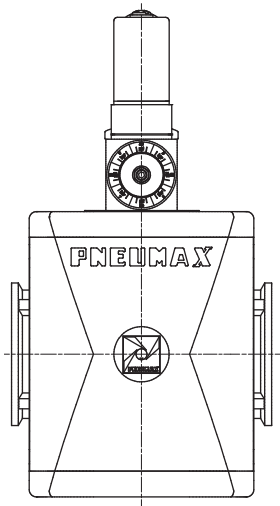

Size 4

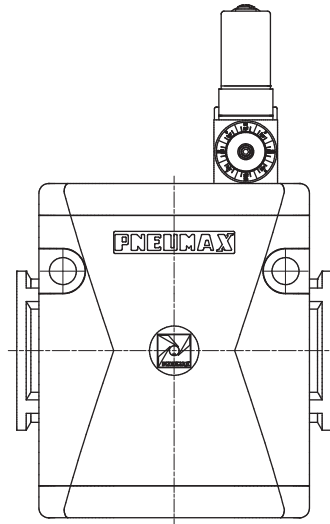

2  
AIR TREATMENT

**Order codes**

T 17 3B PP

Version
<b>N</b> : Technopolymer body and metal inserts (not available for size 4)
<b>T</b> : Technopolymer body and thread (not available for size 4)
<b>P</b> : Aluminum body (not available for size 1)

Size and connections
<b>1A</b> : Size 1 - G1/8" only for N version
<b>1B</b> : Size 1 - G1/4" only for T - N versions
<b>1C</b> : Size 1 - 1/4" NPT only for N version
<b>2A</b> : Size 2 - G1/4" only for N version
<b>2B</b> : Size 2 - G3/8" for all versions
<b>2C</b> : Size 2 - 3/8" NPT only for N version
<b>3A</b> : Size 3 - G3/8" only for N version
<b>3B</b> : Size 3 - G1/2" for all versions
<b>3C</b> : Size 3 - 1/2" NPT only for N version
<b>4B</b> : Size 4 - G1" only for P version

Flow direction (only for P version)
<b>:</b> : From left to right
<b>W</b> : From right to left

**Example : T173BPP** : Size 3 pressure switch G1/2"

Dimensions

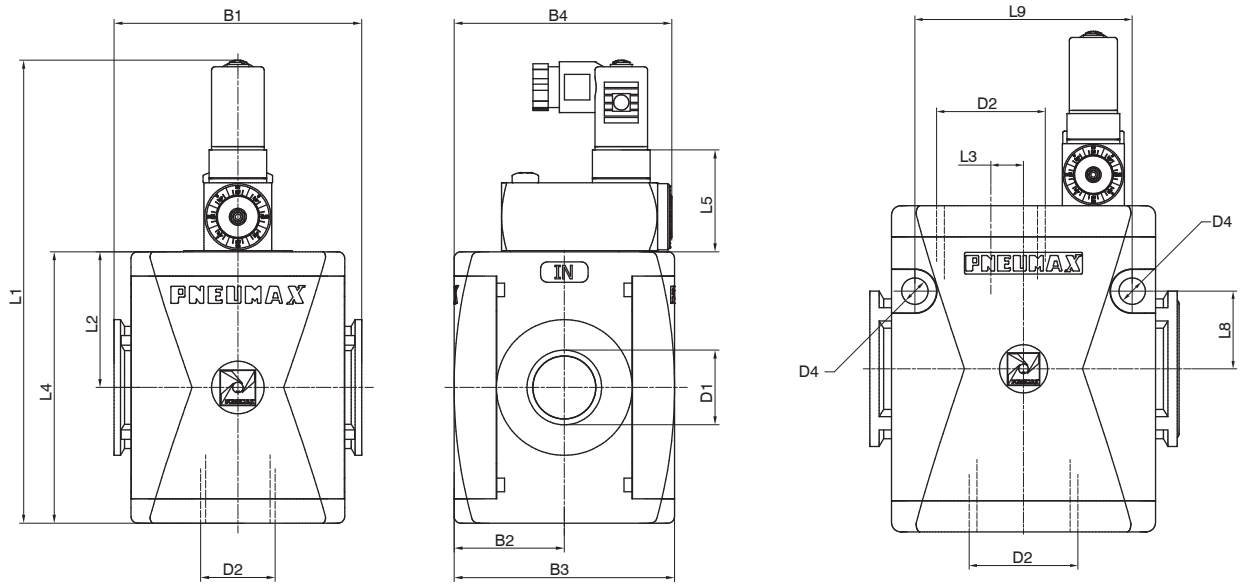

Model	B1	B2	B3	D1	D2	D4	L1	L2	L3	L4	L5	L8	L9
#171..	48	21	42	G1/8" G1/4" 1/4" NPT	/	/	114,7	27,5	/	55	32,7	/	/
#172..	62	28,5	57	G3/8" G1/4" 3/8" NPT	/	/	125	34	/	68	30	/	/
#173..	73	32,5	65	G3/8" G1/2" 1/2" NPT	/	/	137	40	/	80	30	/	/
#174..	99	44	88	G1"	8,5	162	52,5	10,5	105	30	25	70	

Electrical connection

- 1 = neutral
- 2 = N.C. contact
- 3 = N.O. contact

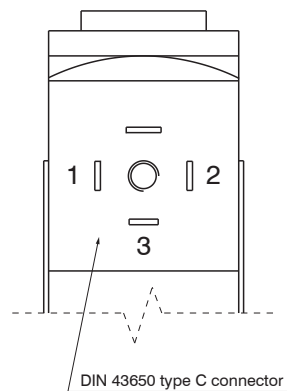

**Air intake with pressure gauge or digital pressure switch integrated (PM-PW-PP-PZ)**

- ▶ Available with pressure gauge or digital pressure switch integrated
- ▶ Air intake connection device available
- ▶ Material and version wide selection
- ▶ Available in 4 sizes with connections from 1/8" to 1"
- ▶ Atex certification (II 2GD or II 3GD)  
for Integrated pressure gauge version

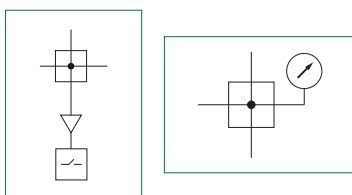
**2**
**AIR TREATMENT**

Technical characteristics					
Size		Size 1	Size 2	Size 3	Size 4
<b>Body and connections type</b>		Technopolymer body, integrated technopolymer connections Technopolymer body, metal connections / Aluminium body, integrated aluminium connections			/ /
<b>IN / OUT connections</b>	<b>T version</b>	G1/4"	G3/8"	G1/2"	not available
	<b>N version</b>	G1/8" - G1/4" - 1/4" NPT	G3/8" - G1/4" - 3/8" NPT	G3/8" - G1/2" - 1/2" NPT	
	<b>P version</b>	not available	G3/8"	G1/2"	G1"
<b>Air intake connection</b>		G1/4"	G3/8"	G3/8"	G1/2"
<b>Assembly configuration</b>		Stand alone /			Panel mounted
<b>Assembly positions</b>		Indifferent			
<b>Pressure measurement</b>		Integrated pressure gauge Digital pressure switch			
<b>Max. fittings torque IN / OUT connections</b>		G1/8" metal: 15Nm G1/4" metal: 20Nm G1/4" technopolymer: 9Nm	G1/4" metal: 20Nm G3/8" metal: 25Nm G3/8" technopolymer: 16Nm	G3/8" metal: 25Nm G1/2" metal: 30Nm G1/2" technopolymer: 22Nm	G1"metal: 35Nm

Operational characteristics				
Size	Size 1	Size 2	Size 3	Size 4
<b>Maximum working pressure</b>	13 bar			
<b>Working temperature with integrated pressure gauge</b>	-5°C +50°C		-30°C +80°C (only with metal body)	
<b>Working temperature with digital pressure switch</b>	0°C +50°C			

Weights					
	Size	Size 1	Size 2	Size 3	Size 4
Technopolymer body version with Integrated pressure gauge		83 g	161 g	249 g	/
Technopolymer body version with integrated digital pressure switch		111 g	189 g	277 g	/
Aluminium body version with Integrated pressure gauge		/	245 g	373 g	947 g
Aluminium body version with integrated digital pressure switch		/	273 g	401 g	963 g

**Design**

**Size 1 - Size 2 - Size 3**  
Technopolymer body and  
integrated pressure  
gauge

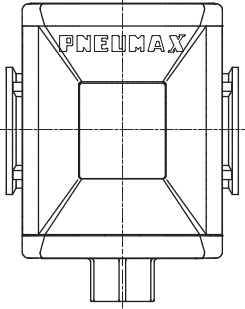

**Size 1 - Size 2 - Size 3**  
Technopolymer body and  
integrated digital  
pressure switch

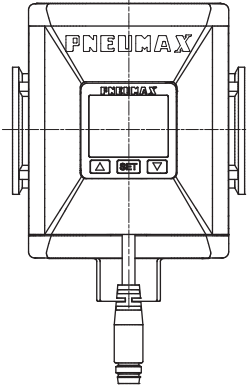

**Size 2 - Size 3**  
Aluminium body and  
integrated pressure  
gauge

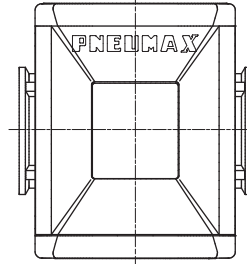

**Size 2 - Size 3**  
Aluminium body and  
integrated digital  
pressure switch

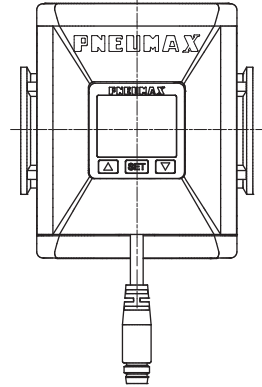

**Size 4**  
Integrated pressure  
gauge version

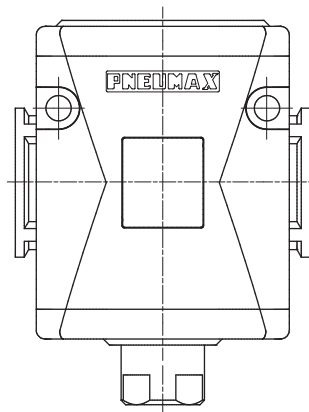

**Size 4**  
Integrated digital  
pressure switch version

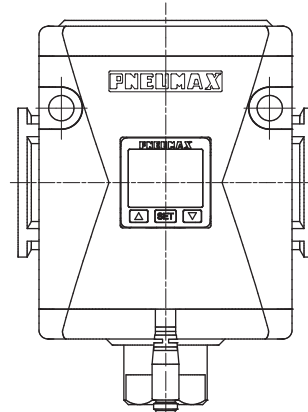



**Order codes**

T 17 3B P P A

Version
N : Technopolymer body and metal inserts (not available for size 4)
T : Technopolymer body and thread (not available for size 4)
P : Aluminum body (not available for size 1)

Size and connections
1A : Size 1 - G1/8" only for N version
1B : Size 1 - G1/4" only for T - N versions
1C : Size 1 - 1/4" NPT only for N version
2A : Size 2 - G1/4" only for N version
2B : Size 2 - G3/8" for all versions
2C : Size 2 - 3/8" NPT only for N version
3A : Size 3 - G3/8" only for N version
3B : Size 3 - G1/2" for all versions
3C : Size 3 - 1/2" NPT only for N version
4B : Size 4 - G1" only for P version

Pressure measurement options
M : Integrated pressure gauge
W : Integrated pressure gauge Right - Left
P : Digital pressure switch
Z : Digital pressure switch Right - Left

Digital pressure switch options
A : Cable 150 mm + M8 PNP
B : Cable 150 mm + M8 NPN
C : Cable 2 m PNP
D : Cable 2 m NPN

**Example : T173BPPA : M8 PNP digital pressure switch, size 3 G1/2"**

2 AIR TREATMENT

**Dimensions - Integrated pressure gauge version**

Technopolymer body version

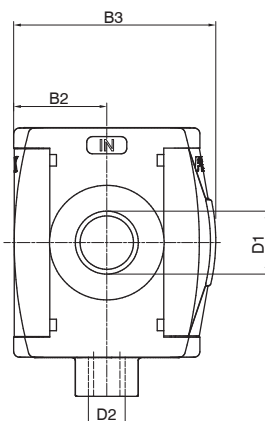
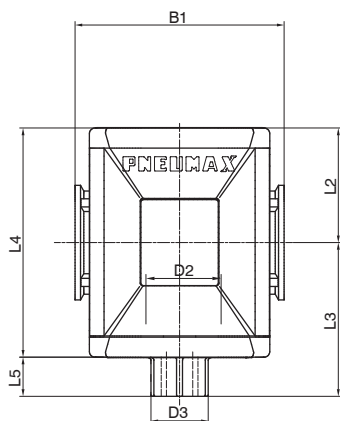

Fixing holes dimension detail (only for size 4)

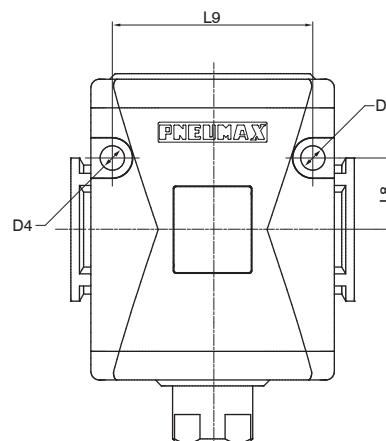

Aluminium body version (Size 2 - Size 3)

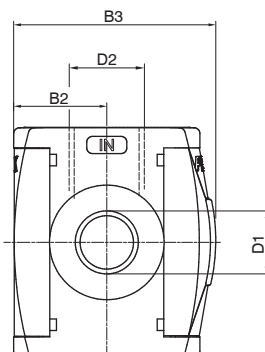
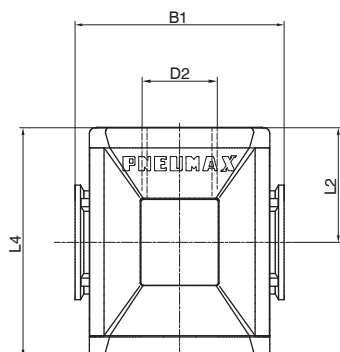

Model	B1	B2	B3	D1	D2	D3	D4	L2	L3	L4	L5	L8	L9
#171..	48	21	48,5	G1/8" G1/4" 1/4" NPT	G1/4"	Ch. 17	/	27,5	38,5	55	11	/	/
#172..	62	28,5	62,5	G1/4" G3/8" 3/8" NPT	G3/8"	Ch. 20	/	34	48	68	14	/	/
#173..	73	32,5	70,5	G3/8" G1/2" 1/2" NPT	G3/8"	Ch. 20	/	40	54	80	14	/	/
#174..	99	44	90,5	G1"	G1/2"	Ch. 25	8,5	52,5	74,5	105	22	25	70

Variable dimensions - Digital pressure switch version

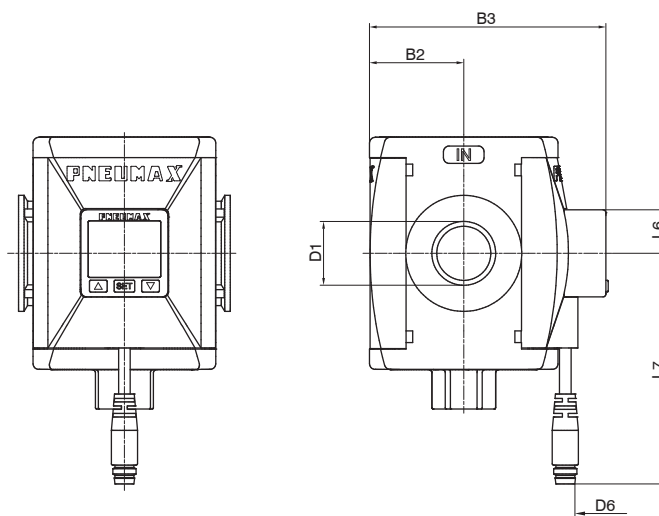

2

AIR TREATMENT

Model	B2	B3	D1	D6 - Type of digital pressure switch		L6	L7 - Type of digital pressure switch	
				A - B	C - D		A - B	C - D
#171..	21	60	G1/8" G1/4" 1/4" NPT	M8 - 3 PIN	3 x 0,129 mm, Ø4 mm	15	150	2000
#172..	28,5	73,5	G1/4" G3/8" 3/8" NPT					
#173..	32,5	81,5	G3/8" G1/2" 1/2" NPT					
#174..	44	101,5	G1"					

► **Digital pressure switch**



- 3 color digital LCD display, easy readout
- 4 units of measurement for pressure indication
- Optional PNP or NPN digital output
- N.O. and N.C. output contact selection directly on the digital pressure switch
- Available with M8-3PIN connector or 3 wire cable length 2 m
- Available only in combination with a air intake

2

AIR TREATMENT

**Output circuit wiring diagrams**

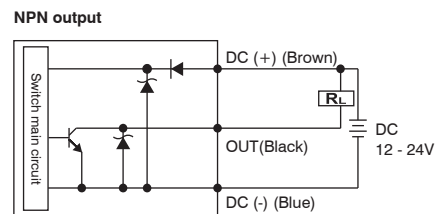
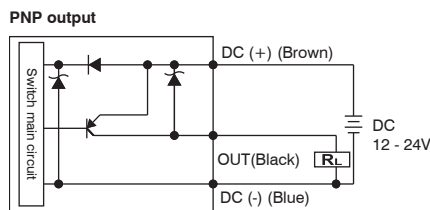

**Digital pressure switch lay out**

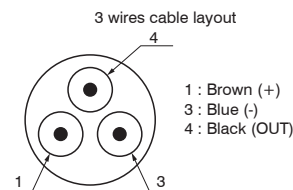
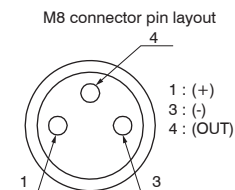

**Cable ordering code**

- MCH1** : cable 3 wires l=2,5m with M8 connector
- MCH2** : cable 3 wires l=5m with M8 connector
- MCH3** : cable 3 wires l=10m with M8 connector



Technical characteristics	
Pressure range and display	0 - 10 bar
Max. inlet pressure	15 bar
Fluid	40µm filtered and dehumidified air
Display unit of measurement	MPa - kgf/cm <sup>2</sup> - bar - psi
Supply voltage	12 - 24 VDC
Current consumption	≤40mA (without load)
Digital output type	PNP - NPN
Type of contact output	Normally Open - Normally Closed
Max. load current	125 mA
Digital output activation mode	single threshold with fixed hysteresis - window with fixed hysteresis - window without hysteresis
Digital output activation time	0.05s - 0.25s - 0.5s - 1s - 2s - 3s (selections for chattering-proof options)
Display characteristics	Double 3 1/2 digit display Digital output status indication Three-pushbuttons touchpad
Indicator accuracy	≤ ±2% full scale value ± 1 digit
IP Rating	IP40
Working temperature	0°C + 50°C
Cable section	3 x 0,129mm <sup>2</sup> , Ø4 mm, PVC



## Supply and discharge valves SAFELINE

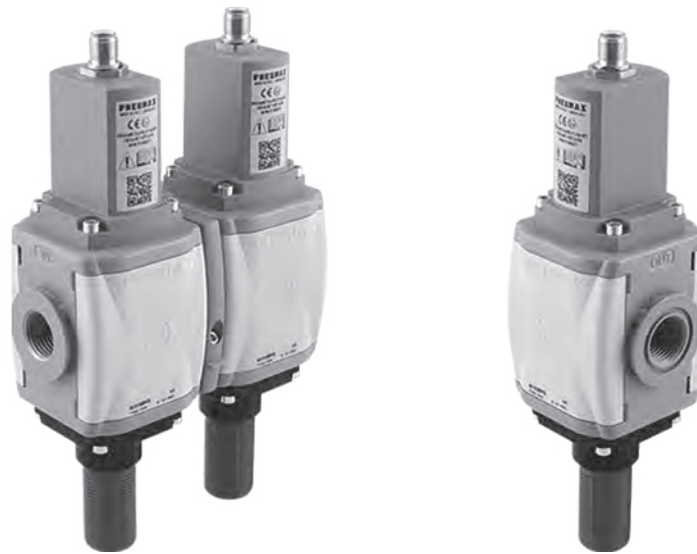

### General

Upon implementation of the AIRPLUS TG3 series, air-treatment units, PNEUMAX develops a supply and discharge valve, with an electropneumatic control and spring-return, fitted with a diagnostic system regarding the state of the valve, with the possibility of creating a double channel to determine the system's redundancy. The valve, as a safety feature, provides the interruption of the air supply and the exhaust of the air circuit it is connected to. The version with one single channel emphasises the features of an EV 3/2 NC, monostable with electropneumatic control and spring-return, whose operation involves:

- condition of the VALVE AT REST, with a DE-ENERGISED coil; Port 1 (air supply) is not been connected to Port 2 (downstream air circuit). Port 2 is discharged out of Port 3;
- condition of the VALVE ACTIVATED, with an ENERGISED coil; Port 1 (air supply) is connected to Port 2 (downstream air circuit), with Port 3 (Discharge) closed.

By de-energising the coil, the system resets the condition of VALVE AT REST by means of the return spring, which repositions the spool. Once again Port 2 (downstream air circuit), discharges via Port 3. The state of the valve is constantly monitored by a diagnostic system, using a Hall effect sensor, which reads the position of the spool and consequently takes note of the valve's position.

The sensor is in the ON position when the valve is at rest (DE-ENERGISED coil), while it is in the OFF position when the valve is activated (ENERGISED coil).

The sensor is in the OFF position under conditions of an activated valve (DE-ENERGISED coil), indicating a possible problem.

**The SAFELINE supply and discharge valve in the single version is a classified component in CATEGORY 2 according to ISO EN 13849 and is appropriate for use in safety circuits until PL=C.**

The version with a double redundant channel is made using two single solenoid valves 3/2 NC provided with diagnostics, mounted in series so that the Port 2 of the first solenoid valve is linked to the Port 1 of the second solenoid valve. It is sufficient that only one of the EV is de-energised to guarantee the discharge of the air circuit. If one of the two EV must remain blocked due to a malfunction, the other one ensures the discharge function of the pneumatic installation. Even in this case, the diagnostic system of both solenoid valves constantly monitors the state of the 2 single EV.

**The SAFELINE supply and discharge valve in the double version is a classified component in CATEGORY 4 according to ISO EN 13849 and is appropriate for use in safety circuits until PL=E.**

Both single and double solenoid valves are provided with the following certifications released by BUREAU VERITAS:

- TYPE APPROVAL certificate according to the EN ISO 13849 regulations
- certification of examination of compliance in accordance to the machinery directive 2006/42/CE

The AIRPLUS SAFELINE are solenoid valves marked as ATEX

II 3G Ex nA IIC T6 Gc (X)  
II 3D Ex tc IIIC T=80°C Dc (X) IP65



### Construction characteristics

Body	Aluminium
Operatore Solenoide	Technopolymer
Rear end cap	Aluminium
Spool	Aluminium
Spool seals	Polyurethane
Piston	Aluminium
Spring	EN 10270-1 DH steel
Electrical Interface	Male MP12 4 PIN TYPE A connector

### Operational characteristics

Fluid	Filtered air. No lubrication needed, if applied it shall be continuous.
Working temperature	-10°C +50°C
Minimum working pressure	2,5 bar
Maximum working pressure	10 bar

### ASSEMBLY AND INSTALLATION:

Undertake the installation respecting the safety requirements with regards to the system and components for hydraulic and pneumatic transmissions. Install the device as close as possible to the point of use. Its assembly is possible in any position. Pay attention to the flow direction, indicated on the main body with the labels IN and OUT. During the components discharge, high levels of noise occur. The use of a silencer on the discharge port is recommended. Ensure there is sufficient space for assembly during the installation process. Please ensure that the discharge area is always clear, and in case a silencer is used, periodically verify that it is not obstructed. It is possible to integrate and install the device in an existing AIRPLUS group or in a new installation, or else to use the device individually attaching it by aligning the assembled unit with the relevant fastening flange for the supply and discharge valve, or to use the device individually attaching it by aligning the assembled unit with the type "Y" fastening flange for the double supply and discharge valve.

2

AIR TREATMENT



**WARNING!**

Pay particular attention to external factors such as the nearness of live wires, magnetic fields, metallic objects providing magnetic conduction very close to the device, which may influence and disturb the diagnostic system.



**WARNING!**

The electrical connection must be made exclusively by specialized personnel, using components that have no voltage present. Only use power supplies which can guarantee a safe electrical isolation of the working voltage in accordance to IEC/EN 60204-1. Additionally, observe the requirements anticipated by the PELV circuits in accordance to IEC/EN 60204-1.

### CARE AND MAINTENANCE



**WARNING!**

Do not connect or disconnect the device when energised! Do not open and/or disassemble the parts that are included in the energised valve. Once the power supply is disconnected, wait for a few minutes before opening or disassembling parts of the valve that result in its disassembly.

Before carrying out any operation, it is essential to remove the pneumatic and power supply to the device and wait for the residual pressure to be completely discharged.

Please ensure that the discharge is always clear, and in case a silencer is used, periodically verify that it is not obstructed.

Periodically remove any dust deposits from the valve using a damp cloth. Use soapy water to clean the device.

Do not use corrosive or alcohol-based products.

For maintenance operations on internal components, please consult with PNEUMAX SPA.

Supply and discharge valve single (VS)

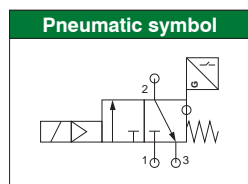

ATEX  $\text{CE}$   $\text{II}$   
**II 3G Ex nA IIC T6 Gc (X)**  
**II 3D Ex tc IIIC T=80°C Dc (X) IP65**



**Electrical connection**

PIN	Description
1	+24 VDC (Sensor)
2	+24 VDC (EV)
3	GND (Sensor+EV)
4	SENSOR OUTPUT

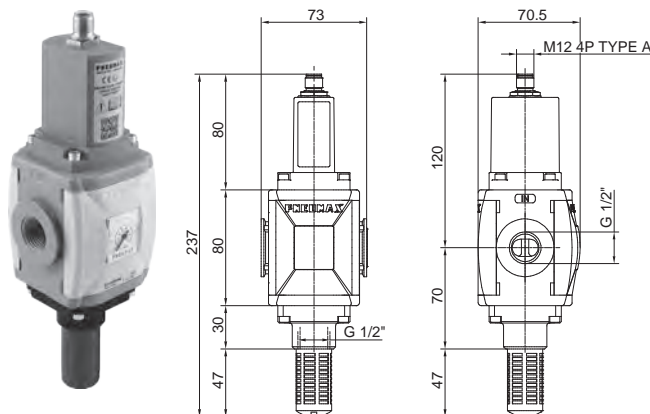
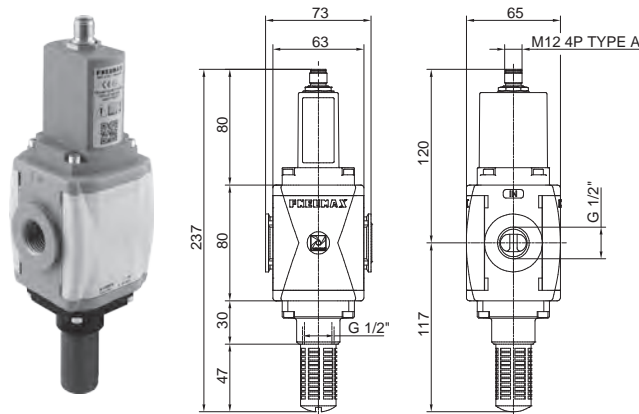
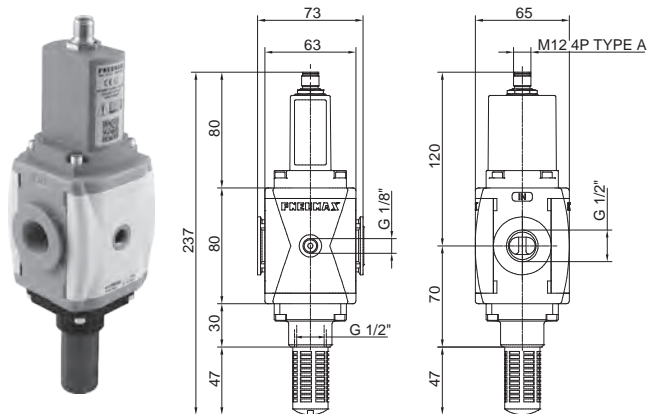

**Dimensions with fixing bracket mounted**

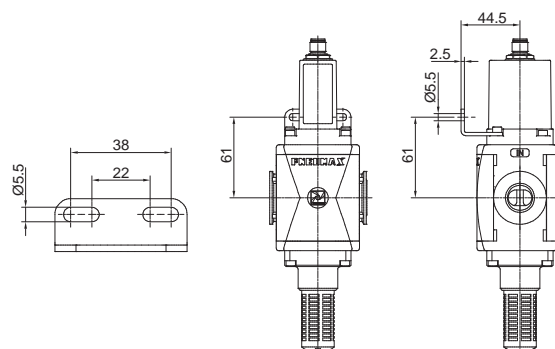

2

AIR TREATMENT

Electrical characteristics		Technical characteristics		Ordering code
Electrical connection	Male M12 4 PIN TYPE A connector	Connections	G1/2" UNI-ISO 228/1	<b>N173BVS00</b>
Coil Features	24VDC, 1 Watt	Fluid	Filtered air. No lubrication needed, if applied it shall be continuous.	VERSIONS
Suppressor diode for coil reverse voltage spike	Present			= Standard* (without connections) <b>M</b> = Integrated pressure gauge <b>W</b> = Integrated pressure gauge (Right-Left) <b>G</b> = G1/8" pressure gauge connection
Supply voltage allowance	-5% +10%	Function	3/2 N.C. monostable	<b>V</b> = Without fixing* <b>F</b>
<b>Electrical characteristics of sensor</b>		Minimum working pressure	2,5 bar	<b>01</b> = Fixing bracket mounted (Left-Right) <b>02</b> = Fixing bracket mounted (Right-Left)
Sensor characteristics	10 - 30V DC	Maximum working pressure	10 bar	
Operating principle	Hall effect	Working temperature	-10°C +50°C	* no additional letter required
Contact type	N.O.	Flow rate at 6bar $\Delta p$ (from 1 to 2)	3500 NL/min	
Output type	PNP	Flow rate at 6bar $\Delta p$ (from 2 to 3)	2000 NL/min	
Permanent maximum current	100 mA	Flow rate at 6bar (from 2 to 3) with free discharge	3800 NL/min	
Permanent maximum power	3 Watt	Type of installation	Stand alone	
Voltage drop max.	2 V	Assembly positions	Indifferent	
<b>Safety characteristics</b>		Noise level	90 dB	
Regulatory compliance	EN ISO 13849-1	Response time ON ISO 12238	36 ms	
Safety function fulfilled	Interruption of supply and unloading of the downstream pneumatic circuit	Response time OFF ISO 12238	76 ms	
Performance Level (PL)	c	IP Rating	IP65 (with connector installed)	
UNI EN 13849 category	2			
Safety Integrity Level (SIL)	1			
PFH <sub>d</sub>	1,7*10 <sup>-6</sup>			
CE marking	In accordance with the EU Machinery Directive, annex V			

**Installation tip of a safety system by means of a single valve**

**Please note: the safety valve is not sufficient alone to guarantee the safety function. Its setup requires the use of a monitoring device.**

In this setup, the SIEMENS® 3SK1112-1BB40 monitoring device has been indicated, activated by an S2 start / reset pushbutton, blocked by an S1 emergency shutdown key.

Said monitoring device, by means of the readings of the sensor placed inside the valve (reading made by means of the K1 relay), operates the activation of the valve itself. The monitoring device transmits the safety status as an output.

The preliminary estimate and the final verification of the achieved PL are the responsibility of the designer of the part of the system dedicated to providing the safety function.

**Note: with a single valve, it is not possible to obtain a PL greater than “c”.**

**Setup suggestions**

- The double stop pushbutton is connected to clamps T1-IN1 and T2-IN2 of 3SK1112-1BB40.
- The start / reset pushbutton is connected between +24 V and the INS clamp of 3SK1112-1BB40.
- The valve is supplied between 0 V (Pin 3 of the supply connector) and the 14 clamp of 3SK1112-1BB40 (Pin 2 of the supply connector).
- The HALL effect sensor is supplied between 0 V (Pin 3 of the supply connector) and 24 V (Pin 1 of the supply connector).
- The HALL effect sensor drives (Pin 4 of the supply connector) the K1 relay, whose N.A. contact will be connected between the monitoring device's clamp T2 and INF.

The circuit diagram of the **suggested** configuration is provided, along with the configuration of 3SK1112-1BB40.

2

AIR TREATMENT

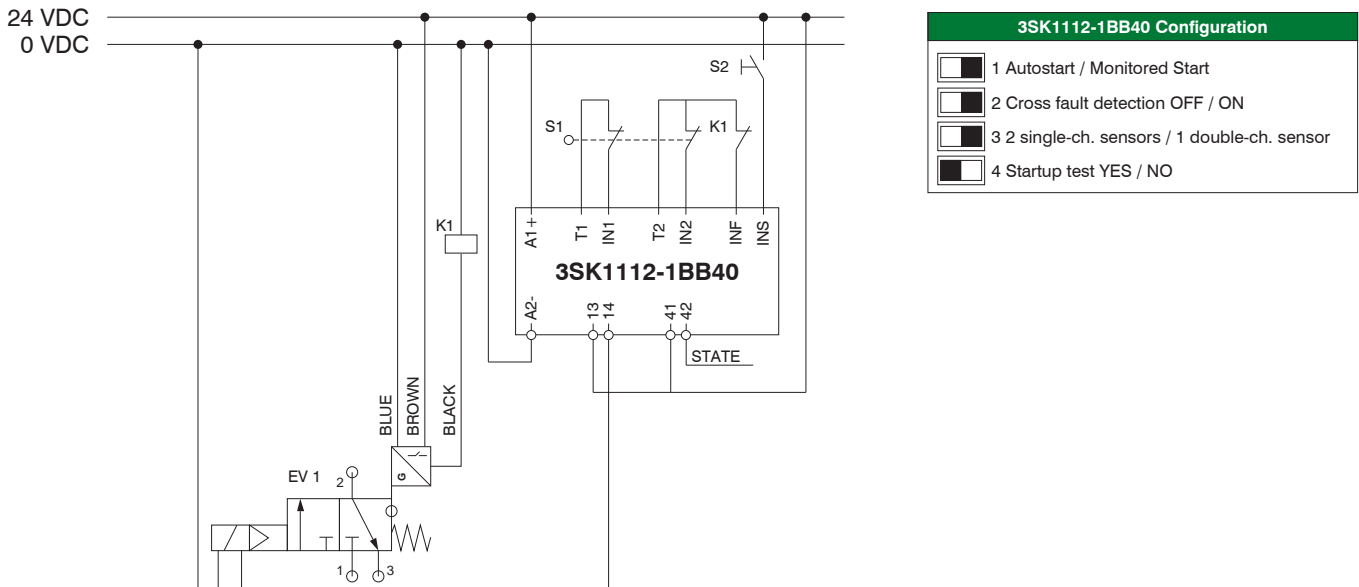

**Analysis of malfunctions**

The diagnostic system (monitoring device plus sensor) has the purpose of verifying the appearance of malfunctions within the valve that undermine the safety function. In particular, (with 3SK1112-1BB40 configured as in the illustration), the K1 relay prevents resetting the system by means of S2 when the coil is de-energised, but the sensor remains in the OFF position (K1 remains de-energised).

Supply and discharge valve double (V2S)

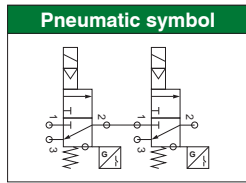

ATEX  $\text{CE}$   $\text{Ex}$   
II 3G Ex nA IIC T6 Gc (X)  
II 3D Ex tc IIIC T=80°C Dc (X) IP65



Electrical connection

PIN	Description
1	+24 VDC (Sensor)
2	+24 VDC (EV)
3	GND (Sensor+EV)
4	SENSOR OUTPUT

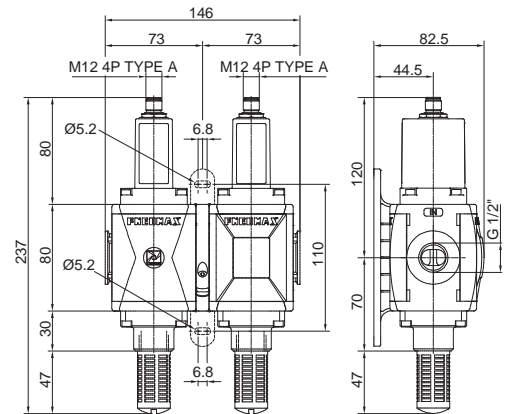
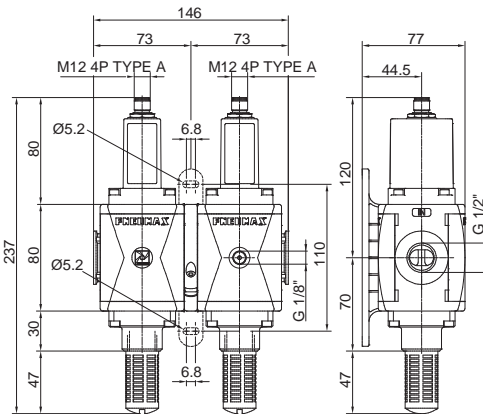
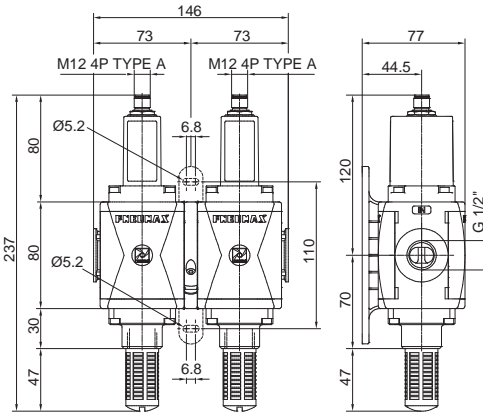

2

AIR TREATMENT

Electrical characteristics		Technical characteristics		Ordering code
Electrical connection	Male M12 4 PIN TYPE A connector	Connections	G1/2" UNI-ISO 228/1	<b>N173BV2S000</b>  VERSIONS = Standard* (without connections) <b>M</b> = Integrated pressure gauge <b>G</b> = G1/8" pressure gauge connection  FIXING <b>X</b> = Flange X <b>Y</b> = Flange Y <b>K</b> = Aluminium flange Y <b>Z</b> = Aluminium flange X  FLOW RATE DIRECTION <b>D</b> = Standard* (Left-Right) <b>W</b> = (Right-Left)  * no additional letter required
Coil Features	24VDC, 1 Watt + 1 Watt	Fluid	Filtered air. No lubrication needed, if applied it shall be continuous.	
Suppressor diode for coil reverse voltage spike	Present	Function	3/2 N.C. monostable	
Supply voltage allowance	-5% +10%	Minimum working pressure	2,5 bar	
<b>Electrical characteristics of sensor</b>		Maximum working pressure	10 bar	
Sensor characteristics	10 - 30V DC	Working temperature	-10°C +50°C	
Operating principle	Hall effect	Flow rate at 6bar Δp (from 1 to 2)	2500 NL/min	
Contact type	N.O.	Flow rate at 6bar Δp (from 2 to 3)	2000 NL/min	
Output type	PNP	Flow rate at 6bar (from 2 to 3) with free discharge	3800 NL/min	
Permanent maximum current	100 mA + 100 mA	Type of installation	Stand alone	
Permanent maximum power	3 Watt + 3 Watt	Assembly positions	Indifferent	
Voltage drop max.	2 V + 2 V	Noise level	90 dB	
<b>Safety characteristics</b>		Response time ON ISO 12238	68 ms	
Regulatory compliance	EN ISO 13849-1	Response time OFF ISO 12238	79 ms	
Safety function fulfilled	Interruption of supply and unloading of the downstream pneumatic circuit	IP Rating	IP65 (with connector installed)	
Performance Level (PL)	e			
UNI EN 13849 category	4			
Safety Integrity Level (SIL)	3			
PFH <sub>d</sub>	4,7*10 <sup>-6</sup>			
CE marking	In accordance with the EU Machinery Directive, annex V			

**Installation tip of a safety system by means of a double valve**

**Please note: the safety valve is not sufficient alone to guarantee the safety function. Its setup requires the use of a monitoring device.**

In this setup, the SIEMENS 3SK2112 monitoring device has been indicated, activated by an S2 start / reset pushbutton, blocked by an S1 emergency shutdown key. Said monitoring device, by means of the readings of the sensors placed inside the double valve, operates the activation of the valve itself. The preliminary estimate and the final verification of the achieved PL are the responsibility of the designer of the part of the system dedicated to provide the safety function.

**Setup suggestions**

- The double stop pushbutton is connected to clamps T1-F-IN1 and T2-F-IN2 of 3SK2112.
- The start /reset pushbutton is connected between +24 V and the F-IN10 clamp of 3SK2112.

The double valve, for notation simplicity, is indicated as consisting of 2 valves: EV1 and Ev2

**EV1**

- The valve is supplied between 0 V (Pin 3 of the supply connector) and the F-Q1 clamp of 3SK2112 (Pin 2 of the supply connector).
- The HALL effect sensor is supplied between 0 V (Pin 3 of the supply connector) and 24 V (Pin 1 of the supply connector).
- The HALL effect sensor is attached (Pin 4 of the supply connector) to the monitoring device's F-IN3 clamp.

**EV2**

- The valve is supplied between 0 V (Pin 3 of the supply connector) and the F-Q2 clamp of 3SK2112 (Pin 2 of the supply connector).
- The HALL effect sensor is supplied between 0 V (Pin 3 of the supply connector) and 24 V (Pin 1 of the supply connector).
- The HALL effect sensor is attached (Pin 4 of the supply connector) to the monitoring device's F-IN4 clamp.

The circuit diagram of the **suggested** configuration is provided.

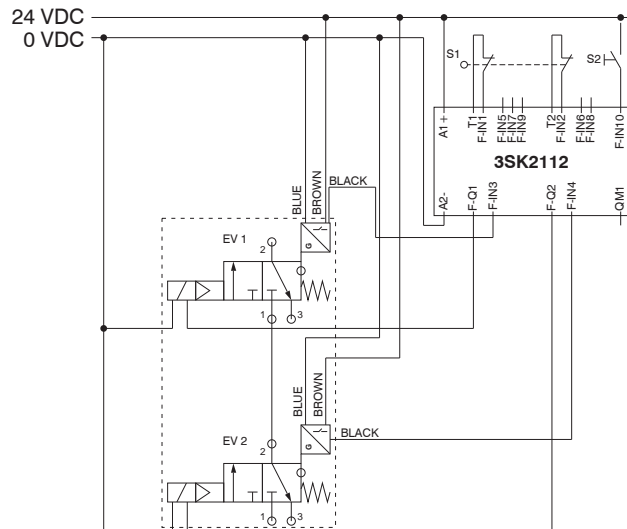

**Analysis of malfunctions**

The diagnostic system (monitoring device plus sensors) has the purpose of verifying the appearance of malfunctions within the valves, which undermine the safety function. In particular, the monitoring device must be appropriately programmed to avoid the system's reset by means of S2 when both coils are de-energised and at least one sensor remains in an OFF position.

**Accessories**

**Pressure gauge**

17070 **A** **C**

Version	
<b>A</b>	Dial Ø40
<b>B</b>	Dial Ø50
Scale	
<b>A</b>	0 - 4 bar
<b>B</b>	0 - 6 bar
<b>C</b>	0 - 12 bar

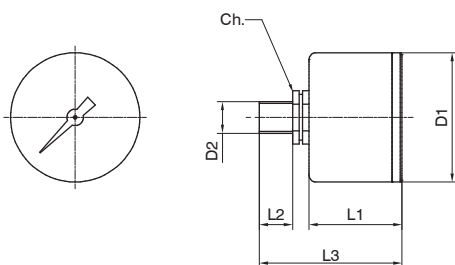

Model	L1	L2	L3	D1	D2	Ch
17070A..	26	10	44	41	Gc - 1/8"	14
17070B..	27	10	45	49	Gc - 1/8"	14



## Regulatory Framework

The purpose of the EU's Machinery Directive is to define the health and safety requirements in the framework of designing and constructing machinery. Since 2009, the new Machinery Directive has become effective in the European Union. Member countries of the EU are required to implement this standard.

The manufacturers of machinery can comply with the Machinery Directive applying the harmonised standards listed in the Official Journal of the European Union.

The design and manufacture of safety controls are developed in compliance with one of the two important harmonised standards:

UNI EN ISO 13849-1
Safety of machinery Safety-related parts of control systems Part 1: General design principles

EN 62061
Safety of machinery Functional safety of electrical, electronic and programmable control systems regarding safety

The UNI EN ISO 13849-1 standard is one of the most important harmonised standards, which has been widely used; it is intended to provide a guide to principles for design and integration of safety-related parts of the control system.

Each safety-related control system must be designed and constructed in accordance with the principles of ISO 12100 and ISO 14121 by which the possible risks are considered and assessed, in view of the intended uses and the reasonably anticipated incorrect uses.

The parts of a machinery's control system are called "Safety-related parts of control systems". Their capacity to perform a safety function under predictable conditions is assigned by means of five possible levels called "performance levels" (PL). These levels are defined in terms of probability of dangerous malfunction per hour.

PL - Performance Level	Average probability of dangerous malfunction per hour (1/h)
a	$\geq 10^{-5}$ to $< 10^{-4}$
b	$\geq 3 \times 10^{-6}$ to $< 10^{-4}$
c	$\geq 10^{-6}$ to $< 3 \times 10^{-6}$
d	$\geq 10^{-7}$ to $< 10^{-6}$
e	$\geq 10^{-8}$ to $< 10^{-10}$

The calculated PL must be greater or equal to the necessary value, which arises from the calculation of the risk correlated to one single function and to the need to reduce it to an acceptable level.

<b>S1</b> Slight danger	<b>F1</b> Occasional danger and brief exposure	<b>P1</b> - possibly avoidable danger <b>P2</b> - largely unavoidable danger	<b>PL= a</b> <b>PL= b</b>
	<b>F2</b> Frequent danger and long exposure	<b>P1</b> - possibly avoidable danger <b>P2</b> - largely unavoidable danger	
<b>S2</b> Serious danger	<b>F1</b> Occasional danger and brief exposure	<b>P1</b> - possibly avoidable danger <b>P2</b> - largely unavoidable danger	<b>PL= c</b> <b>PL= d</b>
	<b>F2</b> Frequent danger and long exposure	<b>P1</b> - possibly avoidable danger <b>P2</b> - largely unavoidable danger	

▶ **Manifold unit**



- ▶ Modular system
- ▶ Compact and linear design
- ▶ Maximum flexibility and reliability
- ▶ Up to 10 items assembly with unlimited configuration
- ▶ Flange coupling plug-n-play configuration
- ▶ Maintenance possible without completely disassembling the group
- ▶ Manifold integrated safety function elements
- ▶ Material and version wide selection
- ▶ Available in 4 sizes with connections from 1/8" to 1"
- ▶ Atex certification (II 2GD or II 3GD)

2 AIR TREATMENT

Operational characteristics		Size	Size 1	Size 2	Size 3	Size 4
Maximum working pressure *		10 bar / 13 bar / 16 bar / 20 bar				
Minimum working pressure *		0,5 bar / 2,5 bar				
Working temperature *		-5°C +50°C / -30°C +80°C / -40°C +80°C				
IN / OUT connections	T version	G1/4"		G3/8"		not available
	N version	G1/8" - G1/4" - 1/4" NPT		G3/8" - G1/4" - 3/8" NPT		
	P and L version	not available		G3/8" - 1/4" NPT		G1" - 1" NPT
Assembly configuration		Stand alone Panel mounted thru fixing elements				
Assembly positions		Vertical ±5° with no restriction in case of elements without bowl				
Max. fittings torque IN / OUT connections		G1/8" metal: 15Nm G1/4" metal: 20Nm G1/4" technopolymer: 9Nm	G1/4" metal: 20Nm G3/8" metal: 25Nm G3/8" technopolymer: 16Nm	G3/8" metal: 25Nm G1/2" metal: 30Nm G1/2" technopolymer: 22Nm	G1" metal: 35Nm	
Max. fittings torque G1/8" pressure gauge connection		G1/8" metal: 15Nm G1/8" technopolymer: 4Nm				



\* Module configuration shall be identified according to individual technical details of each items included in applicable manifold

**Manifold assembly**

The assembly operation of selected items (module) is carried out thru dedicated quick connection flanges. Both aluminum and techno polymer materials selection available, with fixing holes in case of panel mounting configuration. Due to its design, Pneumax connection flanges allow user-friendly maintenance activities with no need of entire manifold disassembling procedure.



Thanks to a wide range of modules with different functions and characteristics, together with a wide choice of materials selection, make the Pneumax AIRPLUS air treatment units a robust, reliable and extremely flexible modular system, adaptable to different applications. AIRPLUS units properly assembled are modular with unlimited configurations and solutions and capable to satisfy and fulfill all their functions of compressed air treatment. Pneumax Airplus air treatment units can be integrated with safety elements that comply with EN-ISO 13849-1 and CE marking according to EU Machinery Directive, Annex V. Simple instruction provides an easy manifold configuration.





**Configuration instructions**

Manifold configuration as per following instructions.  
As a result, a dedicated code will be provided, and the two main parameters will be identified, as follow:  
Features applicable to all items included in manifold (i.e. version, size, connection, flow direction)  
Assembly sequence of the single item + coupling flanges  
Note: Max 10 items for each manifold.

The group can be configured by consulting the Pneumax catalog here:  
<http://pneumax.partcommunity.com/3d-cad-models/>  
also reachable through a special link available on the home page of the Pneumax website



**Order codes**

Initial code that identifies the main characteristics of the group such as:  
- version  
- size and connections  
- flow direction  
These will be the same for all the modules included in manifold, in accordance with the characteristics of the individual items available

Code that identifies the succession of individual modules and related coupling flanges included in manifold from module 1 to 10

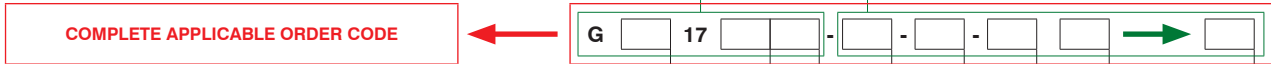

Version	
N	: Technopolymer body and metal inserts (not available for size 4)
T	: Technopolymer body and thread (not available for size 4)
P	: Aluminum body (not available for size 1)
L	: Aluminum body, low temperature (not available for size 1)

Size and connections	
1A	: Size 1 - G1/8" only for N version
1B	: Size 1 - G1/4" only for T - N versions
1C	: Size 1 - 1/4" NPT only for N version
2A	: Size 2 - G1/4" only for N version
2B	: Size 2 - G3/8" for all versions
2C	: Size 2 - 3/8" NPT only for N version - 1/4" NPT only for P - L versions
3A	: Size 3 - G3/8" only for N version
3B	: Size 3 - G1/2" for all versions
3C	: Size 3 - 1/2" NPT only for N - P - L versions
4B	: Size 4 - G1" only for P - L versions
4C	: Size 4 - 1" NPT only for P - L versions

Flow direction	
	: From left to right
W	: From right to left

Module 1	
	See list of modules

Mounting hardware 1	
X	: Technopolymer flange X
Y	: Technopolymer flange Y
K	: Aluminium flange X
T	: Aluminium flange Y

Module 2	
	See list of modules

Mounting hardware 1	
X	: Technopolymer flange X
Y	: Technopolymer flange Y
K	: Aluminium flange X
T	: Aluminium flange Y

Module 10	
	See list of modules



2 AIR TREATMENT



**List of modules**

Below the list of modules available for assembly of the manifold

<b>FILTER</b>	<b>F</b>	A : 5 µm B : 20 µm C : 50 µm	: Semi-automatic drain S : Automatic drain	: Technopolymer protection - PC bowl N : Technopolymer protection - PA bowl P : Metal protection - PC bowl R : Metal protection - PA bowl T : Metal bowl					
<b>COALESCING FILTER</b>	<b>DA</b>		: Semi-automatic drain S : Automatic drain	: Technopolymer protection - PC bowl N : Technopolymer protection - PA bowl P : Metal protection - PC bowl R : Metal protection - PA bowl T : Metal bowl					
<b>OIL REMOVAL FILTER</b>	<b>D</b>	AV : Size 4 BV : Size 3 CV : Size 3 oversize cartridge	: Semi-automatic drain S : Automatic drain	: Technopolymer protection - PC bowl N : Technopolymer protection - PA bowl P : Metal protection - PC bowl R : Metal protection - PA bowl T : Metal bowl					
<b>CARBON FILTER</b>	<b>DD</b>			: Technopolymer protection - PC bowl N : Technopolymer protection - PA bowl P : Metal protection - PC bowl R : Metal protection - PA bowl T : Metal bowl					
<b>REGULATOR</b>	<b>R</b>	: G1/8" connection M : Integrated pressure gauge W : Integrated pressure gauge Right - Left P : Digital pressure switch Z : Digital pressure switch Right - Left	A : 0-2 bar B : 0-4 bar C : 0-8 bar D : 0-12 bar	: With relieving and improved relieving L : Without relieving R : Improved relieving	: Standard knob K : Lockable knob	A : Cable 150mm M8 PNP B : Cable 150mm M8 NPN C : Cable 2m PNP D : Cable 2m NPN			
<b>FILTER REGULATOR</b>	<b>E</b>	: G1/8" connection M : Integrated pressure gauge W : Integrated pressure gauge Right - Left P : Digital pressure switch Z : Digital pressure switch Right - Left	A : 5 µm B : 20 µm C : 50 µm	A : 0-2 bar B : 0-4 bar C : 0-8 bar D : 0-12 bar	: Semi-automatic drain S : Automatic drain	: With relieving L : Without relieving	: Standard knob K : Lockable knob	A : Cable 150mm M8 PNP B : Cable 150mm M8 NPN C : Cable 2m PNP D : Cable 2m NPN	: Technopolymer protection - PC bowl N : Technopolymer protection - PA bowl P : Metal protection - PC bowl R : Metal protection - PA bowl T : Metal bowl
<b>LUBRICATOR</b>	<b>L</b>		: No electric level sensor device A : Electrical minimum level sensor NO C : Electrical minimum level sensor NC					: Technopolymer protection - PC bowl N : Technopolymer protection - PA bowl P : Metal protection - PC bowl R : Metal protection - PA bowl	
<b>SHUT OFF VALVE</b>	<b>V</b>	L : Manual P : Pneumatic E : Solenoid		<b>15mm coil</b> A4 : 12 V DC A5 : 24 V DC A6 : 24 V AC (50-60 Hz) A7 : 110 V AC (50-60 Hz) A8 : 230 V AC (50-60 Hz) A9 : 24 V DC (1 Watt) <b>22mm coil</b> B2 : Mechanical M2, without coil B4 : 12 V DC B5 : 24 V DC B6 : 24 V AC (50-60 Hz) B7 : 110 V AC (50-60 Hz) B8 : 230 V AC (50-60 Hz) B9 : 24 V DC (2 Watt) <b>30mm coil</b> C5 : 24 V DC C6 : 24 V AC (50-60 Hz) C7 : 110 V AC (50-60 Hz) C8 : 230 V AC (50-60 Hz) C9 : 24 V DC (2 Watt)					
<b>SAFETY VALVE</b>	<b>V</b>	S : Single 2S : Double		: Without connection M : Integrated pressure gauge W : Integrated pressure gauge (Right - Left) G : G1/8" pressure gauge connection			X = Flange X Y = Flange Y K = Aluminium flange Y Z = Aluminium flange X		
<b>PROGRESSIVE START-UP VALVE</b>	<b>AP</b>	: Size 1 - Size 2 - Size 3 W : Size 4 - flow direction Right - Left							
<b>AIR INTAKE</b>	<b>PA</b>								
<b>AIR INTAKE WITH PRESSURE GAUGE OR DIGITAL PRESSURE SWITCH INTEGRATED</b>	<b>P</b>		M : Integrated pressure gauge W : Integrated pressure gauge (Right - Left) P : Integrated digital pressure switch Z : Integrated digital pressure switch (Right - Left)				A : Cable 150mm M8 PNP B : Cable 150mm M8 NPN C : Cable 2m PNP D : Cable 2m NPN		
<b>PRESSURE SWITCH</b>	<b>PP</b>	: Size 1 - Size 2 - Size 3 W : TG4 - flow direction Right - Left							

Examples of module identification: 5µm filter, automatic drain, metal bowl is identified as: **F A S T**

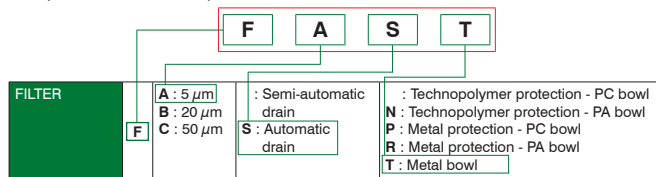

- Filter regulator with pressure gauge 50µm, 0-12 bar semi-automatic drain, without relieving, technopolymer bowl protection, PA bowl, is identified as: **E M C D L N**

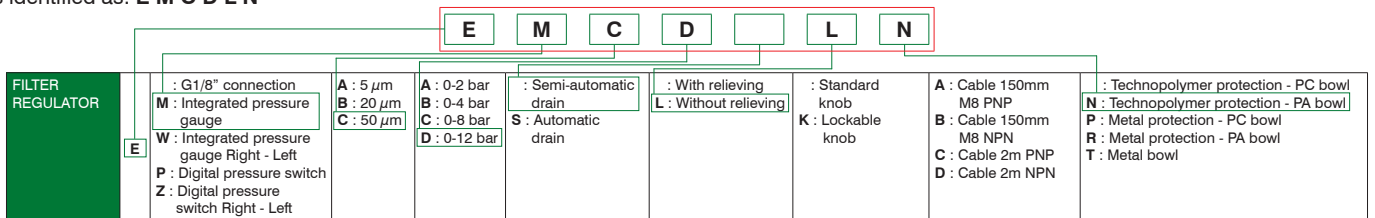

### AIRPLUS assembled groups configuration

Configuration sample:

- Shut off valve
- Filter regulator, 20µm, 0-12bar, automatic drain
- Lubricator with electrical minimum level sensor NO
- Electric shut off valve, 22mm, without coil
- Progressive start-up valve

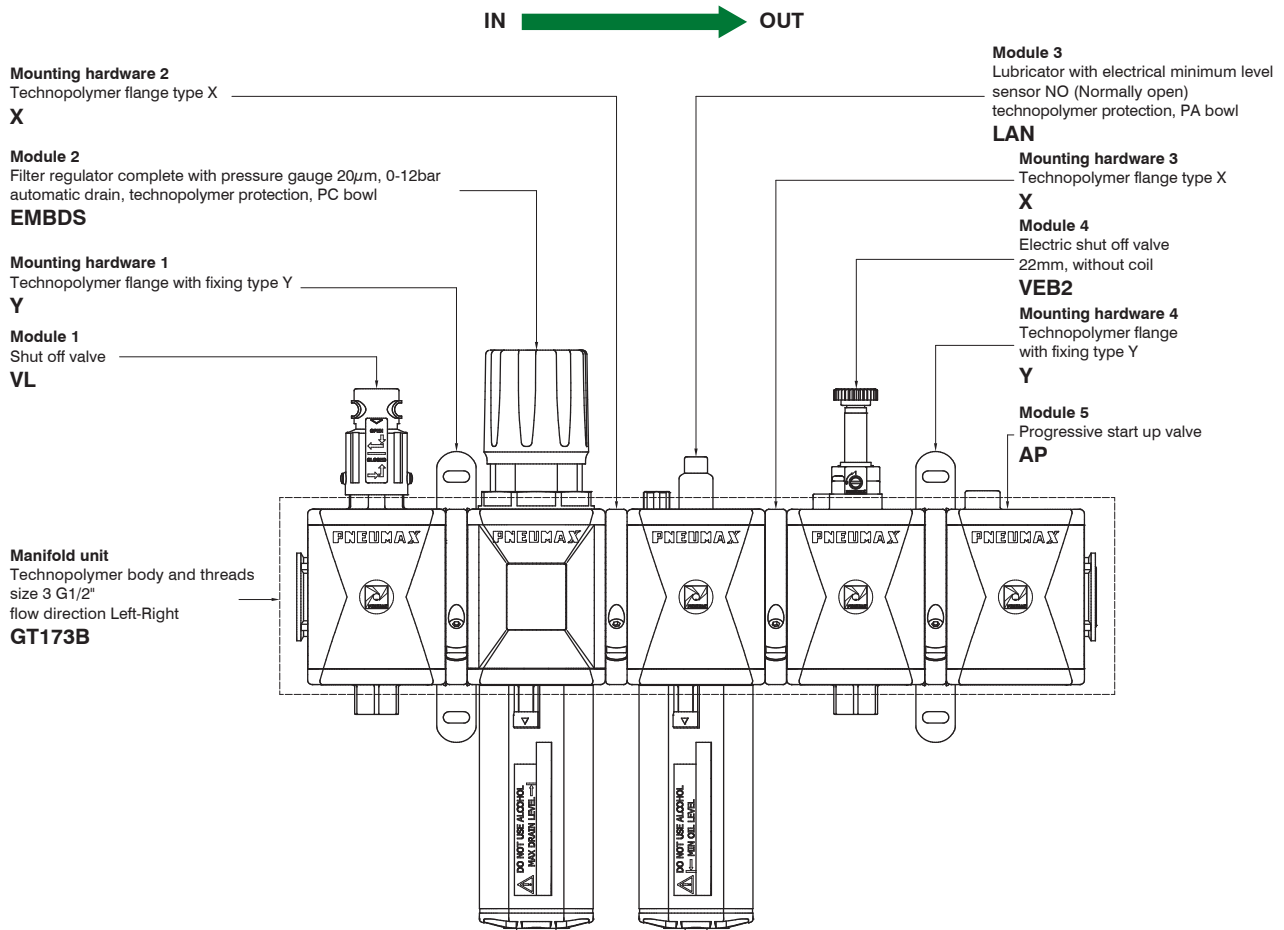

2

AIR TREATMENT

Applicable order code:

Initial code that identifies the main characteristics of the group such as:  
- version  
- size and connections  
- flow direction  
These will be the same for all the modules included in manifold, in accordance with the characteristics of the individual items available

Code that identifies the succession of individual modules and related coupling flanges included in manifold from module 1 to 10

G T 17 3B - VL - Y - EMBDS - X - LAN - X - VEB2 - Y - AP



**GT173 - VL - Y - EMBDS - X - LAN - X - VEB2 - Y - AP**

**Flanges positioning schematic**

Here below some indications related to flanges positioning according to the number of seats. Pneumax recommend configuration in compliance with the following schematic:

Group 2 seats



Group 3 seats

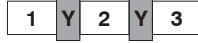

Group 4 seats

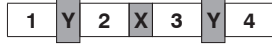

Group 5 seats



Group 6 seats



Group 7 seats

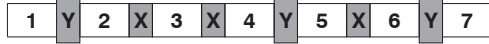

Group 8 seats



Group 9 seats



Group 10 seats



Y: Y type flange (Aluminium or technopolymer)  
X: X type flange (Aluminium or technopolymer)  
1 - 10 : AIRPLUS modules

2  
AIR TREATMENT

**Quick coupling flanges**

Pneumax Airplus quick coupling flanges series allow both module rapid fixing and panel mounted configuration. Due to its design, Pneumax connection flanges allow user-friendly maintenance activities with no need of entire manifold disassembling procedure. Two types of flange are available: X type flange for assembling the modules together, and Y type flange suitable for panel mounted also. Both types are made of technopolymer or die-cast aluminum.

► **Technopolymer flanges**

Flange Y

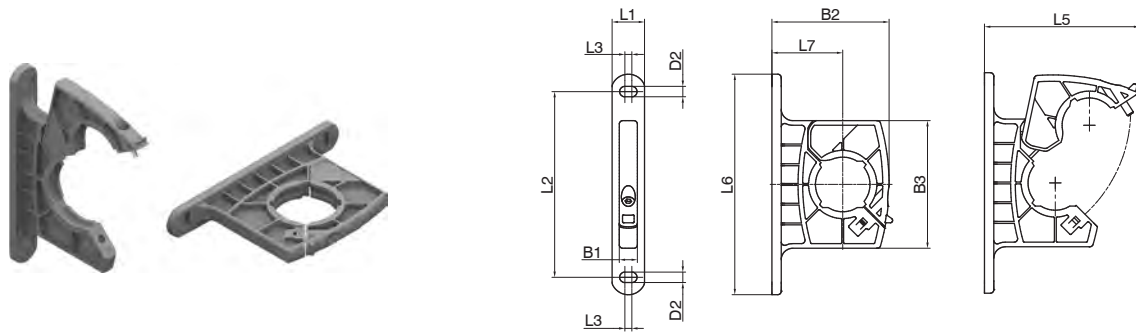

Flange X

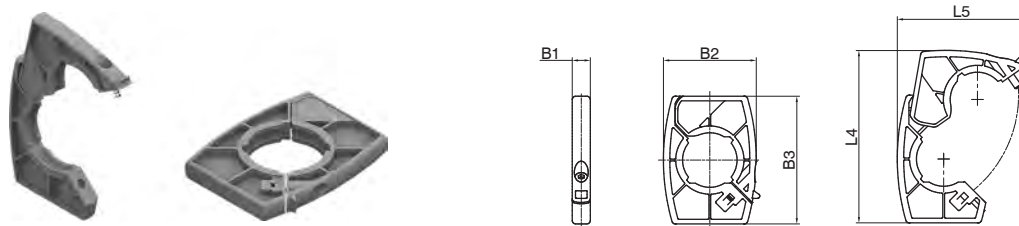

Model	B1	B2	B3	D2	L1	L2	L3	L4	L5	L6	L7
T171Y	7,8	50,5	55	Ø4,5	14	80	3	/	66	95	30,5
T171X		40		/	/	/	/	74,5	55,5	/	/
T172Y	9,7	67,6	68	Ø5,2	18	95	6,8	/	86,5	117,9	40,5
T172X		53,6		/	/	/	/	96,5	72,5	/	/
T173Y	9,7	75,5	80	Ø5,2	18	110	6,8	/	98,3	133	44,5
T173X		62		/	/	/	/	112,8	85	/	/
T174Y	13,7	106,5	105	Ø8,5	25	148	6,5	/	133,5	175	64
T174X		85		/	/	/	/	153,5	112	/	/

► **Aluminium flanges**

Flange Y

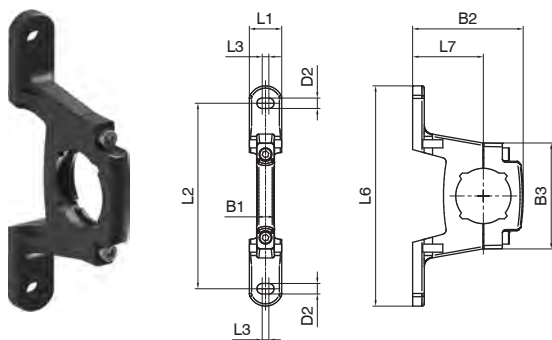

Flange X

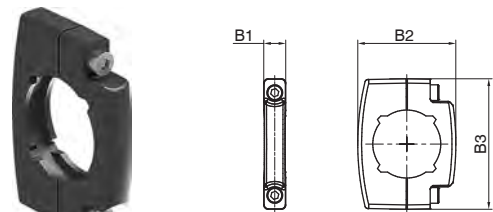

Model	B1	B2	B3	D2	L1	L2	L3	L4	L5	L6	L7
N171Y	7,8	47,7	45,7	Ø4,5	14	80	3	/	66	95	30,5
N171X		34,4		/	/	/	/	74,5	55,5	/	/
N172Y	9,7	64,6	55,6	Ø5,2	18	95	6,8	/	86,5	117,9	40,5
N172X		55,6		/	/	/	/	96,5	72,5	/	/
N173Y	9,7	75,5	56	Ø5,2	18	110	6,8	/	98,3	133	44,5
N173X		62		/	/	/	/	112,8	85	/	/
N174Y	13,7	106,5	102	Ø8,5	25	148	6,5	/	133,5	175	64
N174X		85		/	/	/	/	153,5	112	/	/



**Product overview**

2 AIR TREATMENT

PRODUCT	BODY MATERIAL	SIZES AND CONNECTIONS			
		SIZE 1	SIZE 2	SIZE 3	SIZE 4
FILTER	Zinc alloy	G1/8" - G1/4"	/	/	/
	Technopolymer	G1/8" - G1/4"	/	/	/
	Aluminum	/	G1/4" - G3/8"	G3/8" - G1/2" - G 3/4"	G1"
DYNAMIC DRIER	Aluminum	/	/	/	G1"
FILTER REGULATORS	Zinc alloy	G1/8" - G1/4"	/	/	/
	Technopolymer	G1/8" - G1/4"	/	/	/
	Aluminum	/	G1/4" - G3/8"	G3/8" - G1/2" - G 3/4"	/
REGULATORS	Zinc alloy	G1/8" - G1/4"	/	/	/
	Technopolymer	G1/8" - G1/4"	/	/	/
	Aluminum	/	G1/4" - G3/8"	G3/8" - G1/2" - G 3/4"	G1"
REGULATORS WITH INTEGRATED PRESSURE GAUGE	Zinc alloy	G1/8" - G1/4"	/	/	/
	Technopolymer	G1/8" - G1/4"	/	/	/
	Aluminum	/	G1/4" - G3/8"	G3/8" - G1/2"	/
HIGH SENSITIVE AIR PRESSURE REGULATORS WITH HIGH FLOW RATE RELIEVING	Aluminum	G1/4"	/	G1/2"	/
HIGH SENSITIVE PRESSURE REGULATOR WITH PNEUMATIC PILOT	Aluminum	/	/	G1/2"	/
PILOTED PRESSURE REGULATORS	Aluminum	/	G1/4" - G3/8"	G3/8" - G1/2"	G1"
PANEL MOUNTING PRESSURE REGULATOR	Technopolymer	G1/8" - G1/4"	/	/	/
PRESSURE REGULATORS FOR MANIFOLD	Zinc alloy	G1/8" - G1/4"	/	/	/
MANIFOLD PRESSURE REGULATORS	Zinc alloy	G1/8" - G1/4"	/	/	/
LUBRICATORS	Zinc alloy	G1/8" - G1/4"	/	/	/
	Technopolymer	G1/8" - G1/4"	/	/	/
	Aluminum	/	G1/4" - G3/8"	G3/8" - G1/2" - G 3/4"	G1"
SHUT-OFF VALVE	Zinc alloy	G1/4"	/	/	/
	Technopolymer	G1/4"	/	/	/
	Aluminum	/	G3/8"	G1/2"	G1"
ELECTRIC SHUT-OFF VALVE	Zinc alloy	G1/4"	/	/	/
	Technopolymer	G1/4"	/	/	/
	Aluminum	/	G3/8"	G1/2"	/
PNEUMATIC SHUT-OFF VALVE	Zinc alloy	G1/4"	/	/	/
	Technopolymer	G1/4"	/	/	/
	Aluminum	/	G3/8"	G1/2"	/
PROGRESSIVE START-UP VALVE	Aluminum	G1/4"	G3/8"	G1/2"	G1"
AIR INTAKE	Aluminum	G1/4"	G3/8"	G1/2"	G1"
AIR INTAKE -"H" PROFILE	Aluminum	G1/4"	G3/8"	G1/2"	/
PRESSURE SWITCH COMPLETE WITH ADAPTER	Aluminum	G1/8"	G3/8"	G1/2"	Ø36

## Air service units, series 1700

- Modular sistem
- Available for 4 sizes with connections from 1/8" to 1"
- ATEX certification (II 2GD o II 3GD) on request



### Construction and working characteristics

1700 air treatment series includes a wide range of elements for individual use or modular assembling.

Available in 4 sizes e connections from 1/8" to 1".

The bowls are made in zinc alloy body with zinc alloy integrated connections, technopolymer with integrated metal connections for size 1 and aluminium with integrated aluminium connections for sizes 2, 3 and 4.

The bowls are in Nylon, with technopolymer protection for sizes 1, 2, 3 (also available for size 1 without protection). The bowls are in metal with condensation drain display for size 4.

Filters can be equipped with manual or semiautomatic condensation drain; furthermore it's possible to install the automatic draining device inside the bowl.

Wall mounting by means of screws directly through the body and hidden by protective covers.

The pressure regulator handle is lockable in the desired position, the shut-off valves are lockable with a maximum of three pad-locks to prevent accidents or damages due to unauthorized operation.

The lubricator oil flow is adjustable with proper handle and it is visibly checked through the sight dome.

The progressive start-up valve, pneumatically or electropneumatically controlled, allows air supply to the circuit progressively and with adjustable time. The accessories like panel mounted brackets, pressure gauges with different scales and diameters and the air intake blocks are completing the range. They are assembled between the elements to get filtered or filtered non-lubricated air in the system.

### Instruction for installation and operation

Pay attention to install a group or a single component with air flow direction according to the arrows and to the following sequence: filter, pressure regulator, lubricator and with bowls downwards. The group can be fixed to the wall by removing the covers, which can be installed again after fixing for covering the screws. Do not exceed the recommended torque while assembling the connectors.

Do not exceed the recommended air pressure and temperature limits. The moisture should not exceed the level marked on the bowl and it can be drawn off and carried by a flexible tube of Ø 6/4 directly connected to the discharge valve handle.

The pressure should be set from minimum to maximum, rotating the adjusting handle clockwise.

As lubricant, we suggest to use oil class FD22 or HG32. Verify that the lubricator is not fed with a flow lower than the minimum operational.

To set the oil flow rotate the proper adjusting handle in order to get one drop of oil every 300-600 liters of air.

The oil flow will be kept automatically and proportionally to the air flow. The oil can be refilled by mean of proper plug or directly into the bowl after having de-pressurized the system. Do not exceed the maximum level indicated on the bowl. For opening the shut-off valve push and rotate clockwise the operating handle. For closing it and consequently discharging the down stream line, rotate the handle counter-clockwise.

### Maintenance

Clean the bowls with water and detergent. Do not use alcohol.

The filter element made with HPDE is reusable by blowing and cleaning it with proper detergent. For replacing or cleaning it, remove the bowl and unscrew the baffle spins.

Replace the pressure regulator diaphragm whenever the operation is not correct or there is a continuous air leaking through the relieving (over pressure discharge); reinstall the adjusting mechanism support, locking it with about 8 Nm torque. In case it is necessary to replace the lubricator transparent dome, tight it at 5 Nm torque maximum.

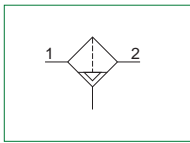
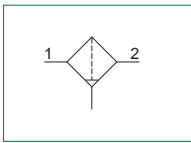

- ▶ Double filter action: air flow centrifugation and filter element
- ▶ Available in 4 sizes with flow rates up to 10000 NI/min and connections from 1/8" to 1"
- ▶ Filtering cartridge made of HDPE available in three different filtration grades (5µm, 20µm, 50µm)
- ▶ Filter cartridge can be regenerated by washing / blowing it or replaced
- ▶ Bowls screwed to the body (Size 1)
- ▶ Bowl assembly via bayonet type quick coupling mechanism with safety button (Size 2 - Size 3 - Size 4)
- ▶ Semi-automatic or automatic condensation drain
- ▶ Atex certification (II 2GD o II 3GD) on request

**AIR TREATMENT**

**Note**  
 In order to ensure that any fluid discharged by the auto drain assembly is adequately drained away, it is recommended you to use a 6mm fitting and tube

Technical characteristics	Size			
	Size 1	Size 2	Size 3	Size 4
<b>Body and connections type</b>	Zinc alloy body, Zinc alloy integrated connections Technopolymer body, metal connections	Aluminium body, integrated aluminium connections		
<b>Protection and bowl type</b>	Technopolymer protection - PA bowl (Size 1 available without protection)			Metal bowl with blind metal bowl
<b>IN / OUT connections</b>	G1/8" - G1/4"	G1/4" - G3/8"	G3/8" - G1/2", G3/4"	G1"
<b>Assembly configuration</b>	Stand alone Panel mounted with M4 screws	Stand alone Panel mounted with M5 screws	Stand alone Panel mounted with M6 screws	Stand alone Panel mounted with M8 screws
<b>Assembly position</b>	Vertical ±5°			
<b>Filter pore size (µm)</b>	5 / 20 / 50			
<b>Bowl capacity (cm³)</b>	20	30	48	178
<b>Condensation drain</b>	Semi-automatic Automatic			
<b>Max. fittings torque IN / OUT connections</b>	G1/8" metal: 15 G1/4" metal: 20	G1/4" metal: 20 G3/8" metal: 25	G3/8" metal: 25 G1/2" metal: 30 G3/4" metal: 35	G1" metal: 35

Operational characteristics	Size							
	Size 1	Size 2	Size 3	Size 4	Size 1	Size 2	Size 3	Size 4
	Semi-automatic condensation drain				Automatic condensation drain			
<b>Maximum working pressure (bar)</b>	13				10			
<b>Minimum working pressure (bar)</b>	0,5							
<b>Working temperature (°C)</b>	-5 ÷ +50							

Weights	Size			
	Size 1	Size 2	Size 3	Size 4
Zinc alloy body version (g)	218	/	/	/
Technopolymer body version (g)	103	/	/	/
Aluminium body version (g)	/	255	405	1700





Order codes

17 301A . A . S

Size, body and connections
001A : Zinc alloy body, connections G1/8" (only for size 1)
001B : Zinc alloy body, connections G1/4" (only for size 1)
101A : Technopolymer body, connections G1/8" (only for size 1)
101B : Technopolymer body, connections G1/4" (only for size 1)
201A : Aluminium body, connections G1/4" (only for size 2)
201B : Aluminium body, connections G3/8" (only for size 2)
301A : Aluminium body, connections G3/8" (only for size 3)
301B : Aluminium body, connections G1/2" (only for size 3)
301E : Aluminium body, connections G3/4" (only for size 3)
401B : Aluminium body, connections G1" (only for size 4)

Filter pore size
A : 5 $\mu\text{m}$
B : 20 $\mu\text{m}$
C : 50 $\mu\text{m}$

Type
P : Bowl protection (only for size 1)
S : Automatic drain (for all sizes)
PS : Bowl protection and automatic drain (only for size 1)

**Example: 17301A.A.S**

Size 3 filter, aluminium body, G3/8" connections, filter pore size 5  $\mu\text{m}$ , automatic drain

**Dimensions**

2  
AIR TREATMENT

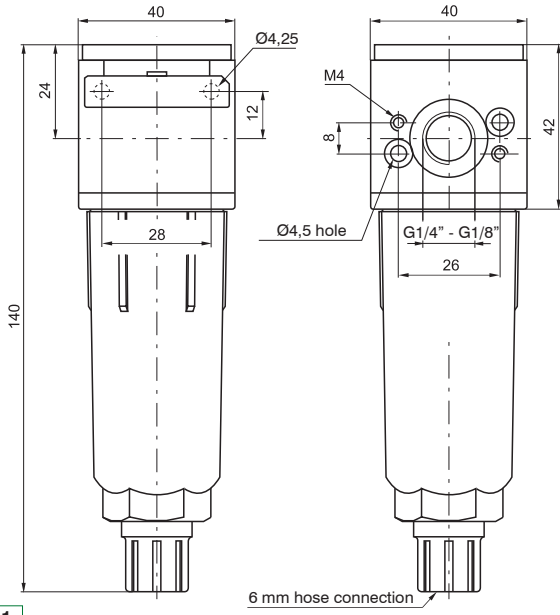

**Size 1**

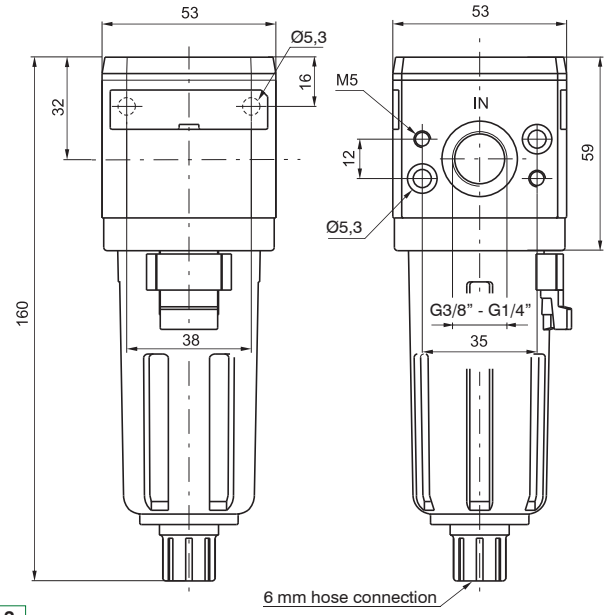

**Size 2**

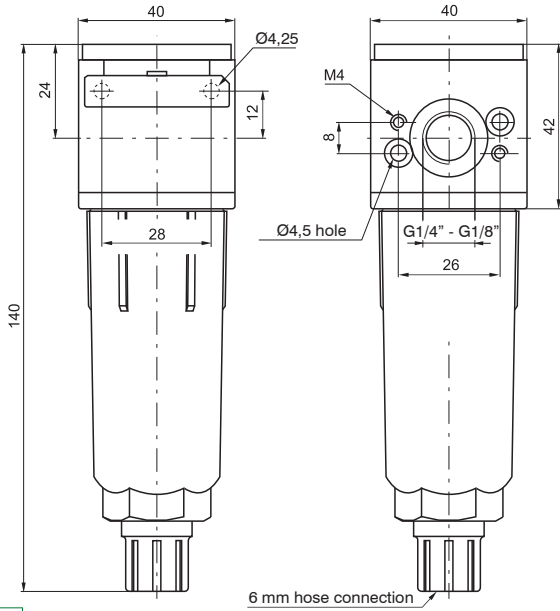

**Size 3**

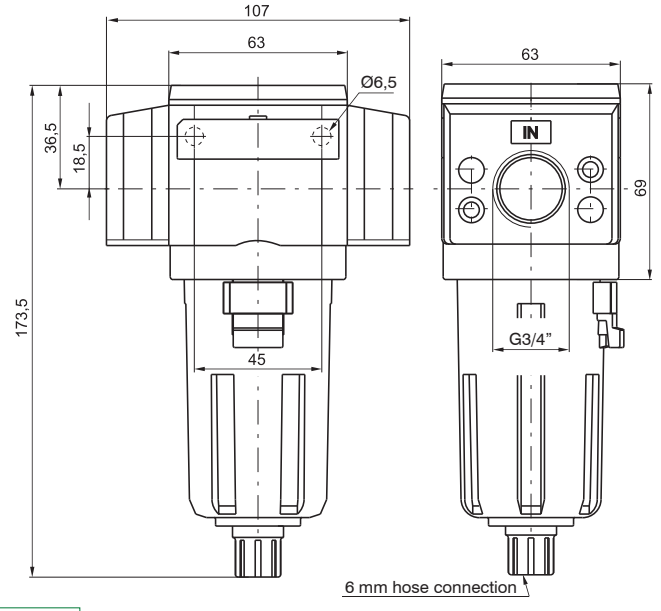

**Size 3 3/4"**

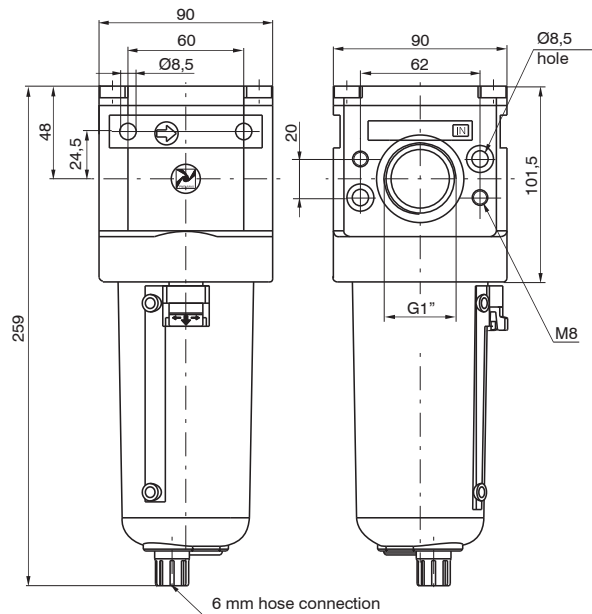

**Size 4**



Characteristic curves

Flow rate curves

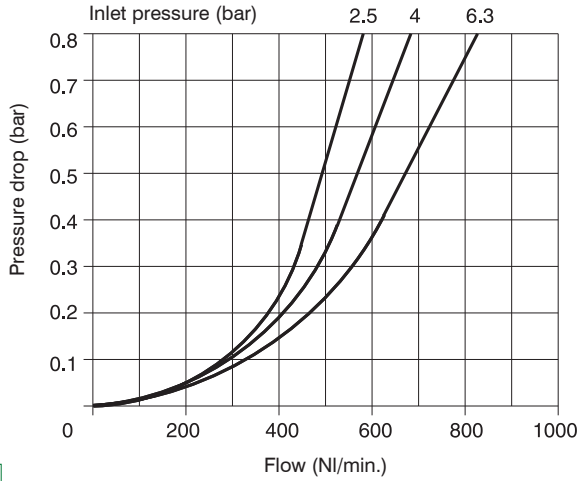

Size 1

Flow rate curves

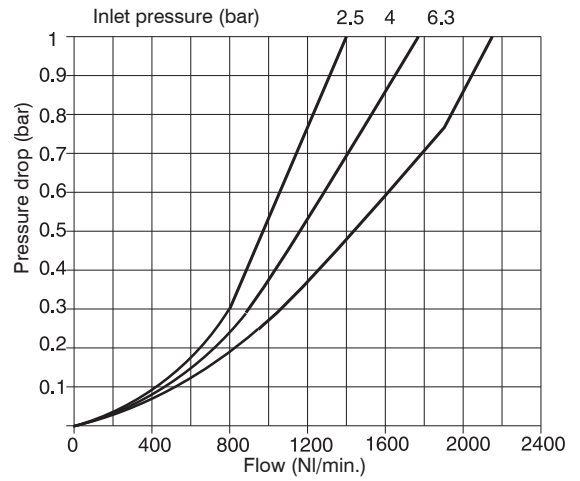

Size 2

Flow rate curves

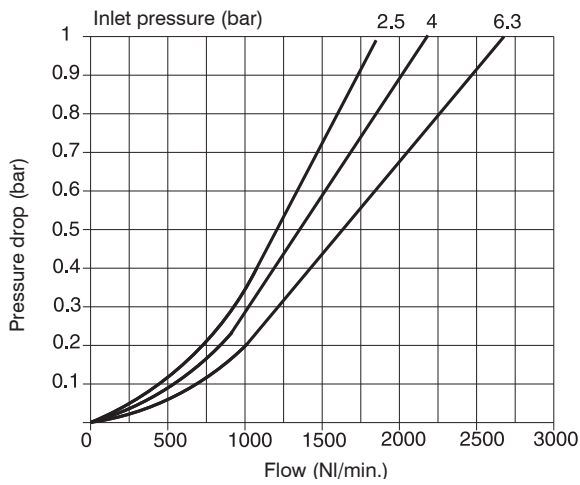

Size 3

Flow rate curves

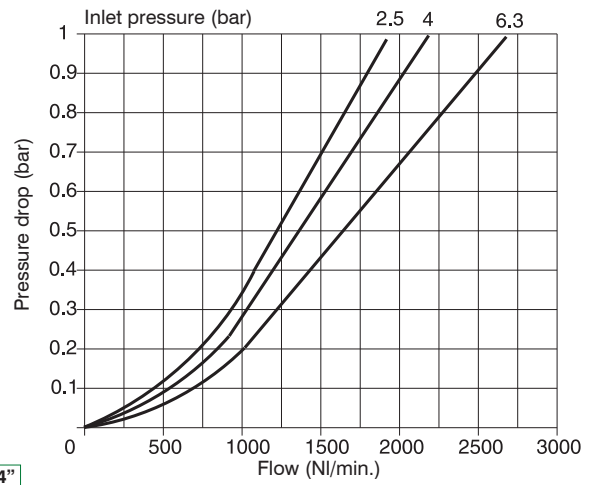

Size 3 3/4"

Flow rate curves

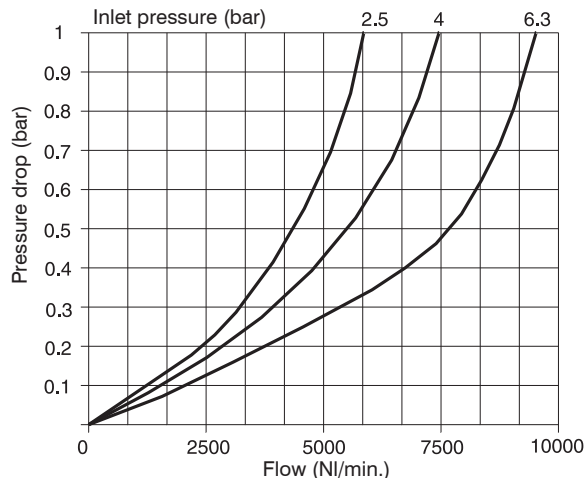

Size 4

2

AIR TREATMENT

**Coalescing filters**

- ▶ Coalescing filter
- ▶ Available in 4 sizes with flow rates up to 3000 NI/min and connections from 1/8" to 1"
- ▶ Filtering cartridge with filtration grade of 0,01 μm
- ▶ Filtering performances 99.97% (particles up to 0.01 μm)
- ▶ Bowls screwed to the body (Size 1)
- ▶ Bowl assembly via bayonet type quick coupling mechanism with safety button (Size 2 - Size 3 - Size 4)
- ▶ Semi-automatic or automatic drain
- ▶ Atex certification (II 2GD o II 3GD) on request

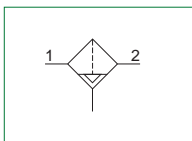
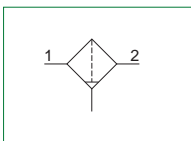
**AIR TREATMENT**

**Note**  
 In order to ensure the high level of filtration, it is recommended that a 5μ filter is installed before the coalescing filter. In order to ensure that any fluid discharged by the auto drain assembly is adequately drained away, it is recommended you use a 6mm fitting and tube.

Technical characteristics	Size			
	Size 1	Size 2	Size 3	Size 4
<b>Body and connections type</b>	Zinc alloy body, Zinc alloy integrated connections Technopolymer body, metal connections	Aluminium body, integrated aluminium connections		
<b>Protection and bowl type</b>	Technopolymer protection - PA bowl (Size 1 available without protection)			Metal bowl with blind metal bowl
<b>IN / OUT connections</b>	G1/8" - G1/4"	G1/4" - G3/8"	G3/8" - G1/2", G3/4"	G1"
<b>Assembly configuration</b>	Stand alone Panel mounted with M4 screws	Stand alone Panel mounted with M5 screws	Stand alone Panel mounted with M6 screws	Stand alone Panel mounted with M8 screws
<b>Assembly position</b>	Vertical ±5°			
<b>Filter pore size (μm)</b>	0,01, efficiency of 99,97%			
<b>Bowl capacity (cm³)</b>	20	30	48	178
<b>Condensation drain</b>	Semi-automatic Automatic			
<b>Max. fittings torque IN / OUT connections</b>	G1/8" metal: 15 G1/4" metal: 20	G1/4" metal: 20 G3/8" metal: 25	G3/8" metal: 25 G1/2" metal: 30 G3/4" metal: 35	G1"metal: 35

Operational characteristics	Size							
	Size 1	Size 2	Size 3	Size 4	Size 1	Size 2	Size 3	Size 4
	Semi-automatic condensation drain				Automatic condensation drain			
<b>Maximum working pressure (bar)</b>	13				10			
<b>Minimum working pressure (bar)</b>	0,5							
<b>Working temperature (°C)</b>	-5 ÷ +50							

Weights	Size			
	Size 1	Size 2	Size 3	Size 4
Zinc alloy body version (g)	225	/	/	/
Technopolymer body version (g)	110	/	/	/
Aluminium body version (g)	/	255	405	1700



Order codes

17 308A . E . S

Size, body and connections
008A : Zinc alloy body, connections G1/8" (only for size 1)
008B : Zinc alloy body, connections G1/4" (only for size 1)
108A : Technopolymer body, connections G1/8" (only for size 1)
108B : Technopolymer body, connections G1/4" (only for size 1)
208A : Aluminium body, connections G1/4" (only for size 2)
208B : Aluminium body, connections G3/8" (only for size 2)
308A : Aluminium body, connections G3/8" (only for size 3)
308B : Aluminium body, connections G1/2" (only for size 3)
308E : Aluminium body, connections G3/4" (only for size 3)
408B : Aluminium body, connections G1" (only for size 4)

Filter efficiency
E : 0,01 µm, efficiency of 99,97%

Type
P : Bowl protection (only for size 1)
S : Automatic drain (for all sizes)
PS : Bowl protection and automatic drain (only for size 1)

**Example: 17308A.E.S**

Size 3 coalescing filter, aluminium body, G3/8" connections, filter efficiency of 99,97%, automatic drain

**Dimensions**

2  
AIR TREATMENT

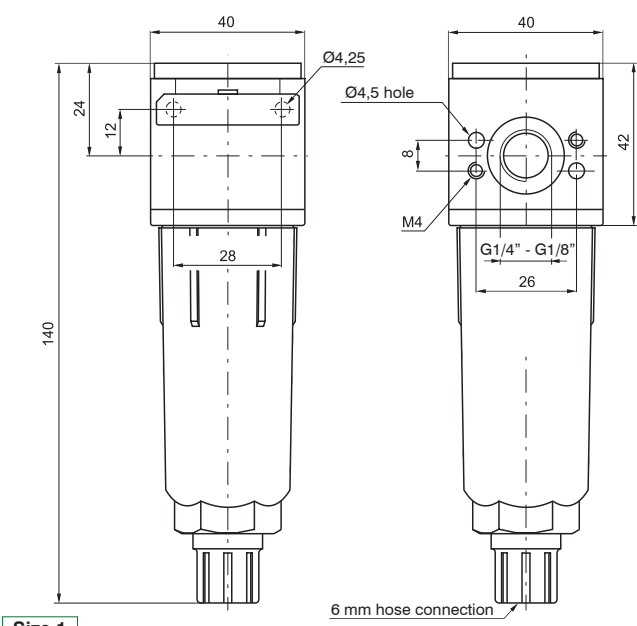

**Size 1**

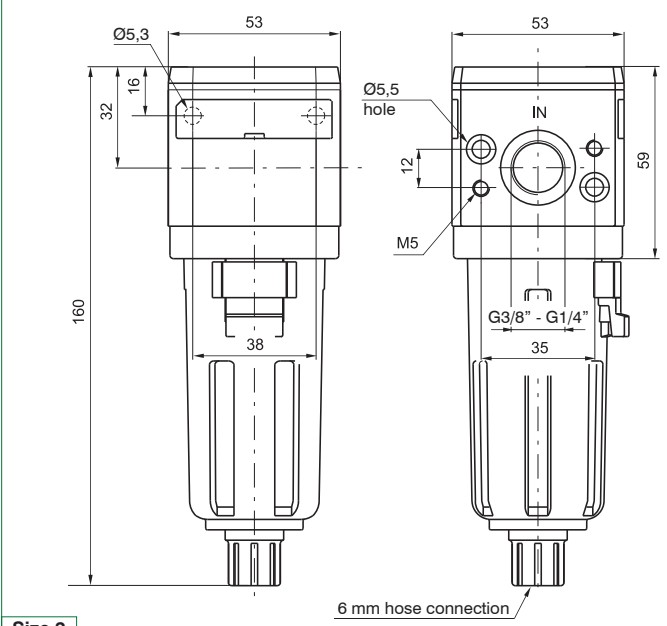

**Size 2**

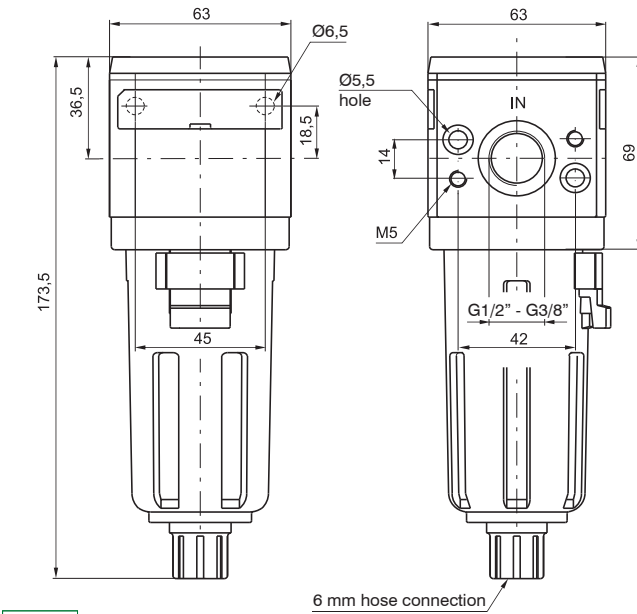

**Size 3**

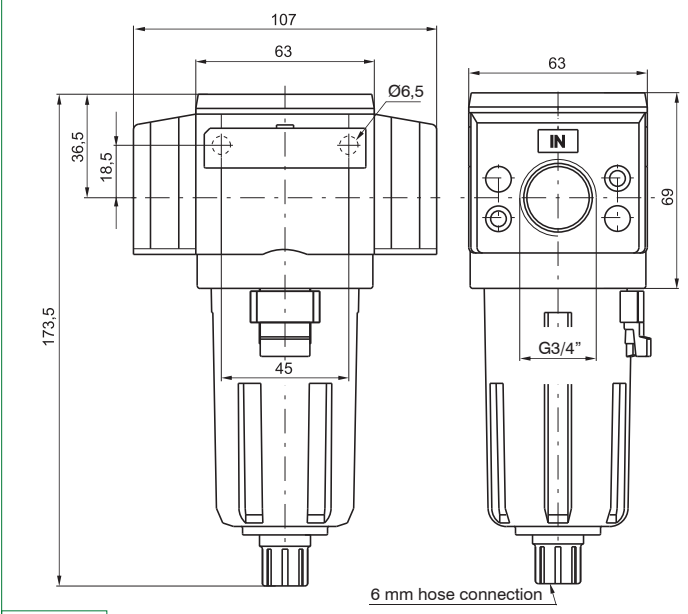

**Size 3 3/4"**

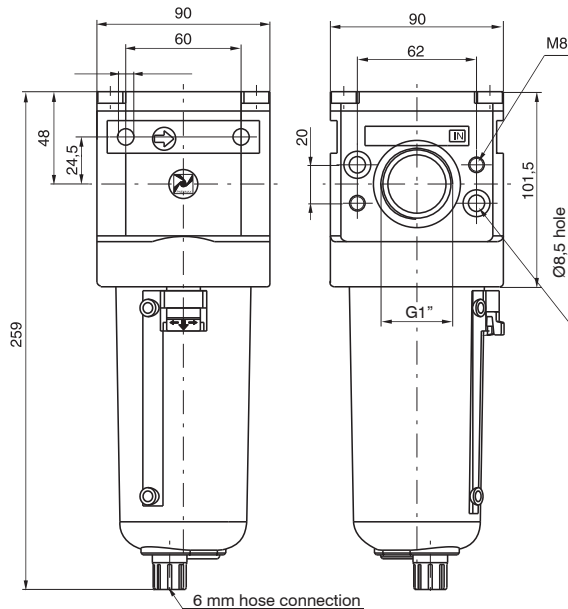

**Size 4**



Characteristic curves

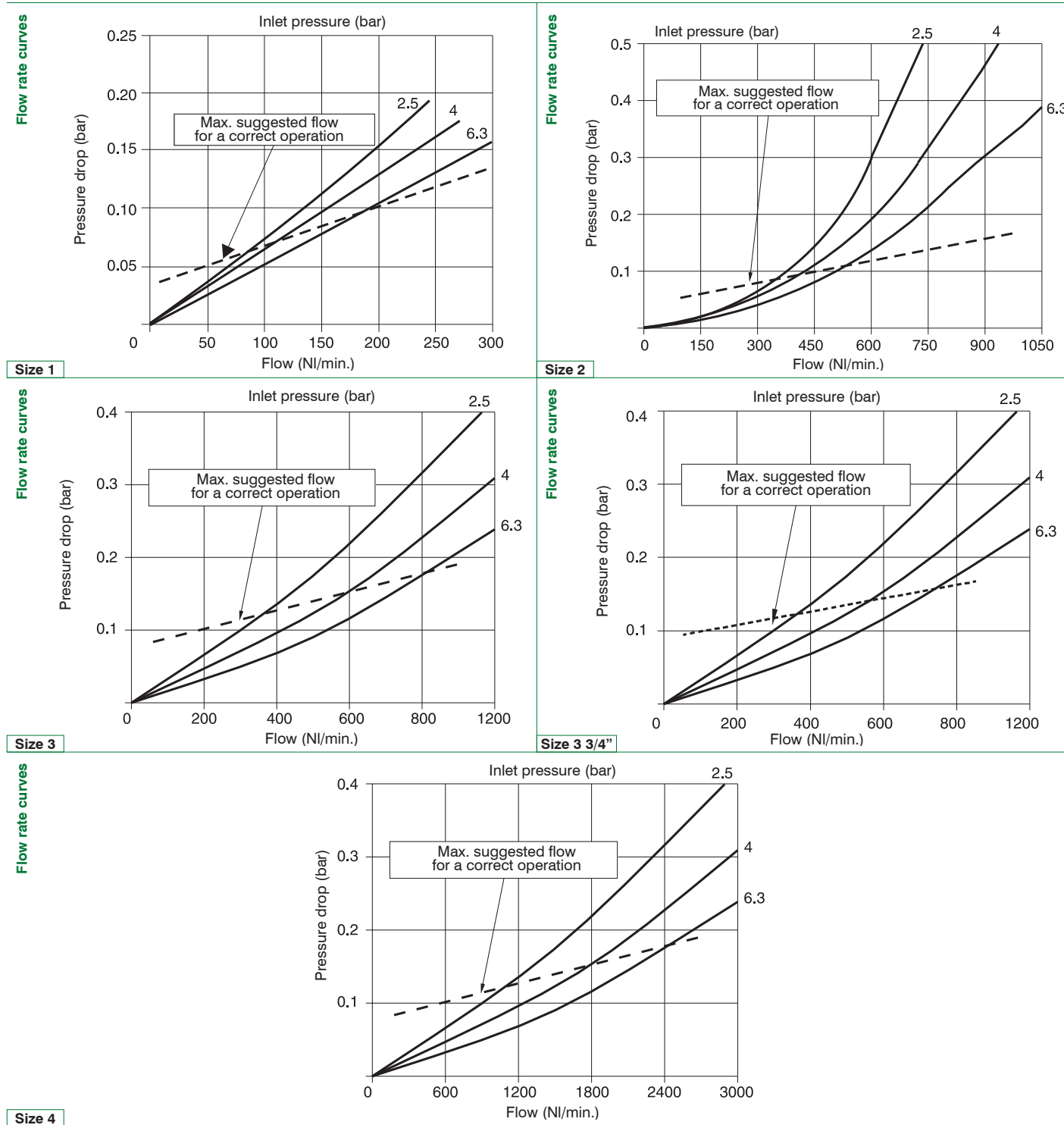

2

AIR TREATMENT

► **Dynamic drier**



- ▶ Aluminium body
- ▶ Wall mounting possibility with M8 screws
- ▶ Filtering cartridge made of HDPE available in three different filtration grades (5µm, 20µm, 50µm)
- ▶ Filter cartridge can be regenerated by washing / blowing it or replaced
- ▶ With blind metal bowl
- ▶ Bowl assembly via bayonet type quick coupling mechanism with safety button
- ▶ Automatic condensation drain

2  
AIR TREATMENT

Technical characteristics	Size
	Size 4
Body and connections type	Aluminium body with integrated aluminium connections
Protection and bowl type	Metal bowl with blind metal bowl
IN / OUT connections	G1"
Assembly configuration	Stand alone Panel mounted with M8 screws
Assembly position	Vertical ±5°
Filter pore size (µm)	5 / 20 / 50
Filter efficiency at flow rate 1500 NI/min	96,00%
Bowl capacity (cm³)	160
Condensation drain	Automatic
Max. fittings torque IN / OUT connections	G1"metal: 35

Operational characteristics	Size
	Size 4
	Automatic condensation drain
Maximum working pressure (bar)	13
Minimum working pressure (bar)	0,5
Nominal flow rate at 6 bar with Δp=1 (NI/min)	2500
Working temperature (°C)	-5 ÷ +50

Weights	Size
	Size 4
Aluminium body version (g)	1700



Order codes

17 40EB . A . S

Size, body and connections

40EB : Aluminium body, connections G1" (only for size 4)

Filter pore size

A : 5 µm

B : 20 µm

C : 50 µm

Example: 1740EB.A.S

Dynamic direr Size 4, aluminium body, G1" connections, filter pore size 5 µm

Dimensions

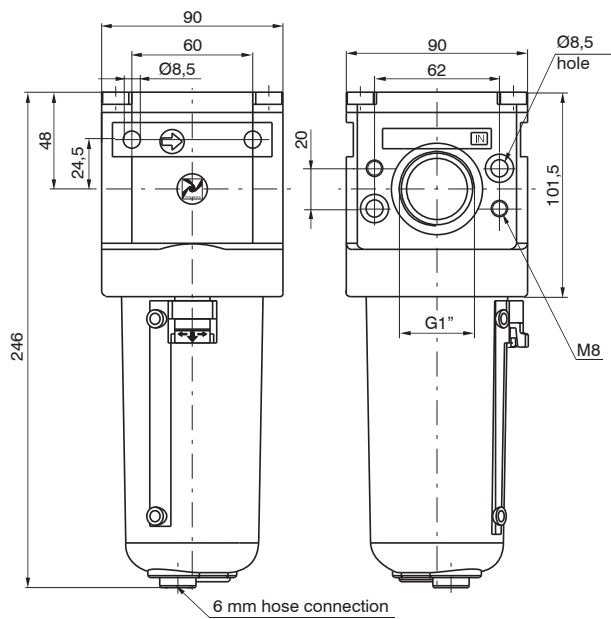

Size 4

**Filter regulators**

- ▶ Filter - diaphragm pressure regulator with relieving
- ▶ Available in 3 sizes with flow rates up to 3500 NI/min and connections from 1/8" to 3/4"
- ▶ Low hysteresis rolling diaphragm and balanced spool
- ▶ Filtering element made of HDPE available in 3 different filtration grades (5µm, 20µm and 50µm)
- ▶ Bowls screwed to the body (Size 1)
- ▶ Bowl assembly via bayonet type quick coupling mechanism with safety button (Size 2 - Size 3)
- ▶ Semi-automatic or automatic drain
- ▶ Available in four pressure ranges up to 12 bar
- ▶ Fitted with panel mounting locking ring
- ▶ Atex certification (II 2GD o II 3GD) on request

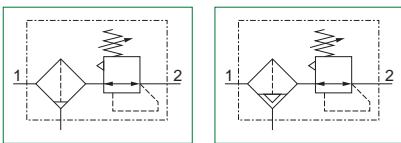
**Note**

For installations where a more accurate and constant pressure is required, the unit should be installed as close as possible to the point of use. In order to ensure that any fluid discharged by the auto drain assembly is adequately drained away, it is recommended you to use a 6mm fitting and tube.

**AIR TREATMENT**
**2**

Technical characteristics	Size		
	Size 1	Size 2	Size 3
<b>Body and connections type</b>	Zinc alloy body, Zinc alloy integrated connections Technopolymer body, metal connections	Aluminium body, integrated aluminium connections	
<b>Protection and bowl type</b>	Technopolymer protection - PA bowl (Size 1 available without protection)		
<b>IN / OUT connections</b>	G1/8" - G1/4"	G1/4" - G3/8"	G3/8" - G1/2", G3/4"
<b>Assembly configuration</b>	Stand alone Panel mounting Panel mounted with M4 screws With fixing bracket	Stand alone Panel mounting Panel mounted with M5 screws With fixing bracket	Stand alone Panel mounting Panel mounted with M6 screws With fixing bracket
<b>Assembly position</b>	Vertical ±5°		
<b>Filter pore size (µm)</b>	5 / 20 / 50		
<b>Pressure range (bar)</b>	0 - 2 / 0 - 4 / 0 - 8 / 0 - 12		
<b>Bowl capacity (cm³)</b>	20	30	48
<b>Condensation drain</b>	Semi-automatic Automatic		
<b>Regulation</b>	Manual push and lock with pressure Manual lockable with accessories		
<b>Pressure measurement</b>	G1/8" Pressure gauge connection port		
<b>Max. fittings torque IN / OUT connections</b>	G1/8" metal: 15 G1/4" metal: 20	G1/4" metal: 20 G3/8" metal: 25	G3/8" metal: 25 G1/2" metal: 30 G3/4" metal: 35

Operational characteristics	Size					
	Size 1	Size 2	Size 3	Size 1	Size 2	Size 3
	Semi-automatic condensation drain			Automatic condensation drain		
<b>Maximum working pressure (bar)</b>	13			10		
<b>Minimum working pressure (bar)</b>	0,5					
<b>Working temperature (°C)</b>	-5 ÷ +50					

Weights	Size		
	Size 1	Size 2	Size 3
Zinc alloy body version (g)	295	/	/
Technopolymer body version (g)	180	/	/
Aluminium body version (g)	/	450	645



Order codes

17 304A . B . D . S . K

**Size, body and connections**

<b>004A</b> : Zinc alloy body, connections G1/8" (only for size 1)
<b>004B</b> : Zinc alloy body, connections G1/4" (only for size 1)
<b>104A</b> : Technopolymer body, connections G1/8" (only for size 1)
<b>104B</b> : Technopolymer body, connections G1/4" (only for size 1)
<b>204A</b> : Aluminium body, connections G1/4" (only for size 2)
<b>204B</b> : Aluminium body, connections G3/8" (only for size 2)
<b>304A</b> : Aluminium body, connections G3/8" (only for size 3)
<b>304B</b> : Aluminium body, connections G1/2" (only for size 3)
<b>304E</b> : Aluminium body, connections G3/4" (only for size 3)

**Filter pore size**

<b>A</b> : 5 µm
<b>B</b> : 20 µm
<b>C</b> : 50 µm

**Pressure range**

<b>A</b> : 0 - 2 bar
<b>B</b> : 0 - 4 bar
<b>C</b> : 0 - 8 bar
<b>D</b> : 0 - 12 bar

**Type**

<b>P</b> : Bowl protection (only for size 1)
<b>S</b> : Automatic drain (for all sizes)
<b>PS</b> : Bowl protection and automatic drain (only for size 1)

**Options**

: Standard
<b>K</b> : Lockable version
<b>U</b> : Lockable version with universal key

**Example: 17304A.B.D.S.K**

Filter regulator size 3, aluminium body, G3/8" connections, filter pore size 20 µm 0 - 12 bar, automatic drain lockable version

**Dimensions**

2

AIR TREATMENT

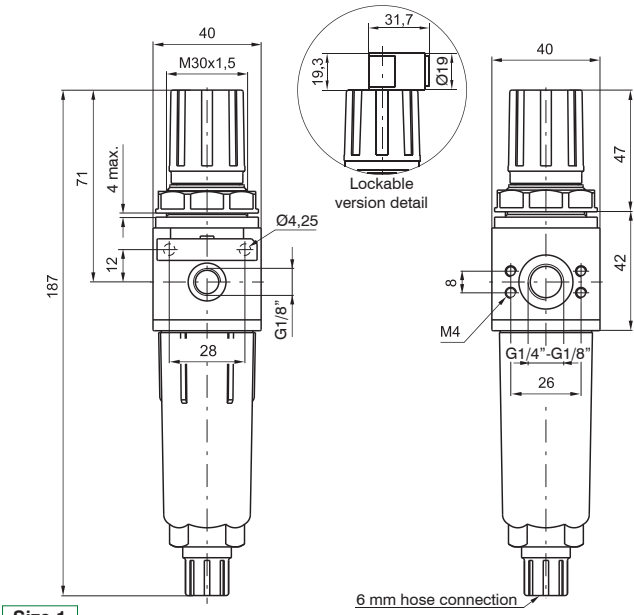

**Size 1**

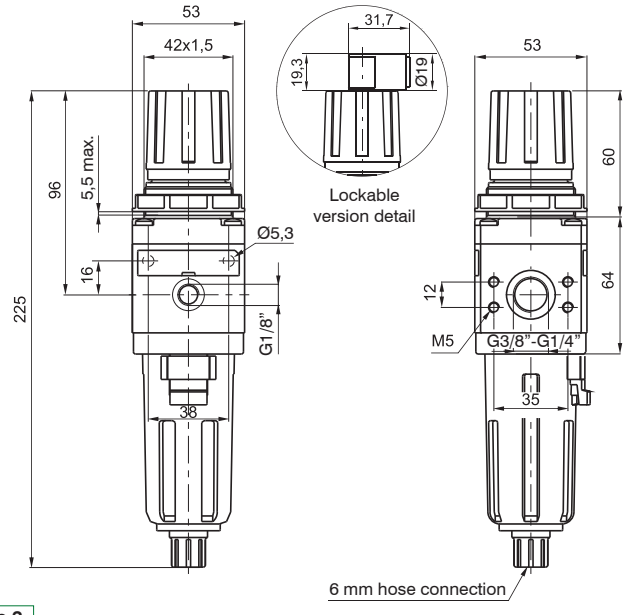

**Size 2**

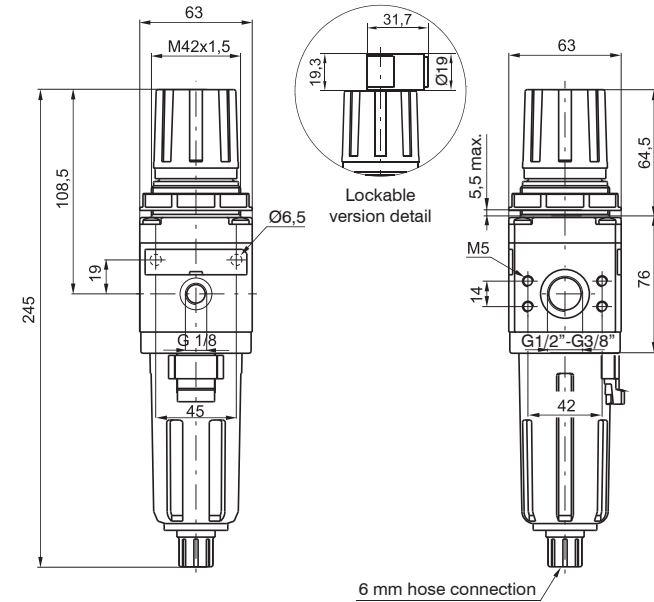

**Size 3**

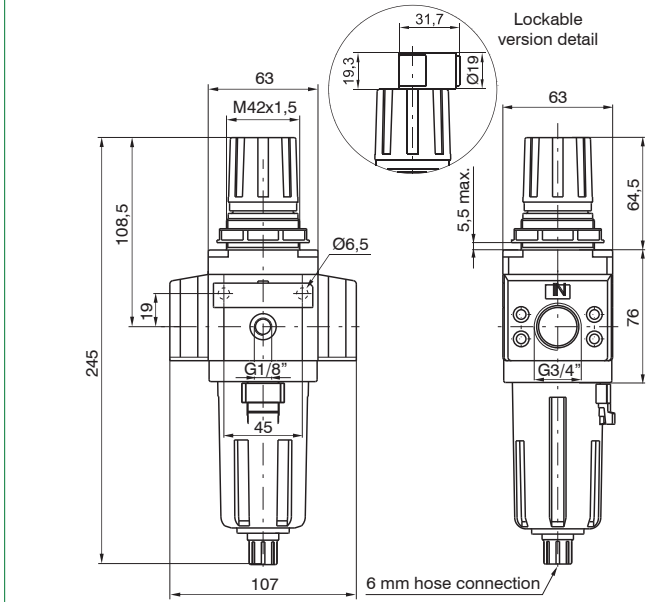

**Size 3 3/4"**



Characteristic curves

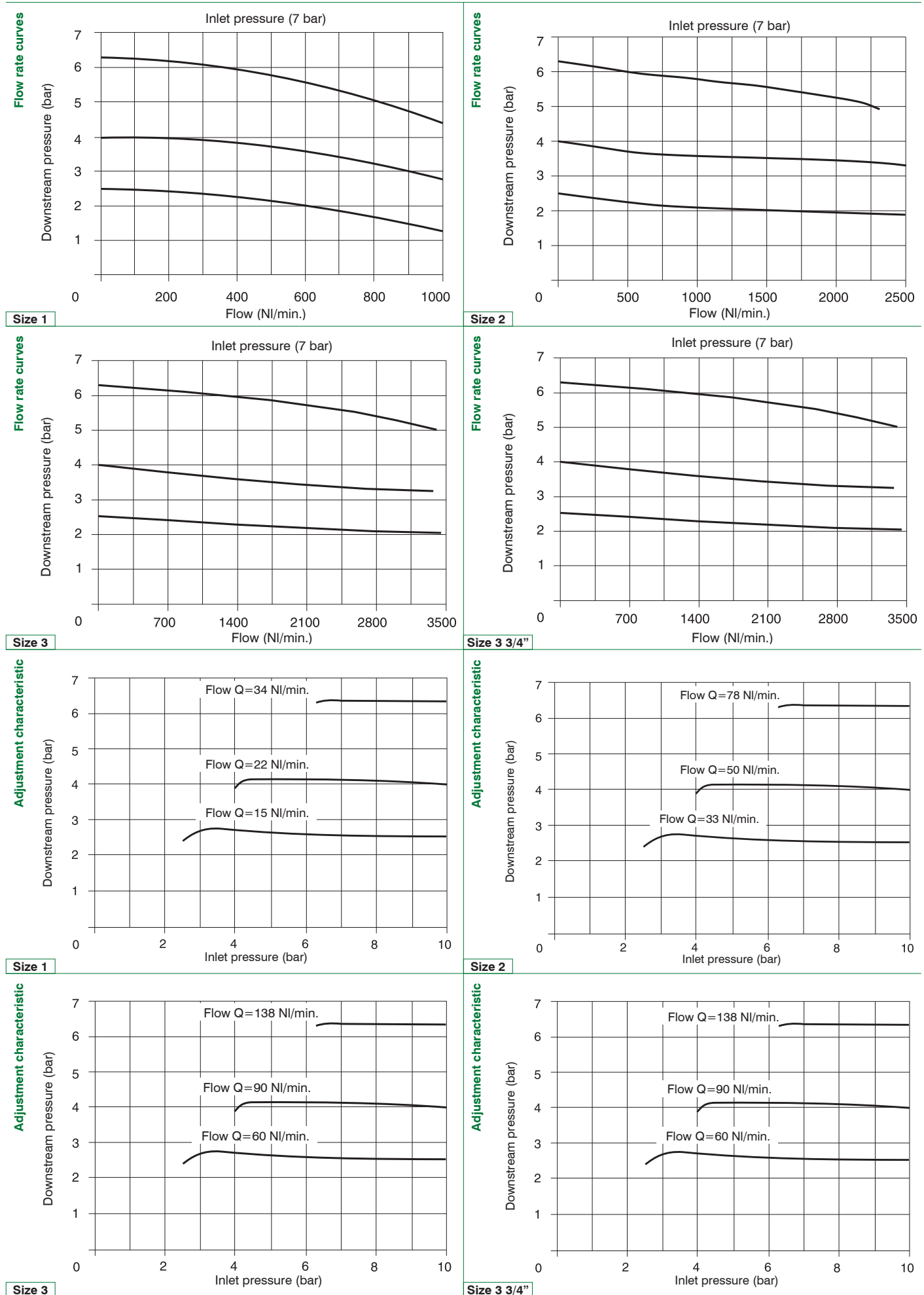

2

AIR TREATMENT

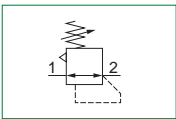

- ▶ Diaphragm pressure regulator with relieving
- ▶ Available in 4 sizes with flow rates up to 8000 NI/min and connections from 1/8" to 1"
- ▶ Low hysteresis rolling diaphragm and balanced spool
- ▶ Available in four pressure ranges up to 12 bar
- ▶ Fitted with panel mounting locking ring
- ▶ High flow rate of the discharge valve for the downstream overpressure (Size 4)
- ▶ Atex certification (II 2GD o II 3GD) on request

**2**
**AIR TREATMENT**

**Note**  
 For installations where a more accurate and constant pressure is required, the unit should be installed as close as possible to the point of use.

Technical characteristics	Size			
	Size 1	Size 2	Size 3	Size 4
<b>Body and connections type</b>	Zinc alloy body, Zinc alloy integrated connections Technopolymer body, metal connections	Aluminium body, integrated aluminium connections		
<b>IN / OUT connections</b>	G1/8" - G1/4"	G1/4" - G3/8"	G3/8" - G1/2", G3/4"	G1"
<b>Assembly configuration</b>	Stand alone Panel mounting Panel mounted with M4 screws With fixing bracket	Stand alone Panel mounting Panel mounted with M5 screws With fixing bracket	Stand alone Panel mounting Panel mounted with M6 screws With fixing bracket	Stand alone Panel mounting Panel mounted with M8 screws
<b>Assembly position</b>	Indifferent			
<b>Pressure range (bar)</b>	0 - 2 / 0 - 4 / 0 - 8 / 0 - 12			
<b>Regulation</b>	Manual push and lock with pressure Manual lockable with accessories			
<b>Pressure measurement</b>	G1/8" Pressure gauge connection port			
<b>Max. fittings torque IN / OUT connections</b>	G1/8" metal: 15 G1/4" metal: 20	G1/4" metal: 20 G3/8" metal: 25	G3/8" metal: 25 G1/2" metal: 30 G3/4" metal: 35	G1" metal: 35

Operational characteristics	Size			
	Size 1	Size 2	Size 3	Size 4
<b>Maximum working pressure (bar)</b>	13			
<b>Minimum working pressure (bar)</b>	0,5			
<b>Working temperature (°C)</b>	-5 ÷ +50			

Weights	Size			
	Size 1	Size 2	Size 3	Size 4
Zinc alloy body version (g)	250	/	/	/
Technopolymer body version (g)	135	/	/	/
Aluminium body version (g)	/	390	550	1900



Order codes

17 302A . D . L . K

Size, body and connections
002A : Zinc alloy body, connections G1/8" (only for size 1)
002B : Zinc alloy body, connections G1/4" (only for size 1)
102A : Technopolymer body, connections G1/8" (only for size 1)
102B : Technopolymer body, connections G1/4" (only for size 1)
202A : Aluminium body, connections G1/4" (only for size 2)
202B : Aluminium body, connections G3/8" (only for size 2)
302A : Aluminium body, connections G3/8" (only for size 3)
302B : Aluminium body, connections G1/2" (only for size 3)
302E : Aluminium body, connections G3/4" (only for size 3)
402NB : Aluminium body, connections G1" (only for size 4)

Pressure range
A : 0 - 2 bar
B : 0 - 4 bar
C : 0 - 8 bar
D : 0 - 12 bar

Type
L : Without relieving
SM : Improved relieving (not available for Size 4)

Options
: Standard
K : Lockable version
U : Lockable version with universal key

**Example: 17302A.D.L.K**

Regulator size 3, body in light aluminium alloy, G3/8"connections, 0 - 12 bar, without relieving, lockable version

**Dimensions**

2  
AIR TREATMENT

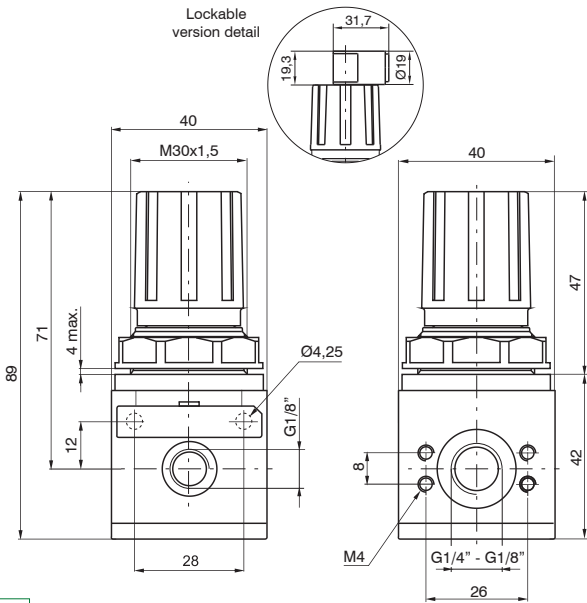

**Size 1**

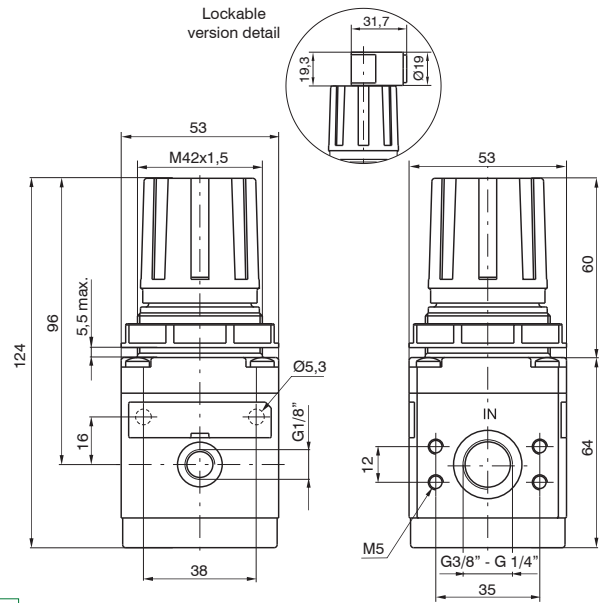

**Size 2**

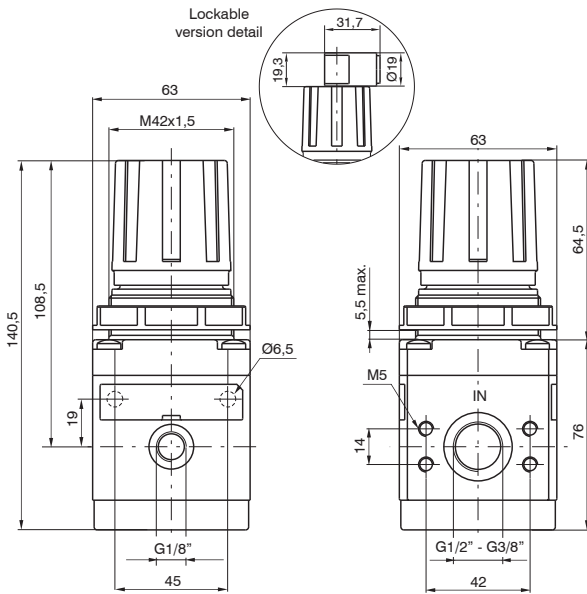

**Size 3**

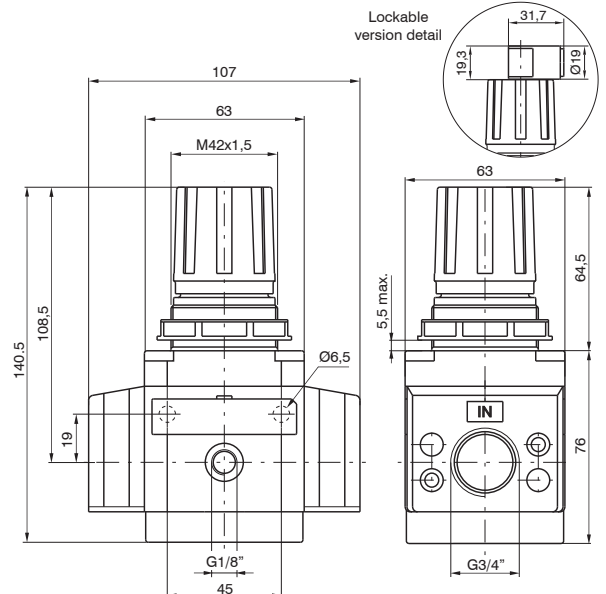

**Size 3 3/4"**

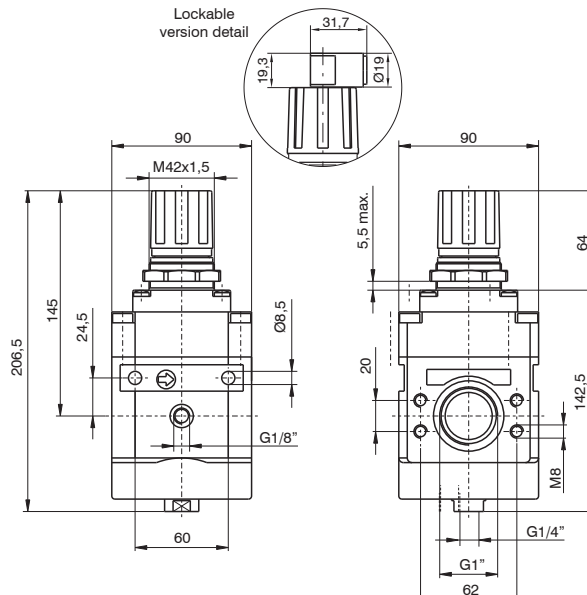

**Size 4**





Characteristic curves

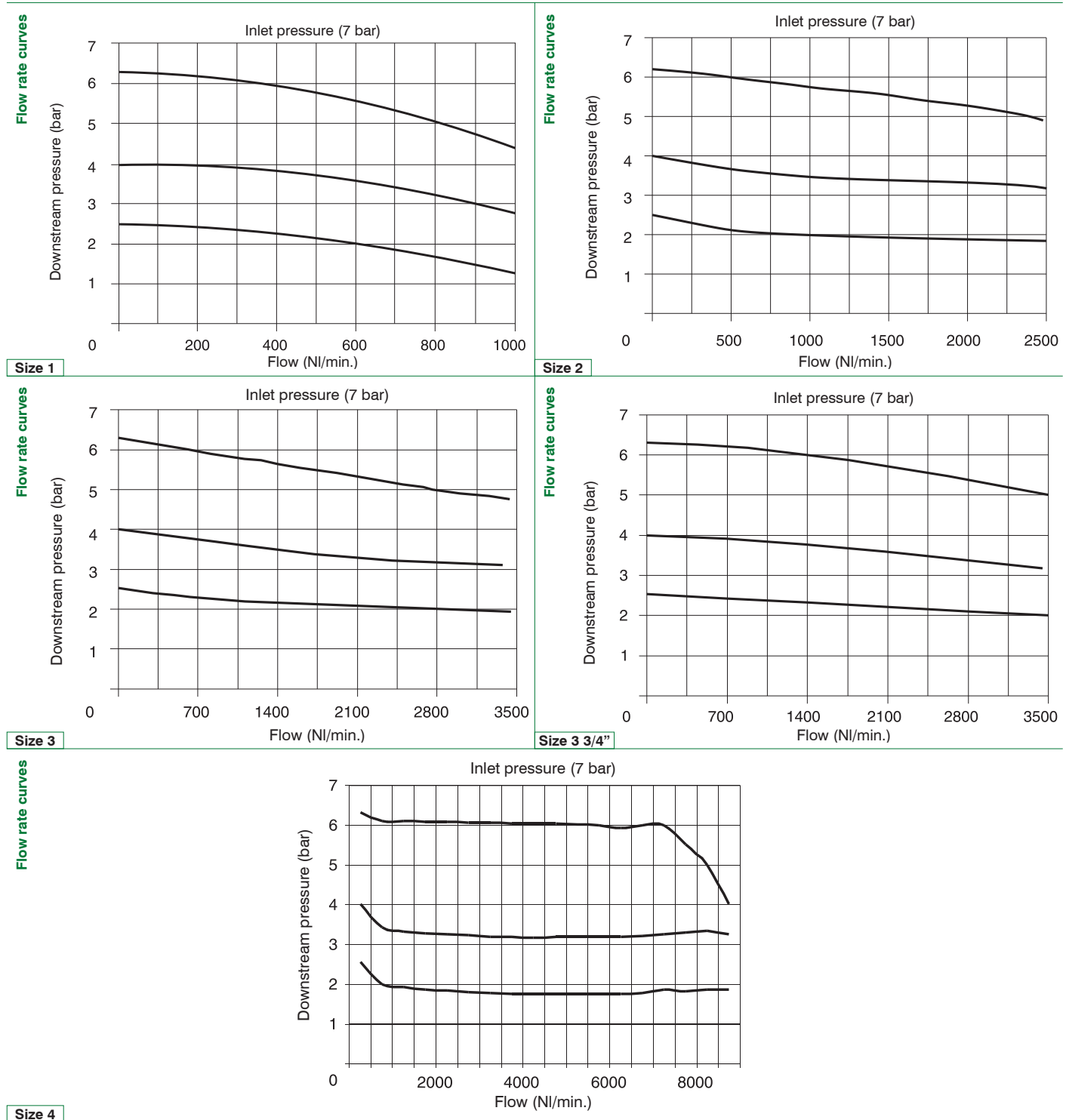

2

AIR TREATMENT



Adjustment characteristic

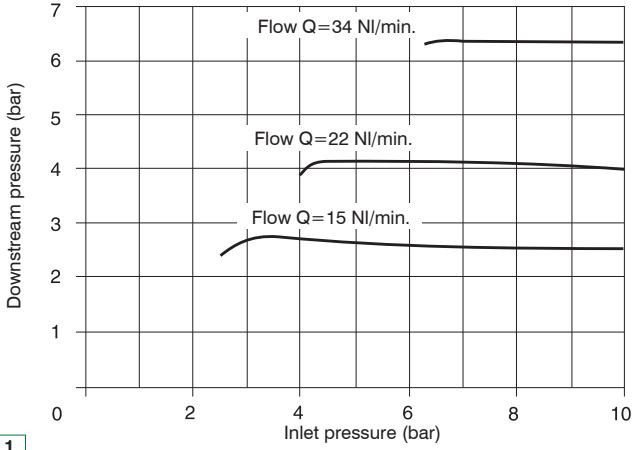

Size 1

Adjustment characteristic

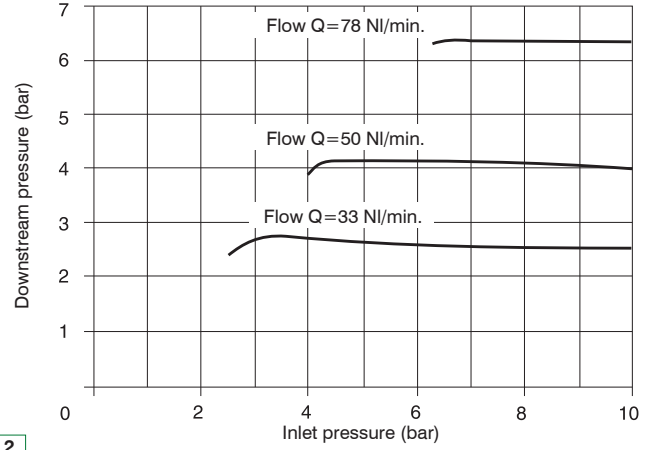

Size 2

Adjustment characteristic

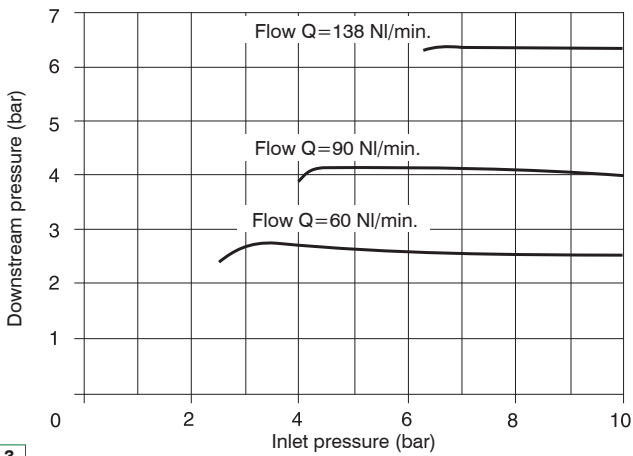

Size 3

Adjustment characteristic

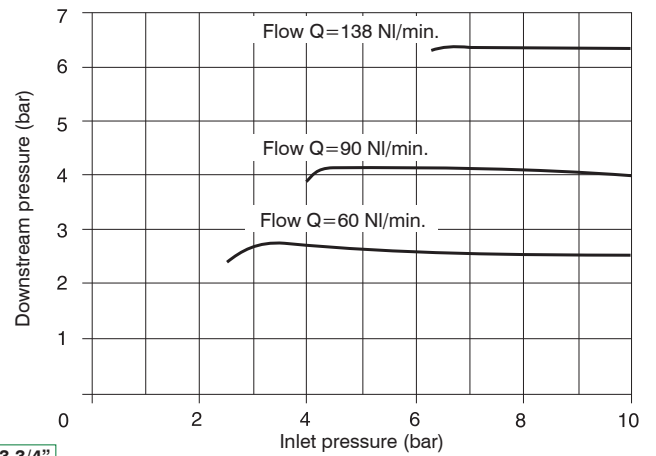

Size 3 3/4"

Adjustment characteristic

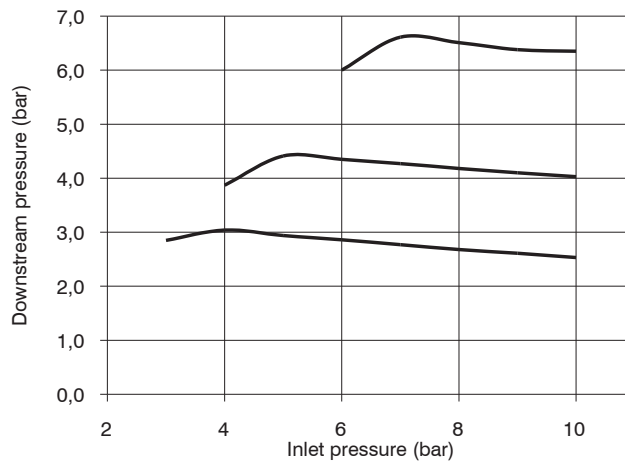

Size 4



▶ Regulators with integrated pressure gauge



- ▶ Diaphragm pressure regulator with relieving
- ▶ Available in 4 sizes with flow rates up to 3500 NI/min and connections from 1/8" to 1/2"
- ▶ Low hysteresis rolling diaphragm and balanced spool
- ▶ Available in four pressure ranges up to 12 bar
- ▶ Fitted with panel mounting locking ring
- ▶ Pressure gauge included on the top of adjusting knob
- ▶ Atex certification (II 2GD o II 3GD) on request

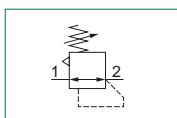

**Note**

For installations where a more accurate and constant pressure is required, the unit should be installed as close as possible to the point of use.

Technical characteristics	Size		
	Size 1	Size 2	Size 3
<b>Body and connections type</b>	Zinc alloy body, Zinc alloy integrated connections Technopolymer body, metal connections	Aluminium body, integrated aluminium connections	
<b>IN / OUT connections</b>	G1/8" - G1/4"	G1/4" - G3/8"	G3/8" - G1/2"
<b>Assembly configuration</b>	Stand alone Panel mounting Panel mounted with M4 screws With fixing bracket	Stand alone Panel mounting Panel mounted with M5 screws With fixing bracket	Stand alone Panel mounting Panel mounted with M6 screws With fixing bracket
<b>Assembly position</b>	Indifferent		
<b>Pressure range (bar)</b>	0 - 2 / 0 - 4 / 0 - 8 / 0 - 12		
<b>Regulation</b>	Manual push and lock with pressure		
<b>Pressure measurement</b>	G1/8" Pressure gauge connection port is included on the top of adjusting knob		
<b>Max. fittings torque IN / OUT connections</b>	G1/8" metal: 15 G1/4" metal: 20	G1/4" metal: 20 G3/8" metal: 25	G3/8" metal: 25 G1/2" metal: 30

Operational characteristics	Size		
	Size 1	Size 2	Size 3
<b>Maximum working pressure (bar)</b>	13		
<b>Minimum working pressure (bar)</b>	0,5		
<b>Working temperature (°C)</b>	-5 ÷ +50		

Weights	Size		
	Size 1	Size 2	Size 3
Zinc alloy body version (g)	380	/	/
Technopolymer body version (g)	250	/	/
Aluminium body version (g)	/	440	600

**Order codes**

17 **322A** . **D**

**Size, body and connections**

<b>022A</b> : Zinc alloy body, connections G1/8" (only for size 1)
<b>022B</b> : Zinc alloy body, connections G1/4" (only for size 1)
<b>122A</b> : Technopolymer body, connections G1/8" (only for size 1)
<b>122B</b> : Technopolymer body, connections G1/4" (only for size 1)
<b>222A</b> : Aluminium body, connections G1/4" (only for size 2)
<b>222B</b> : Aluminium body, connections G3/8" (only for size 2)
<b>322A</b> : Aluminium body, connections G3/8" (only for size 3)
<b>322B</b> : Aluminium body, connections G1/2" (only for size 3)

**Pressure range**

<b>A</b> : 0 - 2 bar
<b>B</b> : 0 - 4 bar
<b>C</b> : 0 - 8 bar
<b>D</b> : 0 - 12 bar

**Example: 17322A.D**

Size 3 regulator with integrated pressure gauge, Aluminium body, G3/8" connections, 0 - 12 bar

**Dimensions**

AIR TREATMENT

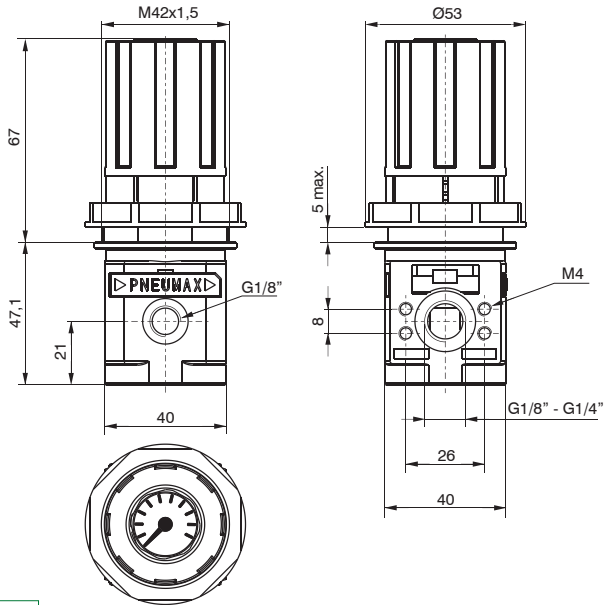

**Size 1**

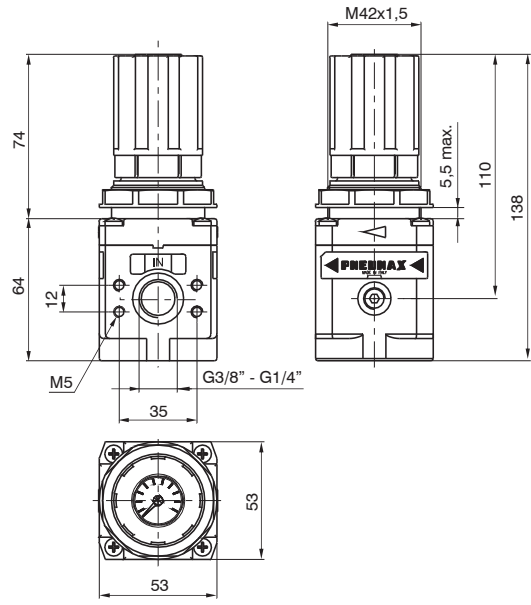

**Size 2**

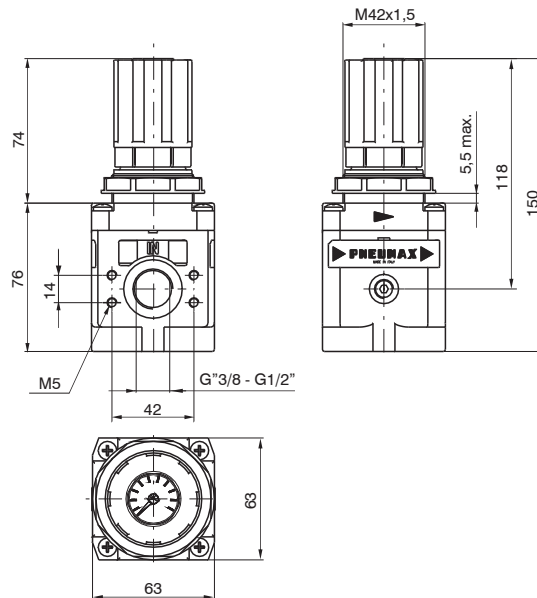

**Size 3**



Characteristic curves

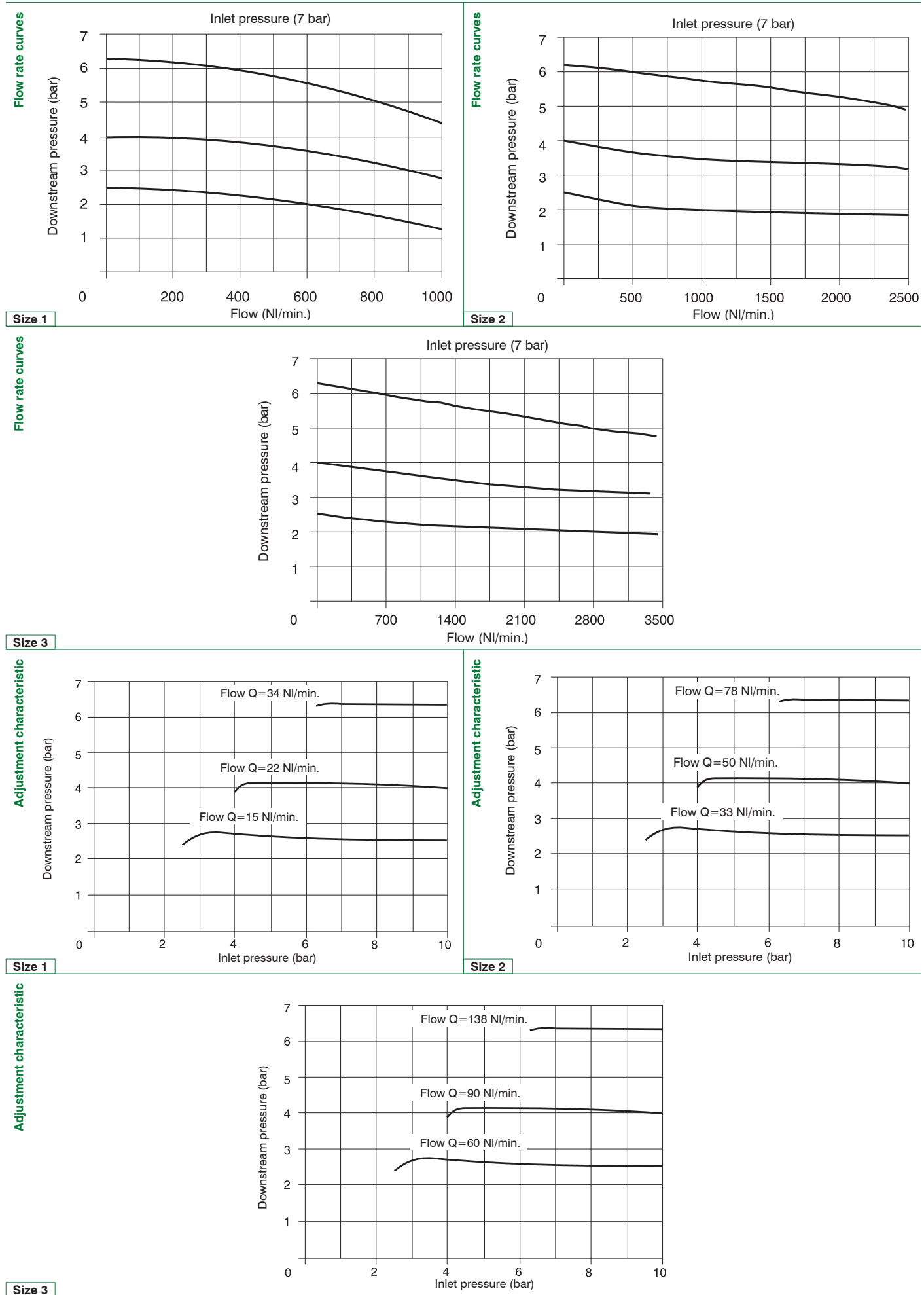

2

AIR TREATMENT



▶ **High sensitive air pressure regulators with high flow rate relieving**



- ▶ Accurate capacity to maintain set pressure
- ▶ Sensitivity combined with high relieving rates
- ▶ High flow rate with extremely low pressure drop
- ▶ Pressure adjusting lockable handle by simply pressing it downwards in the desired position
- ▶ Aluminium body
- ▶ Ring nut for panel mounting
- ▶ Construction with controlled relief
- ▶ Atex certification (II 2GD) on request

2  
AIR TREATMENT

Technical characteristics	Size	
	Size 1	Size 3
Body and connections type	Aluminium body, integrated aluminium connections	
IN / OUT connections	G1/4"	G1/2"
Assembly configuration	Stand alone Panel mounting With fixing bracket	Stand alone Panel mounting With fixing bracket
Assembly position	Indifferent	
Fluid	20µ filtered air and preferably non lubricated	
Air flow with inlet pressure 10 bar (NI/min)	5	
Pressure range (bar)	0,1 - 2 / 0,1 - 4 / 0,1 - 7 / 0,1 - 10	
Regulation	Manual push and lock with pressure Manual lockable with accessories	
Pressure measurement	G1/8" Pressure gauge connection port	
Max. fittings torque IN / OUT connections	G1/4" metal: 20	G1/2" metal: 30

Operational characteristics	Size	
	Size 1	Size 3
Maximum working pressure (bar)	10	
Minimum working pressure (bar)	0,5	
Working temperature (°C)	-5 ÷ +50	

Weights	Size	
	Size 1	Size 3
Aluminium body version (g)	380	970

Order codes

17 3S2B . 0010 . E . K

<b>Size, body and connections</b>
1S2B : Aluminium body, connections G1/4" (only for size 1)
3S2B : Aluminium body, connections G1/2" (only for size 3)
<b>Pressure range</b>
0002 : 0,1 - 2 bar
0004 : 0,1 - 4 bar
0007 : 0,1 - 7 bar
0010 : 0,1 - 10 bar
<b>Type</b>
: Standard
E : External pressure feedback
<b>Options</b>
: Standard
K : Lockable version
U : Lockable version with universal key

**Example: 173S2B.0010.E.K**

Size 3 high sensitive air pressure regulator with high flow rate relieving, aluminium body, G1/2" connections, 0,1 - 10 bar, external pressure feedback, lockable version

Dimensions

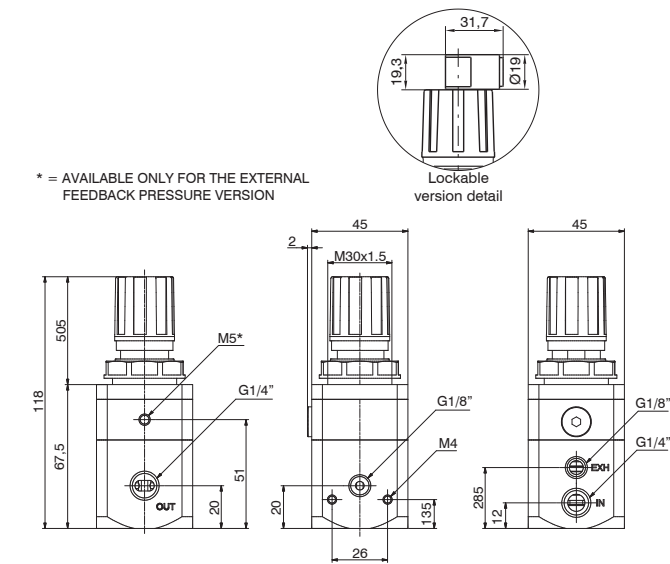

Size 1

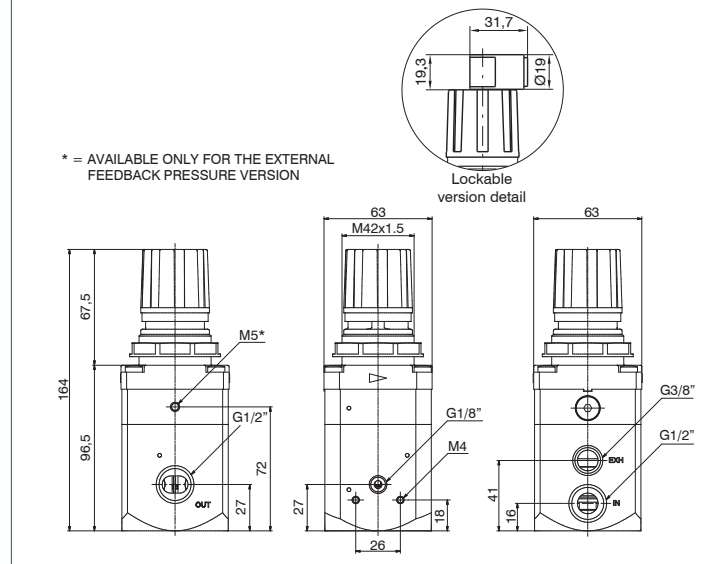

Size 3



**Characteristic curves**

2

AIR TREATMENT

Flow rate curves

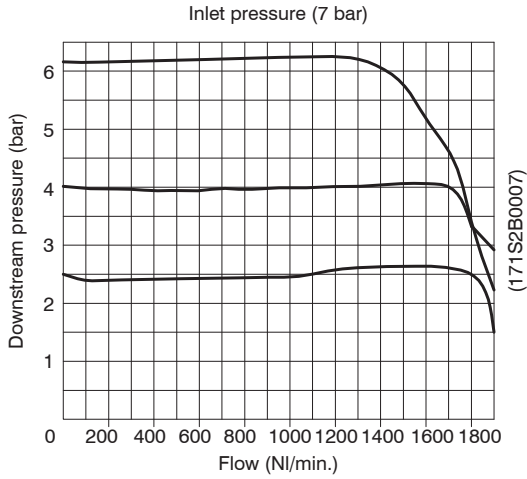

Size 1

Flow rate curves

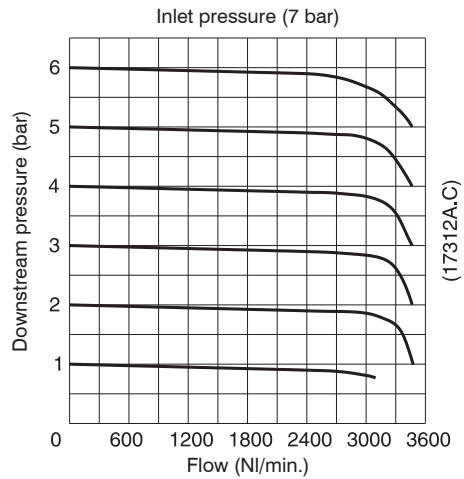

Size 3

Adjustment characteristic

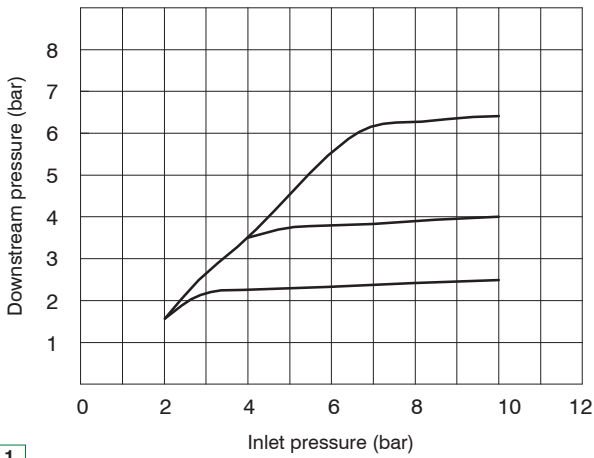

Size 1

Adjustment characteristic

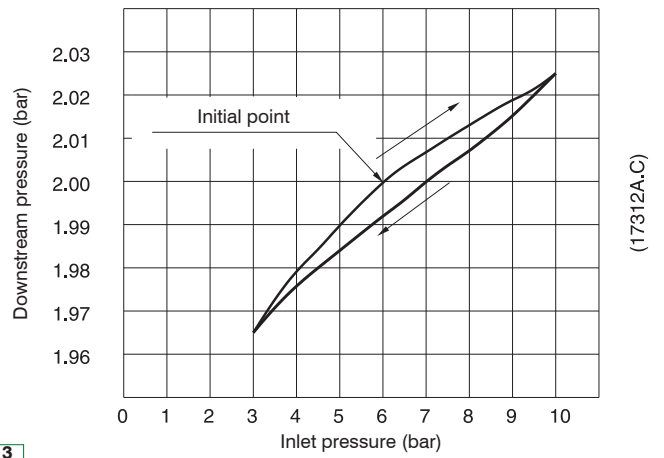

Size 3

Exhaust flow rate curves

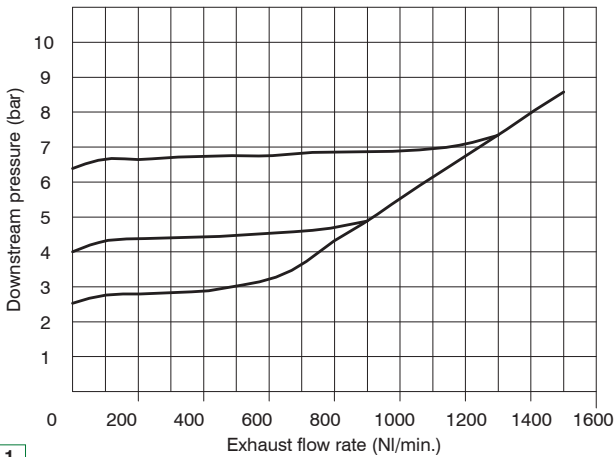

Size 1

Exhaust flow rate curves

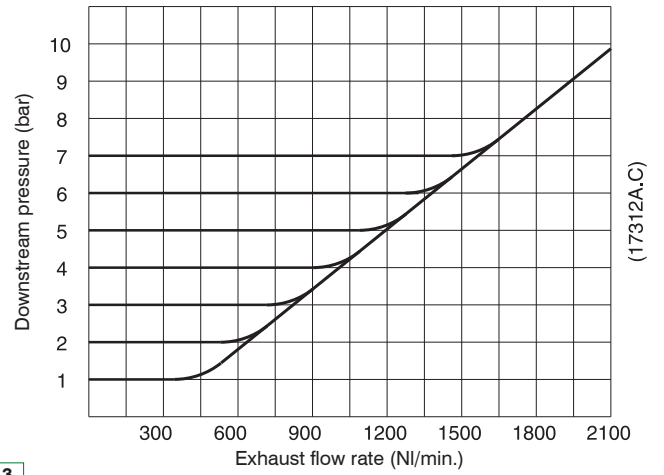

Size 3



► Piloted pressure regulators



- Diaphragm piloted pressure regulator
- Available in 3 sizes with flow rates up to 3500 NI/min and connections from 1/4" a 1"
- Atex certification (II 2GD o II 3GD) on request

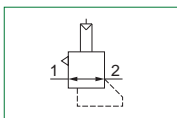

**Note**  
Always regulate the rising pressure.

Technical characteristics	Size		
	Size 2	Size 3	Size 4
Body and connections type	Aluminium body, integrated aluminium connections		
IN / OUT connections	G1/4" - G3/8"	G3/8" - G1/2"	G1"
Assembly configuration	Stand alone Panel mounted with M5 screws	Stand alone Panel mounted with M5 screws	Stand alone Panel mounted with M8 screws
Assembly position	Indifferent		
Pressure range (bar)	0,5 ÷ 10		
Regulation	Pneumatic piloting		
Pressure measurement	G1/8" Pressure gauge connection port		
Max. fittings torque IN / OUT connections	G1/4" metal: 20 G3/8" metal: 25	G3/8" metal: 25 G1/2" metal: 30	G1" metal: 35

Operational characteristics	Size		
	Size 2	Size 3	Size 4
Maximum working pressure (bar)	13		
Minimum working pressure (bar)	0,5		
Pilot pressure range (bar)	0,5 ÷ 10		
Working temperature (°C)	-5 ÷ +50		

Weights	Size		
	Size 2	Size 3	Size 4
Aluminium body version (g)	313	510	1638

2  
AIR TREATMENT

**Order codes**

17 302A . P . L

**Size, body and connections**

**202A** : Aluminium body, connections G1/4" (only for size 2)

**202B** : Aluminium body, connections G3/8" (only for size 2)

**302A** : Aluminium body, connections G3/8" (only for size 3)

**302B** : Aluminium body, connections G1/2" (only for size 3)

**402NB** : Aluminium body, connections G1" (only for size 4)

**Options**

: Standard

L : Without relieving (not available for Size 4)

**Example: 17302A.PL**

Size 3 piloted pressure regulator, aluminium body, G3/8" connections, without relieving

**AIR TREATMENT**

**2** **Dimensions**

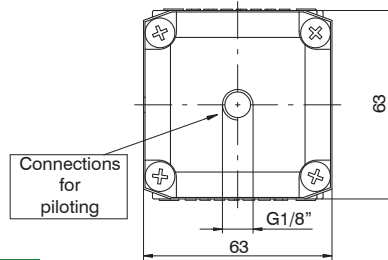
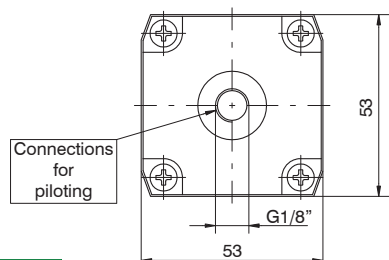
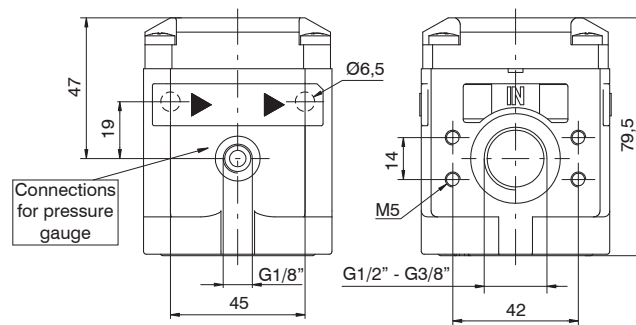
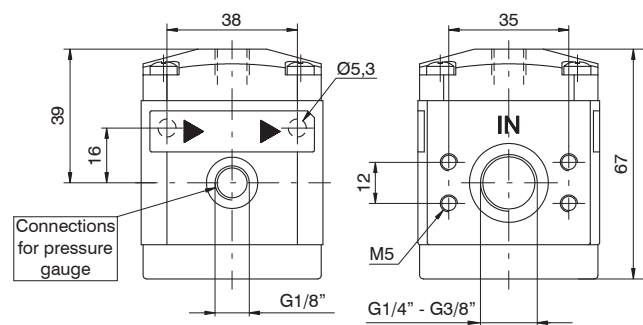

**Size 2**

**Size 3**

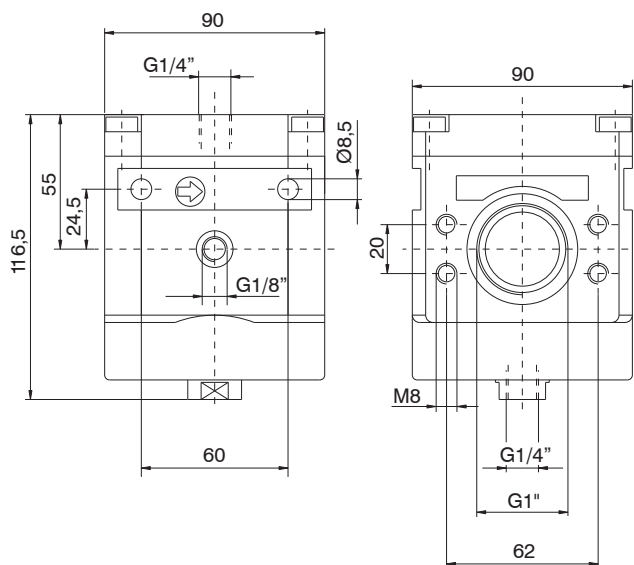

**Size 4**



Characteristic curves

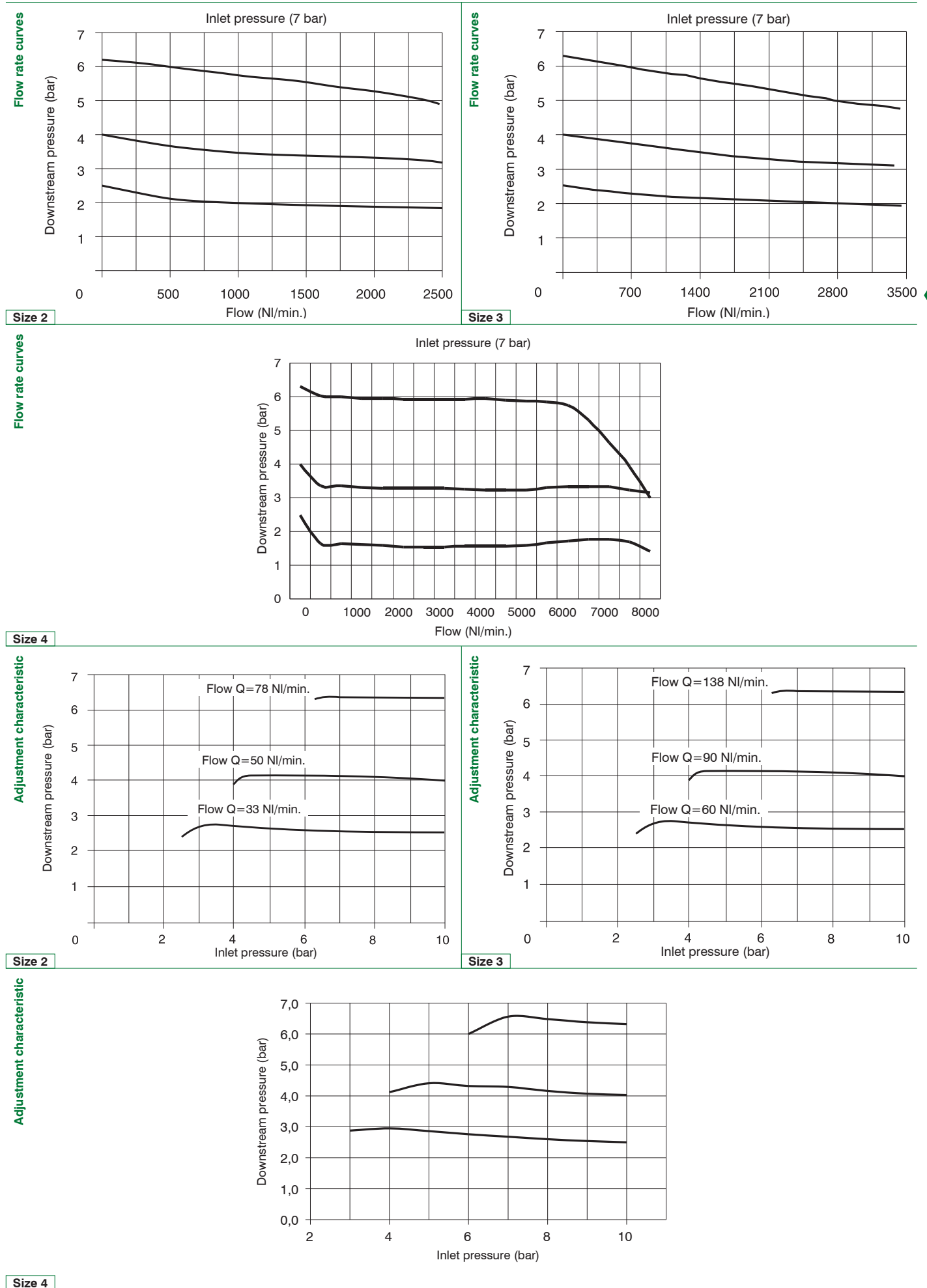

2

AIR TREATMENT



Curve di pilotaggio

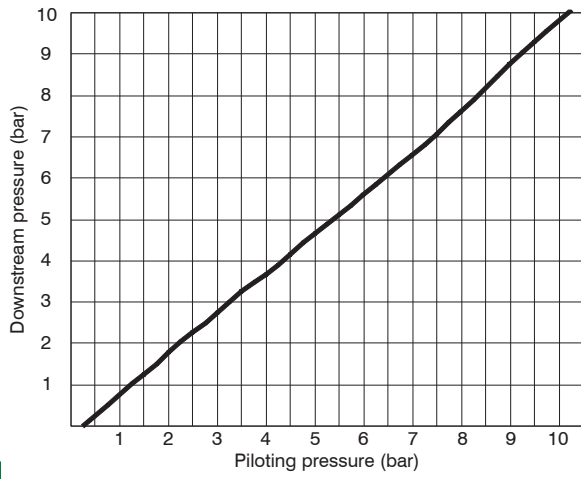

Size 2

Curve di pilotaggio

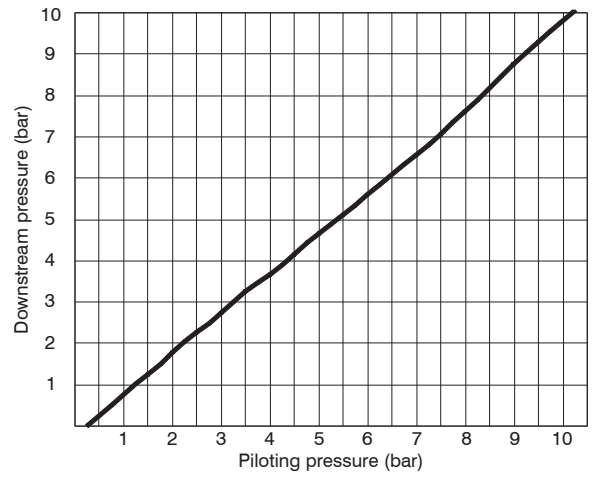

Size 3

Curve di pilotaggio

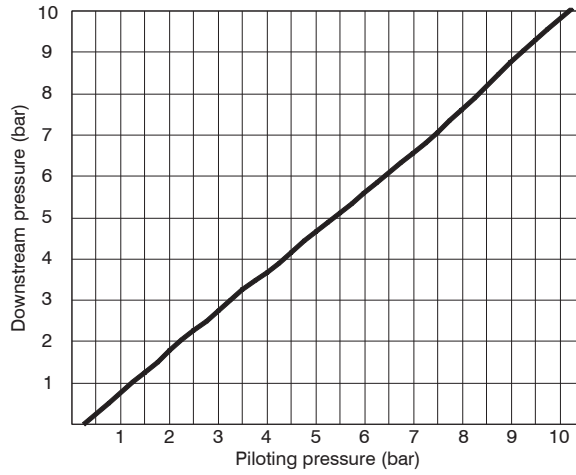

Size 4

► High sensitive pressure regulator with pneumatic pilot



- Accurate capacity to maintain set pressure
- Sensitivity combined with high relieving rates
- High flow rate with extremely low pressure drop
- Aluminium body
- Construction with controlled relief
- Atex certification (II 2GD) on request

Technical characteristics	Size
	Size 3
Body and connections type	Aluminium body, integrated aluminium connections
IN / OUT connections	G1/2"
Assembly configuration	Stand alone
Assembly position	Indifferent
Fluid	20µ filtered air and preferably non lubricated
Air flow with inlet pressure 10 bar (NI/min)	5
Pressure measurement	G1/8" Pressure gauge connection port
Max. fittings torque IN / OUT connections	G1/2" metal: 30

Operational characteristics	Size
	Size 3
Maximum working pressure (bar)	10
Minimum working pressure (bar)	0,5
Working temperature (°C)	-5 ÷ +50

Weights	Size
	Size 3
Aluminium body version (g)	970

2  
AIR TREATMENT



**Order codes**

17 **3P2B** .0010

**Size, body and connections**

3P2B : Aluminium body, connections G1/2" (only for size 3)

**Example: 173P2B.0010**

Size 3 high sensitive pressure regulator with pneumatic pilot, aluminium body, G1/2" connections

**Dimensions**

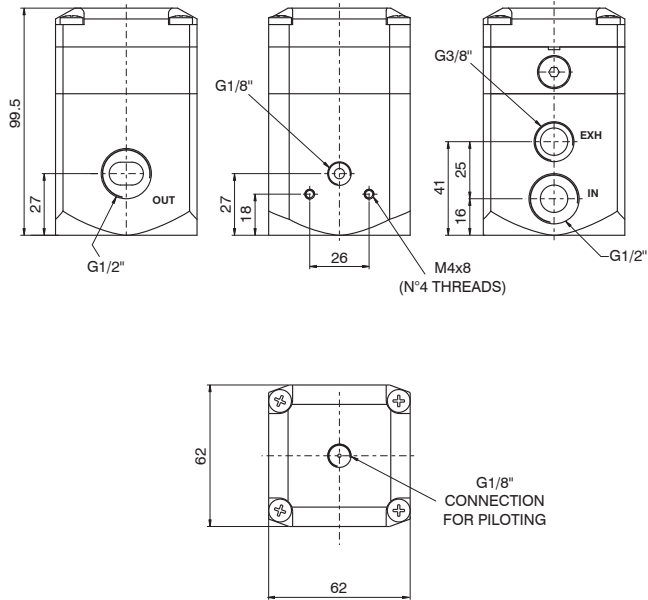

Size 3

**Characteristic curves**

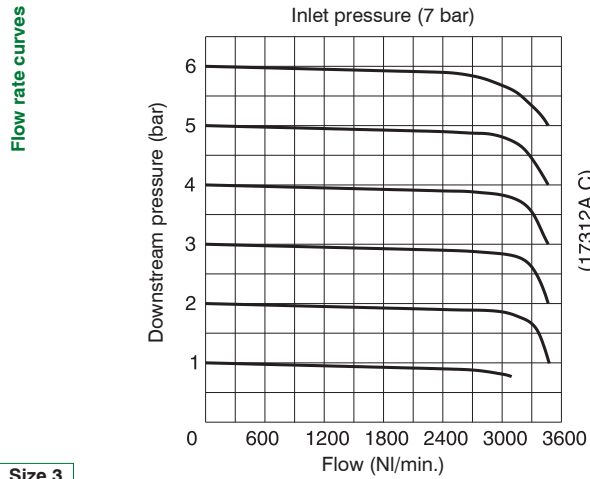

Size 3

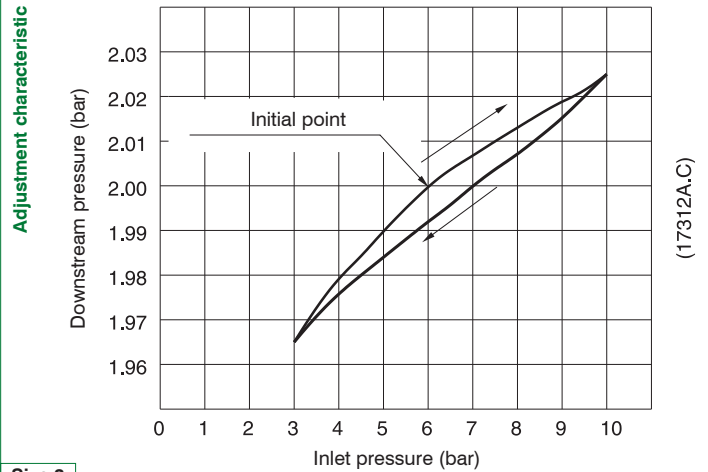

Size 3

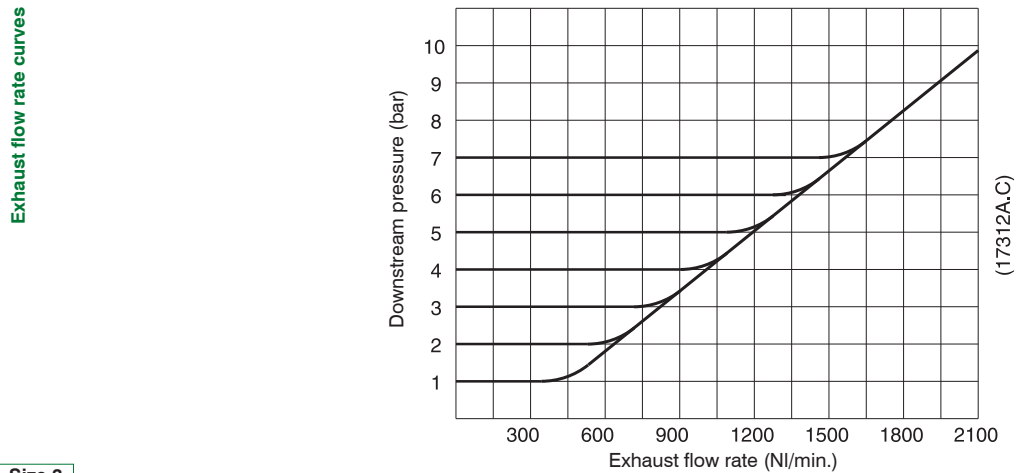

Size 3

▶ Panel mounting pressure regulator



- ▶ Diaphragm pressure regulator with relieving
- ▶ Balanced poppet
- ▶ Technopolymer body, metal connections
- ▶ Pressure adjusting lockable handle by simply pressing it downwards in the desired position
- ▶ Ring nut for panel mounting
- ▶ Atex certification (II 3GD) on request

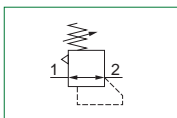

Technical characteristics	Size
	Size 1
Body and connections type	Technopolymer body, integrated metal connections
IN / OUT connections	G1/8" - G1/4"
Assembly configuration	Stand alone Panel mounting With fixing bracket
Assembly position	indifferent
Pressure range (bar)	0 - 2 / 0 - 4 / 0 - 8 / 0 - 12
Regulation	Manual push and lock with pressure Manual lockable with accessories
Pressure measurement	G1/8" Pressure gauge connection port
Max. fittings torque IN / OUT connections	G1/8" metal: 15 G1/4" metal: 20

Operational characteristics	Size
	Size 1
Maximum working pressure (bar)	13
Minimum working pressure (bar)	0,5
Working temperature (°C)	-5 ÷ +50

Weights	Size
	Size 1
Technopolymer body version (g)	110

**Order codes**

17 109A . D . L . K

**Size, body and connections**

**109A** : Technopolymer body, connections G1/8"  
**109B** : Technopolymer body, connections G1/4"

**Pressure range**

**A** : 0 - 2 bar  
**B** : 0 - 4 bar  
**C** : 0 - 8 bar  
**D** : 0 - 12 bar

**Type**

**L** : Without relieving  
**SM** : Improved relieving  
**SR** : Quick exhaust (Unbalanced poppet)  
**SRM** : Quick exhaust with improved relieving  
**SMF** : Improved relieving with controlled relief

**Options**

: Standard  
**K** : Lockable version  
**U** : Lockable version with universal key

**Example: 17109A.D.L.K**

Size 1 Panel mounting pressure regulator, technopolymer body, G1/8" connections, 0 - 12 bar, without relieving, Lockable version

**Dimensions**

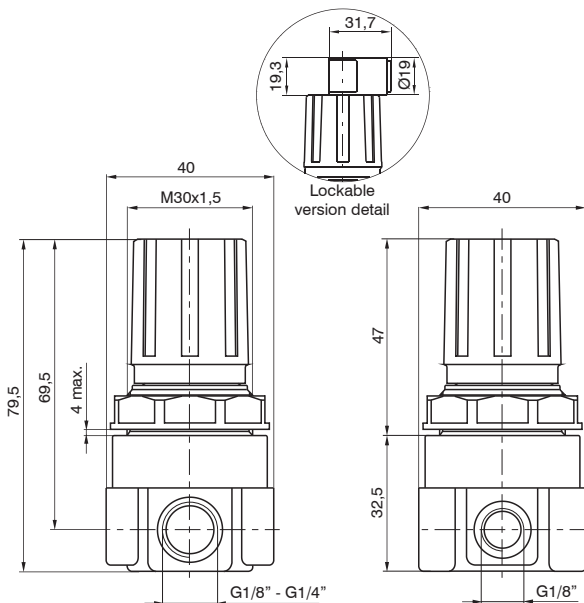

**Size 1**

**Characteristic curves**

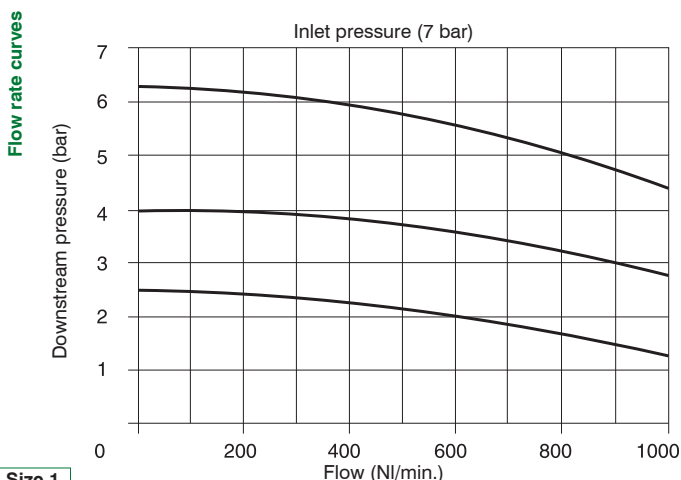

**Size 1**

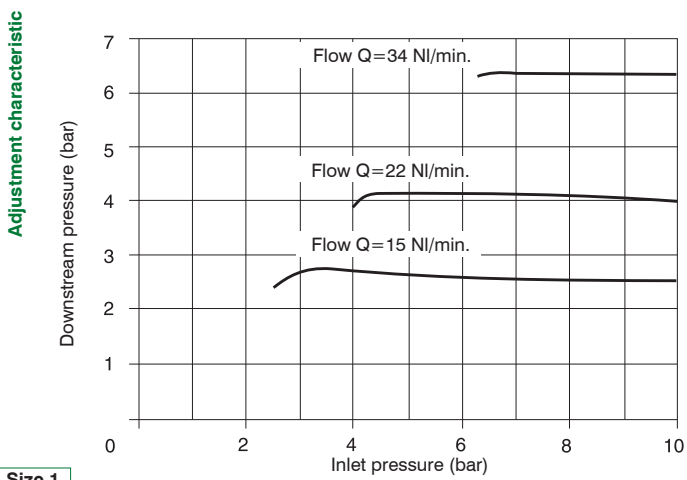

**Size 1**

AIR TREATMENT 2



▶ Panel mounting pressure regulator including pressure gauge



- ▶ Diaphragm pressure regulator with relieving
- ▶ Balanced poppet
- ▶ Technopolymer body with aluminum reinforced threaded connections
- ▶ Pressure adjusting lockable handle by simply pressing it downwards in the desired position
- ▶ Including pressure gauge integrated on the knob
- ▶ Ring nut for panel mounting
- ▶ Atex certification (II 3GD) on request

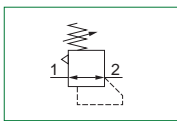

2  
AIR TREATMENT

Technical characteristics	Size
	Size 1
Body and connections type	Technopolymer body, aluminum reinforced threaded connections
IN / OUT connections	G1/8" - G1/4"
Assembly configuration	Stand alone Panel mounting With fixing bracket
Assembly position	Indifferent
Pressure range (bar)	0 - 2 / 0 - 4 / 0 - 8 / 0 - 12
Regulation	Manual push and lock with pressure
Pressure measurement	G1/8" Pressure gauge connection port integrated on the knob
Max. fittings torque IN / OUT connections	G1/8" metal: 15 G1/4" metal: 20

Operational characteristics	Size
	Size 1
Maximum working pressure (bar)	13
Minimum working pressure (bar)	0,5
Working temperature (°C)	-5 ÷ +50

Weights	Size
	Size 1
Technopolymer body version (g)	250

**Order codes**

17 129A . D

**Size, body and connections**

**129A** : Technopolymer body, connections G1/8"  
**129B** : Technopolymer body, connections G1/4"

**Pressure range**

**A** : 0 - 2 bar  
**B** : 0 - 4 bar  
**C** : 0 - 8 bar  
**D** : 0 - 12 bar

**Example: 17129A.D**

Size 1 panel mounting pressure regulator including pressure gauge, technopolymer body, G1/8" connections, 0 - 12 bar

**2 Dimensions**

AIR TREATMENT

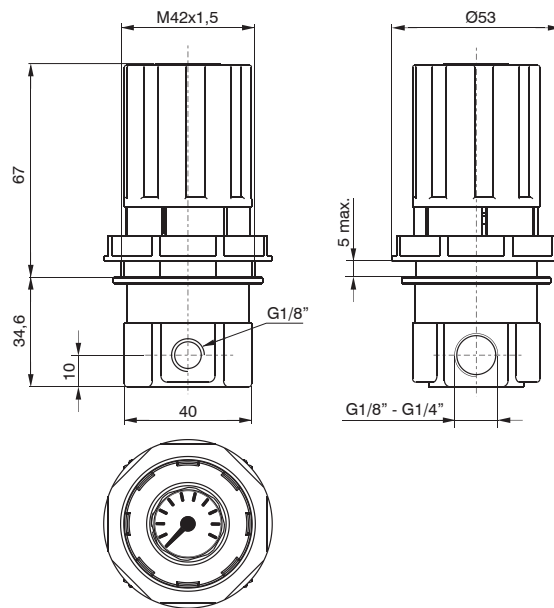

Size 1

**Characteristic curves**

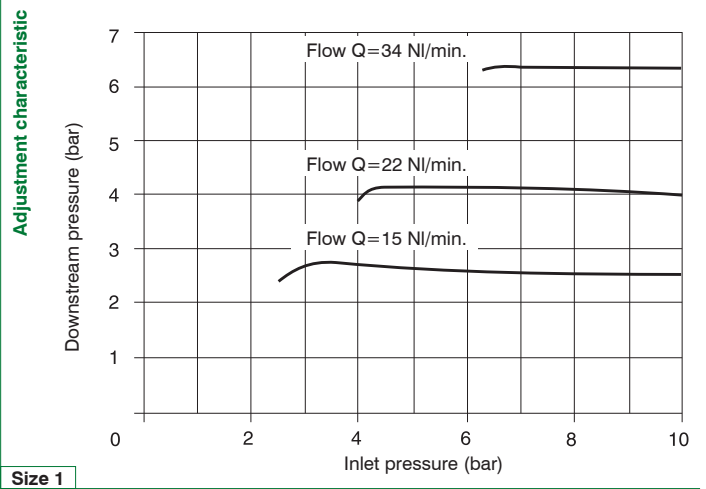
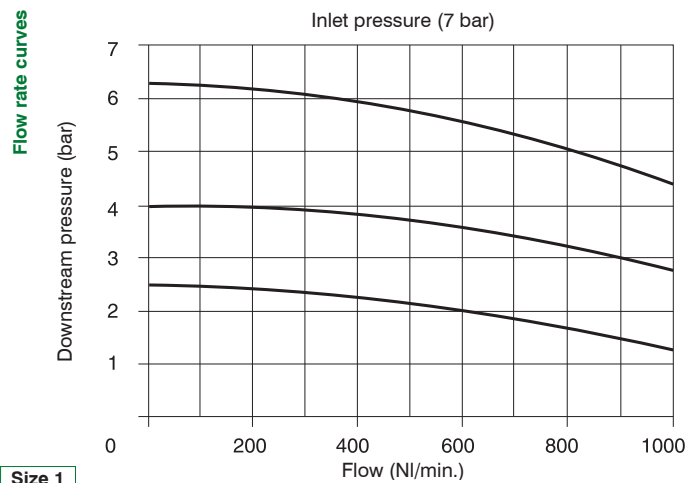

► Pressure regulators for manifold



- Diaphragm pressure regulator with relieving.
- Available with 2 front outputs connections G1/8"
- Available in four pressure ranges up to 12 bar
- Ring nut for panel mounting
- Available with integrated pressure gauge on the top of adjusting knob
- Air supply can be applied by both directions (Right or Left)
- Max. 6off pressure regulators in manifold configuration
- Atex certification (II 2GD) on request

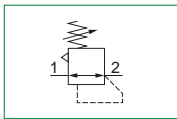

**Note**

For installations where a more accurate and constant pressure is required, the unit should be installed as close as possible to the point of use.

Technical characteristics	Size
	Size 1
Body and connections type	Zinc alloy body, integrated zinc alloy connections
IN / OUT connections	G1/8" - G1/4"
Assembly configuration	Stand alone Panel mounting Panel mounted with M4 screws With fixing bracket
Assembly position	Indifferent
Pressure range (bar)	0 - 2 / 0 - 4 / 0 - 8 / 0 - 12
Regulation	Manual push and lock with pressure Manual lockable with accessories (only for version without pressure gauge)
Pressure measurement	Integrated pressure gauge on the top of adjusting knob (optional)
Max. fittings torque IN / OUT connections	G1/8" metal: 15 G1/4" metal: 20

Operational characteristics	Size
	Size 1
Maximum working pressure (bar)	13
Minimum working pressure (bar)	0,5
Working temperature (°C)	-5 ÷ +50

Weights	Size
	Size 1
Zinc alloy body version (g)	380

2  
AIR TREATMENT

**Order codes**

17 **OB2A** . **D** . **K**

**Size, body and connections**

<b>OB2A</b> : Zinc alloy body, connections G1/8"
<b>OB2B</b> : Zinc alloy body, connections G1/4"
<b>OM2A</b> : Zinc alloy body, connections G1/8" with integrated pressure gauge
<b>OM2B</b> : Zinc alloy body, connections G1/4" with integrated pressure gauge

**Pressure range**

<b>A</b> : 0 - 2 bar
<b>B</b> : 0 - 4 bar
<b>C</b> : 0 - 8 bar
<b>D</b> : 0 - 12 bar

**Options**

: Standard
<b>K</b> : Lockable version (only for version without pressure gauge)
<b>U</b> : Lockable version with universal key (only for version without pressure gauge)

**Example: 17OB2A.D.K**

Size 1 pressure regulators for manifold, Zinc alloy body, G1/8" connections, 0 - 12 bar, without pressure gauge, Lockable version

**Dimensions**

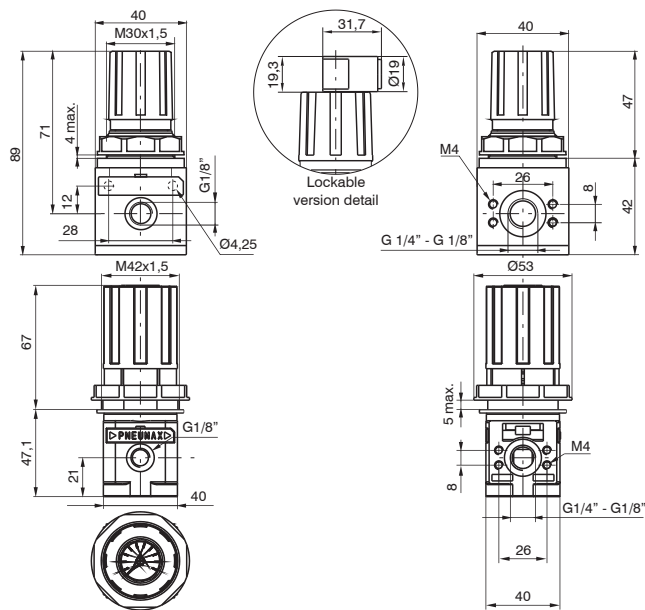

Size 1

**Characteristic curves**

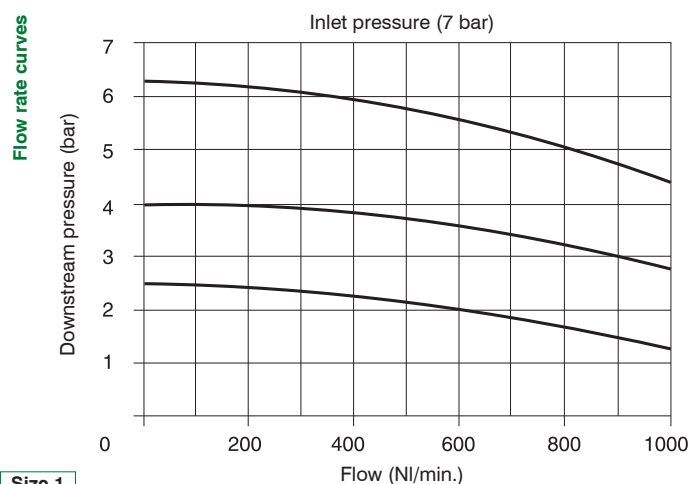

Size 1

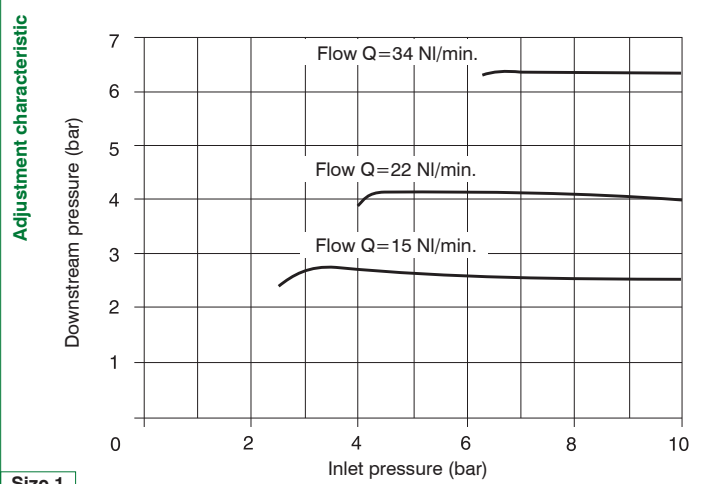

Size 1

2 AIR TREATMENT

▶ Manifold pressure regulators



- ▶ Manifold pressure regulators
- ▶ Available in four pressure ranges up to 12 bar
- ▶ Inlet pressure common for the whole manifold of pressure regulator
- ▶ A maximum of 6 pressure regulators can be mounted
- ▶ Atex certification (II 2GD) on request

Technical characteristics	Size
	Size 1
Body and connections type	Zinc alloy body, integrated zin alloy connections
IN / OUT connections	G1/8" - G1/4"
Assembly configuration	Stand alone Panel mounting Panel mounted with M4 screws With fixing bracket
Assembly position	indifferent
Pressure range (bar)	0 - 2 / 0 - 4 / 0 - 8 / 0 - 12
Regulation	Manual push and lock with pressure Manual lockable with accessories (only for version without pressure gauge)
Pressure measurement	G1/8" Pressure gauge connection port
Max. fittings torque IN / OUT connections	G1/8" metal: 15 G1/4" metal: 20

Operational characteristics	Size
	Size 1
Maximum working pressure (bar)	13
Minimum working pressure (bar)	0,5
Working temperature (°C)	-5 ÷ +50

2 AIR TREATMENT



**Order codes**

17 **BB2A** . **6** . **C** . **C** . **C** . **C** . **C** . **C** . **C** . **K**

**Size, body and connections**

<b>BB2A</b> : Zinc alloy body, connections G1/8"
<b>BB2B</b> : Zinc alloy body, connections G1/4"
<b>BM2A</b> : Zinc alloy body, connections G1/8" with integrated pressure gauge
<b>BM2B</b> : Zinc alloy body, connections G1/4" with integrated pressure gauge

**Number of regulators**

<b>2</b> : n. 2 Regulators
<b>3</b> : n. 3 Regulators
<b>4</b> : n. 4 Regulators
<b>5</b> : n. 5 Regulators
<b>6</b> : n. 6 Regulators

**Pressure range**

<b>A</b> : 0 - 2 bar
<b>B</b> : 0 - 4 bar
<b>C</b> : 0 - 8 bar
<b>D</b> : 0 - 12 bar

**Pressure range**

<b>A</b> : 0 - 2 bar
<b>B</b> : 0 - 4 bar
<b>C</b> : 0 - 8 bar
<b>D</b> : 0 - 12 bar

**Pressure range**

<b>A</b> : 0 - 2 bar
<b>B</b> : 0 - 4 bar
<b>C</b> : 0 - 8 bar
<b>D</b> : 0 - 12 bar

**Pressure range**

<b>A</b> : 0 - 2 bar
<b>B</b> : 0 - 4 bar
<b>C</b> : 0 - 8 bar
<b>D</b> : 0 - 12 bar

**Pressure range**

<b>A</b> : 0 - 2 bar
<b>B</b> : 0 - 4 bar
<b>C</b> : 0 - 8 bar
<b>D</b> : 0 - 12 bar

**Pressure range**

<b>A</b> : 0 - 2 bar
<b>B</b> : 0 - 4 bar
<b>C</b> : 0 - 8 bar
<b>D</b> : 0 - 12 bar

**Options**

: Standard
<b>K</b> : Lockable version (only for version without pressure gauge)
<b>U</b> : Lockable version with universal key (only for version without pressure gauge)

**Example : 17BB2A.6.C.C.C.C.C.C.K** : Size 1 manifold pressure regulators G1/8", 0 - 8 bar, without pressure gauge, Lockable version

2 AIR TREATMENT

Dimensions

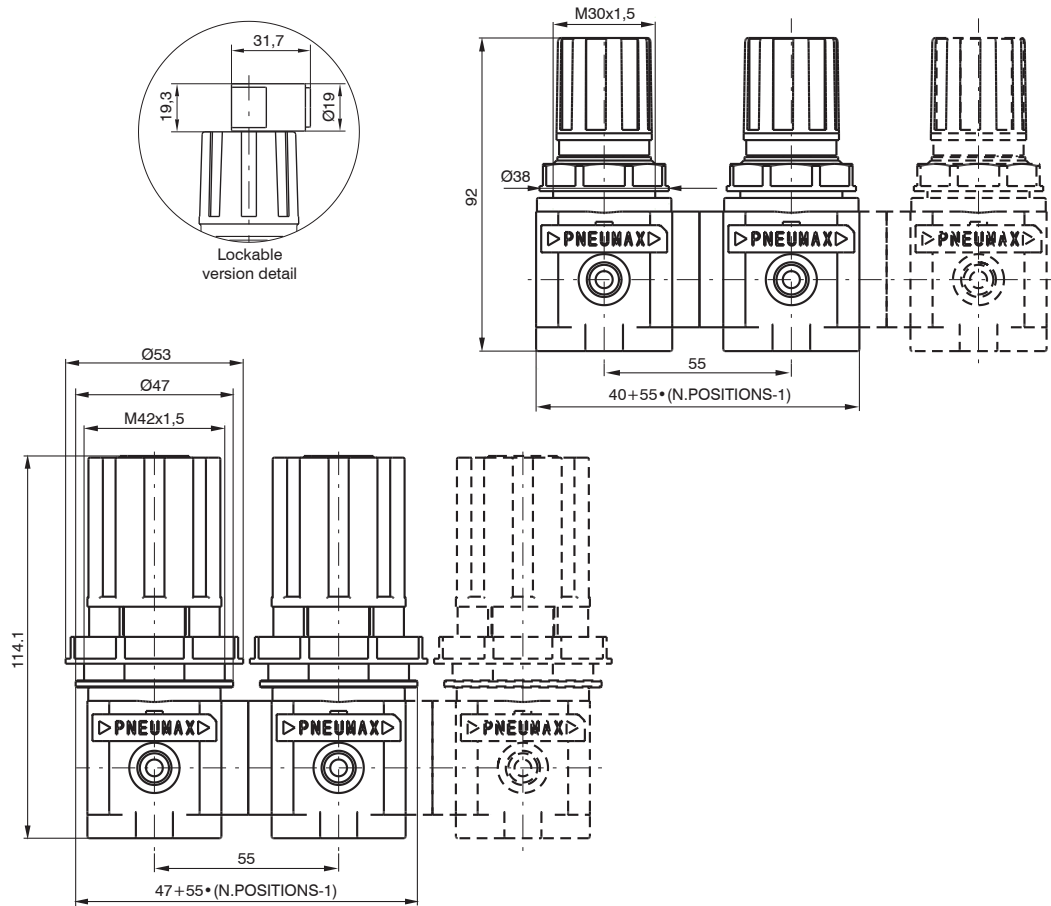

2

AIR TREATMENT

Size 1

Characteristic curves

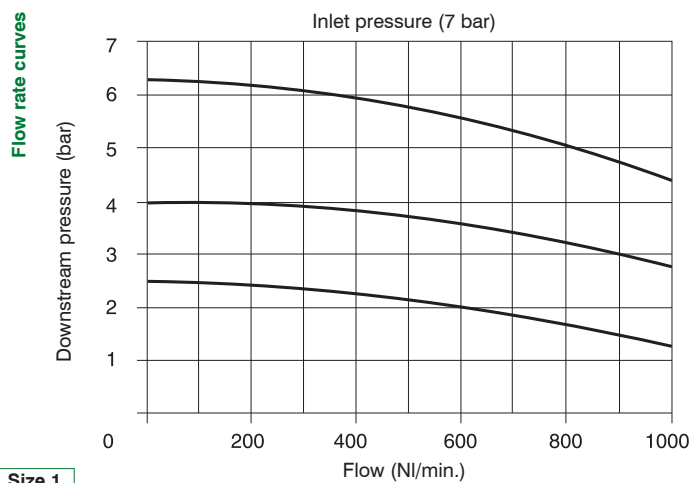

Size 1

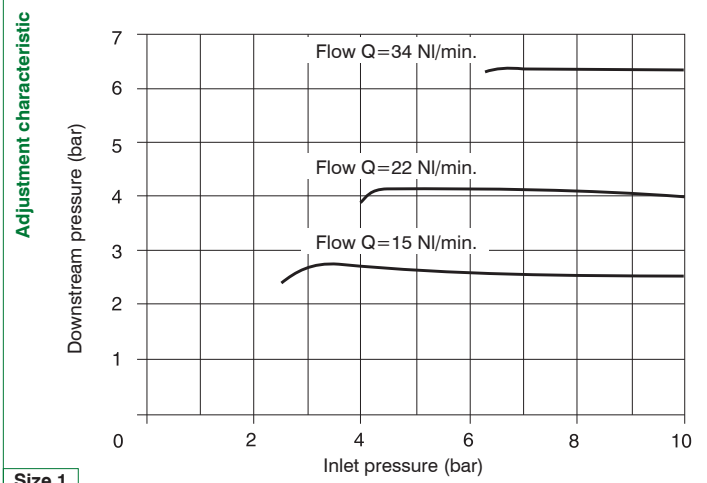

Size 1

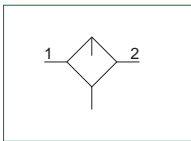

- ▶ Oil mist lubricator
- ▶ Available in 4 sizes with flow rates up to 10000 NI/min and connections from 1/8" to 1"
- ▶ Bowls screwed to the body (Size 1)
- ▶ Bowl assembly via bayonet type quick coupling mechanism with safety button (Size 2 - Size 3 - Size 4)
- ▶ Variable orifice size in function of the flow rate
- ▶ Oil quantity regulation mechanism and oil quantity visualization dome made of polycarbonate (PC)
- ▶ Oil refill plug
- ▶ Available with low level electrical sensor NO and NC
- ▶ Atex certification (II 2GD o II 3GD) on request

**2**
**AIR TREATMENT**

Technical characteristics	Size			
	Size 1	Size 2	Size 3	Size 4
<b>Body and connections type</b>	Zinc alloy body, Zinc alloy integrated connections Technopolymer body, metal connections	Aluminium body, integrated aluminium connections		
<b>Protection and bowl type</b>	Technopolymer protection - PA bowl (Size 1 available without protection)			Metal bowl with blind metal bowl
<b>IN / OUT connections</b>	G1/8" - G1/4"	G1/4" - G3/8"	G3/8" - G1/2", G3/4"	G1"
<b>Assembly configuration</b>	Stand alone Panel mounted with M4 screws	Stand alone Panel mounted with M5 screws	Stand alone Panel mounted with M6 screws	Stand alone Panel mounted with M8 screws
<b>Assembly position</b>	Vertical ±5°			
<b>Bowl capacity (cm³)</b>	36	52	62	300
<b>Lubrication type</b>	Oil mist			
<b>Oil level regulation</b>	Manual, complete with visual indicator			
<b>Max. fittings torque IN / OUT connections</b>	G1/8" metal: 15 G1/4" metal: 20	G1/4" metal: 20 G3/8" metal: 25	G3/8" metal: 25 G1/2" metal: 30 G3/4" metal: 35	G1" metal: 35

Operational characteristics	Size			
	Size 1	Size 2	Size 3	Size 4
<b>Maximum working pressure (bar)</b>	13			
<b>Minimum working pressure (bar)</b>	0,5			
<b>Min.operational flow at 6,3 bar (NI/min)</b>	10	20	100	
<b>Indicative oil drop rate (NI/min)</b>	1 drope every 300/600			
<b>Oil type</b>	FD22 - HG32			
<b>Working temperature (°C)</b>	-5 ÷ +50			

Weights	Size			
	Size 1	Size 2	Size 3	Size 4
Zinc alloy body version (g)	258	/	/	/
Technopolymer body version (g)	108	/	/	/
Aluminium body version (g)	/	280	435	1500





Order codes

17 303A . MA

Size, body and connections
003A : Zinc alloy body, connections G1/8" (only for size 1)
003B : Zinc alloy body, connections G1/4" (only for size 1)
103A : Technopolymer body, connections G1/8" (only for size 1)
103B : Technopolymer body, connections G1/4" (only for size 1)
203A : Aluminium body, connections G1/4" (only for size 2)
203B : Aluminium body, connections G3/8" (only for size 2)
303A : Aluminium body, connections G3/8" (only for size 3)
303B : Aluminium body, connections G1/2" (only for size 3)
303E : Aluminium body, connections G3/4" (only for size 3)
403B : Aluminium body, connections G1" (only for size 4)

Type
P : Protected bowl (only for size 1)
MA : Electrical minimum level sensor NO (not available for Size 1)
MC : Electrical minimum level sensor NC (not available for Size 1)

**Example: 17303A.MA**

Size 3 Lubricator, Aluminium body, G3/8" connections, normally open low level electrical sensor

**Dimensions**

2

AIR TREATMENT

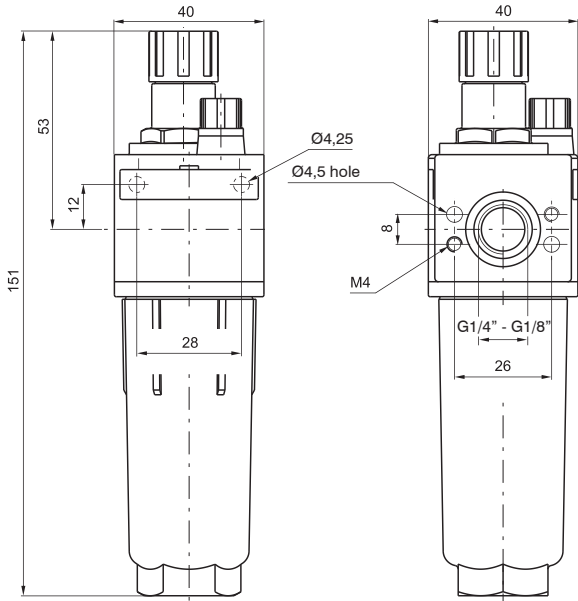

**Size 1**

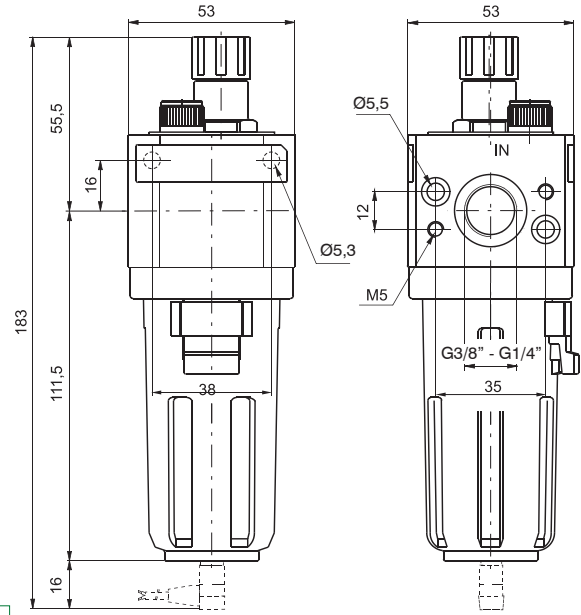

**Size 2**

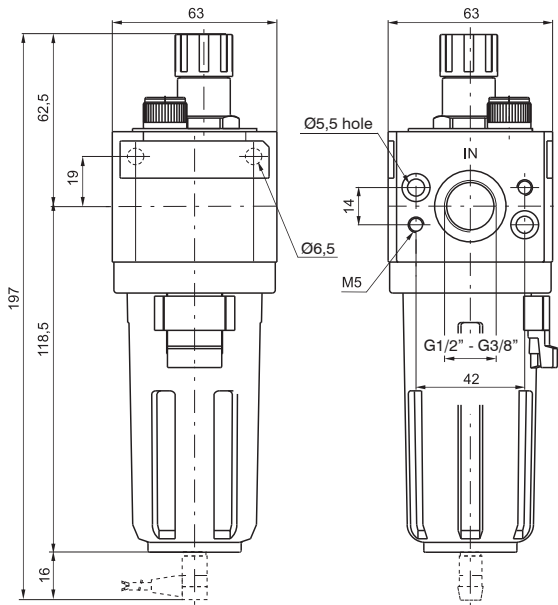

**Size 3**

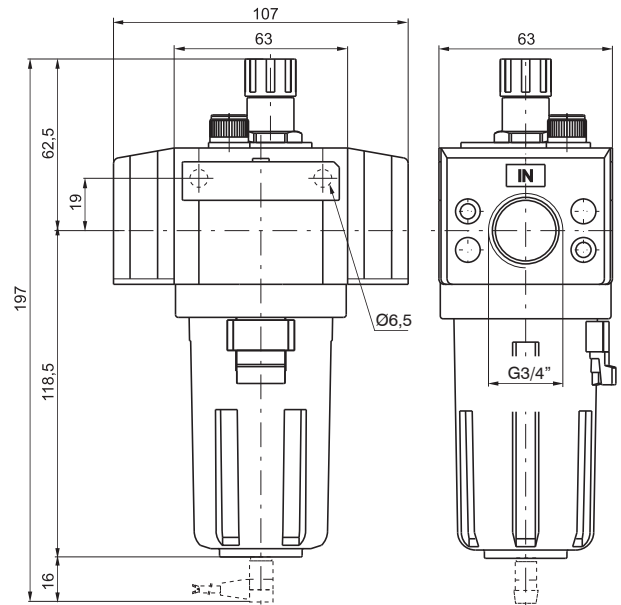

**Size 3 3/4"**

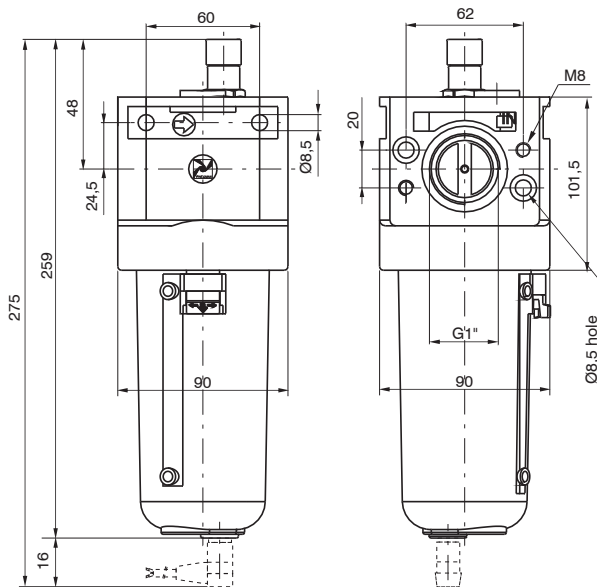

**Size 4**



Characteristic curves

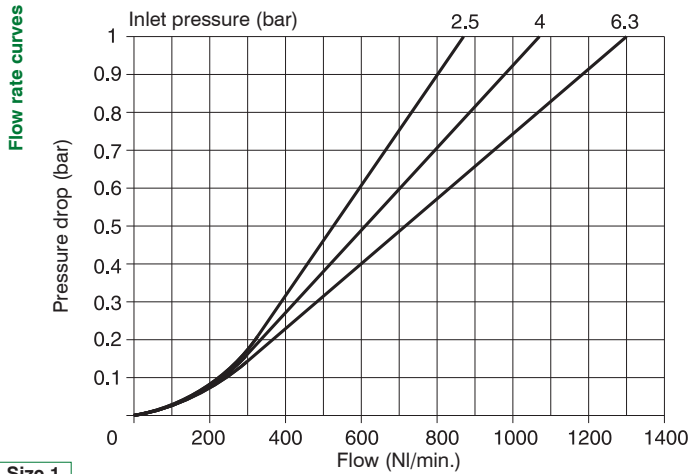

Size 1

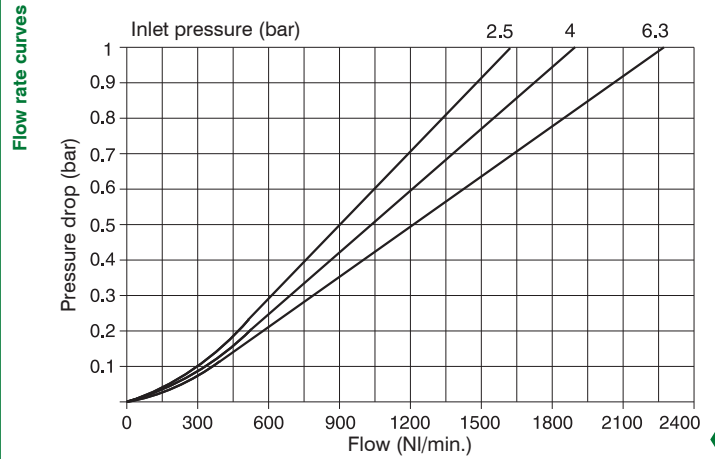

Size 2

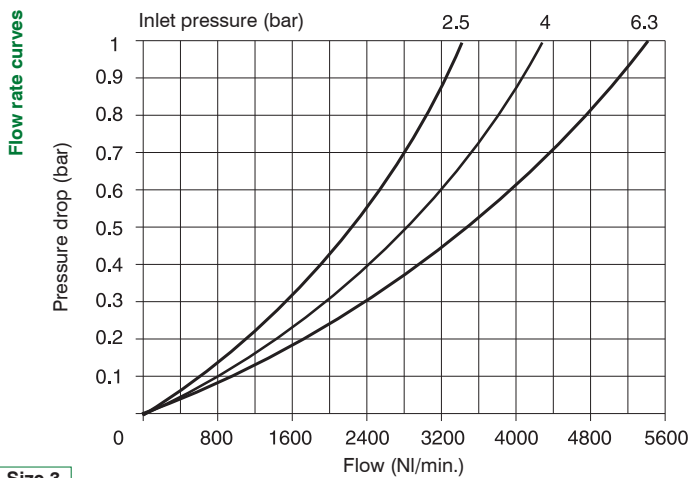

Size 3

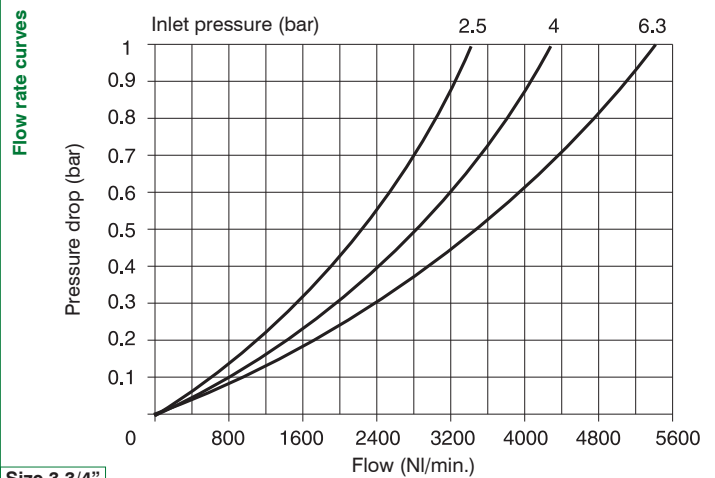

Size 3 3/4"

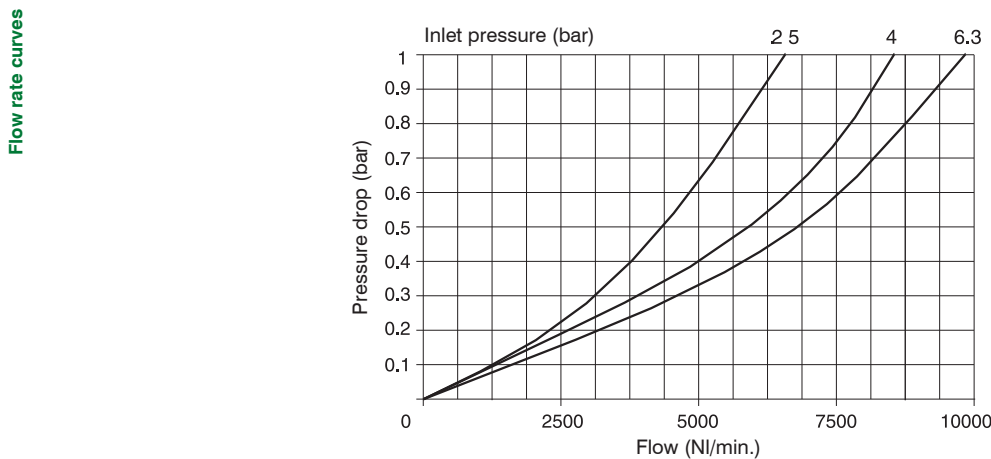

Size 4

2

AIR TREATMENT

**Shut-off valve**

- ▶ 3/2 N.C. poppet valve for opening and exhausting the circuit
- ▶ Allows to pneumatically supply the part of the system downstream of the valve
- ▶ Manual adjusting lockable handle (in shut-off position) with a maximum of three pad-locks
- ▶ Atex certification (II 2GD o II 3GD) on request

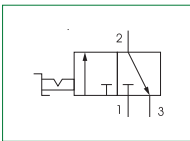
**2**
**AIR TREATMENT**

Technical characteristics	Size			
	Size 1	Size 2	Size 3	Size 4
<b>Body and connections type</b>	Zinc alloy body, Zinc alloy integrated connections Technopolymer body, metal connections	Aluminium body, integrated aluminium connections		
<b>Operated type</b>	Manual			
<b>IN / OUT connections</b>	G1/4"	G3/8"	G1/2"	G1"
<b>Discharge connections</b>	G1/8"	G1/4"	G3/8"	G1/4"
<b>Assembly configuration</b>	Stand alone Panel mounted with M4 screws	Stand alone Panel mounted with M5 screws	Stand alone Panel mounted with M6 screws	Stand alone Panel mounted with M8 screws
<b>Assembly position</b>	Indifferent			
<b>Max. fittings torque IN / OUT connections</b>	G1/4" metal: 20	G3/8" metal: 25	G1/2" metal: 30	G1" metal: 35

Operational characteristics	Size			
	Size 1	Size 2	Size 3	Size 4
<b>Maximum working pressure (bar)</b>	13			10
<b>Minimum working pressure (bar)</b>	0,5			
<b>Nominal flow rate at 6 bar with Δp=1 (NI/min)</b>	1000	2100	2500	8000
<b>Working temperature (°C)</b>	-5 ÷ +50			

Weights	Size			
	Size 1	Size 2	Size 3	Size 4
Zinc alloy body version (g)	280	/	/	/
Technopolymer body version (g)	155	/	/	/
Aluminium body version (g)	/	380	550	1600

Order codes

17 330 . A

Size, body and connections

030 : Zinc alloy body, connections G1/4" (only for size 1)
130 : Technopolymer body, connections G1/4" (only for size 1)
230 : Aluminium body, connections G3/8" (only for size 2)
330 : Aluminium body, connections G1/2" (only for size 3)
430 : Aluminium body, connections G1" (only for size 4)

Type

A : Not lockable handle
B : Lockable handle

Example: 17330.A

Shut-off valve Size 3, Aluminium body, G1/2" connections, with not lockable handle

Dimensions

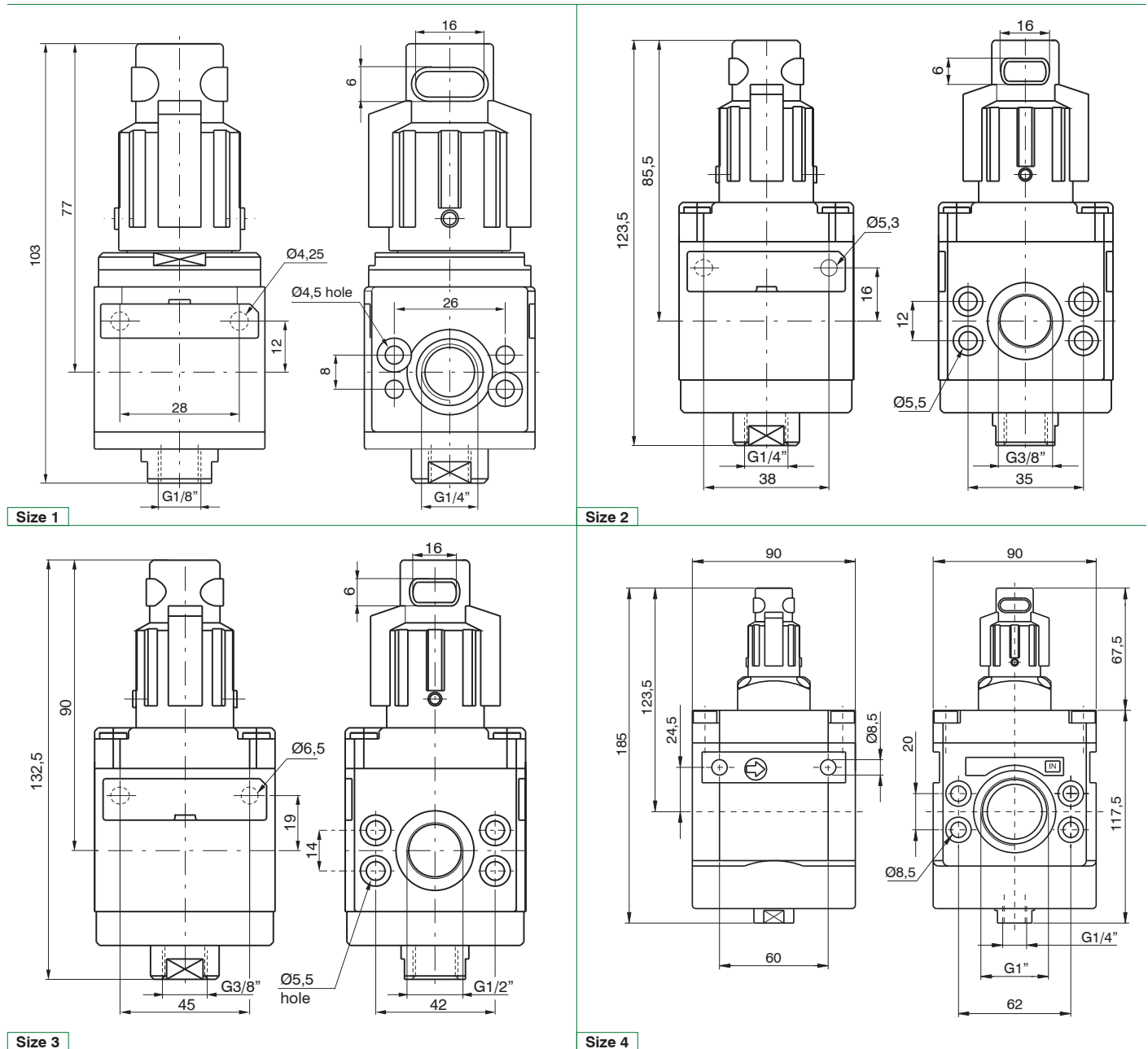

**Electric shut-off valve**

- ▶ 3/2 N.C. poppet valve for entering and exhausting the circuit
- ▶ It allows to pneumatically supply the part of the system downstream of the valve
- ▶ Opening and closing of the valve via solenoid operator
- ▶ The supply pressure must be minimum 2 bars or higher
- ▶ It is possible to produce the external supplied solenoid version by mounting the 305.10.05 between the valve main body and the solenoid pilot valve.
- ▶ The air supply can only be done via port 1
- ▶ Ensure that the downstream air consumption will not cause a pressure drop which could result in the pressure falling below the minimum operating values.
- ▶ If the pressure inside the valve falls below 2 bars , the valve might shut off.
- ▶ Atex certification (II 2GD o II 3GD) on request

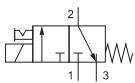
**2**
**AIR TREATMENT**

Technical characteristics	Size		
	Size 1	Size 2	Size 3
<b>Body and connections type</b>	Zinc alloy body, Zinc alloy integrated connections Technopolymer body, metal connections	Aluminium body, integrated aluminium connections	
<b>Operated type</b>	Electric		
<b>IN / OUT connections</b>	G1/4"	G3/8"	G1/2"
<b>Discharge connections</b>	G1/8"	G1/4"	G3/8"
<b>Assembly configuration</b>	Stand alone Panel mounted with M4 screws	Stand alone Panel mounted with M5 screws	Stand alone Panel mounted with M6 screws
<b>Assembly position</b>	Indifferent		
<b>Max. fittings torque IN / OUT connections</b>	G1/4" metal: 20	G3/8" metal: 25	G1/2" metal: 30

Operational characteristics	Size		
	Size 1	Size 2	Size 3
<b>Maximum working pressure (bar)</b>	10		
<b>Minimum working pressure (bar)</b>	2		
<b>Nominal flow rate at 6 bar with Δp=1 (NI/min)</b>	1000	2100	3200
<b>Working temperature (°C)</b>	-5 ÷ +50		

Weights	Size		
	Size 1	Size 2	Size 3
Zinc alloy body version (g)	345	/	/
Technopolymer body version (g)	215	/	/
Aluminium body version (g)	/	440	680

Order codes

17 330 . M2

Size, body and connections

- 030 : Zinc alloy body, connections G1/4" (only for size 1)
- 130 : Technopolymer body, connections G1/4" (only for size 1)
- 230 : Aluminium body, connections G3/8" (only for size 2)
- 330 : Aluminium body, connections G1/2" (only for size 3)

Type

- M2 : Electric with M2
- M2/9 : Electric with M2/9

Example: 17330.M2

Electric shut-off valve Size 3, Aluminium body, G1/2" connections, electric with M2

Dimensions

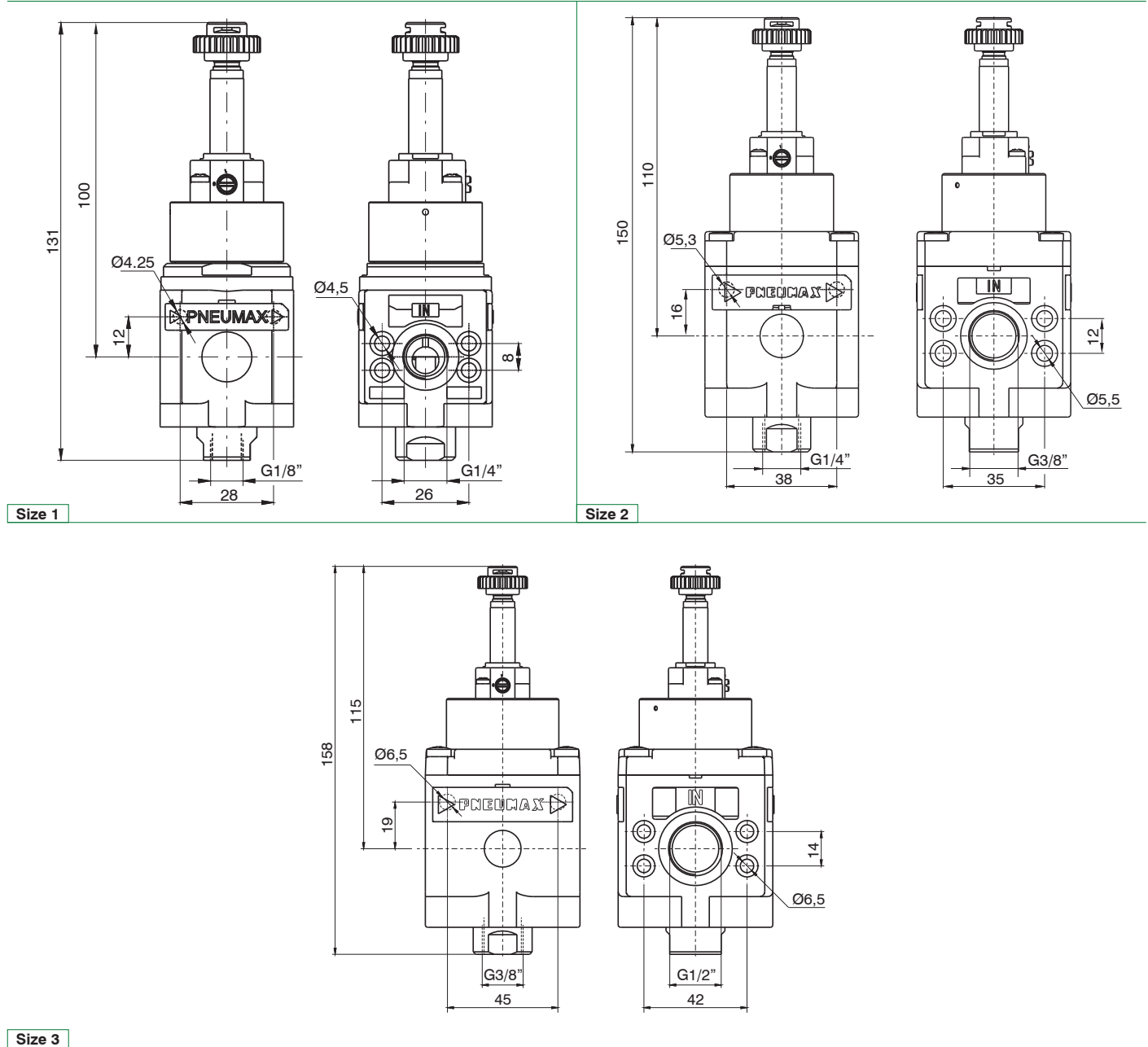

**Pneumatic shut-off valve**

- ▶ 3/2 N.C. poppet valve for entering and exhausting the circuit
- ▶ It allows to pneumatically supply the part of the system downstream of the valve
- ▶ Opening and closing of the valve via pneumatic operator
- ▶ The piloting pressure must be minimum 2 bar or higher
- ▶ The air supply can only be done via port 1
- ▶ Ensure that the downstream air consumption will not cause a pressure drop which could result in the pressure falling below the minimum operating values
- ▶ If the pressure inside the valve falls below 2 bars , the valve might shut off
- ▶ Atex certification (II 2GD o II 3GD) on request

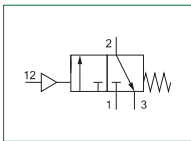
**2**
**AIR TREATMENT**

Technical characteristics	Size		
	Size 1	Size 2	Size 3
<b>Body and connections type</b>	Zinc alloy body, Zinc alloy integrated connections Technopolymer body, metal connections	Aluminium body, integrated aluminium connections	
<b>Operated type</b>	Pneumatic		
<b>IN / OUT connections</b>	G1/4"	G3/8"	G1/2"
<b>Discharge connections</b>	G1/8"	G1/4"	G3/8"
<b>Pilot connections</b>	G1/8"		
<b>Assembly configuration</b>	Stand alone Panel mounted with M4 screws	Stand alone Panel mounted with M5 screws	Stand alone Panel mounted with M6 screws
<b>Assembly position</b>	Indifferent		
<b>Max. fittings torque IN / OUT connections</b>	G1/4" metal: 20	G3/8" metal: 25	G1/2" metal: 30

Operational characteristics	Size		
	Size 1	Size 2	Size 3
<b>Maximum working pressure (bar)</b>	13		
<b>Minimum working pressure (bar)</b>	2		
<b>Piloting pressure (bar)</b>	2		
<b>Nominal flow rate at 6 bar with Δp=1 (NI/min)</b>	1000	2100	3200
<b>Working temperature (°C)</b>	-5 ÷ +50		

Weights	Size		
	Size 1	Size 2	Size 3
Zinc alloy body version (g)	310	/	/
Technopolymer body version (g)	180	/	/
Aluminium body version (g)	/	405	645



Order codes

17 **330** .PN

**Size, body and connections**

**030** : Zinc alloy body, connections G1/4" (only for size 1)

**130** : Technopolymer body, connections G1/4" (only for size 1)

**230** : Aluminium body, connections G3/8" (only for size 2)

**330** : Aluminium body, connections G1/2" (only for size 3)

**Example: 17330.PN**

Pneumatic shut-off valve Size 3, Aluminium body, G1/2" connections, with pneumatic pilot

Dimensions

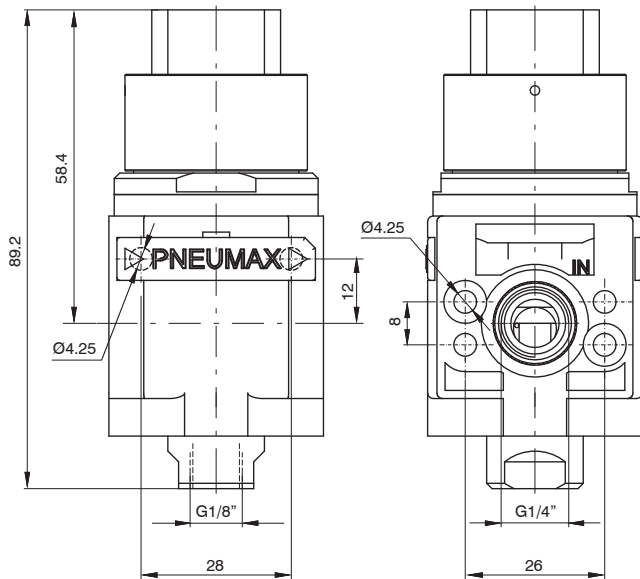

Size 1

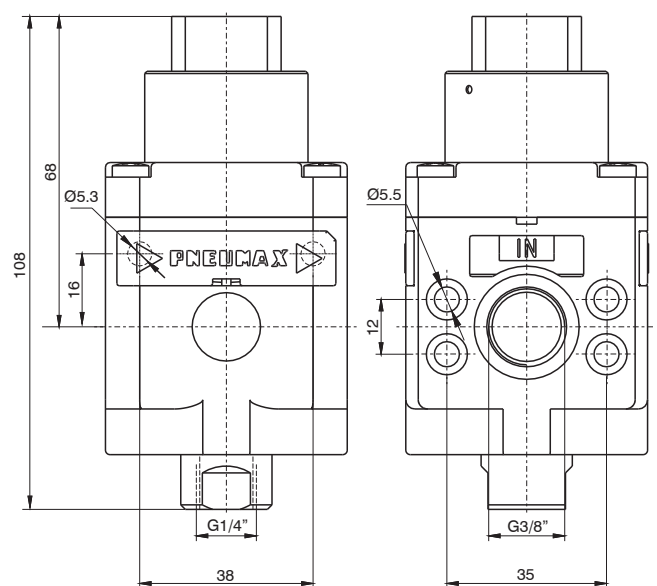

Size 2

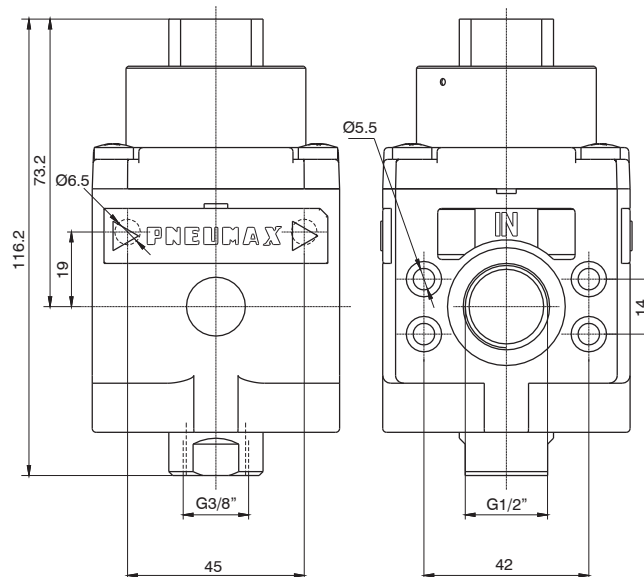

Size 3

**Progressive start-up valve**

- ▶ 3 way valve with double poppet
- ▶ Aluminium body
- ▶ Possibility to adjust the down stream circuit filling time by the enclosed adjustable metering screw
- ▶ Quick down stream circuit discharge
- ▶ Possibility for a pneumatic or electric piloting control
- ▶ Atex certification (II 2GD o II 3GD) on request

**AIR TREATMENT**
**2**

Technical characteristics	Size			
	Size 1	Size 2	Size 3	Size 4
Body and connections type	Aluminium body, integrated aluminium connections			
IN / OUT connections	G1/4"	G3/8"	G1/2"	G1"
Discharge connections	G1/8"	G1/4"	G3/8"	G3/4"
Assembly configuration	Stand alone Panel mounted with M4 screws	Stand alone Panel mounted with M5 screws	Stand alone Panel mounted with M6 screws	Stand alone Panel mounted with M8 screws
Assembly position	Indifferent			
Max. fittings torque IN / OUT connections	G1/4" metal: 20	G3/8" metal: 25	G1/2" metal: 30	G1" metal: 35

Operational characteristics	Size			
	Size 1	Size 2	Size 3	Size 4
Maximum working pressure (bar)	10			
Minimum working pressure (bar)	2,5			
Nominal flow rate at 6 bar with $\Delta p=1$ (NI/min)	1000	1700	2500	8000
Flow with adjustable metering screw fully open (NI/min)	150	340		3000
Working temperature (°C)	-5 ÷ +50			

Weights	Size			
	Size 1	Size 2	Size 3	Size 4
Aluminium body version (g)	365	595	1010	2300

Order codes

17 **3** **20**

Size, body and connections
1 : Aluminium body, connections G1/4" (only for size 1)
2 : Aluminium body, connections G3/8" (only for size 2)
3 : Aluminium body, connections G1/2" (only for size 3)
4 : Aluminium body, connections G1" (only for size 4)
Type
10.M2 : Electric control complete with M2 mechanic
20 : Pneumatic pilot

**Example: 17320**

Progressive start-up valve Size 3, Aluminium body, G1/2" connections, with pneumatic pilot

Dimensions

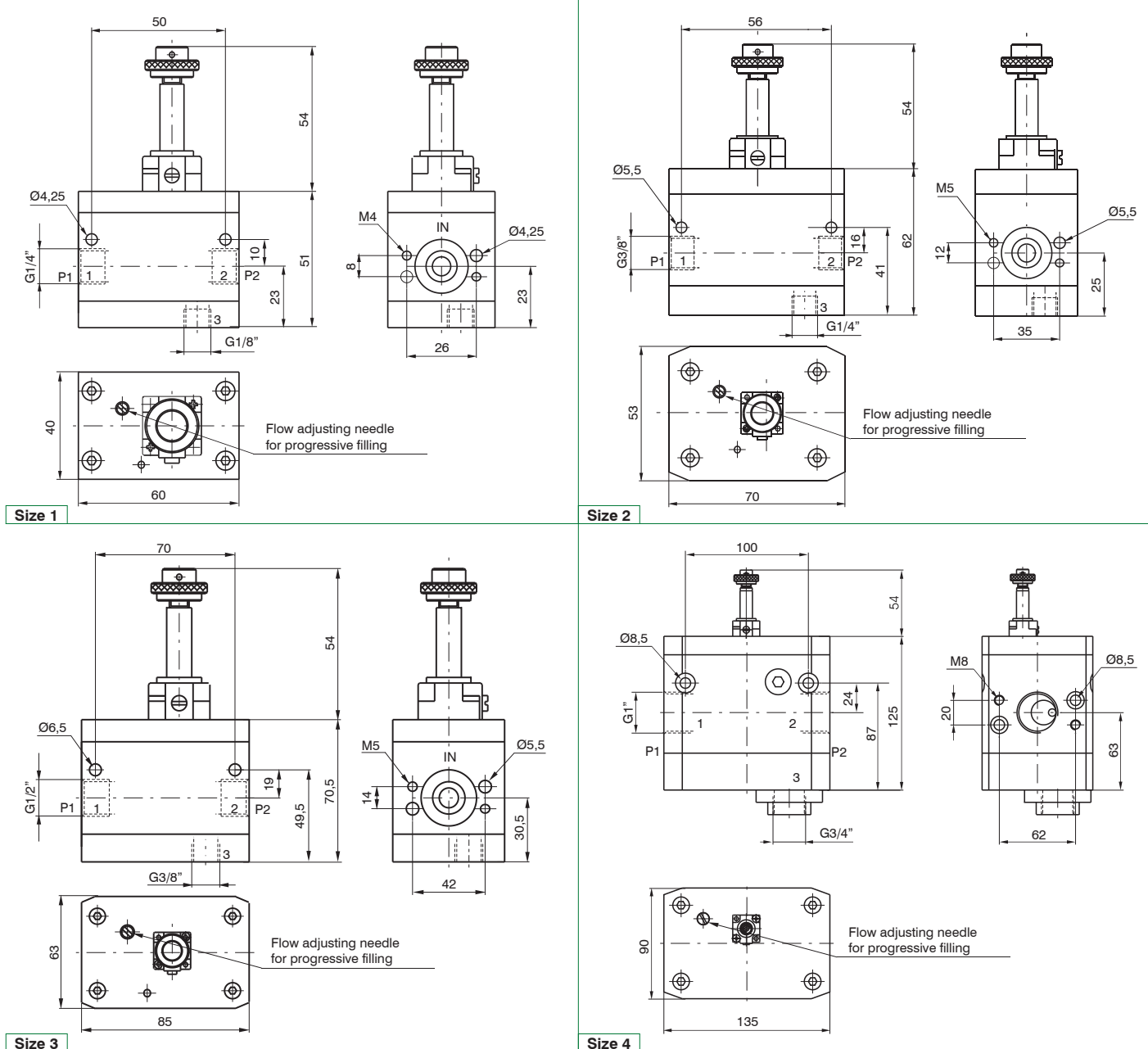



► **Air Intake**



- Pneumatic by-pass
- Available with 2 threaded connections

2

AIR TREATMENT

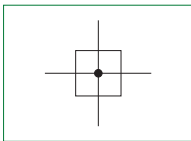

Technical characteristics	Size			
	Size 1	Size 2	Size 3	Size 4
Body and connections type	Aluminium body, integrated aluminium connections			
IN / OUT Connections	G1/4"	G3/8"	G1/2"	G1"
INTAKE connections	G1/8"	G1/4"	G3/8"	G3/4"
Assembly configuration	Stand alone	Stand alone	Stand alone	Stand alone
Assembly position	Indifferent			
Max. fittings torque IN / OUT connections	G1/4" metal: 20	G3/8" metal: 25	G1/2" metal: 30	G1" metal: 35

Operational characteristics	Size			
	Size 1	Size 2	Size 3	Size 4
Maximum working pressure (bar)	13			
Working temperature (°C)	-5 ÷ +50			

Weights	Size			
	Size 1	Size 2	Size 3	Size 4
Aluminium body version (g)	78	159	271	761

Order codes

17 **3** 40

**Size, body and connections**

- |   |
|---|
| 1 : Aluminium body, connections G1/4" (only for size 1) |
| 2 : Aluminium body, connections G3/8" (only for size 2) |
| 3 : Aluminium body, connections G1/2" (only for size 3) |
| 4 : Aluminium body, connections G1" (only for size 4)   |

**Example: 17340**

Air Intake Size 3, Aluminium body, G1/2" connections

Dimensions

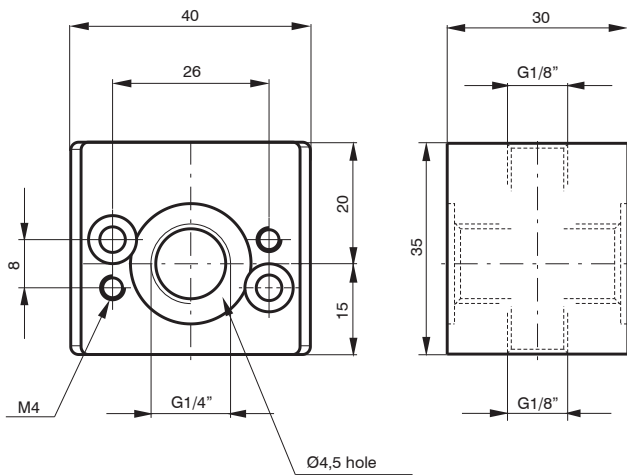

Size 1

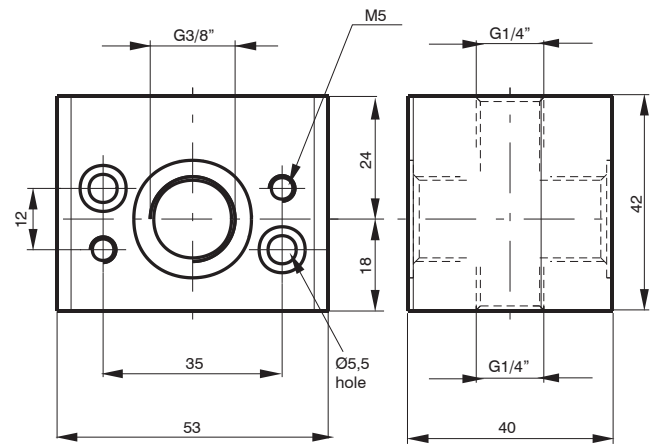

Size 2

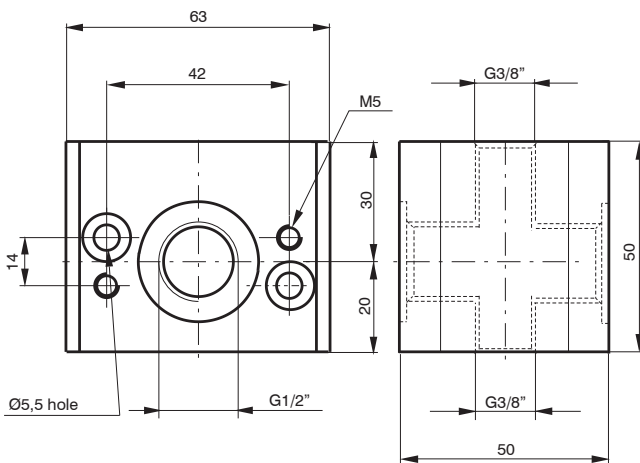

Size 3

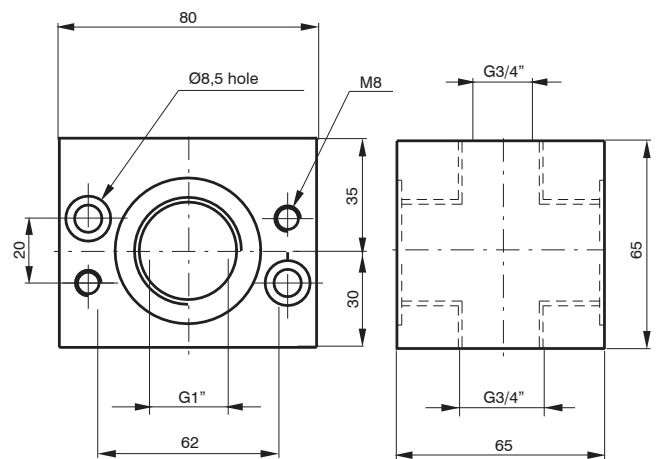

Size 4

2

AIR TREATMENT



▶ **Air Intake -“H” profile**



- ▶ Pneumatic by-pass
- ▶ Available with 2 threaded connections

2

AIR TREATMENT

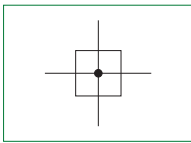

Technical characteristics	Size		
	Size 1	Size 2	Size 3
Body and connections type	Aluminium body		
IN / OUT Connections	G1/4"	G3/8"	G1/2"
INTAKE connections	G1/8"	G1/4"	G3/8"
Assembly configuration	Stand alone	Stand alone	Stand alone
Assembly position	Indifferent		
Max. fittings torque IN / OUT connections	G1/4" metal: 20	G3/8" metal: 25	G1/2" metal: 30

Operational characteristics	Size		
	Size 1	Size 2	Size 3
Maximum working pressure (bar)	13		
Working temperature (°C)	-5 ÷ +50		

Weights	Size		
	Size 1	Size 2	Size 3
Aluminium body version (g)	50	116	192

Order codes

17 **3** 40H

Size, body and connections

- 1 : Aluminium body, connections G1/4" (only for size 1)
- 2 : Aluminium body, connections G3/8" (only for size 2)
- 3 : Aluminium body, connections G1/2" (only for size 3)

Example: 17340H

Air Intake -"H" profile Size 3, Aluminium body, G1/2" connections

Dimensions

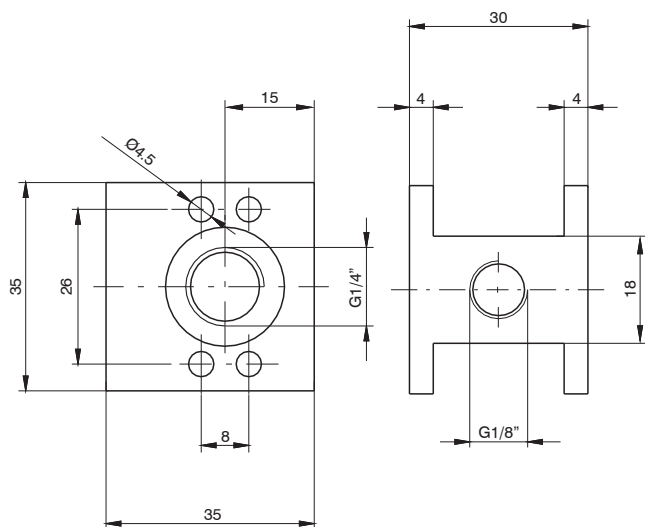

Size 1

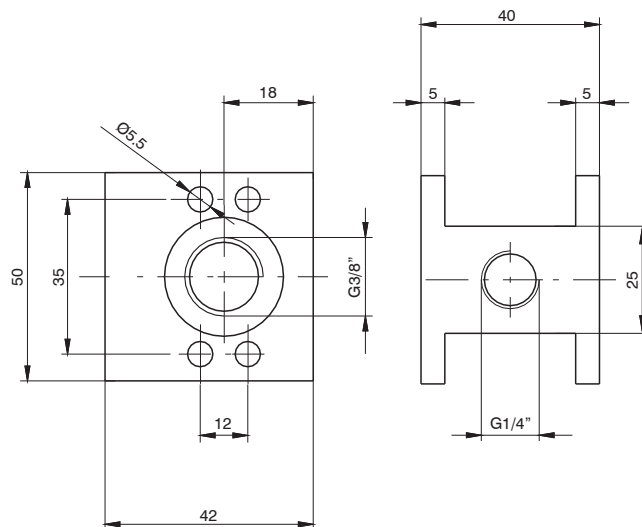

Size 2

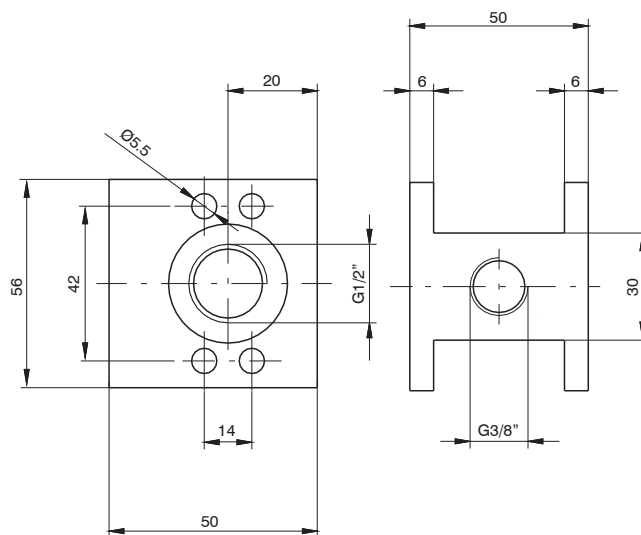

Size 3

2

AIR TREATMENT



► **Pressure Switch complete with adapter**



- The pressure switch can be set at desired pressure from 2 to 10 bar with electrical connection applied
- The electrical connection is made by mean of a 15 mm connector DIN 43650 type C
- The microswitch contact could be Normally Closed or open (change over switch)

2

AIR TREATMENT

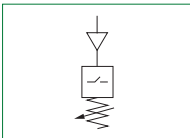

Technical characteristics	Size			
	Size 1	Size 2	Size 3	Size 4
Body and connections type	Aluminium body			
IN / OUT Connections	G1/8"	G3/8"	G1/2"	Ø36
Assembly configuration	Stand alone	Stand alone	Stand alone	Stand alone
Assembly position	Indifferent			
Microswitch capacity (A)	1			
Microswitch Maximum voltage (VAC)	250			
Grade of protection	IP65 (with connector assembled)			

Operational characteristics	Size			
	Size 1	Size 2	Size 3	Size 4
Maximum working pressure (bar)	13			
Working temperature (°C)	-5 ÷ +50			
Pressure range (bar)	2 ÷ 10			

Weights	Size			
	Size 1	Size 2	Size 3	Size 4
Aluminium body version (g)	160	200	220	450

**Order codes**

17 **34C**

Type
14A : Pressure switch adapter (only for size 1)
14B : Pressure switch (for all sizes)
14C : Pressure switch complete with adapter (only for size 1)
24A : Pressure switch adapter (only for size 2)
24C : Pressure switch complete with adapter (only for size 2)
34A : Pressure switch adapter (only for size 3)
34C : Pressure switch complete with adapter (only for size 3)
44A : Pressure switch adapter (only for size 4)
44C : Pressure switch complete with adapter (only for size 4)

**Example: 1734C**

Pressure switch adapter size 3



Electrical connection

1 = neutral  
2 = N.C. contact  
3 = N.O. contact

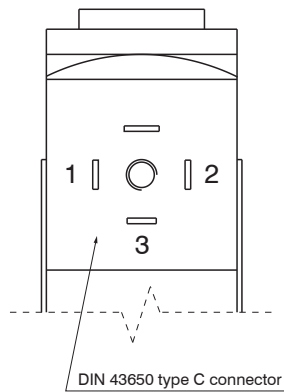

Dimensions

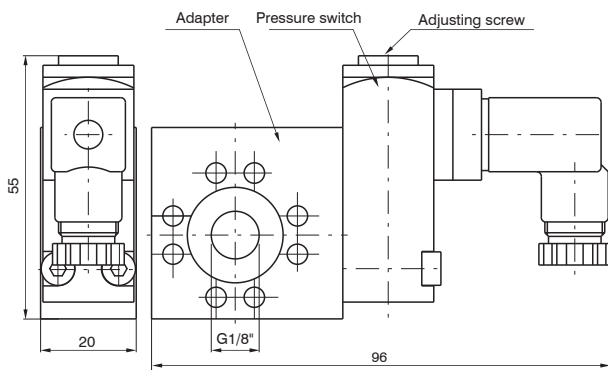

Size 1

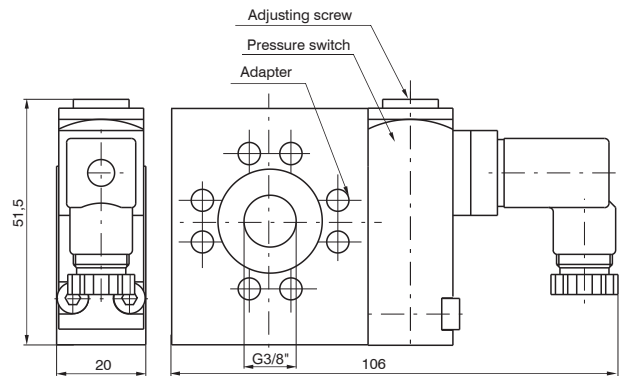

Size 2

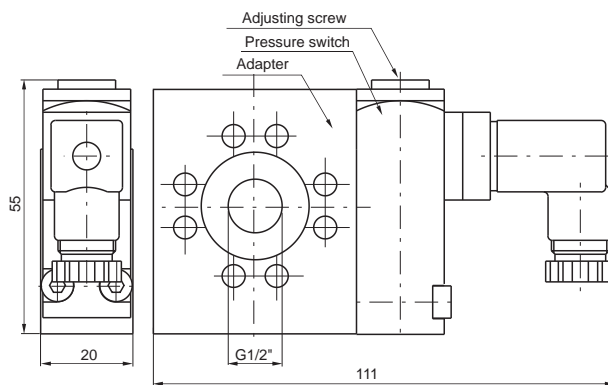

Size 3

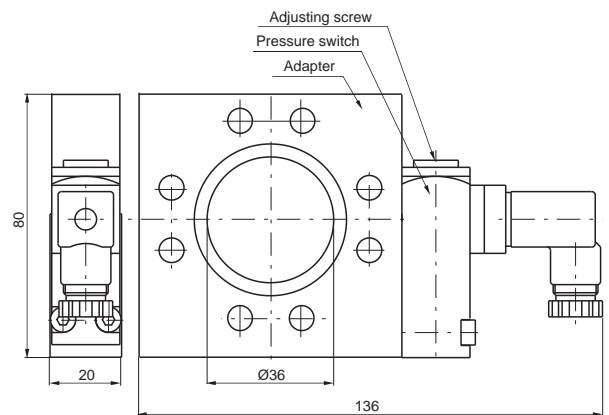

Size 4

**Filter pressure regulator + Lubricator**

- ▶ Filter - diaphragm pressure regulator with relieving
- ▶ Low hysteresis rolling diaphragm and balanced spool
- ▶ Filtering element made of HDPE available in 3 different filtration grades (5µm, 20µm, 50µm)
- ▶ Semi-automatic or automatic drain
- ▶ Available in four pressure ranges up to 12 bar
- ▶ Oil mist lubricator
- ▶ Variable orifice size in function of the flow rate
- ▶ Oil quantity regulation mechanism and oil quantity visualization dome made of polycarbonate (PC)
- ▶ Oil refill plug
- ▶ Available with low level electrical sensor NO and NC
- ▶ Bowls screwed to the body (Size 1)
- ▶ Bowl assembly via bayonet type quick coupling mechanism with safety button (Size 2 - Size 3)
- ▶ Atex certification (II 2GD o II 3GD) on request

**2**
**AIR TREATMENT**

Technical characteristics	Size		
	Size 1	Size 2	Size 3
Body and connections type	Zinc alloy body, Zinc alloy integrated connections Technopolymer body, metal connections	Aluminium body, integrated aluminium connections	
Protection and bowl type	Technopolymer protection - PA bowl (Size 1 available without protection)		
IN / OUT connections	G1/8" - G1/4"	G1/4" - G3/8"	G3/8" - G1/2", G3/4"
Assembly configuration	Stand alone Panel mounted with M4 screws	Stand alone Panel mounted with M5 screws	Stand alone Panel mounted with M6 screws
Assembly position	Vertical ±5°		
Filter pore size (µm)	5 / 20 / 50		
Pressure range (bar)	0 - 2 / 0 - 4 / 0 - 8 / 0 - 12		
Bowl capacity (cm³)	20	30	48
Condensation drain	Semi-automatic Automatic		
Regulation	Manual push and lock with pressure Manual lockable with accessories		
Pressure measurement	G1/8" Pressure gauge connection port		
Bowl capacity (cm³)	36	52	62
Lubrication type	Oil mist		
Min. operational flow at 6,3 bar (NI/min)	10	20	
Oil level regulation	Manual, complete with visual indicator		
Max. fittings torque IN / OUT connections	G1/8" metal: 15 G1/4" metal: 20	G1/4" metal: 20 G3/8" metal: 25	G3/8" metal: 25 G1/2" metal: 30 G3/4" metal: 35

Operational characteristics	Size					
	Size 1	Size 2	Size 3	Size 1	Size 2	Size 3
	Semi-automatic condensation drain			Automatic condensation drain		
Maximum working pressure (bar)	13			10		
Minimum working pressure (bar)	0,5					
Indicative oil drop rate (NI/min)	1 drope every 300/600					
Oil type	FD22 - HG32					
Working temperature (°C)	-5 ÷ +50					



Weights	Size		
	Size 1	Size 2	Size 3
Zinc alloy body version (g)	560	/	/
Technopolymer body version (g)	295	/	/
Aluminium body version (g)	/	750	1100

**Order codes**

17 306A . B . D . S . K

Size, body and connections
006A : Zinc alloy body, connections G1/8" (only for size 1)
006B : Zinc alloy body, connections G1/4" (only for size 1)
106A : Technopolymer body, connections G1/8" (only for size 1)
106B : Technopolymer body, connections G1/4" (only for size 1)
206A : Aluminium body, connections G1/4" (only for size 2)
206B : Aluminium body, connections G3/8" (only for size 2)
306A : Aluminium body, connections G3/8" (only for size 3)
306B : Aluminium body, connections G1/2" (only for size 3)
306E : Aluminium body, connections G3/4" (only for size 3)

Filter pore size
A : 5 µm
B : 20 µm
C : 50 µm

Pressure range
A : 0 - 2 bar
B : 0 - 4 bar
C : 0 - 8 bar
D : 0 - 12 bar

Type
P : Bowl protection (only for size 1)
S : Automatic drain (for all sizes)
PS : Bowl protection and automatic drain (only for size 1)

Options
: Standard
K : Lockable version
U : Lockable version with universal key

**Example: 17306A.B.D.S.K**

Size 3 Filter pressure regulator + Lubricator, aluminium body, G3/8" connections, filter pore size 20 µm 0 - 12 bar, automatic drain lockable version

**Dimensions**

2  
AIR TREATMENT

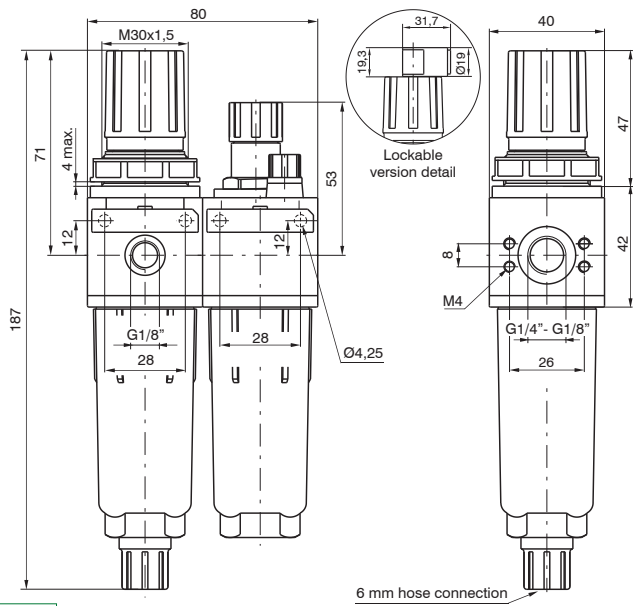

**Size 1**

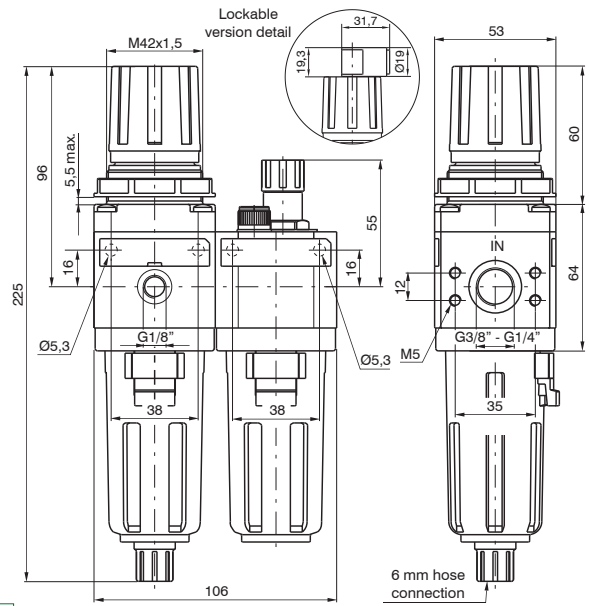

**Size 2**

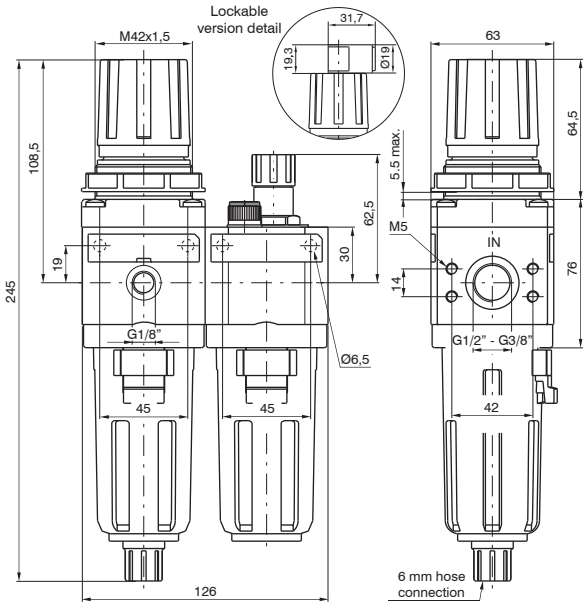

**Size 3**

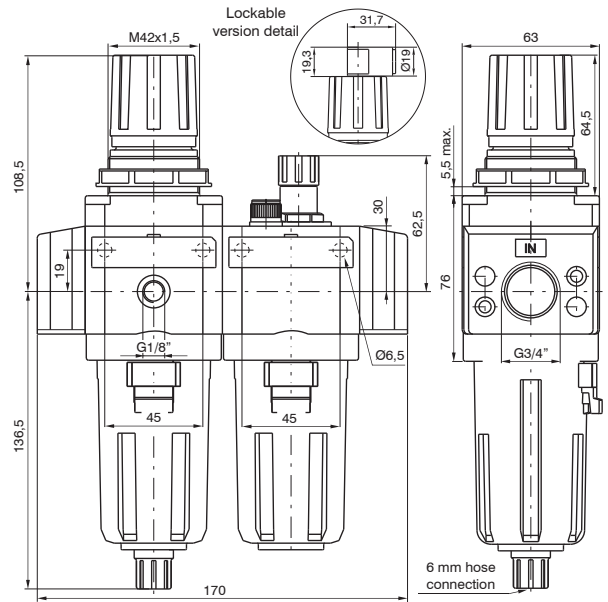

**Size 3 3/4"**



Characteristic curves

Flow rate curves

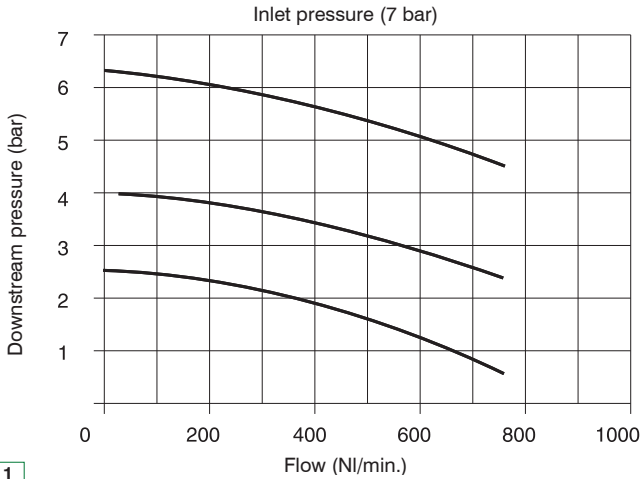

Size 1

Flow rate curves

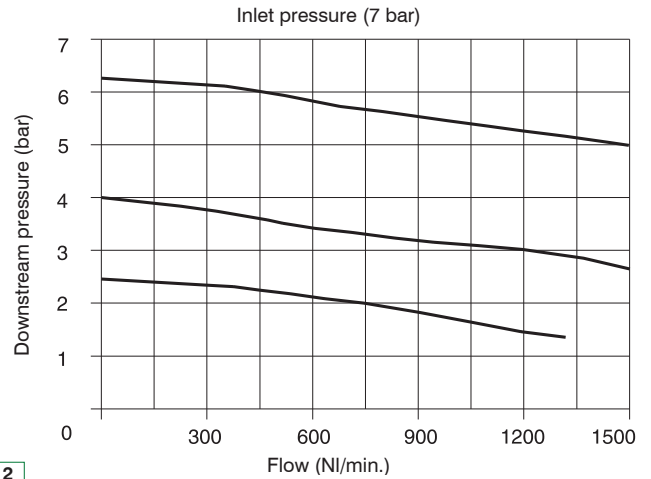

Size 2

Flow rate curves

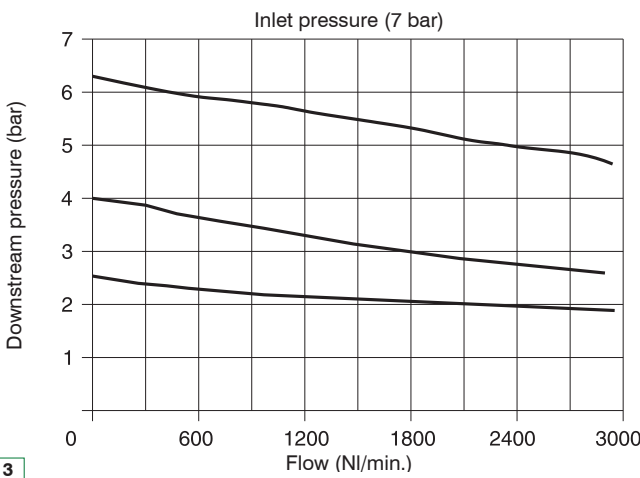

Size 3

Flow rate curves

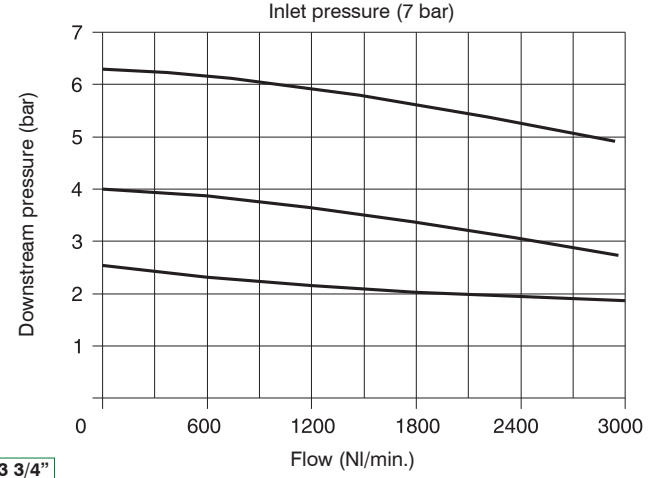

Size 3 3/4"

Adjustment characteristic

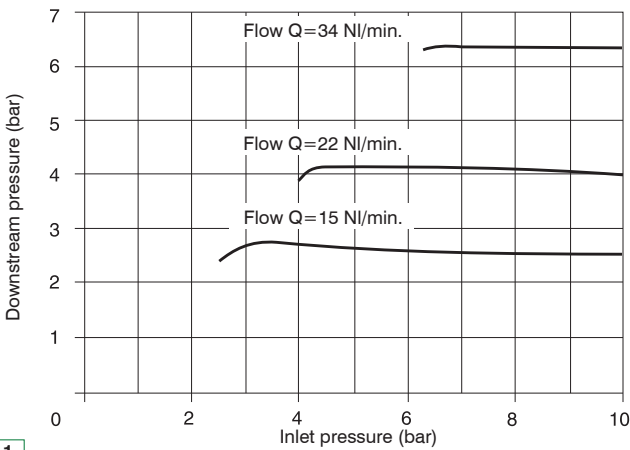

Size 1

Adjustment characteristic

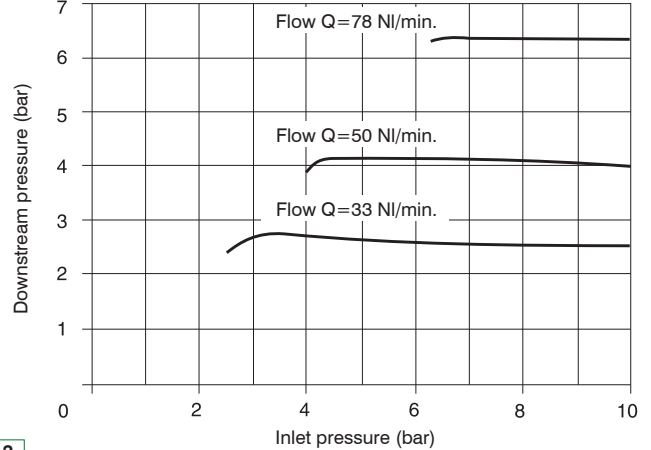

Size 2

Adjustment characteristic

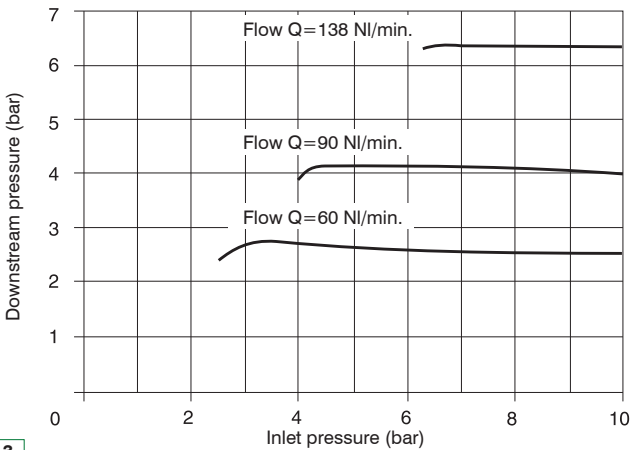

Size 3

Adjustment characteristic

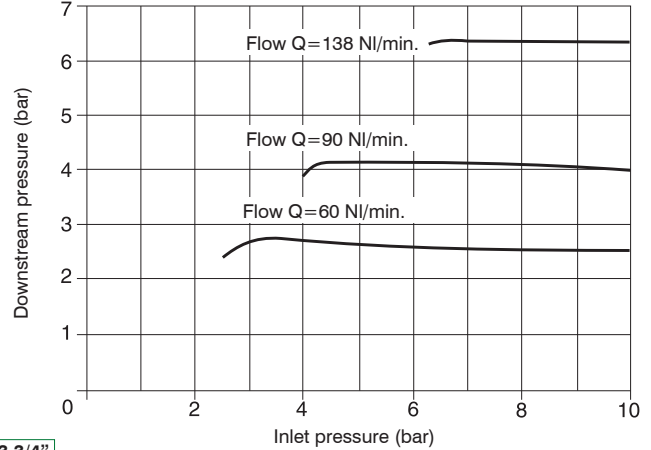

Size 3 3/4"

**Filter + Pressure regulator + Lubricator**

- ▶ Double filter action: air flow centrifugation and filter element
- ▶ Filtering cartridge made of HDPE available in three different filtration grades (5µm, 20µm, 50µm)
- ▶ Filter cartridge can be regenerated by washing / blowing it or replaced
- ▶ Semi-automatic or automatic drain
- ▶ Diaphragm pressure regulator with relieving
- ▶ Low hysteresis rolling diaphragm and balanced spool
- ▶ Available in four pressure ranges up to 12 bar
- ▶ Oil mist lubricator
- ▶ Variable orifice size in function of the flow rate
- ▶ Oil quantity regulation mechanism and oil quantity visualization dome made of polycarbonate (PC)
- ▶ Oil refill plug
- ▶ Available with low level electrical sensor NO and NC
- ▶ Bowls screwed to the body (Size 1)
- ▶ Bowl assembly via bayonet type quick coupling mechanism with safety button (Size 2 - Size 3 - Size 4)
- ▶ Atex certification (II 2GD o II 3GD) on request

**2**
**AIR TREATMENT**

Technical characteristics	Size			
	Size 1	Size 2	Size 3	Size 4
<b>Body and connections type</b>	Zinc alloy body, Zinc alloy integrated connections Technopolymer body, metal connections	Aluminium body, integrated aluminium connections		
<b>Protection and bowl type</b>	Technopolymer protection - PA bowl (Size 1 available without protection)			Metal bowl with blind metal bowl
<b>IN / OUT connections</b>	G1/8" - G1/4"	G1/4" - G3/8"	G3/8" - G1/2", G3/4"	G1"
<b>Assembly configuration</b>	Stand alone Panel mounted with M4 screws	Stand alone Panel mounted with M5 screws	Stand alone Panel mounted with M6 screws	Stand alone Panel mounted with M6 screws
<b>Assembly position</b>	Vertical ±5°			
<b>Filter pore size (µm)</b>	5 / 20 / 50			
<b>Pressure range (bar)</b>	0 - 2 / 0 - 4 / 0 - 8 / 0 - 12			
<b>Bowl capacity (cm³)</b>	20	30	48	178
<b>Condensation drain</b>	Semi-automatic Automatic			
<b>Regulation</b>	Manual push and lock with pressure Manual lockable with accessories			
<b>Pressure measurement</b>	G1/8" Pressure gauge connection port			
<b>Bowl capacity (cm³)</b>	36	52	62	300
<b>Lubrication type</b>	Oil mist			
<b>Min. operational flow at 6,3 bar (NI/min)</b>	10	20		100
<b>Oil level regulation</b>	Manual, complete with visual indicator			
<b>Max. fittings torque IN / OUT connections</b>	G1/8" metal: 15 G1/4" metal: 20	G1/4" metal: 20 G3/8" metal: 25	G3/8" metal: 25 G1/2" metal: 30 G3/4" metal: 35	G1" metal: 35

Operational characteristics	Size							
	Size 1	Size 2	Size 3	Size 4	Size 1	Size 2	Size 3	Size 4
	Semi-automatic condensation drain				Automatic condensation drain			
<b>Maximum working pressure (bar)</b>	13				10			
<b>Minimum working pressure (bar)</b>	0,5							
<b>Indicative oil drop rate (NI/min)</b>	1 drope every 300/600							
<b>Oil type</b>	FD22 - HG32							
<b>Working temperature (°C)</b>	-5 ÷ +50							



Weights	Size			
	Size 1	Size 2	Size 3	Size 4
Zinc alloy body version (g)	755	/	/	/
Technopolymer body version (g)	375	/	/	/
Aluminium body version (g)	/	960	1430	5300

**Order codes**

17 307A . B . D . S . K

Size, body and connections
007A : Zinc alloy body, connections G1/8" (only for size 1)
007B : Zinc alloy body, connections G1/4" (only for size 1)
107A : Technopolymer body, connections G1/8" (only for size 1)
107B : Technopolymer body, connections G1/4" (only for size 1)
207A : Aluminium body, connections G1/4" (only for size 2)
207B : Aluminium body, connections G3/8" (only for size 2)
307A : Aluminium body, connections G3/8" (only for size 3)
307B : Aluminium body, connections G1/2" (only for size 3)
307E : Aluminium body, connections G3/4" (only for size 3)
407NB : Aluminium body, connections G1" (only for size 4)

Filter pore size
A : 5 µm
B : 20 µm
C : 50 µm

Pressure range
A : 0 - 2 bar
B : 0 - 4 bar
C : 0 - 8 bar
D : 0 - 12 bar

Type
P : Bowl protection (only for size 1)
S : Automatic drain (for all sizes)
PS : Bowl protection and automatic drain (only for size 1)

Options
: Standard
K : Lockable version
U : Lockable version with universal key

**Example: 17307A.B.D.S.K**

Size 3 Filter + Pressure regulator + Lubricator, aluminium body, G3/8" connections, filter pore size 20 µm 0 - 12 bar, automatic drain lockable version

**Dimensions**

2  
AIR TREATMENT

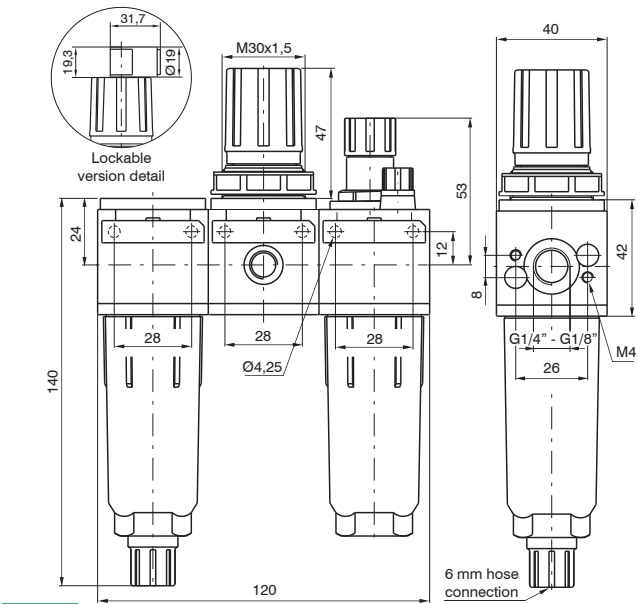

**Size 1**

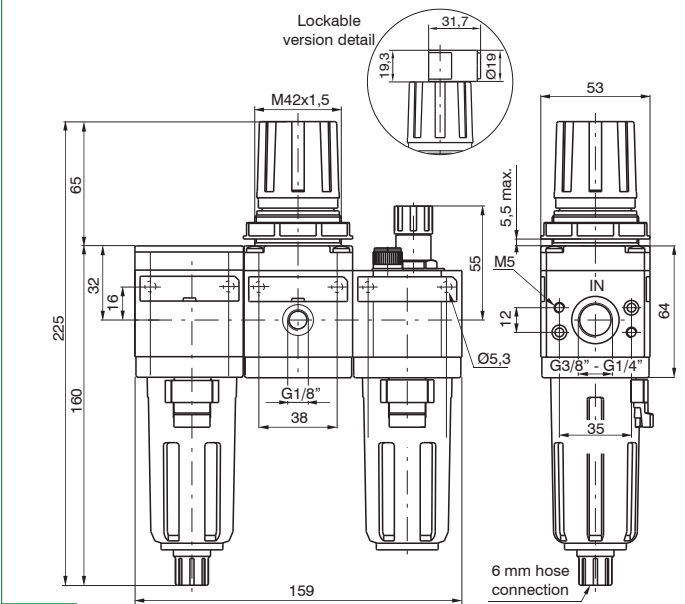

**Size 2**

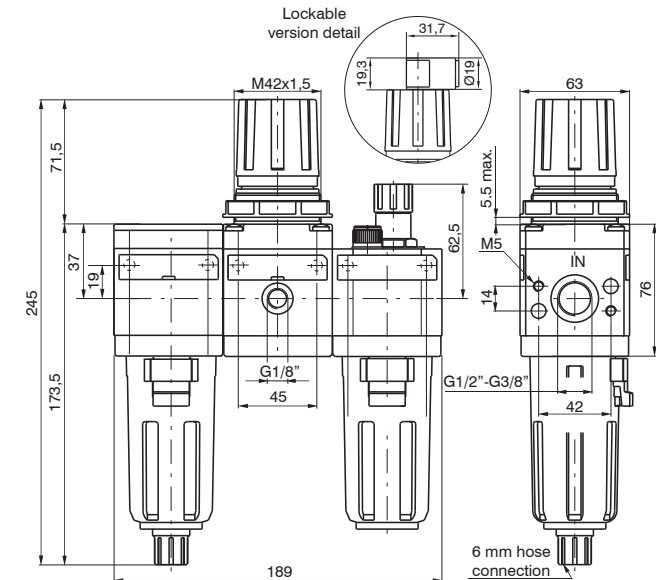

**Size 3**

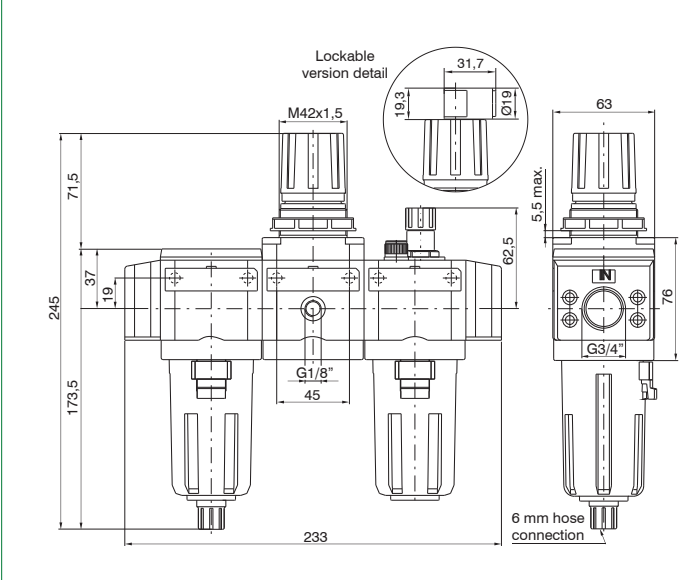

**Size 3 3/4"**

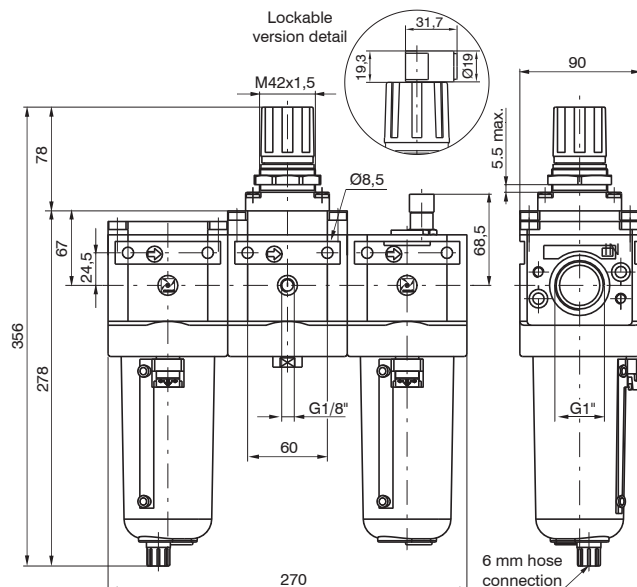

**Size 4**





Characteristic curves

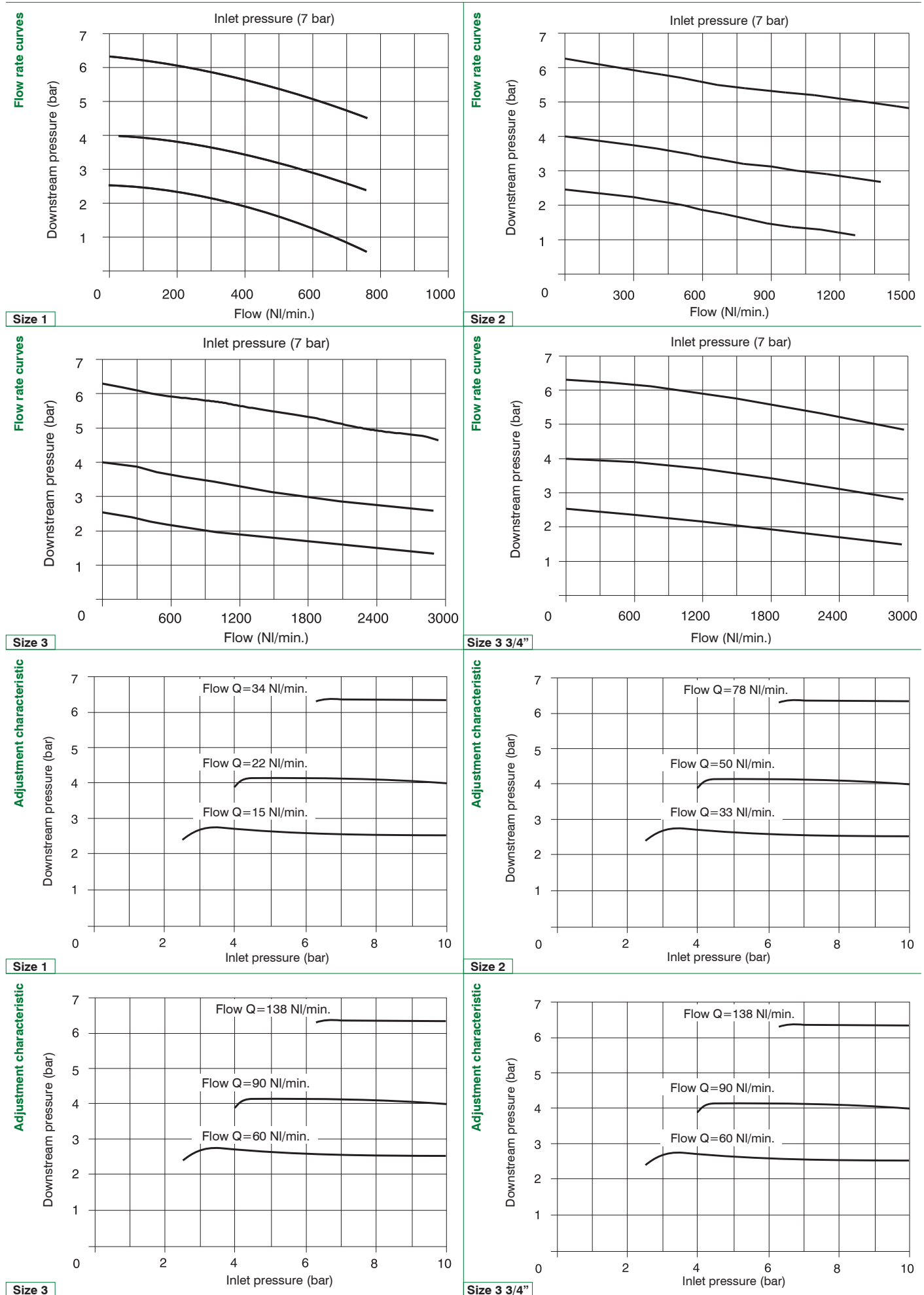

2

AIR TREATMENT

► **Fixing bracket for regulators**

1725 0

Size
1725 : Size 2
1735 : Size 3

Type
0 : For standard regulators
2 : For pressure regulators

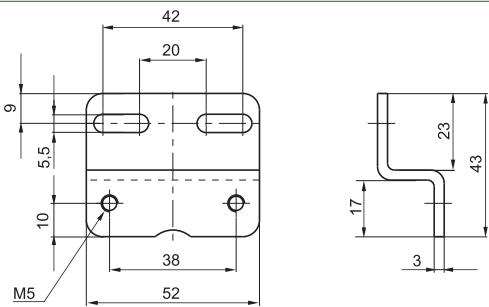

Size 2

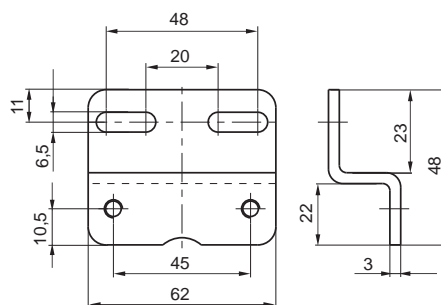

Size 3

► **Fixing bracket**

171 50

Size
171 : Size 1
T172 : Size 2 - Size 3

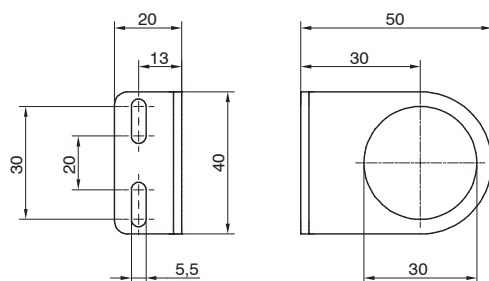

Size 1

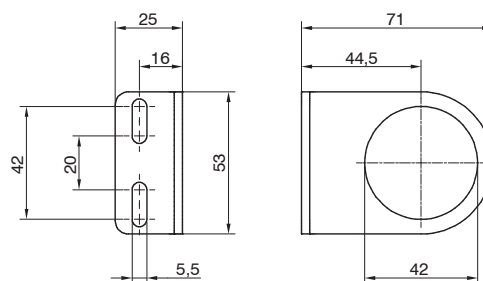

Size 2 - TG3

► **Fixing bracket**

170 M5

Size
170 : Size 1

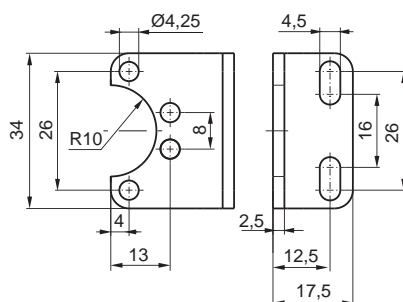

Size 1

2  
AIR TREATMENT

► Fixing bracket for pressure regulator

**Size**  
170 : Size 1

170 50

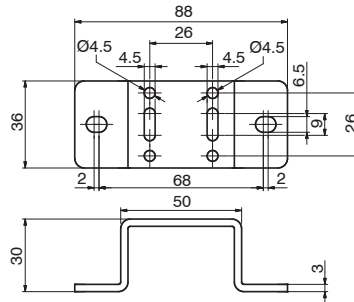

Size 1

► Pressure gauge

**Versione**  
A : Dial Ø40  
B : Dial Ø50

**Scala**  
A : 0 - 4 bar  
B : 0 - 6 bar  
C : 0 - 12 bar

17070 A C

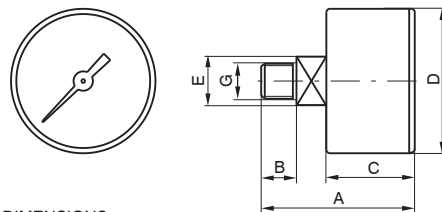

DIMENSIONS

CODE	A	B	C	D	E	G	Weight g
17070A	44	10	26	41	14	1/8"	60
17070B	45	10	27	49	14	1/8"	80

► Pressure gauge diameter Ø23

**Scala**  
A : 0 - 4 bar  
B : 0 - 6 bar  
C : 0 - 12 bar

17070M A

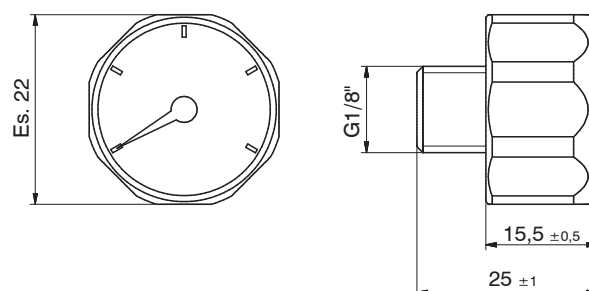



► **Assembling kit**

1726 0

Size
1716 : Size 1
1726 : Size 2
1736 : Size 3
1746 : Size 4

Type
0 : Standard
5 : For progressive start-up valve



2

► **Assembling kit for manifold regulators**

170 M6

Size
170 : Size 1



AIR TREATMENT

► **Flange G3/4"**

1738 1E

Size
1738 : Size 3

Type
1E : Inlet flange
2E : Output flange

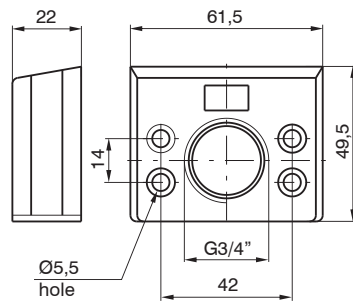

Size 3

## Modular FRL series 1700 Steel line



### General

The stainless steel SS1700 air treatment series has been engineered and developed to approach specifically the OIL & GAS industry and more widely for all the severe service applications that require excellent corrosion resistance due to chemical and/or harsh environmental condition.

**All external and internal parts (except for the automatic drain version) are AISI 316L stainless steel material in compliance with NACE standard MR0175/ISO 15156/1.** The product range includes FILTER, with filtration elements up to 3 filtration degree ( $5\mu\text{m}$ - $20\mu\text{m}$ - $50\mu\text{m}$ ), available in AISI316 stainless steel or HDPE (high density polyethylene), and manual or automatic condensed exhaust; The PRESSURE REGULATOR is supplied with low hysteresis rolling diaphragm and an over-pressure exhaust valve (RELIEVING), available in 4 different adjustment ranges from 0 to 12 bar. As a last the FILTER REGULATOR range, which combines the features of a filter and pressure regulator into a one single device. "CLEAN PROFILE" version is available for all the sizes, featuring a glossy finish on the external surface. The over-pressure exhaust hole (RELIEVING) has a 1/8" NPT threading, and it is protected by an AISI 316 sintered filter series. Note: for CLEAN PROFILE series this is a simple unthread hole.

### Construction and operational characteristics

Body, bowl and adjustment mechanism	AISI 316L stainless steel
Caseback regulator	AISI 316L stainless steel
Adjustment screw, locking nut and fastening screws	AISI 316L stainless steel (stainless steel A4-70)
Internal components	AISI 316L stainless steel
Filtering elements	AISI 316 stainless steel or HDPE (High density polyethylene)
Spring	AISI 316 stainless steel
Seals	

NBR (standard versions and automatic drain)	NBR for low temperatures (L versions)	Silicone - PU (Z version)
FPM - HNBR (H versions)	EPDM-FDA (EF versions)	

Automatic drain	Brass, stainless steel AISI 304 and AISI 302, sintered bronze Acetal resin , NBR, FPM
-----------------	--

### Operating Range

Fluid	Filtered air. No lubrication needed, if applied it shall be continuous. Inert gases. Natural gases
-------	--

Temperature		
-30°C +80°C (standard version)	-5°C +150°C (high temperature H version)	-40°C ÷ +100°C (EPDM-FDA version)
-50°C +80°C (low temperature L version)	-5°C ÷ +70°C (automatic drain S version)	
-60°C +80°C (low temperature version -60 °C Z)	-5°C ÷ +70°C (reduced orifice automatic drain SR version)	

Maximum working pressure		
20 bar (standard, low and high temperature versions)	16 bar (automatic drain version)	10 bar (reduced orifice automatic drain version)

### Instructions for installation and use

Product shall be installed reducing the distance from inlet point. Check and install the device following the flow direction (clearly marked with an arrow stamped on the body). Vertical position installation with condensed exhaust tap pointing downward is recommended.

Devices must be used in compliance with pressure and temperature operating range. To set the pressure there is an adjustable knob, located on the top of the device. Pneumax recommend selection of pressure regulator adjusting range option in line with client required performance. The condensed exhaust action for the manual drain version shall be performed only in the absence of pressure. To discharge liquid, turn the tap clockwise until the discharge of liquid is triggered, then tighten it all the way.

### Maintenance



Filtration elements and filter regulator are reusable through blowing and/or washing and is made of stainless steel or HDPE (high density polyethylene). To replace, remove the cup, loosen the set screw of the support and replace the filter element with a new one or refurbished one. Replace the regulator diaphragm whenever the performance is compromised or if there is a continuous discharge from the relieving hole (over-pressure exhaust). Fully discharge the adjustment spring before removing the adjustment mechanism. For other maintenance activities, due to complexity of assembly and requirement for dedicated PNEUMAX testing activities, it is strongly recommended to contact the manufacturer.

### Certifications available

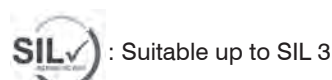

**Filters**

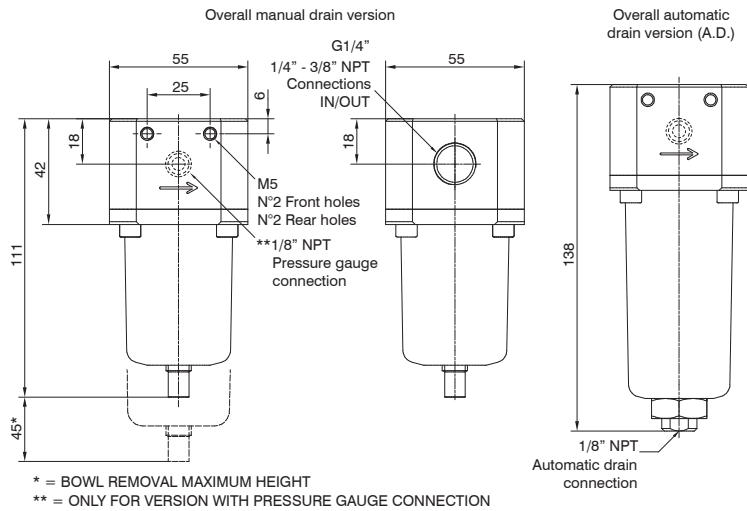

Ordering code	
<b>SV172CF5OZ</b>	
VERSION	
V	S = Standard surface finishing
	F = Clean profile
CONNECTIONS	
G	A = 1/4" NPT
	B = 3/8" NPT
	C = G1/4"
FILTER PORE SIZE	
S	A = 5 μm - 316 stainless steel
	B = 20 μm - 316 stainless steel
	C = 50 μm - 316 stainless steel
	D = 5 μm - HDPE
	E = 20 μm - HDPE
	F = 50 μm - HDPE
OPTIONS	
	= Standard*
	L = Low temperature
	Z = Low temperature (-60 °C)
H	H = High temperature
S	S = Automatic drain
SR	SR = Reduced orifice automatic drain
EF	EF = EPDM-FDA
ENCLOSURE OPTIONS	
Z	= Standard*
G	G = pressure gauge connection
* no additional letter required	

2 AIR SERVICE UNITS

**Construction characteristics**

- Body, bowl and internal components in AISI 316L stainless steel.
- A4 (AISI 316) stainless steel fixing screws.
- Manual or automatic condensed drain

**Technical characteristics**

Maximum inlet pressure (standard version)	20 bar
Maximum inlet pressure (automatic drain version)	16 bar
Maximum inlet pressure (reduced orifice automatic drain version)	10 bar
Temperature (standard version)	-30°C +80°C
Temperature (low temperature version)	-50°C +80°C
Temperature (low temperature version -60°C)	-60°C +80°C
Temperature (high temperature version)	-5°C +150°C
Temperature (automatic and reduced orifice drain version)	-5°C +70°C
Temperature (EPDM-FDA version)	-40°C +100°C
Weight	1070 (gr.)
Bowl capacity	15 cm <sup>3</sup>
Assembly position	Vertical

**Flow rate chart**

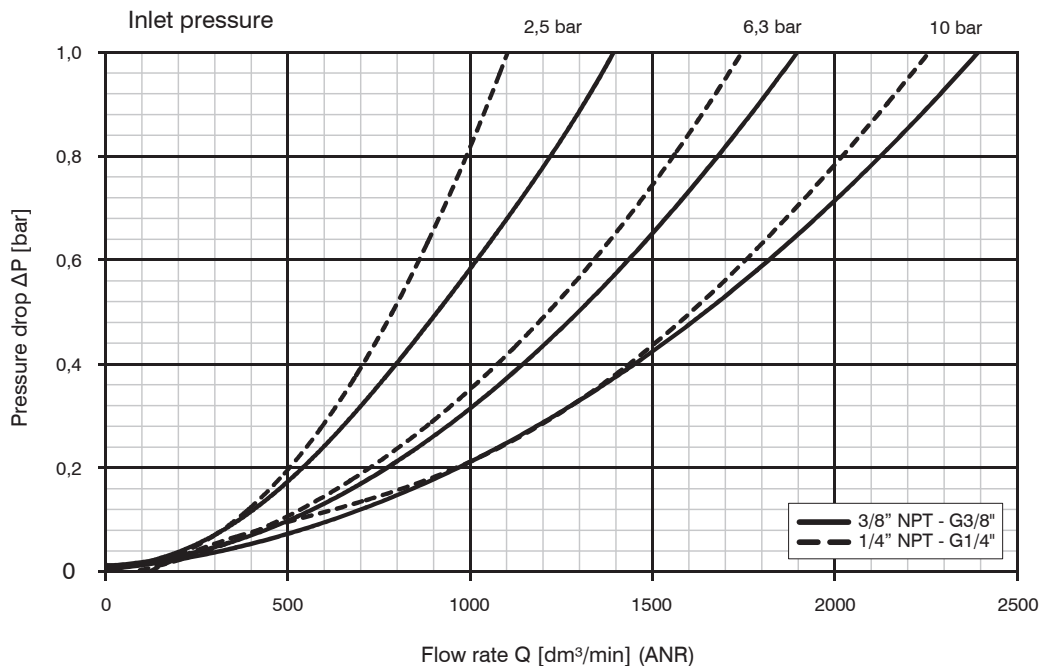



Regulators

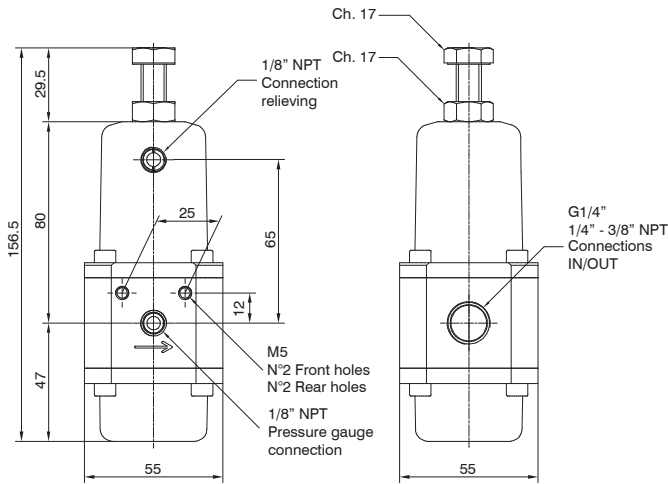

Ordering code	
<b>S01720RG10</b>	
VERSION	
<b>V</b>	S = Standard surface finishing
	F = Clean profile
CONNECTIONS	
<b>C</b>	A = 1/4" NPT
	B = 3/8" NPT
	C = G1/4"
PRESSURE RANGE	
	A = 0-2 bar
<b>G</b>	B = 0-4 bar
	C = 0-8 bar
	D = 0-12 bar
TYPE	
<b>T</b>	= Standard*
	N = Without relieving
OPTIONS	
	= Standard*
<b>O</b>	L = Low temperature
	Z = Low temperature (-60 °C)
	H = High temperature
	EF = EPDM-FDA
* no additional letter required	

2

AIR SERVICE UNITS

Construction characteristics	Technical characteristics																		
<ul style="list-style-type: none"> <li>- Body, adjust. mechanism, AISI 316L stainless steel and caseback inter. components</li> <li>- AISI 316 stainless steel adjustment springs.</li> <li>- Fixing screws, adjustment screws and locknut in A4 (AISI 316) stainless steel.</li> <li>- Pressure regulator diaphragm with over-pressure drain (Relieving).</li> <li>- Low hysteresis rolling diaphragm.</li> <li>- Balanced system.</li> </ul>	<table border="1"> <tr> <td>Maximum inlet pressure (standard version)</td> <td>20 bar</td> </tr> <tr> <td>Temperature (standard version)</td> <td>-30 °C +80 °C</td> </tr> <tr> <td>Temperature (low temperature version)</td> <td>-50 °C +70 °C</td> </tr> <tr> <td>Temperature (low temperature version -60°C)</td> <td>-60 °C +70 °C</td> </tr> <tr> <td>Temperature (high temperature version)</td> <td>-5 °C +150 °C</td> </tr> <tr> <td>Temperature (EPDM-FDA version)</td> <td>-40 °C +100 °C</td> </tr> <tr> <td>Pressure gauge connections</td> <td>1/8" NPT</td> </tr> <tr> <td>Weight</td> <td>1270 (gr.)</td> </tr> <tr> <td>Assembly position</td> <td>Indifferent</td> </tr> </table>	Maximum inlet pressure (standard version)	20 bar	Temperature (standard version)	-30 °C +80 °C	Temperature (low temperature version)	-50 °C +70 °C	Temperature (low temperature version -60°C)	-60 °C +70 °C	Temperature (high temperature version)	-5 °C +150 °C	Temperature (EPDM-FDA version)	-40 °C +100 °C	Pressure gauge connections	1/8" NPT	Weight	1270 (gr.)	Assembly position	Indifferent
Maximum inlet pressure (standard version)	20 bar																		
Temperature (standard version)	-30 °C +80 °C																		
Temperature (low temperature version)	-50 °C +70 °C																		
Temperature (low temperature version -60°C)	-60 °C +70 °C																		
Temperature (high temperature version)	-5 °C +150 °C																		
Temperature (EPDM-FDA version)	-40 °C +100 °C																		
Pressure gauge connections	1/8" NPT																		
Weight	1270 (gr.)																		
Assembly position	Indifferent																		
<p><b>Note</b></p> <p>The pressure must be always regulating while increasing. For a more precise regulation and higher sensibility, the use of a regulator with a pressure range as close as possible to the regulated pressure is recommended.</p>																			

Flow rate chart

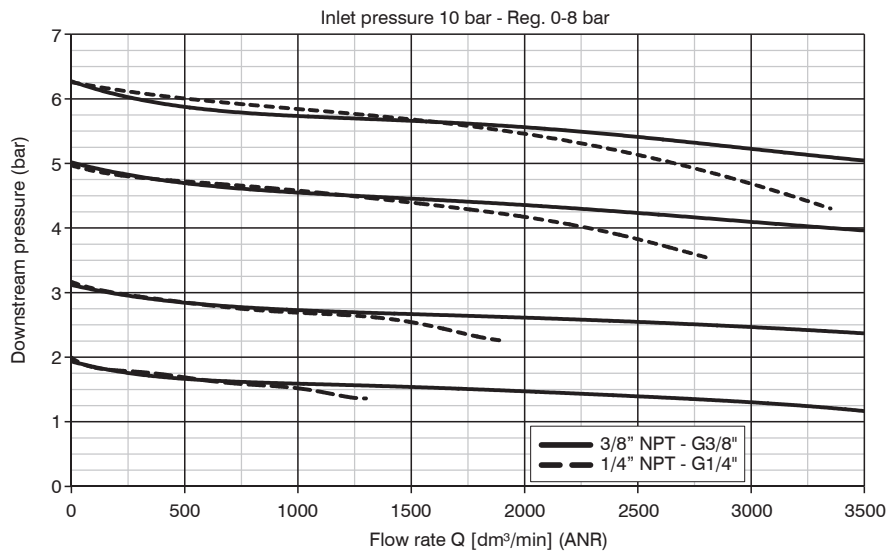

Pressure regulator Stainless steel line have been designed to withstand a **60 Bar** maximum inlet pressure.  
**Maximum regulated outlet pressure is 20 Bar.**  
For performance details please refer to diagram alongside.

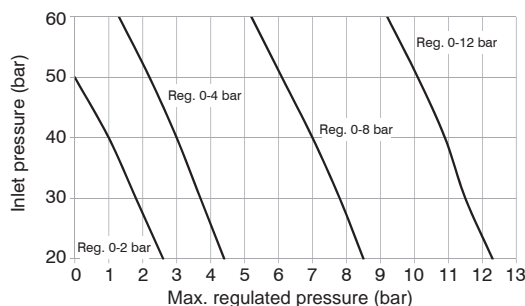

**Filter regulators**

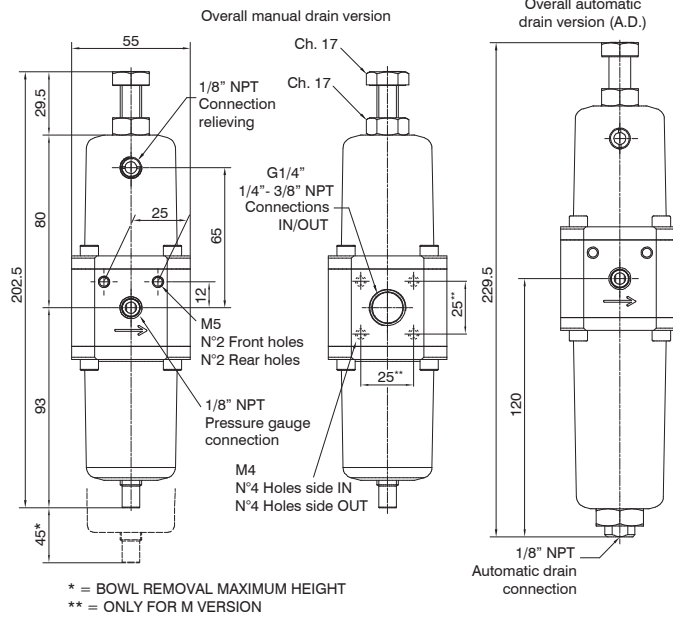

\* = BOWL REMOVAL MAXIMUM HEIGHT  
\*\* = ONLY FOR M VERSION

Ordering code	
<b>SV1720ESG10</b>	
VERSION	
S	Standard surface finishing
V	Clean profile
M	Modular assembly version
CONNECTIONS	
A	1/4" NPT
C	3/8" NPT
C	G1/4"
FILTER PORE SIZE	
A	5 µm - 316 stainless steel
B	20 µm - 316 stainless steel
S	50 µm - 316 stainless steel
D	5 µm - HDPE
E	20 µm - HDPE
F	50 µm - HDPE
PRESSURE RANGE	
A	0-2 bar
G	0-4 bar
C	0-8 bar
D	0-12 bar
TYPE	
T	Standard*
N	Without relieving
OPTIONS	
	Standard*
L	Low temperature
Z	Low temperature (-60 °C)
H	High temperature
S	Automatic drain
SR	Reduced orifice automatic drain
EF	EPDM-FDA
* no additional letter required	

**Construction characteristics**

- Body, adjust. mechanism, AISI 316L stainless steel and caseback inter. components
- AISI 316 stainless steel adjustment springs.
- Fixing screws, adjustment screws and locknut in A4 (AISI 316) stainless steel.
- Filter-pressure regulator diaphragm with over-pressure drain (Relieving).
- Low hysteresis rolling diaphragm.
- Balanced system.
- Manual or automatic condensed drain.

**Technical characteristics**

Maximum inlet pressure (standard version)	20 bar
Maximum inlet pressure (automatic drain version)	16 bar
Maximum inlet pressure (reduced orifice automatic drain version)	10 bar
Temperature (standard version)	-30°C +80°C
Temperature (low temperature version)	-50°C +80°C
Temperature (low temperature version -60°C)	-60°C +80°C
Temperature (high temperature version)	-5°C +150°C
Temperature (automatic and reduced orifice drain version)	-5°C +70°C
Temperature (EPDM-FDA version)	-40°C +100°C
Pressure gauge connections	1/8" NPT
Weight	1470 (gr.)
Bowl capacity	15 cm <sup>3</sup>
Assembly position	Vertical

**Note**

The pressure must be always regulating while increasing. For a more precise regulation and higher sensibility, the use of a regulator with a pressure range as close as possible to the regulated pressure is recommended.

**Flow rate chart**

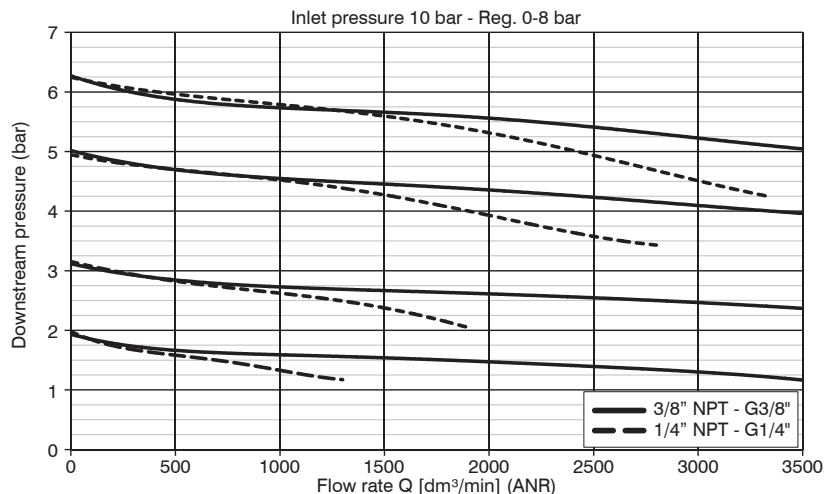

Pressure regulator Stainless steel line have been designed to withstand a **60 Bar** maximum inlet pressure.  
**Maximum regulated outlet pressure is 20 Bar.**  
For performance details please refer to diagram alongside.

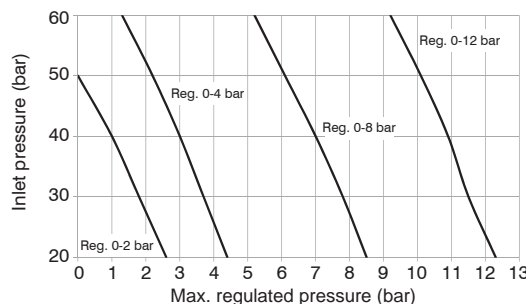



► Fixing bracket

Ordering code
<b>SS17250</b>

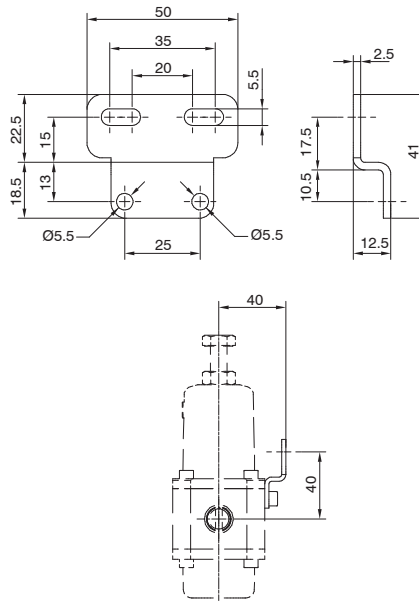

Weight 32 gr.  
AISI 316L stainless steel material.  
Allows wall fixing of individual products.

► Pressure gauge

Ordering code
<b>SS17070A</b>
SCALE
A = 0 - 4 bar
B = 0 - 12 bar

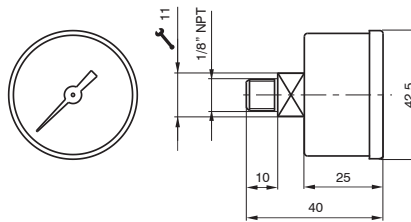

Weight 60 gr.  
AISI 316 stainless steel material.  
Glass transparent part with an AISI 316 stainless steel retaining ring.  
Available with 0-4 bar and 0-12 bar scale.

**Filters**

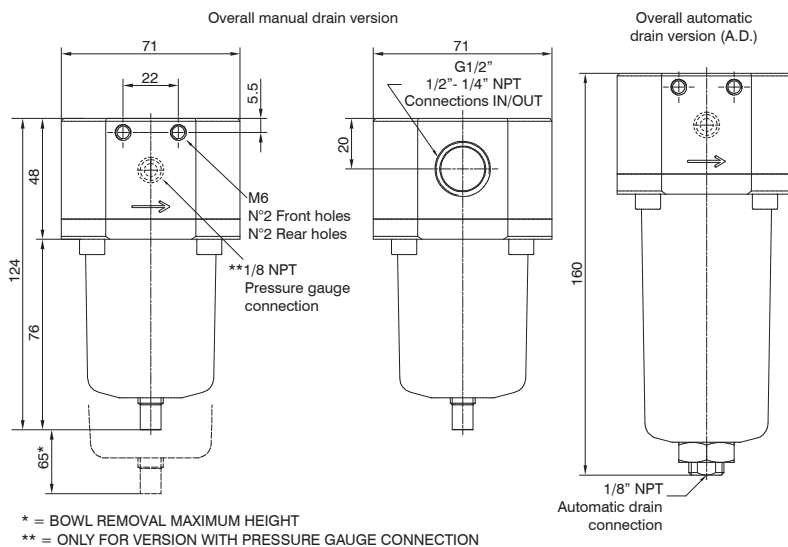

Ordering code	
<b>SV173CF50Z</b>	
VERSION	
V	S = Standard surface finishing
	F = Clean profile
CONNECTIONS	
G	A = 1/4" NPT
	B = 1/2" NPT
	D = G1/2"
FILTER PORE SIZE	
A	A = 5 μm - 316 stainless steel
B	B = 20 μm - 316 stainless steel
S	C = 50 μm - 316 stainless steel
	D = 5 μm - HDPE
	E = 20 μm - HDPE
	F = 50 μm - HDPE
OPTIONS	
	= Standard*
	L = Low temperature
	Z = Low temperature (-60 °C)
O	H = Low temperature
	S = Automatic drain
	SR = Reduced orifice automatic drain
	EF = EPDM-FDA
ENCLOSURE OPTIONS	
Z	= Standard*
	G = pressure gauge connection
* no additional letter required	

2 AIR SERVICE UNITS

**Construction characteristics**

- Body, bowl and internal components in AISI 316L stainless steel.
- A4 (AISI 316) Stainless steel fixing screws.
- Manual or automatic condensed drain.

**Technical characteristics**

Maximum inlet pressure (standard version)	20 bar
Maximum inlet pressure (automatic drain version)	16 bar
Maximum inlet pressure (reduced orifice automatic drain version)	10 bar
Temperature (standard version)	-30°C +80°C
Temperature (low temperature version)	-50°C +80°C
Temperature (low temperature version -60°C)	-60°C +80°C
Temperature (high temperature version)	-5°C +150°C
Temperature (automatic and reduced orifice drain version)	-5°C +70°C
Temperature (EPDM-FDA version)	-40°C +100°C
Weight	1650 (gr.)
Bowl capacity	25 cm <sup>3</sup>
Assembly position	Vertical

**Flow rate chart**

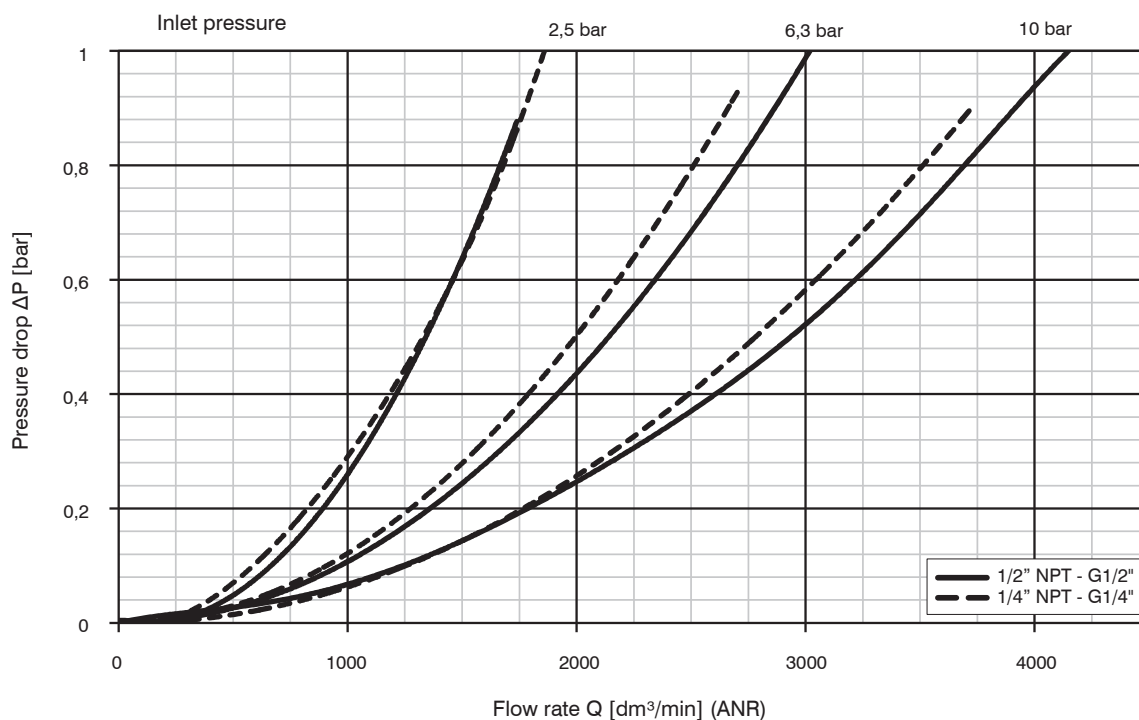



Regulators

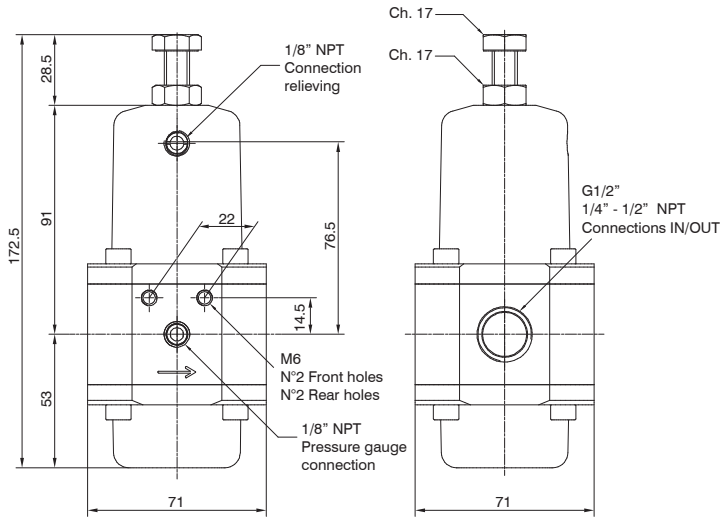

Ordering code	
<b>SV1730RGTO</b>	
VERSION	
V	S = Standard surface finishing
	F = Clean profile
CONNECTIONS	
C	A = 1/4" NPT
	B = 1/2" NPT
	D = G1/2"
PRESSURE RANGE	
	A = 0-2 bar
G	B = 0-4 bar
	C = 0-8 bar
	D = 0-12 bar
TYPE	
T	= Standard*
	N = Without relieving
OPTIONS	
	= Standard*
	L = Low temperature
O	Z = Low temperature (-60 °C)
	H = High temperature
	EF = EPDM-FDA
* no additional letter required	

2 AIR SERVICE UNITS

<p><b>Construction characteristics</b></p> <ul style="list-style-type: none"> <li>- Body, adjust. mechanism, AISI 316L stainless steel and caseback inter. components</li> <li>- AISI 316 stainless steel adjustment springs.</li> <li>- Fixing screws, adjustment screws and locknut in A4 (AISI 316) stainless steel.</li> <li>- Pressure regulator diaphragm with over-pressure drain (Relieving).</li> <li>- Low hysteresis rolling diaphragm.</li> <li>- Balanced system.</li> </ul>	<p><b>Technical characteristics</b></p> <table border="1"> <tr> <td>Maximum inlet pressure (standard version)</td> <td>20 bar</td> </tr> <tr> <td>Temperature (standard version)</td> <td>-30 °C +80 °C</td> </tr> <tr> <td>Temperature (low temperature version)</td> <td>-50 °C +80 °C</td> </tr> <tr> <td>Temperature (low temperature version -60°C)</td> <td>-60 °C +80 °C</td> </tr> <tr> <td>Temperature (high temperature version)</td> <td>-5 °C +150 °C</td> </tr> <tr> <td>Temperature (EPDM-FDA version)</td> <td>-40 °C +100 °C</td> </tr> <tr> <td>Pressure gauge connections</td> <td>1/8" NPT</td> </tr> <tr> <td>Weight</td> <td>1830 (gr.)</td> </tr> <tr> <td>Assembly position</td> <td>Indifferent</td> </tr> </table>	Maximum inlet pressure (standard version)	20 bar	Temperature (standard version)	-30 °C +80 °C	Temperature (low temperature version)	-50 °C +80 °C	Temperature (low temperature version -60°C)	-60 °C +80 °C	Temperature (high temperature version)	-5 °C +150 °C	Temperature (EPDM-FDA version)	-40 °C +100 °C	Pressure gauge connections	1/8" NPT	Weight	1830 (gr.)	Assembly position	Indifferent
Maximum inlet pressure (standard version)	20 bar																		
Temperature (standard version)	-30 °C +80 °C																		
Temperature (low temperature version)	-50 °C +80 °C																		
Temperature (low temperature version -60°C)	-60 °C +80 °C																		
Temperature (high temperature version)	-5 °C +150 °C																		
Temperature (EPDM-FDA version)	-40 °C +100 °C																		
Pressure gauge connections	1/8" NPT																		
Weight	1830 (gr.)																		
Assembly position	Indifferent																		
<p><b>Note</b></p> <p>The pressure must be always regulating while increasing. For a more precise regulation and higher sensibility, the use of a regulator with a pressure range as close as possible to the regulated pressure is recommended.</p>																			

Flow rate chart

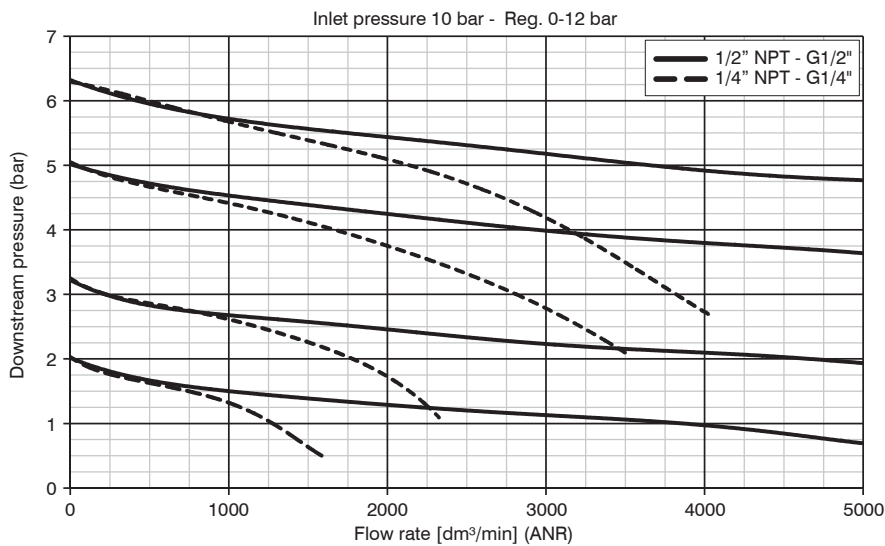

Pressure regulator Stainless steel line have been designed to withstand a **60 Bar** maximum inlet pressure.  
**Maximum regulated outlet pressure is 20 Bar.**  
For performance details please refer to diagram alongside.

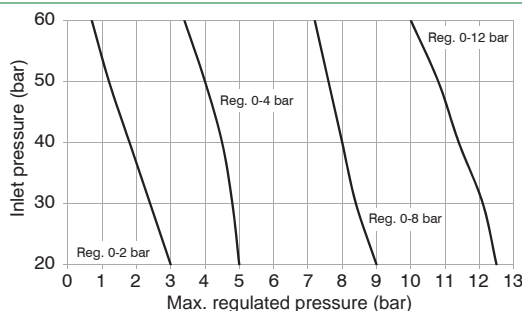

**Filter regulators**

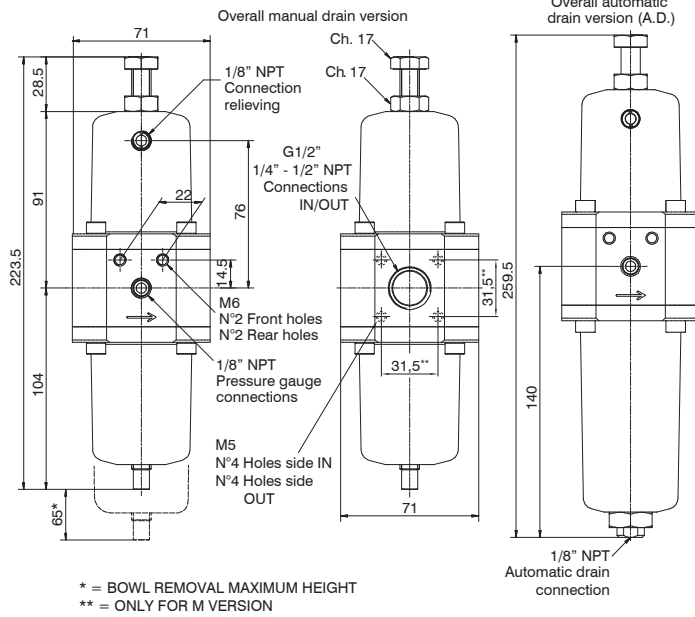

Ordering code	
<b>SV173CESG10</b>	
VERSION	
S	Standard surface finishing
F	Clean profile
M	Modular assembly version
CONNECTIONS	
A	1/4" NPT
B	1/2" NPT
D	G1/2"
FILTER PORE SIZE	
A	5 µm - 316 stainless steel
B	20 µm - 316 stainless steel
C	50 µm - 316 stainless steel
D	5 µm - HDPE
E	20 µm - HDPE
F	50 µm - HDPE
PRESSURE RANGE	
A	0-2 bar
B	0-4 bar
C	0-8 bar
D	0-12 bar
TYPE	
I	Standard*
N	Without relieving
OPTIONS	
	Standard*
L	Low temperature
Z	Low temperature (-60 °C)
H	High temperature
S	Automatic drain
SR	Reduced orifice automatic drain
EF	EPDM-FDA
* no additional letter required	

**Construction characteristics**

- Body, adjust. mechanism, AISI 316L stainless steel and caseback intern. components
- AISI 316 stainless steel adjustment springs.
- Fixing screws, adjustment screws and locknut in A4 (AISI 316) stainless steel.
- Filter-pressure regulator diaphragm with over-pressure drain (Relieving).
- Low hysteresis rolling diaphragm.
- Balanced system.
- Manual or automatic condensed drain.

**Note**

The pressure must be always regulating while increasing. For a more precise regulation and higher sensibility, the use of a regulator with a pressure range as close as possible to the regulated pressure is recommended.

**Technical characteristics**

Maximum inlet pressure (standard version)	20 bar
Maximum inlet pressure (automatic drain version)	16 bar
Maximum inlet pressure (reduced orifice automatic drain version)	10 bar
Temperature (standard version)	-30°C +80°C
Temperature (low temperature version)	-50°C +80°C
Temperature (low temperature version -60°C)	-60°C +80°C
Temperature (high temperature version)	-5°C +150°C
Temperature (automatic and reduced orifice drain version)	-5°C +70°C
Temperature (EPDM-FDA version)	-40°C +100°C
Pressure gauge connections	1/8" NPT
Weight	2110 (gr.)
Bowl capacity	25 cm <sup>3</sup>
Assembly position	Vertical

**Flow rate chart**

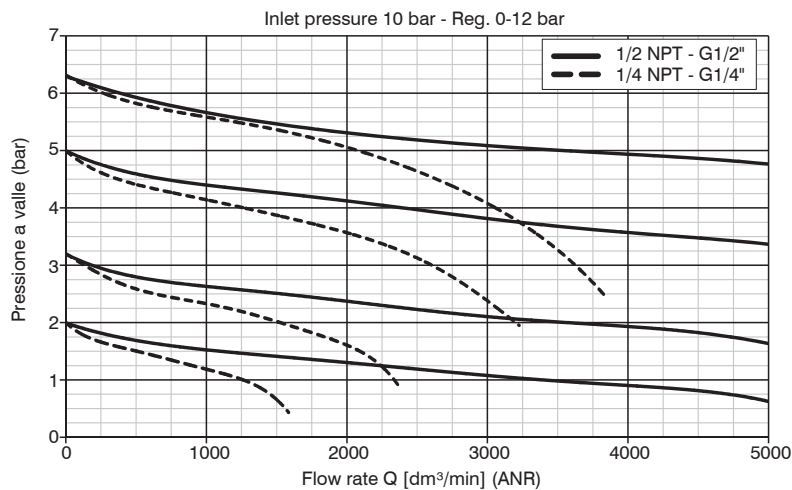

Pressure regulator Stainless steel line have been designed to withstand a **60 Bar** maximum inlet pressure.  
**Maximum regulated outlet pressure is 20 Bar.**  
For performance details please refer to diagram alongside.

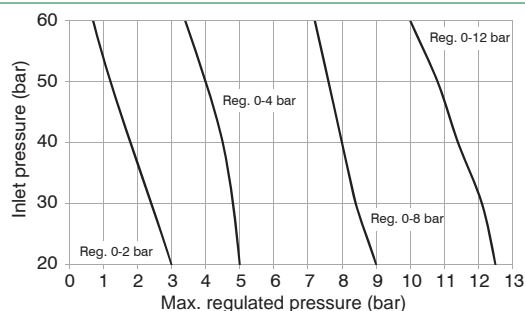

► Fixing bracket

Ordering code
<b>SS17350</b>

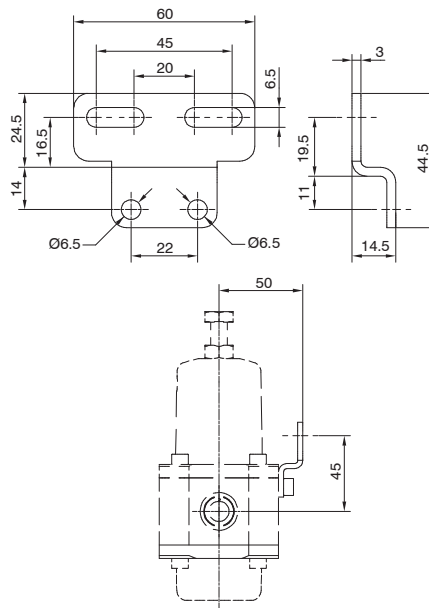

Weight 32 gr.  
AISI 316L stainless steel material.  
Allows wall fixing of individual products.

► Pressure gauge

Ordering code
<b>SS17070A</b>
SCALE
A = 0 - 4 bar
B = 0 - 12 bar

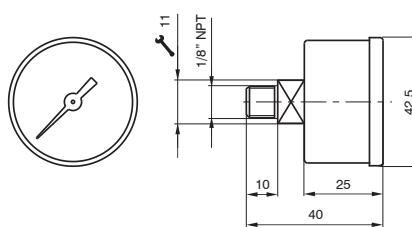

Weight 60 gr.  
AISI 316 stainless steel material.  
Glass transparent part with an AISI 316 stainless steel retaining ring.  
Available with 0-4 bar and 0-12 bar scale.

**Filters**

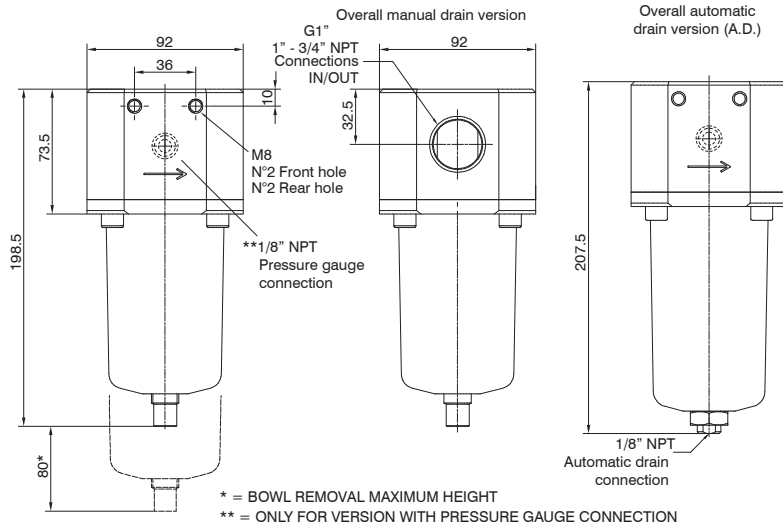

Ordering code	
<b>SV174CF50Z</b>	
VERSION	
V	S = Standard surface finishing
	F = Clean profile
CONNECTIONS	
G	A = 3/4" NPT
	B = 1" NPT
	D = G1"
FILTER PORE SIZE	
A	A = 5 µm - 316 stainless steel
B	B = 20 µm - 316 stainless steel
S	C = 50 µm - 316 stainless steel
	D = 5 µm - HDPE
	E = 20 µm - HDPE
	F = 50 µm - HDPE
OPTIONS	
	= Standard*
L	L = Low temperature
Z	Z = Low temperature (-60 °C)
H	H = High temperature
S	S = Automatic drain
SR	SR = Reduced orifice automatic drain
EF = EPDM-FDA	
ENCLOSURE OPTIONS	
	= Standard*
Z	G = pressure gauge connection
* no additional letter required	

2 AIR SERVICE UNITS

**Construction characteristics**

- Body, bowl and internal components in AISI 316L stainless steel.
- A4 (AISI 316) stainless steel fixing screws.
- Manual or automatic condensed drain.

**Technical characteristics**

Maximum inlet pressure (standard version)	20 bar
Maximum inlet pressure (automatic drain version)	16 bar
Maximum inlet pressure (reduced orifice automatic drain version)	10 bar
Temperature (standard version)	-30°C +80°C
Temperature (low temperature version)	-50°C +80°C
Temperature (low temperature version -60°C)	-60°C +80°C
Temperature (high temperature version)	-5°C +150°C
Temperature (automatic and reduced orifice drain version)	-5°C +70°C
Temperature (EPDM-FDA version)	-40°C +100°C
Weight 3/4 NPT - G 3/4"	4700 (gr.)
Weight 1 NPT - G 1"	4600 (gr.)
Bowl capacity	78 cm <sup>3</sup>
Assembly position	Vertical

**Flow rate chart**

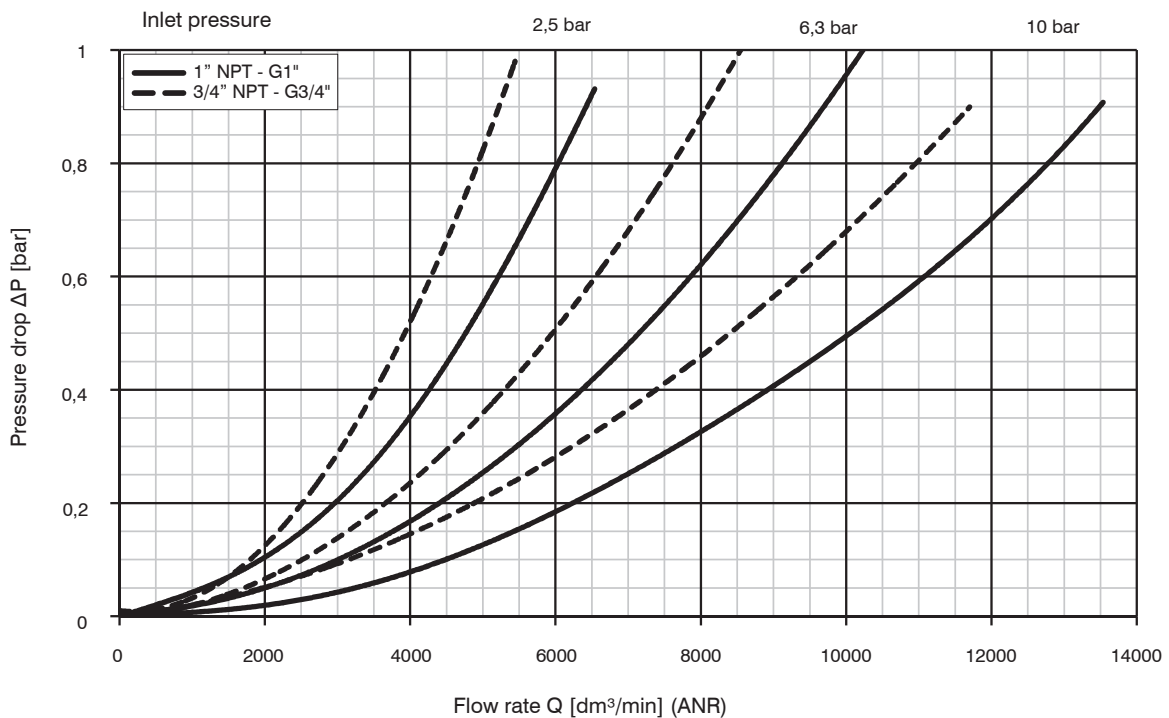



Regulators

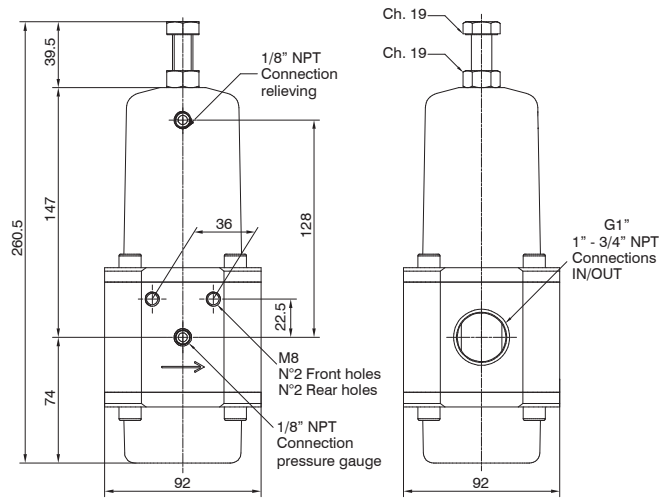

Ordering code	
<b>SV174GRGTO</b>	
VERSION	
V	S = Standard surface finishing
	F = Clean profile
CONNECTIONS	
C	A = 3/4" NPT
	B = 1" NPT
	D = G1"
PRESSURE RANGE	
	A = 0-2 bar
G	B = 0-4 bar
	C = 0-7 bar
	D = 0-10 bar
TYPE	
T	= Standard*
	N = Without relieving
OPTIONS	
	= Standard*
O	L = Low temperature
	Z = Low temperature (-60 °C)
	H = High temperature
	EF = EPDM-FDA
* no additional letter required	

Construction characteristics

- Body, adjust. mechanism, AISI 316L stainless steel and caseback inter. components
- AISI 316 Adjustment springs.
- Fixing screws, adjustment screws and locknut in A4 (AISI 316) stainless steel.
- Pressure regulator diaphragm with over-pressure drain (Relieving).
- Low hysteresis rolling diaphragm.
- Balanced system.

Note

The pressure must be always regulating while increasing. For a more precise regulation and higher sensibility, the use of a regulator with a pressure range as close as possible to the regulated pressure is recommended.

Technical characteristics

Maximum inlet pressure (standard version)	20 bar
Temperature (standard version)	-30 °C +80 °C
Temperature (low temperature version)	-50 °C +80 °C
Temperature (low temperature version -60°C)	-60 °C +80 °C
Temperature (high temperature version)	-5 °C +150 °C
Temperature (EPDM-FDA version)	-40 °C +100 °C
Pressure gauge connections	1/8" NPT
Weight 3/4" NPT - G3/4"	5500 (gr.)
Weight 1" NPT - G1"	5400 (gr.)
Assembly position	Indifferent

Flow rate chart

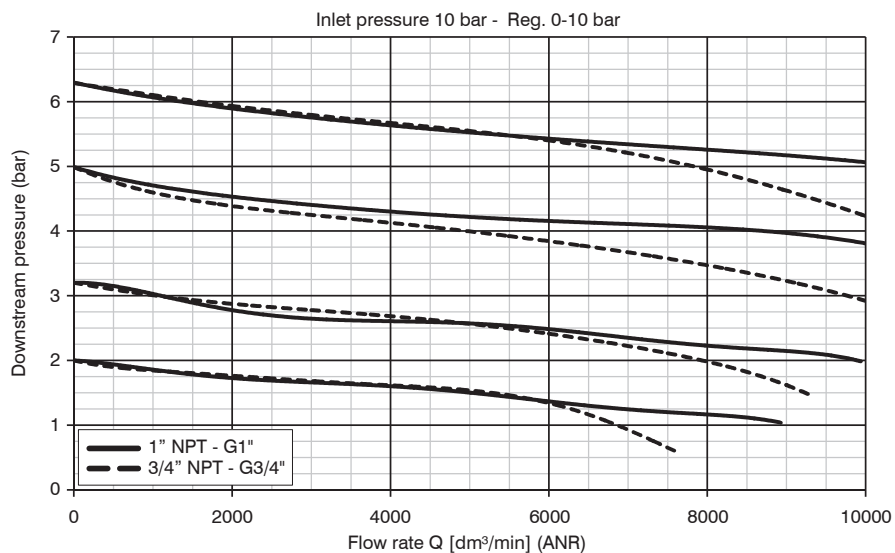

Pressure regulator Stainless steel line have been designed to withstand a **60 Bar** maximum inlet pressure.  
**Maximum regulated outlet pressure is 20 Bar.**  
For performance details please refer to diagram alongside.

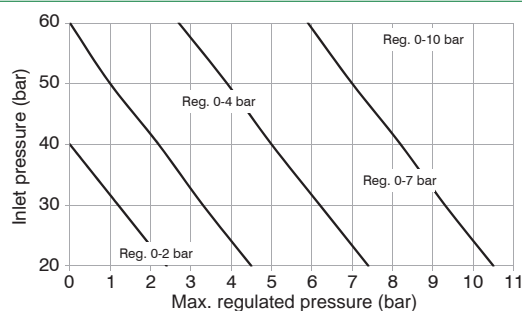

**Filter regulators**

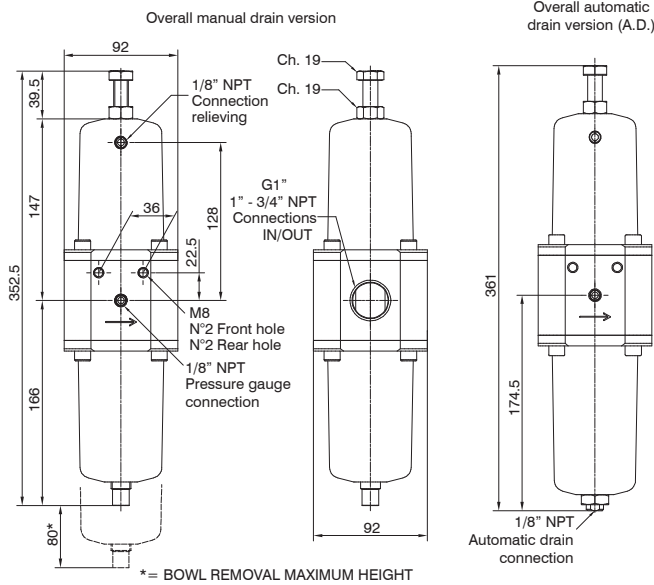

Ordering code	
<b>SV174CESGT0</b>	
VERSION	
V	S = Standard surface finishing
	F = Clean profile
CONNECTIONS	
C	A = 3/4" NPT
	B = 1" NPT
	D = G1"
FILTER PORE SIZE	
	A = 5 μm - 316 stainless steel
	B = 20 μm - 316 stainless steel
S	C = 50 μm - 316 stainless steel
	D = 5 μm - HDPE
	E = 20 μm - HDPE
	F = 50 μm - HDPE
PRESSURE RANGE	
	A = 0-2 bar
G	B = 0-4 bar
	C = 0-7 bar
	D = 0-10 bar
TYPE	
T	= Standard*
	N = Without relieving
OPTIONS	
	= Standard*
	L = Low temperature
	Z = Low temperature (-60 °C)
O	H = High temperature
	S = Automatic drain
	SR = Reduced orifice automatic drain
	EF = EPDM-FDA
* no additional letter required	

2 AIR SERVICE UNITS

**Construction characteristics**

- Body, adjust. mechanism, AISI 316L stainless steel and caseback inter. components
- AISI 316 stainless steel adjustment springs.
- Fixing screws, adjustment screws and locknut in A4 (AISI 316) stainless steel.
- Filter-pressure regulator diaphragm with over-pressure drain (Relieving).
- Low hysteresis rolling diaphragm.
- Balanced system.
- Manual or automatic condensed drain.

**Technical characteristics**

Maximum inlet pressure (standard version)	20 bar
Maximum inlet pressure (automatic drain version)	16 bar
Maximum inlet pressure (reduced orifice automatic drain version)	10 bar
Temperature (standard version)	-30°C + 80°C
Temperature (low temperature version)	-50°C + 80°C
Temperature (low temperature version -60°C)	-60°C + 80°C
Temperature (high temperature version)	-5°C + 150°C
Temperature (automatic and reduced orifice drain version)	-5°C + 70°C
Temperature (EPDM-FDA version)	-40°C + 100°C
Pressure gauge connections	1/8" NPT
Weight 3/4" NPT - G3/4"	6300 (gr.)
Weight 1" NPT - G1"	6200 (gr.)
Bowl capacity	78 cm <sup>3</sup>
Assembly position	Vertical

**Note**

The pressure must be always regulating while increasing. For a more precise regulation and higher sensibility, the use of a regulator with a pressure range as close as possible to the regulated pressure is recommended.

**Flow rate chart**

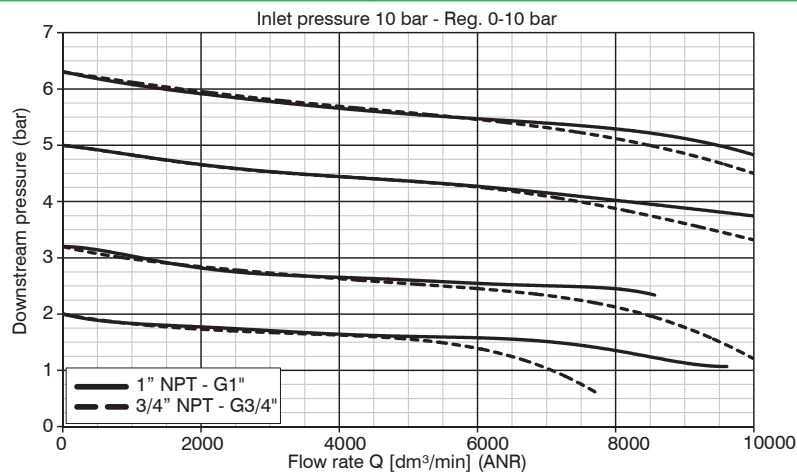

Pressure regulator Stainless steel line have been designed to withstand a **60 Bar** maximum inlet pressure.  
**Maximum regulated outlet pressure is 20 Bar.**  
For performance details please refer to diagram alongside.

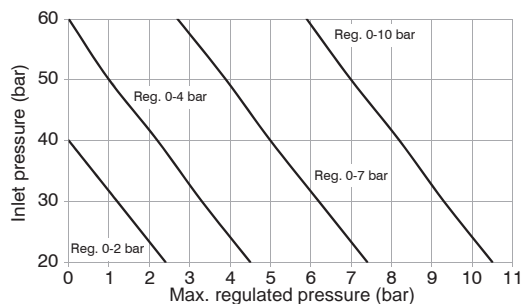



► Fixing bracket

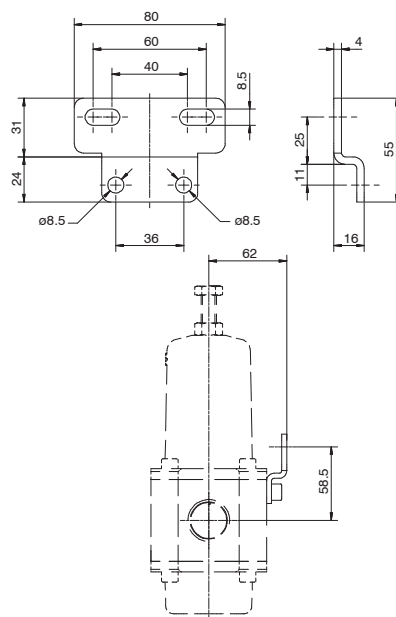

Ordering code
<b>SS17450</b>

Weight 32 gr.  
AISI 316L stainless steel material.  
Allows wall fixing of individual products.

► Pressure gauge

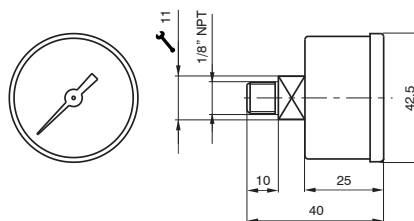

Ordering code
<b>SS17070A</b>
SCALE
A = 0 - 4 bar
B = 0 - 12 bar

Weight 60 gr.  
AISI 316 stainless steel material.  
Glass transparent part with an AISI 316 stainless steel retaining ring.  
Available with 0-4 bar and 0-12 bar scale.



## Series 1700 - Electronic proportional regulators

### General

Modern industrial applications require increasingly high performances from their pneumatic components. For example, the speed and thrust of a pneumatic actuator may need to be varied. These parameters often need to be modified dynamically while an operation is running.

This solution can be achieved by means of a regulator that can vary pressure over time.

Pneumax portfolio includes 1700 Series electronic proportional regulator, available in three different sizes with flow rates of 7, 1100, and 4000 NI/min respectively and supporting Analog/Digital, CANopen® or IO-Link communication interfaces.

### Application fields

Typical applications will include the necessity to dynamically control the force of the actuator, be it thrust or torque.

Examples include: Closing systems, painting systems, tensioning systems, packaging systems, pneumatic braking systems, force control for welding grippers, thickness compensation systems, balancing systems, laser cutting, pressure transducers for the control of modulating valves, test benches for system testing, force control for buffers on polishers, etc.

### Product presentation

The supply and exhaust connections are on one side of the regulator and the working port is on the opposite side. The two remaining sides carry G 1/8" ports that are blanked off with removable plugs, these can be used to connect a pressure gauge or as an outlet port. If you order the version with the external feedback there is a M5 threaded connection to which connect the feedback pressure (to the pressure transducer). This connection is placed on the outlet connection side. This option allows to take the signal from a remote point instead of directly from the outlet connection; this function is typically used when the regulated pressure is used far away from the regulator. The control solenoid valves, the pressure sensor, and the management electronics are placed in upper part of the regulator. The electronic management system is the same for all the size 0, size 1 and size 3 regulators.

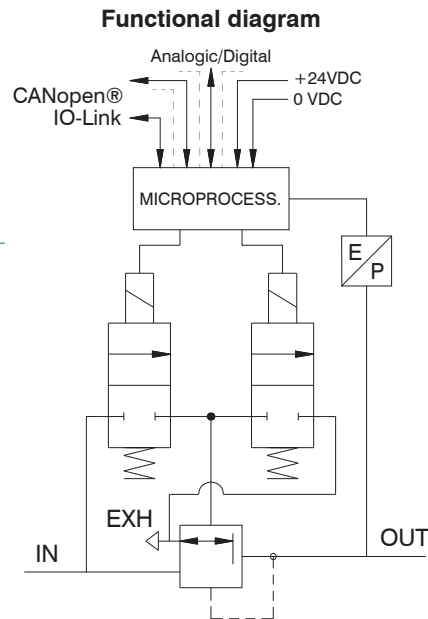

### CLOSED LOOP diagram (internal control circuit)

The proportional regulator is known as a CLOSED LOOP regulator because a pressure transducer in the circuit transmits a continuous analog signal to the microprocessor, which compares the reference value and supplies the control solenoid valves accordingly.

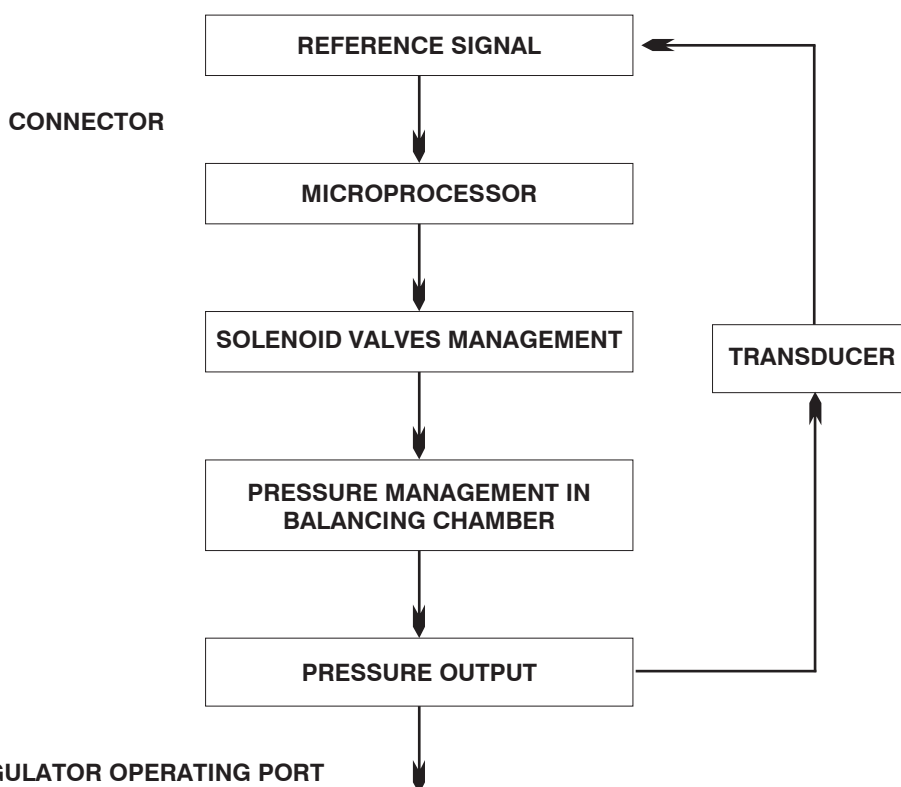

2 AIR SERVICE UNITS



## Features

### Pneumatic

Fluid	Air filtered at 5 micron and dehumidified		
Minimum inlet pressure	Desired outlet pressure + 1 bar		
Maximum inlet pressure	10 bar		
Outlet pressure	0 ÷ 9 bar		
Nominal flowrate from 1 to 2 (6 bar ΔP 1 bar)	<b>Size 0</b>	<b>Size 1</b>	<b>Size 3</b>
	7 NI/min	1100 NI/min	4000 NI/min
Discharge flowrate (a 6 bar with 1 bar overpressure)	7 NI/min	1300 NI/min	4500 NI/min
Air consumption	< 1 NI/min	< 1 NI/min	< 1 NI/min
Supply connection	M5	G 1/4"	G 1/2"
Operating connection	M5	G 1/4"	G 1/2"
Exhaust connection	Ø1,8	G 1/8"	G 3/8"
Maximum fitting tightening	3 Nm	15 Nm	15 Nm

### Electric

Supply voltage	24VDC ± 10% (stabilized with ripple < 1%)	
Standby current consumption	70mA	
Current consumption with solenoid valves on	400mA	
**Reference Signal	Voltage	*0 ÷ 10 V *0 ÷ 5 V *1 ÷ 5 V
	Current	*4 ÷ 20 mA *0 ÷ 20 mA
**Input Impedance	Voltage	10 kΩ
	Current	250 Ω
**Digital Inputs	24VDC ± 10%	
**Digital Output	24 VDC PNP (max current 50 mA)	

### Functional

Linearity	± Insensitivity
Hysteresis	± Insensitivity
Repeatability	± Insensitivity
Sensitivity	0,01 bar
Assembly position	Indifferent
Protection grade	IP65 (with casing fitted)
Ambient temperature	-5° ÷ 50° / 23°F ÷ 122°F

### Constructional

Body	Anodized aluminum		
Shutters	Brass with vulcanized NBR		
Diaphragm	Cloth-covered rubber		
Seals	NBR		
Cover for electrical part	Technopolymer		
Springs	AISI 302		
Weight	<b>Size 0</b>	<b>Size 1</b>	<b>Size 3</b>
	168 gr.	360 gr.	850 gr.

\* Selectable by keyboard or by RS-232

\*\* Valid only for devices with analog input



Overall dimensions ("521" standard version and CANopen® version with SUB-D 15 poles)

Size 0

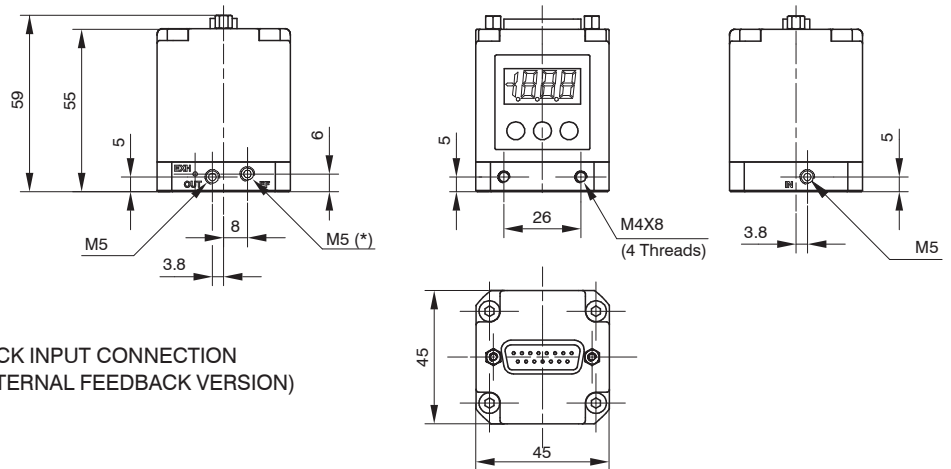

\* = EXTERNAL FEEDBACK INPUT CONNECTION  
(AVAILABLE ONLY ON THE EXTERNAL FEEDBACK VERSION)

Size 1

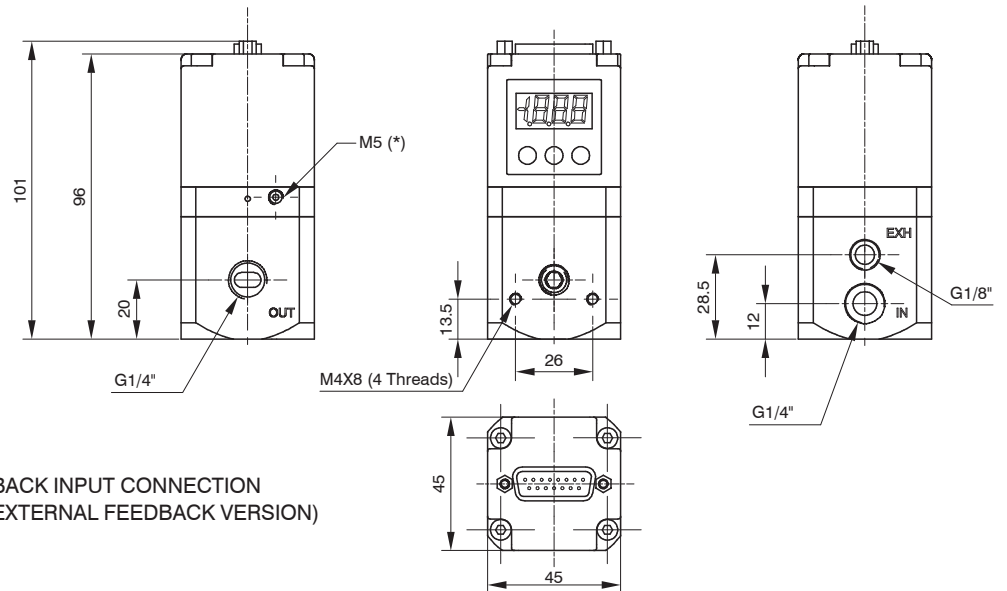

\* = EXTERNAL FEEDBACK INPUT CONNECTION  
(AVAILABLE ONLY ON THE EXTERNAL FEEDBACK VERSION)

Size 3

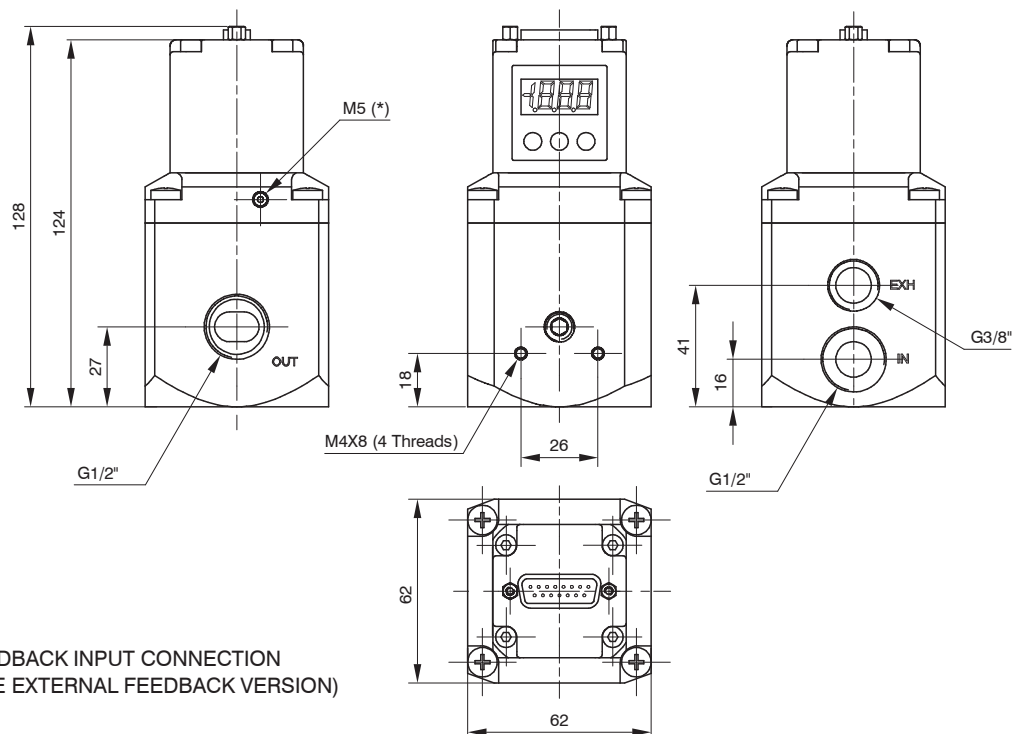

\* = EXTERNAL FEEDBACK INPUT CONNECTION  
(AVAILABLE ONLY ON THE EXTERNAL FEEDBACK VERSION)

2 AIR SERVICE UNITS

**Mounting options ("521" standard version and CANopen® version with SUB-D 15 poles)**

In addition to mounting directly using the M4 tappings on the body, the 170M5 bracket may also be used, as shown below:

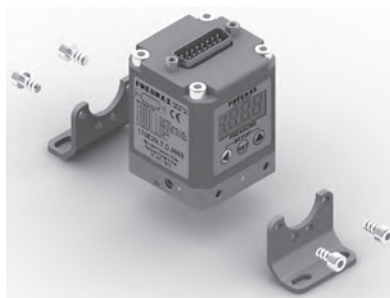
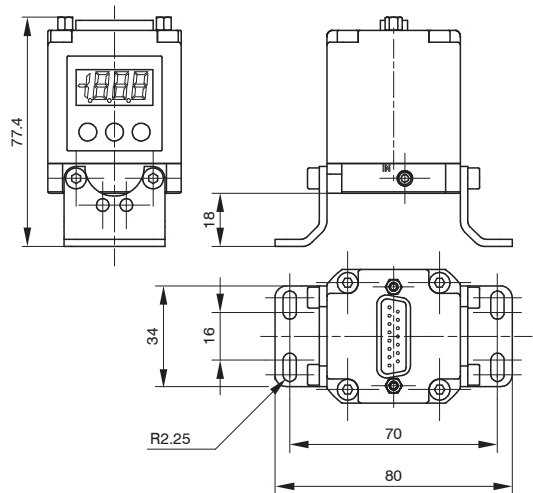

Size 0

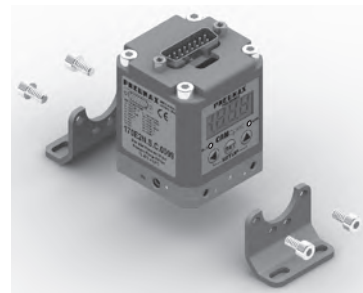

Size 1

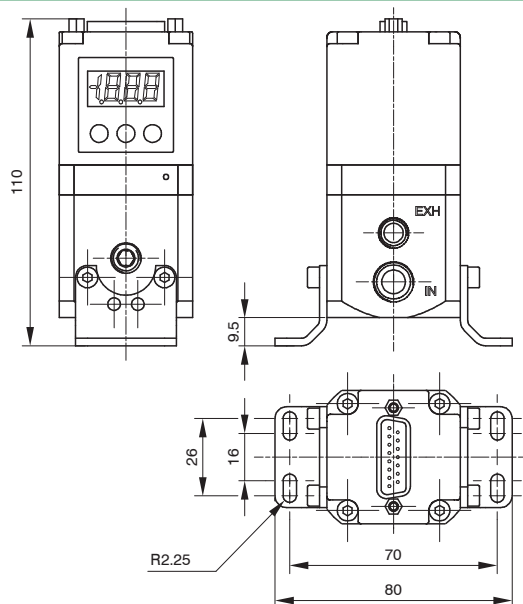

Size 3

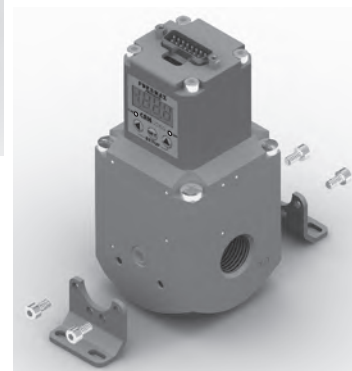
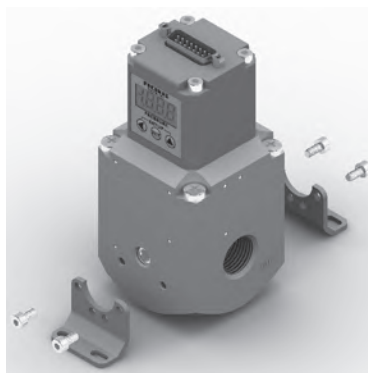
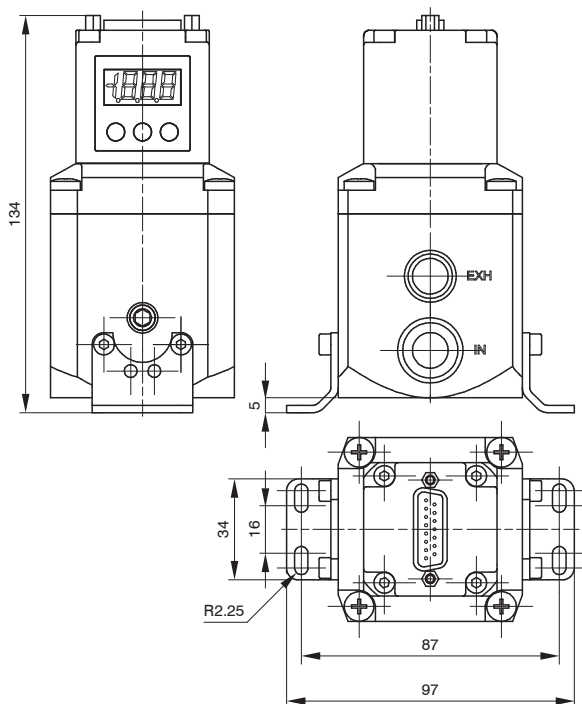

Overall dimensions ("521 M12 version" - CANopen® version)

Size 0

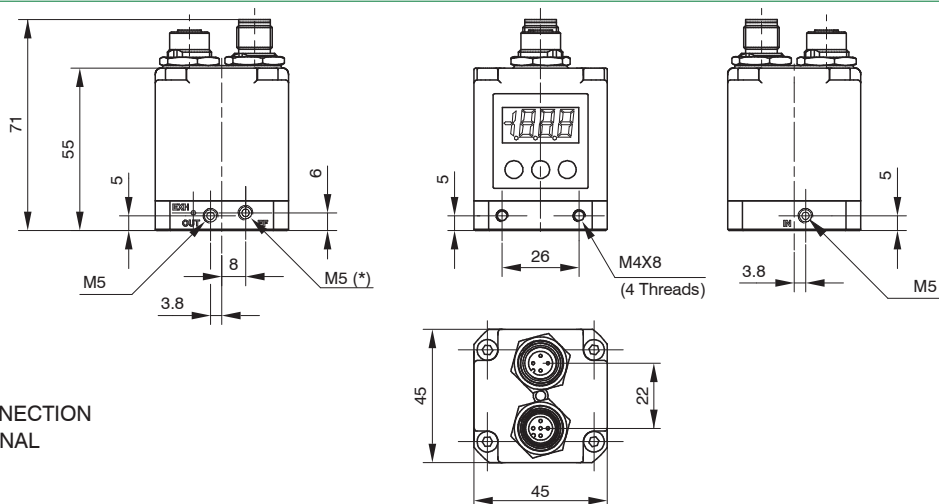

\* = EXTERNAL FEEDBACK INPUT CONNECTION  
(AVAILABLE ONLY ON THE EXTERNAL FEEDBACK VERSION)

Size 1

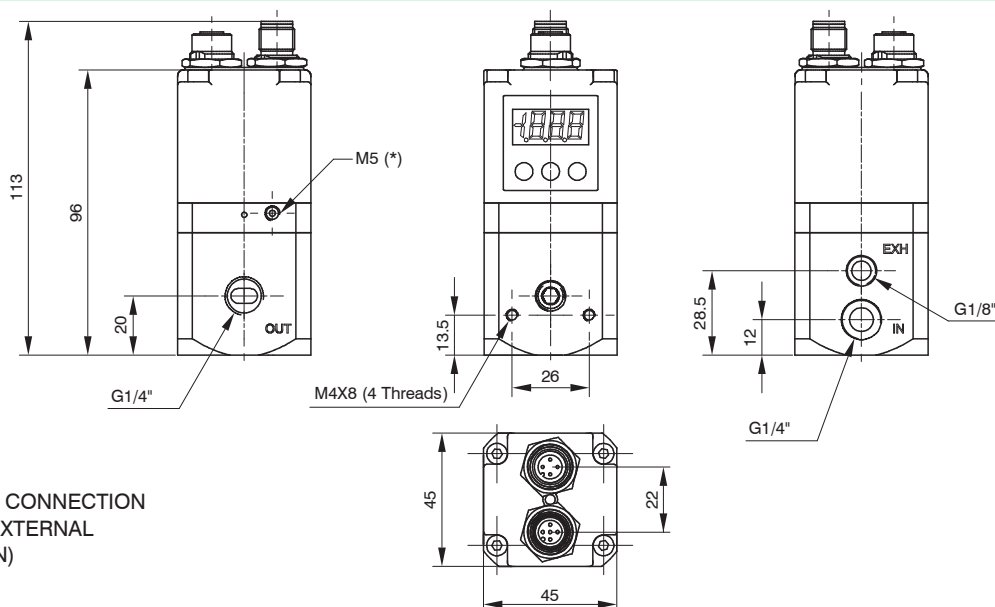

\* = EXTERNAL FEEDBACK INPUT CONNECTION  
(AVAILABLE ONLY ON THE EXTERNAL FEEDBACK VERSION)

Size 3

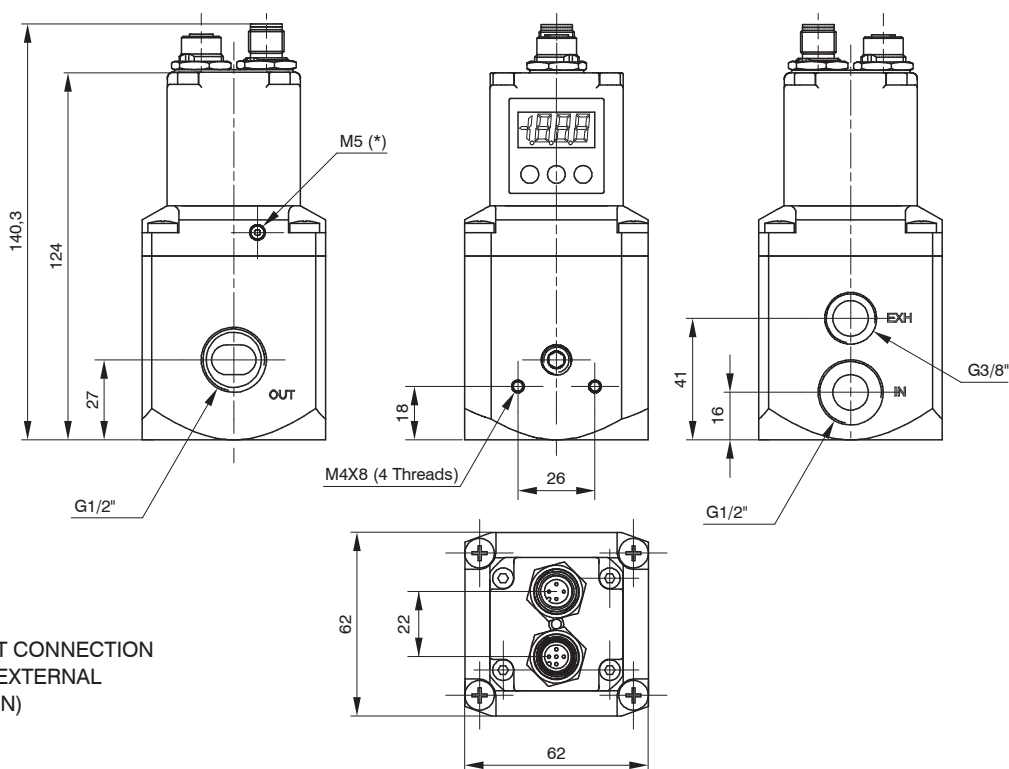

\* = EXTERNAL FEEDBACK INPUT CONNECTION  
(AVAILABLE ONLY ON THE EXTERNAL FEEDBACK VERSION)

2 AIR SERVICE UNITS

**Mounting options ("521 M12 version" - CANopen® version)**

In addition to mounting directly using the M4 tapping on the body, the 170M5 bracket may also be used, as shown below:

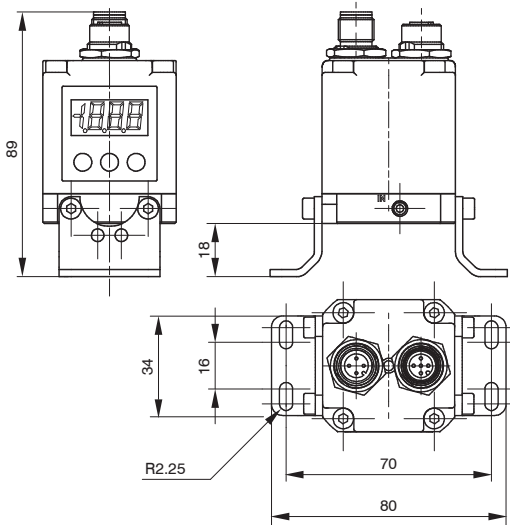

Size 0



Size 1

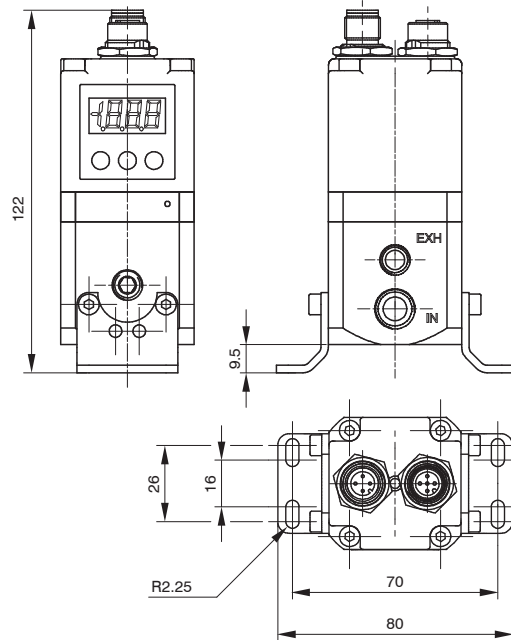

Size 3

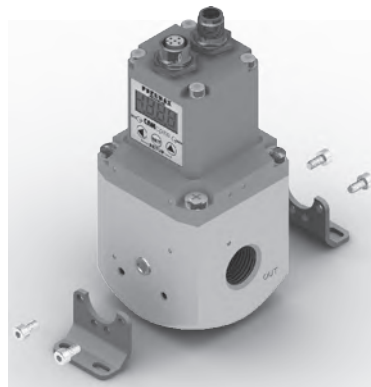
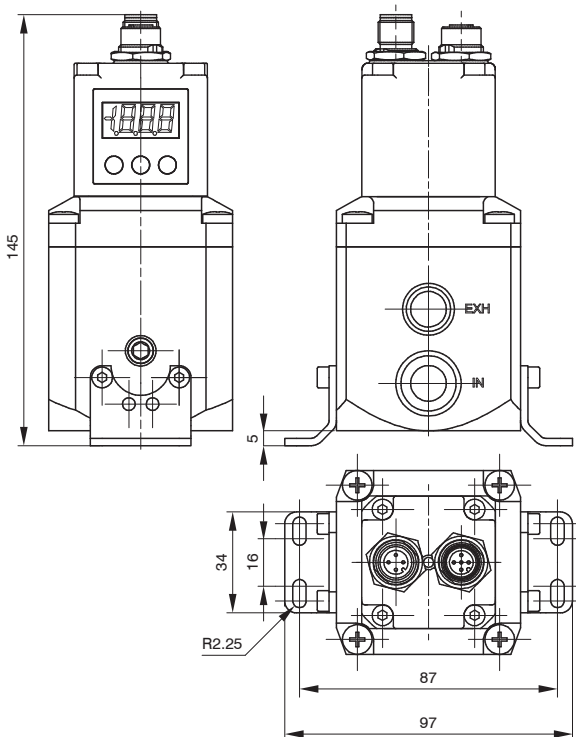

Overall dimensions ("521 M12 BASIC version")

Size 0

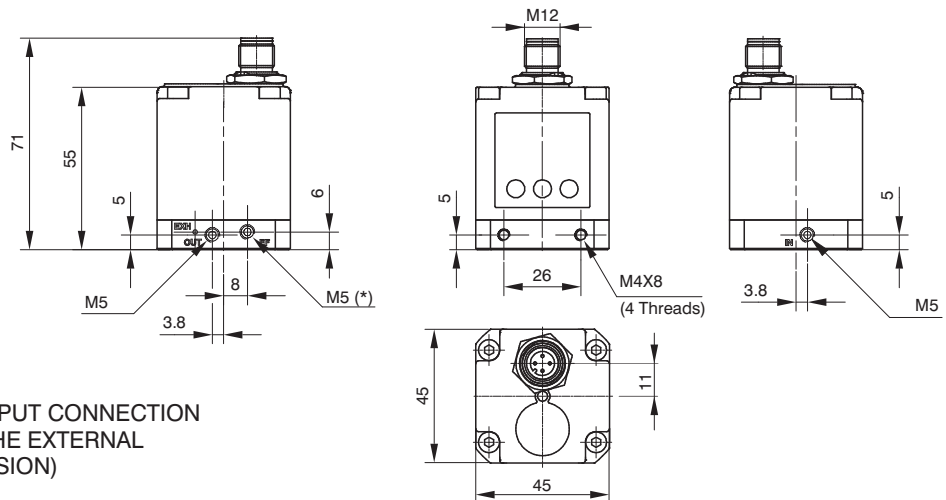

\* = EXTERNAL FEEDBACK INPUT CONNECTION  
(AVAILABLE ONLY ON THE EXTERNAL  
FEEDBACK VERSION)

Size 1

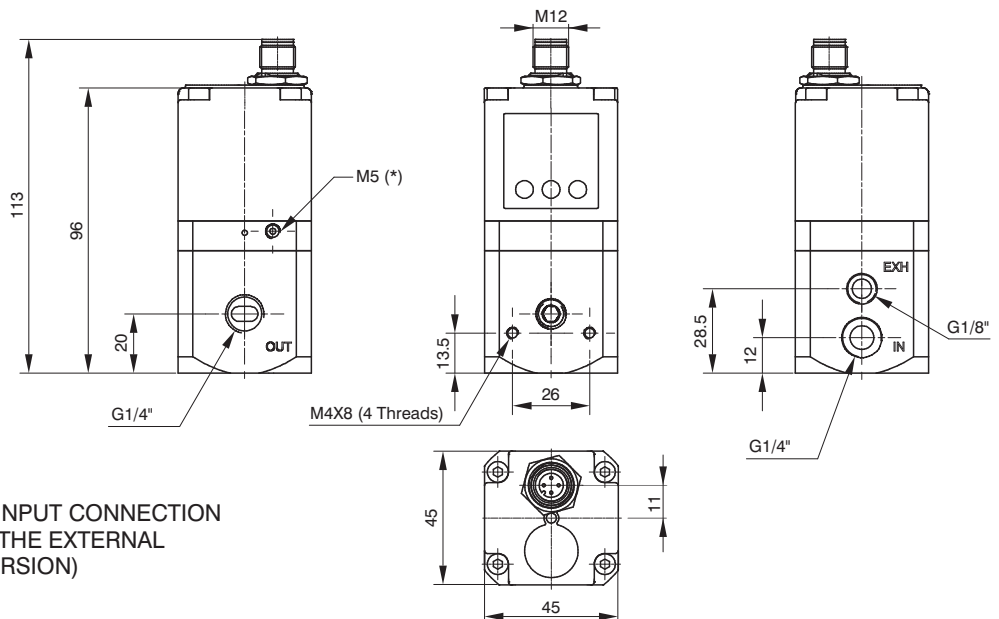

\* = EXTERNAL FEEDBACK INPUT CONNECTION  
(AVAILABLE ONLY ON THE EXTERNAL  
FEEDBACK VERSION)

Size 3

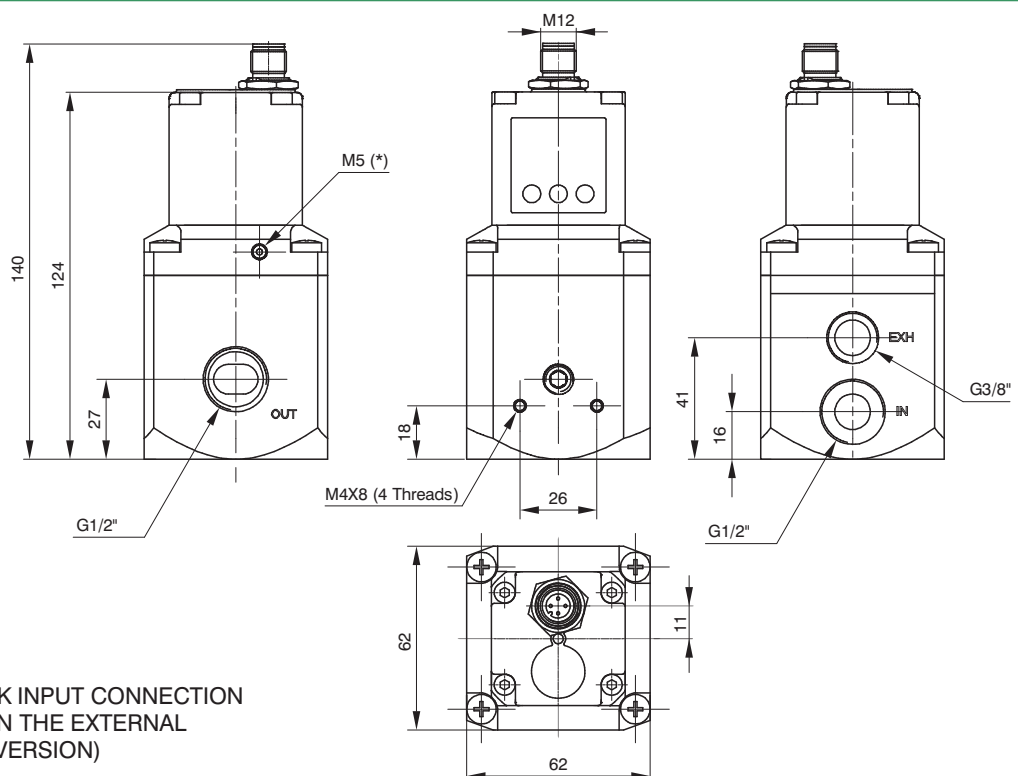

\* = EXTERNAL FEEDBACK INPUT CONNECTION  
(AVAILABLE ONLY ON THE EXTERNAL  
FEEDBACK VERSION)

2 AIR SERVICE UNITS



**Mounting options ("521 M12 BASIC version")**

In addition to mounting directly using the M4 tapping on the body, the 170M5 bracket may also be used, as shown below:

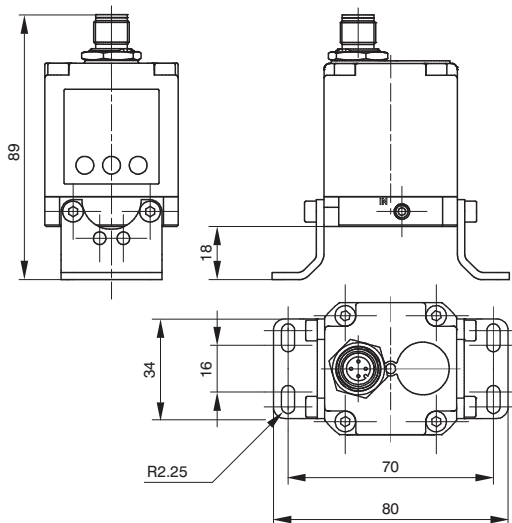

Size 0

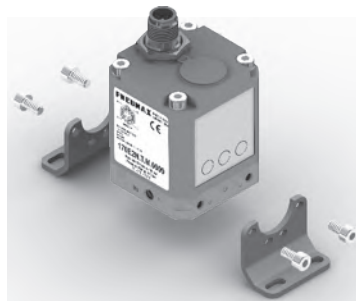

Size 1

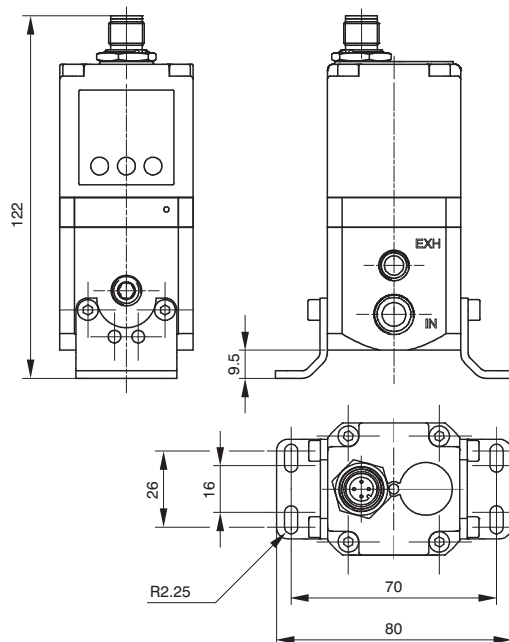

Size 3

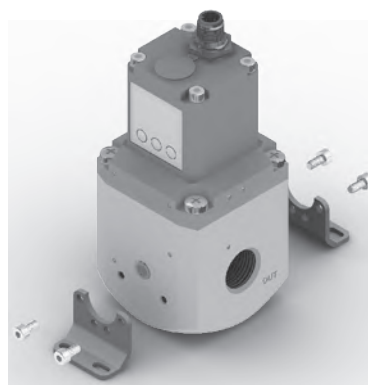
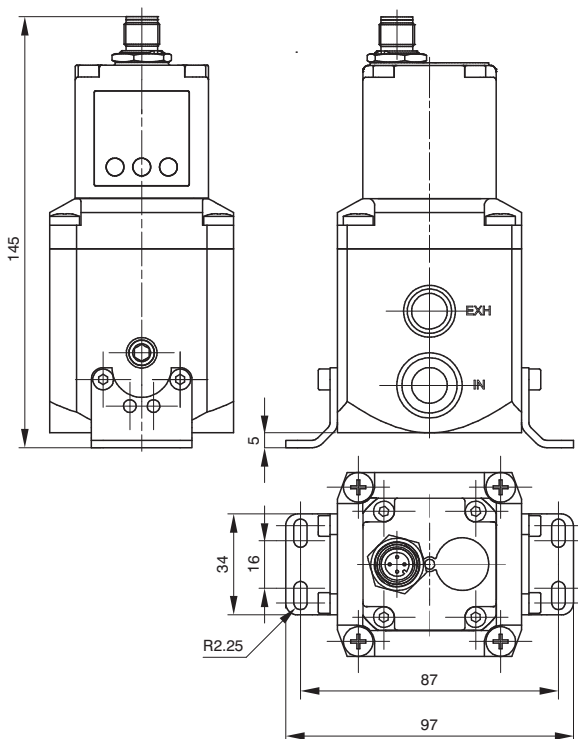

Overall dimensions ("521 M12 version" - Standard version)

Size 0

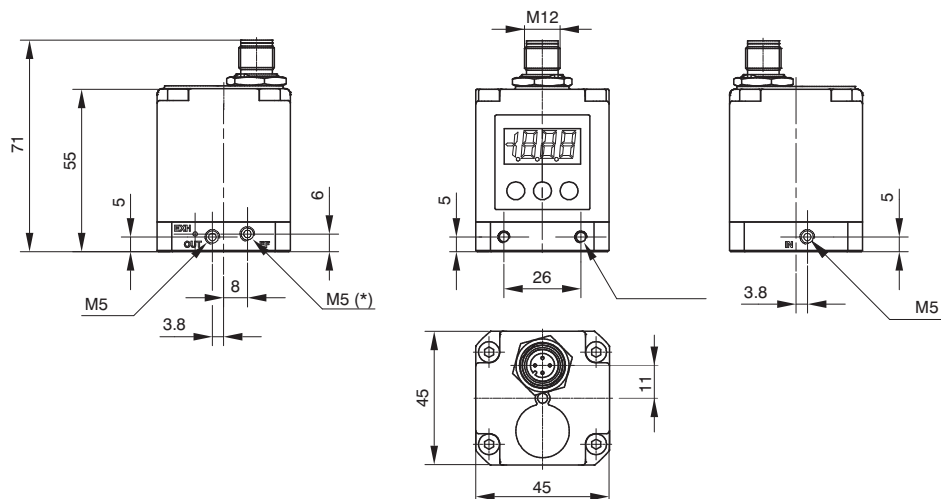

Size 1

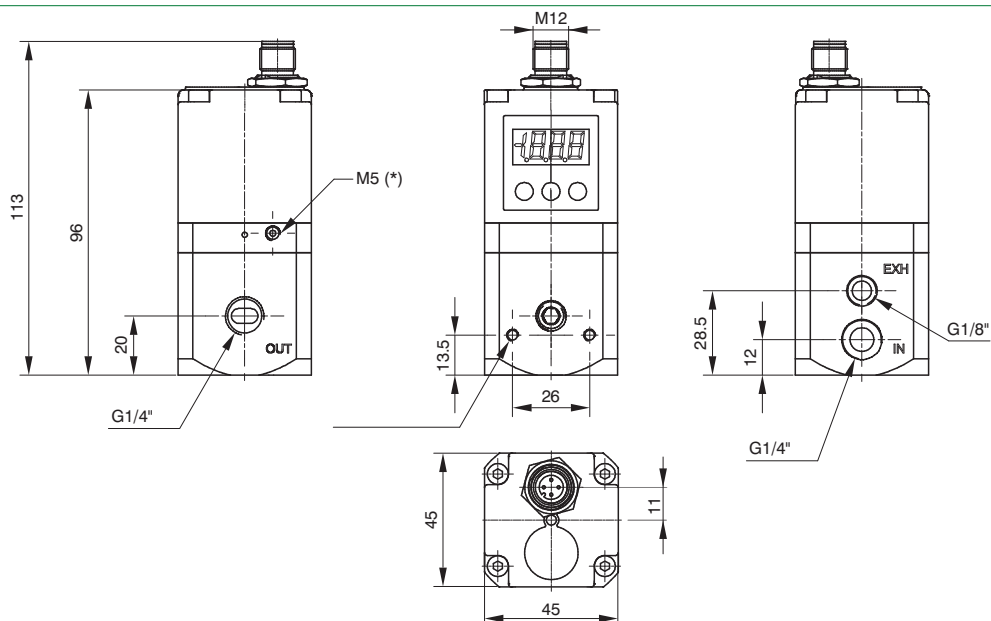

Size 3

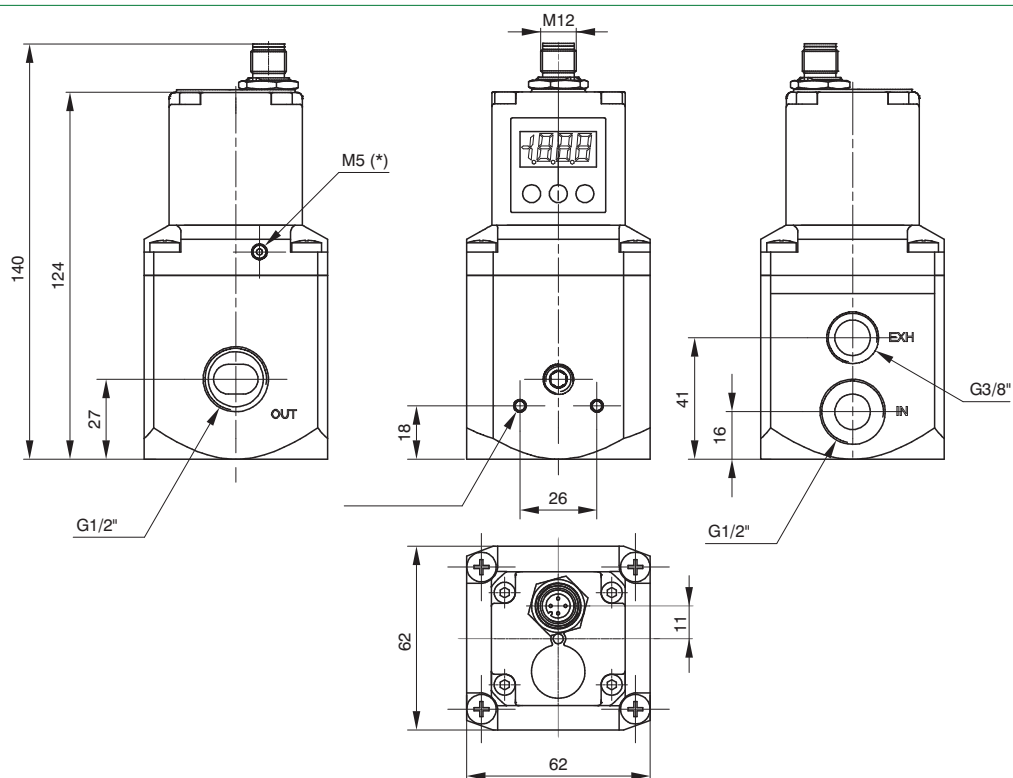

**Mounting options ("521 M12 version" - Standard version)**

In addition to mounting directly using the M4 tapping on the body, the 170M5 bracket may also be used, as shown below:

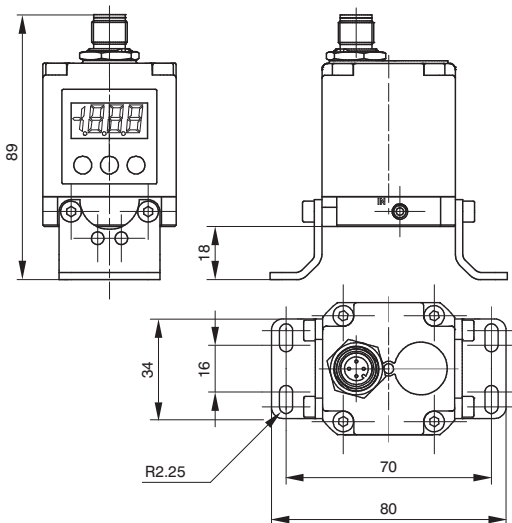

Size 0

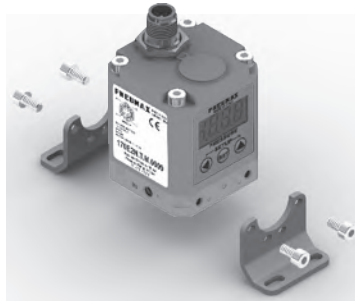

Size 1

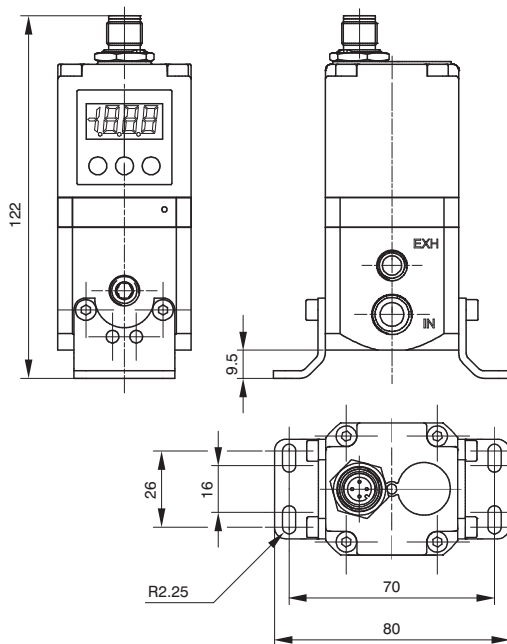

Size 3

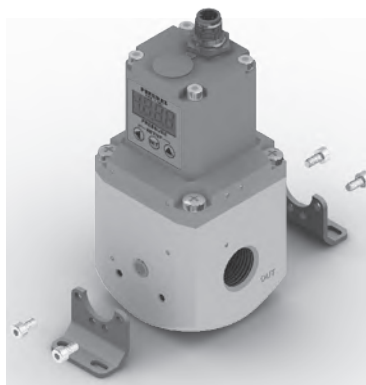
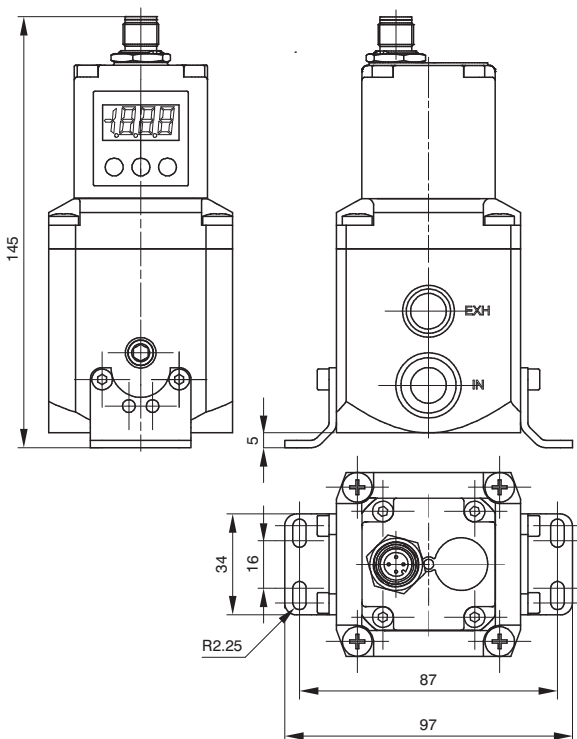

Overall dimensions ("521 IO-Link version")

Size 0

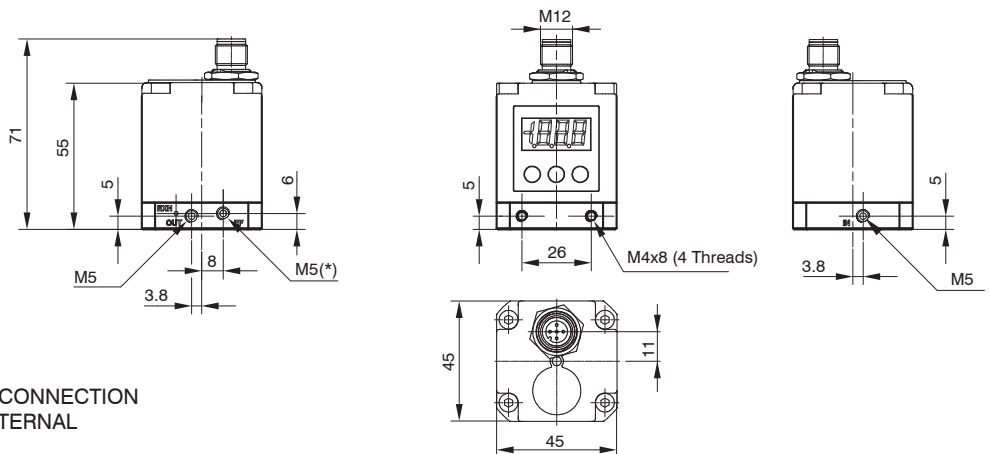

\* = EXTERNAL FEEDBACK INPUT CONNECTION  
(AVAILABLE ONLY ON THE EXTERNAL  
FEEDBACK VERSION)

Size 1

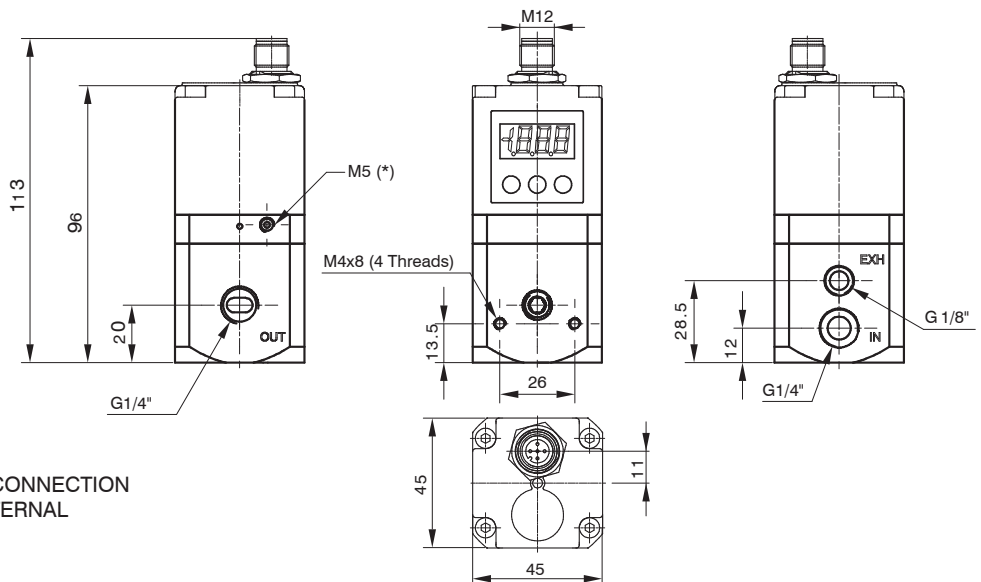

\* = EXTERNAL FEEDBACK INPUT CONNECTION  
(AVAILABLE ONLY ON THE EXTERNAL  
FEEDBACK VERSION)

Size 3

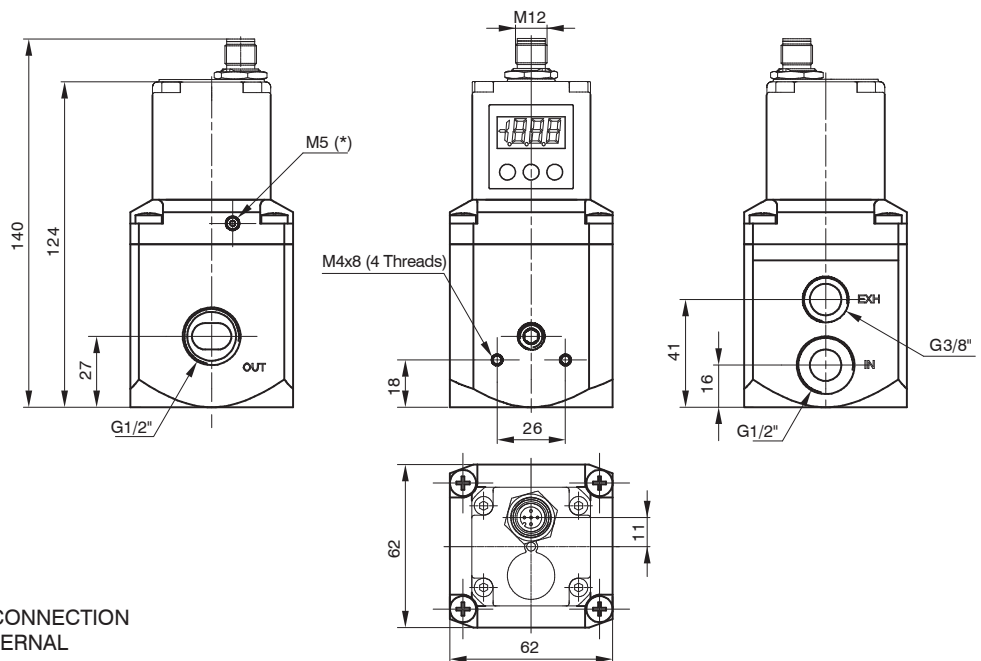

\* = EXTERNAL FEEDBACK INPUT CONNECTION  
(AVAILABLE ONLY ON THE EXTERNAL  
FEEDBACK VERSION)

2 AIR SERVICE UNITS

**Mounting options ("521 IO-Link version")**

In addition to mounting directly using the M4 tappings on the body, the 170M5 bracket may also be used, as shown below.

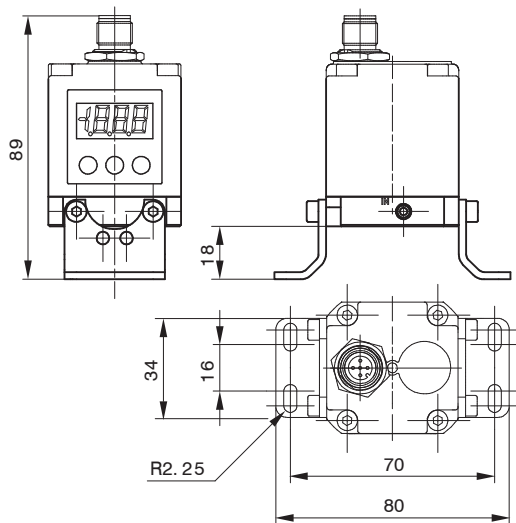

Size 0



Size 1

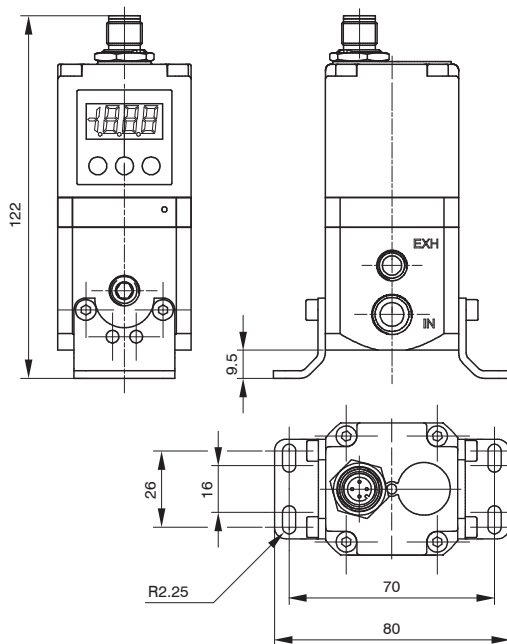

2  
AIR SERVICE UNITS

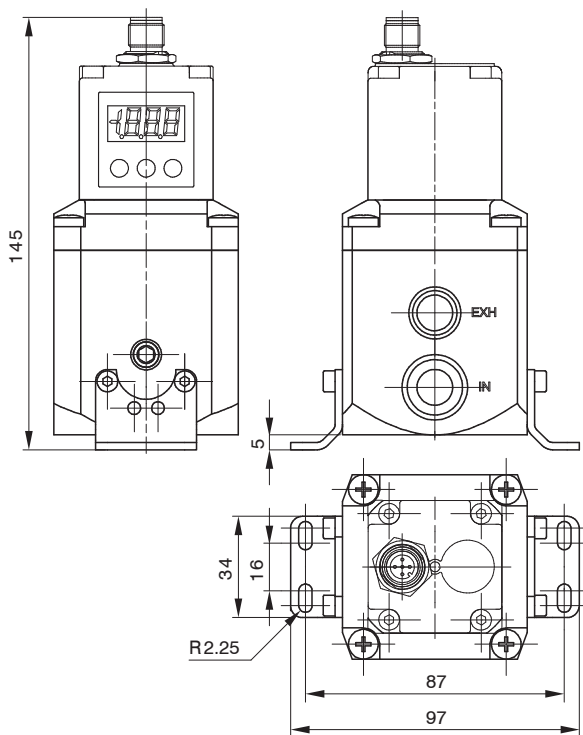

Size 3





## Installation/Operation

### PNEUMATIC CONNECTION



The compressed air is connected by means of M5 threaded holes (for size 0 regulators), G 1/4" threaded holes (for size 1 regulators) and G 1/2" threaded holes (for size 3 regulators) on the body.  
Before making the connections, eliminate any impurities in the connecting pipes to prevent chippings or dust entering the unit. Do not supply the circuit with more than 10 bar pressure and make sure that the compressed air is dried (excessive condensate could cause the appliance to malfunction) and filtered at 5 micron. The supply pressure to the regulator must always be at least 1 bar greater than the desired outlet pressure.  
If a silencer is applied to the discharge path the unit response time may change; periodically check that the silencer is not blocked and replace it if necessary.

### ELECTRICAL CONNECTION



For the electrical connection a SUB-D 15-pole female or a M12 connector is used (accordingly to the model, to be ordered separately). Wire in accordance with the wiring diagram shown below.

**Warning: INCORRECT CONNECTIONS MAY DAMAGE THE DEVICE**

### NOTES ON OPERATION



If the electric supply is interrupted, the outlet pressure is maintained at the set value. However, maintaining the exact value cannot be ensured as it is impossible to operate the solenoid valves.

In order to discharge the circuit downstream, zero the reference, make sure that the display shows a pressure value equal to zero and then disconnect the electric power supply.

A version of the device is available that exhausts the downstream circuit when the power supply is removed. (Option "A" at the end of the ordering code).

If the compressed-air supply is suspended and the electric power supply is maintained a whirring will be heard that is due to the solenoid valves; an operating parameter can be activated (P18) that triggers the regulator protection whenever the requested pressure is not reached within 4 seconds of the reference signal being sent. In this case the system will intervene to interrupt the control of the solenoid valves. Every twenty seconds, the unit will start the reset procedure until standard operating conditions have been restored.

#### "521" Standard version with D-SUB connector



TOP VIEW OF THE REGULATOR CONNECTOR

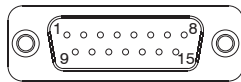

**CONNECTOR PINOUT:**

- 1 = DIGITAL INPUT 1
- 2 = DIGITAL INPUT 2
- 3 = DIGITAL INPUT 3
- 4 = DIGITAL INPUT 4
- 5 = DIGITAL INPUT 5
- 6 = DIGITAL INPUT 6
- 7 = DIGITAL INPUT 7
- 8 = ANALOG INPUT / DIGITAL INPUT 8
- 9 = SUPPLY (24 VDC)
- 10 = DIGITAL OUTPUT (24 VDC PNP)
- 11 = ANALOG OUTPUT (CURRENT)
- 12 = ANALOG OUTPUT (VOLTAGE)
- 13 = Rx RS-232
- 14 = Tx RS-232
- 15 = GND

#### "521" M12 BASIC and Standard versions

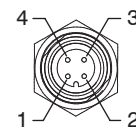

M12 4P MALE

**M12 BASIC version**

- CONNECTOR PINOUT:**
- 1 = POWER SUPPLY (24 VDC)
  - 2 = NC
  - 3 = GND
  - 4 = ANALOG INPUT

**M12 Standard version**

- CONNECTOR PINOUT:**
- 1 = POWER SUPPLY (24 VDC)
  - 2 = ANALOG OUTPUT (depending on the model)
  - 3 = GND
  - 4 = ANALOG INPUT

#### "521" CANopen® version with D-SUB connector



TOP VIEW OF THE REGULATOR CONNECTOR

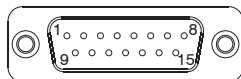

**CONNECTOR PINOUT:**

- 1 = CAN\_SHIELD
- 2 = CAN\_V+
- 3 = CAN\_GND
- 4 = CAN\_H
- 5 = CAN\_L
- 6 = NC
- 7 = NC
- 8 = NC
- 9 = SUPPLY (+24 VDC)
- 10 = CAN\_SHIELD
- 11 = CAN\_V+
- 12 = CAN\_GND
- 13 = CAN\_H
- 14 = CAN\_L
- 15 = GND

#### "521" CANopen® version with M12 connector

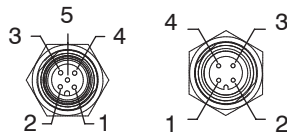
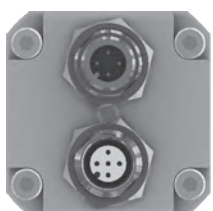

M12 5P FEMALE

M12 4P MALE

#### "521 IO-Link version"

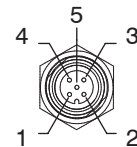

M12 5P MALE

**CONNECTOR PINOUT:**

- 1 = L+
- 2 = +24 VDC (P24)
- 3 = L-
- 4 = C/Q
- 5 = GND (N24)

2 AIR SERVICE UNITS



**ORDERING CODES**

"521" standard version with SUB-D 15 poles



**17 E2N. . D . .**

**VARIANT**

- = Standard Version  
(no additional letter required)
- E** = External pressure feedback
- A** = Exhaust downstream pressure  
when power supply is removed
- AE** = A Variant + E Variant

**PRESSURE RANGE :**

- 0001** = Range 0 - 1 bar
- 0005** = Range 0 - 5 bar
- 0009** = Range 0 - 9 bar

**MANAGEMENT :**

- C** = Current signal (4-20 mA / 0-20 mA)
- T** = Voltage signal (0-10 V / 0-5 V / 1-5 V)

**SIZE :**

- 0** = Size 0
- 1** = Size 1
- 3** = Size 3

**ORDERING CODES**

"521" CANopen® version with SUB-D 15 poles



**17 E2N. S . C . .**

**VARIANT**

- = Standard Version  
(no additional letter required)
- E** = External pressure feedback
- A** = Exhaust downstream pressure  
when power supply is removed
- AE** = A Variant + E Variant

**PRESSURE RANGE :**

- 0001** = Range 0 - 1 bar
- 0005** = Range 0 - 5 bar
- 0009** = Range 0 - 9 bar

**SIZE :**

- 0** = Size 0
- 1** = Size 1
- 3** = Size 3

**Accessories**

Model with SUB-D 15 poles connector	
	<b>5300.F15.00.00</b> : Straight connector + Casing IP65
	<b>5300.F15.00.03</b> : Straight connector + Cable 3 meters
	<b>5300.F15.00.05</b> : Straight connector + Cable 5 meters
	<b>5300.F15.90.00</b> : 90° connector + Casing IP65
	<b>5300.F15.90.03</b> : 90° connector + Cable 3 meters
	<b>5300.F15.90.05</b> : 90° connector + Cable 5 meters

\* Whitout cable

Fixing bracket
<b>170M5</b>

2 AIR SERVICE UNITS

**ORDERING CODES**

"521 M12 version" - CANopen® version



17 E2N. M . C . . . . .

**SIZE :**  
0 = Size 0  
1 = Size 1  
3 = Size 3

**VARIANT**  
= Standard Version  
(no additional letter required)  
**E** = External pressure feedback  
**A** = Exhaust downstream pressure  
when power supply is removed  
**AE** = A Variant + E Variant

**PRESSURE RANGE :**  
0001 = Range 0 - 1 bar  
0005 = Range 0 - 5 bar  
0009 = Range 0 - 9 bar

**Note:**  
This model doesn't include  
the terminating resistor

**Accessories**

Model with M12 connector
<b>POWER SUPPLY connector</b>
Female straight connector M12A 4P
5312A.F04.00

Model with M12 connector
<b>NETWORK connector</b>
Male straight connector M12A 5P
5312A.M05.00

Fixing bracket
170M5

**ORDERING CODES**

"521 M12 BASIC version"



17 E2N. . M . . . . .

**SIZE :**  
0 = Size 0  
1 = Size 1  
3 = Size 3

**VARIANT**  
= Standard Version  
(no additional letter required)  
**E** = External pressure feedback  
**A** = Exhaust downstream pressure  
when power supply is removed  
**AE** = A Variant + E Variant

**PRESSURE RANGE :**  
0001 = Range 0 - 1 bar  
0005 = Range 0 - 5 bar  
0009 = Range 0 - 9 bar

**MANAGEMENT :**  
**C** = Current signal (4-20 mA)  
**T** = Voltage signal (0-10 V)

**Note:**  
This model doesn't include display a keyboard.  
Therefore it is not possible to set the parameters.  
Unless specifically requested it is provided with  
all parameters set with default values.  
Personalisations are available.

**Accessories**

Model with M12 connector
<b>POWER SUPPLY connector</b>
Female straight connector M12A 4P
5312A.F04.00

Fixing bracket
170M5





**ORDERING CODES**

"521 M12 version" - Standard version

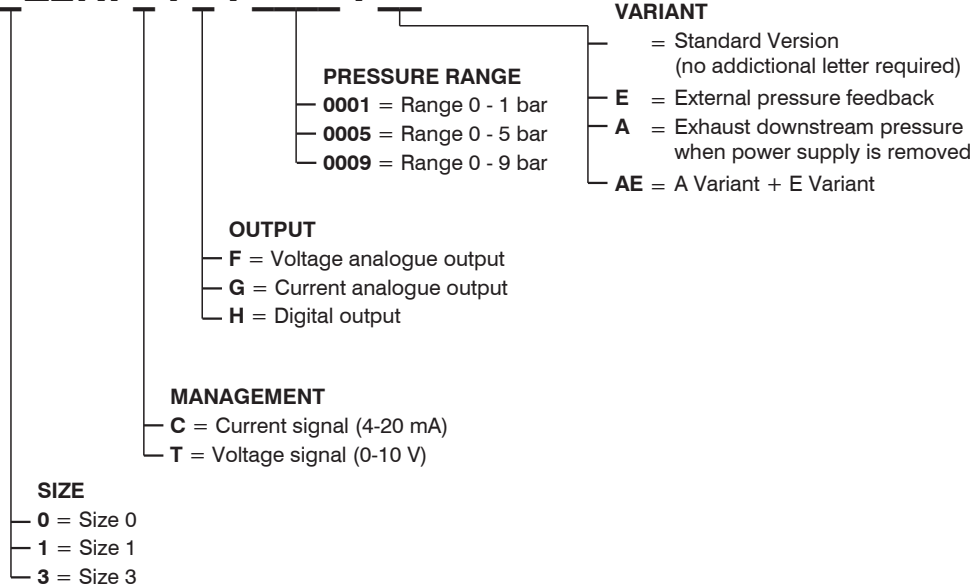

**17 E2N.**



**Accessories**

Model with M12 connector
<b>POWER SUPPLY connector</b>
Female straight connector M12A 4P
<b>5312A.F04.00</b>

<b>Fixing bracket</b>
<b>170M5</b>

**ORDERING CODES**

"521 IO-Link version"



**17 E2N. I. B.**

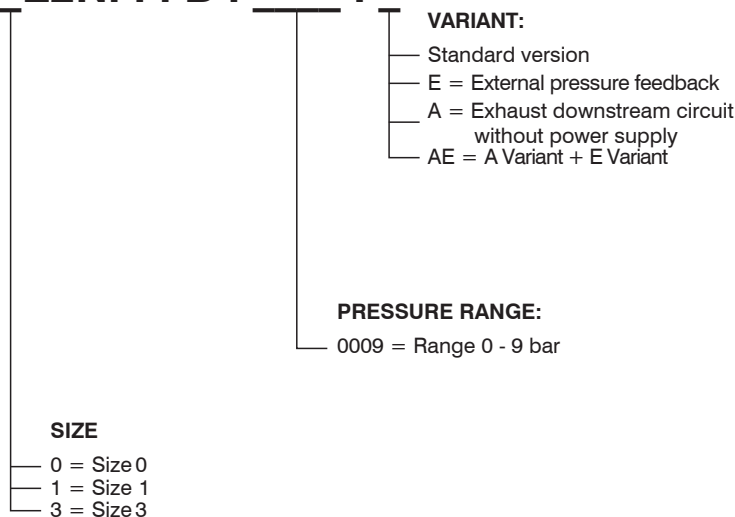

**Accessories**

Model with M12 connector
<b>POWER SUPPLY connector</b>
Female straight connector M12A 5P
<b>5312A.F05.00</b>

<b>Fixing bracket</b>
<b>170M5</b>



## Series 1700 - Miniaturized proportional pressure regulator

### General

Modern industrial applications constantly require more sophisticated and better performing pneumatic components. Flexibility and adaptability are key factor when designing a machine. The possibility to change the application parameter during operation such as for example the speed of a cylinder or the force generated by a rotary actuator are beneficial to the designer.

In the past it was necessary to design complicated pneumatic circuits based on pneumatic logic elements which required a lot of space and complicated set up, today, thanks to the electronic proportional regulators such operations are extremely easy to achieve and offer even more flexibility.

Pneumax miniaturized proportional regulators series integrates all the main features of the 521 series with the exclusion of the display and analogue/digital output.

High precision in pressure regulation, fast response speed, assembling options and reduced dimensions are the main advantages.

2

AIR SERVICE UNITS

### Features

Pneumatic	Fluid	Air filtered at 5 micron and dehumidified		
	Minimum inlet pressure	Desired outlet pressure + 1 bar		
	Maximum inlet pressure	10 bar		
	Outlet pressure	Ordering code	009	
		Pressure value	0 - 9 bar	
	Nominal flowrate from 1 to 2 (6 bar $\Delta p$ 1 bar)	7 NI /min		
	Discharge flowrate (at 6 bar with 1 bar overpressure)	7 NI /min		
	Air consumption	M5 / Ø4		
	Operating connection	M5 / Ø4		
	Exhaust connection	M5 / Ø4		
Maximum fitting tightening	3 Nm			
Electric	Supply voltage	24VDC $\pm$ 10% (stabilised with ripple <1%)		
	Standby current consumption	55 mA		
	Current consumption with solenoid valves on	145 mA		
	Reference signal	Voltage*	0 - 10 V	
		Current*	4 - 20 mA	
	Input impedance	Voltage	10 K $\Omega$	
		Current	250 $\Omega$	
Analog outputs voltage	0,2 - 10 V (10 V to 9 bar)			
Connector	M8 4 poles			
Functional	Linearity	< $\pm$ 0,3 % F.S.		
	Hysteresis	<0,3 % F.S.		
	Repeatability	< $\pm$ 0,5 % F.S.		
	Sensitivity	< $\pm$ 0,5 % F.S.		
	Assembly position	Indifferent		
	Protection grade	IP65 (with casing fitted)		
	Ambient temperature	-5° - 50°C / 23° - 122°F		
Constructional	Body	Technopolymer		
	Seals	NBR		
	Cover for electrical part	Technopolymer		
	Weight	60 g		

\* Request during ordering process

Proportional pressure regulator

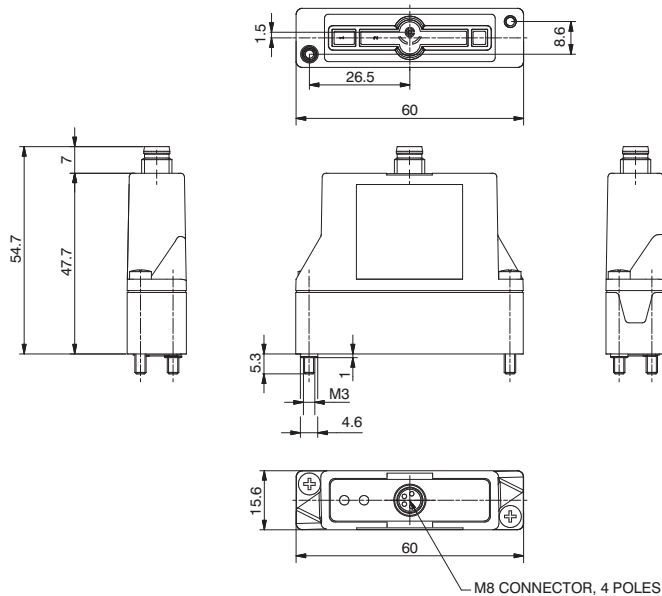

Ordering code	
<b>170EPM.V.M.0</b>	
PROTECTION	
<b>P</b>	0 = Parameter 18 active 2 = Parameter 18 not active
VERSION	
<b>V</b>	T = Voltage signal C = Current signal
PRESSURE RANGE	
<b>G</b>	001= Range 0 - 1 bar 005= Range 0 - 5 bar 009= Range 0 - 9 bar

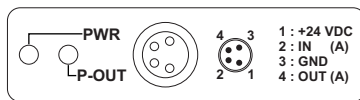
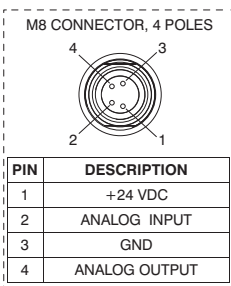

<b>PWR</b>	Green Led: The regulator is properly powered
<b>P-OUT</b>	Green Led: lights up when the outlet pressure is higher than the desired pressure minus 0.2 bar and less than the desired pressure more 0.2 bar

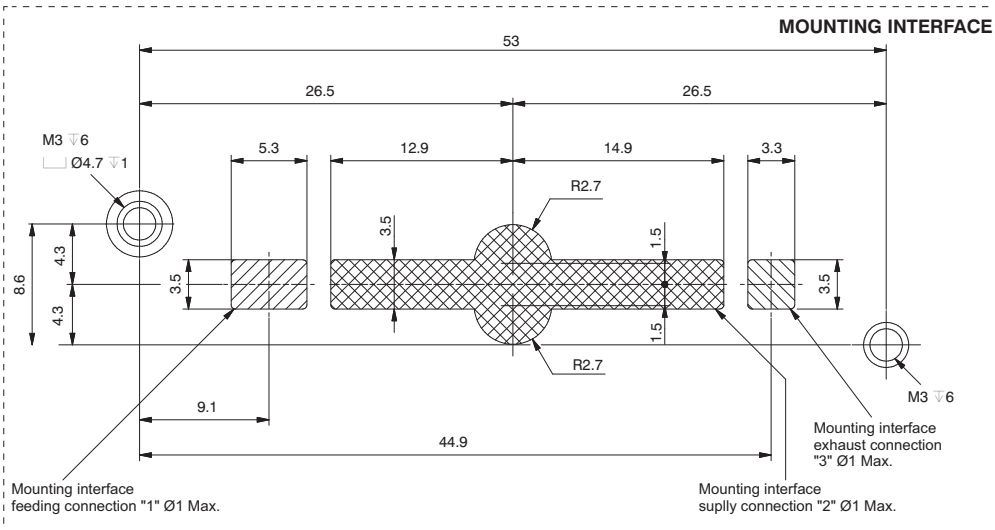



► Proportional Pressure Regulator c/w M5 In-Line Single Base

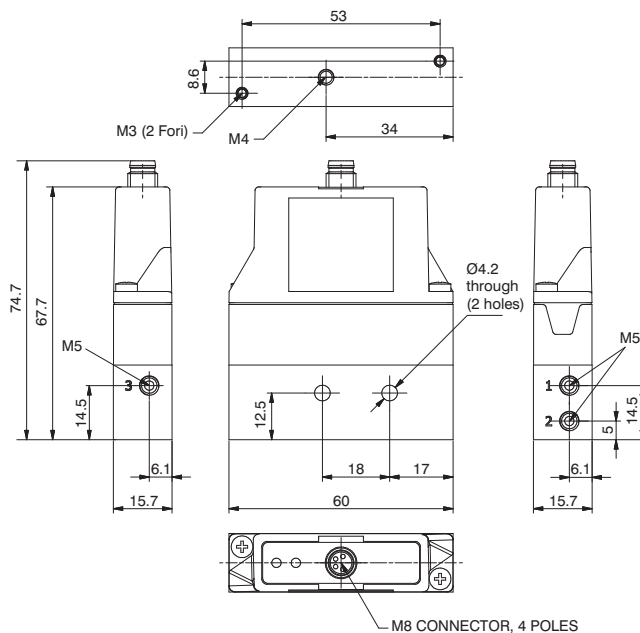

Ordering code	
<b>170EPM.V.M.G.FO</b>	
PROTECTION	
<b>P</b>	0 = Parameter 18 active
	2 = Parameter 18 not active
VERSION	
<b>V</b>	T = Voltage signal
	C = Current signal
PRESSURE RANGE	
<b>G</b>	001= Range 0 - 1 bar
	005= Range 0 - 5 bar
	009= Range 0 - 9 bar

Weight: 110 g

► M5 In-Line Single Base

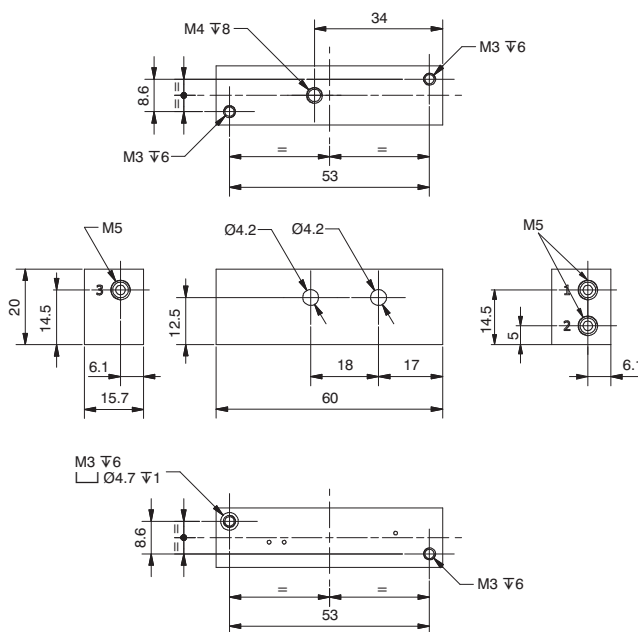

Ordering code	
<b>170M1.FO</b>	

Weight: 50 g

► Proportional Pressure Regulator c/w M5 Bottom Entry Base

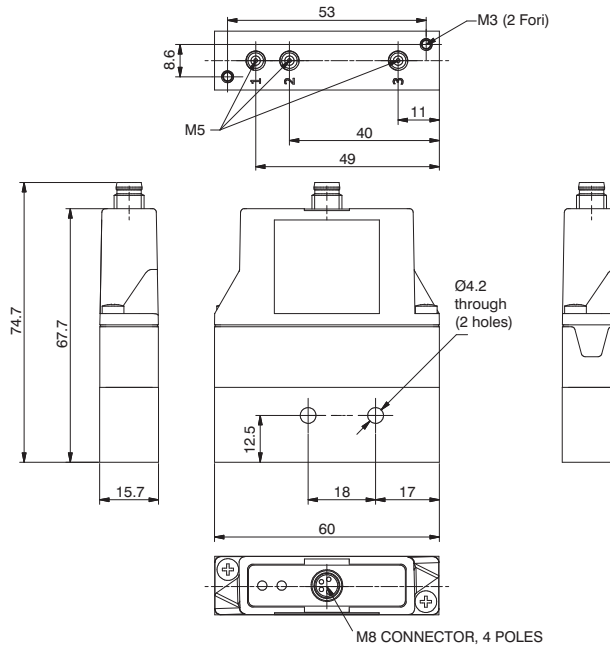

Ordering code	
<b>170E<sup>P</sup>M.V.M.G.FV</b>	
PROTECTION	
<b>P</b>	0 = Parameter 18 active
	2 = Parameter 18 not active
VERSION	
<b>V</b>	T = Voltage signal
	C = Current signal
PRESSURE RANGE	
<b>G</b>	001 = Range 0 - 1 bar
	005 = Range 0 - 5 bar
	009 = Range 0 - 9 bar

Weight: 110 g

► M5 Bottom Entry Single Base

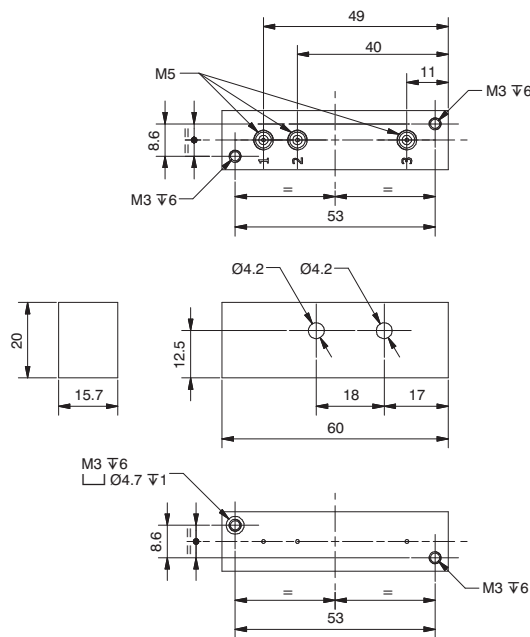

Ordering code	
<b>170M1.FV</b>	

Weight: 50 g



**Proportional Pressure Regulator c/w Modular In-Line Base**

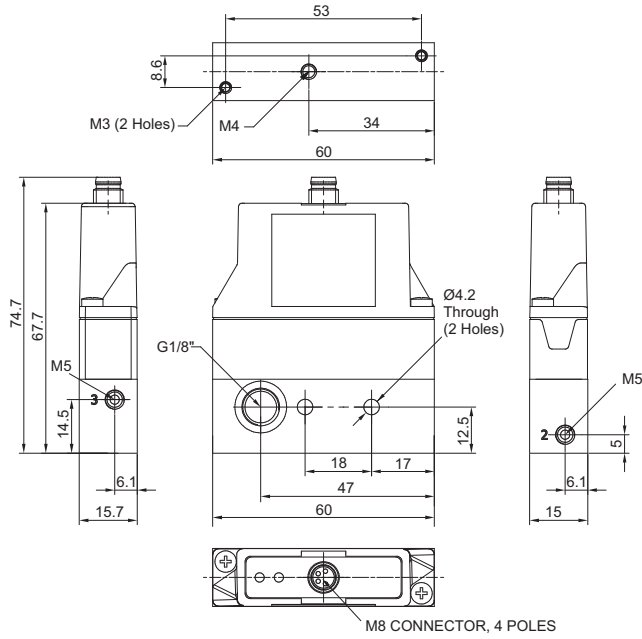

Ordering code	
<b>170EPM.V.M.0.FP</b>	
PROTECTION	
<b>P</b>	0 = Parameter 18 active
	2 = Parameter 18 not active
VERSION	
<b>V</b>	T = Voltage signal
	C = Current signal
PRESSURE RANGE	
<b>G</b>	001 = Range 0 - 1 bar
	005 = Range 0 - 5 bar
	009 = Range 0 - 9 bar

Weight: 110 g

**Single Modular In-Line Base**

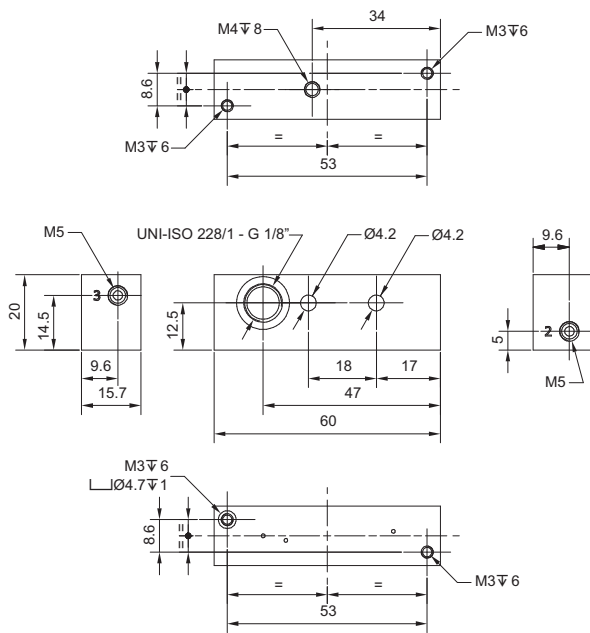

Ordering code	
<b>170M1.FP</b>	

Weight: 50 g

2 AIR SERVICE UNITS

Proportional Pressure Regulator c/w 4mm In-Line Single base

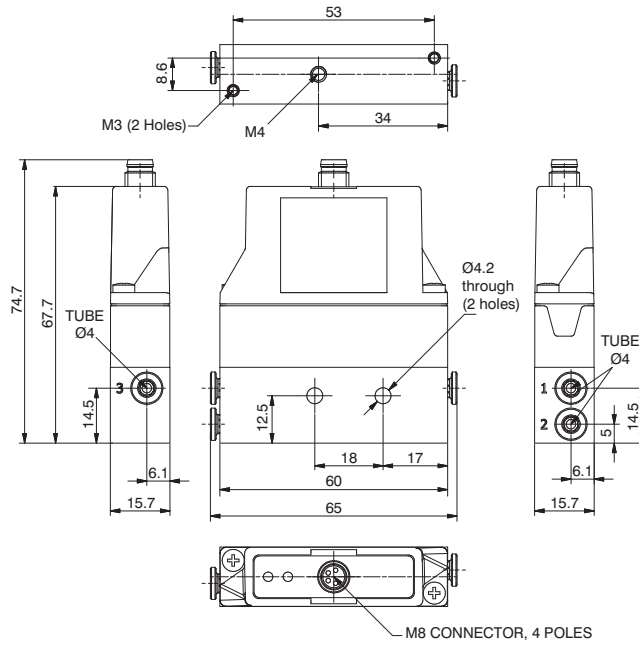

Ordering code	
<b>170E0M.V.M.G.TO</b>	
PROTECTION	
<b>P</b>	0 = Parameter 18 active
	2 = Parameter 18 not active
VERSION	
<b>V</b>	T = Voltage signal
	C = Current signal
PRESSURE RANGE	
<b>G</b>	001 = Range 0 - 1 bar
	005 = Range 0 - 5 bar
	009 = Range 0 - 9 bar

Weight: 110 g

Single 4mm In-Line Base

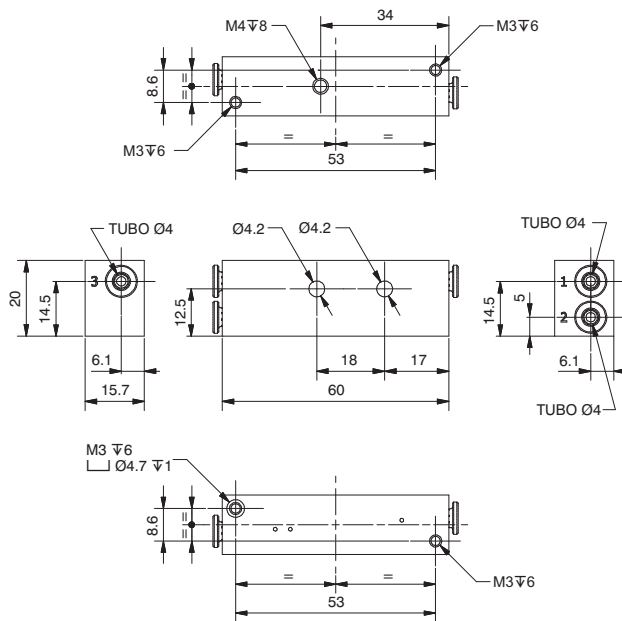

Ordering code	
<b>170M1.TO</b>	

Weight: 50 g

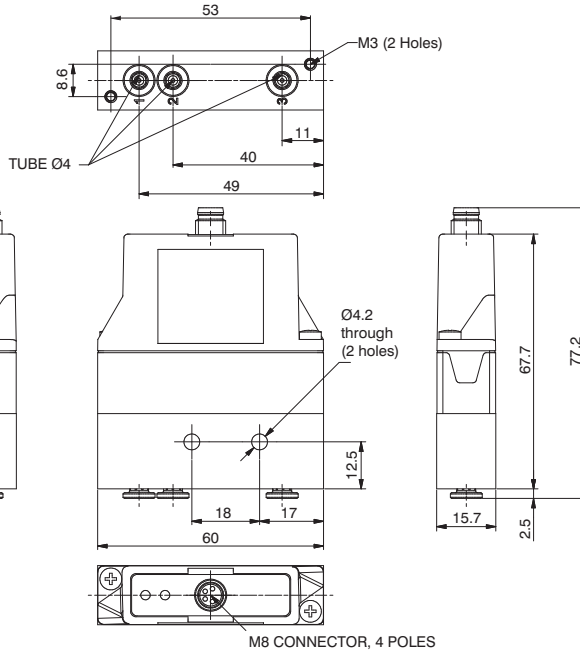

Weight: 110 g

Ordering code

**170EPM.V.M.⊙.TV**

PROTECTION

- P** 0 = Parameter 18 active
- 2 = Parameter 18 not active

VERSION

- V** T = Voltage signal
- C = Current signal

PRESSURE RANGE

- G** 001 = Range 0 - 1 bar
- 005 = Range 0 - 5 bar
- 009 = Range 0 - 9 bar

2 AIR SERVICE UNITS

Single 4mm Bottom Entry Base

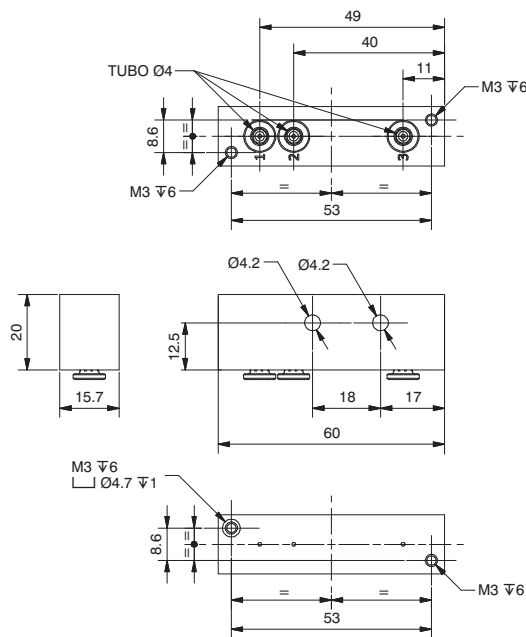

Weight: 50 g

Ordering code

**170M1.TV**



► Proportional Pressure Regulator c/w 4mm In-Line Modular Base

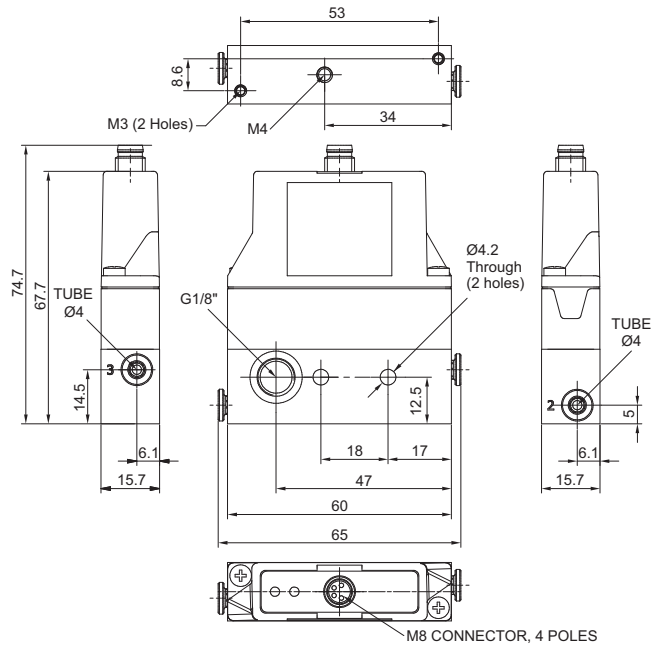

Ordering code	
<b>170E2M.V.M.C.TP</b>	
PROTECTION	
<b>P</b>	0 = Parameter 18 active
	2 = Parameter 18 not active
VERSION	
<b>V</b>	T = Voltage signal
	C = Current signal
PRESSURE RANGE	
<b>C</b>	001 = Range 0 - 1 bar
	005 = Range 0 - 5 bar
	009 = Range 0 - 9 bar

Weight: 110 g

► Single 4mm In-Line Modular Base

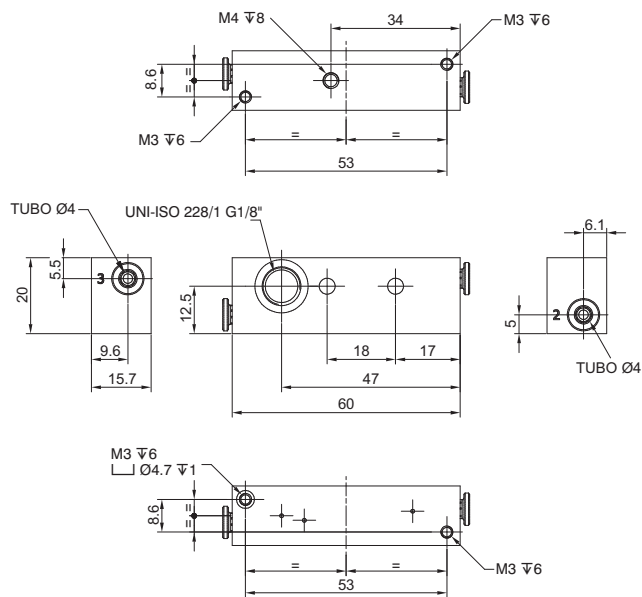

Ordering code	
<b>170M1.TP</b>	

Weight: 50 g

Proportional pressure regulator with external feedback

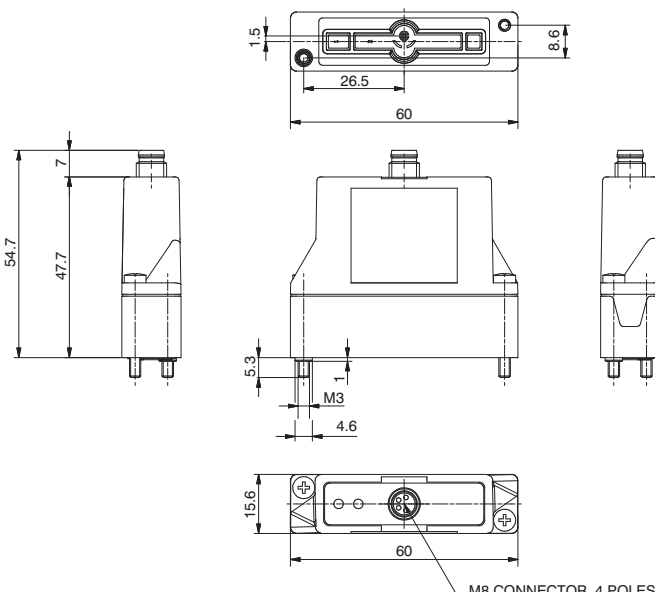

Ordering code	
<b>170E M.C.M. G.E</b>	
PROTECTION	
<b>P</b>	0 = Parameter 18 active
	2 = Parameter 18 not active
VERSION	
<b>V</b>	T = Voltage signal
	C = Current signal
PRESSURE RANGE	
<b>G</b>	001 = Range 0 - 1 bar
	005 = Range 0 - 5 bar
	009 = Range 0 - 9 bar

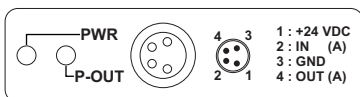
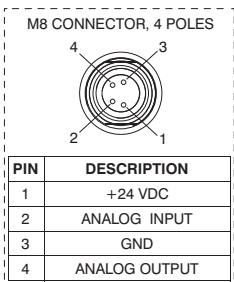

<b>PWR</b>	Green Led: The regulator is properly powered
<b>P-OUT</b>	Green Led: lights up when the outlet pressure is higher than the desired pressure minus 0.2 bar and less than the desired pressure more 0.2 bar

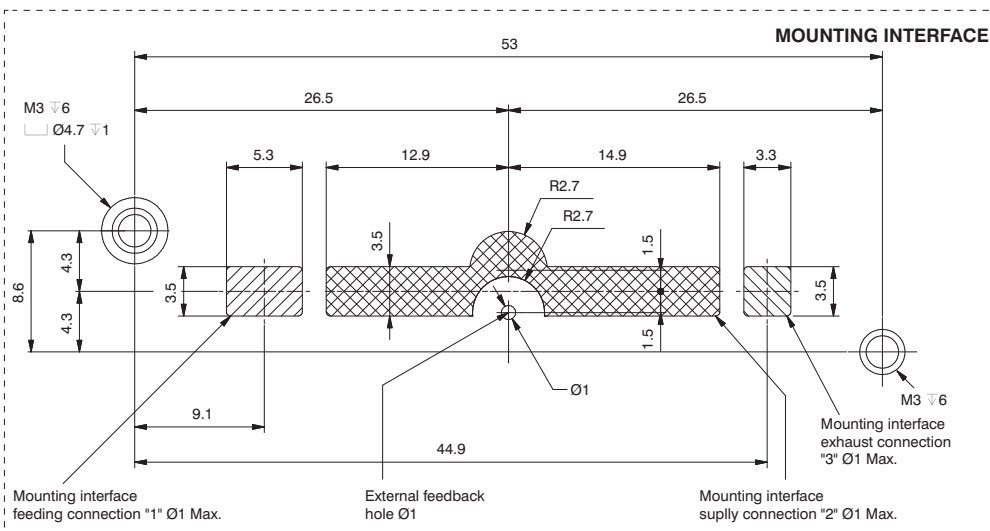

► Proportional Pressure Regulator c/w M5 In-Line Single Base with External Feedback

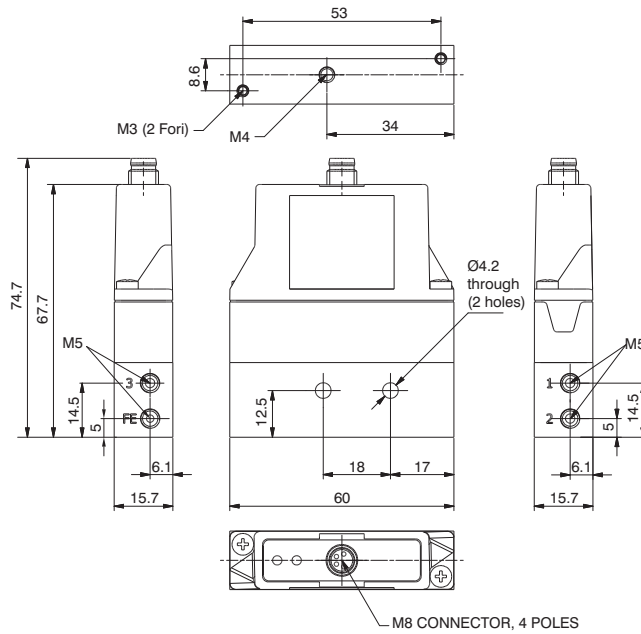

Ordering code	
<b>170EPM.V.M.⊙.EFO</b>	
PROTECTION	
<b>P</b>	0 = Parameter 18 active
	2 = Parameter 18 not active
VERSION	
<b>V</b>	T = Voltage signal
	C = Current signal
PRESSURE RANGE	
<b>⊙</b>	001 = Range 0 - 1 bar
	005 = Range 0 - 5 bar
	009 = Range 0 - 9 bar

Weight: 110 g

► Single M5 In-Line Base with External Feedback

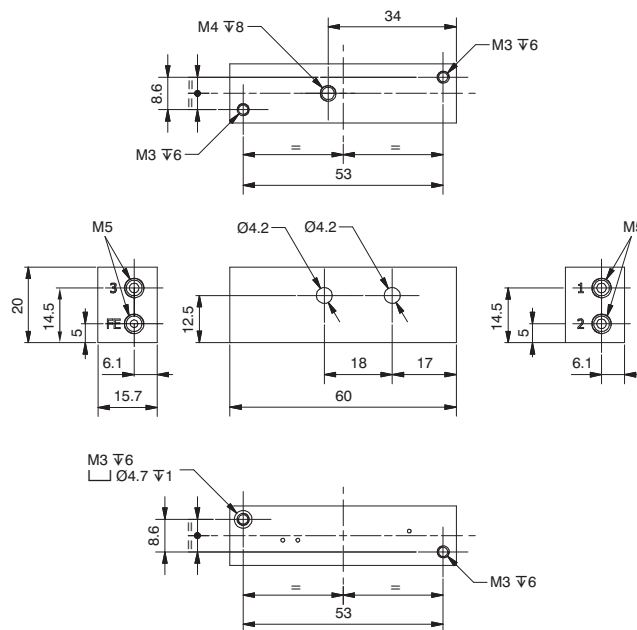

Ordering code	
<b>170M1.EFO</b>	

Weight: 50 g



Proportional Pressure Regulator c/w M5 Bottom Entry Base with External Feedback

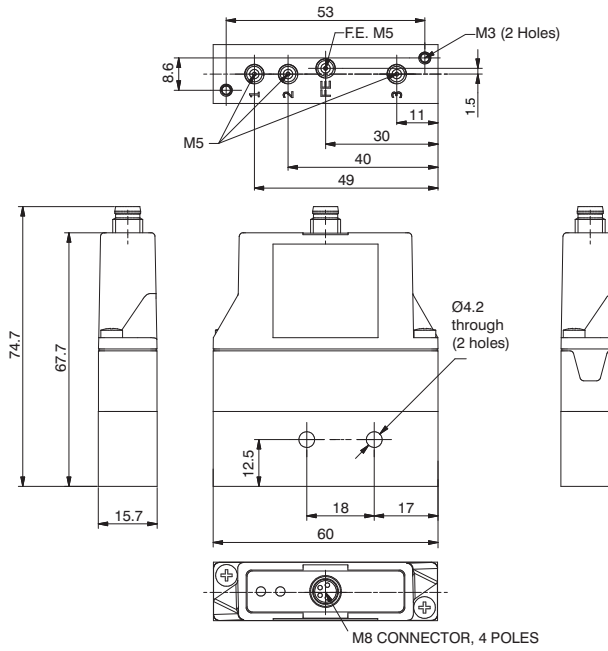

Ordering code	
<b>170EPM.V.M.G.EFV</b>	
PROTECTION	
<b>P</b>	0 = Parameter 18 active
	2 = Parameter 18 not active
VERSION	
<b>V</b>	T = Voltage signal
	C = Current signal
PRESSURE RANGE	
<b>G</b>	001 = Range 0 - 1 bar
	005 = Range 0 - 5 bar
	009 = Range 0 - 9 bar

Weight: 110 g

2 AIR SERVICE UNITS

Single M5 Bottom Entry Base with External Feedback

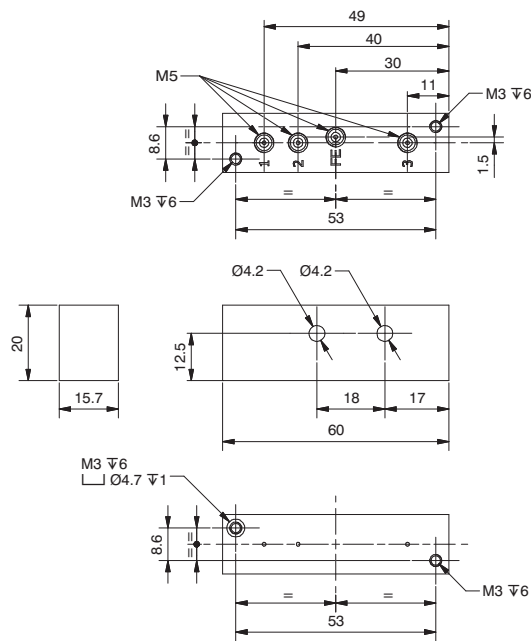

Ordering code	
<b>170M1.EFV</b>	

Weight: 50 g

► Proportional Pressure Regulator c/w 4mm In-Line Single Base with External Feedback

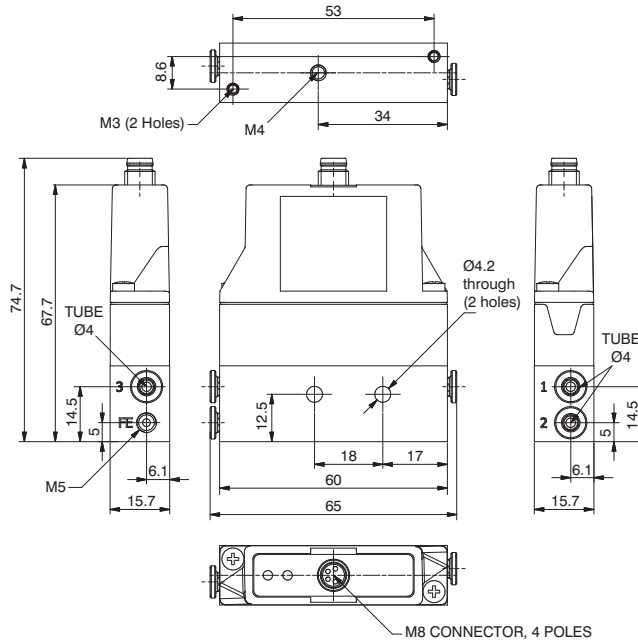

Ordering code	
<b>170EPM.V.M.⊙.ETO</b>	
PROTECTION	
<b>P</b>	0 = Parameter 18 active
	2 = Parameter 18 not active
VERSION	
<b>V</b>	T = Voltage signal
	C = Current signal
PRESSURE RANGE	
<b>⊙</b>	001 = Range 0 - 1 bar
	005 = Range 0 - 5 bar
	009 = Range 0 - 9 bar

Weight: 110 g

► Single 4mm In-Line Base with External Feedback

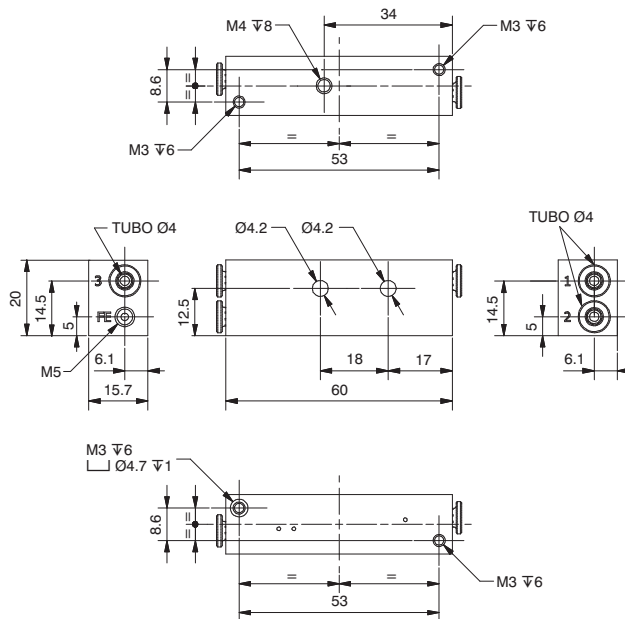

Ordering code	
<b>170M1.ETO</b>	

Weight: 50 g



2

AIR SERVICE UNITS

Proportional Pressure Regulator c/w 4mm Bottom Entry Single Base with External Feedback

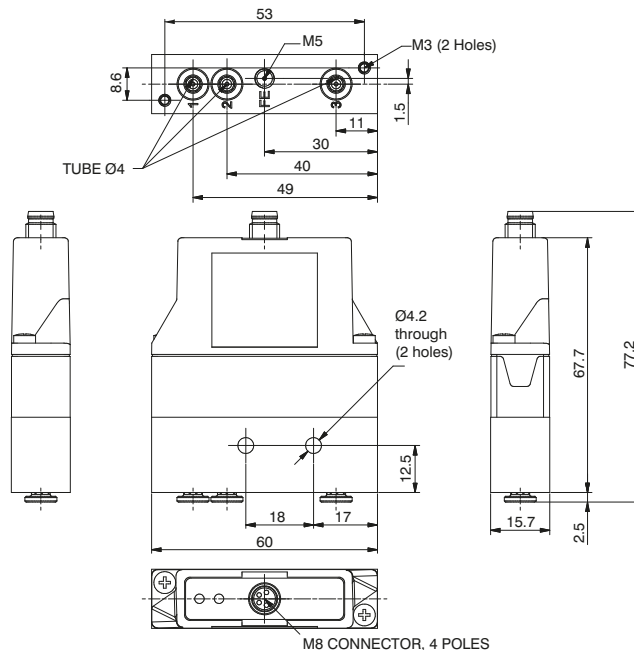

Weight: 110 g

Ordering code	
<b>170EPM.V.M.G.ETV</b>	
PROTECTION	
<b>P</b>	0 = Parameter 18 active
	2 = Parameter 18 not active
VERSION	
<b>V</b>	T = Voltage signal
	C = Current signal
PRESSURE RANGE	
<b>G</b>	001 = Range 0 - 1 bar
	005 = Range 0 - 5 bar
	009 = Range 0 - 9 bar

Single 4mm Bottom Entry Base with External Feedback

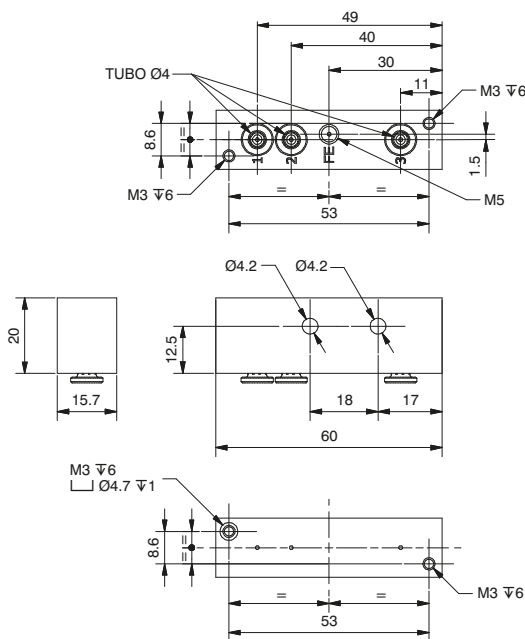

Weight: 50 g

Ordering code	
<b>170M1.ETV</b>	

### Coding For Proportional Pressure Regulator Modular Manifold

It is possible to assemble a manifold of Miniature Proportional Regulators to a maximum of 12 Regulators.  
For the coding of the Manifold, refer to the configuration Table below.

The Regulators are fed by a single supply pressure via the G1/8" connection. In the Manifold, the Pressure Regulators operate independently, the output pressure is supplied via the M5 or 4mm output connection depending on the model requested. The electrical signal is controlled via the M8 connector.

There are also configured single bases up to a maximum of 12 positions with power supplies and independent consumptions (See following pages).

G	1	7	0	-	-	-	M	-	-	-	P	-
Group	Series	Size	Parameter 18	N. Places	Control Type	Electrical connection	Pressure range	Connection	Version	Options		
			0=Eco P18 On	A=02	T=Voltage		001=0 - 1 bar	T=Tube Ø4		= Standard *		
			2=Eco P18 Off	B=03	C=Current		005=0 - 5 bar	F=M5 Thread		E= External feedback		
				C=04			009=0 - 9 bar			* no additional letter required		
				D=05								
				E=06								
				F=07								
				G=08								
				H=09								
				I=10								
				L=11								
				M=12								

Example	
Code	G1700ITM009FP
Description	10 Position Miniature Proportional Pressure Regulator, Voltage controlled with M5 Outputs

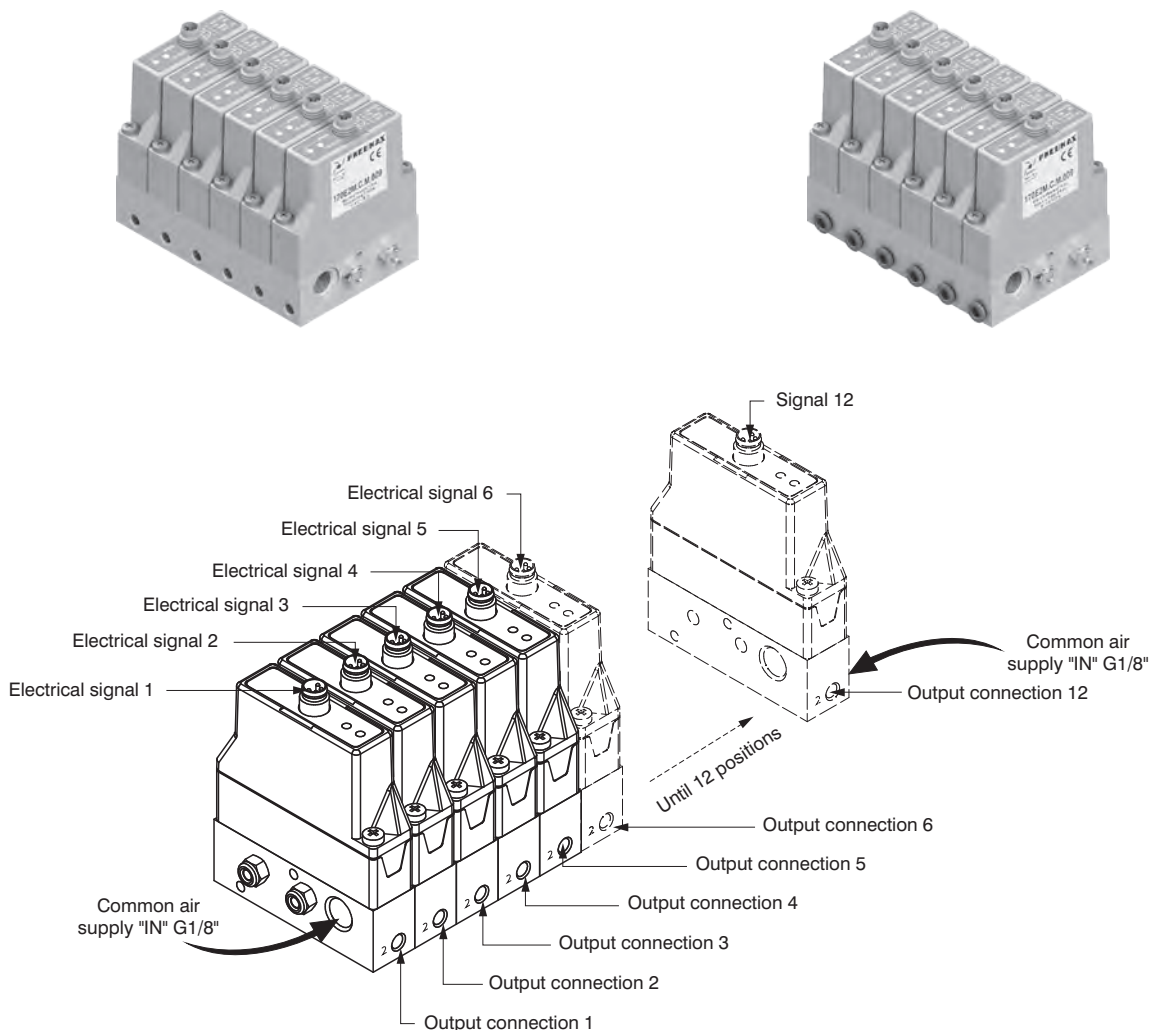

Multiple M5 In-Line Base

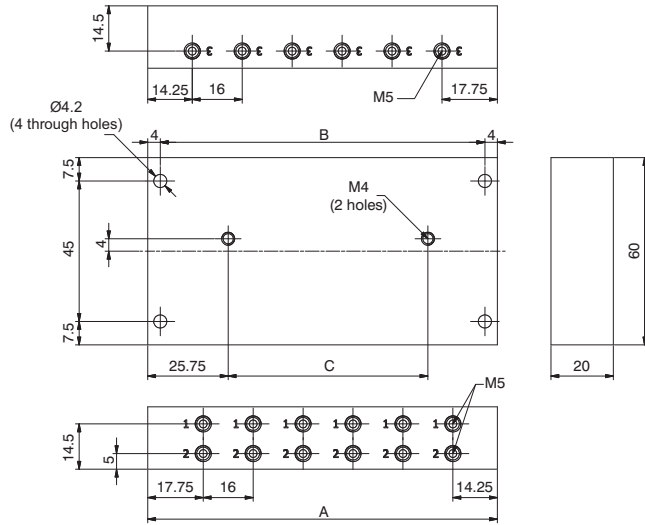
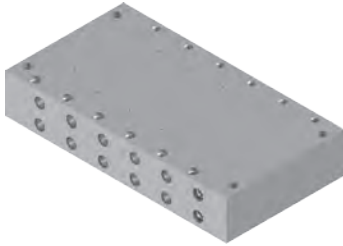

DIMEN.	N° PLACES									
	2 PLA.	3 PLA.	4 PLA.	5 PLA.	6 PLA.	7 PLA.	8 PLA.	9 PLA.	10 PLA.	
A	48	64	80	96	112	128	144	160	176	
B	40	56	72	88	104	120	136	152	168	
C	0	16	32	48	64	80	96	112	128	

Ordering code	
<b>170M<math>\emptyset</math>.FO</b>	
N. PLACES	
2=2 places (weight gr.100)	
3=3 places (weight gr.150)	
4=4 places (weight gr.200)	
5=5 places (weight gr.250)	
6=6 places (weight gr.300)	
7=7 places (weight gr.350)	
8=8 places (weight gr.400)	
9=9 places (weight gr.450)	
10=10 places (weight gr. 500)	

Multiple M5 Bottom Entry Base

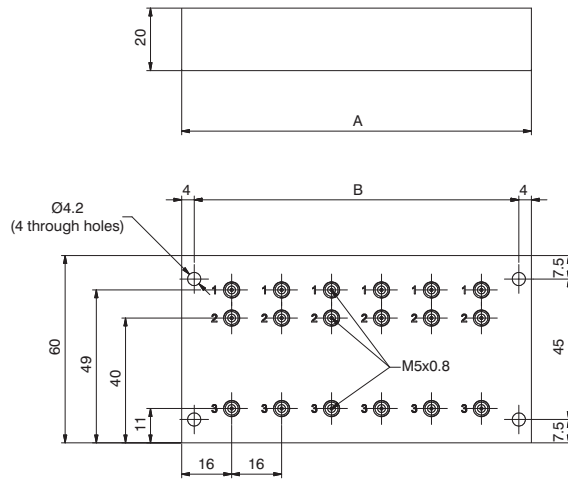

DIMEN.	N° PLACES									
	2 PLA.	3 PLA.	4 PLA.	5 PLA.	6 PLA.	7 PLA.	8 PLA.	9 PLA.	10 PLA.	
A	48	64	80	96	112	128	144	160	176	
B	40	56	72	88	104	120	136	152	168	

Ordering code	
<b>170M<math>\emptyset</math>.FV</b>	
N. PLACES	
2=2 places (weight gr.100)	
3=3 places (weight gr.150)	
4=4 places (weight gr.200)	
5=5 places (weight gr.250)	
6=6 places (weight gr.300)	
7=7 places (weight gr.350)	
8=8 places (weight gr.400)	
9=9 places (weight gr.450)	
10=10 places (weight gr. 500)	



### Multiple M5 In-Line Base with External Feedback

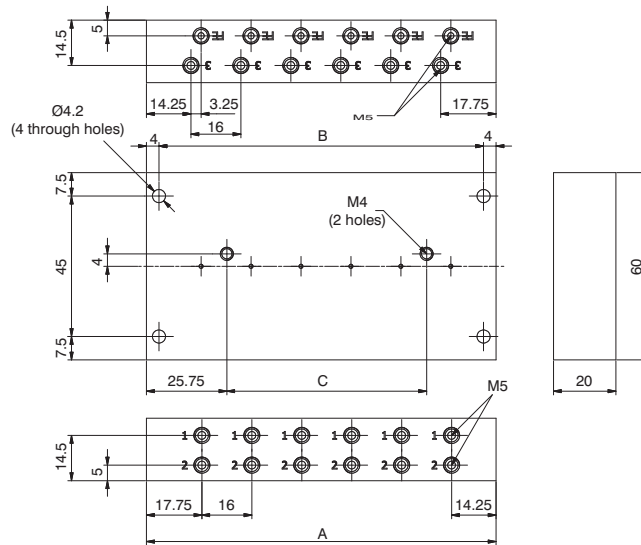

DIMEN.	N° PLACES									
	2 PLA.	3 PLA.	4 PLA.	5 PLA.	6 PLA.	7 PLA.	8 PLA.	9 PLA.	10 PLA.	
A	48	64	80	96	112	128	144	160	176	
B	40	56	72	88	104	120	136	152	168	
C	0	16	32	48	64	80	96	112	128	

Ordering code	<b>170M<sup>N</sup>.EFO</b>
N. PLACES	2=2 places (weight gr.100)
	3=3 places (weight gr.150)
	4=4 places (weight gr.200)
	5=5 places (weight gr.250)
	6=6 places (weight gr.300)
	7=7 places (weight gr.350)
	8=8 places (weight gr.400)
	9=9 places (weight gr.450)
	10=10 places (weight gr. 500)

### Multiple M5 Bottom Entry Base with External Feedback

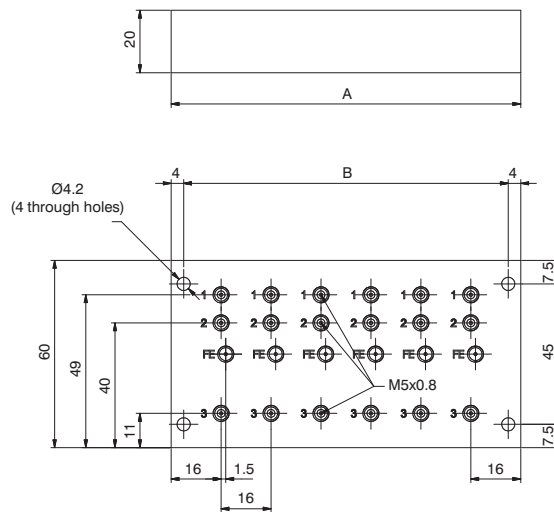
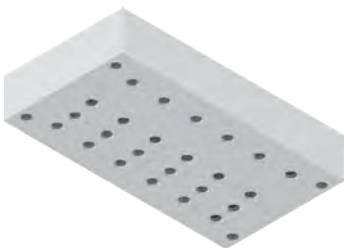

DIMEN.	N° PLACES									
	2 PLA.	3 PLA.	4 PLA.	5 PLA.	6 PLA.	7 PLA.	8 PLA.	9 PLA.	10 PLA.	
A	48	64	80	96	112	128	144	160	176	
B	40	56	72	88	104	120	136	152	168	

Ordering code	<b>170M<sup>N</sup>.EFV</b>
N. PLACES	2=2 places (weight gr.100)
	3=3 places (weight gr.150)
	4=4 places (weight gr.200)
	5=5 places (weight gr.250)
	6=6 places (weight gr.300)
	7=7 places (weight gr.350)
	8=8 places (weight gr.400)
	9=9 places (weight gr.450)
	10=10 places (weight gr. 500)

### Clip

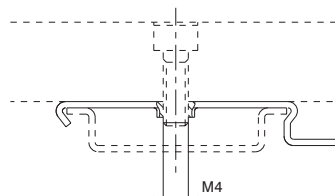

Ordering code	<b>800.00</b>
---------------	---------------

Weight g 5

2 AIR SERVICE UNITS

Mini digital pressure switch

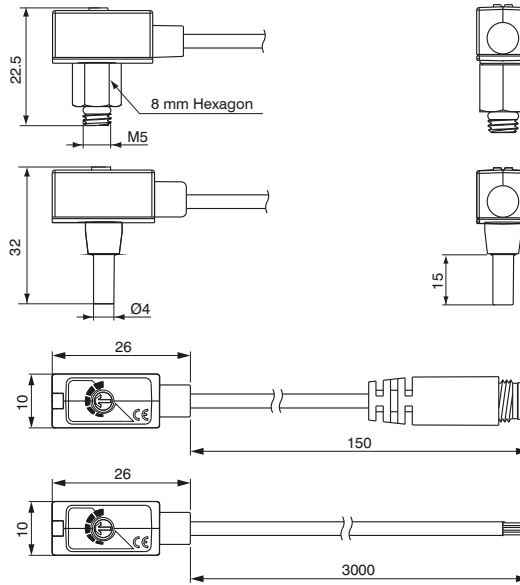

Ordering code	
<b>DS.10.P.B.C.L.O</b>	
CONNECTION	
<b>C</b>	F4=Male M5
	R4=Plug-in connection Ø4
CABLE LENGTH	
<b>L</b>	A=150 mm *
	E=3000 mm **
OPTIONS	
<b>O</b>	0=Without connector
	1=With connector M8 male 3 Pin

\* only with M8 connector  
\*\* only without connector

2 AIR SERVICE UNITS

Technical features

Working pressure range	0 - 0.6 mPa
Regulation pressure range	0 - 0.6 mPa
Maximum supported pressure	1.5 mPa
Allowed fluids	Air, non-corrosive gases, non-combustible gases
Supply voltage	From 12 to 30 VDC ±10%
Current consumption	≤ 10mA
Digital output	PNP N.O. 1 outputs Maximum load current: 80mA Maximum supply voltage: 30VDC Voltage drop: ≤0.8V
Repeatability (Digital output)	± 1% Full Scale
Digital output	Type of hysteresis: fixed Hysteresis: 3% Full Scale max.
Response time	1ms
Protection from short circuit at output	Present
Method of setting threshold	Adjustable, trimmer
Indicator	LED red (output)
Ingress protection rating	Protection class: IP40 Ambient temperature: Operational: 0 - 60°C, Storage: -20 - 70°C (without ice or condensation) Ambient humidity: Operational/Storage: 35 - 85% (without condensation) Vibration: Total amplitude 1.5mm., 10Hz-55Hz-10Hz scanning for 1 minute, 2 hours in each direction of X, Y and Z Impacts/shocks: 980m/s <sup>2</sup> (100G), 3 times in each direction of X, Y and Z
Temperature characteristics	±2% Full Scale in a range between 0 - 50°C
Type of connection	Male M5x0.8, Plug-in connection Ø4
Electrical cable	Oilproof cable, 3 wires (0.18mm <sup>2</sup> ), Ø2.6mm
Weight	Approximately 50 gr. (with 3 metres of cable)

Output circuit wiring scheme

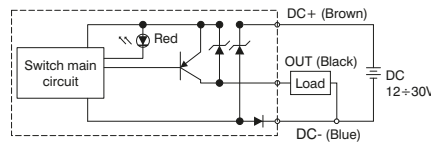

Panel-mounted digital pressure switch

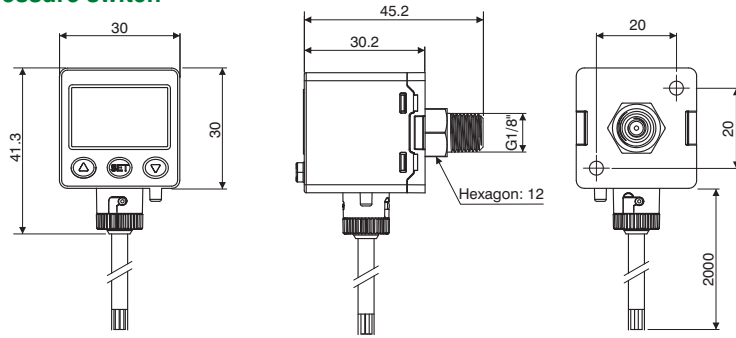

Ordering code	
<b>DS.45.P.U.F3.D.0</b>	
OUTPUTS	
<b>U</b>	E=2 PNP outputs + Analog output (4 / 20 mA)
	L=2 PNP outputs + copy function

Technical features

Working pressure range	0.000 - 1.000 mPa	
Regulation pressure range	-0.100 - 1.000 mPa	
Maximum supported pressure	1.5 mPa	
Allowed fluids	Air, non-corrosive gases, non-combustible gases	
Pressure calibration sensitivity	kPa	0.1
	kgf/cm <sup>2</sup>	0.001
	bar	0.001
	psi	0.01
	InHg	0.1
Supply voltage	From 12 to 24 VDC	
Current consumption	≤40mA (without load)	
	PNP N.O. 2 outputs Maximum load current: 125mA Maximum supply voltage: 24VDC Voltage drop: ≤1.5V	
Digital output	± 0.2% Full Scale ± 1 digit	
Repeatability (Digital output)	Settable	
Digital output	Type of hysteresis Hysteresis	from 0.001 to 0.008 bar
Response time	≤2,5 ms (anti-interference function: 25ms, 100ms, 250ms, 500ms, 1000ms and 1500ms selectable)	
Protection from short circuit at output	Present	
Display	Display with 3 1/2 digits (red/Green)	
Indicator precision	±2% F. S. ±1 digit	
Indicator	LED Orange (output1) LED Orange (output2)	
Analog output	Output current: 4÷20mA ±2.5% F. S. Linearity: ±1% F. S.	
	Maximum load resistance: 250Ω supply at 12V and 600Ω supply at 24V Minimum load resistance: 50Ω	
	IP65	
Ingress protection rating	Protection class	IP65
	Ambient temperature	Operational: 0 - 50°C, Storage: -10 - 60°C (without ice or condensation)
	Ambient humidity	Operation/Storage: 35 - 85% (without condensation)
	Supported voltage	1000VAC in 1min. (between body and cable)
	Insulation resistance	50MΩ (at 500VDC, between body and cable)
	Vibration	Total amplitude 1.5mm or 10G, 10Hz-55Hz-10Hz scanning for 1 minute, 2 hours in each direction of X, Y and Z
Temperature characteristics	Impacts/shocks	100m/s <sup>2</sup> (10G), 3 times in each direction of X, Y and Z
	Type of connection	±2.5% Full Scale in a range between 0 - 50°C
Type of connection	G1/8" (BSPP), M5 female	
Electrical cable	Oil resistant cable (internal 0.15mm <sup>2</sup> )	
Weight	Approximately 86 gr. (with 2 metres of cable)	

Output circuit wiring scheme

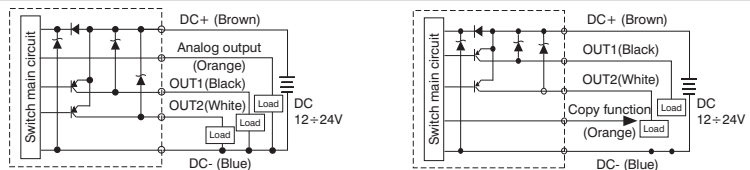

Accessories

Fastening bracket



Ordering code  
**DS.BT10**

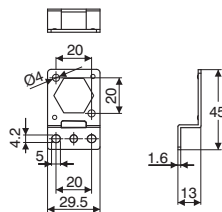

Panel mount adapter



Ordering code  
**DS.PAE**

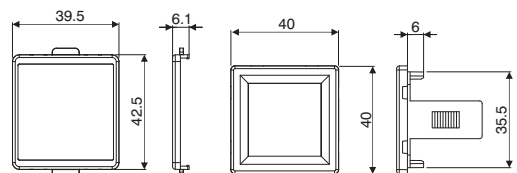

Fastening bracket



Ordering code  
**DS.BT11**

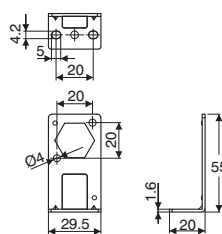

Panel mount adapter with screen protection



Ordering code  
**DS.PAF**

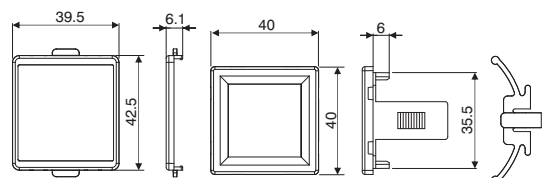

Digital battery pressure gauge

Ordering code

**DS.60.PI.F1.F.0**

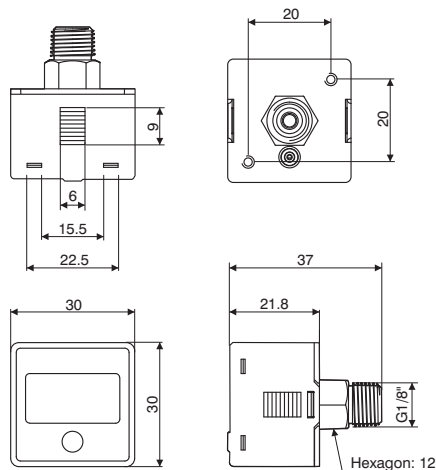

Technical features

Working pressure range	0.000 - 1.000 mPa	
Regulation pressure range	-0.100 - 1.000 mPa	
Maximum supported pressure	1.5 mPa	
Allowed fluids	Air, non-corrosive gases, non-combustible gases	
Pressure calibration sensitivity	kPa	0.1
	bar	0.01
	psi	0.1
	mmHg	1
Battery	CR 2032 lithium	
Backlight	Not present	
Battery life	3 years (5 powerups a day)	
Indication of battery level	Present	
Battery replaceable	Yes	
Display powerup time	Goes off after 60 seconds	
Sampling frequency	2 Hz (2 times per second)	
Repeatability	±1% F. S. ±1 digit	
Display	Display with 3 1/2 digits	
Indicator precision	±2% F.S. ±1 digit (at ambient temperature of 25°C ±3°C)	
Ingress protection rating	Protection class	IP65 (only with connected air pipe)
	Ambient temperature	Operational: 0 - 50°C, Storage: -10 - 60°C (without ice or condensation)
	Ambient humidity	Operational/Storage 35 - 85% (without condensation)
	Vibration	Total amplitude 1.5mm or 10G, 10Hz-55Hz-10Hz scanning for 1 minute, 2 hours in each direction of X, Y and Z
Impacts/shocks	100m/s <sup>2</sup> (10G), 3 times in each direction of X, Y and Z	
Temperature characteristics	±2% Full Scale in a range between 0 - 50°C	
Type of connection	R1/8", M5 female	
Weight	Approximately 40 gr.	

Accessories

Fastening bracket



Ordering code  
**DS.BT5**

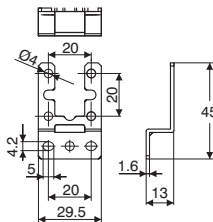

Panel mount adapter



Ordering code  
**DS.PAC**

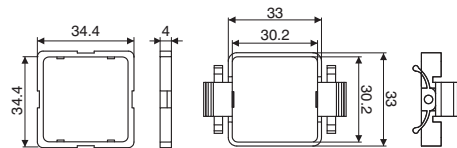

Fastening bracket



Ordering code  
**DS.BT6**

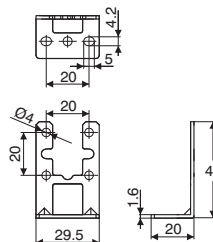

Panel mount adapter with screen protection

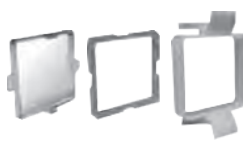

Ordering code  
**DS.PAD**

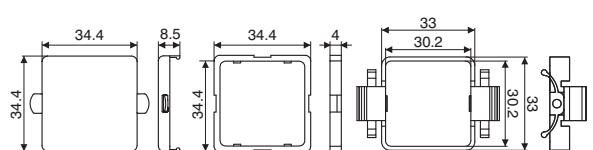

**Digital pressure gauge**

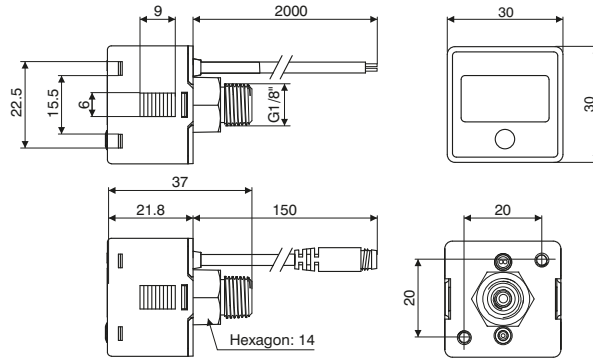

Ordering code	
<b>DS.61.PI.F1.L.⓪</b>	
CABLE LENGTH	
<b>L</b>	A=150 mm *
	D=2000 mm **
OPTIONS	
<b>⓪</b>	0=Without connector
<b>Ⓛ</b>	2=With connector M8 male 4 Pin
* only with M8 connector	
** only without connector	

**Technical features**

Working pressure range	0.000 - 1.000 mPa	
Regulation pressure range	-0.100 - 1.000 mPa	
Maximum supported pressure	1.5 mPa	
Allowed fluids	Air, non-corrosive gases, non-combustible gases	
Pressure calibration sensitivity	kPa	1
	kgf/cm <sup>2</sup>	0.01
	bar	0.01
	psi	0.1
Supply voltage	From 12 to 24 VDC ± 10%	
Current consumption	10mA	
Repeatability	± 1% Full Scale ± 1 digit	
Display	Display with 3 1/2 digits (sampling 5 times per sec.)	
Indicator precision	±2% F. S. ± 1 digit (at ambient temperature of 25°C ± 3°C)	
Ingress protection rating	Protection class	IP65 (only with connected air pipe)
	Ambient temperature	Operational: 0 - 50°C, Storage: -10 - 60°C (without ice or condensation)
	Ambient humidity	Operation/Storage: 35 - 85% (without condensation)
	Supported voltage	1000VAC in 1 min. (between body and cable)
	Insulation resistance	50MΩ (at 500VDC, between body and cable)
	Vibration	Total amplitude 1.5mm or 10G, 10Hz-55Hz-10Hz scanning for 1 minute, 2 hours in each direction of X, Y and Z
Impacts/shocks	100m/s <sup>2</sup> (10G), 3 times in each direction of X, Y and Z	
Temperature characteristics	±2% Full Scale in a range between 0 - 50°C	
Type of connection	R1/8", M5 female	
Electrical cable	Oil resistant cable (internal 0.15mm <sup>2</sup> )	
Weight	Approximately 60 gr. (with 2 metres of cable) and Approximately 40 gr. (with M8 4 pin male connector)	

**Output circuit wiring scheme**

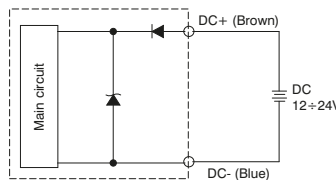

**Accessories**

**Fastening bracket**



Ordering code  
**DS.BT5**

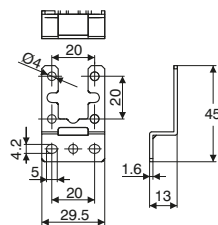

**Panel mount adapter**



Ordering code  
**DS.PAC**

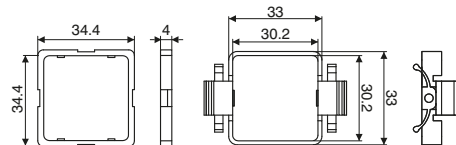

**Fastening bracket**



Ordering code  
**DS.BT6**

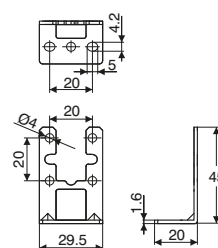

**Panel mount adapter with screen protection**

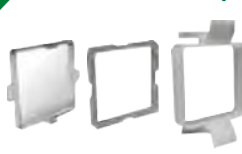

Ordering code  
**DS.PAD**

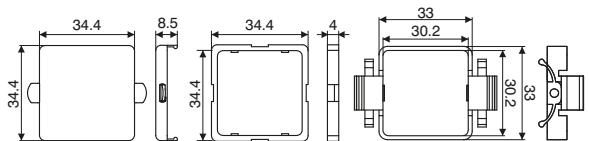

## Series 1700 - Pressure booster

### General

It is not unusual that, during some applications the thrust generated by a pneumatic cylinder is not sufficient for the specific purpose it has been designed for.

In order to get over the problem, the working pressure may be increased to a maximum line pressure which normally is 6-7 bar; alternatively the problem is solved by an higher bore cylinder that suits the machine.

Three size pressure boosters, with pressure ratio of 2 - 1, have been designed to avoid these problems. This device is utilizing the compressed air of the circuit where it is installed.

### Construction and working characteristics

The working method is based on the pump effect of the four chambers cylinder as shown in fig. 1. Two chambers are alternatively compressing the air in the boost one, while the fourth one is discharging.

By means of an internal circuit, the pressure booster keeps on pumping air till the down stream pressure reaches a value double the inlet pressure.

In these circumstances there is a balance condition.

When the down stream pressure decreases, the pressure booster starts again its alternating cycle till a new balance condition is restored.

The pressure booster can be furnished complete with pressure regulator installed on the inlet port for getting an accurate outlet pressure value. A wall mounting plate is also available.

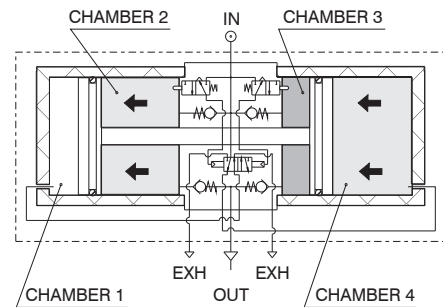

### Instructions for installation and use

It is advisable to install a small air tank after the pressure booster to avoid pressure pulsation effects.

Discharge the down stream circuit before any maintenance operation as the inner circuit of the booster does not allow the down stream line discharge even if the inlet pressure drops down.

### Maintenance

Pressure booster has an average life of about 20 millions of valve cycles, depending on working conditions (every back stroke corresponds to one valve cycles). A proper lubrication and filtration of air improve the life of pressure booster parts.

It is advisable to protect the exhaust ports in environment.

Replaceable spare seal kits are available.

### How to calculate the required time of pressure booster to increase the air pressure in a tank whose capacity is known.

Operating Data:

P1 = Inlet pressure

P2' = Tank initial pressure

P2'' = Tank final pressure

V = Tank volume

PROCEDURE :

1) Calculate the ratio K' between the initial pressure of the tank and the inlet pressure of the booster ( $P2'/P1$ ).

2) Calculate the ratio K'' between the final pressure of the tank and the inlet pressure of the booster ( $P2''/P1$ ).

3) Locate the intersection point between the ratio K' and the curve on filling time diagram related to the specific booster.

Trace a vertical line from the above point and read the correspondent time T' (the example shows the ratio K = 0.8 and correspondent time of about 4.8 seconds).

4) Repeat same procedure also for ratio K'' to get time T''.

5) Use the following formula  $T = (T'' - T')$

to obtain the total time required to move the pressure P2' to P2'' of tank volume V.

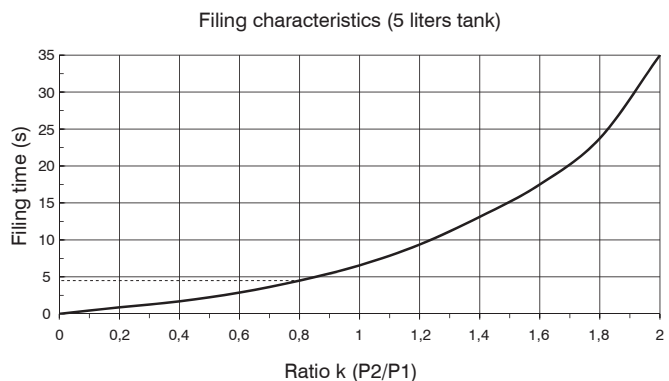

P1 = inlet pressure  
P2 = tank pressure

► Pressure booster  $\varnothing 40$

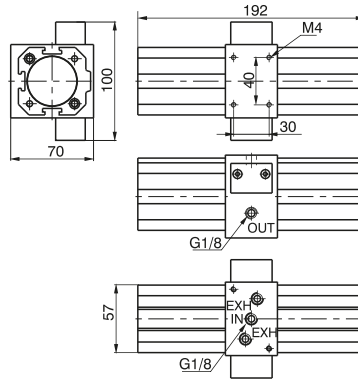
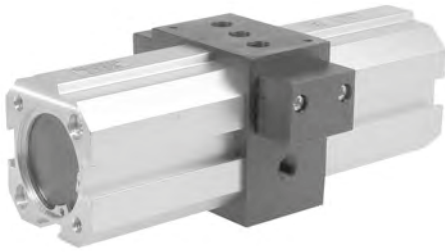

Ordering code  
**1740.50N**

Flow rate curves

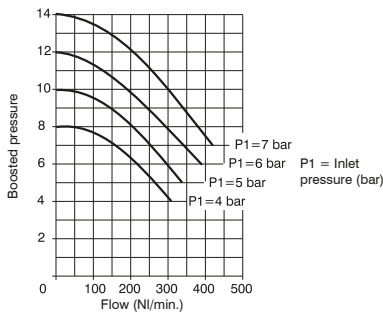

Filling curves

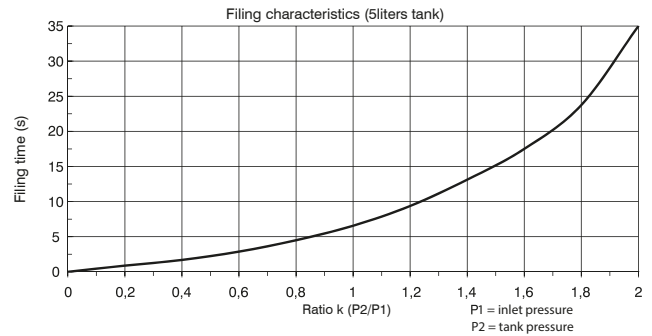

**Operating Characteristics**

- Self operating pressure booster with pressure ratio of 2:1.
- Automatic functioning: to operate the booster just connect it to compressed air line.
- Body made with light alloy.
- Barrel made of extruded and anodized aluminium.
- Downstream circuit pressure is kept under pressure even in absence of inlet pressure.

**Technical characteristics**

Connections	G 1/8"
Max working pressure (bar)	2 - 8
Temperature °C	-5 - +50
Nominal orifice diameter (mm)	$\varnothing 5$
Weight (g)	1500
Assembly position	Any
Max. fittings torque (Nm)	15

► Pressure booster  $\varnothing 40$  with pressure regulator

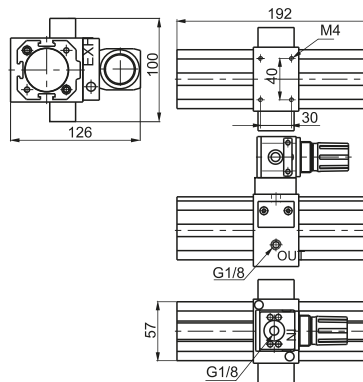
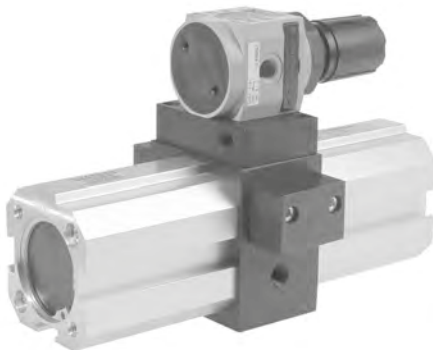

Ordering code  
**1740.50.NR**

Flow rate curves

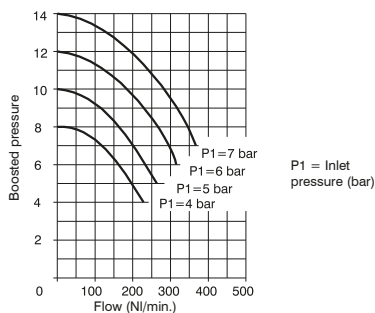

Filling curves

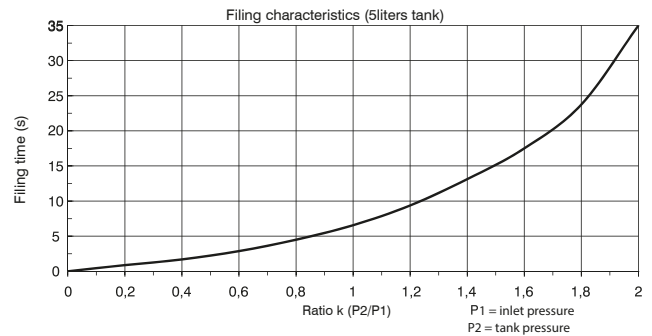

**Operating Characteristics**

- Self operating pressure booster with pressure ratio of 2:1.
- Automatic functioning: to operate the booster just connect it to compressed air line.
- Body made with light alloy.
- Barrel made of extruded and anodized aluminium.
- Downstream circuit pressure is kept under pressure even in absence of inlet pressure.
- Regulation of the inlet pressure (and as a consequence regulation of the outlet pressure)

**Technical characteristics**

Connections	G 1/8"
Max working pressure (bar)	2 - 8
Temperature °C	-5 - +50
Nominal orifice diameter (mm)	$\varnothing 5$
Weight (g)	1600
Assembly position	Any
Max. fittings torque (Nm)	15

**Pressure booster ø63**

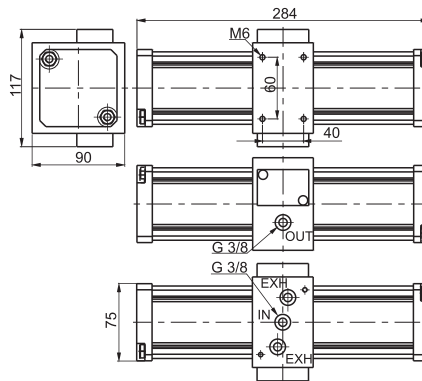

Ordering code  
**1763.80N**

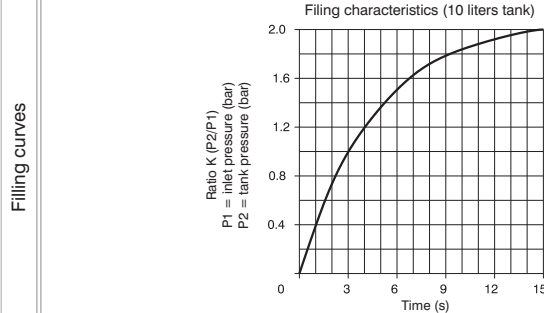
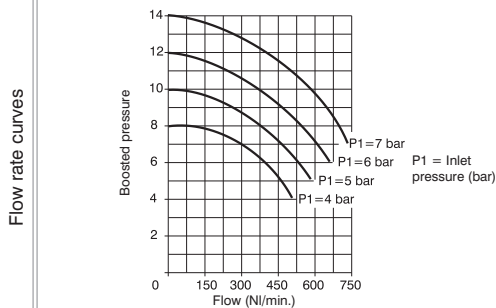

**Operating Characteristics**

- Self operating pressure booster with pressure ratio of 2:1.
- Automatic functioning: to operate the booster just connect it to compressed air line.
- Body made with light alloy.
- Barrel made of extruded and anodized aluminium.
- Downstream circuit pressure is kept under pressure even in absence of inlet pressure.

**Technical characteristics**

Connections	G3/8"
Max working pressure (bar)	2 - 8
Temperature °C	-5 - +50
Nominal orifice diamete (mm)	7
Weight (g)	3000
Assembly position	Any
Max. fittings torque (Nm)	15

**Pressure booster ø63 complete with pressure regulator**

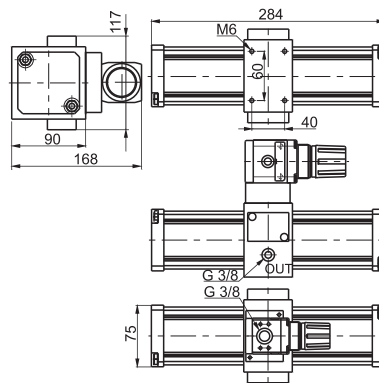

Ordering code  
**1763.80.NR**

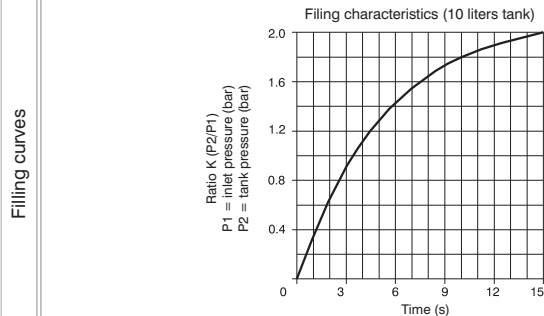
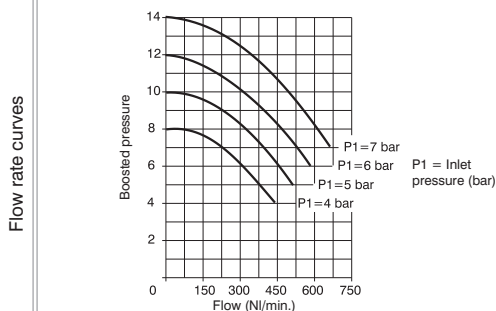

**Operating Characteristics**

- Self operating pressure booster with pressure ratio of 2:1.
- Automatic functioning: to operate the booster just connect it to compressed air line.
- Body made with light alloy.
- Barrel made of extruded and anodized aluminium.
- Downstream circuit pressure is kept under pressure even in absence of inlet pressure.
- Regulation of the inlet pressure (and as a consequence regulation of the outlet pressure)

**Technical characteristics**

Connections	G 1/8"
Max working pressure (bar)	2 - 8
Temperature °C	-5 - +50
Nominal orifice diamete (mm)	7
Weight (g)	3200
Assembly position	Any
Max. fittings torque (Nm)	15



► Pressure booster  $\varnothing 100$

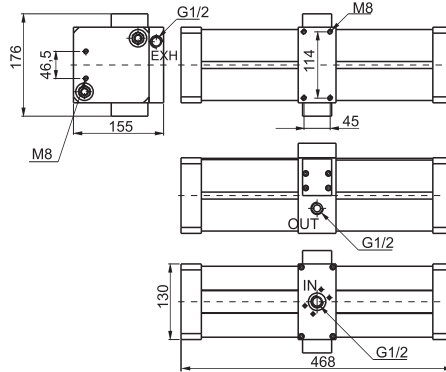

Ordering code  
**17100.125N**

Flow rate curves

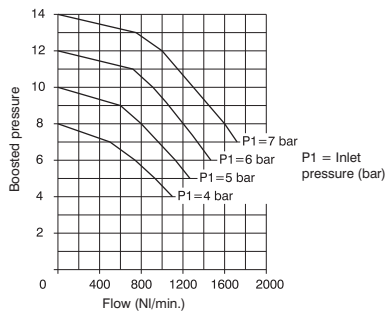

Filling curves

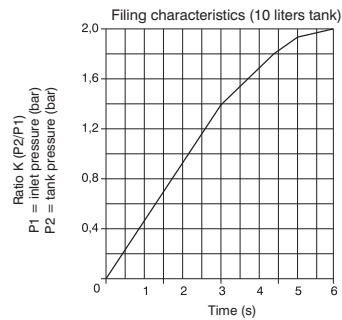

**Operating Characteristics**

- Self operating pressure booster with pressure ratio of 2:1.
- Automatic functioning: to operate the booster just connect it to compressed air line.
- Body made with light alloy.
- Barrel made of extruded and anodized aluminium.
- Downstream circuit pressure is kept under pressure even in absence of inlet pressure.

**Technical characteristics**

Connections	G1/2"
Max working pressure (bar)	2 - 8
Temperature °C	-5 - +50
Nominal orifice diamete (mm)	12
Weight (g)	12000
Assembly position	Any
Max. fittings torque (Nm)	40

► Pressure booster  $\varnothing 100$  complete with pressure regulator

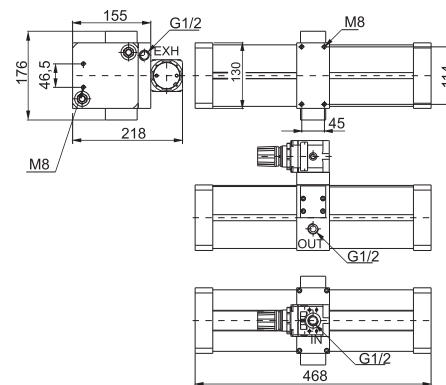

Ordering code  
**17100.125NR**

Flow rate curves

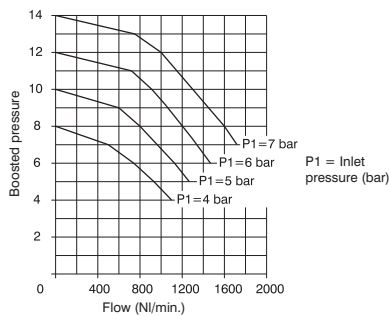

Filling curves

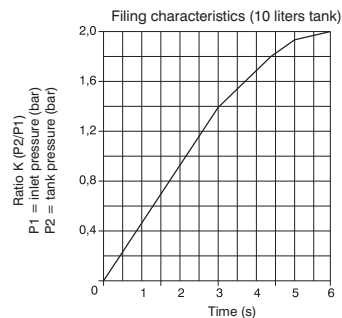

**Operating Characteristics**

- Self operating pressure booster with pressure ratio of 2:1.
- Automatic functioning: to operate the booster just connect it to compressed air line.
- Body made with light alloy.
- Barrel made of extruded and anodized aluminium.
- Downstream circuit pressure is kept under pressure even in absence of inlet pressure.
- Regulation of the inlet pressure (and as a consequence regulation of the outlet pressure)

**Technical characteristics**

Connections	G 1/2"
Max working pressure (bar)	2 - 8
Temperature °C	-5 - +50
Nominal orifice diamete (mm)	12
Weight (g)	12600
Assembly position	Any
Max. fittings torque (Nm)	40

► Base complete with pressure reducer

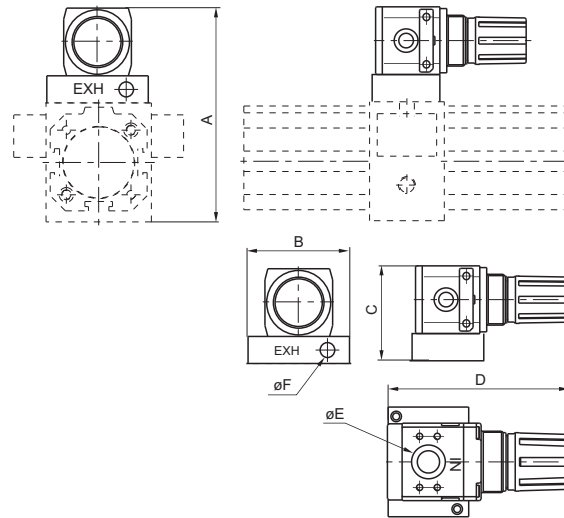

DIMENSIONS						
CODE	A	B	C	D	E	F
1740.BR	126	60	56	91	G1/8"	G1/8"
1763.BR	168	75	78	124	G3/8"	G3/8"

Ordering code
<b>17V.BR</b>
VERSION
40 = Base complete with pressure reducer for Ø40 booster
✓ 63 = Base complete with pressure reducer for Ø63 booster
ø100 = Mount directly the pressure reducer Code 17302B.C

► Booster mounting plate

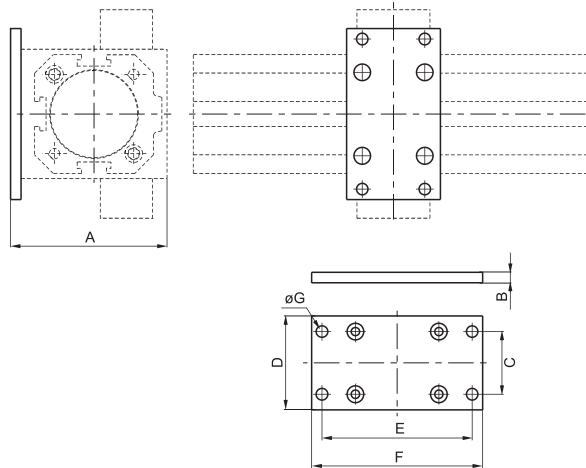

DIMENSIONS								
CODE	A	B	C	D	E	F	ØG	
1740.02	75	5	30	45	72	82	5,5	
1763.02	100	15	53	70	98"	110	M8	

Ordering code
<b>17V.02</b>
VERSION
40 = Mounting plate for Ø40 booster
✓ 63 = Mounting plate for Ø63 booster
ø100 = Use short foot bracket code 1320.50.05/1F

## Series P+

### Basic Information

In some cases the force generated by a pneumatic actuator is not sufficient to carry out its required function. To overcome this problem it is then necessary, where possible, to either increase the working pressure or use a larger bore actuator providing it will fit within the structure of the machine.

If you cannot fit a larger actuator, the solution is to use a pressure booster to increase the air pressure to that portion of the pneumatic circuit. The booster operates using the same compressed air used by the pneumatic system and does not require an external power supply. It is easy to install and can increase the working pressure in any part of the system where ever its needed, maintaining the normal working pressure in the rest of the system.

The new pressure booster **P+** is lightweight with a new compact and linear design, **P+** has an integrated pressure regulator that adjusts the setting of the output pressure P2 which is also fitted with a pressure relief valve. The design of the internal circuit provides high flow rates and fast filling times whilst the two G1/8" manometer connections built into the body of the booster allow monitoring of the input and output pressures.

### Operation

The operating principle of the device is based on a four chamber pump in which with a reciprocating movement, two chambers compress the air in the compression chamber whilst the fourth chamber is in the discharge phase. The incoming air passes through the non-return valves and supplies the compression chambers "A" and "B" at the same time.

Meanwhile, the integrated pressure regulator feeds the thrust chamber "C" via the oscillating valve which in turn compresses the air in compression chamber "B", the air is then pushed through the non-return valve and exits through the outlet connection.

When the piston reaches the end of stroke the oscillating valve changes over and feeds chamber "D" putting chamber "C" into the discharge position, thus reversing the piston and compressing the air in compression chamber "A", pushing it through the non-return valve and out through the outlet connection.

The oscillating motion of the piston allows the pressure booster to pump intensified air into the downstream circuit until the chambers reach a state of equilibrium; this in turn stops the booster.

When the downstream pressure decays the booster restarts oscillating until the state of equilibrium is re-established.

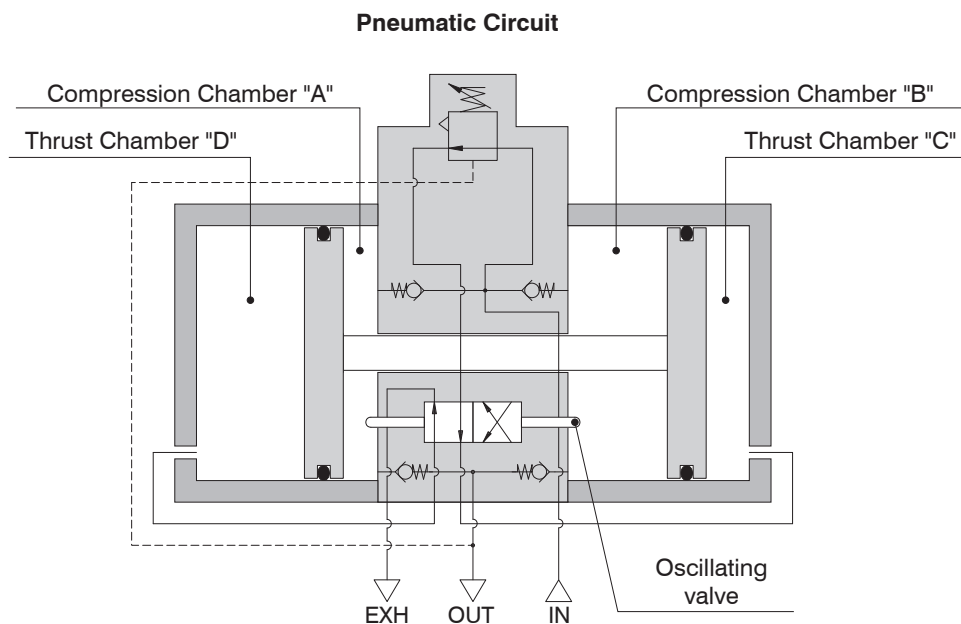

The **P+** pressure booster, is certified by ATEX:

CE II 3GD c T6 T85°C X 5°C ≤ Ta ≤ 50°C.



**General Warning**

It is recommended you follow the instructions below in order to prevent personal injury or damage to the booster.

- The pressure booster is supplied as standard with the regulating spring completely unwound. in this condition it is possible to detect a leak of air from below the regulating knob or through the exhaust port. this conditions is standard for the unit. When the spring is completely unwound the downstream pressure and the inlet pressure are the same. in order to increase the downstream pressure it is necessary to operate th regulation knob increasing the sping compression.
- Please apply the necessary safety measures to ensure that the booster only operates within the specified pressure range. Exceeding the maximum output pressure is dangerous.
- The Booster is fitted with a non-return valve on the output which prevents discharge of the downstream pressure, It is recommended that a 3/2 valve be installed in the OUT connection if it is necessary to rapidly discharge the downstream pressure.
- When the booster is not in use it is recommended that the inlet pressure is removed to let the booster stop, thus avoiding unexpected operation or malfunction.
- If there is not downstream air consumption it is possible to register a leak through the exhaust port of the unit. this condition is normal and is the consequence of the internal designed aimed at discharging any pressure building up in the unit in the rest condition.



**Use and maintenance**

The pressure booster must always be used in accordance with the operating parameters and instruction; any improper use may cause injury or malfunction. The pressure booster is not an alternative to a compressor because continuous uninterrupted operation will greatly reduce the life of the unit.

- The operating life of the device depends mainly on the operational duty cycle. Prolonged uninterrupted use without pause may reduce the operating life of the booster.
- Ensure the unit is supplied with a suitable compressed air supply, please note: appropriate filtration and lubrication may help to increase the durability of the product.
- **The input flow value must be equal or greater than double the output flow value ( $Q1/Q2 > 2$ ).**
- **Ensure that the value of the output pressure is at least 1bar higher than the input pressure ( $P2 > P1 + 1$ ).**
- To avoid pulsation of the output pressure during operation, it is recommended that an accumulation tank (reservoir) is installed in the downstream circuit.
- Protect the booster exhaust ports from the ingress of dust or debris.
- To reduce the noise generated by the unit, install silencers into the exhaust ports.
- Pressure booster has an average life of about 20 millions of valve cycles, depending on working conditions (every back stroke corresponds to one valve cycles ).

**Regolazione della pressione**

The booster is fitted with an internal pressure regulator which allows regulation of the output pressure P2 and is also fitted with pressure relief valve. For correct operation of the booster, please consider the following instructions:

- Air leaking from under the adjusting knob when the spring is decompressed is not a defect but a sign that the device is working correctly.
- In order to increase the regulated pressure, pull the knob upwards to unlock, then rotate the knob in the direction indicated by the arrow (+).
- To lock the knob after the adjustment has been made, push the knob downwards until it detents in the locked position.
- To reduce the output pressure, pull the knob upwards, rotate the knob indicated by the arrow (-), the built in pressure relief valve will discharge the excess pressure from under the adjusting knob.
- Always regulate the rising pressure.



## Method of calculation of the time necessary to increase the pressure in a tank of a given volume using a pressure booster.

### DATA:

P1 = Inlet pressure  
P2' = Initial tank pressure  
P2'' = Final tank pressure  
V = Tank volume

### PROCEDURE:

- 1) Calculate the K' ratio between the initial tank pressure and the inlet booster pressure (P2'/P1).
- 2) Calculate the K'' ratio between the final tank pressure and the inlet booster pressure (P2''/P1).
- 3) Locate, on the chart illustrating, the booster filling time, the intersection point between the K' ratio and the curve, then trace a vertical line from the intersection point to the vertical axis and read the correspondent value T' (in the example chart, to a ratio of 0.8 corresponds a time value of about 3.6 seconds).
- 4) Repeat the operation for the K'' ratio, obtaining the T'' time.

$$5) \text{ Apply the formula } T = \frac{V}{5} \cdot (T'' - T')$$

to obtain the total time needed to take the tank of volume V from the pressure value P2' to the pressure value P2''.

Example of calculation of the necessary time to take a 10L tank from the pressure value P2' to the value P2''

K' = 0,8      T' = 3,6 sec.      V = 5L.  
K'' = 1,5      T'' = 12 sec.

$$T = \frac{5}{5} \cdot (12 - 3,6) = 8,4 \text{ sec.}$$

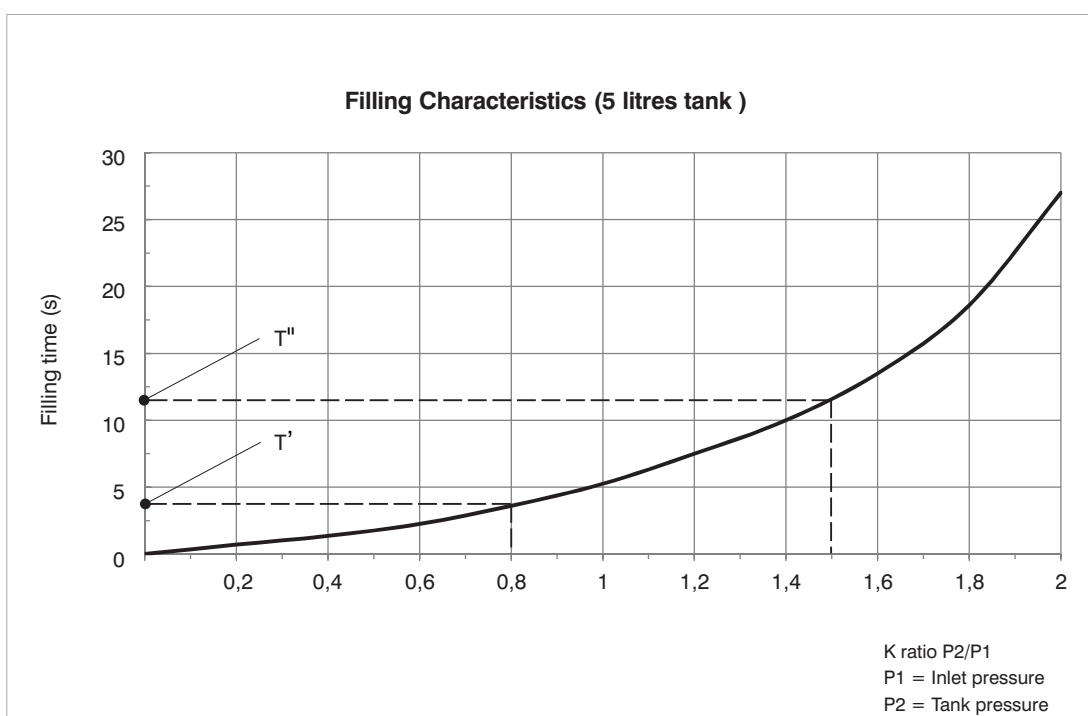

**Pressure booster in Technopolymer Ø40**

ATEX CE II 3GD

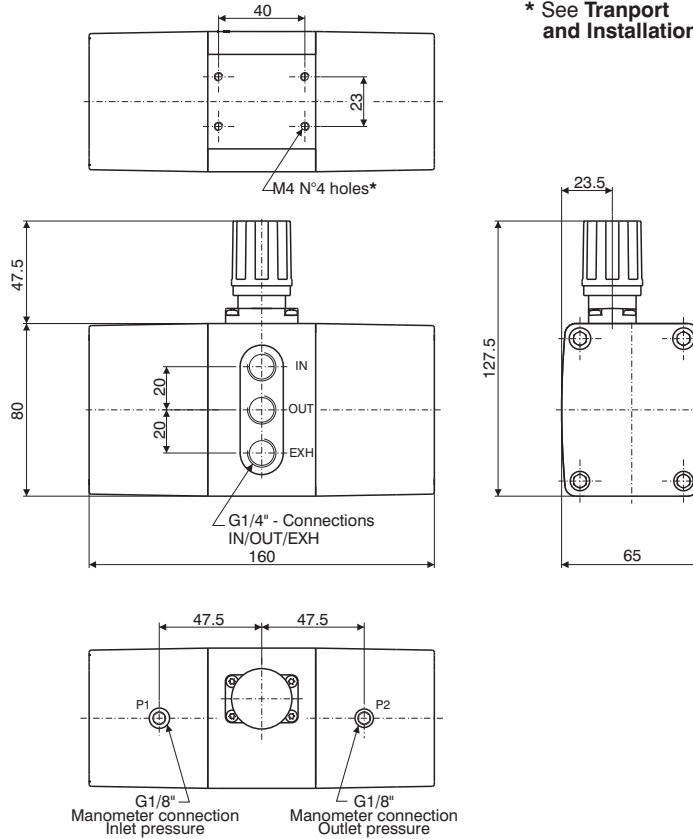
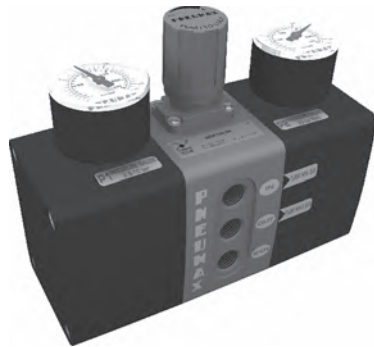

\* See Transport and Installation

Ordering code	<b>MDPT40.2R.⊙</b>
MANOMETER OPTIONS	Without options = Standard without manometer
⊙	A = Manometer P1 0-12 bar Manometer P2 0-20 bar
	B = Manometer P1 0-12 bar Manometer P2 0-16 bar
	C = Manometer P1 0-12 bar Manometer P2 0-12 bar

2  
AIR SERVICE UNITS

**Operational characteristics**

- Pressure Booster with max. 2:1 Compression ratio
- Automatic operation for use with compressed air only
- Maintains downstream air when the supply pressure fails (Providing the circuit has no leakage)
- Integrated regulator for output pressure control, with overpressure relief valve
- IN,OUT and EXH connections – G1/4" on the same side
- Manometer connections G1/8" to monitor and control the input and output pressures
- Body and cover in technopolymer
- Connections in technopolymer

**Technical characteristics**

Connections ( IN / OUT / EXT )	G1/4"
Manometer connections P1/P2	G1/8"
Working pressure ( bar ) [ Min. - Max. ]	2,5 ÷ 10
Working temperature ( °C ) [ Min. - Max. ]	-5 ÷ + 50
Multiplication ratio max.	2 : 1
Assembly position	Any
Pressure regulation	Manual with relieving
Weight	905 gr.
Max. fittings torque	G1/8 = 4 N/m G1/4 = 9 N/m

**Characteristics curves**

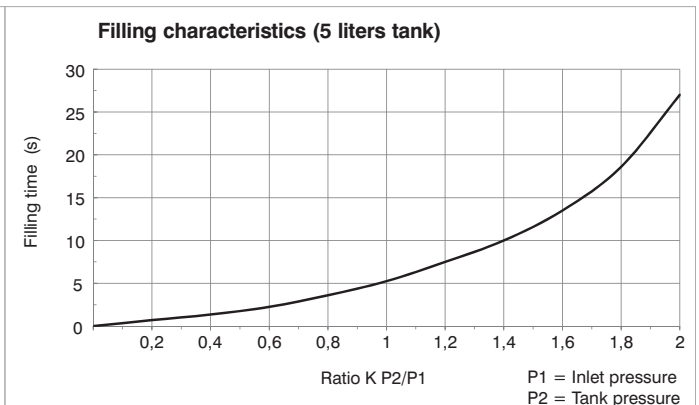
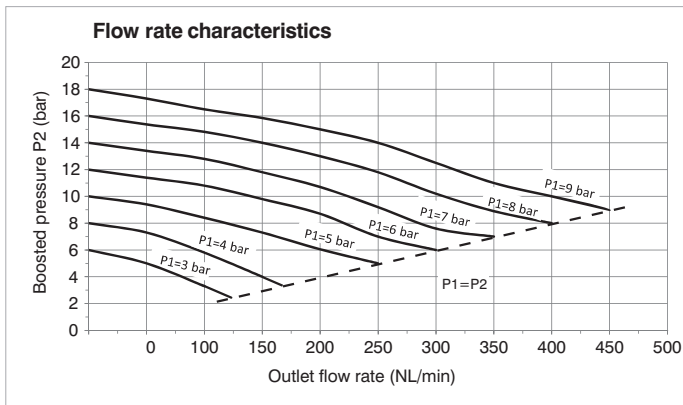

### Transport and Installation:

The installation and implementation of the device must be done by skilled personnel. Respecting the safety requirements specified in the UNI norm **UNI EN 983-97 Machinery Safety – Safety Requirements concerning oleo-hydraulic and pneumatic systems** and their components.

The following instructions are essential for a correct installation:

- Do not use the green knob to lift and transport the device, because it could rip off causing injuries or damaging objects..
- Install the booster by fixing it through the threaded M4 holes on the body of the machine or using the special accessories (see the "Accessories" chapter).

#### Direct Wall Fixing

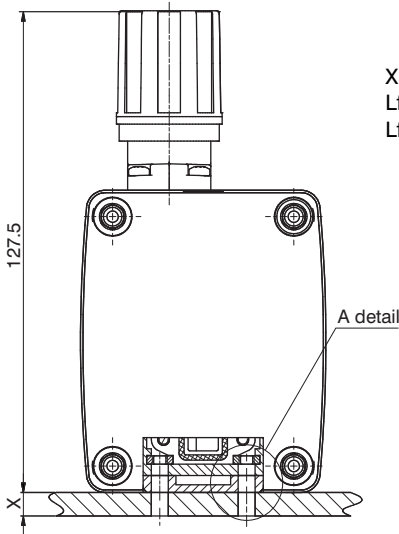

X = Thickness of the support surface  
Lf = Fixing screw thread length  
Lf = X + 10

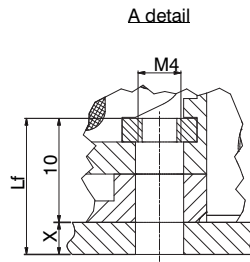

#### Fixing with a steel plate fixing clamp.

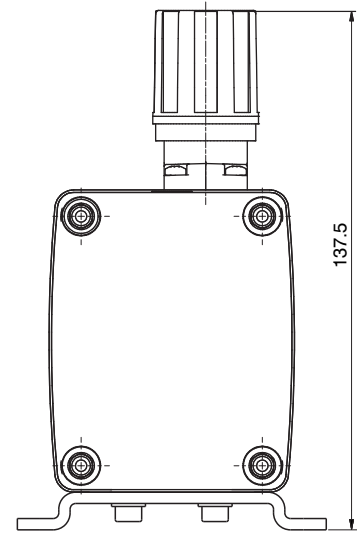

2

AIR SERVICE UNITS

### Bracket



Weight gr. 94,5  
Complete with booster fixing screws

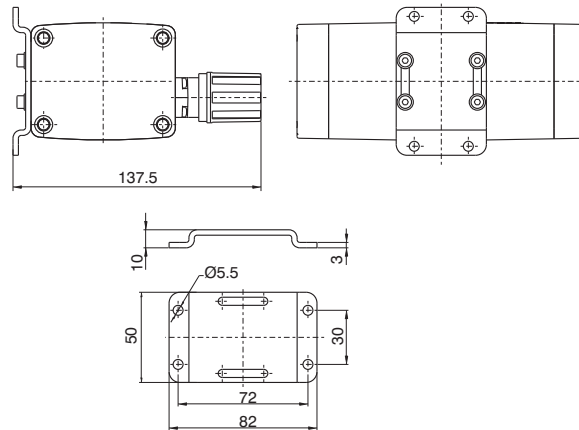

Ordering code

**T1740.01**

### Manometer D.40



Weight gr. 85

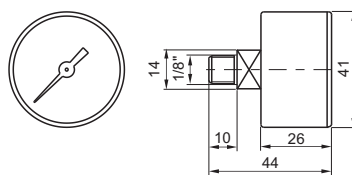

Ordering code

**17070A.S**

SCALE

A = 0-4 bar

B = 0-6 bar

C = 0-12 bar

D = 0-16 bar

E = 0-20 bar

Section 03





# Pneumatic actuation

## Pneumatic cylinders, handling and magnetic sensors

### Cylinders with piston rod according to standard

#### ISO 6432 Microbore cylinders

Versions available: with threaded end caps, rolled end caps, aluminium, stainless steel and technopolymer versions

	<b>Series 1200 Threaded end caps cylinders</b>	<b>3.1</b>		<b>Series 1200 TECNO-MIR</b>	<b>3.10</b>
	<b>Series 1200 Rolled end caps (MIR)</b>	<b>3.4</b>		<b>Series 1200 Steel line</b>	<b>3.12</b>
	<b>Series 1200 Rolled end caps (MIR-INOX)</b>	<b>3.8</b>			

#### CNOMO-CETOP-ISO cylinders

Cylinders manufactured according to standards CNOMO, CETOP and ISO: standard versions, through rod versions, tandem push with common rod, tandem push with independent rods or opposed tandem with common rod

	<b>Series 1303-1304-1305-1306-1307</b>	<b>3.30</b>
---	--	-------------

#### ISO 15552 cylinders

Cylinders according to ISO 15552 with bores from Ø32 to Ø200 mm and strokes up to 1250 mm.

Available versions: ECOPLUS with aluminium or technopolymer end plates, ECOLIGHT optimized in weight and dimensions, Steel line completely in stainless steel, round tube versions tie rod (Ø250-Ø320 mm)

	<b>Series 1319-1320-1321</b>	<b>3.40</b>		<b>Series Ecolight</b>	<b>3.50</b>
	<b>Series 1348-1349-1350</b>	<b>3.43</b>		<b>Series 1315 Round tube</b>	<b>3.68</b>
	<b>Series Ecoplus</b>	<b>3.46</b>		<b>Series Steel line</b>	<b>3.71</b>

#### ISO 15552 Hydro-pneumatic speed control cylinders

ISO 15552 Hydro-pneumatic speed control cylinders with internal hydraulic circuit for movement control

	<b>Series 1450-1463</b>	<b>3.81</b>
---	-------------------------	-------------





## ISO 21287 Compact cylinders

Compact cylinders according to standard ISO with integrated slots suitable for sensors mounting without adaptors. Bores from Ø20 to Ø100 mm. Versions with end stroke adjustable pneumatic cushioning are also available according to ISO 21287

	<b>Series Ecompact</b>	<b>3.87</b>
---	------------------------	-------------

## Cylinders with piston rod not according to standard

### Threaded body microbore cylinders

Special performance microbore cylinders with hexagonal or round bodied and either fully threaded or threaded with a plain rod ending

	<b>Series 1200 Special performance (1213-1273)</b>	<b>3.103</b>
---	--	--------------

### Non rotating cylinders

Non rotating cylinders twin rod version, available with bores from Ø32 to Ø100 mm, and strokes up to 500 mm

	<b>Series 1325-1326-1345-1347</b>	<b>3.105</b>
---	-----------------------------------	--------------

### Flat cylinders

ECOFLAT cylinders available with sizes from Ø25 to Ø63 mm and strokes up to 300 mm. Profiled tube has two "T" slots on the side hosting sensors 1580.\_, MRS.\_, MHS.\_, without adaptors. Two additional connections are also available on rear cover for cylinder feeding

	<b>Series ECOFLAT</b>	<b>3.108</b>
---	-----------------------	--------------

### Hydraulic speed control cylinders

Hydraulic speed control cylinders with outward, inward and outward/inward control, with lateral or in-line tank. Available with SKIP valve (accelerating device) and blocking valve (STOP).

	<b>Series 1400</b>	<b>3.115</b>
---	--------------------	--------------

### Short stroke & compact cylinders

Short stroke & compact cylinders with bores from Ø20 to Ø100 mm, available in single and double acting versions, tandem and through rod with magnetic piston versions. The Europe versions are mainly compliant with the ISO or UNITOP standard (relating to holes), while the Ecompact-S versions are based on connecting rods and centering diameters according to the ISO 15552 standard

	<b>Series 1500</b>	<b>3.127</b>
---	--------------------	--------------

	<b>Series Ecompact-S</b>	<b>3.144</b>
--	--------------------------	--------------

	<b>Series Europe</b>	<b>3.136</b>
---	----------------------	--------------

## Cylinders with Piston rod not according to standard (following)

### Multimount cylinders

Multimount cylinders available with bores from Ø10 to Ø25 mm, with strokes up to 50 mm and with magnetic piston versions



**Series 6500**

**3.149**

### Guided compact cylinders

These cylinders are available in sizes Ø32 to Ø63 mm, and comprise a single compact cylinder with integral guide rods. The rod guide is available in two styles: self-lubricating bronze bushes and bearing bushes



**Series 6100-6101-6110**

**3.152**

### Slide cylinders

Slide cylinders manufactured with bores from Ø8 to Ø25 mm, with strokes up to 150 mm. Available with simple and double regulation end stroke and also with front and rear shock absorber



**Series 6600**

**3.168**

### Slide units

Twin-rod linear guide units with bores from Ø10 to Ø32 mm, and with control unit with bronze bush versions, with control unit with bearing bush versions. Are also available the through twin-rod slide units and the compact slide units



**Series 6200**

**3.178**



**Series 6700**

**3.189**



**Series 6210**

**3.184**

## Rodless cylinders

### Mechanically coupled

Mechanically coupled cylinders with bore from Ø16 to Ø63 mm, and strokes up to 6000 mm, available also with linear control unit



**Series 1605**

**3.196**



**Series 1600 Ø16**

**3.207**

### Cable driven

Cable driven cylinders work in a linear translation systems



**Series 1601**

**3.212**



## Rotary actuators

### Rack & pinion rotary actuators

Double or single rack & pinion rotary actuators

	<b>Series 1330</b>	<b>3.213</b>
	<b>Series 6400</b>	<b>3.217</b>

	<b>Series 6411</b>	<b>3.221</b>
--	--------------------	--------------

### Vane type rotary actuators

Vane type rotary actuator with the shaft that runs into ball bearings, available with sizes from Ø10 to Ø100 mm

	<b>Series 6420</b>	<b>3.225</b>
---	--------------------	--------------

## Handling

### Pneumatic grippers

Pneumatic grippers manufactured with 2 angular fingers (from -10° to +30°), wide opening 180° or 3 finger parallel style

	<b>Series 6301</b>	<b>3.236</b>
	<b>Series 6302</b>	<b>3.239</b>
	<b>Series 6303</b>	<b>3.242</b>

	<b>Series 6310</b>	<b>3.245</b>
	<b>Series 6311</b>	<b>3.248</b>
	<b>Series 6312</b>	<b>3.251</b>

## Magnetic sensors



### Standard series



Magnetic sensors with Reed type or Hall effect

	<b>Series SA</b>	<b>3.254</b>
---	------------------	--------------

### Miniaturized series

Miniaturized series with Reed and Hall style versions, available with rectangular, square, square section CURS approved, and round section versions

	<b>Series SR</b>	<b>3.263</b>
	<b>Series SU CURS</b>	<b>3.264</b>

	<b>Series SQ</b>	<b>3.265</b>
	<b>Series ST</b>	<b>3.266</b>

## Accessories and fixing devices

---

### Piston rod lock

Piston rod lock for cylinders with bores from da Ø12 to Ø125 mm

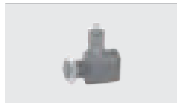

**Series 1260 - 1320**

**3.269**

---

### Linear guides

Linear control units Series 1200 (Ø20-25 mm) and Series 1320 (from Ø32 to Ø80 mm)



**Series 1260 - 1320**

**3.271**

---

### Shock absorbers

Shock absorbers with M8x1 - M10x1 - M14x1,5 - M20x1,5 - M27x1,5 threads



**Series 6900**

**3.273**

---



## Series 1200, Threaded end caps

### Construction characteristics

End caps	hard anodised aluminum
Barrel	anodised aluminium (brass for Ø8 and Ø10)
Piston rod	non magnetic piston : Ø8 - Ø10: stainless steel / Ø12 - Ø50: C43 chromed magnetic piston: Ø10 - 20: stainless steel / Ø25 - 50: C43 chromed
Piston	aluminium
Seals	Standard: NBR Oil resistant rubber, PUR Piston rod seals (HNBR or FPM seals available upon request)
Mounting	steel painted in cataphoresis
Forks	cadmium plated steel
Single-acting springs	steel for springs and stainless steel
Cushioning length	ø 16 - 20 - 25 - 32 - 40 - 50 mm 15 - 18 - 18 - 18 - 22 - 22

### Technical characteristics

Fluid	Filtered air. No lubrication needed, if applied it shall be continuous.
Max. pressure	10 bar
Working temperature	-5°C - +70°C with standard seals magnetic or non magnetic piston -5°C - +80°C with FPM seals magnetic piston -5°C - +80°C with HNBR seals magnetic piston -5°C - +120°C with HNBR seals non magnetic piston -5°C - +150°C with FPM seals non magnetic piston

Please follow the suggestions below to ensure a long life for these cylinders:

- use clean and lubricated air
- correct alignment during assembly with regard to the applied load so as to avoid radial components or bending the rod.
- avoid high speeds together with long strokes and heavy loads: this would produce kinetic energy which the cylinder cannot absorb, especially if used as a limit stop (in this case use mechanical stop device)
- evaluate the environmental characteristics of cylinder used (high temperature, hard atmosphere, dust, humidity etc.)

**Please note: air must be dried for applications with lower temperature.**

Use hydraulic oils H class (ISO VG32) for correct continued lubrication.  
Our Technical Department will be glad to help.

### Standard strokes

#### Double acting version

Ø8 - Ø10 : 15 - 25 - 50 - 75 - 80 - 100 mm

Ø12 - Ø16 : 15 - 25 - 50 - 75 - 80 - 100 - 150 - 160 - 200 - 250 - 300 mm

Ø20 - Ø25 : 15 - 25 - 50 - 75 - 80 - 100 - 150 - 160 - 200 - 250 - 300 - 320 - 350 - 400 mm

Ø32 - Ø50 : 15 - 25 - 50 - 75 - 80 - 100 - 150 - 160 - 200 - 250 - 300 - 320 - 350 - 400 - 450 - 500 mm

On request are available strokes up to:

Ø8 - Ø10 : 250 mm

Ø12 - Ø16 : 700 mm

Ø20 - Ø50 : 1000 mm

#### Single acting version

Ø12 - Ø50 : up to stroke 40 mm

On request are available strokes up to 200 mm

### Minimum and maximum springs load for single acting version

Bore	Ø12 - Ø20	Ø25	Ø32	Ø40 - Ø50
Min. load (N)	10	10	20	40
Max. load (N)	25	50	55	110

**Basic version**

Ordering code	Description
1260.Ø.stroke	Basic version
1271.Ø.stroke	Basic version front spring from Ø12 (max stroke 40 mm)
1272.Ø.stroke	Basic version rear spring from Ø12 (max stroke 40 mm)
12- -Ø.stroke.A	Adjustable cushioning (from Ø16)
12- -Ø.stroke.M	Magnetic piston (from Ø10)
12- -Ø.stroke.X	Stainless steel rod
12- -Ø.stroke.M.A	Cushioning with magnetic piston
12- -Ø.stroke.M.A.X	Cushioning, magnetic piston and stainless steel piston rod
12- -Ø.stroke. . . . T	HNBR seals version
12- -Ø.stroke. . . . V	FPM seals version

Standard execution, fully complying with ISO standards from ø 8 to ø 25. BORES 32, 40 and 50 not included in the standard, comply with our own specifications. Can use all available mountings. For single acting type, the maximum stroke is 40 mm., after which overall dimensions increase in length to an extent not proportional to the stroke (and in any case not longer than stroke 100).

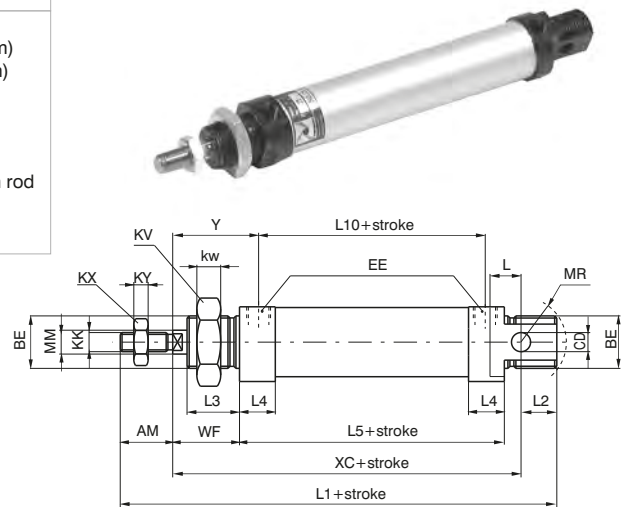
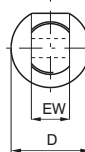

**Without rear eye version**

Ordering code	Description
1261.Ø.stroke	Without rear eye
1273.Ø.stroke	Without rear eye front spring from Ø12 (max stroke 40 mm)
1274.Ø.stroke	Without rear eye rear spring from Ø12 (max stroke 40 mm)
12- -Ø.stroke.A	Adjustable cushioning (from Ø16)
12- -Ø.stroke.M	Magnetic piston (from Ø10)
12- -Ø.stroke.X	Stainless steel rod
12- -Ø.stroke.M.A	Cushioning with magnetic piston
12- -Ø.stroke.M.A.X	Cushioning, magnetic piston and stainless steel piston rod
12- -Ø.stroke. . . . T	HNBR seals version
12- -Ø.stroke. . . . V	FPM seals
12- -Ø.stroke. . . . L	Air inlet at 90° version

Version derived from standard execution 1260 and not included in ISO standard. Not having a rear eye it is shorter and the air inlet is from the rear or at 90° like it is on the front. The considerations made for the basic type 1260 apply for all single-acting types.

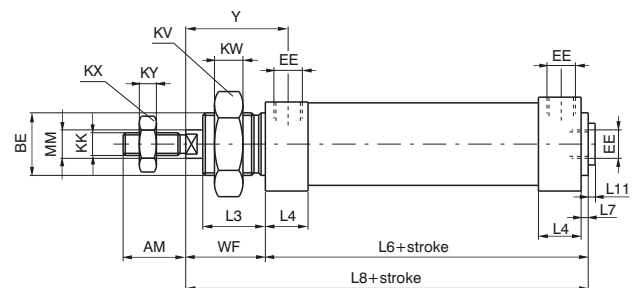

**Through rod cylinder version**

Ordering code	Description
1262.Ø.stroke	Through rod cylinder rod
1262.Ø.stroke.A	Adjustable cushioning (from Ø16)
1262.Ø.stroke.M	Magnetic piston (from Ø10)
1262.Ø.stroke.X	Stainless steel rod
1262.Ø.stroke.E	Hexagonal piston rod (from Ø12)
1262.Ø.stroke.M.A	Cushioning with magnetic piston
1262.Ø.stroke.M.A.X	Cushioning, magnetic piston and stainless steel piston rod
1262.Ø.stroke. . . . T	HNBR* seals version
1262.Ø.stroke. . . . V	FPM* seals version

\*Excludes hexagonal rod version

Execution by rod coming out from both end caps, with overall dimensions. except for the rod, equal to 1260 version. Not available with Ø8 and 10.

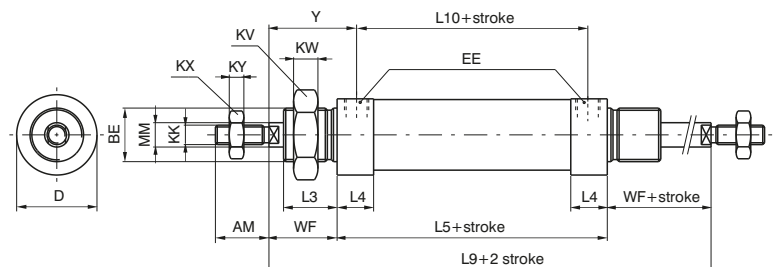



**Non rotating piston rod version**

Ordering code	Description
1260.Ø.stroke.E	Hexagonal piston rod (from Ø12)
1271.Ø.stroke.E	Hexagonal piston rod with front spring from Ø12 (max stroke 40 mm.)
1272.Ø.stroke.E	Hexagonal piston rod with rear spring from Ø12 (max stroke 40 mm.)
12--Ø.stroke.M.E	Hexagonal piston rod with magnetic piston (from Ø12)



Similar overall dimensions as 1260 basic type, it differs because of the hexagonal rod (instead of circular) to avoid the rotation. It is particularly suitable when it is used as a guide and support to the linked element. Not for use with high frequencies and long strokes. For which, whenever possible use front spring.

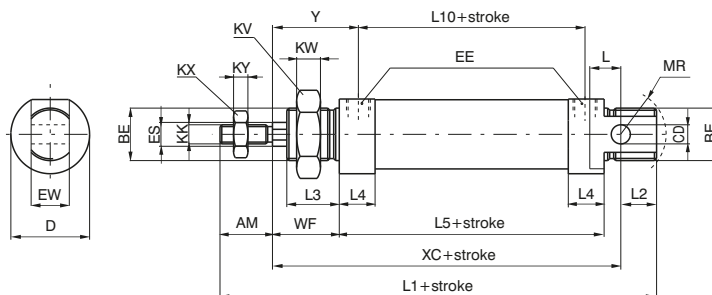

**Table of dimensions**

Bore		8	10	12	16	20	25	32	40	50
AM (-0,2)		12	12	16	16	20	22	20	25	25
BE		M12x1,25	M12x1,25	M16x1,5	M16x1,5	M22x1,5	M22x1,5	M30x1,5	M40x1,5	M40x1,5
CD (H9)		4	4	6	6	8	8	12	14	14
D (-0,3)		16	17	19	24	28	33	40	48	58
EE		M5	M5	M5	M5	G1/8"	G1/8"	G1/8"	G1/4"	G1/4"
ES		-	-	6	6	8	10	12	12	12
EW (d13)		8	8	12	12	16	16	26	30	30
KK (6g)		M4x0,7	M4x0,7	M6x1	M6x1	M8x1,25	M10x1,25	M10x1,25	M12x1,75	M12x1,75
KV		17	17	22	22	30	30	42	52	52
KW		5,5	5,5	6	6	7	7	8	9	9
KX		7	7	10	10	13	17	17	19	19
KY		3	3	4	4	5	6	6	7	7
L		6	6	9	9	12	13	13	16	16
L1(±1)	*	85	85	105	111	130	141	139	164	167
L2		9	9	14	13	15	15	14	16	16
L3		11	11	17	17	18	22	22	25	25
L4		10	10	9,5	10,5	15	15	15	18	18
L5(±1)	*	46	46	50	56	68	69	69	79	82
L6(±1)	*	48	48	52	58	70,5	71,5	71,5	82	85
L7		2	2	2	2	2,5	2,5	2,5	3	3
L8(±1)	*	64	64	74	80	94,5	99,5	99,5	117	120
L9(±1,2)	*	78	78	94	100	116	125	125	149	152
L10(±1)	*	35	35	40	45	52	53	53	60	63
L11		-	-	-	1,5	2	2	2	2	2
MM (f7)		4	4	6	6	8	10	12	14	14
MR (min.)		12	12	16	16	18	19	22	28	28
WF (±1,2)		16	16	22	22	24	28	28	35	35
XC(±1)	*	64	64	75	82	95	104	105	123	126
Y(±1,2)		21,5	21,5	27	27,5	32	36	36	44,5	44,5
STROKE TOLERANCE: until stroke 100 mm - 1,5, beyond + 2 mm.										
Weight	stroke 0	55	60	80	100	175	240	365	610	790
g	every 10mm	6	7	5	5	8	11	15	19	21

Without rear eye version

Weight	stroke 0	50	55	75	95	170	230	345	570	750
g	every 10mm	6	7	5	5	8	11	15	19	21

Through rod cylinder version

Weight	stroke 0	55	60	95	120	220	310	450	760	950
g	every 10mm	7	8	7	7	12	17	24	31	33

Hexagonal rod version

Weight	stroke 0	-	-	85	105	180	250	370	590	760
g	every 10mm	-	-	5	6	8	12	16	17	19

(\*) These dimensions increase of 10 mm for microbore cylinders equipped with magnetic piston and spring return, and of 9 mm for microbore cylinders with 10 mm BORE magnetic piston



## Series 1200, Rolled end covers "MIR"

### Construction characteristics

End caps	hard anodised aluminium
Barrel	stainless steel AISI 304
Piston rod	stainless steel
Piston	brass (ø8-10-12) aluminium (ø16-20-25)
Seals	Standard: NBR Oil resistant rubber, PUR Piston rod seals (HNBR or FPM seals available upon request)
Mounting	steel painted in cataphoresis
Forks	zinc plated steel
Single-acting springs	C98 zinc plated steel for springs
Cushioning length	ø 16 - 20 - 25 - 32 mm 15 - 18 - 18 - 18

### Operational characteristics

Fluid	Filtered air. No lubrication needed, if applied it shall be continuous.
Maximum working pressure	10 bar
Working temperature	-5°C - +70°C with standard seals magnetic or non magnetic piston -5°C - +80°C with FPM seals magnetic piston -5°C - +80°C with HNBR seals magnetic piston -5°C - +120°C with HNBR seals non magnetic piston -5°C - +150°C with FPM seals non magnetic piston

Please follow the suggestions below to ensure a long life for these cylinders:

- use clean and lubricated air
- correct alignment during assembly with regard to the applied load so as to avoid radial components or bending the rod.
- avoid high speeds together with long strokes and heavy loads: this would produce kinetic energy which the cylinder cannot absorb, especially if used as a limit stop (in this case use mechanical stop device)
- evaluate the environmental characteristics of cylinder used (high temperature, hard atmosphere, dust, humidity etc.)

**Please note: air must be dried for applications with lower temperature.**

Use hydraulic oils H class (ISO VG32) for correct continued lubrication.

Our Technical Department will be glad to help.

### Standard strokes

#### Double acting version

Ø8 - Ø10 : 15 - 25 - 50 - 75 - 80 - 100 mm

Ø12 - Ø16 : 15 - 25 - 50 - 75 - 80 - 100 - 150 - 160 - 200 - 250 - 300 mm

Ø20 - Ø25 : 15 - 25 - 50 - 75 - 80 - 100 - 150 - 160 - 200 - 250 - 300 - 320 - 350 - 400 mm

Ø32 : 15 - 25 - 50 - 75 - 80 - 100 - 150 - 160 - 200 - 250 - 300 - 320 - 350 - 400 - 450 - 500 mm

On request are available strokes up to:

Ø8 - Ø10 : 250 mm

Ø12 - Ø16 : 700 mm

Ø20 - Ø32 : 1000 mm

#### Single acting version

Front spring Ø8 - Ø32 : up to stroke 50 mm

Rear spring Ø16 - Ø32 : up to stroke 50 mm

### Minimum and maximum springs load for single acting version

Bore	Ø8	Ø10	Ø12	Ø16	Ø20	Ø25	Ø32
Min. load (N)	2.2	2.2	4	7.5	11	16.5	23
Max. load (N)	4.2	4.2	8.7	21	22	30.7	52.5



### Basic version

Ordering code	Description
<b>1280.Ø.stroke</b>	Basic version
<b>1291.Ø.stroke</b>	Basic version front spring (max stroke 50 mm)
<b>1292.Ø.stroke</b>	Basic version rear spring from Ø16 (max stroke 50 mm)
<b>12- -Ø.stroke.A</b>	Adjustable cushioning (from Ø16)
<b>12- -Ø.stroke.M</b>	Magnetic piston
<b>12- -Ø.stroke.A.M</b>	Cushioning with magnetic piston (from Ø16)
<b>12- -Ø.stroke. . . .T</b>	HNBR seals version
<b>12- -Ø.stroke. . . .V</b>	FPM seals version



Standard version, fully compliant with ISO standards. Can use all available mountings. For single acting type, the maximum stroke is 50 mm., after which overall dimensions increase in length to an extent not proportional to the stroke (and in any case not longer than stroke 100).

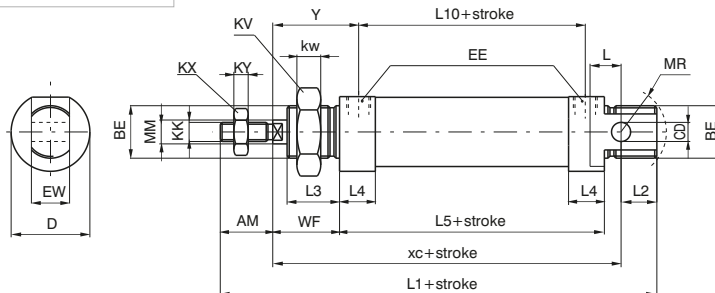

### Without rear eye version

Ordering code	Description
<b>1281.Ø.stroke</b>	Without rear eye
<b>1293.Ø.stroke</b>	Without rear eye front spring (max stroke 50 mm)
<b>1294.Ø.stroke</b>	Without rear eye rear spring from Ø16 (max stroke 50 mm)
<b>12- -Ø.stroke.A</b>	Adjustable cushioning (from Ø16)
<b>12- -Ø.stroke.M</b>	Magnetic piston
<b>12- -Ø.stroke.A.M</b>	Cushioning with magnetic piston (from Ø16)
<b>12- -Ø.stroke. . . .T</b>	HNBR seals version
<b>12- -Ø.stroke. . . .V</b>	FPM seals version



Version derived from standard version 1260 and not included in ISO standard. Not having a rear eye it is shorter. Rear inlet connection is at 90 like the front one, in line and plugged. The considerations made for the basic type 1280 apply for all single-acting types.

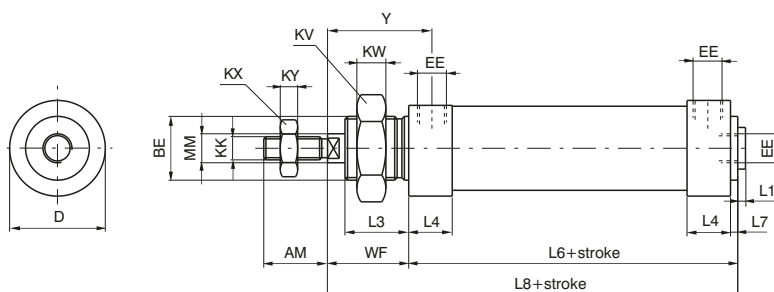

### Through rod cylinder version

Ordering code	Description
<b>1282.Ø.stroke</b>	Through rod cylinder version
<b>1282.Ø.stroke.M</b>	Magnetic piston
<b>1282.Ø.stroke.A</b>	Adjustable cushioning (from Ø16)
<b>1282.Ø.stroke.A.M</b>	Cushioning with magnetic piston (from Ø16)
<b>1282.Ø.stroke. . . .T</b>	HNBR seals version
<b>1282.Ø.stroke. . . .V</b>	FPM seals version



This version having rods coming out from both end caps with overall dimensions, except for the rod, equal to 1280 version. This version is not suitable for Ø8 and Ø10 due to difficulty in anchoring the pistons to rods.

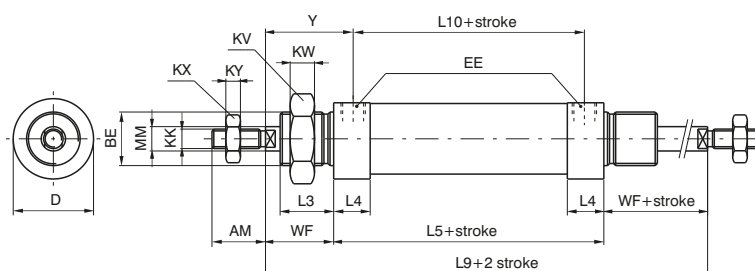

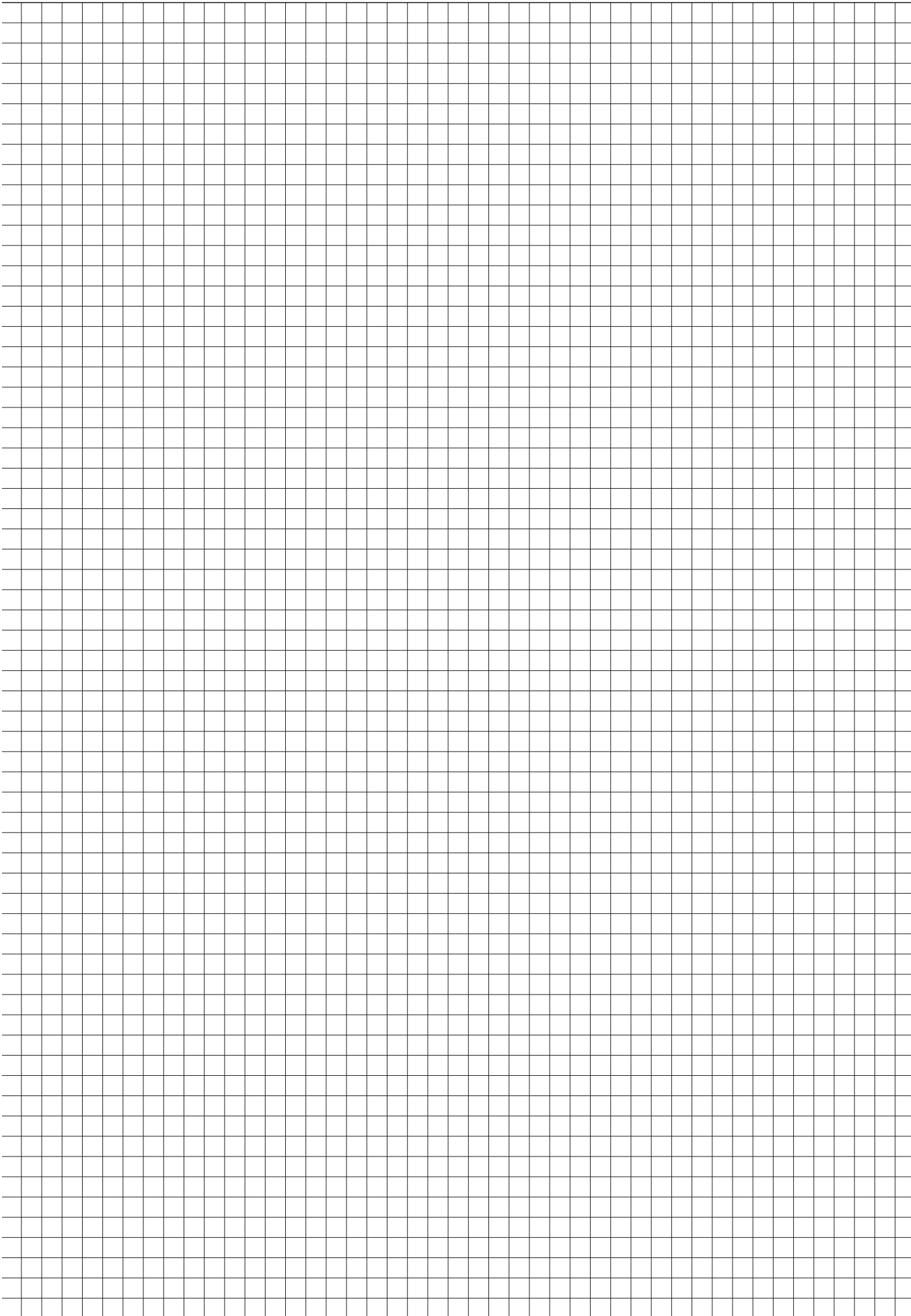

Table of dimensions

	Bore							
	8	10	12	16	20	25	32	
AM (-0,2)	12	12	16	16	20	22	20	
BE	M12X1,25	M12X1,25	M16X1,5	M16X1,5	M22X1,5	M22X1,5	M30X1,5	
CD (H9)	4	4	6	6	8	8	12	
D (h11)	16	16	20	21	27	30	38	
EE	M5	M5	M5	M5	G1/8"	G1/8"	G1/8"	
EW (d13)	8	8	12	12	16	16	26	
KK (6g)	M4X0,7	M4X0,7	M6X1	M6X1	M8X1,25	M10X1,25	M10X1,25	
KV	17	17	22	22	30	30	42	
KW	5,5	5,5	6	6	7	7	8	
KX	7	7	10	10	13	17	17	
KY	3	3	4	4	5	6	6	
L	6	6	9	9	12	13	13	
L1 (±1) *	86	86	105	111	130	141	139	
L2	10	10	14	13	15	15	14	
L3	12	12	17	17	18	22	22	
L4	9	9	9	11	15,5	15	14,5	
L5 (±1) *	46	46	50	56	68	69	69	
L6 *	48	48	52	58	70,5	71,5	71,5	
L7	2	2	2	2	2,5	2,5	2,5	
L8 *	64	64	74	80	94,5	99,5	99,5	
L9 (±1,2) *	78	78	94	100	116	125	125	
L10 (±1) *	37	37	41	45	52,5	53	54,5	
L11	1,5	1,5	1,5	1,5	2	2	2	
MM (f7)	4	4	6	6	8	10	12	
MR	12	12	16	16	18	19	22	
WF (±1,2)	16	16	22	22	24	28	28	
XC (±1) *	64	64	75	82	95	104	105	
Y (±1,2)	20,5	20,5	26,5	27,5	32	36	35	
Stroke tolerance: until stroke 100 +1,5 mm, beyond +2 mm								
Weight	stroke 0	30	35	65	80	160	200	310
g	every 10mm	2	2,5	4	5	7,5	11,5	18
<b>Variations of the versions:</b> <i>without rear eye version</i>								
Weight	stroke 0	25	30	60	75	150	185	290
g	every 10mm	2	2,5	4	5	7,5	11,5	18
<i>Through rod cylinder version</i>								
Weight	stroke 0	35	40	75	95	200	250	370
g	every 10mm	2,5	3	6	7	10,5	15,5	24

Dimensions marked with \* do not increase proportionally to stroke for rear spring version (over 25 mm stroke).

PNEUMATIC ACTUATION 3





## Series 1200, Rolled end caps "MIR-INOX"

### Construction characteristics

End caps	stainless steel AISI 316
Barrel	stainless steel AISI 304
Piston rod	stainless steel
Piston	aluminium
Piston seals	Standard: NBR oil resistant rubber, PUR piston rod seals (FPM seals available upon request)
Mounting	stainless steel AISI 304
Forks	stainless steel AISI 304

### Operational characteristics

Fluid	Filtered air. No lubrication needed, if applied it shall be continuous.
Maximum working pressure	10 bar
Working temperature	-5°C - +70°C with standard seals magnetic or non magnetic piston -5°C - +80°C with FPM seals magnetic piston -5°C - +150°C with FPM seals non magnetic piston

Please follow the suggestions below to ensure a long life for these cylinders:

- use clean and lubricated air
- correct alignment during assembly with regard to the applied load so as to avoid radial components or bending the rod.
- avoid high speeds together with long strokes and heavy loads: this would produce kinetic energy which the cylinder cannot absorb, especially if used as a limit stop (in this case use mechanical stop device)
- evaluate the environmental characteristics of cylinder used (high temperature, hard atmosphere, dust, humidity etc.)

**Please note: air must be dried for applications with lower temperature.**

Use hydraulic oils H class (ISO VG32) for correct continued lubrication.

Our Technical Department will be glad to help.

### Standard strokes

#### Double acting version

Ø16 : 15 - 25 - 50 - 75 - 80 - 100 - 150 - 160 - 200 - 250 - 300 mm

Ø20 - Ø25 : 15 - 25 - 50 - 75 - 80 - 100 - 150 - 160 - 200 - 250 - 300 - 320 - 350 - 400 mm

Ø32 : 15 - 25 - 50 - 75 - 80 - 100 - 150 - 160 - 200 - 250 - 300 - 320 - 350 - 400 - 450 - 500 mm

On request are available strokes up to:

Ø16 : 700 mm

Ø20 - Ø32: 1000 mm

### Basic version

Ordering code	Description
1280.Ø.stroke.X	Inox non-magnetic version, NBR seals
1280.Ø.stroke.XV	Inox non-magnetic, FPM seals
1280.Ø.stroke.AX	Inox non-magnetic version with cushions*, NBR seals
1280.Ø.stroke.AXV	Inox non-magnetic version with cushions*, FPM seals
1280.Ø.stroke.MX	Inox magnetic version, NBR seals
1280.Ø.stroke.MXV	Inox magnetic version, FPM seals
1280.Ø.stroke.AMX	Inox magnetic version with cushions*, NBR seals
1280.Ø.stroke.AMXV	Inox magnetic version with cushions*, FPM seals

\* no adjustable cushioning

Standard version, fully complying with ISO standards.

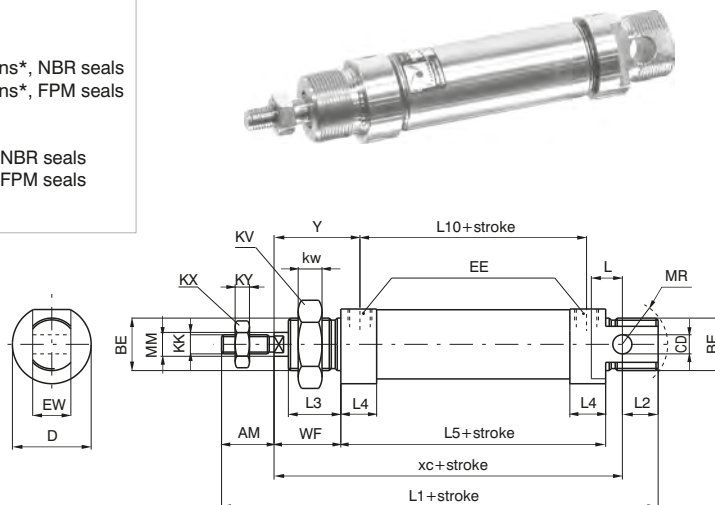

### Through rod cylinder version

Ordering code	Description
1282.Ø.stroke.X	Inox non-magnetic version, NBR seals
1282.Ø.stroke.XV	Inox non-magnetic, FPM seals
1282.Ø.stroke.AX	Inox non-magnetic version with cushions*, NBR seals
1282.Ø.stroke.AXV	Inox non-magnetic version with cushions*, FPM seals
1282.Ø.stroke.MX	Inox magnetic version, NBR seals
1282.Ø.stroke.MXV	Inox magnetic version, FPM seals
1282.Ø.stroke.AMX	Inox magnetic version with cushions*, NBR seals
1282.Ø.stroke.AMXV	Inox magnetic version with cushions*, FPM seals

\* no adjustable cushioning

This version having rods coming out from both end caps, with overall dimensions, except for the rod, equal to 1280 version.

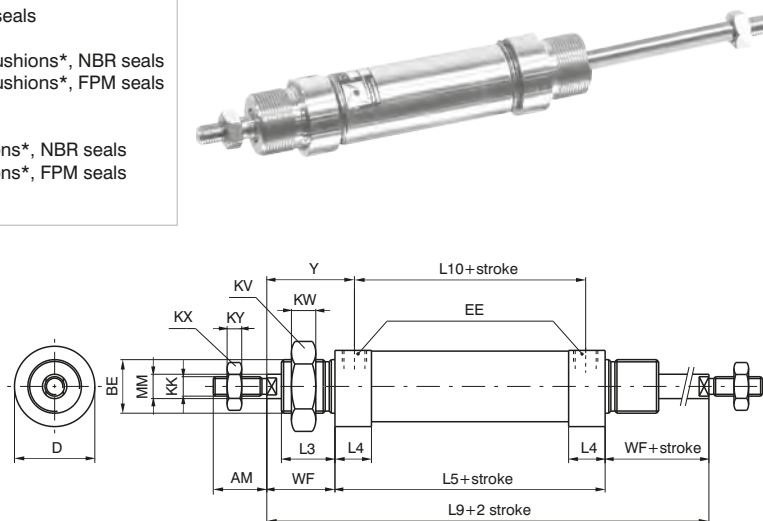

3

PNEUMATIC ACTUATION

### Table of dimensions

Bore	AM	BE	CD	D	EE	EW	KK	KV	KW	KX	KY	L	L1	L2	L3	L4	L5	L9	L10	MM	MR	WF	XC	Y
16	16	M16X1,5	6	21	M5	12	M6X1	22	6	10	4	9	111	13	17	10,5	56	100	45	6	16	22	82	27,5
20	20	M22X1,5	8	27	G1/8"	16	M8X1,25	30	7	13	5	12	130	15	18	10,5	68	116	52,5	8	18	24	95	32
25	22	M22X1,5	8	30	G1/8"	16	M10X1,25	30	7	17	6	13	140	15	22	15,5	68	125	52,5	10	18	28	104	36
32	20	M30X1,5	12	38	G1/8"	26	M10X1,25	42	8	17	6	13	139	14	22	14,5	69	125	54,5	12	22	28	105	35

Bore	Standard weight (g)		Weight through rod version (g)	
	Stroke 0	every 10 mm	Stroke 0	every 10 mm
16	145	5	180	7
20	280	8	330	11
25	370	12	440	16
32	580	18	660	24



## Series 1200, TECNO-MIR

### Construction characteristic

End caps	nylon 66 reinforced with glass fibres
Barrel	nylon 66 reinforced with glass fibres
Piston rod	C43 Chromed (non magnetic piston version) stainless steel (magnetic piston version)
Piston	aluminium
Seal	NBR oil-resistant rubber seal
Piston rod seal	PUR
Mounting	steel painted / stainless steel AISI 304
Forks	zinc plated steel / stainless steel AISI 304

### Operational characteristics

Fluid	Filtered air. No lubrication needed, if applied it shall be continuous.
Maximum working pressure	8 bar
Working temperature	-5°C - +50°C

Please follow the suggestions below to ensure a long life for these cylinders:

- use clean and lubricated air
- correct alignment during assembly with regard to the applied load so as to avoid radial components or bending the rod.
- avoid high speeds together with long strokes and heavy loads: this would produce kinetic energy which the cylinder cannot absorb, especially if used as a limit stop (in this case use mechanical stop device)
- evaluate the environmental characteristics of cylinder used (high temperature, hard atmosphere, dust, humidity etc.)

**Please note: air must be dried for applications with lower temperature.**

Use hydraulic oils H class (ISO VG32) for correct continued lubrication.

Our Technical Department will be glad to help.

### Standard strokes

#### Double acting version

Ø12 : 15 - 25 - 50 - 75 - 80 - 100 - 125 - 150 - 160 - 200 mm

Ø16 : 15 - 25 - 50 - 75 - 80 - 100 - 125 - 150 - 160 - 200 - 250 mm

Ø20 - Ø25 : 15 - 25 - 50 - 75 - 80 - 100 - 125 - 150 - 160 - 200 - 250 - 300 mm

On request are available strokes up to:

Ø12 : 200 mm

Ø16 : 250 mm

Ø20 - Ø25: 300 mm

### Maximum tightening torque for fittings

Bore	Thread	Maximum torque (Nm)
Ø 12	M5	1
Ø 16	M5	1
Ø 20	G 1/8"	4
Ø 25	G 1/8"	4

WEIGHT TABLE SERIES TECNO MIR 1230 - 1231

WEIGHT g	Bore	Ø12	Ø16	Ø20	Ø25
	stroke 0	50 gr.	65 gr.	120 gr.	160 gr.
	every 10mm	3,75 gr.	4 gr.	6,5 gr.	9 gr.

WEIGHT TABLE SERIES TECNO MIR 1232

WEIGHT g	Bore	Ø12	Ø16	Ø20	Ø25
	stroke 0	60 gr.	75 gr.	180 gr.	200 gr.
	every 10mm	7 gr.	8,5 gr.	10 gr.	20 gr.

### Basic version

Ordering code	Description
<b>1230.Ø.stroke</b>	Basic version
<b>1230.Ø.stroke.M</b>	Basic version magnetic piston

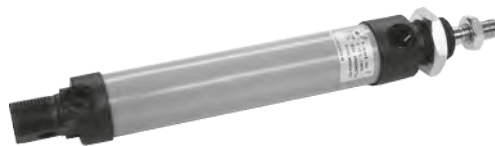

Standard version, fully complying with ISO standards. Can use all available mountings.

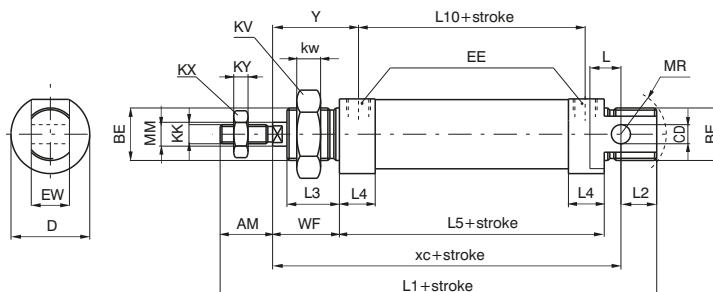

### Without rear eye version

Ordering code	Description
<b>1231.Ø.stroke</b>	Without rear eye version
<b>1231.Ø.stroke.M</b>	Without rear eye version magnetic piston



This version derived from standard version 1230 and not included in ISO standard. Not having a rear eye it is shorter. The inlet connection is lateral on the rear caps (like on the front caps).

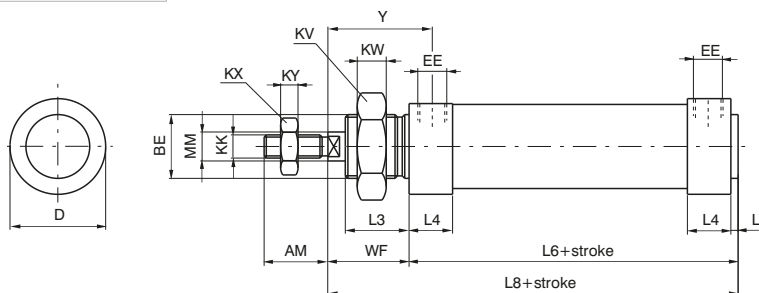

### Through rod cylinder version

Ordering code	Description
<b>1232.Ø.stroke</b>	Through rod cylinder version
<b>1232.Ø.stroke.M</b>	Through rod cylinder version magnetic piston



Through rod model, dimensions as for the 1230 (except the rod).

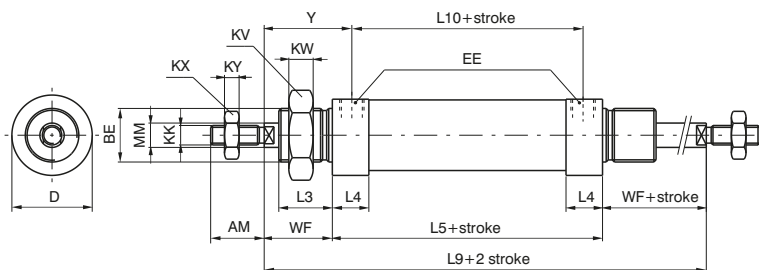

Table of dimensions

Bore	AM (-0,2)	BE	CD (H9)	D (h11)	EE	EW (d13)	KK (6g)	KV	KW	KX	KY	L	L1 (±1)	L2	L3	L4	L5 (±1)	L6	L7	L8	L9 (±1,2)	L10 (±1)	MM (f7)	WF (±1,2)	XC (±1)	Y (±1)
12	16	M16X1,5	6	19	M5	12	M6X1	22	6	10	4	9	105	14	17	13,5	50	52	2	74	94	41	6	22	75	26,5
16	16	M16X1,5	6	23	M5	12	M6X1	22	6	10	4	9	111	13	17	14,5	56	58	2	80	100	45	6	22	82	27,5
20	20	M22X1,5	8	28,5	G1/8"	16	M8X1,25	30	7	13	5	12	130	15	18	20,5	68	70,5	2,5	94,5	116	52	8	24	95	32
25	22	M22X1,5	8	31,5	G1/8"	16	M10X1,25	30	7	17	6	14	140	14	22	20	68	70,5	2,5	98,5	124	52	10	28	104	36



## Series 1200 Steel line

### General

The 12X stainless steel ISO 6432 microbore cylinders series are designed for corrosion resistance application such as marine, pharmaceutical and food ambiances.

The pre lubrication grease used is NSF H1 certified for food application.

Specific care has been taken during the design stages and the result is a clean profile cylinder easy to clean and free from possible residue build-up areas. All parts in contact with the external environment are in Stainless steel 316L and the seals are available in three different compounds for different temperature applications:

PUR -30°C - +80°C, FPM -5°C - +150°C and NBR -5°C - +70°C.

The range starts from 16 bore up to 63 bore, double acting version standard or with through rod, magnetic or not magnetic piston available.

The end caps are crimped onto the barrel for bore sizes 16 to 25 and screwed on the barrel from 32 to 63 bore.

Depending on the type of mounting required it is possible to choose different end caps style.

The piston is aluminium and the sensor bracket, when required is in stainless steel 316 with plastic adaptor or in plastic material. The cylinder can be fixed with the wide range of stainless steel accessories.

### Construction characteristics

End caps, barrel, piston rod	Stainless steel AISI 316
Piston	Aluminium
Seals	NBR (PUR piston rod seals) FPM PUR
Fixing / Accessories	AISI 316 / 304

### Operational characteristics

Fluid	Filtered air. No lubrication needed, if applied it shall be continuous.
Max. pressure	10 bar
Bore	Ø 16 - 20 - 25 - 32 - 40 - 50 - 63
Cushioning length	mm 15 - 18 - 18 - 18 - 22 - 22 - 25

### Operating temperature

Seals material	Operating temperature	Piston		Cushioning		Bores
		Magnetic	Non magnetic	Pneumatic adjustable	Pneumatic fix	
NBR	-5°C - +70°C	●	●	●	●	Ø16-Ø20-Ø25-Ø32-Ø40-Ø50-Ø63
	-5°C - +80°C	●		●	●	Ø16-Ø20-Ø25-Ø32-Ø40-Ø50-Ø63
FPM	-5°C - +150°C		●	●	●	Ø16-Ø20-Ø25-Ø32-Ø40-Ø50-Ø63
	-5°C - +70°C	●	●	●		Ø16-Ø20-Ø25-Ø32
PUR	-30°C - +80°C	●	●		●	Ø16-Ø20-Ø25-Ø32
		●	●	●	●	Ø40-Ø50-Ø63

Please follow the suggestions below to ensure a long life for these cylinders:

- use clean and lubricated air
- correct alignment during assembly with regard to the applied load so as to avoid radial components or bending the rod.
- avoid high speeds together with long strokes and heavy loads: this would produce kinetic energy which the cylinder cannot absorb, especially if used as a limit stop (in this case use mechanical stop device)
- evaluate the environmental characteristics of cylinder used (high temperature, hard atmosphere, dust, humidity etc.)

**Please note: air must be dried for applications with lower temperature.**

Our Technical Department will be glad to help.

### Standard strokes

#### Ø16 :

15 - 25 - 50 - 75 - 80 - 100 - 150 - 160 - 200 - 250 - 300 mm

#### Ø20 - Ø25 :

15 - 25 - 50 - 75 - 80 - 100 - 150 - 160 - 200 - 250 - 300 - 320 - 350 - 400 mm

#### Ø32 - Ø63 :

15 - 25 - 50 - 75 - 80 - 100 - 150 - 160 - 200 - 250 - 300 - 320 - 350 - 400 - 450 - 500 mm



Coding key

12X

FUNCTION	
<b>A</b>	Double acting 
<b>B</b>	Double acting cushioned 
<b>C</b>	Double acting through rod 
<b>D</b>	Double acting cushioned through rod 

BORE
016
020
025
032
040
050
063

STROKE

MAGNETIC PISTON VARIANTS	
<b>M</b>	Magnetic piston max. temperature +80°C
<b>N</b>	Non magnetic piston

SEALS	
<b>N</b>	NBR
<b>V</b>	FPM
<b>P</b>	PUR

	TYPE		
	FRONT END CAP	BASIC VERSION	REAR END CAP
<b>A</b>	CLEAN PROFILE 		WITH INTEGRATED TRUNNION
<b>B</b>	CLEAN PROFILE 		THREADED
<b>C</b>	THREADED 		THREADED
<b>D</b>	THREADED 		SHORT END CAP
<b>E*</b>	FOR PIN 		SHORT END CAP

\* Available only for Ø32 - Ø40 - Ø50 - Ø63

	END CAP	THROUGH ROD CYLINDER VERSION	END CAP
<b>S</b>	THREADED 		THREADED
<b>T</b>	THREADED 		CLEAN PROFILE

3 PNEUMATIC ACTUATION

► Cylinder type "A"

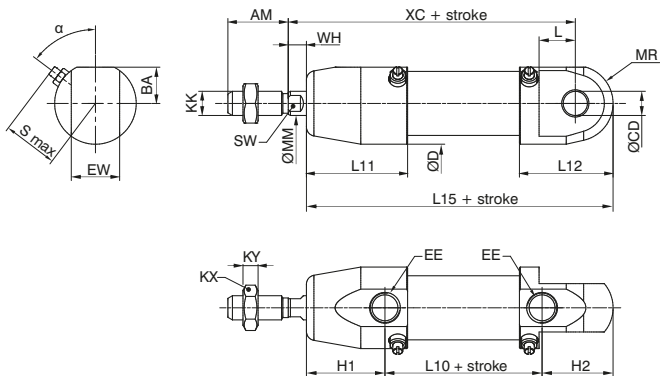

from Ø16 to Ø25

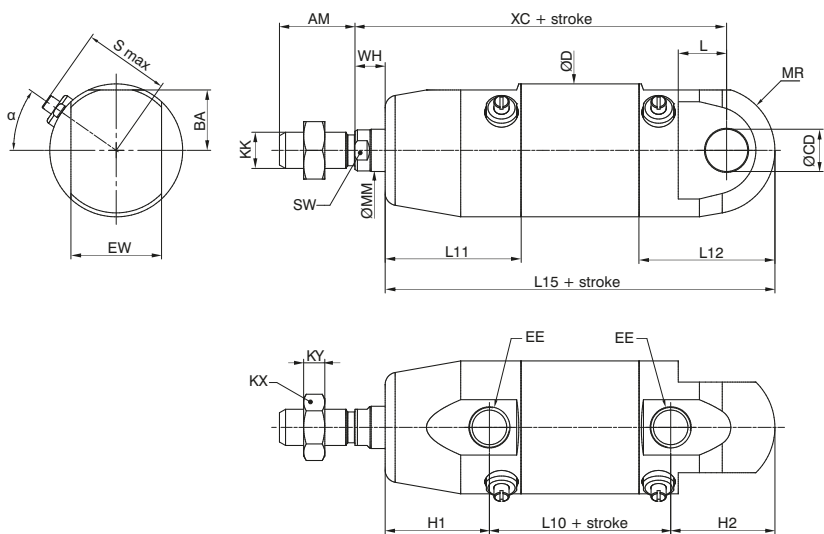

from Ø32 to Ø63

PNEUMATIC ACTUATION

3

► Cylinder type "B"

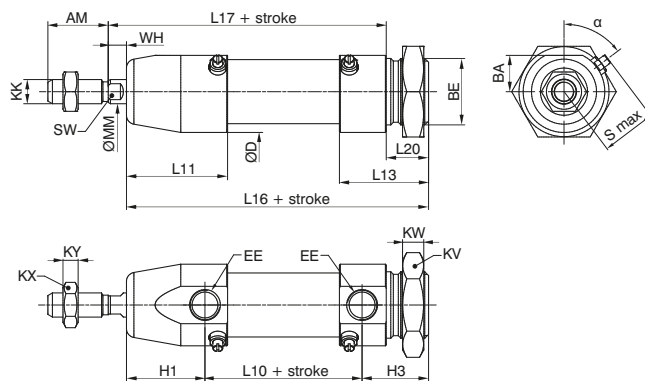

from Ø16 to Ø25

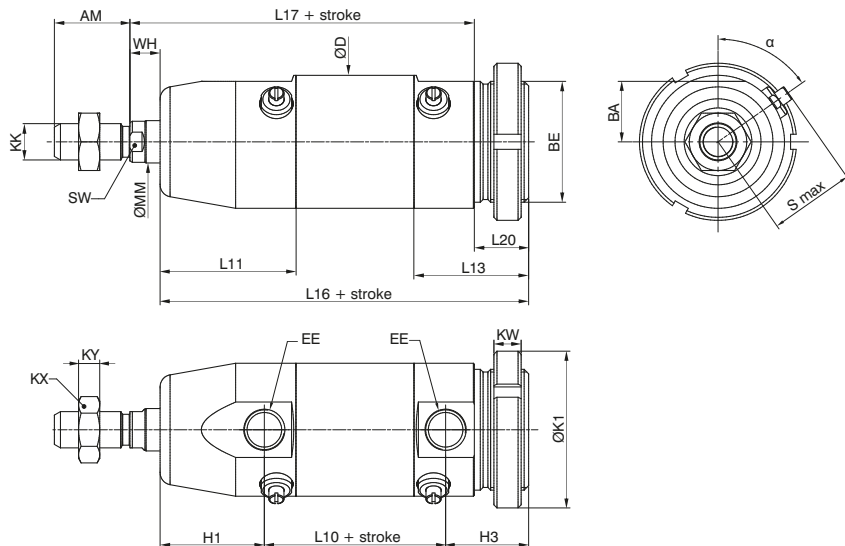

from Ø32 to Ø63

► Cylinder type "C"



from Ø16 to Ø25

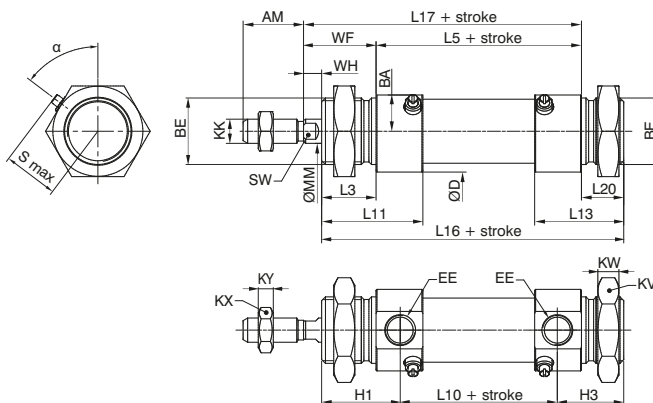

from Ø32 to Ø63

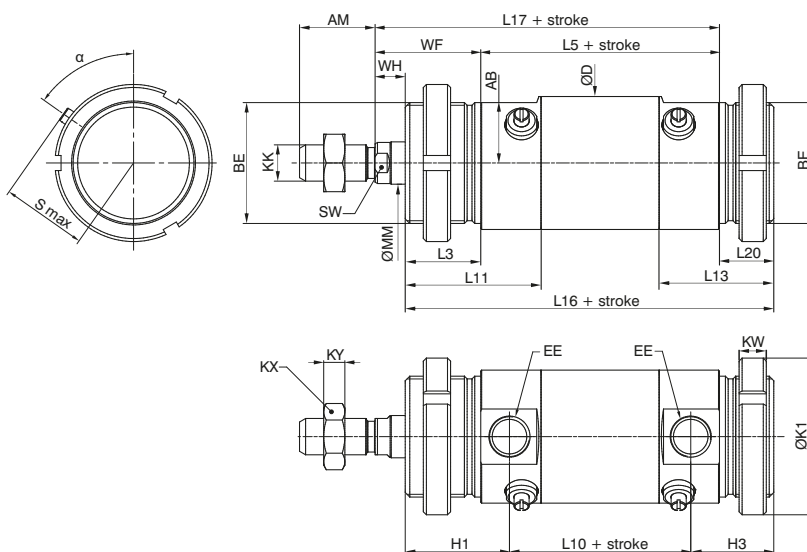

► Cylinder type "D"



from Ø16 to Ø25

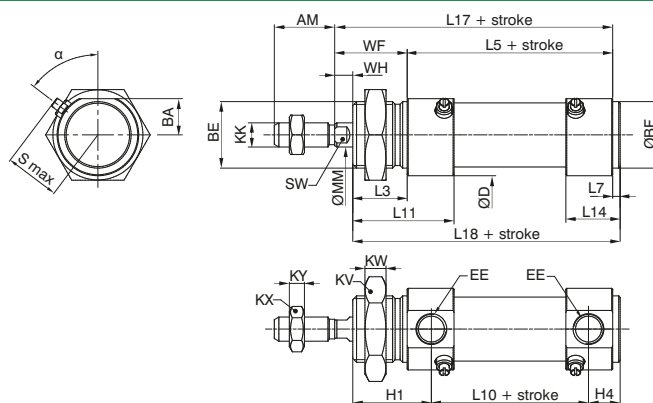

from Ø32 to Ø63

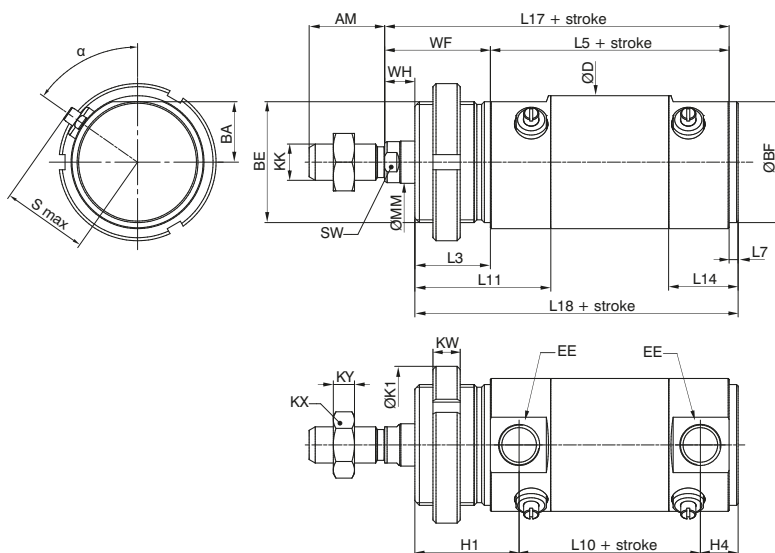

► Cylinder type "E"

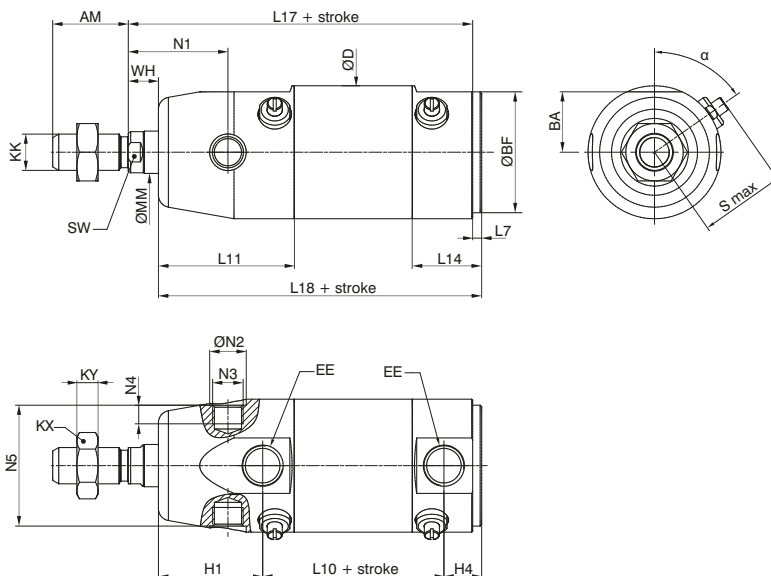

from Ø32 to Ø63

► Cylinder type "S"

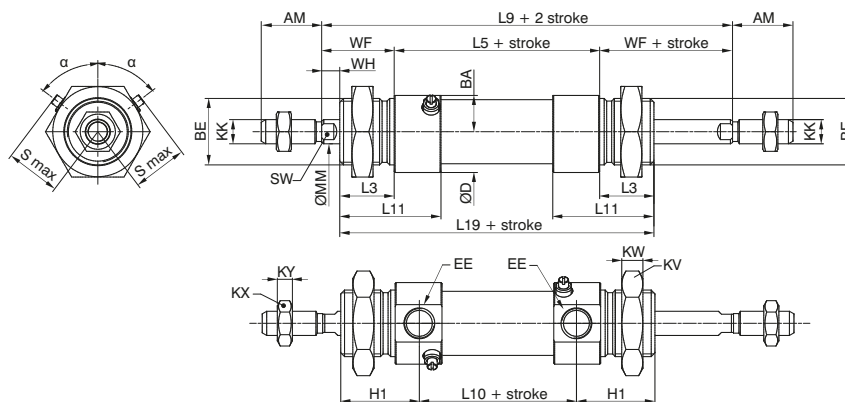

from Ø16 to Ø25

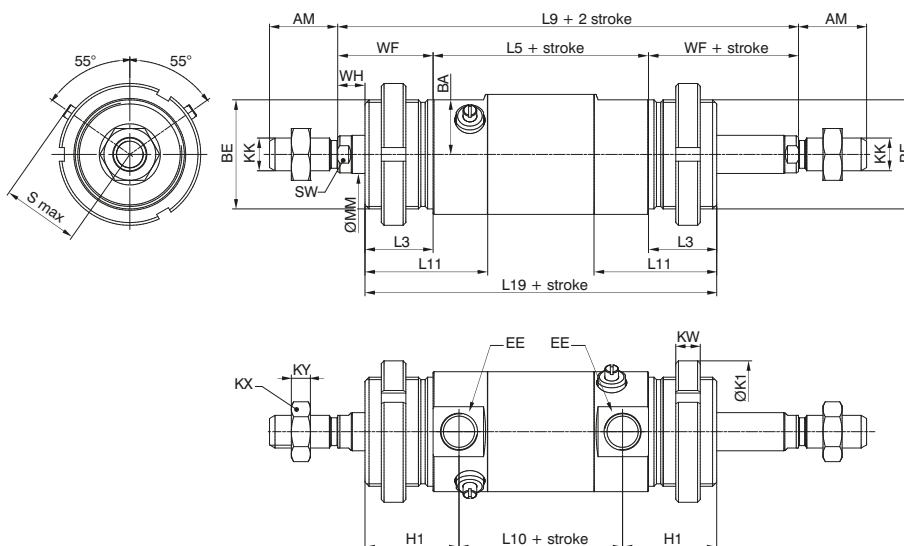

from Ø32 to Ø63

► Cylinder type "T"

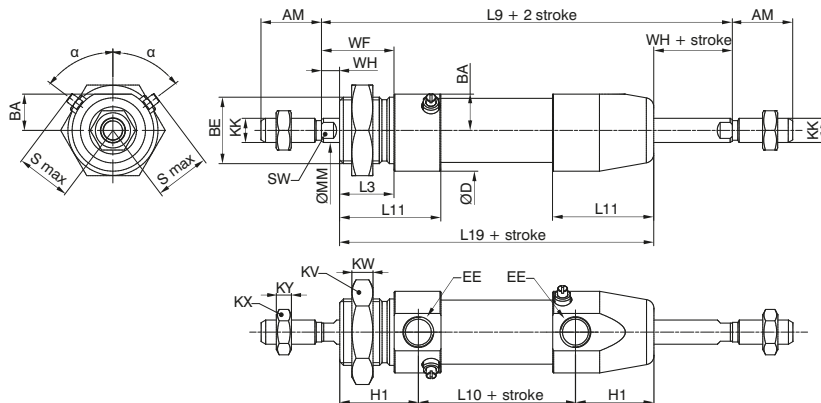

from Ø16 to Ø25

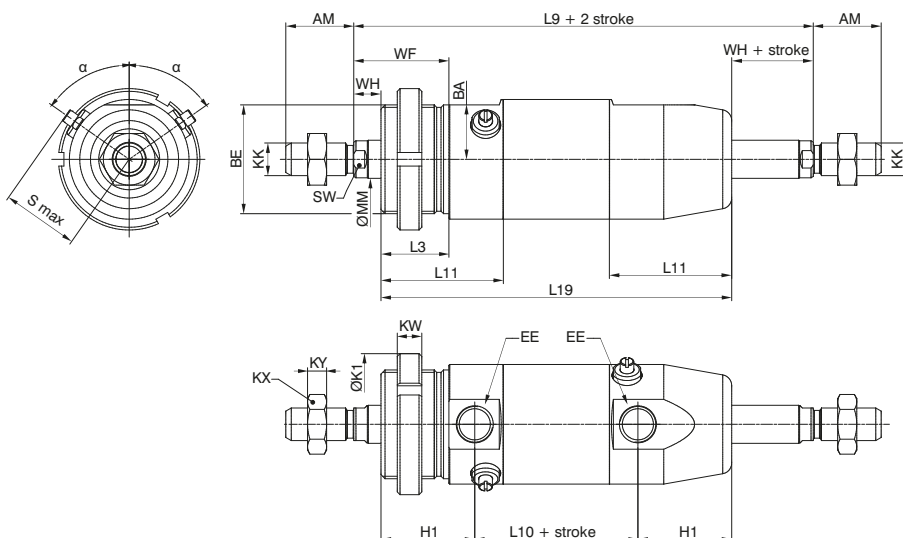

from Ø32 to Ø63

Weight charts

		WEIGHT (g)							
		BASIC VERSION	Ø16	Ø20	Ø25	Ø32	Ø40	Ø50	Ø63
A		Stroke 0	131	264	371	621	1060	1600	3150
		every each 10mm	5	7	11	26	33	42	65
B		Stroke 0	150	310	410	666	1160	1700	3230
		every each 10mm	5	7	11	26	33	42	65
C		Stroke 0	153	323	411	688	1200	1660	3060
		every each 10mm	5	7	11	26	33	42	65
D		Stroke 0	129	267	359	580	1020	1460	2800
		every each 10mm	5	7	11	26	33	42	65
E*		Stroke 0	/	/	/	558	960	1480	2930
		every each 10mm	/	/	/	26	33	42	65

\* Available only for Ø32 - Ø40 - Ø50 - Ø63

		THROUGH ROD CYLINDER VERSION	Ø16	Ø20	Ø25	Ø32	Ø40	Ø50	Ø63
S		Stroke 0	172	350	465	745	1364	1793	3318
		every each 10mm	7	11	18	35	48	58	90
T		Stroke 0	181	336	470	723	1299	1832	3483
		every each 10mm	7	11	18	35	48	58	90

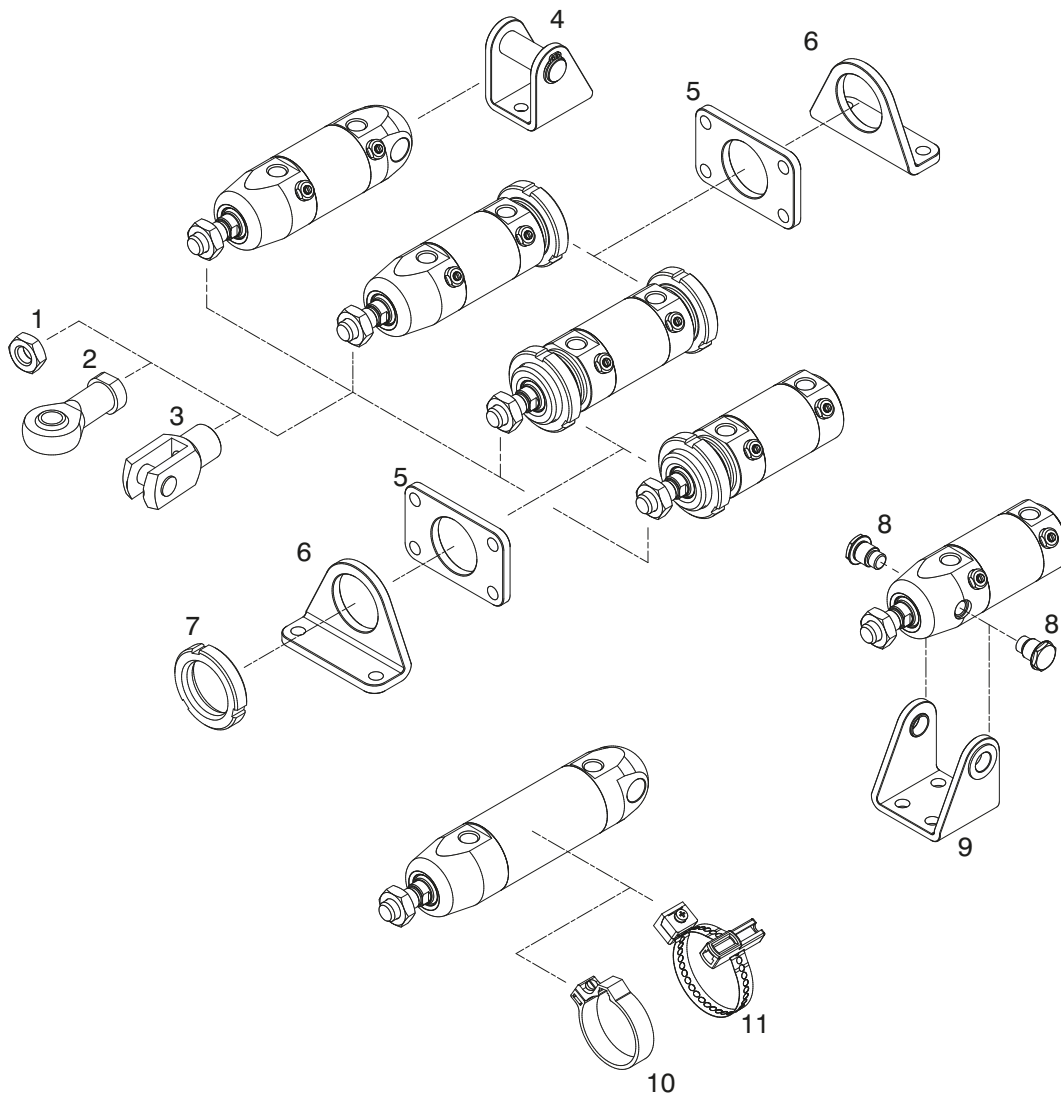

Table of dimensions

Bore	Ø16	Ø20	Ø25	Ø32	Ø40	Ø50	Ø63
α	53°	53°	53°	55°	55°	55°	55°
AM	16	20	22	20	25	25	32
BA	9	12	13,5	16	20	25	31
BE	M16x1,5	M22x1,5	M22x1,5	M30x1,5	M40x1,5	M40x1,5	M45x1,5
ØBF	16	22	22	30	40	40	45
EE	M5	G1/8	G1/8	G1/8	G1/4	G1/4	G3/8
EW	12	16	16	26	30	30	40
ØCD <sup>H9</sup>	6	8	8	12	14	14	16
ØD	21	27	30	36	44	54	68
H1	22,5	26	30	30	34,5	34,5	40
H2	17,5	23,5	27,5	30	34,5	34,5	40
H3	16,5	22	22	23	27,5	27,5	30
H4	7,5	10,5	10,5	10,5	12,5	12,5	16
ØK1	/	/	/	/	52	52	60
KK	M6x1	M8x1,25	M10x1,25	M10x1,25	M12x1,75	M12x1,75	M16x1,5
KX	10	13	17	17	19	19	24
KY	4	5	6	6	7	7	8
KV	22	30	30	42	/	/	/
KW	6	7	7	8	9	9	10
L	9	12	14	13	16	16	22
L3	17	18	22	22	25	25	28
L5	56	68	69	69	79	82	106
L7	2	2,5	2,5	2,5	3	3	4
L9	100	116	125	125	149	152	180
L10	45	52	53	53	60	63	82
L11	28	33,5	37	38,5	45	45	54
L12	23	31	34,5	38,5	45	45	54
L13	22	29,5	29	31,5	38	38	44
L14	12,8	18	17,5	19	23	23	30
L15	85	101,5	110,5	113	129	132	162
L16	84	100	105	106	122	125	152
L17	78	92	97	97	114	117	143
L18	75	88,5	93,5	93,5	107	110	138
L19	90	104	113	113	129	132	162
L20	11	14	14	15	18	18	18
ØMM	6	8	10	12	14	16	20
MR	8	12,5	12,5	17	21	26	34,5
N1	/	/	/	27	33	40	45
ØN2 <sup>+0,-0,05</sup>	/	/	/	10,1	12,1	14,1	16,1
N3	/	/	/	M8x0,75	M10x1	M12x1	M14x1
N4	/	/	/	5,5	6	8,7	11,7
N5 <sup>+0,1,-0</sup>	/	/	/	32	40	50	64
Smax	15,5	18,5	19,5	25	28,5	33,5	40
SW	5	6	8	10	12	12	17
WF	22	24	28	28	35	35	37
WH	5	6	6	6	10	10	9
XC	82	95	104	105	123	126	154

3 PNEUMATIC ACTUATION

Accessories and fixing devices



Position	Description	Ordering code	Materials
1	Rod lock nut	12X.Ø.11	Stainless steel AISI 316
2	Ball joint	12X.Ø.10	Stainless steel
3	Fork	12X.Ø.04	Stainless steel
4	Rear clevis	12X.Ø.03	Stainless steel
5	Flange	12X.Ø.02	Stainless steel AISI 316
6	Foot	12X.Ø.01	Stainless steel AISI 316
7	Nut or lock nut for the endcaps	12X.Ø.05	Stainless steel AISI 316
8	Pin for front clevis (Ø32 - Ø63)	12X.Ø.09	Stainless steel AISI 316
9	Front clevis (Ø32 - Ø63)	12X.Ø.08	Stainless steel AISI 316
10	Sensor clamp (Ø16 - Ø50)	12X.Ø.FS	Technopolymer
11	Sensor clamp (Ø16 - Ø63)	12X.Ø.FSX	Stainless steel Technopolymer

► Sensor clamps cod. 1580.\_, MRS.\_, MHS.\_

Ordering code

**12X.Ø.FS**

The kit comprises:  
n° 1 clamp (Technopolymer)  
n° 1 screw (AISI 304)  
n° 1 nut (AISI 304)

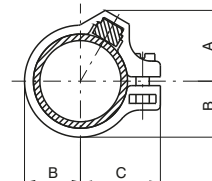
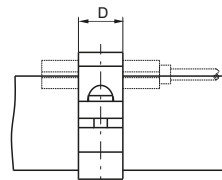

Table of dimensions

Bore	Ø16	Ø20	Ø25	Ø32	Ø40	Ø50
A	14,5	16	17,5	20,5	22	29
B	10,5	12,5	15,3	20	24	29
C	16	18	20,5	26	30	35
D	10	10	10	10	10	10
Weight (g)	3	5	7	8	10	11

Ordering code

**12X.Ø.FSX**

The kit comprises:  
n° 1 clamp (AISI 304)  
n° 1 switch bracket + support (Technopolymer)  
n° 1 screw (AISI 304)  
n° 1 nut (AISI 304)

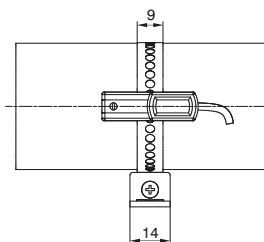
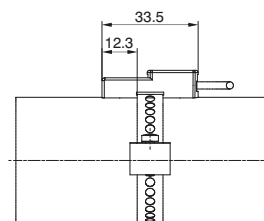
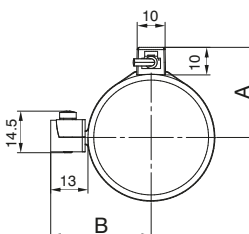

Table of dimensions

Bore	Ø16	Ø20	Ø25	Ø32	Ø40	Ø50	Ø63
A	19	21	23	28	32	37	44
B	22	24	26	31	35	40	47



### Foot

Ordering code
<b>12X.Ø.01</b>

The kit comprises:  
n° 1 foot (AISI 316)

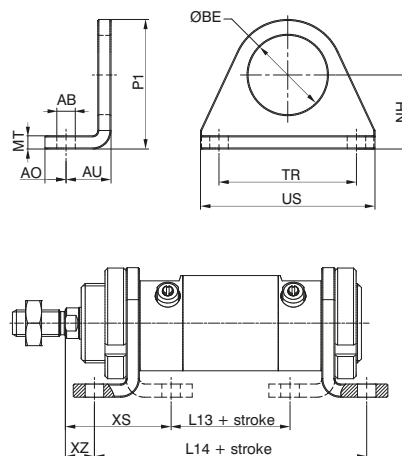

Used to mount the cylinder on the mounting plane with the rod parallel to said plane. Use one for short strokes and two for long strokes. It is made stamped stainless steel AISI 316.

Bore	16	20	25	32	40	50	63
AB (H13)	5,5	6,5	6,5	6,5	9	9	9
AO	6	8	8	8	10	10	10
AU	14	17	17	17	20	20	20
ØBE	16	22	22	30	40	40	45
L13 (±1)	36	44	44	45	49	52	78
L14 (±1)	84	102	102	103	119	122	146
MT	4	5	5	5	5	5	6
NH (±0.3)	20	25	25	28	40	40	50
P1	33	45	45	50	66,5	66,5	80
TR (Js14)	32	40	40	52	70	70	70
US	42	54	54	66	90	90	90
XS (±1.4)	32	36	40	40	50	50	51
XZ (±1.4)	8	7	11	11	15	15	17
Weight g.	45	90	90	110	210	210	262

### Flange

Ordering code
<b>12X.Ø.02</b>

The kit comprises:  
n° 1 flange (AISI 316)



(For Ø16 - Ø20 - Ø25)



(For Ø32 - Ø40 - Ø50 - Ø63)

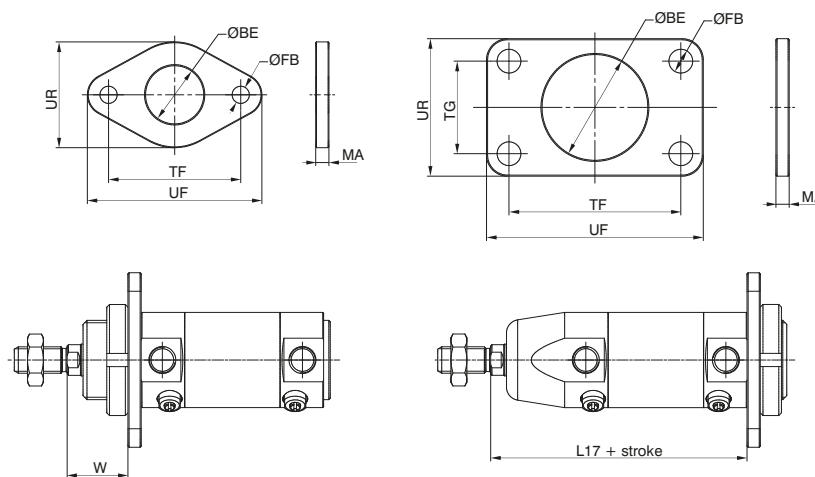

Use to mount the microcylinder at a right angle to the mounting plane. Made of stainless steel AISI 316.

Bore	16	20	25	32	40	50	63
ØBE	16	22	22	30	40	40	45
ØFB (H13)	5,5	6,5	6,5	6,5	9	9	9
UF	53	66	66	68	82	82	96
UR	30	40	40	50	52	52	70
MA	4	5	5	5	5	5	6
TF (JS14)	40	50	50	52	65	65	76
TG	/	/	/	/	35	35	50
W (±1.4)	18	19	23	23	30	30	31
L17	78	92	97	97	114	117	143
Weight g.	40	85	85	100	105	105	225

**Rear clevis**

Ordering code

**12X.Ø.03**

The kit comprises:  
 n° 1 clevis (AISI 316)  
 n° 1 pin (AISI 316)  
 n° 2 circlips (AISI 420)

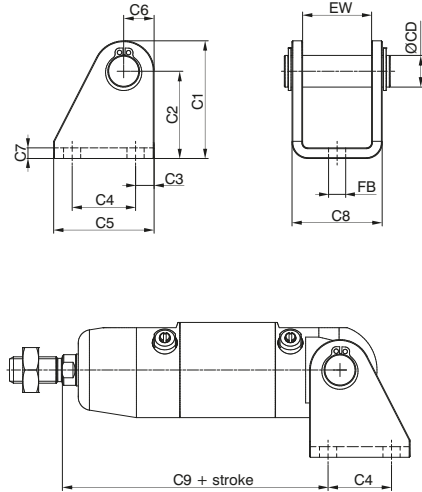

Used to mount by using the rear end cover to mount either parallel or at a right angle to the mounting plane. Allows the cylinder to oscillate and self-align with the linked element to the rod. Necessary to use when the rod may be subject to lateral forces during travel.

Made of stamped stainless steel.

Bore	16	20	25	32	40	50	63
ØCD	6	8	8	12	14	14	16
C1	33,5	39,5	39,5	44,5	53,5	53,5	64
C2 (±0.3)	27	30	30	33	40	40	50
C3	5	6	6	7	10	10	8
C4	15	20	20	24	28	28	34
C5	25	32	32	38	45	45	50
C6	6,5	9,5	9,5	11,5	13,5	13,5	14
C7	3	4	4	4	4	4	6
C8	18	24	24	34	38	38	52
C9 (±0.4)	80,5	91,5	100,5	100,5	119,5	122,5	148
EW	12,1	16,1	16,1	26,1	30,5	30,5	40,5
FB (H13)	5,5	6,5	6,5	6,5	8,5	8,5	9
Weight (g)	35	75	75	135	138	138	284

**Rod lock nut / Nut or lock nut for the end cap**

Ordering code

**Rod lock nut**  
**12X.Ø.11**

The kit comprises:  
 n° 1 rod lock nut (AISI 316)

**Nut / Lock nut**  
**for the end cap**  
**12X.Ø.05**

The kit comprises:  
 n° 1 nut/lock nut  
 for the end cap (AISI 316)

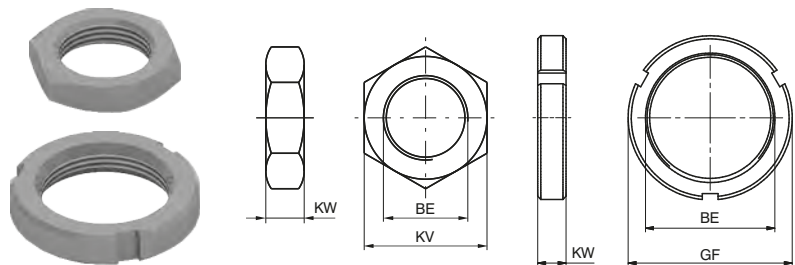
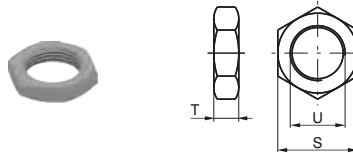

**Rod lock nut:**

Mounted on the rod thread.  
 Made of stainless steel AISI 316.

**Nut / Lock nut for the end cap:**

Used to fasten flanges or feet to the endcaps of the microcylinder. The nuts are mounted on diameters that go from Ø16 to Ø25 mm, the lock nuts from Ø32 to Ø63 mm. Both are supplied with the microbore cylinders.

Bore	S	T	U	Dado stelo Weight (g)	BE	KV	GF	KW	Nut / Lock nut for the end caps weight (g)
16	10	4	M6X1	3	M16X1,5	22	-	6	16
20	13	5	M8X1,25	4	M22X1,5	30	-	7	25
25	17	6	M10X1,25	9	M22X1,5	30	-	7	25
32	17	6	M10X1,25	9	M30X1,5	-	42	8	42
40	19	7	M12X1,75	12	M40X1,5	-	52	9	62
50	19	7	M12X1,75	12	M40X1,5	-	52	9	62
63	24	8	M16X1,5	21	M45X1,5	-	60	10	100

► **Front clevis**

Ordering code
<b>12X.Ø.08</b>

The kit comprises:  
n° 1 clevis (AISI 316)  
n° 2 bushings (Technopolymer)



Used to mount by using the front end cap to mount parallel to the mounting plane. Allows the cylinder to oscillate and self-align with the linked element to the rod. Necessary to use when the rod may be subject to lateral forces during travel. Made of stamped stainless steel AISI 316.

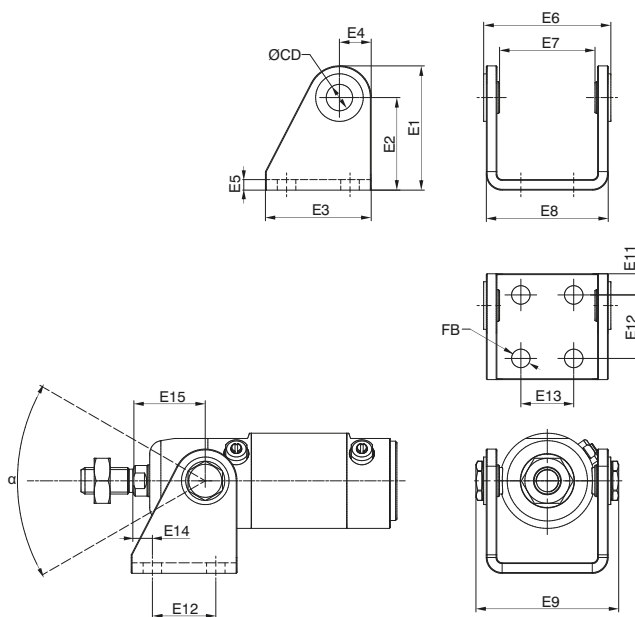

Bore	E1	E2 (±0,2)	E3	E4	E5	E6	E7	E8	E9	E11	E12	E13	E14	E15	FB (H13)	ØCD	α	Weight (g)
32	47	35	40	12	4	48	36	46	54	8	24	20	7	27	7	10	50°	121
40	53	40	50	13	4	60	49	58	68	10	30	28	6	33	9	12	50°	175
50	59	45	54	14	6	74	54	72	84	10	34	36	10	40	9	14	50°	330
63	65	50	65	16	6	88	72	86	98	15	35	42	11	45	9	16	40°	458

► **Pin for front clevis**

Ordering code
<b>12X.Ø.09</b>

The kit comprises:  
n° 1 pin (AISI 316)

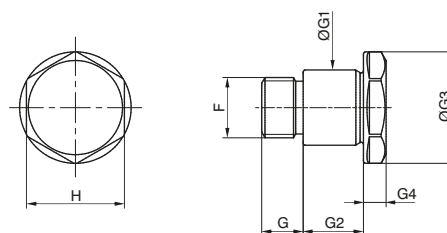

Bore	32	40	50	63
G	5,5	6	8,5	11
G1 (h7)	10	12	14	16
G2	8	10	12	12
G3	15	17	19	24
G4	3	4	5	5
F	M8X0,75	M10X1	M12X1	M14X1
H	13	15	17	21

### Ball joint

Ordering code

**12X.Ø.10**

The kit comprises:  
n° 1 ball joint (AISI 304 and 420)

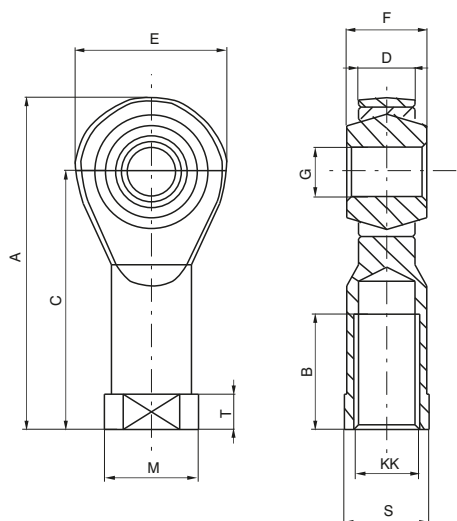

Mounted on the rod thread, assures a regular operation even in the presence of significant forces to the linked element.  
Made of stainless steel AISI 304 and 420.

Bore	16	20	25	32	40	50	63
A	40	48	57	57	66	66	85
B	12	16	20	20	22	22	28
C	30	36	43	43	50	50	64
D	6,75	9	10,5	10,5	12	12	15
E	20	24	28	28	32	32	42
F	9	12	14	14	16	16	21
G (H 7)	6	8	10	10	12	12	16
KK	M6	M8	M10X1,25	M10X1,25	M12X1,75	M12X1,75	M16X1,5
M	13	16	19	19	22	22	27
S	11	14	17	17	19	19	22
T	5	5	6,5	6,5	6,5	6,5	8
Weight (g)	25	25	75	75	112	112	222

### Cylinder rod fork

Ordering code

**12X.Ø.04**

The kit comprises:  
n° 1 fork (AISI 303)  
n° 1 pin (AISI 303)  
n° 2 circlips (AISI 420)

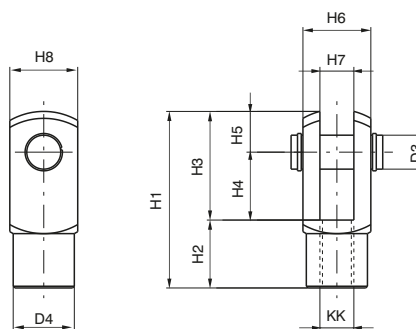

Mounted on the rod thread, assures a regular operation even in the presence of significant forces to the linked element. Made of stainless steel.

Bore	D3	D4	H1	H2	H3	H4	H5	H6	H7 (B12)	H8	KK	Weight (g)
16	6	10	31	12	19	12	7	12	6	12	M6X1	20
20	8	14	42	16	26	16	10	16	8	16	M8X1.25	45
25	10	18	52	20	32	20	12	20	10	20	M10X1.25	90
32	10	18	52	20	32	20	12	20	10	20	M10X1.25	90
40	12	20	62	18	38	24	14	24	12	24	M12X1.75	121
50	12	20	62	18	38	24	14	24	12	24	M12X1.75	121
63	16	26	83	32	51	32	19	32	16	32	M16X1.5	340

► **Sensor clamps for microbore cylinders with threaded end covers and Technopolymer**

<b>Sensor clamps - codes 1500._, RS._, HS._</b>	<b>Sensor clamps - codes 1580._, MRS._, MHS._</b>
Ordering code	Ordering code
<b>1260.Ø.F</b>	<b>1260.Ø.FS</b>

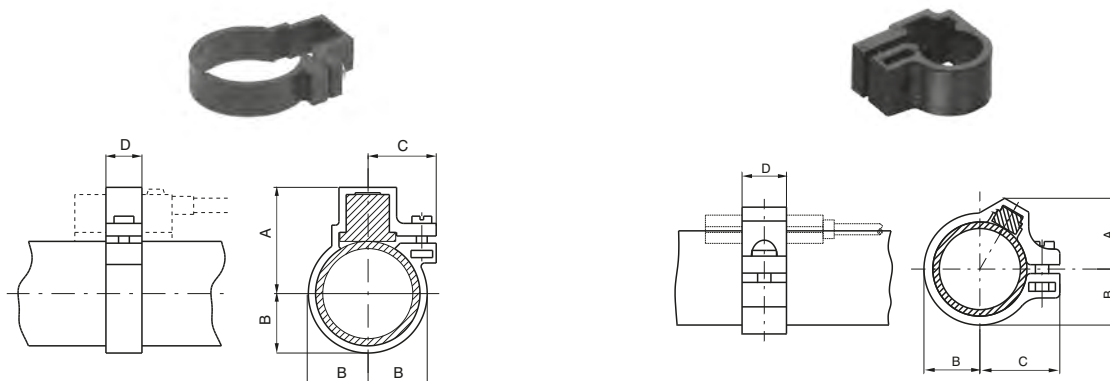

**Table of dimensions**

Bore	Ø10	Ø12	Ø16	Ø20	Ø25	Ø32	Ø40	Ø50
<b>A</b>	23	23	25	27	29,5	33	37	42
<b>B</b>	10	10	12	14	16,5	20	24	29
<b>C</b>	15	15	16,5	17,5	19	20	22	24
<b>D</b>	10	10	10	10	10	10	10	10
Weight (gr)	2	2	3	5	7	10	14	16

**Table of dimensions**

Bore	Ø10	Ø12	Ø16	Ø20	Ø25	Ø32	Ø40	Ø50
<b>A</b>	13	14	15,4	17,2	19,3	20,5	22	29
<b>B</b>	9	10	12	14	16,5	20	24	29
<b>C</b>	16	16	18	19,5	22	26	30	35
<b>D</b>	10	10	10	10	10	10	10	10
Weight (gr)	2	2	3	5	7	8	10	11

► **Sensor clamps for microbore cylinders with rolled end covers "MIR" and "MIR-INOX"**

<b>Sensor clamps - codes 1500._, RS._, HS._</b>	<b>Sensor clamps - codes 1580._, MRS._, MHS._</b>
Ordering code	Ordering code
<b>1280.Ø.F - cylinders MIR</b> <b>1280.Ø.FX - cylinders MIR-INOX</b>	<b>1280.Ø.FS - cylinders MIR</b> <b>1280.Ø.FSX - cylinders MIR-INOX</b>

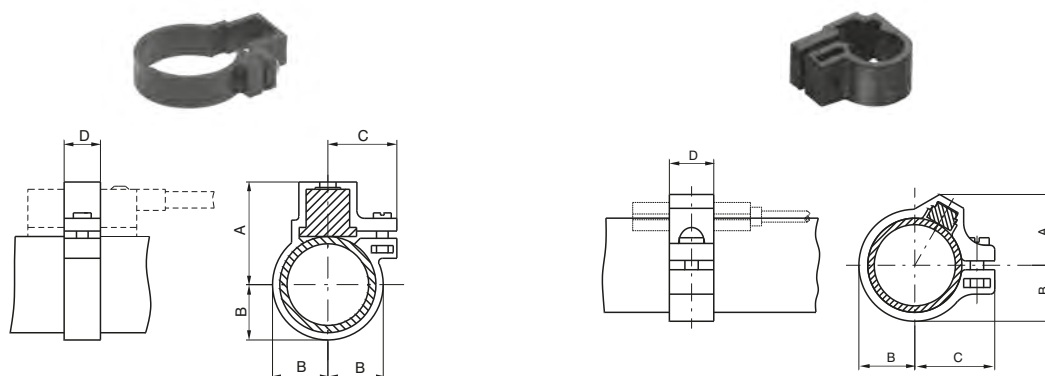

**Table of dimensions**

Bore	Ø16	Ø20	Ø25	Ø32
<b>A</b>	24	25,5	28,5	31,8
<b>B</b>	10,5	12,5	15,5	18,8
<b>C</b>	16,5	17,5	19	20
<b>D</b>	10	10	10	10
Weight (gr)	3	5	7	10

**Table of dimensions**

Bore	Ø8	Ø10	Ø12	Ø16	Ø20	Ø25	Ø32
<b>A</b>	11	12	13	14,5	16	17,5	19,5
<b>B</b>	6,5	7,5	8,5	10,5	12,5	15,3	18,8
<b>C</b>	12,5	13,5	15	16	18	20,5	24
<b>D</b>	10	10	10	10	10	10	10
Weight (gr)	2	2	2	3	5	7	10

**Sensor for microbore cylinders**

For technical characteristics and ordering codes see the magnetic sensors sections

Foot

Ordering code

**1200.Ø.01**  
( 1 piece )

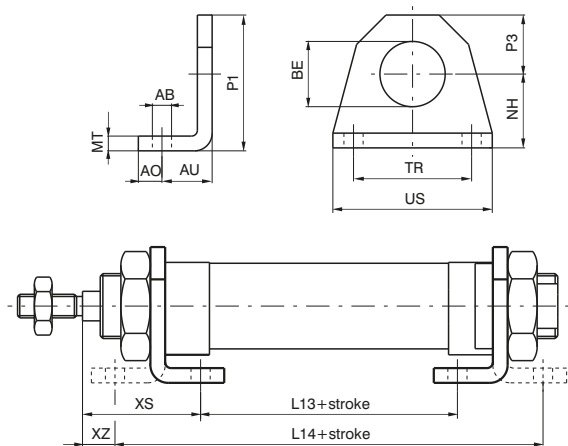
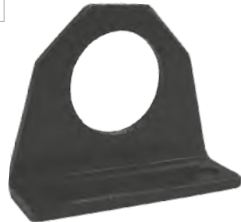

Used to mount the cylinder on the mounting plane with the rod parallel to said plane. Use one for short strokes and two for long strokes. It is made of stamped steel, made corrosion resistant by cathophoresis treatment. Attached to the end caps by means of nuts (or lock nuts) 05.

**Attention: the dimensions of microbore cylinders with threaded end covers (\*) increase of 10 mm. for microbore cylinders equipped with magnetic piston and spring return, and of 9 mm. for microbore cylinders with 10 mm. BORE magnetic piston.**

Bore	8	10	12	16	20	25	32	40	50
AB (H13)	4,5	4,5	5,5	5,5	6,5	6,5	6,5	8,5	8,5
AO	5	5	6	6	8	8	8	10	10
AU	11	11	14	14	17	17	17	20	20
BE	12	12	16	16	22	22	30	40	40
L13 (±1) *	30	30	30	36	44	45	45	49	52
L14 (±1) *	68	68	78	84	102	103	103	119	122
MT	3	3	4	4	5	5	5	5	5
NH (±0,3)	16	16	20	20	25	25	28	40	40
P1	26	26	33	33	45	45	50	70	70
P3	10	10	13	13	20	20	22	30	30
TR (JS14)	25	25	32	32	40	40	52	70	70
US	35	35	42	42	54	54	66	90	90
XS (±1,4)	24	24	32	32	36	40	40	50	50
XZ (±1,4)	5	5	8	8	7	11	11	15	15
Weight g.	22	22	45	45	90	90	110	210	210

Flange

Ordering code

**1200.Ø.02**  
( 1 piece )

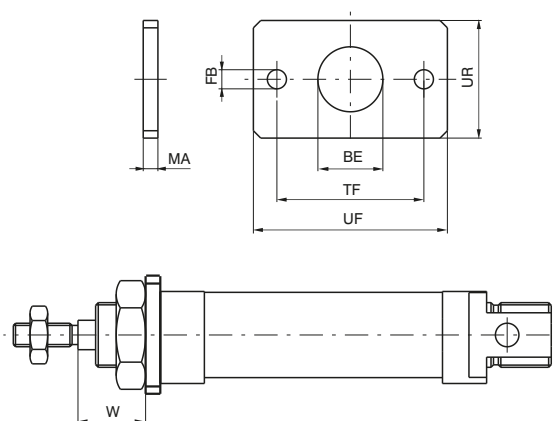
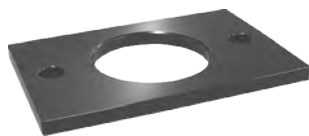

Used to mount the microcylinder at a right angle to the mounting plane. Attached to the front (or rear) end cap by a nut (or lock nut) 05. Made of extruded steel, made corrosion resistant by cathophoresis.

Bore	8	10	12	16	20	25	32	40	50
BE	12	12	16	16	22	22	30	40	40
FB (H13)	4,5	4,5	5,5	5,5	6,5	6,5	6,5	8,5	8,5
UF	40	40	53	53	66	66	68	90	90
UR	25	25	30	30	40	40	50	60	60
MA	3	3	4	4	5	5	5	5	5
TF (JS14)	30	30	40	40	50	50	52	70	70
W (±1,4)	13	13	18	18	19	23	23	30	30
Weight g.	20	20	40	40	85	85	100	150	150

► Rear eye

Ordering code
<b>1200.Ø.03</b> (1 piece)

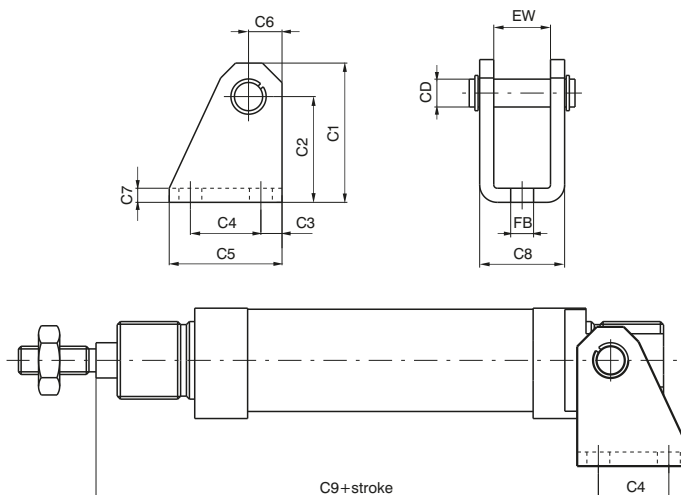

Use with the rear end cover to mount the cylinder either parallel or at a right-angle to the mounting plane. This allows the cylinder to oscillate and self-align with the linked element to the rod. This is necessary when the rod may be subject to lateral during travel.

**Attention: the dimensions of microbore cylinders with threaded end covers (\*) increase by 10mm for equipped with magnetic piston and spring return, and by 9mm for microbore cylinders with 10mm BORE magnetic piston.**

Bore	8	10	12	16	20	25	32	40	50
CD	4	4	6	6	8	8	12	14	14
C1	28,5	28,5	33,5	33,5	39,5	39,5	44,5	53,5	53,5
C2 (±0,3)	24	24	27	27	30	30	33	40	40
C3	3,5	3,5	5	5	6	6	7	10	10
C4	12,5	12,5	15	15	20	20	24	28	28
C5	20	20	25	25	32	32	38	45	45
C6	4,5	4,5	6,5	6,5	9,5	9,5	11,5	13,5	13,5
C7	2,5	2,5	3	3	4	4	4	4	4
C8	13	13	18	18	24	24	34	38	38
C9 (±0,4) *	63	63	73,5	80,5	91,5	100,5	100,5	119,5	122,5
EW	8,1	8,1	12,1	12,1	16,1	16,1	26,1	30,1	30,1
FB (H13)	4,5	4,5	5,5	5,5	6,5	6,5	6,5	8,5	8,5
Weight g.	20	20	35	35	75	75	135	180	180

► Cylinder rod forks

Ordering code
<b>1200.Ø.04 *</b> (with pin)
<b>1200.Ø.04/1</b> (with pin)
*Available from bore Ø12

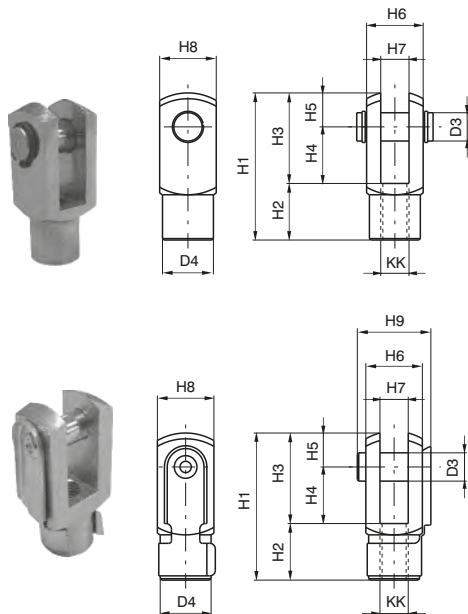

**Forks:**  
Similar to hinge 03, mounted on the rod thread, assures a regular operation even in the presence of significant forces to the linked element. Made of zinc plated steel.

**Nut:**  
Used to fasten flanges or feet to the endcaps of the microcylinder. The nuts are mounted on BORE that go from 8 to 25, the lock nuts on 32, 40 and 50. Both are supplied (one piece) with the microbore cylinders.

► Nut or lock nut for the endcaps

Ordering code
<b>1200.Ø.05</b>

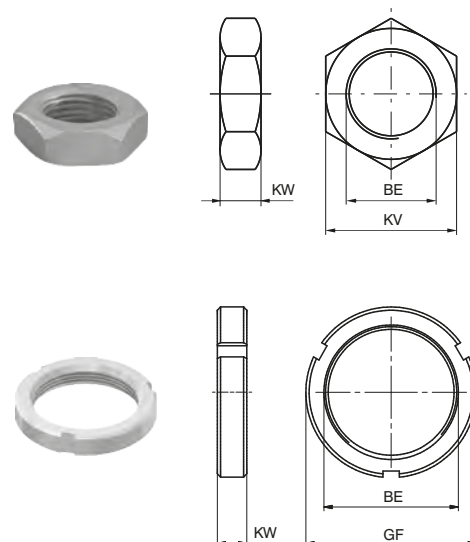

Bore	D3	D4	H1	H2	H3	H4	H5	H6	H7 (B12)	H8	H9	KK	BE	KV	GF	KW	Forks weight g.	Nuts weight g.
8	4	8	21	8	13	8	5	8	4	10	11	M4x0,7	M12x1,25	17	-	5,5	12	7
10	4	8	21	8	13	8	5	8	4	10	11	M4x0,7	M12x1,25	17	-	5,5	12	7
12	6	10	31	12	19	12	7	12	6	12	18	M6x1	M16x1,5	22	-	6	20	16
16	6	10	31	12	19	12	7	12	6	12	18	M6x1	M16x1,5	22	-	6	20	16
20	8	14	42	16	26	16	10	16	8	16	23	M8x1,25	M22x1,5	30	-	7	45	25
25	10	18	52	20	32	20	12	20	10	20	27	M10x1,25	M22x1,5	30	-	7	90	25
32	10	18	52	20	32	20	12	20	10	20	27	M10x1,25	M30x1,5	-	42	8	90	42
40	12	20	62	24	38	24	14	24	12	24	32	M12x1,75	M40x1,5	-	52	9	145	60
50	12	20	62	24	38	24	14	24	12	24	32	M12x1,75	M40x1,5	-	52	9	145	60

### Foot

Ordering code

**1200.Ø.01X**  
( 1 piece )

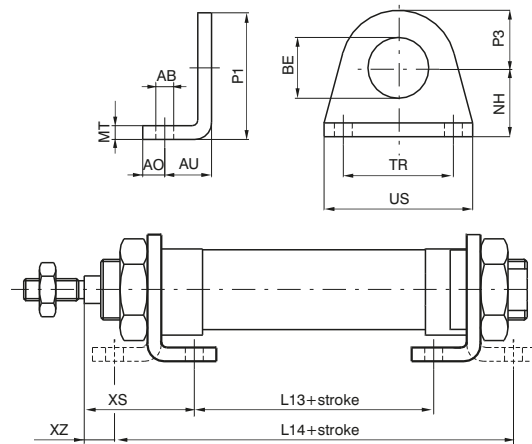

Used to mount the cylinder on the mounting plane with the rod parallel to said plane. Use one for short strokes and two for long strokes. It is made stamped stainless steel AISI 304. Attached to the end caps by means of nuts (or lock nuts) 05X.

Bore	16	20	25	32
AB (H13)	5,5	6,5	6,5	6,5
AO	6	8	8	8
AU	14	17	17	17
BE	16	22	22	30
L13 (±1)	36	44	44	45
L14 (±1)	84	102	102	103
MT	4	5	5	5
NH (±0,3)	20	25	25	28
P1	33	45	45	50
P3	13	20	20	22
TR (Js14)	32	40	40	52
US	42	54	54	66
XS (±1,4)	32	36	40	40
XZ (±1,4)	8	7	11	11
Weight g	45	90	90	110

### Flange

Ordering code

**1200.Ø.02X**

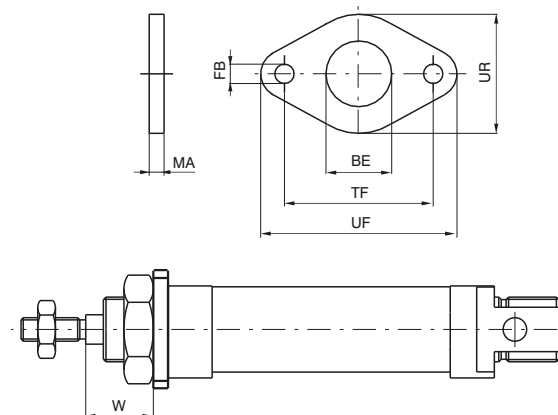

Use to mount the microbore cylinder at a right angle to the mounting plane. Attached to the front (or rear) endcap by a nut (or lock nut) 05X. Made of stainless steel AISI 304.

Bore	16	20	25	32
BE	16	22	22	30
FB (H13)	5,5	6,5	6,5	6,5
UF	53	66	66	68
UR	30	40	40	50
MA	4	5	5	5
TF (JS14)	40	50	50	52
W (±1,4)	18	19	23	23
Weight g	40	85	85	100



**Rear eye**

Ordering code
<b>1200.Ø.03X</b> (1 piece)

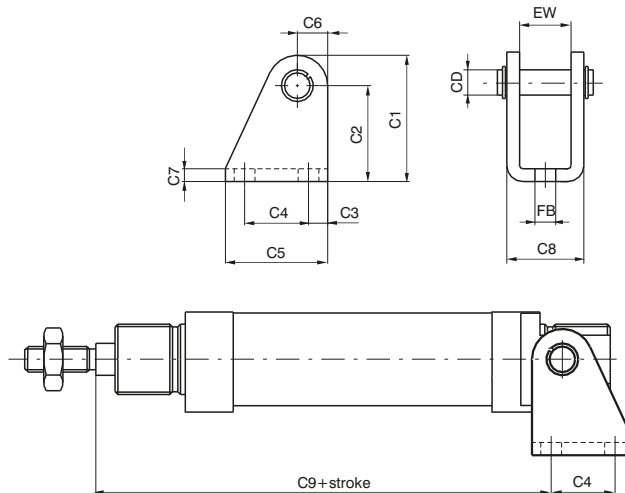

Used to mount by using the rear end cover to mount either parallel or at a right angle to the mounting plane. Allows the cylinder to oscillate and self-align with the linked element to the rod. Necessary to use when the rod may be subject to lateral forces during travel.

Made of stamped stainless steel AISI 304.

Bore	16	20	25	32
CD	6	8	8	12
C1	33,5	39,5	39,5	44,5
C2 (±0,3)	27	30	30	33
C3	5	6	6	7
C4	15	20	20	24
C5	25	32	32	38
C6	6,5	9,5	9,5	11,5
C7	3	4	4	4
C8	18	24	24	34
C9 (±0,4)	80,5	91,5	100,5	100,5
EW	12,1	16,1	16,1	26,1
FB (H13)	5,5	6,5	6,5	6,5
Weight g.	35	75	75	135



PNEUMATIC ACTUATION

**Cylinder rod fork / Nut or lock nut for the endcaps**

Ordering code
<b>1200.Ø.04X</b> (with pin)
<b>1200.Ø.05X</b> (1 piece)

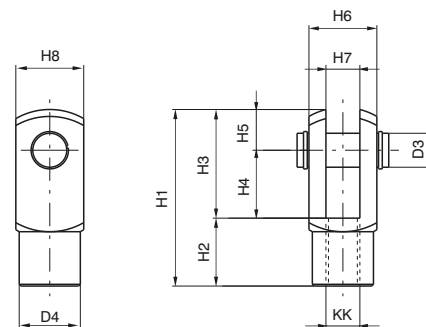

**Fork:**

Similar to hinge 03X, mounted on the rod thread, assures a regular operation even in the presence of significant forces to the linked element. Made of stainless steel AISI 304.

**Nut:**

Used to fasten flanges or feet to the endcaps of the microbore cylinder. The nuts are mounted on bores that go from 16 to 25, the lock nuts on 32. Both are supplied (one piece) with the microbore cylinders.

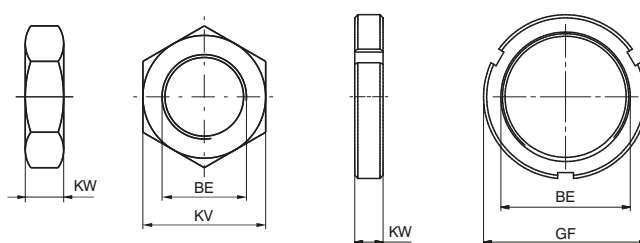

Bore	Weight g fork	Weight g nut	D3	D4	H1	H2	H3	H4	H5	H6	H7 (B12)	H8	KK	BE	KV	GF	KW
16	20	16	6	10	31	12	19	12	7	12	6	12	M6X1	M16X1,5	22	-	6
20	45	25	8	14	42	16	26	16	10	16	8	16	M8X1,25	M22X1,5	30	-	7
25	90	25	10	18	52	20	32	20	12	20	10	20	M10X1,25	M22X1,5	30	-	7
32	90	42	10	18	52	20	32	20	12	20	10	20	M10X1,25	M30X1,5	-	42	8



## Series 1303-1304-1305-1306-1307-1308

### General

They conform to CNOMO standards, fully complying with CETOP and ISO standards, with mounted fixing devices 32 to 100.

### Construction characteristic

End caps	solid aluminium bar up to Ø100, alloy aluminium from Ø125 to Ø200
Rod	C43 chromed steel, by thickness or stainless steel
Barrel	oxidised aluminium
Tie rods	steel with rolled threads
Cushion bearings	aluminium
Rod-guide bushing	brass (Ø32, 40, 50) in aluminium with self-lubricating bearings in sinterized bronze for the remaining BOREs
Piston	aluminium lathed from bar
Seals	Standard: NBR Oil resistant rubber, PUR Piston rod seals (FPM seals available upon request)

### Operational characteristics

Fluid	filtered and lubricated air - hydraulic oil (with special bushing)
Pressure	max. 12 bar (air) - 20 bar (oil)
Operating temperature	-5 °C - +70 °C with 1303-1308 standard seals -5 °C - +80 °C with FPM seals for 1306-1308 series (magnetic piston) -5 °C - +150 °C with FPM seals for 1303-1305 series (non magnetic piston)
Cushioning length	Ø $\frac{32}{20}$ - $\frac{40}{20}$ - $\frac{50}{22}$ - $\frac{63}{24}$ - $\frac{80}{24}$ - $\frac{100}{25}$ - $\frac{125}{27}$ - $\frac{160}{35}$ - $\frac{200}{35}$

Please follow the suggestions below to ensure a long life for these cylinders:

- use clean and lubricated air
- correct alignment during assembly with regard to the applied load so as to avoid radial components or bending the rod.
- avoid high speeds together with long strokes and heavy loads: this would produce kinetic energy which the cylinder cannot absorb, especially if used as a limit stop (in this case use mechanical stop device)
- evaluate the environmental characteristics of cylinder used (high temperature, hard atmosphere, dust, humidity etc.)

**Please note: air must be dried for applications with lower temperature.**

Use hydraulic oils H class (ISO VG32) for correct continued lubrication.  
Our Technical Department will be glad to help.

### Standard strokes

#### Double acting version

From 0 to 150 every 25 mm; from 150 to 500 every 50 mm; from 500 to 1000 every 100 mm (for all bores)  
On request are available strokes up to 2800 mm

#### Single acting version

up to stroke 50 mm

### Minimum and maximum springs load for single acting version

Bore	Ø32	Ø40 - Ø50	Ø63	Ø80 - Ø100
Min. load (N)	20	25	50	100
Max. load (N)	55	80	115	200

Basic version

Ordering code
<b>Non magnetic piston</b>
1303.Ø.stroke.01A (CNOMO)
1304.Ø.stroke.01A (CETOP)
1305.Ø.stroke.01A (ISO)
<b>Magnetic piston</b>
1306.Ø.stroke.01A (CNOMO)
1307.Ø.stroke.01A (CETOP)
1308.Ø.stroke.01A (ISO)

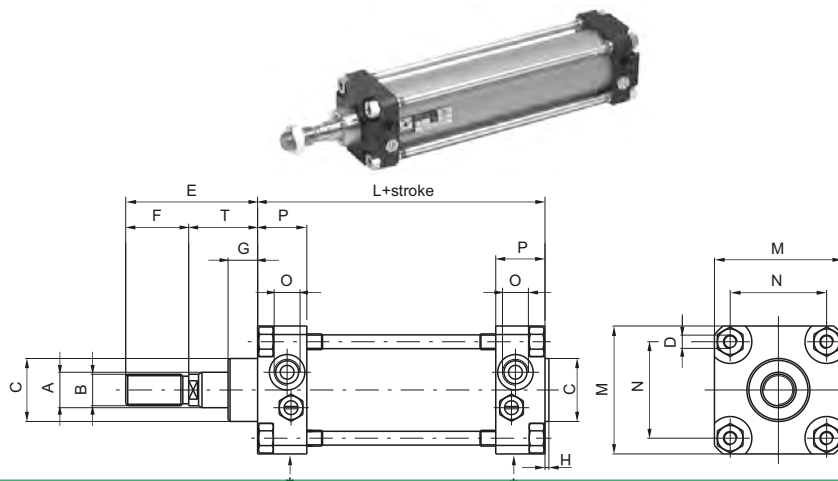

Through rod cylinder version

Ordering code
<b>Non magnetic piston</b>
1303.Ø.stroke.02A (CNOMO)
1304.Ø.stroke.02A (CETOP)
1305.Ø.stroke.02A (ISO)
<b>Magnetic piston</b>
1306.Ø.stroke.02A (CNOMO)
1307.Ø.stroke.02A (CETOP)
1308.Ø.stroke.02A (ISO)

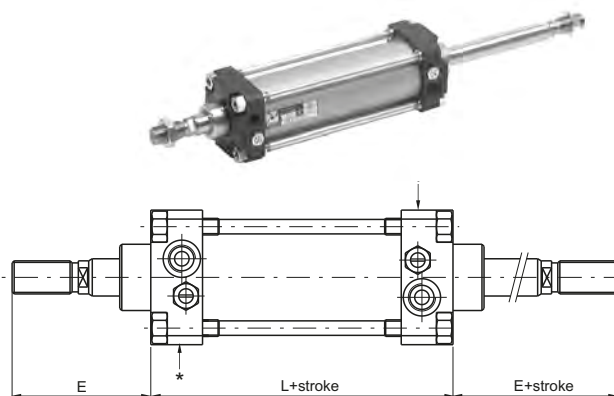

Tandem push with a common rod

Ordering code
<b>Non magnetic piston</b>
1303.Ø.stroke.H (CNOMO)
1304.Ø.stroke.H (CETOP)
1305.Ø.stroke.H (ISO)
<b>Magnetic piston</b>
1306.Ø.stroke.H (CNOMO)
1307.Ø.stroke.H (CETOP)
1308.Ø.stroke.H (ISO)

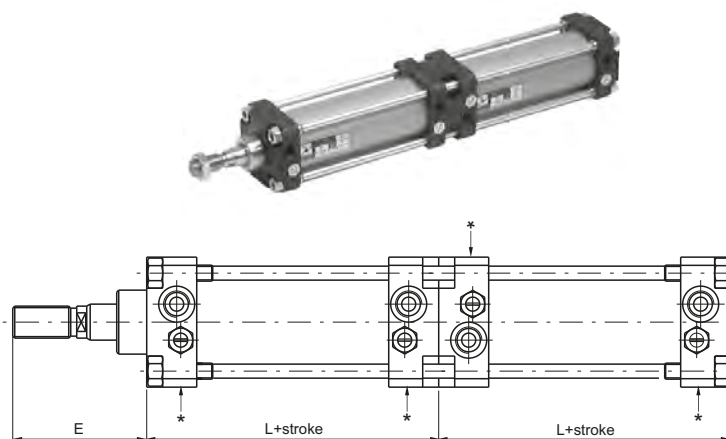

Tandem push with independent rods

Ordering code
<b>Non magnetic piston</b>
1303.Ø.stroke.stroke1.N (CNOMO)
1304.Ø.stroke.stroke1.N (CETOP)
1305.Ø.stroke.stroke1.N (ISO)
<b>Magnetic piston</b>
1306.Ø.stroke.stroke1.N (CNOMO)
1307.Ø.stroke.stroke1.N (CETOP)
1308.Ø.stroke.stroke1.N (ISO)

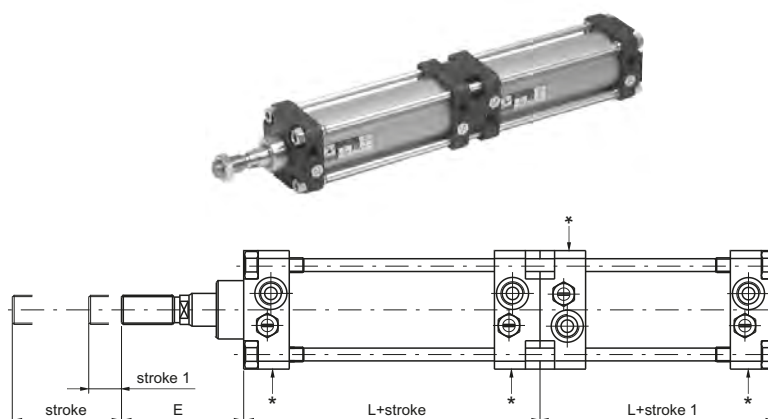

► **Opposed tandem with common rods**

Ordering code
<b>Non magnetic piston</b>
1303.Ø.stroke.stroke1.R (CNOMO)
1304.Ø.stroke.stroke1.R (CETOP)
1305.Ø.stroke.stroke1.R (ISO)
<b>Magnetic piston</b>
1306.Ø.stroke.stroke1.R (CNOMO)
1307.Ø.stroke.stroke1.R (CETOP)
1308.Ø.stroke.stroke1.R (ISO)

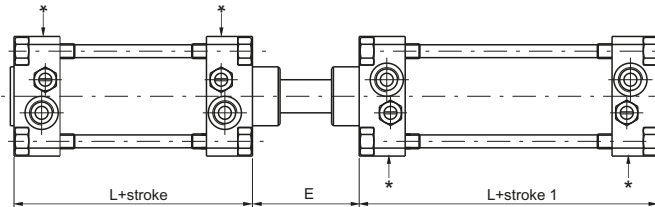

► **Tandem with opposed rods**

Ordering code
<b>Non magnetic piston</b>
1303.Ø.stroke.stroke1.U (CNOMO)
1304.Ø.stroke.stroke1.U (CETOP)
1305.Ø.stroke.stroke1.U (ISO)
<b>Magnetic piston</b>
1306.Ø.stroke.stroke1.U (CNOMO)
1307.Ø.stroke.stroke1.U (CETOP)
1308.Ø.stroke.stroke1.U (ISO)

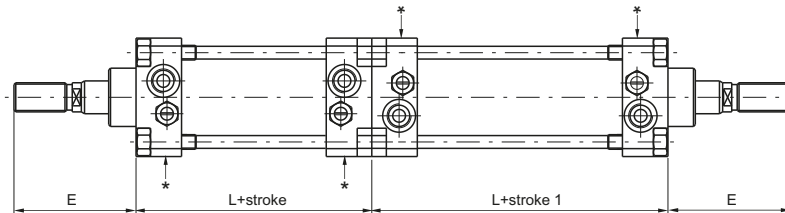

**Variants**

Add "X" to the cylinder code to order cylinders with STAINLESS STEEL rods. Example: **1303.32.250.01AX**.

Add "V" to the cylinder code to order cylinders with FPM seals. Example: **1303.32.250.01AV**.

Add "MA" to the cylinder code to order cylinders single acting front spring, with strokes not superior to 50. Example: **1303.32.50.01AMA**.

Add "MP" to the cylinder code to order cylinders single acting rear spring, with strokes not superior to 50. Example: **1303.50.25.01AMP**.

**Note:** Cushion adjustment (for Ø 32, Ø 40, Ø 125, Ø 160 and Ø 200) is on the side indicated by ★ (see drawings).

**Table of dimensions**

Bore	32	40	50	63	80	100	125	160	200
A (f7)	12	18	18	22	22	30	30	40	40
B - CNOMO (6g)	M10x1,5	M16x1,5	M16x1,5	M20x1,5	M20x1,5	M27x2	M27x2	M36x2	M36x2
B - CETOP (6g)	M10x1,25	M12x1,25	M16x1,5	M16x1,5	M20x1,5	M20x1,5	M24x2	M36x2	M36x2
B - ISO (6g)	M10x1,25	M12x1,25	M16x1,5	M16x1,5	M20x1,5	M20x1,5	M27x2	M36x2	M36x2
C (d11)	25	32	32	45	45	55	55	65	65
H	2,5	2	2	2	2	2	3	3	3
D	M6	M6	M8	M8	M10	M10	M12	M16	M16
E - CNOMO	45	70	70	85	85	110	110	135	135
E - CETOP	44	52	67	67	82	87	109	152	162
E - ISO	46	52	67	67	82	87	115	152	162
F - CNOMO	20	36	36	46	46	63	63	85	85
F - CETOP	20	24	32	32	40	40	48	72	72
F - ISO	22	24	32	32	40	40	54	72	72
G	15	15	15	20	20	20	20	25	25
M	45	52	65	75	95	115	140	180	220
N	33	40	49	59	75	90	110	140	175
O	G 1/8"	G 1/4"	G 1/4"	G 3/8"	G 3/8"	G 1/2"	G 1/2"	G 3/4"	G 3/4"
P	16	23	25	31	31	35	36	45	45
T - CNOMO	25	34	34	39	39	47	47	50	50
T - CETOP-ISO	24	28	35	35	42	47	61	80	90
L - CNOMO (±1)	80	110	110	125	125	145	145	180	180
L - CETOP-ISO (±1)	98	110	110	125	136	145	168	180	190

STROKE TOLERANCE: + 2 mm.

**WEIGHT IN g OF THE CYLINDERS WITH VARIOUS BARRELS (BASIC VERSION)**

Bore		32	40	50	63	80	100	125	160	200
Aluminium	stroke 0	580	1010	1350	2110	3350	5400	7450	13300	18300
	every 10 mm	24	38	47	63	75	117	130	235	250

FOR CYLINDERS IN TANDEM THE WEIGHT IS APPROXIMATELY DOUBLE

► **Sensor brackets codes - 1500.\_, RS.\_, HS.\_**

Ordering code	1306.A				1306.B			1306.C	
	Ø32	Ø40	Ø50	Ø63	Ø80	Ø100	Ø125	Ø160	Ø200
Bore	Ø32	Ø40	Ø50	Ø63	Ø80	Ø100	Ø125	Ø160	Ø200
L	59	65	76	87	103	121	144	179	215

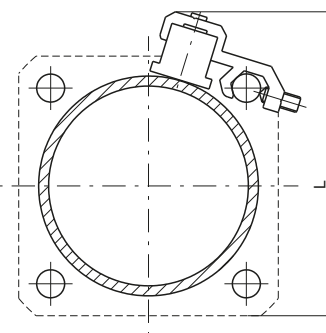

**Sensor for microbore cylinders**

For technical characteristics and ordering codes see Chapter 6 (magnetic sensors)

This accessory allows valves or solenoid valves to mount on the side of the cylinder. Support should be anchored to the tie rods and on it either a threaded distributor can be mounted or a base upon which an ISO distributor can be mounted. Once installed the connections must be done with fittings and pipes. All of the threaded holes on the support plate are dedicated to different valves series as per attached drawing.

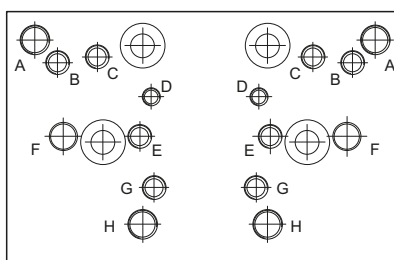

Fixing holes for valves series:

- A = 414/2
- B = 824
- C = 828, T488, 488, 484
- D = 2400
- E = 2600
- F = Bases for ISO distributors
- G = 858/2
- H = T424

► **Support**

Ordering code
<b>1306.15</b> (Ø32 ... Ø100)

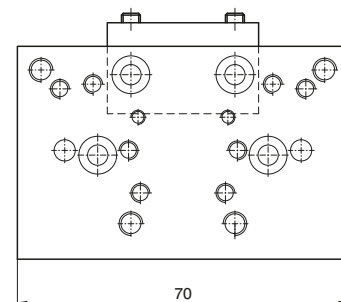
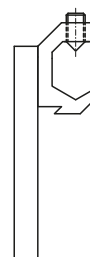

► **Bases for ISO solenoid valves**

Ordering code
<b>1320.21</b> bases for ISO 1 solenoid valves
<b>1320.22</b> bases for ISO 2 solenoid valves

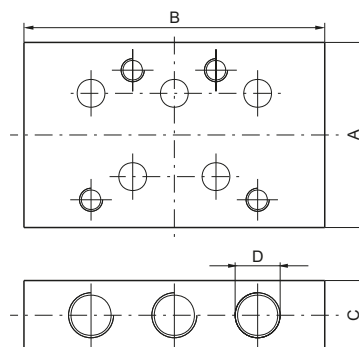

	Dimensions			
	A	B	C	D
bases for ISO 1 solenoid valves	40	75	15	G 1/8"
bases for ISO 2 solenoid valves	50	95	20	G 1/4"



**Front and rear flanges**

Ordering code

**1303.Ø.03F**  
(CNOMO)  
**1304.Ø.03F**  
(CETOP - ISO)

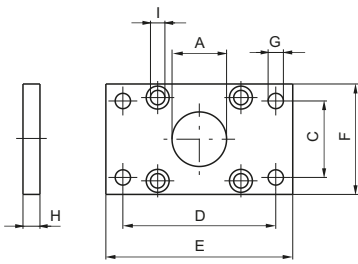
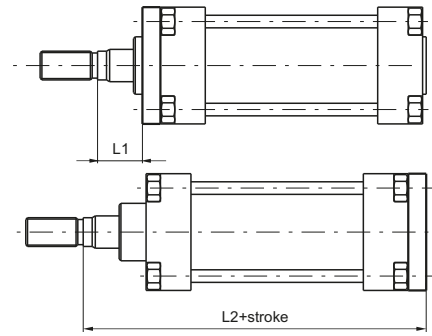

Plate which allows anchorage of the cylinder at a right angle to the plane. It is made of zinc-plated extruded steel.

Bore	32	40	50	63	80	100	125	160	200
A (H11)	25	32	32	45	45	55	55	65	65
C - CNOMO (JS 14)	33	40	49	59	75	90	110	140	175
C - CETOP ISO (JS 14)	32	36	45	50	63	75	90	115	135
D - CNOMO (JS 14)	68	78	94	104	130	150	180	228	268
D - CETOP - ISO (JS 14)	64	72	90	100	126	150	180	230	270
E	80	90	110	120	150	170	205	260	300
F	45	52	65	75	95	115	140	180	220
G - CNOMO (H13)	9	9	11	11	14	14	18	22	22
G - CETOP - ISO (H13)	7	9	9	9	12	14	16	18	22
H (JS 14)	8	8	10	10	12	12	16	20	20
I	6,5	6,5	9	9	10,5	10,5	13,5	16,5	16,5
L1 - CNOMO	17	26	24	29	27	35	31	30	30
L1 - CETOP - ISO	16	20	25	25	30	35	45	60	70
L2 - CNOMO	113	152	154	174	176	204	208	250	250
L2 - CETOP - ISO	130	145	155	170	190	205	245	280	300
Weight g	165	200	540	1060	1460	1510	3100	6400	9500

**Standard feet**

Ordering code

**1303.Ø.05F**  
(CNOMO)  
(1 piece)  
**1304.Ø.05F**  
(CETOP - ISO)  
(1 piece)

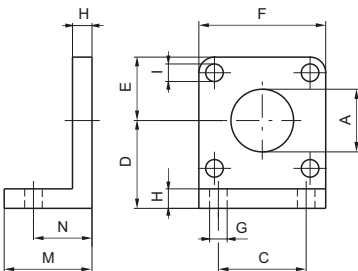
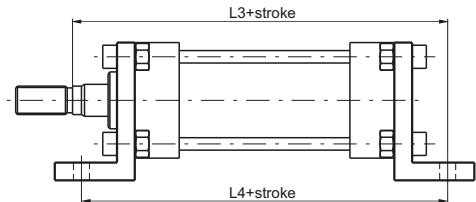

Elements used to anchor the cylinder parallel to the mounting plane. They are made of cast aluminium, painted black.

Bore	32	40	50	63	80	100	125	160	200
A (H11)	25	32	32	45	45	55	55	65	65
C - CNOMO (JS 14)	28	36	45	55	70	90	100	130	170
C - CETOP ISO (JS 14)	32	36	45	50	63	75	90	115	135
D - CNOMO (JS 15)	32	36	45	50	63	73	91	115	135
D - CETOP - ISO (JS 15)	32	36	45	50	63	71	90	115	135
E	22	26	32	37	47	57	70	90	110
F	45	52	65	75	95	115	140	180	220
G - CNOMO (H14)	9	9	11	11	14	14	18	22	22
G - CETOP (H14)	7	9	9	9	12	14	16	18	22
G - ISO (H14)	7	9	9	9	12	14	16	18	22
H	8	8	10	10	12	12	16	20	20
I	7	7	9	9	11	11	13	17	17
M	35	35	45	45	55	55	68	82	91
N - CNOMO (±0,2)	27	27	35	35	43	43	52	62	62
N - CETOP - ISO (±0,2)	22	25,5	30	30	37	37,5	41	60	65
L3 - CNOMO	132	171	179	199	207	235	244	292	292
L3 - CETOP - ISO	144	163	175	190	215	230	270	320	345
L4 - CNOMO	134	164	180	195	211	231	249	304	304
L4 - CETOP - ISO	142	161	170	185	210	220	250	300	320
Weight g	55	70	150	175	260	550	920	2200	3200

Short sheet metal feet

Ordering code  
**1303.Ø.05/1F**  
(CNOMO - CETOP - ISO)  
(1 piece)

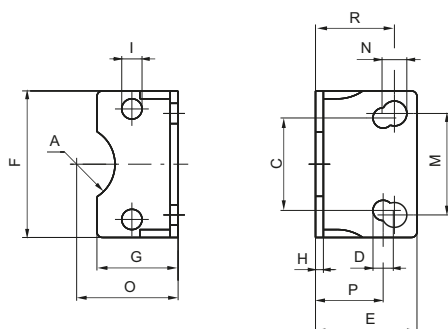
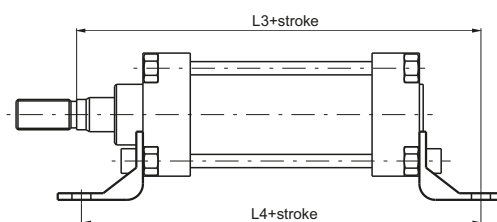

Elements used to anchor the cylinder parallel to the mounting plane. They are made of stamped and pierced sheet metal and painted in black. The mounting holes allow use with CNOMO, CETOP and ISO. Available up to 100 mm bore

Bore	32	40	50	63	80	100
A	13	17	17	23,5	23,5	-
C - CETOP - ISO (JS 14)	32	36	45	50	63	75
D - CETOP - ISO (JS 15)	7	9	9	9	12	14
E	35	36	45	45	55	56
F	45	52	65	75	95	115
G	30	30	36	35	45	44
H	3,5	3,5	3,5	4,5	5	5
I	7	7	9	9	11	11
M - CNOMO (JS 14)	28	36	45	55	70	90
N - CNOMO (JS 15)	9	9	11	11	13	13
O - CNOMO (JS 15)	32	36	45	50	63	73
O - CETOP - ISO (JS 15)	32	36	45	50	63	71
P - CETOP - ISO (±0,2)	22	25,5	30	30	37	37,5
R - CNOMO (±0,2)	27	27	35	35	43	43
L3 - CNOMO	132	171	179	199	207	235
L3 - CETOP - ISO	144	163	175	190	215	230
L4 - CNOMO	134	164	180	195	211	231
L4 - CETOP - ISO	142	161	170	185	210	220
Weight g	58	70	118	184	305	385

Large internal and external feet

Ordering code  
*Internal*  
**1303.Ø.06F**  
(CNOMO) (1 piece)  
(May be used with CETOP-ISO cylinders but are not specified in the standards)  
*External*  
**1303.Ø.07F**  
(CNOMO) (1 piece)

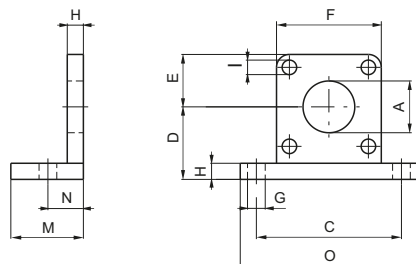
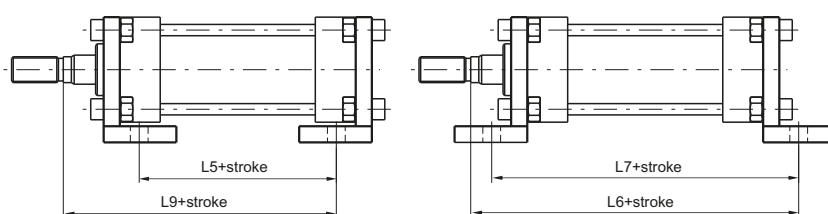

Elements used to anchor the cylinder parallel to the mounting plane. They are made of aluminium alloy and painted black.

Bore	32	40	50	63	80	100	125	160	200
A (H11)	25	32	32	45	45	55	55	65	65
C (JS 14)	65	72	90	100	126	148	180	230	270
D (JS 15)	32	36	45	50	63	73	91	115	135
E	22	26	32	37	47	57	70	90	110
F	45	52	65	75	95	115	140	180	220
G (H14)	9	9	11	11	14	14	18	22	22
H	8	8	10	10	12	12	16	20	20
I	7	7	9	9	11	11	13	17	17
M	35	35	45	45	55	55	67	80	80
N (±0,2)	18	18	22	22	28	28	32	40	40
O	82	90	110	120	155	180	215	275	315
L5 - CNOMO	60	90	86	101	93	113	113	140	140
L5 - CETOP - ISO	78	90	86	101	104	113	136	140	150
L6 - CNOMO	123	162	166	186	192	220	224	270	270
L6 - CETOP - ISO	141	162	166	186	203	220	247	270	280
L7 - CNOMO	116	146	154	169	181	201	209	260	260
L7 - CETOP - ISO	134	146	154	169	192	201	232	260	270
L9 - CNOMO	95	134	132	152	148	176	176	210	210
L9 - CETOP - ISO	112	128	133	148	162	176	213	240	250
Weight g	80	90	190	210	460	600	1080	2400	3100

**Front clevis**

Ordering code

*Front*  
**1303.Ø.08F**  
 (CNOMO)  
**1304.Ø.08F**  
 (CETOP - ISO)

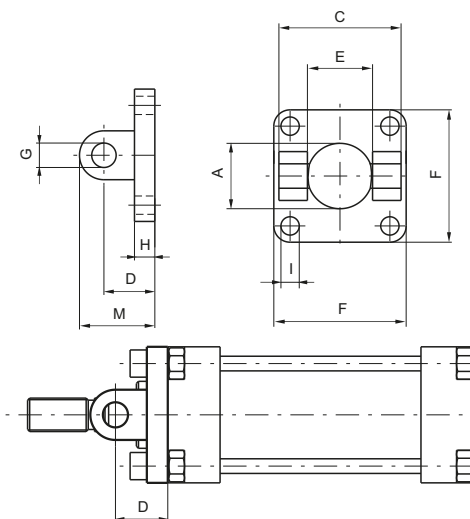

Bore	32	40	50	63	80	100	125	160	200
A	25	32	32	45	45	55	55	65	65
C - CNOMO (H1)	45	52	65	75	95	115	140	180	220
C - CETOP - ISO (H14)	45	52	60	70	90	110	130	170	170
D - CNOMO (±0,2)	18	24	26	30	32	37	41	55	55
D - CETOP (±0,2)	20	22	25	30	32	37	46	55	55
E - CNOMO (H14)	26	33	33	47	47	57	57	72	72
E - CETOP (H14)	26	28	32	40	50	60	70	90	90
F	45	52	65	75	95	115	140	180	220
G - CNOMO (H9)	8	12	12	16	16	20	20	25	25
G - CETOP - ISO (H9)	10	12	12	16	16	20	25	30	30
H	8	8	10	10	12	12	16	19	19
I	7	7	9	9	11	11	13	17	17
M - CNOMO	26	36	38	46	48	57	61	80	80
M - CETOP - ISO	30	35	37	46	48	57	71	85	85
Weight g	55	60	120	145	325	510	900	2080	3100

This type of mounting allows anchorage of the cylinder both parallel and at a right angle to the plane; the cylinder rod can oscillate and self-align as necessary. It is made of aluminium alloy and painted black.

**Rear clevis complete with pin**

Ordering code

*Rear*  
**1303.Ø.09F**  
 (CNOMO)  
**1304.Ø.09F**  
 (CETOP - ISO)

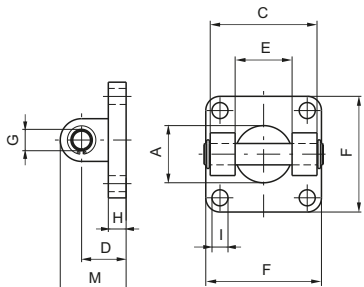
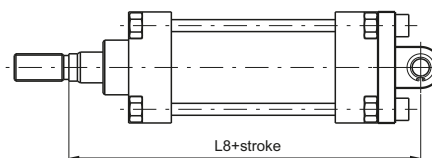

Bore	32	40	50	63	80	100	125	160	200
A	25	32	32	45	45	55	55	65	65
C - CNOMO (H1)	45	52	65	75	95	115	140	180	220
C - CETOP - ISO (H14)	45	52	60	70	90	110	130	170	170
D - CNOMO (±0,2)	18	24	26	30	32	37	41	55	55
D - CETOP - ISO (±0,2)	20	22	25	30	32	37	46	55	55
E - CNOMO (H14)	26	33	33	47	47	57	57	72	72
E - CETOP (H14)	26	28	32	40	50	60	70	90	90
F	45	52	65	75	95	115	140	180	220
G - CNOMO (H9)	8	12	12	16	16	20	20	25	25
G - CETOP - ISO (H9)	10	12	12	16	16	20	25	30	30
H	8	8	10	10	12	12	16	19	19
I	7	7	9	9	11	11	13	17	17
M - CNOMO	26	36	38	46	48	57	61	80	80
M - CETOP - ISO	30	35	37	46	48	57	71	85	85
L8 - CNOMO	123	168	170	194	196	229	233	285	285
L8 - CETOP - ISO	142	160	170	190	210	230	275	315	335
Weight g	75	110	190	280	490	820	1270	2800	3900

This type of mounting allows anchorage of the cylinder both parallel and at a right angle to the plane; the cylinder rod can oscillate and self-align as necessary. It is made of aluminium alloy and painted black.



► **Rear male clevis**

Ordering code  
**1304.Ø.09/1F**  
(For CETOP-ISO cylinders  
May be used with CNOMO cylinders but is not specified in the standards)

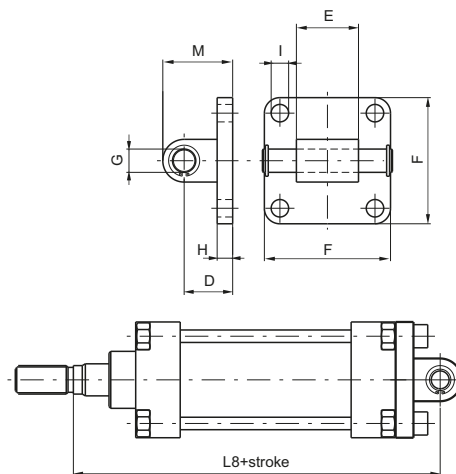

Similar to 09 clevis except for the connection, which is male rather than female. It can also be used as a counter clevis for type 10 (only CETOP - ISO). Allows mounting of cylinder at right angle to the plane of the cylinder rod.

Bore	32	40	50	63	80	100	125	160	200
D ( $\pm 0,2$ )	20	22	25	30	32	37	46	55	55
E ( $^{+0,2}_{-0,6}$ )	26	28	32	40	50	60	70	90	90
F	45	52	65	75	95	115	140	180	220
G (H 9)	10	12	12	16	16	20	25	30	30
H	8	8	8	10	12	12	16	20	20
I	7	7	9	9	11	11	14	18	18
M	30	35	36	45	47	57	71	80	80
L8 - CNOMO	125	166	169	194	196	229	233	285	285
L8 - CETOP - ISO	142	160	170	190	210	230	275	315	335
Weight g	50	80	110	185	325	460	1300	2850	3980

► **Rear clevis bracket**

Ordering code  
**1303.Ø.10F (CNOMO)**  
(May be used with CETOP - ISO cylinders but is not specified in the standard)

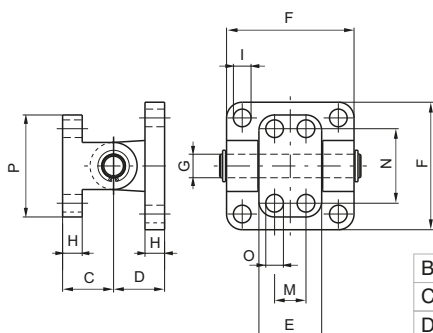
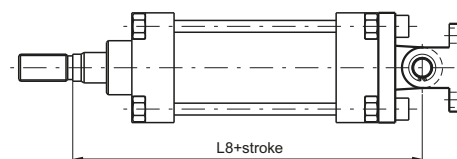

Mounting consists of clevis 09 and counter clevis. Used to mount cylinders at a right angle to the plane to which the counter clevis is attached. Allows self-alignment of the cylinder rod under load with an oscillation of  $\pm 60$  degrees.

Bore	32	40	50	63	80	100	125	160	200
C ( $\pm 0,2$ )	18	26	26	34	34	41	41	55	55
D ( $\pm 0,2$ )	18	24	26	30	32	37	41	55	55
E	25	32	32	46	46	56	56	71	71
F	45	52	65	75	95	115	140	180	220
G (H 9)	8	12	12	16	16	20	20	25	25
H	8	10	10	12	12	16	16	20	20
I	7	7	9	9	11	11	13	17	17
M (JS 14)	-	16	16	25	25	32	32	43	43
N (JS 14)	28	38	38	54	54	90	90	150	150
O (H 13)	7	9	9	11	11	14	14	18	18
P	40	52	52	75	75	115	115	180	180
L8 - CNOMO	123	168	170	194	196	229	233	285	285
L8 - CETOP - ISO	140	162	171	190	210	229	270	315	335
Weight g	90	165	240	470	665	1190	1660	3700	4700

**Trunnion with support bracket**

Ordering code

**1303.Ø.11F (CNOMO)**  
 (May be used with  
 CETOP - ISO  
 cylinders but  
 is not specified  
 in the standards)

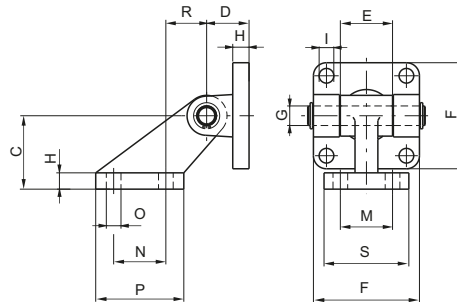
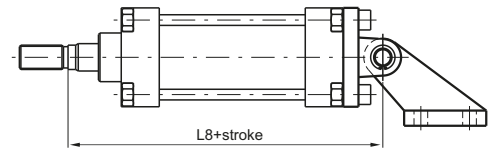

Bore	32	40	50	63	80	100	125	160	200
C (JS 15)	32	45	45	63	63	90	90	140	140
D (±0,2)	18	24	26	30	32	37	41	55	55
E	25	32	32	46	46	56	56	71	71
F	45	52	65	75	95	115	140	180	220
G (H9)	8	12	12	16	16	20	20	25	25
H	8	10	10	12	12	16	16	20	20
I	7	7	9	9	11	11	13	17	17
M (JS14)	25	32	32	40	40	50	50	63	63
N (Js14)	20	32	32	50	50	70	70	110	110
O (JS 13)	7	9	9	11	11	14	14	18	18
P	37	54	54	75	75	102	102	154	154
R	18	25	25	32	32	40	40	50	50
S	41	51	51	62	62	80	80	110	110
L8 - CNOMO	123	168	170	194	196	229	233	285	285
L8 - CETOP - ISO	140	162	171	190	210	229	270	315	335
Weight g	125	250	325	600	800	1570	2100	4600	5700

Mounting consists of clevis 09 and right angle counter clevis. Used to mount cylinders parallel to the plane to which the counter clevis is attached. Allows self-alignment of the cylinder rod under load with an oscillation up to 90 degrees from the mounting plane.

**Intermediate trunnion**

Ordering code

**1300.Ø.12F**

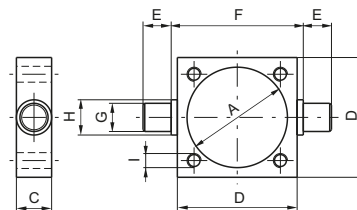
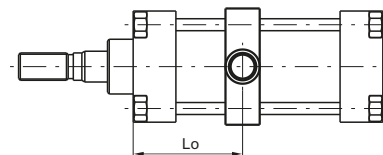

Bore	32	40	50	63	80	100	125	160	200
A	37	46	56	69	87	107	133	170	211
C	15	20	20	25	25	30	32	40	40
D	46	59	69	84	102	125	155	190	240
E (h 14)	12	16	16	20	20	25	25	32	32
F (h 14)	50	63	73	90	108	131	160	200	250
G (e 9)	12	16	16	20	20	25	25	32	32
H	15	20	20	25	25	30	30	40	40
I	M6	M6	M8	M8	M10	M10	M12	M16	M16
Lo min.	32	35	40	47	53	55	61	78	79
Lo max. + stroke - CNOMO	48	75	70	80	72	90	84	103	102
Lo max. + stroke - CETOP - ISO	67	75	70	80	84	90	107	103	112
Weight g	130	310	370	700	900	1590	2600	4300	7500

Clevis to be mounted between the endcaps of the cylinder allowing rotation at any point along the barrel. One piece construction from zinc-plated stamped steel. Can be mounted in fixed position or attached to adjustable tie rods.  
 NOTE: Lo max means at stroke 0.

**Fork with pin**

Ordering code  
**1300.Ø.13F (CNOMO)**  
**1301.Ø.13F (CETOP)**  
**1302.Ø.13F (ISO)**

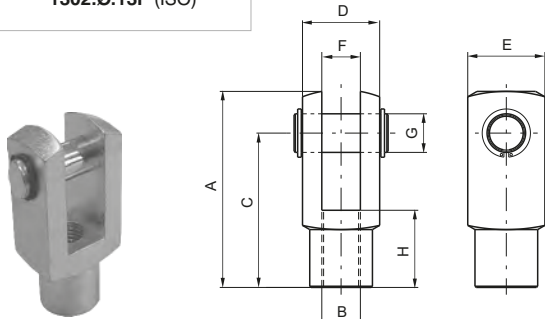

**Male fork**

Ordering code  
**1300.Ø.14F**  
(only for CNOMO cylinders)

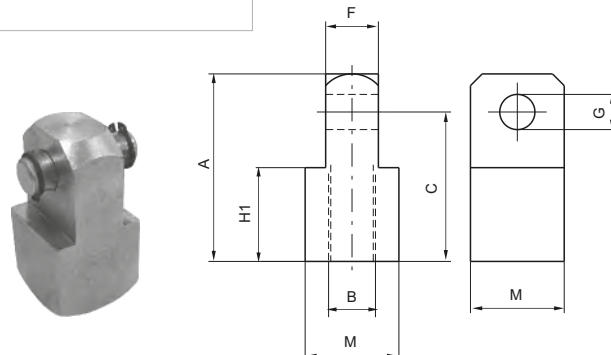

**Fork with clips**

Ordering code  
**1300.Ø.13/1F (CNOMO)**  
**1301.Ø.13/1F (CETOP)**  
**1302.Ø.13/1F (ISO)**

from Ø32 to Ø100 mm

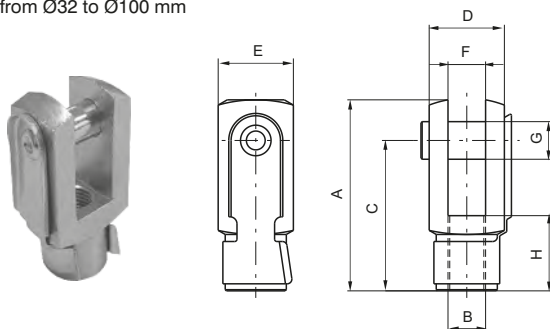

**Rod lock nut**

Ordering code  
**1300.Ø.18F (CNOMO)**  
**1301.Ø.18F (CETOP)**  
**1302.Ø.18F (ISO)**

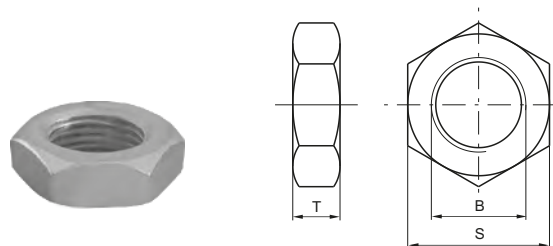

**3**  
**PNEUMATIC ACTUATION**

Bore	32	40	50	63	80	100	125	160	200	
A - CNOMO	45	64	64	80	80	105	105	140	140	
A - CETOP - ISO	51	62	82	82	105	105	132/148	188	188	
B - CNOMO (6H)	M10x1,5	M16x1,5	M16x1,5	M20x1,5	M20x1,5	M27x2	M27x2	M36x2	M36x2	
B - CETOP (6H)	M10x1,25	M12x1,25	M16x1,5	M16x1,5	M20x1,5	M20x1,5	M24x2	M36x2	M36x2	
B - ISO (6 H)	M10x1,25	M12x1,25	M16x1,5	M16x1,5	M20x1,5	M20x1,5	M27x2	M36x2	M36x2	
C - CNOMO	36	51	51	63	63	85	85	115	115	
C - CETOP - ISO	40	48	64	65	80	80	100/100	144	144	
D - CNOMO	22	36	36	45	45	63	63	80	80	
D - CETOP - ISO	20	24	32	32	40	40	50/55	70	70	
E - CNOMO	22	26	26	34	34	42	42	50	50	
E - CETOP - ISO	20	24	32	32	40	40	50/55	70	70	
F - CNOMO (H 14)	11	18	18	22	22	30	30	40	40	
F - CETOP - ISO (B 12)	10	12	16	16	20	20	25/30	35	35	
G - CNOMO (H 9)	8	12	12	16	16	20	20	25	25	
G - CETOP - ISO (H 9)	10	12	16	16	20	20	25/30	35	35	
H - CNOMO	20	26	26	30	30	45	45	75	75	
H - CETOP - ISO	20	24	32	32	40	40	50/56	72	72	
H1 - CNOMO	20	32	32	40	40	55	55	75	75	
M	22	32	32	36	36	45	45	70	70	
S - CNOMO	17	24	24	30	30	41	41	55	55	
S - CETOP	17	19	24	24	30	30	36	55	55	
S - ISO	17	19	24	24	30	30	41	55	55	
T - CNOMO	6	8	8	9	9	12	12	18	18	
T - CETOP	6	7	8	8	9	9	10	18	18	
T - ISO	6	7	8	8	9	9	12	18	18	
Weight g										
	Fork	90	150	350	350	680	680	2500	4000	4000
	Rod lock nut	10	20	20	35	35	80	80	210	210
	Male fork	110	30	330	500	500	1300	1300	3500	3500



## Series 1319-1320-1321

### General

This series of pneumatic cylinders is manufactured according to ISO 6431 standards adapted to VDMA 24562 and CNOMO/AFNOR 49003 that guarantee the interchangeability of the cylinders even without mounted anchoring.

### Construction characteristics

End caps	from Ø32 to Ø125: UNI 5079 aluminium alloy casting painted black by cataphoresis from Ø160 to Ø200: UNI 3051 aluminium chilled painted black by cataphoresis
Rod	stainless steel or C43 chromed steel
Barrel	oxidised aluminium
Cushion bushings	hardened aluminium
Rod-guide bushing	self-lubricating sintered bronze
Piston	vulcanized rubber block on steel core with incorporated plastoferrite permanent magnet, or without magnet for non magnetic version (plus rear spacer).
Seals	standard: NBR Oil resistant rubber, PUR Piston rod and cushion seals (FPM seals available upon request)
Cushion adjustment screws	brass

### Operational characteristics

Fluid	Filtered air. No lubrication needed, if applied it shall be continuous.
Pressure	max. 10 bar
Operating temperature	-5 °C - +70 °C with standard seals (magnetic or non magnetic piston) -5 °C - +80 °C with FPM seals for 1319 and 1320 series (magnetic piston) -5 °C - +150 °C with FPM seals for 1321 series (non magnetic piston)
Cushioning length	Ø 32 - 40 - 50 - 63 - 80 - 100 - 125 - 160 - 200 mm 28 - 32 - 32 - 40 - 44 - 50 - 55 - 55 - 55

Please follow the suggestions below to ensure a long life for these cylinders:

- use clean and lubricated air
- correct alignment during assembly with regard to the applied load so as to avoid radial components or bending the rod.
- avoid high speeds together with long strokes and heavy loads: this would produce kinetic energy which the cylinder cannot absorb, especially if used as a limit stop (in this case use mechanical stop device)
- evaluate the environmental characteristics of cylinder used (high temperature, hard atmosphere, dust, humidity etc.)

**Please note: air must be dried for applications with lower temperature.**

Use hydraulic oils H class (ISO VG32) for correct continued lubrication.

Our Technical Department will be glad to help.

#### Standard strokes (for all diameters)

##### Double acting version

from 0 to 150, every 25 mm
over 150 up to 500, every 50 mm
over 500 up to 1000, every 100 mm

On request are available strokes up to 2800 mm

##### Single acting version

From Ø32 to Ø125, up to stroke 50 mm

On request are available strokes up to 200 mm

#### Stroke tolerance (ISO 15552)

Bore	Stroke	Tolerance
32 - 40 - 50	up to 500	+2 0
	over 500 up to 1250	+3,2 0
63 - 80 - 100	up to 500	+2,5 0
	over 500 up to 1250	+4 0
125 - 160 - 200	up to 500	+4 0
	over 500 up to 1250	+5 0

### Minimum and maximum springs load for single acting version

Bore	Ø32	Ø40	Ø50 - Ø63	Ø80 - Ø100	Ø125
Min. load (N)	15	25	50	100	150
Max. load (N)	40	80	115	200	250

► **Basic version "01"**

Ordering code
1319.Ø.stroke.01 magnetic chromed rod
1320.Ø.stroke.01 magnetic stainless steel rod
1321.Ø.stroke.01 non magnetic chromed rod
13--Ø.stroke.01V FPM seals
13--Ø.stroke.01MA Front springs (Ø32-Ø125)*
13--Ø.stroke.01MP Rear springs (Ø32-Ø125)*

\* Max. stroke 50

This is the configuration that represents the basic cylinder according to ISO-VDMA standards. It can be directly anchored on machine parts using the four thread on the end cap. For other applications see the following pages where different types of attachments are shown.

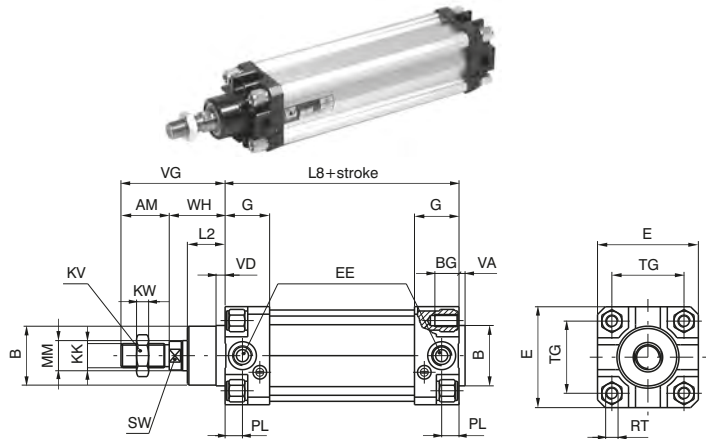

► **Through rod cylinder version "02"**

Ordering code
1319.Ø.stroke.02 magnetic chromed rod
1320.Ø.stroke.02 magnetic stainless steel rod
1321.Ø.stroke.02 non magnetic chromed rod
13--Ø.stroke.02V FPM seals

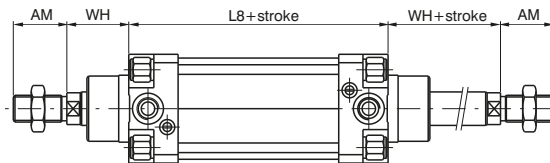

► **Tandem push with a common rods "G"**

Ordering code
1319.Ø.stroke.G magnetic chromed rod
1320.Ø.stroke.G magnetic stainless steel rod
1321.Ø.stroke.G non magnetic chromed rod

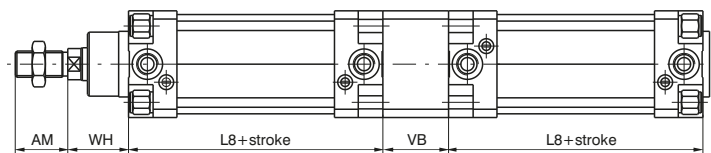

► **Tandem push with independent rods "F"**

Ordering code
1319.Ø.stroke.stroke1.F magnetic chromed rod
1320.Ø.stroke.stroke1.F magnetic stainless steel rod
1321.Ø.stroke.stroke1.F non magnetic chromed rod

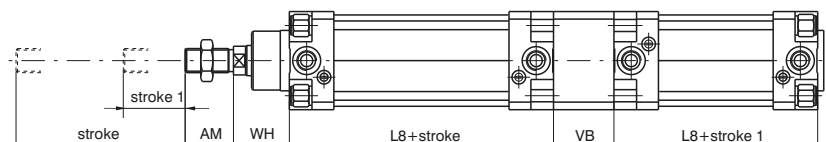

### Opposed tandem with common rod "D"

Ordering code

1319.Ø.stroke.stroke1.D magnetic chromed rod  
1320.Ø.stroke.stroke1.D magnetic stainless steel rod  
1321.Ø.stroke.stroke1.D non magnetic chromed rod

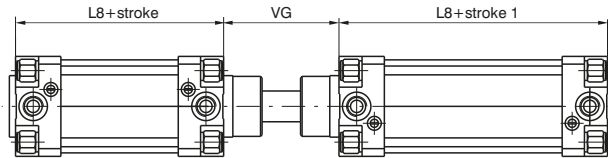

### Tandem with opposed rods "E"

Ordering code

1319.Ø.stroke.stroke1.E magnetic chromed rod  
1320.Ø.stroke.stroke1.E magnetic stainless steel rod  
1321.Ø.stroke.stroke1.E non magnetic chromed rod

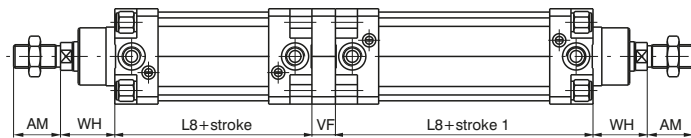

Table of dimensions

Bore	32	40	50	63	80	100	125	160	200	
AM	22	24	32	32	40	40	54	72	72	
B (d 11)	30	35	40	45	45	55	60	65	75	
BG	14	14	16	16	21	21	23	24	24	
E	46	52	65	75	95	115	140	180	220	
EE	G 1/8"	G 1/4"	G 1/4"	G 3/8"	G 3/8"	G 1/2"	G 1/2"	G 3/4"	G 3/4"	
G	25	29	29,5	36	36	40	45	49	49	
KK	M10X1,25	M12X1,25	M16x1,5	M16x1,5	M20x1,5	M20x1,5	M27x2	M36x2	M36x2	
KV	17	19	24	24	30	30	41	55	55	
KW	6	7	8	8	9	9	12	18	18	
L2	16	20	25	25	32	35	45	50	60	
L8 *	94	105	106	121	128	138	160	180	180	
MM	12	16	20	20	25	25	32	40	40	
PL	9	11,5	13	14	16	18	19	24	25	
RT	M6	M6	M8	M8	M10	M10	M12	M16	M16	
SW	10	13	17	17	22	22	27	32	32	
TG	32,5	38	46,5	56,5	72	89	110	140	175	
VA	4	4	4	4	4	4	6	5	5	
VB	25	30	40	40	50	50	75	70	75	
VD	5	6	6	6	10	10	12	10	10	
VF	12	12	16	16	20	20	25	30	30	
VG	48	54	69	69	86	91	119	152	167	
WH	26	30	37	37	46	51	65	80	95	
Weight g	Stroke 0	480	730	1150	1600	2800	3600	7800	15000	21500
	every 10 mm	25	32	56	60	90	100	140	265	325

\* For strokes over 50mm, the length does not increase proportionally to the stroke, and allowance must be made for adequate spring allocation (see table of L8 dimensions).

#### "L8" dimensions for "rear spring" and "front spring"

Bore	32	40	50	63	80	100	125
L8 (Stroke 51 ÷ 100)	134	150	151	166	183	193	230
L8 (Stroke 101 ÷ 150)	174	195	196	211	238	248	300
L8 (Stroke 151 ÷ 200)	214	240	241	256	293	303	370



## Series 1348-1349-1350, Non rotating cylinders

### Construction characteristics

End caps	UNI 5079 aluminium alloy casting painted black by cataphoresis
Rod	C43 chromed steel Ra = 0.2
Barrel	UNI 9006/1 aluminium alloy square section, hardened 30 micron oxidate
Cushion bushings	2011 UNI 9002/5 hardened alloy aluminium
Piston	polyacetal resin, self-lubricated and anti-wear, with plastoferrite rings in magnetic version
Piston seals	NBR oil-resistant rubber, PUR Piston rod and cushion seals
Cushioning adjustment screw	brass

### Technical characteristics

Fluid	Filtered air. No lubrication needed, if applied it shall be continuous.
Pressure	10 bar
Operating temperature	-5°C - +70°C

Please follow the suggestions below to ensure a long life for these cylinders:

- use clean and lubricated air
- correct alignment during assembly with regard to the applied load so as to avoid radial components or bending the rod.
- avoid high speeds together with long strokes and heavy loads: this would produce kinetic energy which the cylinder cannot absorb, especially if used as a limit stop (in this case use mechanical stop device)
- evaluate the environmental characteristics of cylinder used (high temperature, hard atmosphere, dust, humidity etc.)

**Please note: air must be dried for applications with lower temperature.**

Use hydraulic oils H class (ISO VG32) for correct continued lubrication.

Our Technical Department will be glad to help.

Bore	Usable surface (square profile) cm <sup>2</sup>	Max couple on the rod (max torque) Nm	Grade precision (rest rod, without load) anti-rotation	Cushion length mm.
32	8.31	0.5	12'	22
40	12.41	0.8	12'	27
50	18.41	1.1	12'	27
63	29.67	1.5	12'	32

### Standard strokes (for all diameters)

from 0 to 150, every 25 mm

#### Other stroke for these following bores:

- Ø 32 80 mm
- Ø 40 80 - 160 mm
- Ø 50 80 - 160 - 200 - 250 mm
- Ø 63 80 - 160 - 200 - 300 - 320 mm

On request are available strokes up to 1000 mm

### Stroke Tolerance (ISO 15552)

Bore	Stroke	Tolerance
32 - 40 - 50 - 63	up to 500	+2 0

**Basic version**

Ordering code

- 1348.Ø.stroke.01**  
magnetic chromed rod
- 1349.Ø.stroke.01**  
magnetic stainless steel rod
- 1350.Ø.stroke.01**  
non-magnetic chromed rod

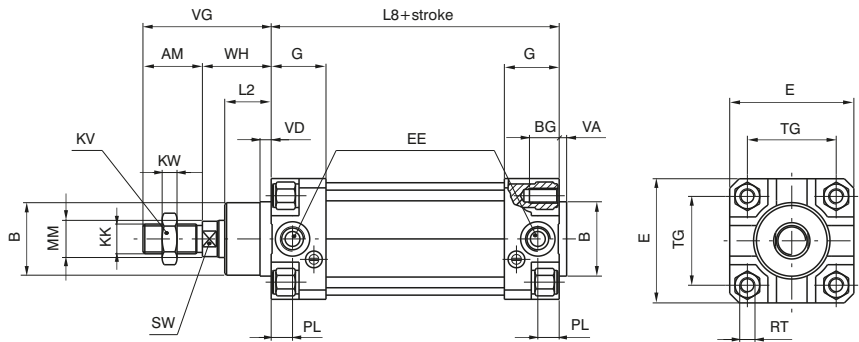

Bore	32	40	50	63	
AM	22	24	32	32	
B (d 11)	30	35	40	45	
BG	12	12	16	16	
E	46	52	65	75	
EE	G 1/8"	G 1/4"	G 1/4"	G 3/8"	
G	25	29	29,5	36	
KK	M10x1,25	M12x1,25	M16x1,5	M16x1,5	
KV	17	19	24	24	
KW	6	7	8	8	
L 2	16	20	25	25	
L 8	94	105	106	121	
MM	12	16	20	20	
PL	9	11,5	13	14	
RT	M6	M6	M8	M8	
SW	10	13	17	17	
TG	32,5	38	46,5	56,5	
VA	4	4	4	4	
VD	5	6	6	6	
VG	48	54	69	69	
WH	26	30	37	37	
Weight	stroke 0	505	705	1320	1710
g	every 10 mm	24	33	53	58

This is the configuration that represents the basic cylinder according to ISO standards. It can be directly anchored on machine parts using the four threads on the end cap. For other applications see the following pages where different types of attachments shown.

**Through rod cylinder version**

Ordering code

- 1348.Ø.stroke.02**  
magnetic chromed rod
- 1349.Ø.stroke.02**  
magnetic stainless steel rod
- 1350.Ø.stroke.02**  
non-magnetic chromed rod

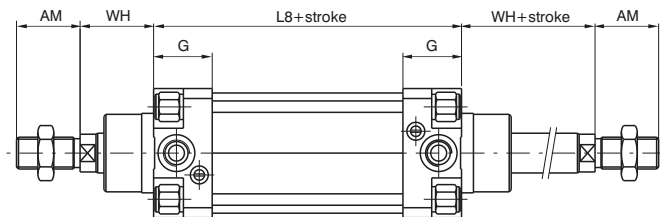



► **Sensor brackets**

Sensor brackets codes 1500._, RS._, HS._	Sensor brackets codes 1595.HAP	Bore	L
Code	Code		
1320.A	1320.ASC	Ø32	60
		Ø40	65
1320.B	1320.BSC	Ø50	77
		Ø63	87
1320.C	1320.CSC	Ø80	105
		Ø100	125
1320.D	1320.DSC	Ø125	145
1320.E	1320.ESC	Ø160	184
1320.F	1320.FSC	Ø200	222

Sensor brackets codes 1580._, MRS._, MHS._		
Code	Bore	L1
1320.AS	Ø32	48
	Ø40	54
1320.BS	Ø50	66
	Ø63	76
1320.CS	Ø80	96
	Ø100	112
1320.DSC	Ø125	145
1320.ESC	Ø160	184
1320.FSC	Ø200	222

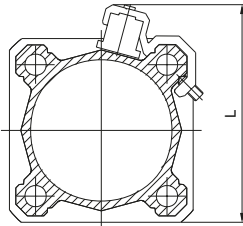

Sensors 1500.\_,RS.\_,HS.\_

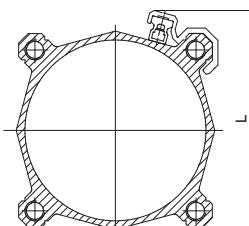

Sensors 1595.HAP

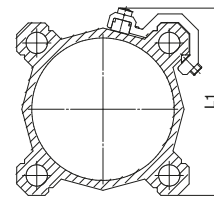

Sensors 1580.\_, MRS.\_, MHS.\_

**Sensors for microbore cylinders:** for technical characteristics and ordering codes see "Magnetic sensors" section

► **Solenoid valves supports**

This accessory permits to mount a valve or an electrovalve on a side of the cylinder. The plate can be fitted on the cylinder profiled barrel, and, on it, can be mounted either a threaded distributor or a base on which can be mounted an ISO distributor. Once installed the connections must be done with fittings and pipes. All of the threaded holes on the support plate are dedicated to different valves series as per attached drawing.

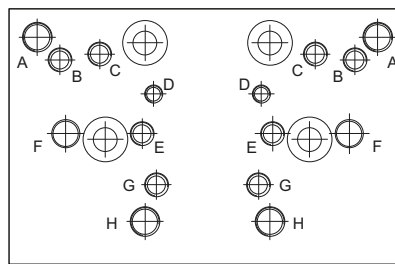

Fixing holes for valves series:

- A = 414/2
- B = 824
- C = 828, T488, 488, 484
- D = 2400
- E = 2600
- F = Bases for ISO distributors
- G = 858/2
- H = T424

Ordering code
1320.15 (Ø32 - Ø40)
1320.16 (Ø50 - Ø63)
1320.17 (Ø80 - Ø100)
1320.18 (Ø125)
1320.19 (Ø160)
1320.20 (Ø200)

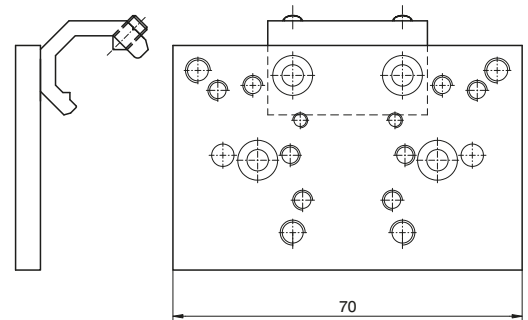

► **Bases for ISO solenoid valves**

Ordering code

1320.21	bases for ISO 1 solenoid valves
1320.22	bases for ISO 2 solenoid valves

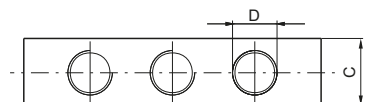
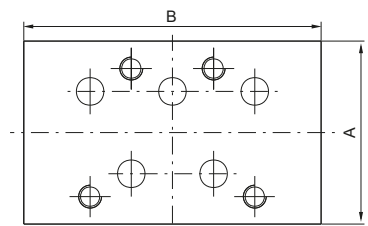

		Dimensions			
		A	B	C	D
1320.21	bases for ISO 1 solenoid valves	40	75	15	G 1/8"
1320.22	bases for ISO 2 solenoid valves	50	95	20	G 1/4"



## Series 1386-1387-1388/ 1396/1397/1398, ECOPLUS

### General

Profiled tube has two "T" slots on the three sides hosting sensors 1580. \_, MRS. \_, MHS. \_ without adaptors.

### Construction characteristics

End caps	Series 1386 - 1388: high resistant thermoplastic material	Series 1396 - 1398: Die-casting aluminium
Rod	C43 chromed steel or stainless steel	
Barrel	anodised aluminium alloy	
Rod-guide bushing	self-lubricating sintered bronze	
Piston	acetal resin, aluminium on request	
Seal	standard: NBR Oil resistant rubber, PUR Piston rod seals (PUR seals available upon request)	
Cushion adjusting screws	brass	

### Operational characteristics

Fluid	Filtered air. No lubrication needed, if applied it shall be continuous.
Max. pressure	10 bar
Operating temperature	-5°C - +70°C with standard seals -30°C - +80°C with PUR seals
Bore	Ø 32 - 40 - 50 - 63 - 80 - 100
Cushioning length	mm 27 - 31 - 31 - 37 - 40 - 44
Cushioning length "K" and "PK" version	mm 20 - 20 - 22 - 22 - 32 - 32

Please follow the suggestions below to ensure a long life for these cylinders:

- use clean and lubricated air
- correct alignment during assembly with regard to the applied load so as to avoid radial components or bending the rod;
- avoid high speeds together with long strokes and heavy loads: this would produce kinetic energy which the cylinder cannot absorb, especially if used as a limit stop (in this case use mechanical stop device and aluminium piston);
- evaluate the environmental characteristics of cylinder used (high temperature, hard atmosphere, dust, humidity etc.)

**Please note: air must be dried for applications with lower temperature.**

Use hydraulic oils H class (ISO VG32) for correct continued lubrication.

Our Technical Department will be glad to help.

#### Standard strokes (for all diameters)

from 0 to 150, every 25 mm
from 150 to 500, every 50 mm
from 500 to 1000, every 100

On request are available strokes up to 2800 mm

#### Stroke tolerance (ISO 15552)

Bore	Stroke	Tolerance
32 - 40 - 50	up to 500	+2 0
	over 500 up to 1000	+3.2 0
63 - 80 - 100	up to 500	+2.5 0
	over 500 up to 1000	+4 0

Basic version "01"

Ordering code
<b>TECHNOPOLYMER COVERS</b>
1386.Ø.stroke.01 Magnetic chromed rod
1387.Ø.stroke.01 Magnetic stainless steel rod
1388.Ø.stroke.01 Non magnetic chromed rod
<b>ALUMINIUM COVERS</b>
1396.Ø.stroke.01 Magnetic chromed rod
1397.Ø.stroke.01 Magnetic stainless steel rod
1398.Ø.stroke.01 Non magnetic chromed rod

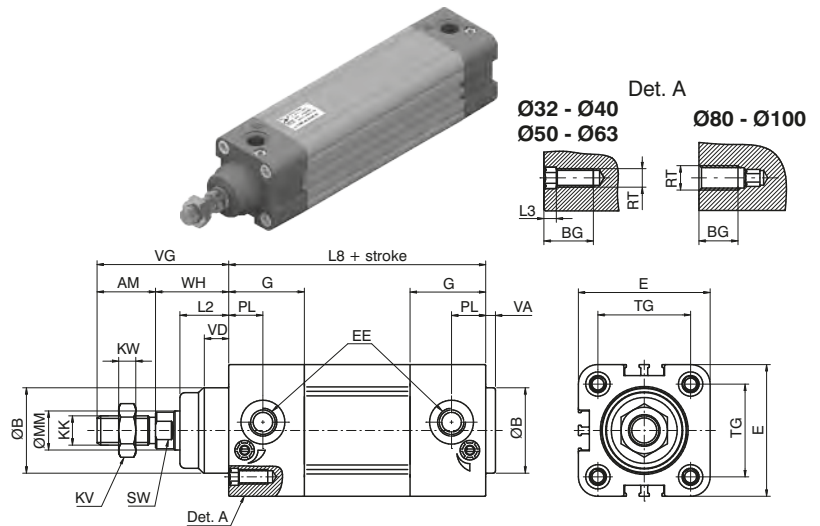

Through rod cylinder version "02"

Ordering code
<b>TECHNOPOLYMER COVERS</b>
1386.Ø.stroke.02 Magnetic chromed rod
1387.Ø.stroke.02 Magnetic stainless steel rod
1388.Ø.stroke.02 Non magnetic chromed rod
<b>ALUMINIUM COVERS</b>
1396.Ø.stroke.02 Magnetic chromed rod
1397.Ø.stroke.02 Magnetic stainless steel rod
1398.Ø.stroke.02 Non magnetic chromed rod

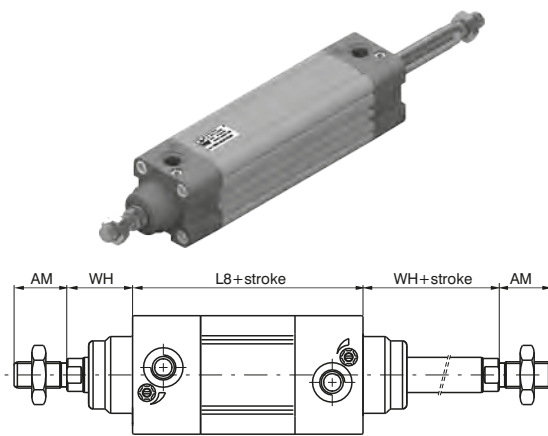

Tandem push with common rods "G"

Ordering code
<b>TECHNOPOLYMER COVERS</b>
1386.Ø.stroke.G Magnetic chromed rod
1387.Ø.stroke.G Magnetic stainless steel rod
1388.Ø.stroke.G Non magnetic chromed rod
<b>ALUMINIUM COVERS</b>
1396.Ø.stroke.G Magnetic chromed rod
1397.Ø.stroke.G Magnetic stainless steel rod
1398.Ø.stroke.G Non magnetic chromed rod

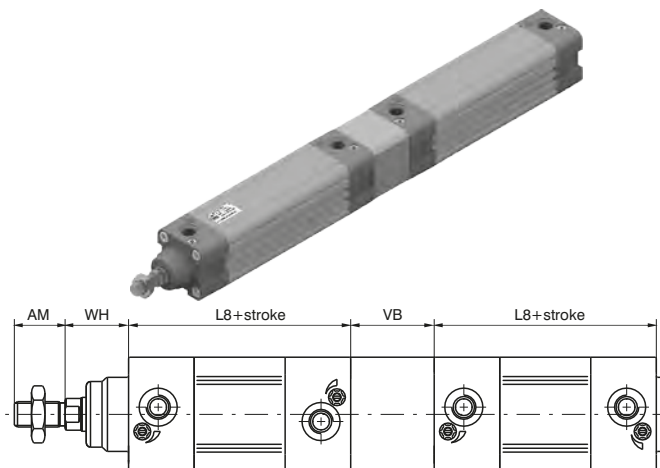

Tandem push with independent rods "F"

Ordering code
<b>TECHNOPOLYMER COVERS</b>
1386.Ø.stroke.stroke1.F Magnetic chromed rod
1387.Ø.stroke.stroke1.F Magnetic stainless steel rod
1388.Ø.stroke.stroke1.F Non magnetic chromed rod
<b>ALUMINIUM COVERS</b>
1396.Ø.stroke.stroke1.F Magnetic chromed rod
1397.Ø.stroke.stroke1.F Magnetic stainless steel rod
1398.Ø.stroke.stroke1.F Non magnetic chromed rod

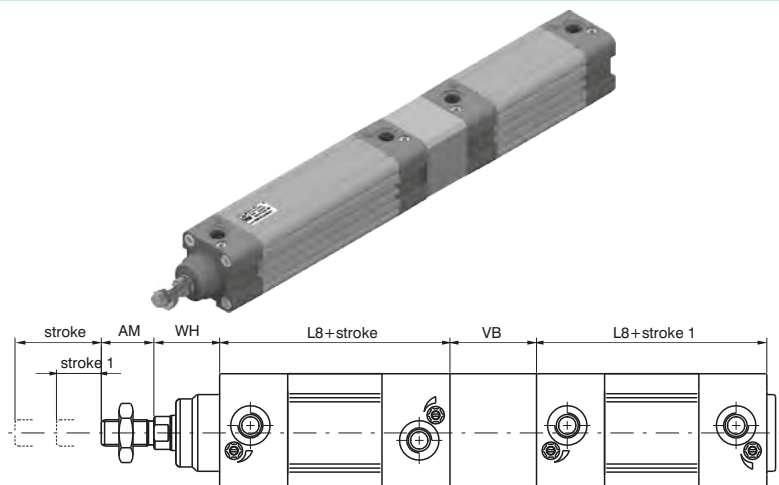

**Opposed tandem with common rod "D"**

Ordering code

**TECHNOPOLYMER COVERS**

- 1386.Ø.stroke.stroke1.D Magnetic chromed rod
- 1387.Ø.stroke.stroke1.D Magnetic stainless steel rod
- 1388.Ø.stroke.stroke1.D Non magnetic chromed rod

**ALUMINIUM COVERS**

- 1396.Ø.stroke.stroke1.D Magnetic chromed rod
- 1397.Ø.stroke.stroke1.D Magnetic stainless steel rod
- 1398.Ø.stroke.stroke1.D Non magnetic chromed rod

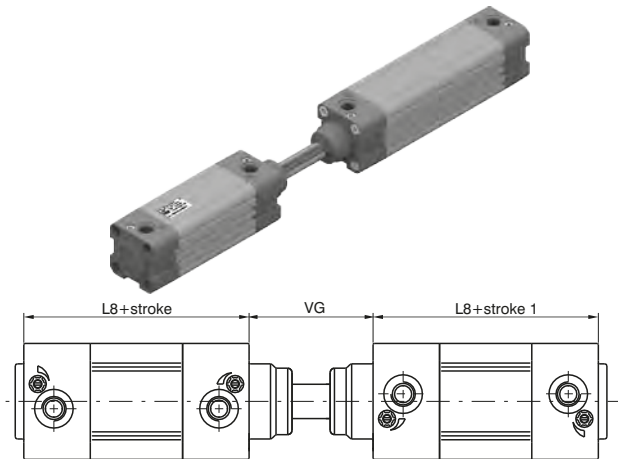

**Tandem with opposed rods "E"**

Ordering code

**TECHNOPOLYMER COVERS**

- 1386.Ø.stroke.stroke1.E Magnetic chromed rod
- 1387.Ø.stroke.stroke1.E Magnetic stainless steel rod
- 1388.Ø.stroke.stroke1.E Non magnetic chromed rod

**ALUMINIUM COVERS**

- 1396.Ø.stroke.stroke1.E Magnetic chromed rod
- 1397.Ø.stroke.stroke1.E Magnetic stainless steel rod
- 1398.Ø.stroke.stroke1.E Non magnetic chromed rod

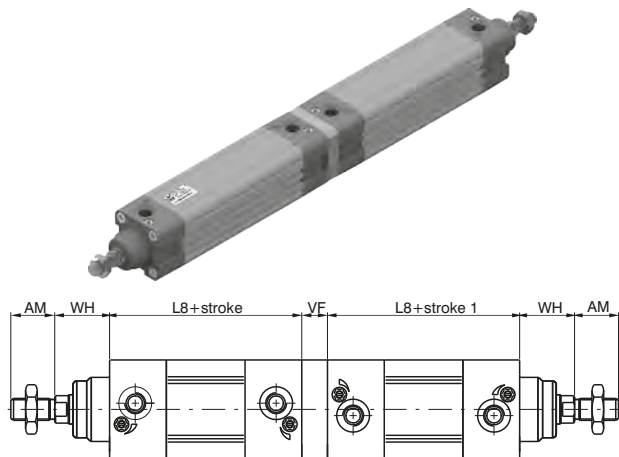

**Variants**

Ordering code

- 13\_ \_Ø.stroke.\_ \_P = Version with PUR seals
- 13\_ \_Ø.stroke.\_ \_K = Version with aluminium piston
- 13\_ \_Ø.stroke.\_ \_PK = Version with PUR seals and aluminium piston

**Table of dimensions**

Bore			32	40	50	63	80	100
AM			22	24	32	32	40	40
B (d 11)			30	35	40	45	45	55
BG			16	16	18	18	16	16
E			46	54	65	77,5	95,5	115,5
EE			G 1/8"	G 1/4"	G 1/4"	G 3/8"	G 3/8"	G 1/2"
G			29	31	33	36	40	44
KK			M10X1,25	M12X1,25	M16x1,5	M16x1,5	M20x1,5	M20x1,5
KV			17	19	24	24	30	30
KW			6	7	8	8	9	9
L2			16	20	25	25	32	35
L3			4	4	5	5	/	/
L8			94	105	106	121	128	138
MM			12	16	20	20	25	25
PL			13	14	14	16	16	18
RT			M6	M6	M8	M8	M10	M10
SW			10	13	17	17	22	22
TG			32,5	38	46,5	56,5	72	89
VA			4	4	4	4	4	4
VB			33	41	51	51	65	71
VD			8	10	12	12	15	16
VF			12	12	16	16	20	20
VG			48	54	69	69	86	91
WH			26	30	37	37	46	51
Weight	Aluminium covers	stroke 0	550	690	1200	1590	2500	3670
g		every 10 mm	29	40	57	66	96	112
Weight	Technopolymer covers	stroke 0	470	590	1020	1320	2090	3010
g		every 10 mm	29	40	57	66	96	112

### Solenoid valves supports

This accessory permits to mount a valve or an electrovalve on a side of the cylinder. The plate can be fitted on the cylinder profiled barrel, and, on it, can be mounted either a threaded distributor or a base on which can be mounted an ISO distributor. Once installed the connections must be done with fittings and pipes. All of the threaded holes on the support plate are dedicated to different valves series as per attached drawing.

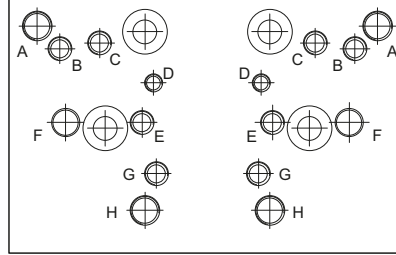

Fixing holes for valves series:

- A = 414/2
- B = 824
- C = 828, T488, 488, 484
- D = 2400
- E = 2600
- G = 858/2
- H = T424

Ordering code
<b>1386.15</b>

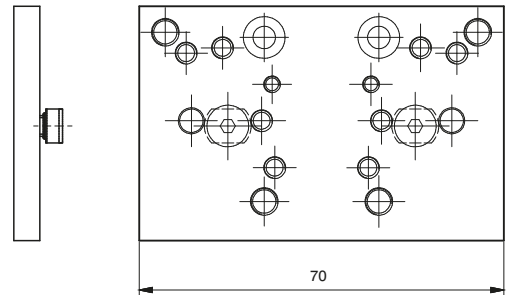

**Attention:** do not use ISO distributor for base mounting

### Bases for ISO solenoid valves

Ordering code
<b>1320.23</b> bases for ISO 1 solenoid valves
<b>1320.24</b> bases for ISO 2 solenoid valves

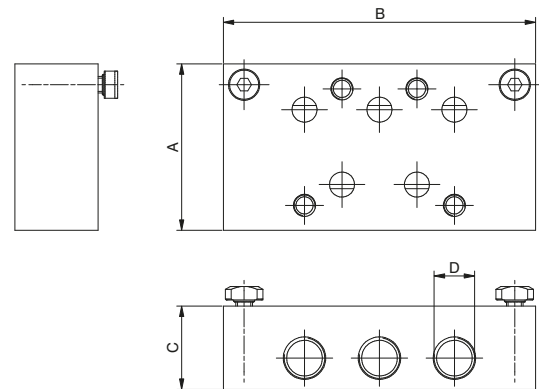

	Dimensions			
	A	B	C	D
bases for ISO 1 solenoid valves	40	75	15	G 1/8"
bases for ISO 2 solenoid valves	50	95	20	G 1/4"



## Series 1390-1391-1392, ECOLIGHT

### Construction characteristics

End caps	die-casting aluminium
Rod	C43 chromed steel or stainless steel
Barrel	aluminium alloy anodised
Rod-guide bushing	spheroid bronze on steel band with P.T.F.E. coat
Piston	Ø32 - Ø100 acetal resin, aluminium on request Ø125 - Ø200 aluminium <b>V, Q, R, L</b> versions (Ø32 - Ø100): aluminium
Seals	standard: NBR oil resistant rubber, PUR piston rod seals <b>V</b> version: FPM <b>P</b> version: PUR <b>Q</b> version: NBR and PUR with plastic rod scraper with a high wear resistance <b>R</b> version: PUR with metallic rod scraper <b>L</b> version: special PUR
Cushion adjusting screws	brass

### Operational characteristics

Fluid	Filtered air. No lubrication needed, if applied it shall be continuous. <b>L version</b> (for low temperature): dried air, guarantee a dew point lower than the minimum operating temperature
Max. pressure	10 bar
Operating temperature	-5°C - +70°C with standard seals -30°C - +80°C with PUR seals ( <b>P</b> version) -5°C - +80°C with FPM seals for 1390 and 1391 series (magnetic piston) ( <b>V</b> version) -5°C - +150°C with FPM seals for 1392 series (no magnetic piston) ( <b>V</b> version) -20°C - +80°C ( <b>Q</b> version) -10°C - +80°C ( <b>R</b> version) -50°C - +80°C ( <b>L</b> version)
Bore	Ø 32 - 40 - 50 - 63 - 80 - 100 - 125 - 160 - 200
Cushioning length	mm 27 - 31 - 31 - 37 - 40 - 44 - 44 - 50 - 55
Cushion length version with aluminum piston	mm 20 - 20 - 22 - 22 - 32 - 32 - / - / - /



Please follow the suggestions below to ensure a long life for these cylinders:

- use clean and lubricated air
- correct alignment during assembly with regard to the applied load so as to avoid radial components or bending the rod;
- avoid high speeds together with long strokes and heavy loads: this would produce kinetic energy which the cylinder cannot absorb, especially if used as a limit stop (in this case use mechanical stop device and the aluminium piston);
- evaluate the environmental characteristics of cylinder used (high temperature, hard atmosphere, dust, humidity etc.)

**VERSIONS WITH ADDITIONAL ROD SCRAPER**

**Version with plastic rod scraper (Q)**

The pneumatic seal is manufactured using a special NBR seal material, with the rod scraper that comes in contact with the external environment made of a plastic material with a high wear resistance. The geometric shape with its excellent scraping capacity guarantees additional protection of the piston rod and nose seal against the impurities, liquids, water, and debris.

**Version with metallic rod scraper (R)**

The pneumatic seal is manufactured using a special FPM seal material with its own scraping lip with the additional rod scraper that comes into contact with the external environment made of metal. This combination of scraping lip and metal rod scraper enable these actuators to be used in particularly extreme environments.

Here are some examples:

**Aluminum foundries:** To remove the residues of alumina or fluorine compounds that are deposited on the piston rod during the preparation phase of aluminum casting.

**Automotive:** To prevent debris which has collected on the piston rod damaging the nose seal during operation especially waste produced during the welding process.

**Industrial ovens:** To eliminate cement powders or those produced during the manufacture of bricks/tiles

Thanks to the high-performance nose seal and scraper protection of the piston rod, the cylinder will be protected against premature wear that you would normally experience using standard cylinders in these harsh environments.

**Low temperature version (L):** The special seals compound allows the use of the cylinders up to a temperature of -50°C. The rod scraper seal is equipped with a metallic scraper which removes ice crystals which might form at minus temperature

**Please note: air must be dry for applications with lower temperature.**

Use hydraulic oils H class (ISO VG32) for correct continued lubrication.

Our Technical Department will be glad to help.

**Standard strokes** (for all diameters)

from 0 to 150, every 25 mm
from 150 to 500, every 50 mm
from 500 to 1000, every 100 mm

On request are available strokes up to 2800 mm

**Stroke tolerance** (ISO 15552)

Bore	Stroke	Tolerance
<b>32 - 40 - 50</b>	up to 500	+2 0
	over 500 up to 1250	+3.2 0
<b>63 - 80 - 100</b>	up to 500	+2.5 0
	over 500 up to 1250	+4 0
<b>125 - 160 - 200</b>	up to 500	+4 0
	over 500 up to 1250	+5 0

**Basic version "01"**

Ordering code

- 1390.Ø.stroke.01** Magnetic chromed rod
- 1391.Ø.stroke.01** Magnetic stainless steel rod
- 1392.Ø.stroke.01** Non magnetic chromed rod

This is the configuration representing the basic cylinder according to ISO-VDMA standards. It can be directly anchored on machine parts using the four threads on the end cap screws. For other applications see "Cylinder section" on the General Catalogue, where different types of attachments are shown.

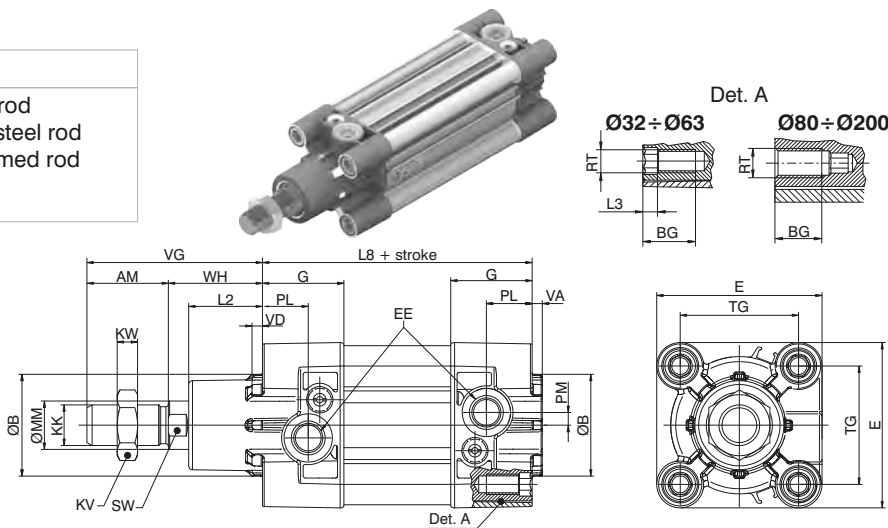

**Through rod cylinder version "02"**

Ordering code

- 1390.Ø.stroke.02** Magnetic chromed rod
- 1391.Ø.stroke.02** Magnetic stainless steel rod
- 1392.Ø.stroke.02** Non magnetic chromed rod

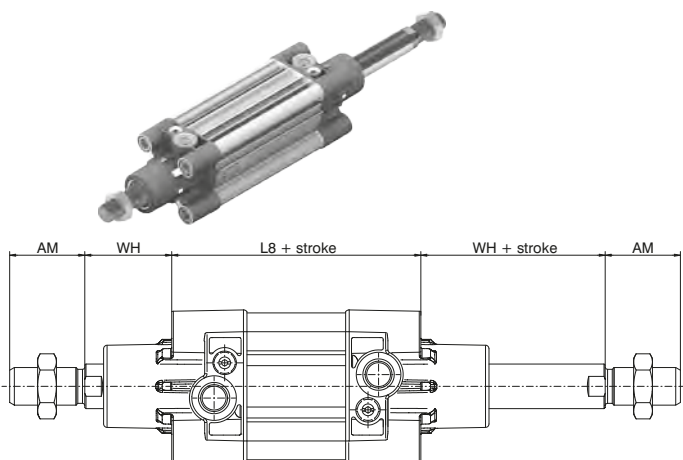

**Tandem push with common rods "G"**

Ordering code

- 1390.Ø.stroke.G** Magnetic chromed rod
- 1391.Ø.stroke.G** Magnetic stainless steel rod
- 1392.Ø.stroke.G** Non magnetic chromed rod

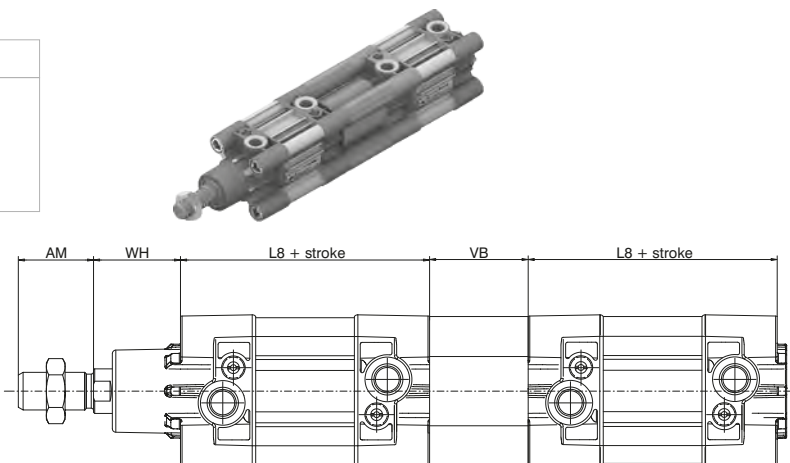

**Tandem push with independent rods "F"**

Ordering code

- 1390.Ø.stroke.stroke1.F** Magnetic chromed rod
- 1391.Ø.stroke.stroke1.F** Magnetic stainless steel rod
- 1392.Ø.stroke.stroke1.F** Non magnetic chromed rod

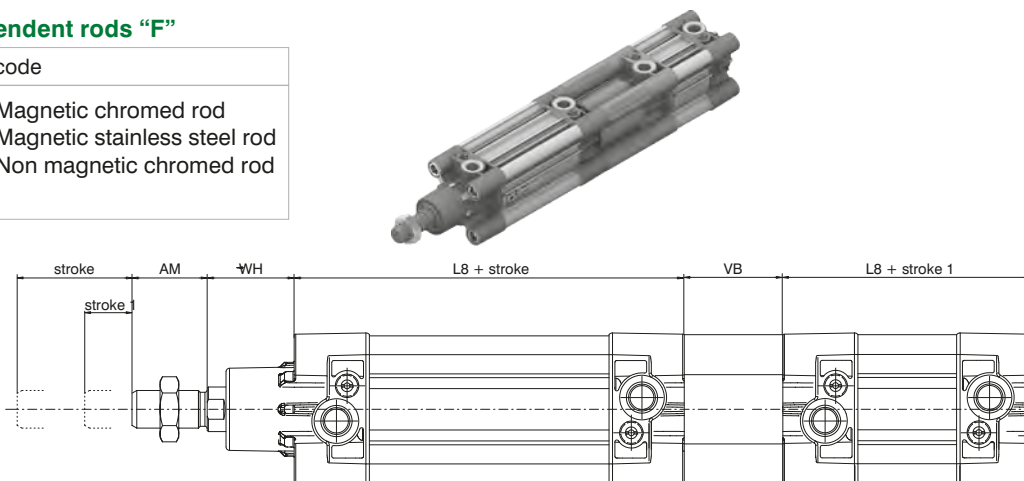

3 PNEUMATIC ACTUATION



► **Opposed tandem with common rod "D"**

Ordering code

**1390.Ø.stroke.stroke1.D** Magnetic chromed rod  
**1391.Ø.stroke.stroke1.D** Magnetic stainless steel rod  
**1392.Ø.stroke.stroke1.D** Non magnetic chromed rod

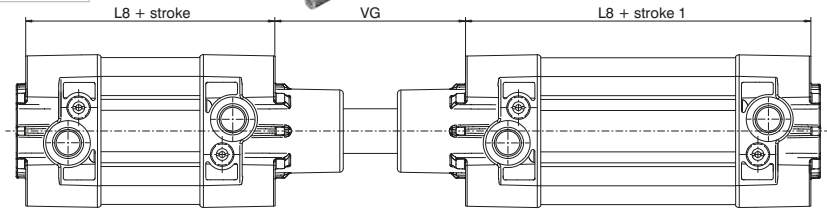
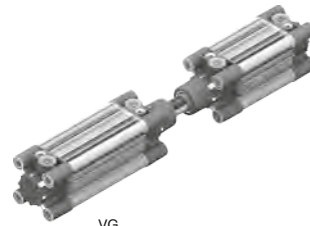

► **Tandem with opposed rods - "E"**

Ordering code

**1390.Ø.stroke.stroke1.E** Magnetic chromed rod  
**1391.Ø.stroke.stroke1.E** Magnetic stainless steel rod  
**1392.Ø.stroke.stroke1.E** Non magnetic chromed rod

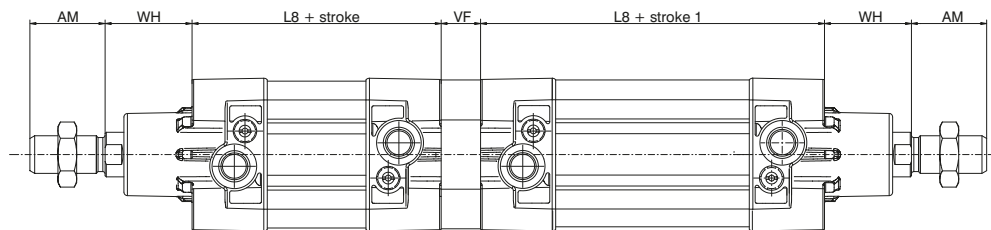

**Variants**

Ordering code

**139\_Ø.stroke.\_.P** = Version with PUR seals  
**139\_Ø.stroke.\_.K** = Version with aluminium piston (from Ø32 to Ø100)  
**139\_Ø.stroke.\_.PK** = Version with PUR seals and aluminium piston (from Ø32 to Ø100)  
**139\_Ø.stroke.\_.V** = Version with FPM seals and aluminium piston  
**139\_Ø.corsa.\_.R** = Version with metallic rod scraper and aluminium piston (Ø32-Ø100)  
**139\_Ø.corsa.\_.Q** = Version with plastic rod scraper and aluminium piston (Ø32-Ø100)  
**139\_Ø.stroke.\_.PQ** = Version with PUR seals and plastic rod scraper and aluminium piston (Ø32-Ø100)  
**139\_Ø.corsa.\_.L** = Version for low temperature and aluminium piston (-50°C) (Ø32-Ø100)

**Table of dimensions**

Bore	32	40	50	63	80	100	125	160	200	
AM	22	24	32	32	40	40	54	72	72	
B (d 11)	30	35	40	45	45	55	60	65	75	
BG	16	16	18	18	16	16	21	25	25	
E	47	54	65	76	95	113	138	180	216	
EE	G 1/8"	G 1/4"	G 1/4"	G 3/8"	G 3/8"	G 1/2"	G 1/2"	G 3/4"	G 3/4"	
G	29.5	33	32	36	38.5	41.5	48	49	49	
KK	M10X1.25	M12X1.25	M16x1.5	M16x1.5	M20x1.5	M20x1.5	M27x2	M36x2	M36x2	
KV	17	19	24	24	30	30	41	55	55	
KW	6	7	8	8	9	9	12	18	18	
L2	19	22	29	29	35	36	45	50	60	
L3	4	4	5	5	/	/	/	/	/	
L8	94	105	106	121	128	138	160	180	180	
MM	12	16	20	20	25	25	32	40	40	
PL	13	16	18	18	16	18	25	26	25	
PM	3	4	5	4.5	2.5	6	8	11	11	
RT	M6	M6	M8	M8	M10	M10	M12	M16	M16	
SW	10	13	17	17	22	22	27	36	36	
TG	32.5	38	46.5	56.5	72	89	110	140	175	
VA	4	4	4	4	4	4	6	6	6	
VB	33	41	51	51	65	71	75	70	75	
VD	4	4	4	4	4	4	6	6	6	
VF	12	12	16	16	20	20	25	30	30	
VG	48	54	69	69	86	91	119	152	167	
WH	26	30	37	37	46	51	65	80	95	
Weight	stroke 0	460	650	1030	1360	2180	2890	5700	11200	14900
	every 10 mm	23	32	45	49	75	81	130	195	245

On the ECOLIGHT series it is possible to use three sensor types, according to bore, as indicated below:

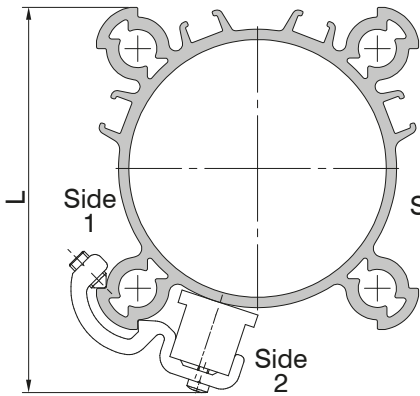

Ø32 - Ø100: the sensors can be fixed on the three sides as indicated in the drawing, by using suitable brackets (except for Ø32 on side 2)

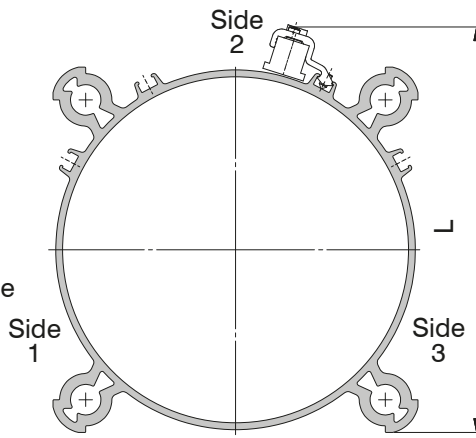

Ø125 - Ø200: the sensors can be fixed on the three sides as indicated in the drawing, by using suitable bracket

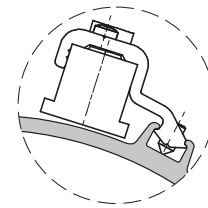

Code	Bore	L
1390.A	Ø32	58
	Ø40	65
1390.B	Ø50	75
	Ø63	86
1390.C	Ø80	105
	Ø100	122
1390.D	Ø125	150
	Ø160	190
	Ø200	225

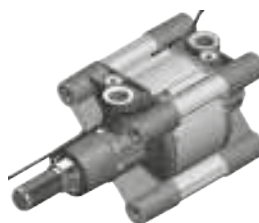
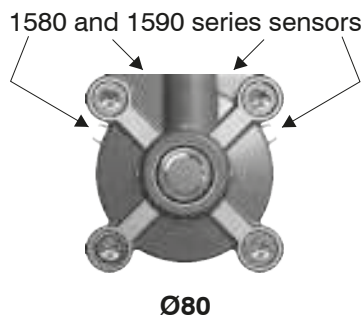
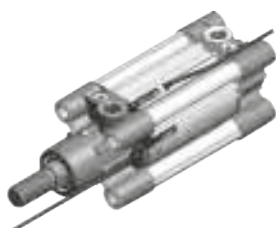
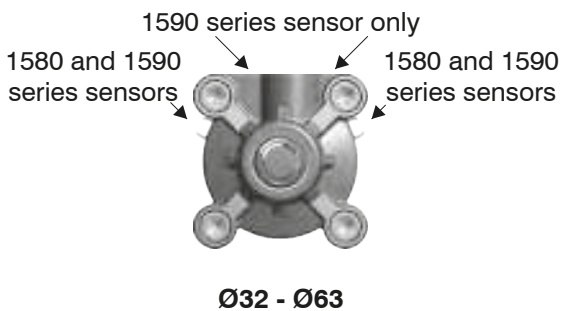
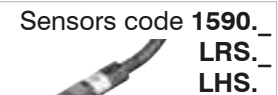
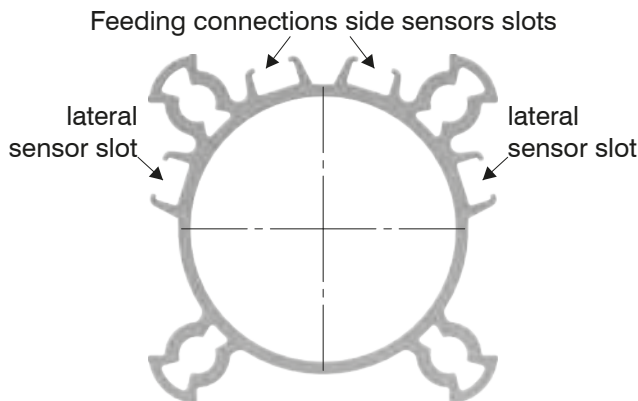
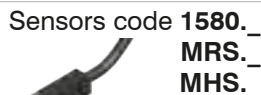

**CYLINDERS - BORE SIZE Ø80:**

The two top housing can be accessed from the front of the unit, one housing can be accessed from the front end cap and the opposite housing from the rear end cap. It is therefore possible to use both type of sensors: 1580 - 1590.

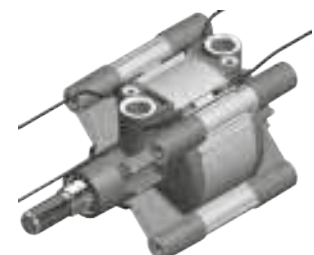
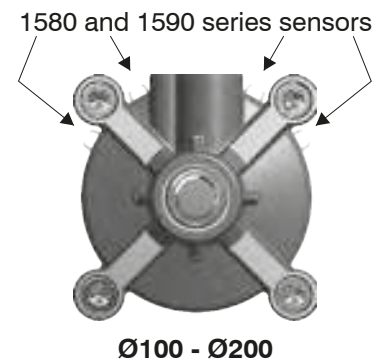

**CYLINDERS - BORE SIZE Ø100-Ø200:**  
 All four housings can be accessed from the front of the unit. It is therefore possible to use both type of sensors: 1580 - 1590.

**CYLINDERS - BORE SIZES Ø32 to Ø63:**

The two slots on connection side are plugged, therefore only sensor 1590 can be used. Suitable for top housing and once placed by means of its screw, it can be fixed in desired position.

### Solenoid valves supports

This accessory permits to mount a valve or an electrovalve on a side of the cylinder. The plate can be fitted on the cylinder profiled barrel. Once installed the connections must be done with fittings and pipes. All of the threaded holes on the support plate are dedicated to different valves series as per attached drawing.

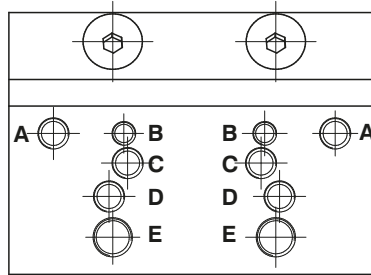

Fixing holes for valves series:

- A = 488 / 484
- B = 2400
- C = T488
- D = 2600
- E = T424

Ordering code
<b>1390.25</b> (for Ø32)
<b>1390.26</b> (for Ø40)
<b>1390.27</b> (for Ø50)
<b>1390.28</b> (for Ø63)
<b>1390.29</b> (for Ø80)
<b>1390.30</b> (for Ø100)

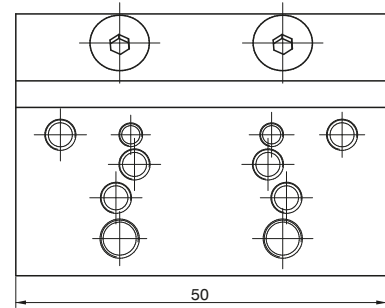
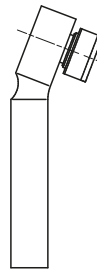

**Attention:** do not use ISO distributor for base mounting

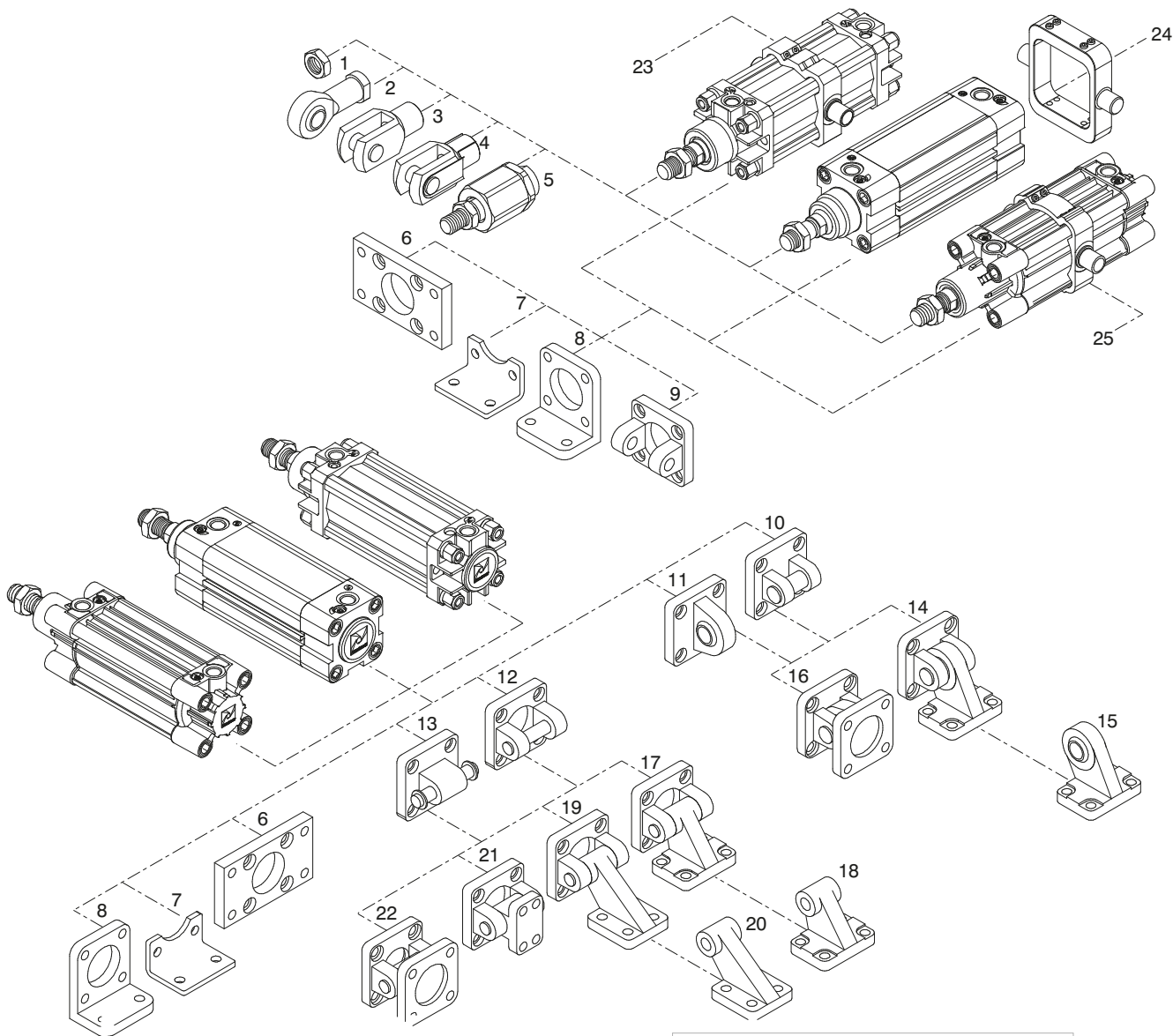

Pos.	Description	Ordering code	
		Aluminium	Steel
1	Rod nut	/	1320.Ø.18F
2	Ball joint	/	1320.Ø.32F
3	Forks	/	1320.Ø.13F
4	Fork with clips	/	1320.Ø.13/1F
5	Self-aligning joint	/	1320.Ø.33F
6	Flange (MF1-MF2)	1390.Ø.03F 1390.Ø.03FP	1380.Ø.03F
7	Short mounting foot brackets (in sheet metal MS1)	/	1320.Ø.05/1F
8	Standard mounting foot brackets	1320.Ø.05F	/
9	Front clevis	1380.Ø.08F	1320.Ø.19F
10	Rear narrow clevis (AB6)	1380.Ø.30F	1320.Ø.29F
11	Rear male clevis (with jointed head according to DIN 648K standard)	1380.Ø.15F	1320.Ø.25F
12	Rear female clevis (MP2)	1380.Ø.09F	1320.Ø.20F
13	Rear male clevis (MP4)	1380.Ø.09/1F	1320.Ø.21F
14	Complete square angle trunnion (pos.10 + pos.15)	/	1320.Ø.27F
15	Simple square counter clevis (pos.14)	/	1320.Ø.28F
16	Square angle trunnion with jointed head (pos.10 + pos.11)	1380.Ø.36F	1320.Ø.26F
17	Square angle trunnion (AB7) (pos.18 + pos.12)	1380.Ø.35F	1320.Ø.23F
18	Simple square counter clevis (pos.17)	1320.Ø.11/2F	1320.Ø.24F
19	Simple rear trunnion with support brackets (pos.20 + pos.12)	1380.Ø.11F	/
20	Simple square counter clevis (pos.19)	1320.Ø.11/1F	/
21	Standard trunnion	1380.Ø.10F	/
22	Standard complete trunnion (pos.12 + pos.13)	1380.Ø.22F	1320.Ø.22F
23	1319 - 1321 cylinders series Intermediate trunnion	1320.Ø.12BF	1320.Ø.12F
24	1386 - 1388 / 1396 - 1398 Ecoplus series Intermediate trunnion	/	1386.Ø.12F
25	1390 - 1392 Ecolight series Intermediate trunnion	1390.Ø.12F	/

► **Front and rear flanges (MF1 - Mf2)**

Ordering code		
Steel	:	<b>1380.Ø.03F</b> (Ø32 ... Ø200)
Aluminium	:	<b>1390.Ø.03F</b> (Ø32 ... Ø100)
Die-casting aluminium	:	<b>1390.Ø.03FP</b> (Ø32 ... Ø100)

Plate which allows anchorage of the cylinder at a right angle to the plane. It is made of zinc-plated extruded steel.

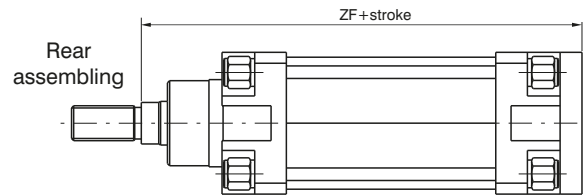
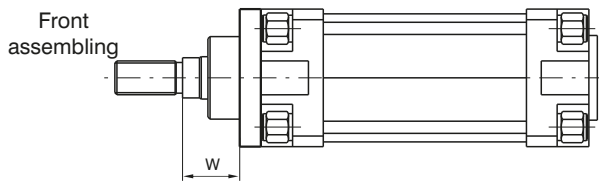
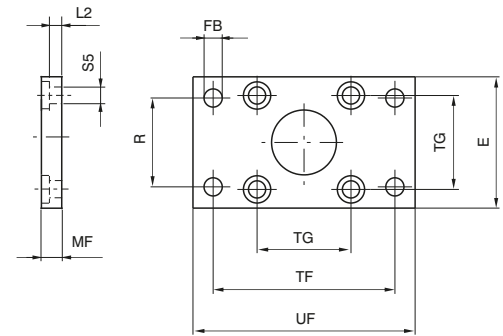

Bore	E	FB (H 13)	MF (JS 14)	R (JS 14)	TF (JS 14)	TG	UF	ZF	W	L2	S5	Weight(g) steel	Weight(g) aluminium	Weight(g) Die-casting aluminium
32	45	7	10	32	64	32,5	80	130	16	5	6,6	190	65	60
40	52	9	10	36	72	38	90	145	20	5	6,6	250	90	69
50	65	9	12	45	90	46,5	110	155	25	6,5	9	480	170	130
63	75	9	12	50	100	56,5	120	170	25	6,5	9	620	220	170
80	95	12	16	63	126	72	150	190	30	8	11	1430	500	345
100	115	14	16	75	150	89	170	205	35	8	11	1990	690	485
125	140	16	20	90	180	110	205	245	45	10,5	14	3750	/	/
160	180	18	20	115	230	140	260	280	60	9,5	18	6350	/	/
200	220	22	25	135	270	175	300	300	70	12,5	18	11350	/	/

► **Standard mounting foot brackets**

Ordering code	
Aluminium:	<b>1320.Ø.05F</b> (1 piece)

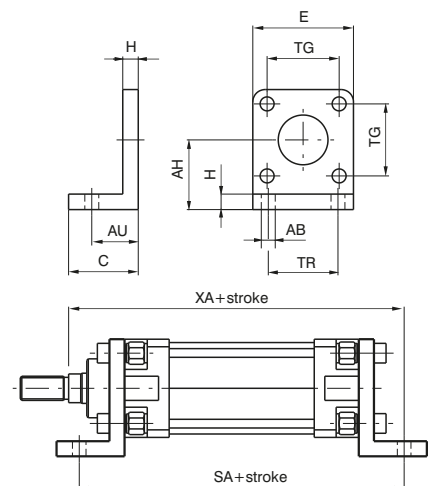

Elements used to anchor the cylinder parallel to the mounting plane. They are made of cast aluminium, painted black.

Bore	32	40	50	63	80	100	125	160	200
AB (H 14)	7	9	9	9	12	14	16	18	22
AH (JS 15)	32	36	45	50	63	71	91	115	135
AU (±0,2)	24	28	32	32	41	41	45	60	70
C	35	35	45	45	55	56	68	82	90
E	45	52	65	75	95	115	140	180	220
H	8	8	10	10	12	12	16	20	20
SA	142	161	170	185	210	220	250	300	320
TG	32,5	38	46,5	56,5	72	89	110	140	175
TR (JS 14)	32	36	45	50	63	75	90	115	135
XA	144	163	175	190	215	230	270	320	345
Weight gr.	45	65	140	175	380	470	920	2300	3200

**Short mounting foot brackets (in sheet metal MS1)**

Ordering code	
Steel:	<b>1320.Ø.05/1F</b> (1 piece)

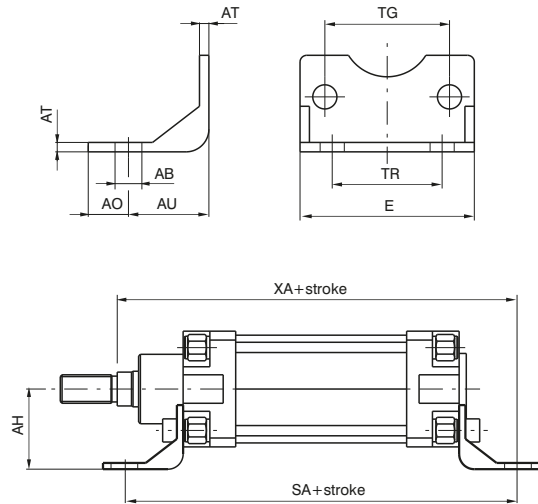

Bore	32	40	50	63	80	100	125	160	200
AB (H 14)	7	9	9	9	12	14	16	18	22
AH (JS 15)	32	36	45	50	63	71	90	115	135
AU (± 0.2)	24	28	32	32	41	41	45	60	70
AO (± 0.2)	11	8	15	13	14	16	25	15	30
E	45	52	65	75	95	115	140	180	220
AT	4	4	5	5	6	6	8	9	12
SA	142	161	170	185	210	220	250	300	320
TG	32,5	38	46,5	56,5	72	89	110	140	175
TR (JS 14)	32	36	45	50	63	75	90	115	135
XA	144	163	175	190	215	230	270	320	345
Weight g	65	80	170	190	380	452	1090	1190	3450

Elements used to anchor the cylinder parallel to the mounting plane. They are made of steel, and painted black.

**Front clevis (not specified by ISO-VDMA standards)**

Ordering code	
Aluminium:	<b>1380.Ø.08F</b>
Steel:	<b>1320.Ø.19F</b>

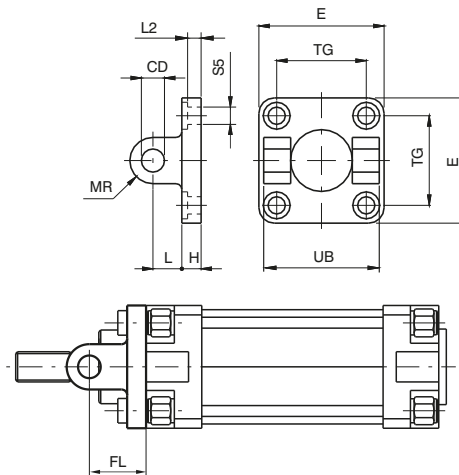

Bore	32	40	50	63	80	100	125	160	200	
CD (H9)	10	12	12	16	16	20	25	30	30	
E	Aluminium	45	52	65	75	95	115	140	180	220
	Steel	45	55	65	75	95	115	140	180	220
FL (±0,2)	22	25	27	32	36	41	50	55	60	
H	Aluminium	9	9	11	11	14	14	20	20	25
	Steel	10	10	10	12	14	16	20	20	20
L	Aluminium	13	16	16	21	22	27	30	35	35
	Steel	12	15	17	20	22	25	30	35	40
MR	10	12	12	16	16	20	25	25	25	
TG	32,5	38	46,5	56,5	72	89	110	140	175	
UB (h14)	45	52	60	70	90	110	130	170	170	
L2(±0,5)	5,5	5,5	6,5	6,5	10	10	10	10	11	
S5 (H13)	6,6	6,6	9	9	11	11	14	18	18	
Weight g	Aluminium	50	75	125	190	380	620	1180	1780	2900
	Steel	150	235	340	550	1010	1710	3360	5750	8960

Used to mount the cylinder either parallel or at a right angle to the mounting plane; allows the cylinder to self-align under load. Made of aluminium alloy or steel (see ordering code) and painted black.

**Rear clevis (MP2)**

Ordering code  
Aluminium: **1380.Ø.09F**  
Steel: **1320.Ø.20F**



Similar to type 08 but includes a hinge pin. This type of mounting allows anchorage of the cylinder either parallel or right angle to plane; the cylinder rod can oscillate and self-align as necessary when under load. Made of aluminium alloy or steel (see ordering code) and painted black.

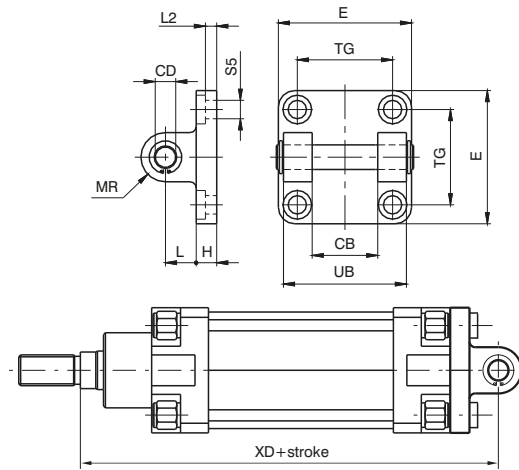

Bore		32	40	50	63	80	100	125	160	200
CB (H 14)		26	28	32	40	50	60	70	90	90
CD		10	12	12	16	16	20	25	30	30
E	Aluminium	45	52	65	75	95	115	140	180	220
	Steel	45	55	65	75	95	115	140	180	220
H	Aluminium	9	9	11	11	14	14	20	20	25
	Steel	10	10	10	12	14	16	20	20	20
L	Aluminium	13	16	16	21	22	27	30	35	35
	Steel	12	15	17	20	22	25	30	35	40
MR		10	12	12	16	16	20	25	25	25
TG		32,5	38	46,5	56,5	72	89	110	140	175
UB (h14)		45	52	60	70	90	110	130	170	170
XD		142	160	170	190	210	230	275	315	335
L2(±0,5)		5,5	5,5	6,5	6,5	10	10	10	10	11
S5		6,6	6,6	9	9	11	11	14	18	18
Weight	Aluminium	80	130	185	310	530	910	1710	2760	3820
	Steel	180	290	400	670	1160	2000	3890	6730	9880

**Rear male clevis (MP4)**

Ordering code  
Aluminium: **1380.Ø.09/1F**  
Steel: **1320.Ø.21F**



Similar to 09 clevis except for the connection, which is male rather than female. Used to mount the cylinder either parallel or at a right angle to the plane; the cylinder rod can oscillate and self-align as necessary when under load. Made of aluminium alloy or steel (see ordering code) and painted black.

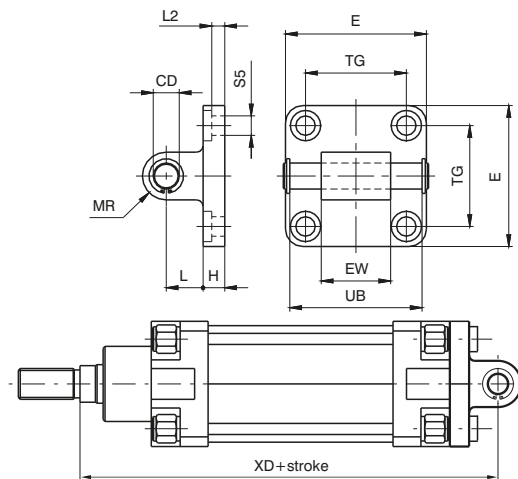

Bore		32	40	50	63	80	100	125	160	200
CD		10	12	12	16	16	20	25	30	30
E	Aluminium	45	52	65	75	95	115	140	180	220
	Steel	45	55	65	75	95	115	140	180	220
EW		26 <sup>(-0,2/-0,6)</sup>	28 <sup>(-0,2/-0,6)</sup>	32 <sup>(-0,2/-0,6)</sup>	40 <sup>(-0,2/-0,6)</sup>	50 <sup>(-0,2/-0,6)</sup>	60 <sup>(-0,2/-0,6)</sup>	70 <sup>(-0,5/-1,2)</sup>	90 <sup>(-0,5/-1,2)</sup>	90 <sup>(-0,5/-1,2)</sup>
	Aluminium	9	9	11	11	14	14	20	20	25
H	Aluminium	9	9	11	11	14	14	20	20	25
	Steel	10	10	10	12	14	16	20	20	20
L	Aluminium	13	16	16	21	22	27	30	35	35
	Steel	12	15	17	20	22	25	30	35	40
MR		10	12	12	16	16	20	25	25	25
TG		32,5	38	46,5	56,5	72	89	110	140	175
UB (h14)		46	53	61	71	91	111	132	171,5	171,5
XD		142	160	170	190	210	230	275	315	335
L2 (±0.5)		5,5	5,5	6,5	6,5	10	10	10	10	11
S5		6,6	6,6	9	9	11	11	14	18	18
Weight	Aluminium	90	130	190	340	580	960	1890	2830	3940
	Steel	210	330	430	810	1350	2400	4300	6880	8560

**Simple rear trunnion with support brackets (not specified by ISO-VDMA standards)**

Ordering code

Aluminium: **1380.Ø.11F**  
 Counter clevis can be ordered separately with code 1320.Ø.11/1F

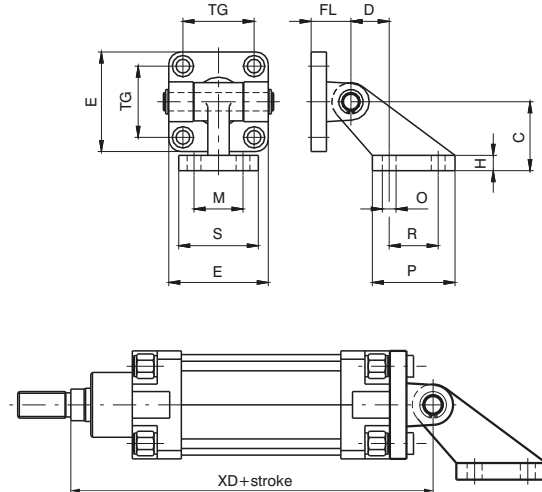

Bore	32	40	50	63	80	100	125	160	200
C (±0,2)	32	45	45	63	63	90	90	140	140
D (±0,5)	18	25	25	32	32	40	40	50	50
E	45	52	65	75	95	115	140	180	220
H	8	10	10	12	12	17	17	20	20
FL	22	25	27	32	36	41	50	55	60
M (JS 14)	25	32	32	40	40	50	50	63	63
TG	32,5	38	46,5	56,5	72	89	110	140	175
O (H 13)	7	9	9	11	11	14	14	18	18
P	37	54	54	75	75	103	103	154	154
R (JS 14)	20	32	32	50	50	70	70	110	110
S	41	52	52	63	63	80	80	110	110
XD	142	160	170	190	210	230	275	315	335
Weight g	130	260	330	600	820	1560	2530	4735	5795

Used to mount cylinders parallel to the plane to which the counter clevis is attached. Allows self-alignment of the cylinder rod under load with an oscillation up to 90 degrees from the mounting plane.

**Square angle trunnion**

Ordering code

Aluminium: **1380.Ø.35F**  
 Counter clevis can be ordered separately with code 1320.Ø.11/2F

Steel: **1320.Ø.23F (Ø32-Ø100)**  
 Counter clevis can be ordered separately with code 1320.Ø.24F

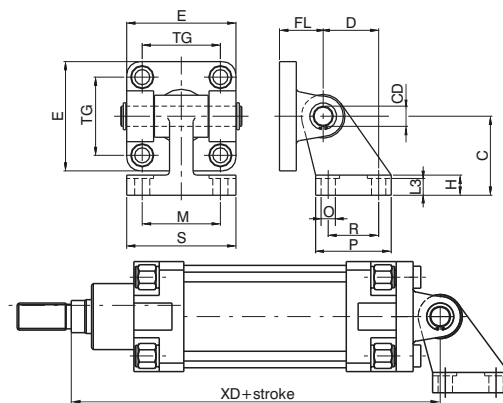

Bore		32	40	50	63	80	100	125	160	200
E	Aluminium	45	52	65	75	95	115	140	180	220
	Steel	45	55	65	75	95	115	140	180	220
TG		32,5	38	46,5	56,5	72	89	110	140	175
FL		22	25	27	32	36	41	50	55	60
D (JS14)		21	24	33	37	47	55	70	97	105
CD		10	12	12	16	16	20	25	30	30
C (JS15)		32	36	45	50	63	71	90	115	135
H	Aluminium	8	10	12	14	14	17	20	25	30
	Steel	8	10	12	12	14	15	/	/	/
L3	Aluminium	6,4	8,4	10,4	12,4	11,5	14,5	16,8	21	26
	Steel	6,5	8,5	10,5	10,5	11,5	12,5	/	/	/
R (JS14)		18	22	30	35	40	50	60	88	90
P		31	35	45	50	60	70	90	126	130
O (H13)		6,6	6,6	9	9	11	11	14	14	18
S		51	54	65	67	86	96	124	156	162
M (JS14)		38	41	50	52	66	76	94	118	122
XD		142	160	170	190	210	230	275	315	335
Weight g	Aluminium	120	180	225	435	730	1220	2325	3780	4950
	Steel	340	500	640	1250	2100	3500	/	/	/

3 PNEUMATIC ACTUATION



► **Standard trunnion (not specified by ISO-VDMA standards)**

Ordering code
Aluminium: <b>1380.Ø.10F</b>



Mounting consists of clevis 09 and counter clevis. Used to mount cylinders at a right angle to the plane to which the counter clevis is attached. Allows self-alignment of the cylinder rod under load with an oscillation of  $\pm 60$  degrees.

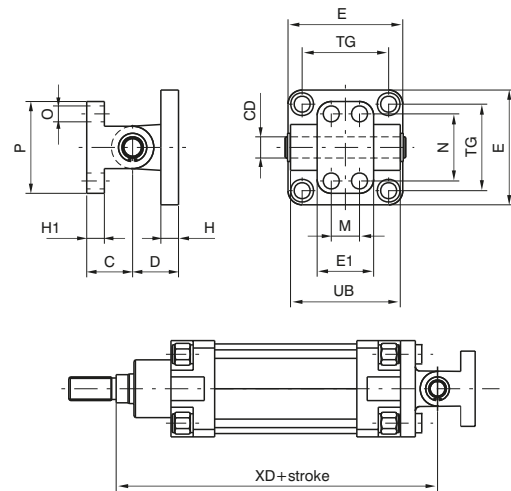

Bore	32	40	50	63	80	100	125	160	200
C ( $\pm 0.2$ )	18	26	26	34	34	41	41	55	55
CD	10	12	12	16	16	20	25	30	30
D	22	25	27	32	36	41	50	55	60
E	45	52	65	75	95	115	140	180	220
E1	25	32	32	46	46	56	56	71	71
H	10	10	12	12	16	16	20	20	25
H1	8	10	10	12	12	16	16	20	20
M ( $\pm 0.2$ )	-	16	16	25	25	32	32	43	43
N ( $\pm 0.2$ )	28	38	38	54	54	90	90	150	150
O	7	9	9	11	11	14	14	18	18
P	40	52	52	75	75	115	115	180	180
TG	32.5	38	46.5	56.5	72	89	110	140	175
UB	45	52	60	70	90	110	130	170	170
XD	142	160	170	190	210	230	275	315	335
Weight g	110	190	240	490	710	1290	2090	3690	4810

► **Rear narrow clevis**

Ordering code
Aluminium: <b>1380.Ø.30F</b>
Steel: <b>1320.Ø.29F</b> ( $\varnothing 32 \dots \varnothing 125$ )



Utilised with clevis 15F allows the cylinder to oscillate in all directions. Made of aluminium alloy or steel (see ordering code) and painted black.

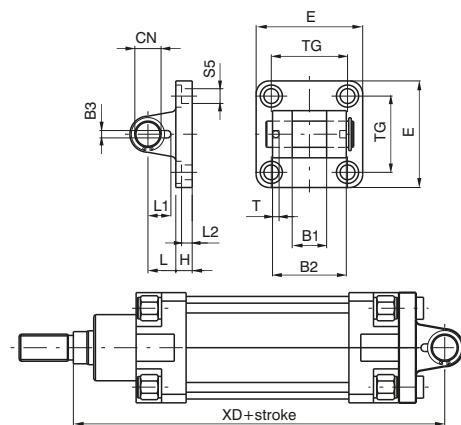

Bore	32	40	50	63	80	100	125	160	200
B1 (H 14)	14	16	21	21	25	25	37	43	43
B2 (d 12)	34	40	45	51	65	75	97	122	122
B3 ( $^{+0.2}$ )	3,3	4,3	4,3	4,3	4,3	6,3	6,3	6,3	6,3
CN	10	12	16	16	20	20	30	35	35
E	Aluminium	45	52	65	75	95	115	140	220
	Steel	45	55	65	75	95	115	140	220
H	Aluminium	9	9	11	11	14	14	20	25
	Steel	10	10	10	12	14	16	/	/
L	Aluminium	13	16	16	21	22	27	30	35
	Steel	12	15	17	20	22	25	/	/
L1	11,5	12	14	14	16	16	24	26,5	26,5
L2 ( $\pm 0,5$ )	5,5	5,5	6,5	6,5	10	10	10	10	11
S5	6,6	6,6	9	9	11	11	14	18	18
T	3	4	4	4	4	4	6	6	6
TG	32,5	38	46,5	56,5	72	89	110	140	175
XD	142	160	170	190	210	230	275	315	335
Weight g	Aluminium	70	115	200	290	570	820	1710	4380
	Steel	160	270	370	670	1110	2100	4150	/

**Rear male clevis (with jointed head according to DIN 648K standard)**

Ordering code

Aluminium: **1380.Ø.15F**  
 Steel: **1320.Ø.25F** (Ø32 ... Ø125)

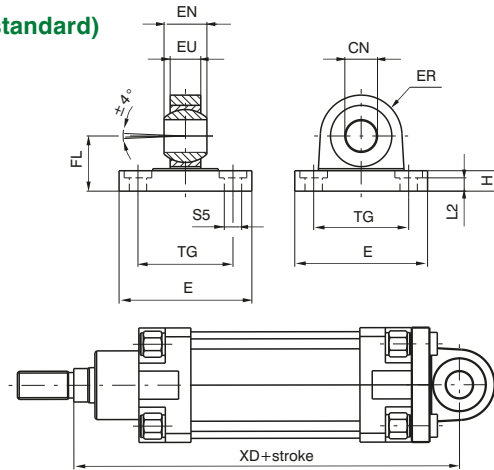
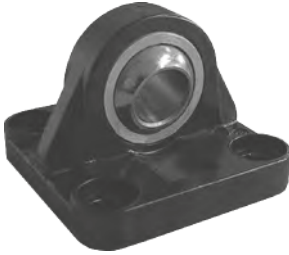

Bore		32	40	50	63	80	100	125	160	200
CN (H 7)		10	12	16	16	20	20	30	35	35
E	Aluminium	45	52	65	75	95	115	140	180	220
	Steel	45	55	65	75	95	115	140	180	220
EN (-0.1)		14	16	21	21	25	25	37	43	43
ER	Aluminium	16	19	21	24	28.5	30	40	45	48
	Steel	15	18	20	23	27	30	40	/	/
EU		10.5	12	15	15	18	18	25	28	28
FL (JS 15)		22	25	27	32	36	41	50	55	60
H	Aluminium	9	9	11	11	14	14	20	20	25
	Steel	10	10	10	12	14	16	20	/	/
L2 (±0.5)		5.5	5.5	6.5	6.5	10	10	10	10	11
S5		6.6	6.6	9	9	11	11	14	18	18
TG		32.5	38	46.5	56.5	72	89	110	140	175
XD		142	160	170	190	210	230	275	315	335
Weight g	Aluminium	60	100	180	245	480	650	1410	2420	3840
	Steel	210	310	400	710	1350	2400	4000	/	/

Utilised with clevis 30F allows the cylinder to oscillate in all directions. Made of aluminium alloy or steel (see ordering code) and painted black.

**Complete standard trunnion (with jointed head according to DIN 648K standards)**

Ordering code

Aluminium: **1380.Ø.36F**  
 Counter clevis can be ordered separately with code 1380.Ø.15F  
 Steel: **1320.Ø.26F** (Ø32-Ø125)  
 Counter clevis can be ordered separately with code 1320.Ø.25F

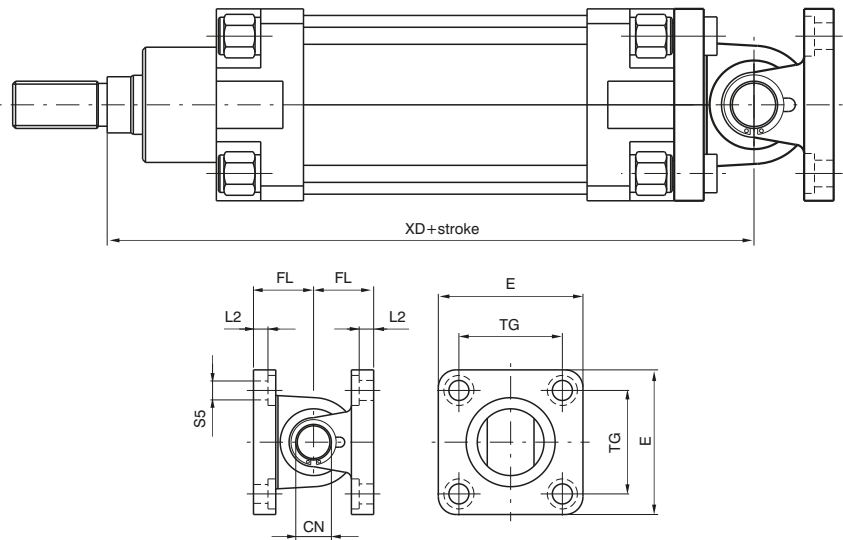

Bore		32	40	50	63	80	100	125	160	200
CN		10	12	16	16	20	20	30	35	35
E	Aluminium	45	52	65	75	95	115	140	180	220
	Steel	45	55	65	75	95	115	140	180	220
FL (JS 15)		22	25	27	32	36	41	50	55	60
L 2 (±0.5)		5.5	5.5	6.5	6.5	10	10	10	10	11
S5		6.6	6.6	9	9	11	11	14	18	18
TG		32.5	38	46.5	56.5	72	89	110	140	175
XD		142	160	170	190	210	230	275	315	335
Weight g	Aluminium	130	215	380	535	1050	1470	3120	5430	8220
	Steel	380	580	770	1380	2460	4500	8150	/	/

► **Standard complete trunnion**

Ordering code

Aluminium: **1380.Ø.22F**  
Mounting consists of rear clevis code 1380.Ø.09F  
+ rear male clevis code 1380.Ø.09/1F  
(ordering separately)

Steel: **1320.Ø.22F**  
Mounting consists of rear clevis code 1320.Ø.20F  
+ rear male clevis code 1320.Ø.21F  
(ordering separately)

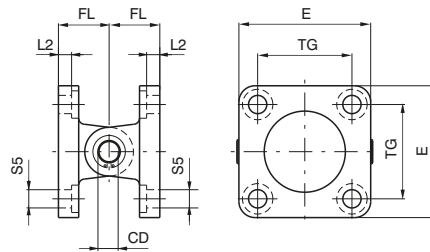
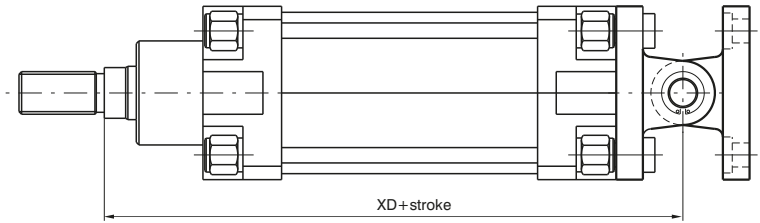

Bore	32	40	50	63	80	100	125	160	200
CD	10	12	12	16	16	20	25	30	30
E	45	55	65	75	95	115	140	180	220
FL	22	25	27	32	36	41	50	55	60
L 2 (±0.5)	5,5	5,5	6,5	6,5	10	10	10	10	11
S 5	6,6	6,6	9	9	11	11	14	18	18
TG	32,5	38	46,5	56,5	72	89	110	140	175
XD	142	160	170	190	210	230	275	315	335
Weight g	360	580	780	1370	2370	4110	7670	12650	17480

► **Complete square angle trunnion (with joined head according to DIN 648K standards)**

Ordering code

Steel: **1320.Ø.27F**  
Mounting consists of  
rear clevis narrow code 1320.Ø.29F  
+ simple counter clevis code 1320.Ø.28F  
(ordering separately)

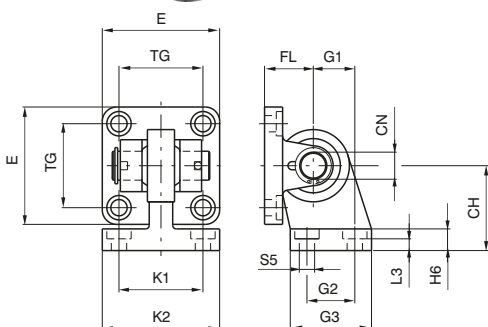
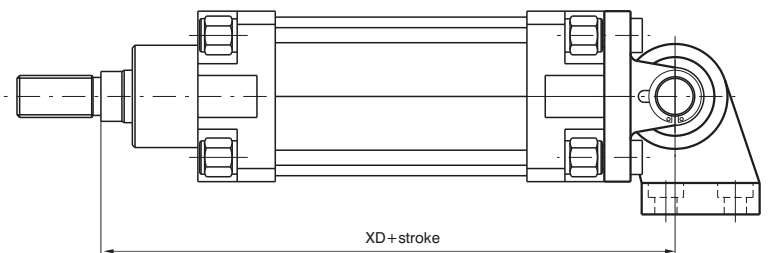

Bore	32	40	50	63	80	100	125
CH (JS 15)	32	36	45	50	63	71	90
CN	10	12	16	16	20	20	30
E	45	55	65	75	95	115	140
FL (JS 15)	22	25	27	32	36	41	50
G1 (JS 15)	21	24	33	37	47	55	70
G2 (JS 14)	18	22	30	35	40	50	60
G3	31	35	45	50	60	70	90
H6	10	10	12	12	14	15	20
K1 (JS 14)	38	41	50	52	66	76	94
K2	51	54	65	67	86	96	124
L3 (*0.5)	8,5	8,5	10,5	10,5	11,5	12,5	17
S5	6,6	6,6	9	9	11	11	14
TG	32,5	38	46,5	56,5	72	89	110
XD	142	160	170	190	210	230	275
Weight g	330	480	830	1220	2100	3580	7000

Intermediate trunnion Series 1319 - 1321

Ordering code

Steel: 1320.Ø.12F

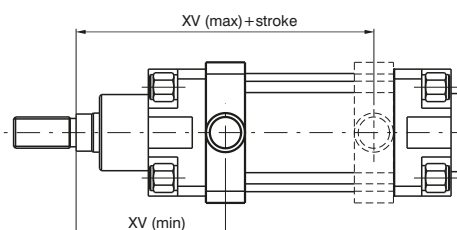
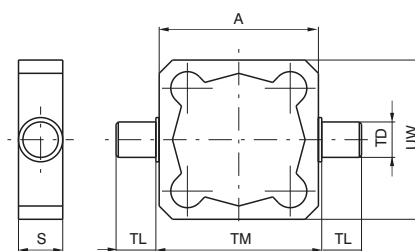
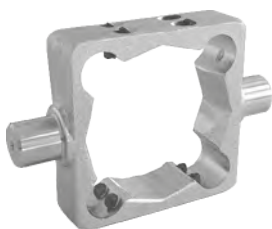

Clevis to be mounted on the barrel to have the centre of rotation of the hinge pin at a point between the end caps of the cylinder. It is attached to the barrel by means of eight pointed grains that block in the "V" groove of the four protruding shapes. In the case of anchorage subject to heavy use, it is recommended to connect the clevis once the right position has been found.

**Attention:** mounting of the clevis with contact to the end plates does not allow the use of the magnetic sensors as the switch limits.

Bore	32	40	50	63	80	100	125	160	200
A	49	62	73	87	109	130	155	190	240
S	18	21	21	27	27	32	32	40	40
TD (e9)	12	16	16	20	20	25	25	32	32
TL (h14)	12	16	16	20	20	25	25	32	32
TM (h14)	50	63	75	90	110	132	160	200	250
UW	59	62	73	87	109	130	155	190	240
XV (max.)	85	96	102	109	123.5	131.5	162	193	204
XV (min.)	61	69	78	86	96.5	108.5	128	150	168
Weight g	180	270	330	650	890	1550	1950	3580	5850

Intermediate trunnion Series 1386 - 1388 - 1396 - 1398

Ordering code

Steel: 1386.Ø.12F

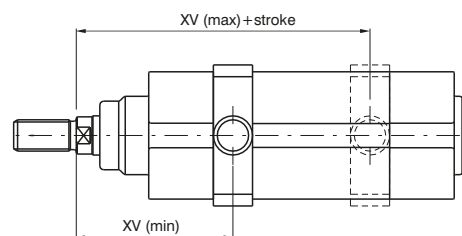
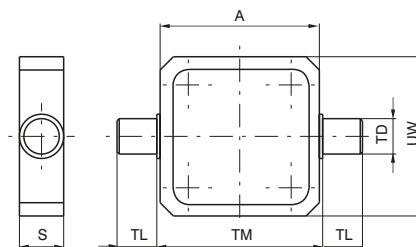
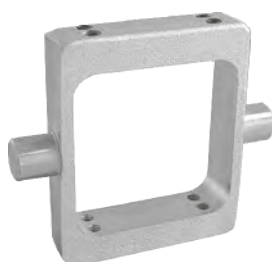

Clevis to be mounted on the barrel to have the centre of rotation of the hinge pin at a point between the end caps of the cylinder. It is attached to the barrel by means of eight pointed grains. In the case of anchorage subject to heavy use, it is recommended to connect the clevis once the right position has been found.

**Attention:** mounting of the clevis with contact to the end plates does not allow the use of the magnetic sensors as the switch limits.

Bore	32	40	50	63	80	100
A	49.8	62.6	74.1	89.1	109.1	130.1
S	18	21	21	27	27	30
TD (e 9)	12	16	16	20	20	25
TL (h 14)	12	16	16	20	20	25
TM (h 14)	50	63	75	90	110	132
UW	70	78	91	94	130	145
XV (max.)	80	91.5	97.5	106.5	118.5	127
XV (min.)	66	73.5	82.5	88.5	101.5	113
Weight g	195	350	430	565	1035	1450

► Intermediate trunnion Series 1319 - 1321

Ordering code
<b>1320.Ø.12BF</b> (Aluminium with steel bushes)



**Aluminium Intermediate Trunnion with steel bushes** to be mounted on the barrel. This solution allows the cylinder to rotate around the hinge which can be mounted in any position between the end caps. It is attached to the barrel by means of 8 grub screws which secure the Trunnion to the extruded barrel. In the case of heavy duty applications it is recommended that the Trunnion is secured using expansion pins.  
In case off applications with high speed, high load and high pressure please contact our technical office.  
**Please note:** If the Trunnion is mounted in direct contact with the cylinder end cap, it will not be possible to fit magnetic sensors at the end of stroke.

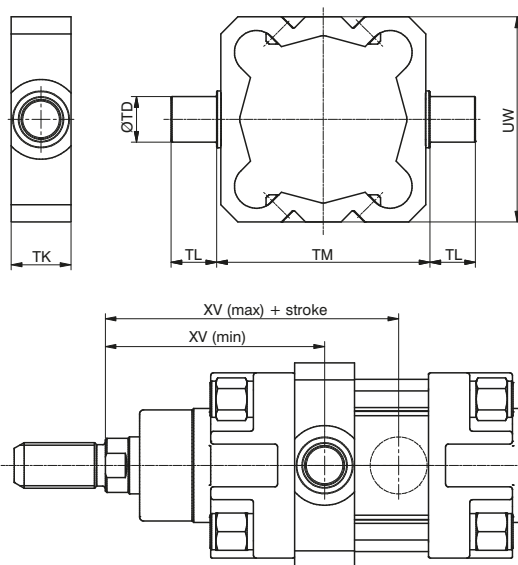

Bore	32	40	50	63	80	100
TD	Ø12	Ø16	Ø16	Ø20	Ø20	Ø25
TL	12	16	16	20	20	25
TM	50	63	75	90	110	132
TK	18	21	21	27	27	32
UW	54	60	72	87	109	130
XV min.	61	69	78	86	96.5	108.5
XV max.	85	96	102	109	123.5	131.5
Weight g	70	110	140	280	370	630

► Intermediate trunnion Series 1390 - 1392

Ordering code
<b>1390.Ø.12F</b> (Aluminium with steel bushes)



**Aluminium Intermediate Trunnion with steel bushes** to be mounted on the barrel. This solution allows the cylinder to rotate around the hinge which can be mounted in any position between the end caps. It is attached to the barrel by means of 8 grub screws which secure the Trunnion to the extruded barrel. In the case of heavy duty applications it is recommended that the Trunnion is secured using expansion pins.  
In case off applications with high speed, high load and high pressure please contact our technical office.  
**Please note:** If the Trunnion is mounted in direct contact with the cylinder end cap, it will not be possible to fit magnetic sensors at the end of stroke 1500\_., RS\_., HS\_ series.

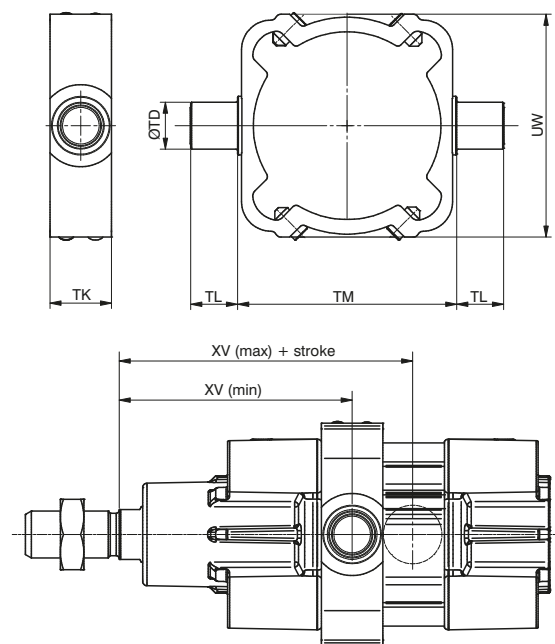

Bore	32	40	50	63	80	100
TD	Ø12	Ø16	Ø16	Ø20	Ø20	Ø25
TL	12	16	16	20	20	25
TM	53*	63	75	90	110	132
TK	18	21	21	27	27	32
UW	56	64	76	92	112	134
XV min.	65	74	80	87	99	109
XV max.	81	91	100	108	121	130.5
Weight g	60	100	125	240	320	540

\* (Ø32, TM: not according to standard ISO 15552)

Support for intermediate trunnion

Ordering code

**1320.Ø.12/1F**  
(1 piece)



Combining two supports to the intermediate trunnion it is possible to fix the cylinder on plane surface.

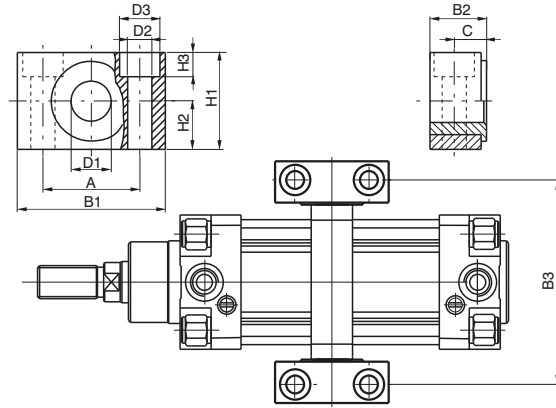

Bore	32	40	50	63	80	100	125	160	200
A (±0.2)	32	36	36	42	42	50	50	60	60
B1	46	55	55	65	65	75	75	92	92
B2	18	21	21	23	23	28.5	28.5	40	40
B3	71	87	99	116	136	164	192	245	295
C	10.5	12	12	13	13	16	16	22.5	22.5
D1 (F7)	12	16	16	20	20	25	25	32	32
D2	6.6	9	9	11	11	14	14	18	18
D3	11	15	15	18	18	20	20	26	26
H1	30	36	36	40	40	50	50	60	60
H2 (±0.1)	15	18	18	20	20	25	25	30	30
H3	7	9	9	11	11	13	13	17	17
Weight g (1 piece)	100	150	150	235	235	435	435	850	850

Rod forks and nuts

Ordering code

**1320.Ø.13F**

**1320.Ø.13/1F**  
(from ø32 to ø100)

**1320.Ø.18F**

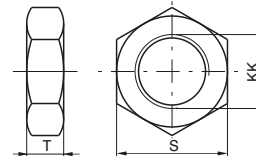
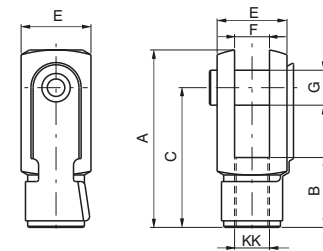
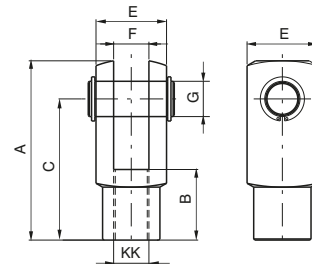

Bore	32	40	50	63	80	100	125	160	200	
A	52	62	83	83	105	105	148	188	188	
B	20	24	32	32	40	40	56	72	72	
C	40	48	64	64	80	80	110	144	144	
E	20	24	32	32	40	40	55	70	70	
F(B12)	10	12	16	16	20	20	30	35	35	
G	10	12	16	16	20	20	30	35	35	
S	17	19	24	24	30	30	41	55	55	
T	6	7	8	8	9	9	12	18	18	
KK	M10X1.25		M12X1.25	M16X1.5	M16X1.5	M20X1.5	M20X1.5	M27X2	M36X2	M36X2
Weight	forks	100	140	340	340	680	680	2500	4000	4000
g	nut	15	20	20	20	40	40	100	210	210

Fork:

Element that when screwed to the rod consents a regular functioning even when there are significant lateral forces as the connection point. Made of zinc-plated steel.

Nut:

Used to block the position of the fork.

► **Ball joint**

Ordering code
<b>1320.Ø.32F</b>

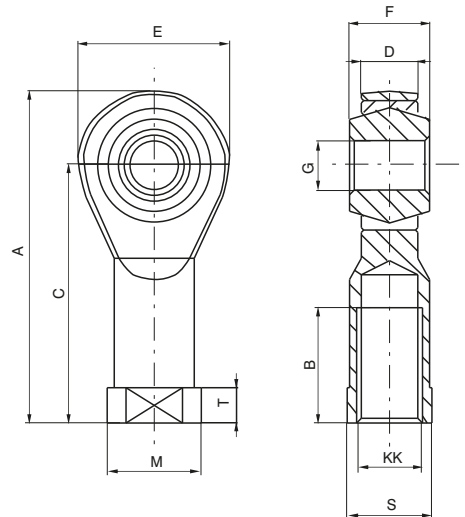

Bore	32	40	50	63	80	100	125	160	200
A	57	66	85	85	102	102	145	165	165
B	20	22	28	28	33	33	51	56	56
C	43	50	64	64	77	77	110	125	125
D (-0.1)	10.5	12	15	15	18	18	25	28	28
E	28	32	42	42	50	50	70	80	80
F	14	16	21	21	25	25	37	43	43
G (H 7)	10	12	16	16	20	20	30	35	35
KK	M10x1.25	M12x1.25	M16x1.5	M16x1.5	M20x1.5	M20x1.5	M27x2	M36x2	M36x2
M	19	22	27	27	34	34	50	58	58
S	17	19	22	22	30	30	41	50	50
T	6.5	6.5	8	8	10	10	15	17	17
Weight g	76	110	220	220	410	410	1200	1600	1600

► **Self-aligning joint**

Ordering code
<b>1320.Ø.33F</b>

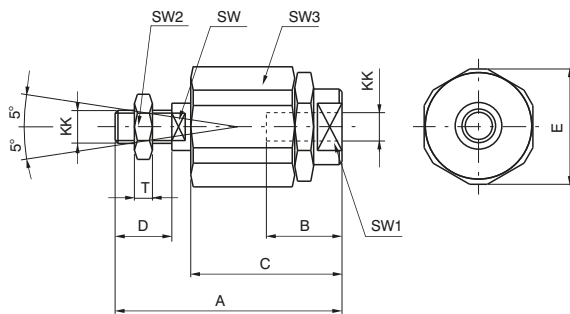

Bore	32	40	50	63	80	100
A	71	75	103	103	119	119
B	20	20	32	32	40	40
C	46	46	63	63	71	71
D	20	24	32	32	40	40
E	32	32	45	45	45	45
KK	M10x1.25	M12x1.25	M16x1.5	M16x1.5	M20x1.5	M20x1.5
SW	12	12	20	20	20	20
SW1	19	19	27	27	27	27
SW2	17	19	24	24	30	30
SW3	30	30	41	41	41	41
T	6	7	8	8	9	9
Weight g	220	230	660	660	700	700



## Series 1315, Round tube with tie rod cylinders - Ø250 / Ø320

### General

Tie rod cylinders, according to standard ISO15552.

### Construction characteristics

End caps	aluminium alloy casting
Rod	C43 chromed steel
Barrel	oxidised aluminium
Tie rod	steel with rolled threads
Cushion bushings	aluminium
Rod-guide bushing	sintered bronze
Piston	aluminium
Seals	Standard: NBR oil resistant rubber, PUR piston rod seals

### Operational characteristics

Fluid	filtered and lubricated air - hydraulic oil (with special bushing)
Pressure	max. 10 bar
Operating temperature	-5 °C - +70 °C
Cushioning length	50 mm

Please follow the suggestions below to ensure a long life for these cylinders:

- use clean and lubricated air
- correct alignment during assembly with regard to the applied load so as to avoid radial components or bending the rod.
- avoid high speeds together with long strokes and heavy loads: this would produce kinetic energy which the cylinder cannot absorb, especially if used as a limit stop (in this case use mechanical stop device);
- evaluate the environmental characteristics of cylinder used (high temperature, hard atmosphere, dust, humidity etc.)

**Please note: air must be dried for applications with lower temperature.**

Use hydraulic oils H class (ISO VG32) for correct continued lubrication.

Our Technical Department will be glad to help.



Basic version

Ordering code	
<b>1315.Ø.stroke.01A</b>	
magnetic, aluminium barrel	
<b>BORE</b>	
Ø	250 = 250 mm
	320 = 320 mm

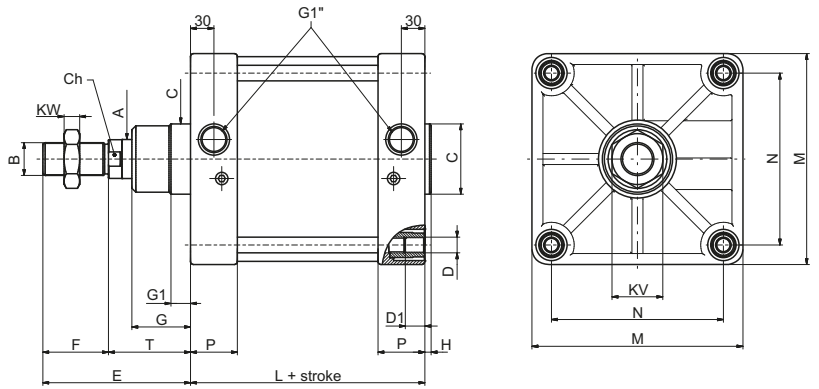

BORE	A	B	Ch	C	D	D1	E	F	G	G1	H	KW	KV	L	M	N	P	T	Weight (g)
250	Ø50	M42x2	46	Ø90	M20	25	189	84	75	25	8	21	Es64	200	270	220	60	105	28.170 (increase of 380 g each 10 mm stroke)
320	Ø63	M48x2	55	Ø110	M24	28	216	96	90	25	10	24	Es72	220	350	270	65	120	49.810 (increase of 616 g each 10 mm stroke)

Table of dimensions

Front and rear flanges

Ordering code	
<b>1315.Ø.03F</b>	
(Steel)	
<b>BORE</b>	
Ø	250 = 250 mm
	320 = 320 mm

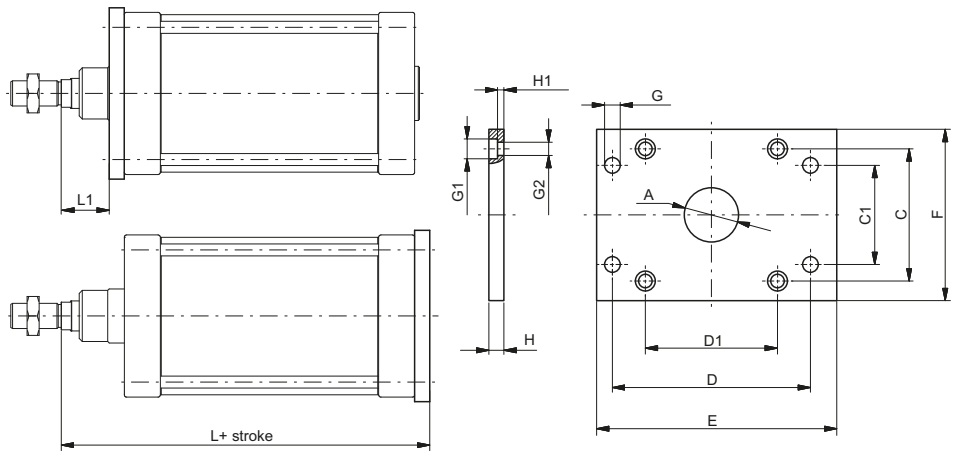

BORE	A(H11)	C	C1 (JS14)	D (JS14)	D1	E	F	G (H13)	G1 (H13)	G2 (H13)	H (±0.2)	H1 (+0, -0.5)	L	L1	Weight (g)
250	90	220	165	330	220	400	285	26	33	22	25	10,5	330	80	20.150
320	110	270	200	400	270	470	350	33	39	26	30	15	370	90	34.000

Table of dimensions

Rear clevis

Ordering code	
<b>1315.Ø.09F</b>	
<b>BORE</b>	
Ø	250 = 250 mm
	320 = 320 mm

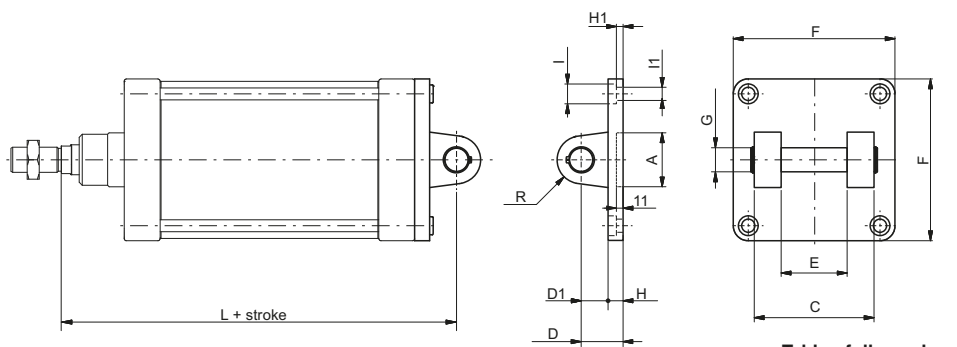

BORE	A	C (h14)	D (±0.2)	D1	E (H14)	F	G (H9)	H	H1	I	I1	L	R	Weight (g)
250	Ø90	200	70	45	110	270	40	25	11	33	22	375	40	7.800
320	Ø110	220	80	50	120	350	42,5	30	15	39	26	420	45	13.000

Table of dimensions

Rear male clevis

Ordering code	
<b>1315.Ø.09/1F</b>	
<b>BORE</b>	
Ø	250 = 250 mm
	320 = 320 mm

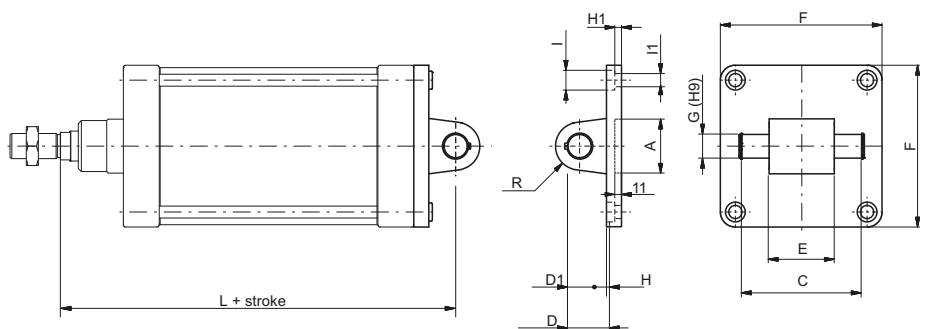

BORE	A	C (+0.3, -0)	D (±0.2)	D1	E (+0.5, -1.2)	F	G (H9)	H	H1	I	I1	L	R	Weight (g)
250	Ø90	202	70	45	110	270	40	25	11	33	22	375	40	8.300
320	Ø110	222	80	50	120	350	42,5	30	15	39	26	420	45	13.060

Table of dimensions

### Intermediate trunnion

Ordering code	
<b>1315.Ø.12F</b>	
(Steel)	
Ø	<b>Bore</b>
	250 = 250 mm
	320 = 320 mm

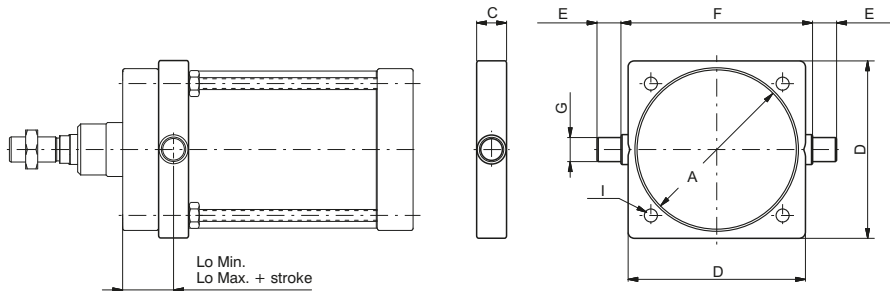
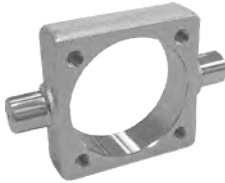

Table of dimensions

BORE	A	C	D	E (h14)	F (h14)	G (e9)	I	Lo Min.	Lo Max.	Weight (g)
250	Ø268	50	295	40	320	Ø40	Ø20,25	85	115 + stroke	10.500
320	Ø343	70	370	50	400	Ø50	Ø24,25	95	125 + stroke	25.300

### Fork with pin

Ordering code	
<b>1302.Ø.13F</b>	
(Steel)	
Ø	<b>Bore</b>
	250 = 250 mm
	320 = 320 mm

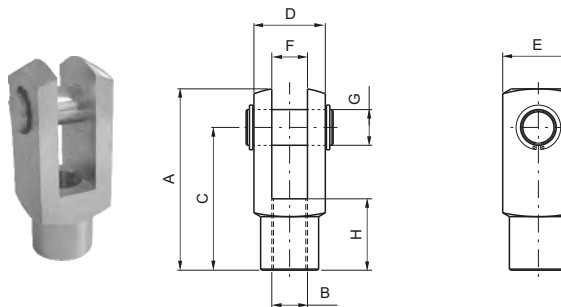

Table of dimensions

BORE	A	B	C	D	E	F	G	H	Weight (g)
250	188	M42x2 (H8)	144	70	70	35 (B12)	Ø35 (H9)	72	3.700
320	265	M48x2	192	96	96	50	Ø50	96	9.700

### Rod lock nut

Ordering code	
<b>1302.Ø.18F</b>	
(Steel)	
Ø	<b>Bore</b>
	250 = 250 mm
	320 = 320 mm

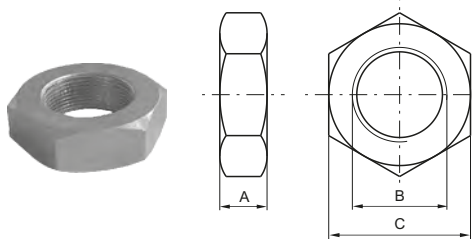

Table of dimensions

BORE	A	B	C	Weight (g)
250	21	M42x2	65	260
320	24	M48x2	72	580

### Ball joint

Ordering code	
<b>1302.Ø.32F</b>	
(Steel)	
Ø	<b>Bore</b>
	250 = 250 mm
	320 = 320 mm

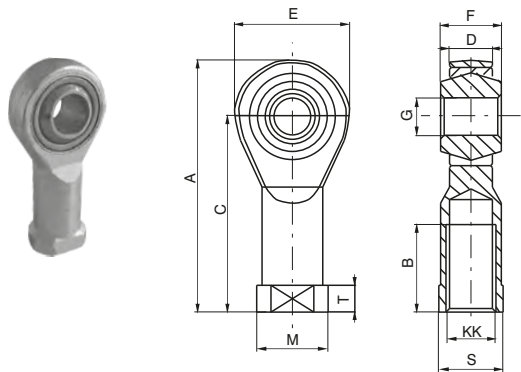

Table of dimensions

BORE	250	320
A	187	218
B	60	65
C	142	162
D (-0.1)	33	45
E	91	117
F	49	60
G (H 7)	40	50
KK	M42x2	M48x2
M	65	75
S	55	65
T	19	23
Weight g.	2.400	5.000

### Sensor bracket - codes 1500.\_,RS.\_,HS.\_

Ordering code	
<b>1306.D (Ø250)</b>	
<b>1306.E (Ø320)</b>	

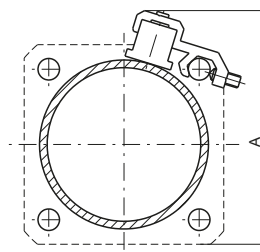

Table of dimensions

BORE	A
250	250
320	365

For technical characteristics and Sensors ordering code see "Magnetic sensors" section

3 PNEUMATIC ACTUATION



## Series AISI 316 stainless steel - Steel line

### General

The 1393-1394 stainless steel ISO 15552 cylinders series are designed for corrosion resistance application such as marine, pharmaceutical and food ambiances.

The pre lubrication grease used is NSF H1 certified for food application.

Specific care has been taken during the design stages and the result is a clean profile cylinder easy to clean and free from possible residue build-up areas.

All parts in contact with the external environment are in Stainless steel 316L and the seals are available in two different compounds for different temperature applications: PUR -30°C - +80°C and FPM -5°C - +150°C.

The range starts from 32 bore up to 100 bore, round barrel and tie rods design. Double acting version standard or with through rod, magnetic or not magnetic piston available.

The piston is aluminium and the sensor bracket, when required is in stainless steel 316.

The cylinder can be fixed via the threaded holes in the tie rod nuts or with the wide range of stainless steel accessories.

### Construction characteristics

End caps, piston rod, barrel, cushion screws	Stainless steel AISI 316
Rod-guide bushings	Stainless steel AISI 316 with P.T.F.E. coat
Half-pistons	Aluminium
Seals	PUR or FPM on request
Lubricating grease	NSF-H1 certified grease for incidental contact with food

### Operational characteristics

Fluid	Filtered air. No lubrication needed, if applied it shall be continuous.
Max. pressure	10 bar
Operating temperature	-30° C - +80°C with PUR seals -5° C - +150°C with FPM seals and non magnetic piston -5° C - +80°C with FPM seals and magnetic piston
Bore	Ø 32 - 40 - 50 - 63 - 80 - 100
Cushioning length	mm 20 - 20 - 22 - 22 - 32 - 32

Please follow the suggestions below to ensure a long life for these cylinders:

- use clean and lubricated air
- correct alignment during assembly with regard to the applied load so as to avoid radial components or bending the rod.
- avoid high speeds together with long strokes and heavy loads: this would produce kinetic energy which the cylinder cannot absorb, especially if used as a limit stop (in this case use mechanical stop device)
- evaluate the environmental characteristics of cylinder used (high temperature, hard atmosphere, dust, humidity etc.)

**Please note: air must be dried for applications with lower temperature.**

Our Technical Department will be glad to help.

### Standard strokes (for all diameters)

from 0 to 150, every 25 mm
over 150 up to 500, every 50 mm
over 500 up to 1000, every 100

### Stroke tolerance (ISO 15552)

Bore	Stroke	Tolerance
32 - 40 - 50	up to 500	+2 0
	over 500 up to 1250	+3.2 0
63 - 80 - 100	up to 500	+2.5 0
	over 500 up to 1250	+4 0

On request are available strokes up to 2800 mm

**Basic version "01"**

Ordering code

**1393.Ø.stroke.01** Magnetic  
**1394.Ø.stroke.01** Non magnetic

This is the configuration representing the basic cylinder according to ISO standards. It can be directly anchored on machine parts using the four threads on the end cap screws. For other applications see the pages about different types of stainless steel fixings.

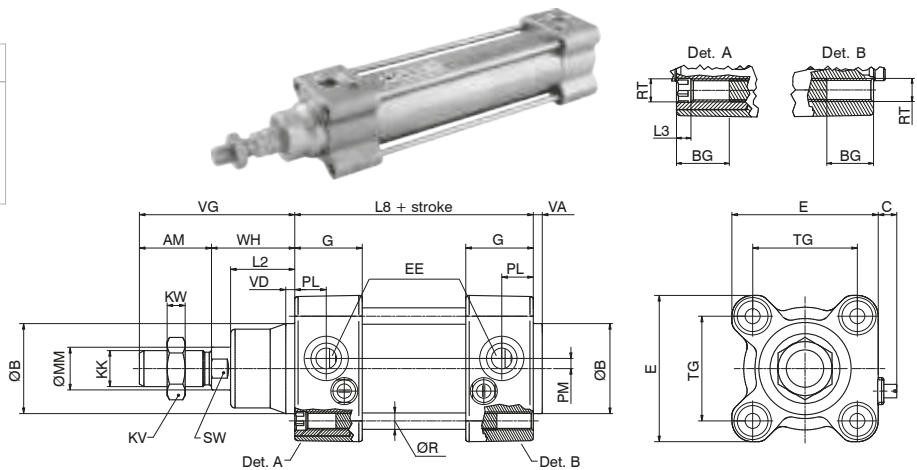

**Through rod cylinder version - "02"**

Ordering code

**1393.Ø.stroke.02** Magnetic  
**1394.Ø.stroke.02** Non magnetic

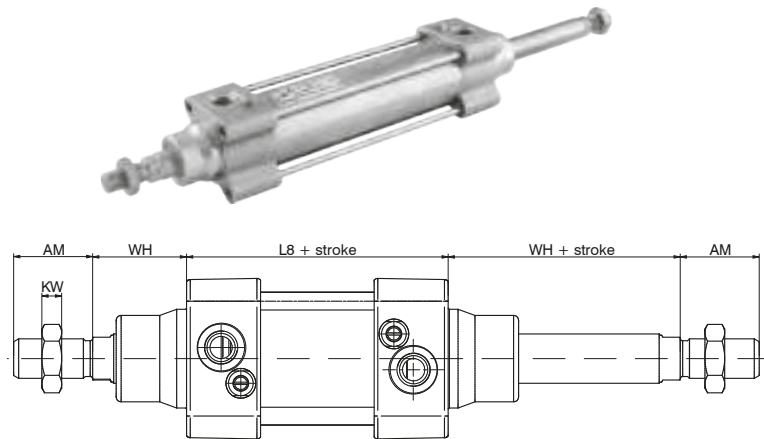

**Variants**

Version with FPM seals

Ordering code

**139\_(93.94) Ø.stroke.\_ \_ V**

**Table of dimensions**

Bore		32	40	50	63	80	100
AM		22	24	32	32	40	40
ØB (d 11)		30	35	40	45	45	55
BG min.		16	16	16	16	18	17
C	min.	4	4	4	4	3,5	3,5
	max.	7,5	7,5	8,5	8,5	9	9
E		47	52	65	76	95	113
EE		G1/8"	G1/4"	G1/4"	G3/8"	G3/8"	G1/2"
G		29	31	30	34	36	40,5
KK		M10X1,25	M12X1,25	M16X1,5	M16X1,5	M20x1,5	M20X1,5
KV		17	19	24	24	30	30
KW		16	7	8	8	9	9
L2		20	22	28,5	29	35	36
L3		4,5	4,5	5	5	6	6
L8		94	105	106	121	128	138
ØMM		12	16	20	20	25	25
PL		13	14	14	16	16	18
PM		3	3,5	4,5	7	8	8
ØR		Ø5,2	Ø5,2	Ø7,1	Ø7,1	Ø8,9	Ø8,9
RT		M6	M6	M8	M8	M10	M10
SW		10	13	17	17	22	22
TG		32,5	38	46,5	56,5	72	89
VA		4	4	4	4	4	4
VD		4	4	4	4	4	4
VG		48	54	69	69	86	91
WH		26	30	37	37	46	51
Weight	stroke 0	1000	1430	2150	3000	4400	6400
	every 10 mm	35	45	63	80	120	135

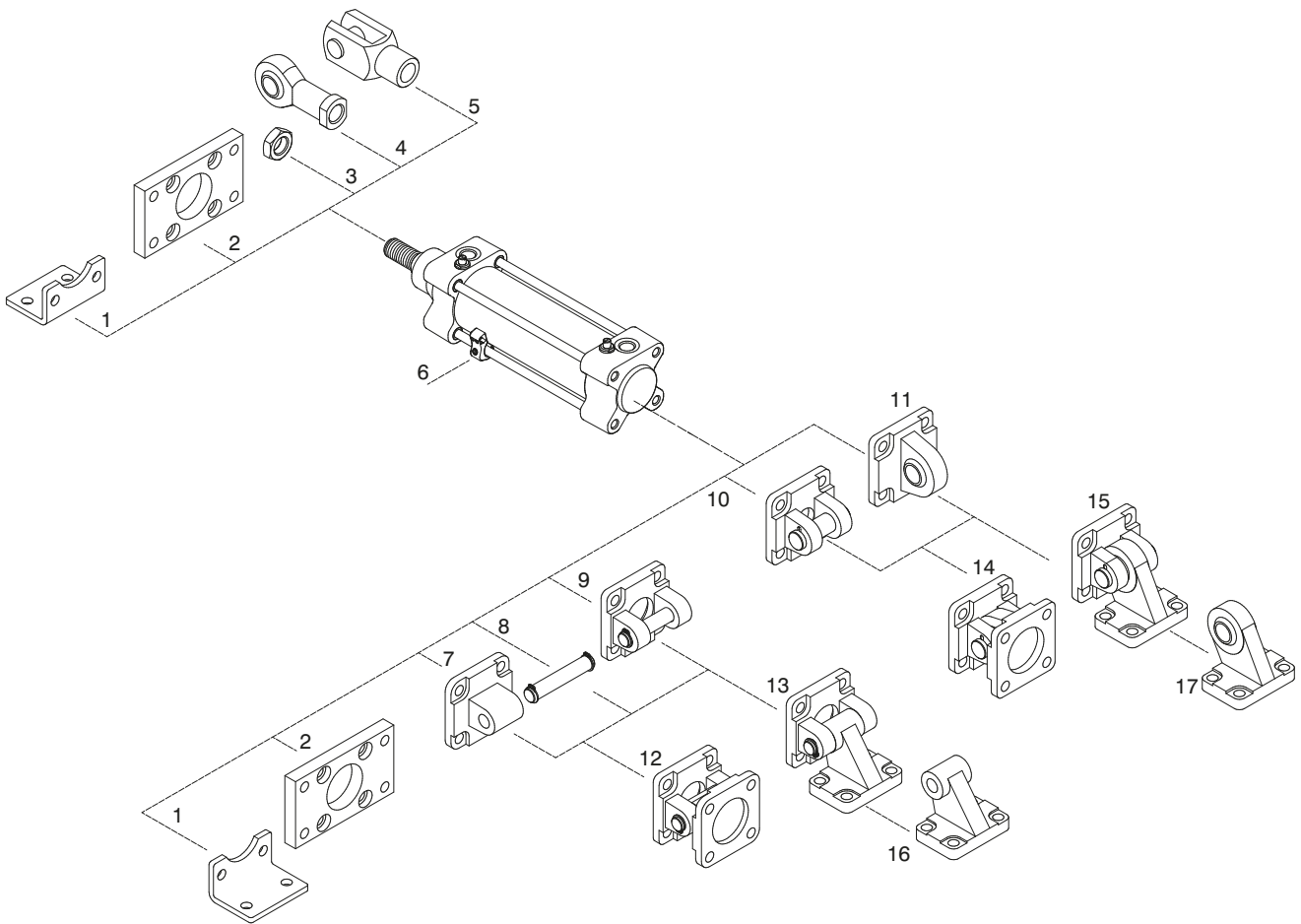

Position	Description	Ordering code	Materials
1	Short mounting foot brackets (MS1)	1393.0.05/1F	Stainless steel AISI 316
2	Flange (MF1-MF2)	1393.0.03F	Stainless steel AISI 316
3	Rod nut	1393.0.18F	Stainless steel AISI 316
4	Ball joint	1393.0.32F	Stainless steel
5	Fork	1393.0.13F	Stainless steel
6	Sensor bracket	1393._	Stainless steel AISI 316
7	Rear male clevis (MP4)	1393.0.09/1F	Stainless steel AISI 316
8	Pin (AA4) with circlips for rear clevis (MP2) (pos. 9)	1393.0.37F	Stainless steel AISI 316
9	Rear female clevis (MP2)	1393.0.09F	Stainless steel AISI 316
10	Rear narrow clevis (AB6)	1393.0.30F	Stainless steel AISI 316
11	Rear male clevis (with jointed head - MP6)	1393.0.15F	Stainless steel AISI 316
12	Standard complete trunnion (pos. 7 + pos. 9)	1393.0.22F	Stainless steel AISI 316
13	Square angle trunnion (pos. 9 + pos. 16)	1393.0.35F	Stainless steel AISI 316
14	Standard complete trunnion with jointed head (pos. 10 + pos.11)	1393.0.36F	Stainless steel AISI 316
15	Complete square angle trunnion (pos. 10 + pos.17)	1393.0.27F	Stainless steel AISI 316
16	Simple square counter clevis (AB7) (pos. 13)	1393.0.11/2F	Stainless steel AISI 316
17	Simple square counter clevis (pos. 15)	1393.0.28F	Stainless steel AISI 316

### Sensor bracket

Ordering code

**1393.A** (Ø32 ... Ø40)  
**1393.B** (Ø50 ... Ø63)  
**1393.C** (Ø80 ... Ø100)



Fixing bracket made of stainless steel AISI 316 for sensor mounting on cylinders.

Sensors cod. **1580.**\_  
**MRS.**\_  
**MHS.**\_



Bore	L
Ø32	51
Ø40	57
Ø50	67
Ø63	79
Ø80	98
Ø100	115

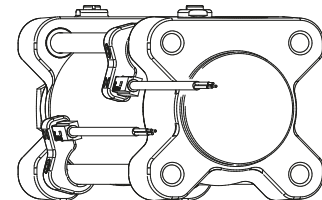
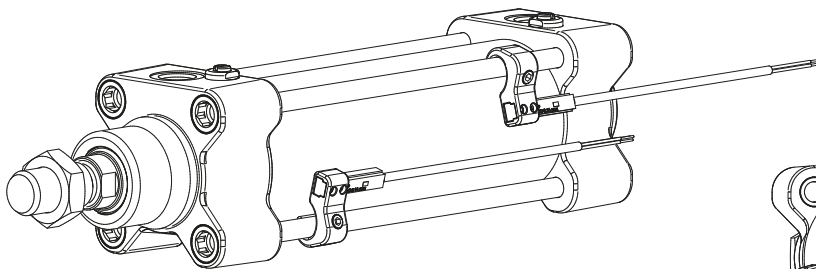
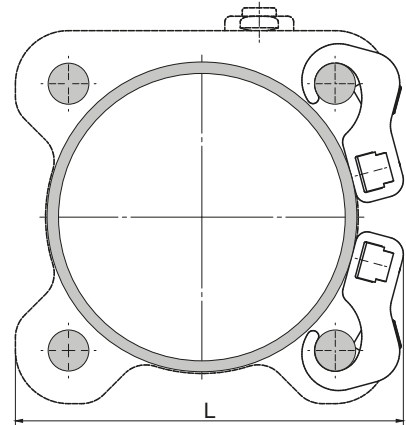

To mount the brackets on the tie rods use the dedicated stainless steel grub screw.

### Front and rear flanges (MF1 - MF2)

Ordering code

**1393.Ø.03F**



Plate in stainless steel AISI 316 which allows anchorage of the cylinder at a right angle to the plane.

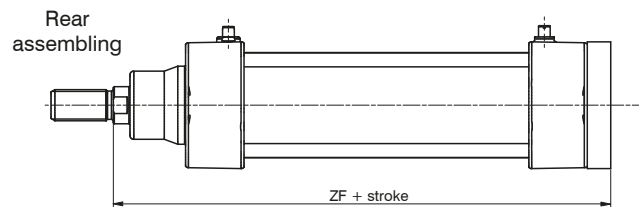
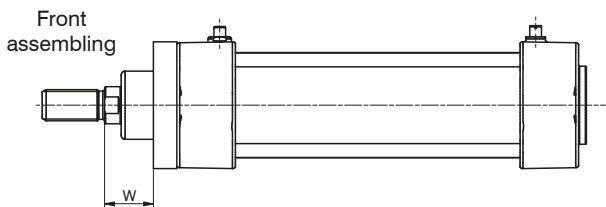
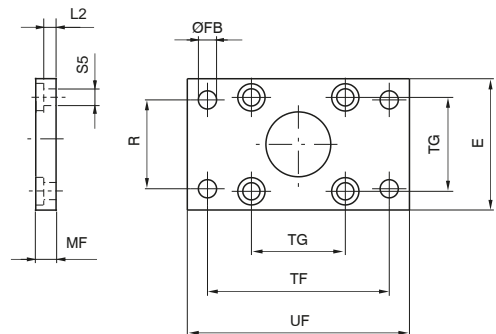

Bore	E	ØFB (H 13)	MF (JS 14)	R (JS 14)	TF (JS 14)	TG	UF	ZF	W	L2	ØS5	Weight (g)
32	45	7	10	32	64	32,5	80	130	16	5	6,6	190
40	52	9	10	36	72	38	90	145	20	5	6,6	250
50	65	9	12	45	90	46,5	110	155	25	6,5	9	480
63	75	9	12	50	100	56,5	120	170	25	6,5	9	620
80	95	12	15	63	126	72	150	189	31	7	11	1430
100	115	14	15	75	150	89	170	204	36	7	11	1990

► **Short mounting foot brackets (MS1)**

Ordering code
<b>1393.Ø.05/1F</b>

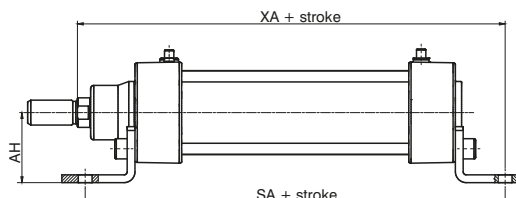
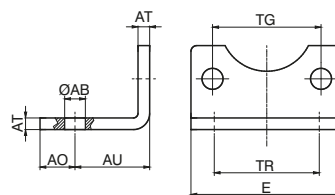

Elements used to anchor the cylinder parallel to the mounting plane. They are made of stainless steel AISI 316.

Bore	32	40	50	63	80	100
ØAB (H 14)	7	9	9	9	12	14
AH	32	36	45	50	63	71
AU (± 0.2)	24	28	32	32	41	41
AO	11	8	15	13	14	16
E	45	52	65	75	95	115
AT	4	4	5	5	6	6
SA	142	161	170	185	210	220
TG	32,5	38	46,5	56,5	72	89
TR (JS 14)	32	36	45	50	63	75
XA	144	163	175	190	215	230
Weight g	60	70	160	180	370	430

► **Rear clevis (MP2)**

Ordering code
<b>1393.Ø.09F</b>

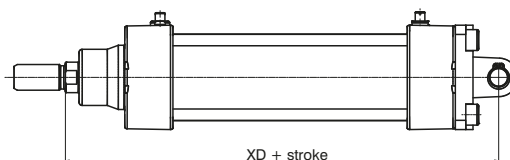
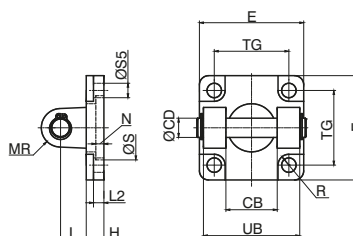

This type of mounting allows anchorage of the cylinder either parallel or right angle to plane; the cylinder rod can oscillate and self-align as necessary when under load. Made of stainless steel AISI 316.

Bore	32	40	50	63	80	100
CB (H 14)	26	28	32	40	50	60
ØCD	10	12	12	16	16	20
E	45	55	65	75	95	115
ØS (H11)	30	35	40	45	45	55
N	5	5	5	5	/	/
R (H13)	5,5	5,5	7,5	7,5	9	9
H	10	10	10	12	14	16
L	12	15	17	20	22	25
MR	10	12	12	16	16	20
TG	32,5	38	46,5	56,5	72	89
UB (h14)	45	52	60	70	90	110
XD	142	160	170	190	210	230
L2 (±0,5)	5,5	5,5	6,5	6,5	10	10
S5 (H13)	6,6	6,6	9	9	11	11
Weight g	140	230	370	540	1000	1700

**Rear male clevis (MP4)**

Ordering code

**1393.Ø.09/1F**

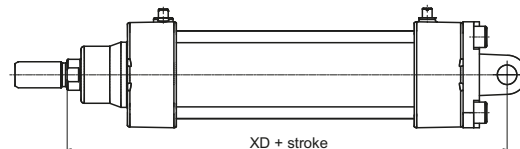
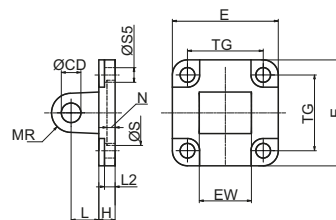

Similar to 09 clevis except for the connection, which is male rather than female. Used to mount the cylinder either parallel or at a right angle to the plane; the cylinder rod can oscillate and self-align as necessary when under load. Made of stainless steel AISI 316.

Bore	32	40	50	63	80	100
CD (H 9)	10	12	12	16	16	20
E	45	55	65	75	95	115
EW ( <sup>0.2</sup> / <sub>0.6</sub> )	26	28	32	40	50	60
H	10	10	10	12	14	16
L	12	15	17	20	22	25
ØS (H11)	30	35	40	45	45	55
N	5	5	5	5	/	/
R (H13)	5,5	5,5	7,5	7,5	9	9
MR	10	12	12	16	16	20
TG	32,5	38	46,5	56,5	72	89
XD	142	160	170	190	210	230
L2 (±0,5)	5,5	5,5	6,5	6,5	10	10
S5 (H13)	6,6	6,6	9	9	11	11
Weight g	180	280	370	680	1200	2100

**Pin with circlips for rear clevis (MP4 and MP2)**

Ordering code

**1393.Ø.37F**

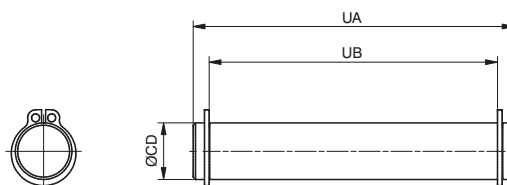

Stainless steel AISI 316 pin, complete with stainless steel circlips, which can be used with clevis code 1393.Ø.09/1F and 1393.Ø.09F

Bore	32	40	50	63	80	100
CD (e8)	10	12	12	16	16	20
UA	53	60	68	78	98	118
UB ( <sup>-0.5</sup> / <sub>0</sub> )	46	53	61	71	91	111
Weight g	35	50	60	120	150	290



► **Standard complete trunnion**

Ordering code  
**1393.Ø.22F**  
Mounting consists of rear clevis code 1380.Ø09F  
+rear male clevis code 1380.Ø.09/1F  
(ordering separately)

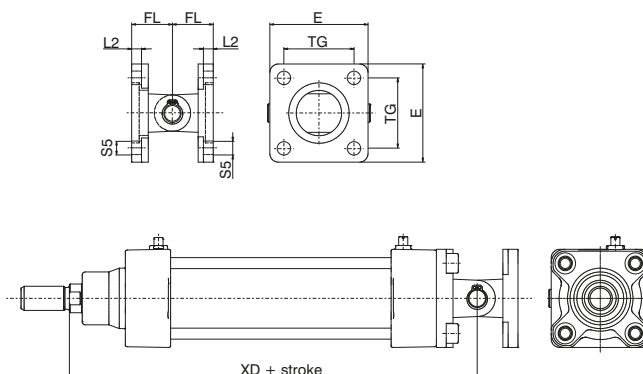

Made of stainless steel AISI 316.

Bore	32	40	50	63	80	100
E	45	55	65	75	95	115
FL	22	25	27	32	36	41
L 2 (±0,5)	5,5	5,5	6,5	6,5	10	10
S 5	6,6	6,6	9	9	11	11
TG	32,5	38	46,5	56,5	72	89
XD	142	160	170	190	210	230
Weight g	360	580	780	1370	2370	4110

► **Square angle trunnion (AB7)**

Ordering code  
**1393.Ø.35F**  
Counter clevis can be ordered  
separately with code 1393.Ø.11/2F

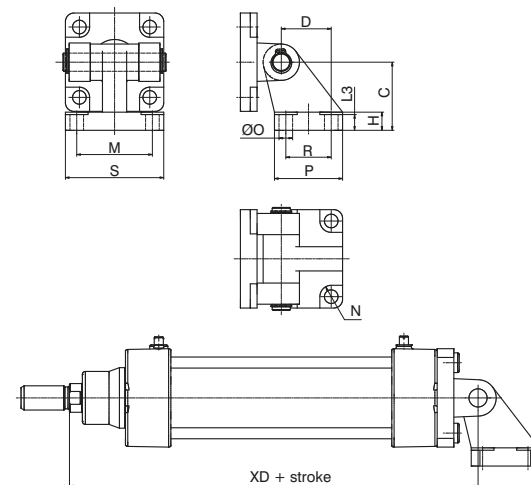

Made of stainless steel AISI 316.

Bore	32	40	50	63	80	100
D (JS 15)	21	24	33	37	47	55
C (JS 15)	32	36	45	50	63	71
H	8	10	12	12	14	15
N (H 13)	5,5	5,5	7,5	7,5	9	9
L3	6,5	8,5	10,5	10,5	11,5	12,5
R (JS 14)	18	22	30	35	40	50
P	31	35	45	50	60	70
O (H 13)	6,6	6,6	9	9	11	11
S	51	54	65	67	86	96
M (JS 14)	38	41	50	52	66	76
XD	142	160	170	190	210	230
Weight g	330	520	810	1200	2200	4710

**Rear narrow clevis (AB6)**

Ordering code

**1393.Ø.30F**

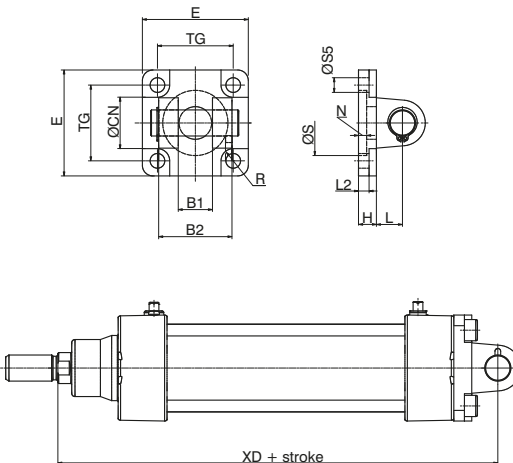

Bore	32	40	50	63	80	100
B1 (H 14)	14	16	21	21	25	25
B2 (h 14)	34	40	45	51	65	75
ØCN	10	12	16	16	20	20
E	45	55	65	75	95	115
H	10	10	10	12	14	16
L	12	15	17	20	22	25
L2 (±0,5)	5,5	5,5	6,5	6,5	10	10
S5 (H 13)	6,6	6,6	9	9	11	11
TG	32,5	38	46,5	56,5	72	89
XD	142	160	170	190	210	230
ØS (H 12)	30	35	40	45	45	55
R (H 13)	5,5	5,5	7,5	7,5	9	9
N	5	5	5	5	5	5
Weight g	170	270	420	650	1380	2050

Utilised with clevis 1393.Ø.15F allows the cylinder to oscillate in all directions (see standard complete trunnion 1393.Ø.36F)  
Made of stainless steel AISI 316.

**Rear male clevis (MP6) with jointed head according to DIN 648K standard**

Ordering code

**1393.Ø.15F**

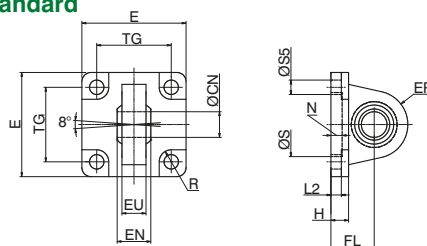

Bore	32	40	50	63	80	100
ØCN (H 7)	10	12	16	16	20	20
E	45	55	65	75	95	115
EN (-0.1)	14	16	21	21	25	25
ER	15	18	20	23	27	30
EU	10,5	12	15	15	18	18
FL (JS 15)	22	25	27	32	36	41
H	10	10	10	12	14	16
L2	5,5	5,5	6,5	6,5	10	10
S5 (H 13)	6,6	6,6	9	9	11	11
TG	32,5	38	46,5	56,5	72	89
XD	142	160	170	190	210	230
ØS (H 11)	30	35	40	45	45	55
R (H 13)	5,5	5,5	7,5	7,5	9	9
N	5	5	5	5	5	5
Weight g	150	260	370	600	1130	1800

Utilised with clevis 1393.Ø.30F allows the cylinder to oscillate in all directions.  
Made of stainless steel AISI 316.

3 PNEUMATIC ACTUATION

► **Standard complete trunnion with jointed head according to DIN 648K standard**

Ordering code  
**1393.Ø.36F**  
Mounting consists of rear narrow clevis  
code 1393.Ø.30F  
with rear male clevis code 1393.Ø.15F

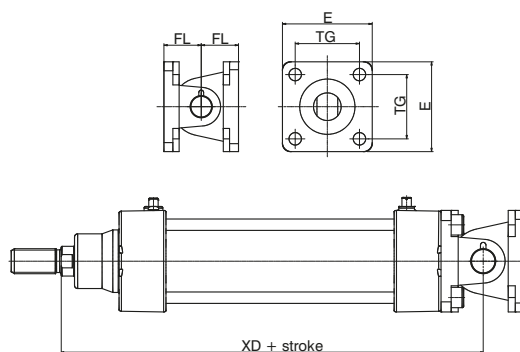

Made of stainless steel AISI 316.

Bore	32	40	50	63	80	100
E	45	55	65	75	95	115
FL (JS 15)	22	25	27	32	36	41
TG	32,5	38	46,5	56,5	72	89
XD	142	160	170	190	210	230
Weight g	320	530	790	1250	2510	3850

► **Complete square angle trunnion with jointed head acc. to DIN 648K standards**

Ordering code  
**1393.Ø.27F**  
Mounting consist of rear narrow clevis  
cod. 1393.Ø.30F  
with Simple square counter clevis cod. 1393.Ø.28F  
(ordering separately)

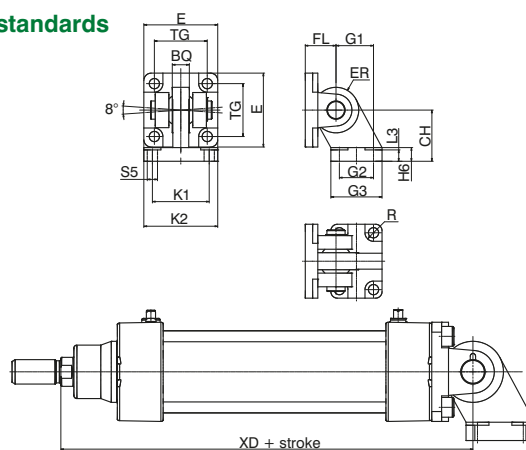

Made of stainless steel AISI 316.

Bore	32	40	50	63	80	100
CH (JS 15)	32	36	45	50	63	71
E	45	55	65	75	95	115
FL	22	25	27	32	36	41
G1 (JS 15)	21	24	33	37	47	55
G2 (JS 14)	18	22	30	35	40	50
G3	31	35	45	50	60	70
H6	10	10	12	12	14	15
K1 (JS 14)	38	41	50	52	66	76
K2	51	54	65	67	86	96
L3 (+0,5)	8,5	8,5	10,5	10,5	11,5	12,5
S5 (H13)	6,6	6,6	9	9	11	11
TG	32,5	38	46,5	56,5	72	89
XD	142	160	170	190	210	230
BQ	10,5	12	15	15	18	18
ER	15	18	20	23	27	30
R (H 13)	5,5	5,5	7,5	7,5	9	9
Weight g	350	540	880	1200	2350	3380

### Rod fork and nuts

Ordering code

1393.Ø.13F

1393.Ø.18F

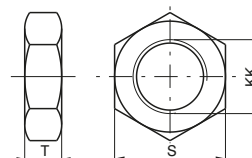
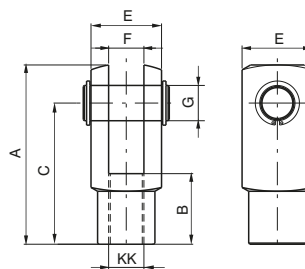

**Fork:**  
Element that when screwed to the rod consents a regular functioning even when there are significant lateral forces as the connection point.  
Made of stainless steel AISI 303.

**Nut:**  
Used to block the position of the fork.  
Made of stainless steel AISI 316.

Bore	32	40	50	63	80	100
A	52	62	83	83	105	105
B	20	24	32	32	40	40
C	40	48	64	64	80	80
E	20	24	32	32	40	40
F(B13)	10	12	16	16	20	20
G	10	12	16	16	20	20
S	17	19	24	24	30	30
T	6	7	8	8	9	9
KK	M10X1,25		M12X1,25	M16X1,5	M16X1,5	M20X1,5
Weight	fork	100	140	340	340	680
g	Nut	15	20	20	20	40

### Ball joint

Ordering code

1393.Ø.32F

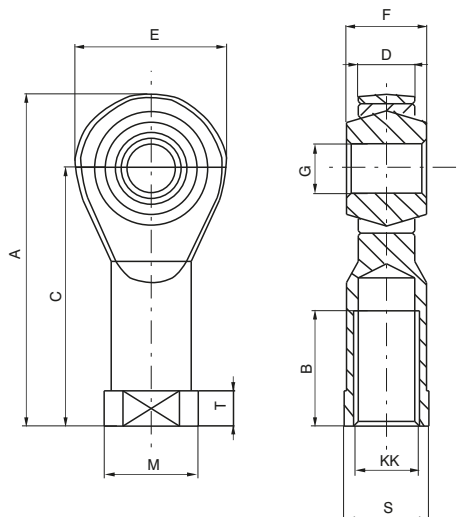

**Balljoint:**  
Mounted on the rod thread, assures a regular operation even in the presence of significant forces to the linked element.  
Made of stainless steel AISI 304 and 420.

Bore	32	40	50	63	80	100
A	57	66	85	85	102	102
B	20	22	28	28	33	33
C	43	50	64	64	77	77
D	10,5	12	15	15	18	18
E	28	32	42	42	50	50
F	14	16	21	21	25	25
G (H 7)	10	12	16	16	20	20
KK	M10x1,25	M12x1,25	M16x1,5	M16x1,5	M20x1,5	M20x1,5
M	19	22	27	27	34	34
S	17	19	22	22	30	30
T	6,5	6,5	8	8	10	10
Weight g	75	110	220	220	410	410

## Series 1450 - 1463 - Hydro-pneumatic speed control cylinders (Ø50 - Ø63)

### General

Pneumatic cylinder ISO 15552 handling and controlling movement by means of internal hydraulic circuit.  
All ISO fixing devices can be used except for:

- Cylinder Ø63 front clevis code 1463.63.08F
- Cylinder Ø63 front flange code 1463.63.03F
- Cylinder Ø63 foot code 1463.63.05/1F

### Ordering key

14 .stroke. . . .

Ø50  
Ø63

#### Regulation

- A = Regulation on extraction
- B = Regulation on compression
- D = Double regulation

#### STOP function

- 0 = None
- A = Stop N.C. extraction
- B = Stop N.C. compression
- C = Double Stop N.C.
- D = Stop N.O. extraction
- E = Stop N.O. compression
- F = Double Stop N.O.

#### SKIP function

- 0 = None
- A = Skip N.C. extraction
- B = Skip N.C. compression
- C = Double Skip N.C.
- D = Skip N.O. extraction
- E = Skip N.O. compression
- F = Double Skip N.O.

### Construction characteristics

End cap	aluminium black anodised
Piston Rod	steel tube externally chrome plated
Barrel	aluminium alloy anodised
Magnetic piston	aluminium
Cushion screw	nickel plated steel
Oil tank	aluminium
Pneumatic piston seal (pneumatic side)	oil resitant NBR rubber
Rod and cushion seal	PUR
Hydraulic piston seal (hydraulic side)	PUR

### Technical characteristics

Pneumatic media	filtered and lubricated air
Hydraulic media	filtered 1µ hydraulic oil
Maximum pressure	8 bar
Skip & Stop valve minimum operating pressure	3 bar
Environment temperature	-5°C +70°C
Minimum regulated speed	40 mm/min.
Maximum regulated speed	6000 mm/min. *
Speed with SKIP	150 mm/sec. *
Free speed (without regulation)	300 mm/sec. *
Cushion speed	20 mm *
Standard stroke	from 50 to 450 steps 50 mm
Possibility of rear regulation (on request)	

\* **Attention:** speed recorded with cylinder on horizontal position fed at 8 bar without load on piston rod.

### Force (N)

BORE	FORCE	PRESSURE (bar)									
		1	2	3	4	5	6	7	8	9	10
50	Extraction	181.4	362.9	544.3	725.7	907.2	1088.6	1270	1451.5	1632.9	1814.3
	Compression	144.4	288.8	433.2	577.6	722	866.3	1010.7	1155.1	1299.5	1443.9
63	Extraction	294.6	589.1	883.7	1178.2	1472.8	1767.3	2061.9	2356.5	2651	2945.6
	Compression	211.3	422.6	633.9	845.2	1056.6	1267.9	1479.2	1690.5	1901.8	2113.1

► Base cylinder dimensions

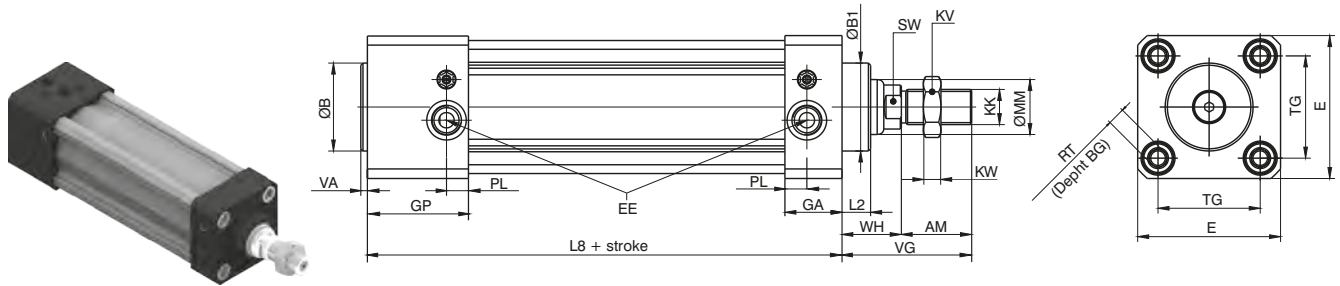

Bore	AM	B (d11)	B1 (d11)	BG	E	EE	GA	GP	KK	KV	KW	L2	L8	MM	PL	RT	SW	TG	VA	VG	WH
50	32	40	40	16	65	G1/4"	26	46	M16x1,5	24	8	13	116	25	10	M8	17	46,5	3	59	27
63		45	50		75	G3/8"			M16x1,5			20	121	35	12			56,5	4	69	37

Function valves and regulators position for the different versions

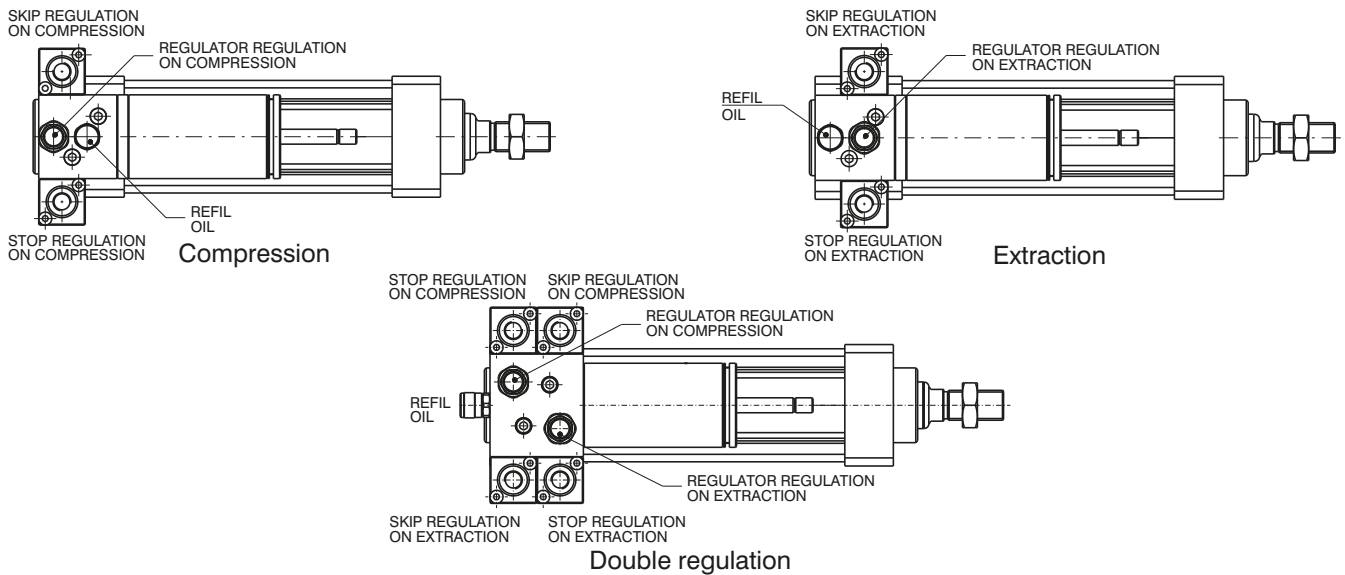

Rear regulator dimensions

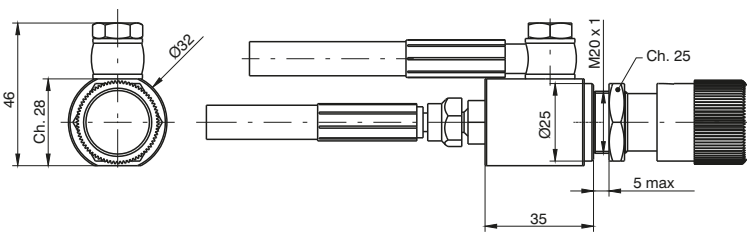

SKIP and STOP valves inlet feed position

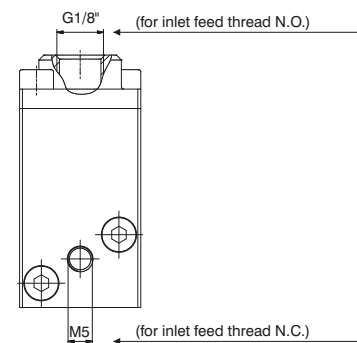

► Sensor brackets codes 1500., RS., HS.

Dimensions	
Bore	L
Ø50	77
Ø63	87

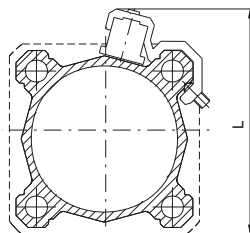

Ordering code  
**1320.B** Brackets for cylinder sensors Ø50 - Ø63

► Sensor brackets codes 1580., MRS., MHS.

Dimensions	
Bore	L
Ø50	66
Ø63	76

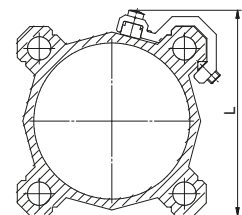

Ordering code  
**1320.BS** Brackets for cylinder sensors Ø50 - Ø63

Sensor for cylinder

For technical characteristics and code see "Magnetic sensor" section

► Regulation on the outward stroke

Ordering code
<b>14Ø.stroke.A.0.0</b>

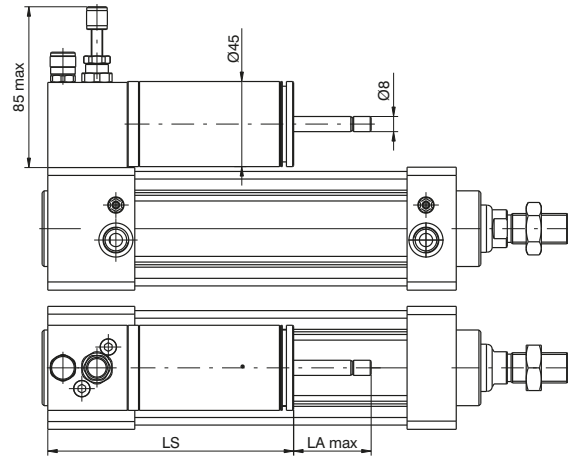

Ø50 Weight g 1970 + g 200 every 50 mm. stroke  
Ø63 Weight g 2591 + g 280 every 50 mm. stroke

Strokes	LS	LA max
0 ... 150	130	41
151 ... 350	185	66
351 ... 450	255	106

► Regulation on the inward stroke

Ordering code
<b>14Ø.stroke.B.0.0</b>

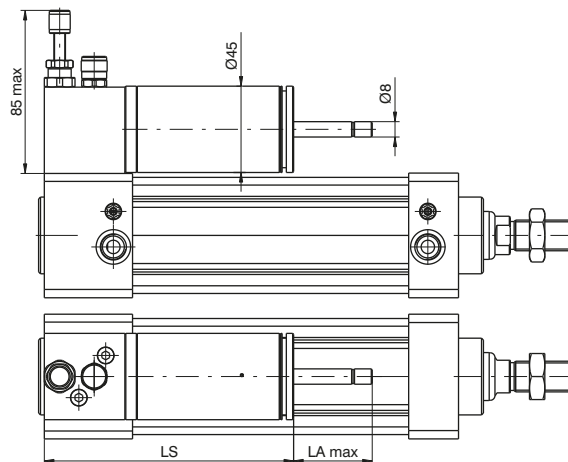

Ø50 Weight g 1970 + g 200 every 50 mm. stroke  
Ø63 Weight g 2591 + g 280 every 50 mm. stroke

Strokes	LS	LA max
0 ... 150	130	41
151 ... 350	185	66
351 ... 450	255	106

► Regulation in both directions

Ordering code
<b>14Ø.stroke.D.0.0</b>

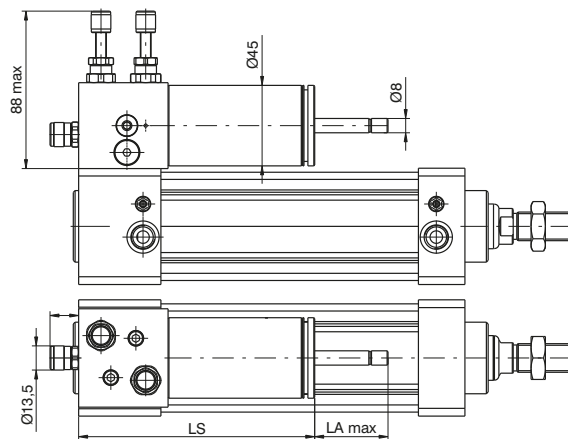

Ø50 Weight g 2128 + g 200 every 50 mm. stroke  
Ø63 Weight g 2749 + g 280 every 50 mm. stroke

Strokes	LS	LA max
0 ... 150	132	41
151 ... 350	187	66
351 ... 450	257	106

Regulation on the outward stroke with Skip N.O.

Ordering code  
**14Ø.stroke.A.0.D**

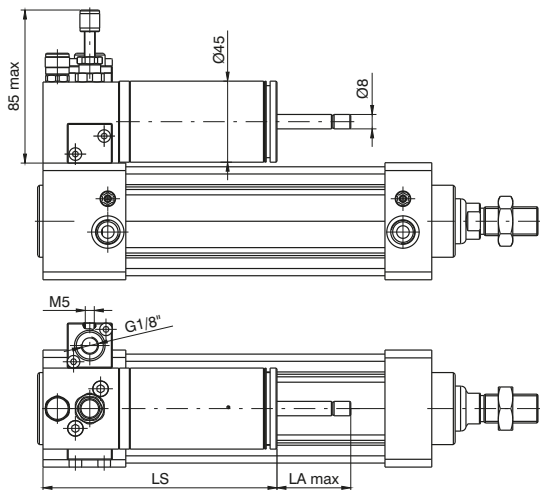

Ø50 Weight g 2059 + g 200 every 50 mm. stroke  
Ø63 Weight g 2928 + g 280 every 50 mm. stroke

Strokes	LS	LA max
0 ... 150	130	41
151 ... 350	185	66
351 ... 450	255	106

Regulation on the inward stroke with Skip N.O.

Ordering code  
**14Ø.stroke.B.0.E**

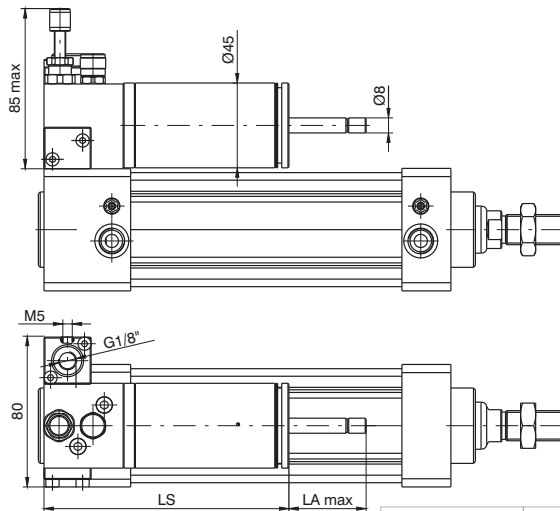

Ø50 Weight g 2059 + g 200 every 50 mm. stroke  
Ø63 Weight g 2928 + g 280 every 50 mm. stroke

Strokes	LS	LA max
0 ... 150	130	41
151 ... 350	185	66
351 ... 450	255	106

Regulation on the outward stroke with Stop N.O.

Ordering code  
**14Ø.stroke.A.D.0**

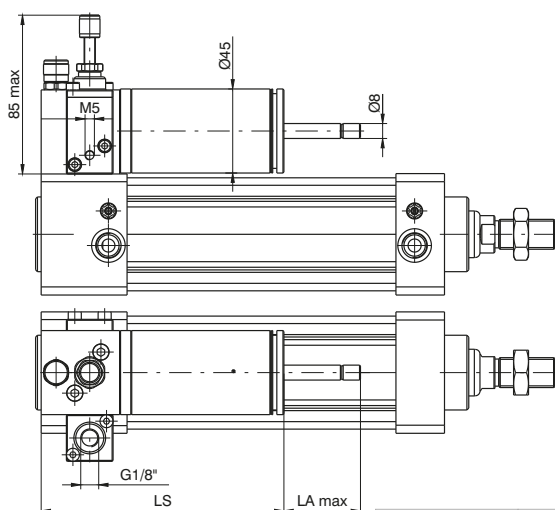

Ø50 Weight g 2059 + g 200 every 50 mm. stroke  
Ø63 Weight g 2928 + g 280 every 50 mm. stroke

Strokes	LS	LA max
0 ... 150	130	41
151 ... 350	185	66
351 ... 450	255	106



► Regulation on the inward stroke with Stop N.O.

Ordering code
<b>14Ø.stroke.B.E.0</b>



Ø50 Weight g 2059 + g 200 every 50 mm. stroke  
Ø63 Weight g 2928 + g 280 every 50 mm. stroke

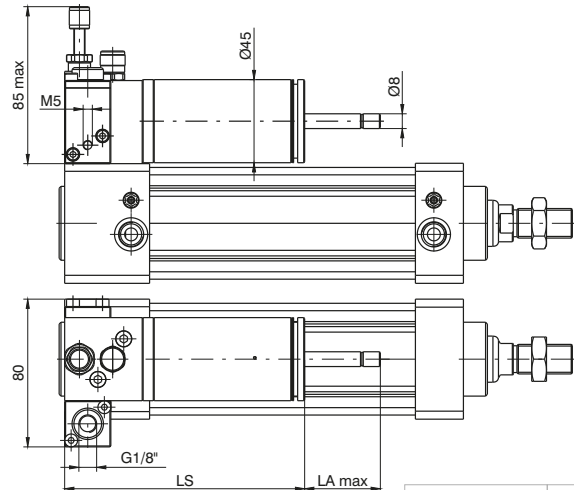

Strokes	LS	LA max
0 ... 150	130	41
151 ... 350	185	66
351 ... 450	255	106

► Regulation on the outward stroke with Skip N.O. - Stop N.O.

Ordering code
<b>14Ø.stroke.A.D.D</b>



Ø50 Weight g 2140 + g 200 every 50 mm. stroke  
Ø63 Weight g 2761 + g 280 every 50 mm. stroke

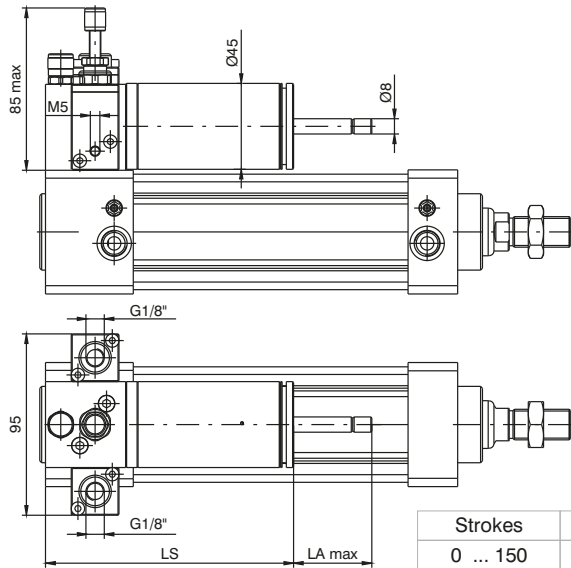

Strokes	LS	LA max
0 ... 150	130	41
151 ... 350	185	66
351 ... 450	255	106

► Regulation on the inward stroke with Skip N.O. - Stop N.O.

Ordering code
<b>14Ø.stroke.B.E.E</b>



Ø50 Weight g 2140 + g 200 every 50 mm. stroke  
Ø63 Weight g 2761 + g 280 every 50 mm. stroke

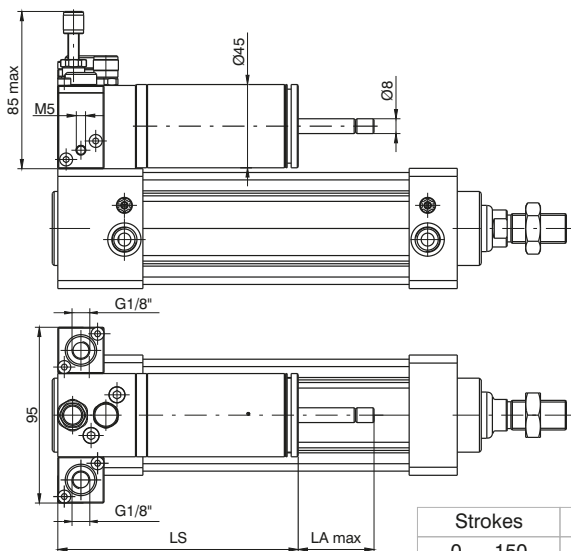

Strokes	LS	LA max
0 ... 150	130	41
151 ... 350	185	66
351 ... 450	255	106

► Regulation and Skip in both directions (N.O. Skip valves in both directions)

Ordering code  
**14Ø.stroke.D.0.F**

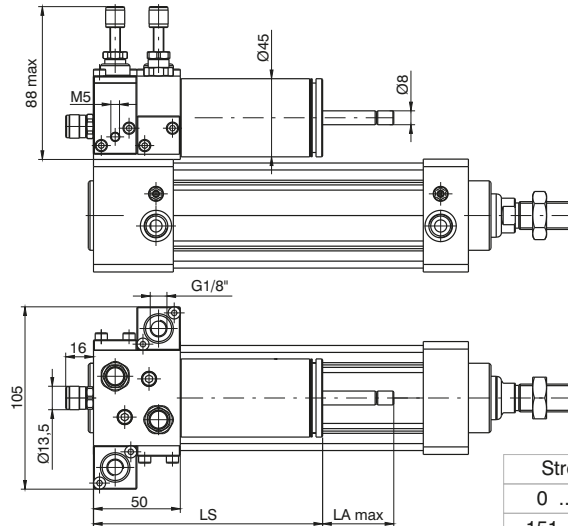

Strokes	LS	LA max
0 ... 150	132	41
151 ... 350	187	66
351 ... 450	257	106

Ø50 Weight g 2311 + g 200 every 50 mm. stroke  
Ø63 Weight g 2932 + g 280 every 50 mm. stroke

► Regulation and Stop in both directions (N.O. Stop valves in both directions)

Ordering code  
**14Ø.stroke.D.F.0**

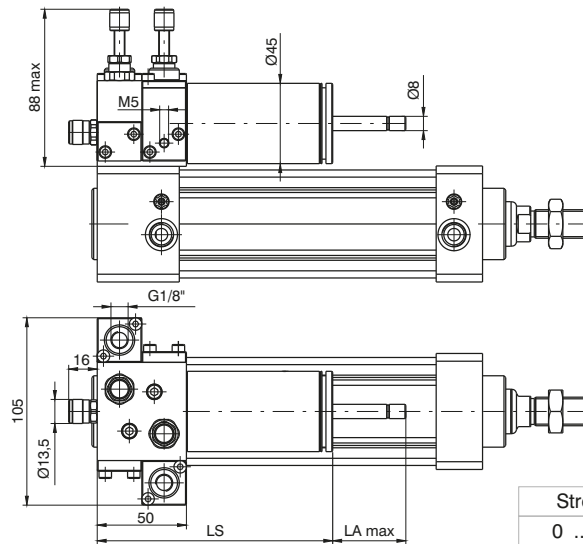

Strokes	LS	LA max
0 ... 150	132	41
151 ... 350	187	66
351 ... 450	257	106

Ø50 Weight g 2311 + g 200 every 50 mm. stroke  
Ø63 Weight g 2932 + g 280 every 50 mm. stroke

► Regulation with Skip and Stop in both directions (N.O. Skip and Stop valves in both directions)

Ordering code  
**14Ø.stroke.D.F.F**

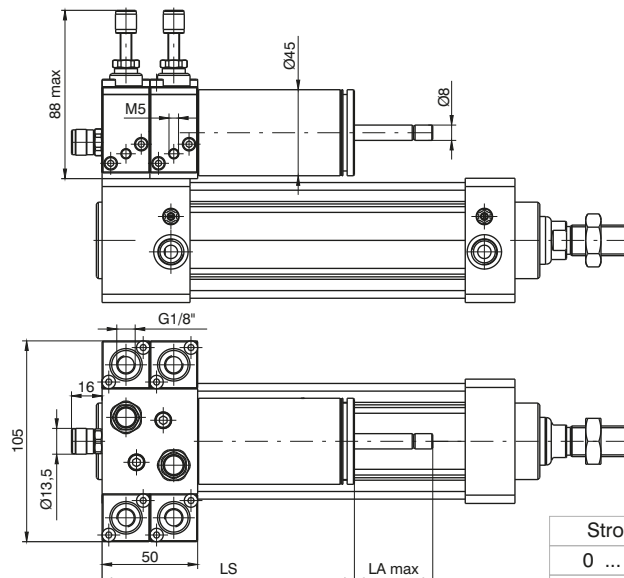

Strokes	LS	LA max
0 ... 150	132	41
151 ... 350	187	66
351 ... 450	257	106

Ø50 Weight g 2473 + g 200 every 50 mm. stroke  
Ø63 Weight g 3094 + g 280 every 50 mm. stroke



## Series 1500 - Compact cylinders according to standard ISO 21287 “ECOMPACT”

### General

These cylinders are built according to ISO 21287 standards. New barrel profile has two sensor slots on the three sides (Ø20 and Ø25 one slot) suitable for sensors 1580., MRS., MHS. series housing, without need for adaptors.

Versions with end stroke adjustable pneumatic cushioning are also available, allowing adjustments to deceleration and keeping the required overall dimensions according to ISO 21287.

For fixing operation is possible to use the four threaded holes on the end covers, or screws in body holes, alternatively all the fixing devices of UNITOP RU-P/6-P/7 (Ø20 and Ø25) and ISO 15552 (from Ø32 to Ø100) series.

### Construction characteristics

Body	anodised aluminium
End cap	aluminium alloy casting painted
Bearing piston rod	sintered bronze
Piston rod	from Ø20 to Ø25 stainless steel from Ø32 to Ø100 C43 chromed (on request stainless steel)
Piston	from Ø20 to Ø40 acetal resin (aluminium on request), Ø50 and Ø100 aluminium (with FPM seals, aluminium piston for all standard diameters)
Seals	Standard: NBR oil resistant rubber, PUR piston rod seals (PUR or FPM seals available upon request)
Spring	stainless steel
Fixing screws	plated zinc steel

### Operational characteristics

Fluid	Filtered air. No lubrication needed, if applied it shall be continuous.
Max. pressure	10 bar
Operating temperature	-5°C - +70°C with standard seals (magnetic or non magnetic piston) -30°C - +80°C with PUR seals (magnetic or non magnetic piston) -5°C - +80°C with FPM seals (magnetic piston) -5°C - +150°C with FPM seals (non magnetic piston)

Please follow the suggestions below to ensure a long life for these cylinders:

- use clean and lubricated air
- correct alignment during assembly with regard to the applied load so as to avoid radial components or bending the rod.
- avoid high speeds together with long strokes and heavy loads: this would produce kinetic energy which the cylinder cannot absorb, especially if used as a limit stop (in this case use mechanical stop device and aluminium piston)
- evaluate the environmental characteristics of cylinder used (high temperature, hard atmosphere, dust, humidity etc.)

**Please note: air must be dried for applications with lower temperature.**

Use hydraulic oils H class (ISO VG32) for correct continued lubrication.

Our Technical Department will be glad to help.

### Stroke tolerance, minimum and maximum spring loads and cushioning length

Bore (mm)	Stroke tolerance (mm)	Minimum and maximum springs load (N)		Cushioning length (mm)
		min.	max.	
Ø20	+1.5 / 0 mm	10.8	19.6	/
Ø25		16.7	22.6	5
Ø32	+2 / 0 mm	19.6	25.5	6.5
Ø40		25.5	42.2	8
Ø50		44.1	96.3	7.5
Ø63	+2.5 / 0mm	44.1	96.3	7.5
Ø80		63.8	100.1	8
Ø100		107.9	193.3	12



Standard stroke

DOUBLE ACTING  
BASIC version  
and  
THROUGH ROD CYLINDER  
version

Bore	Stroke																												
	5	10	15	20	25	30	35	40	45	50	55	60	65	70	75	80	100	125	150	160	200	250	300	320	350	400	450	500	
	<b>WITHOUT CUSHIONING DEVICE</b>																												
Ø20	●	●	●	●	●	●	●	●	●	●	●	●	●	●	●	●	●	●	●	●	●	●	●	●	●	●	●	●	●
Ø25	●	●	●	●	●	●	●	●	●	●	●	●	●	●	●	●	●	●	●	●	●	●	●	●	●	●	●	●	●
Ø32	●	●	●	●	●	●	●	●	●	●	●	●	●	●	●	●	●	●	●	●	●	●	●	●	●	●	●	●	●
Ø40	●	●	●	●	●	●	●	●	●	●	●	●	●	●	●	●	●	●	●	●	●	●	●	●	●	●	●	●	●
Ø50	●	●	●	●	●	●	●	●	●	●	●	●	●	●	●	●	●	●	●	●	●	●	●	●	●	●	●	●	●
Ø63	●	●	●	●	●	●	●	●	●	●	●	●	●	●	●	●	●	●	●	●	●	●	●	●	●	●	●	●	●
Ø80	●	●	●	●	●	●	●	●	●	●	●	●	●	●	●	●	●	●	●	●	●	●	●	●	●	●	●	●	●
Ø100	●	●	●	●	●	●	●	●	●	●	●	●	●	●	●	●	●	●	●	●	●	●	●	●	●	●	●	●	●
	<b>WITH CUSHIONING DEVICE</b>																												
Ø20																													
Ø25					●	●	●	●	●	●	●	●	●	●	●	●	●	●	●	●	●	●	●	●	●	●	●	●	●
Ø32					●	●	●	●	●	●	●	●	●	●	●	●	●	●	●	●	●	●	●	●	●	●	●	●	●
Ø40					●	●	●	●	●	●	●	●	●	●	●	●	●	●	●	●	●	●	●	●	●	●	●	●	●
Ø50					●	●	●	●	●	●	●	●	●	●	●	●	●	●	●	●	●	●	●	●	●	●	●	●	●
Ø63					●	●	●	●	●	●	●	●	●	●	●	●	●	●	●	●	●	●	●	●	●	●	●	●	●
Ø80					●	●	●	●	●	●	●	●	●	●	●	●	●	●	●	●	●	●	●	●	●	●	●	●	●
Ø100					●	●	●	●	●	●	●	●	●	●	●	●	●	●	●	●	●	●	●	●	●	●	●	●	●

DOUBLE ACTING  
THROUGH ROD CYLINDER  
BORED version

Bore	Stroke																																	
	5	10	15	20	25	30	35	40	45	50	55	60	65	70	75	80	25	30	35	40	45	50	55	60	65	70	75	80						
	<b>WITHOUT CUSHIONING DEVICE</b>																	<b>WITH CUSHIONING DEVICE</b>																
Ø20	●	●	●	●	●	●	●	●	●	●	●	●	●	●	●	●																		
Ø25	●	●	●	●	●	●	●	●	●	●	●	●	●	●	●	●	●	●	●	●	●	●	●	●	●	●	●	●	●					
Ø32	●	●	●	●	●	●	●	●	●	●	●	●	●	●	●	●	●	●	●	●	●	●	●	●	●	●	●	●	●					
Ø40	●	●	●	●	●	●	●	●	●	●	●	●	●	●	●	●	●	●	●	●	●	●	●	●	●	●	●	●	●					
Ø50	●	●	●	●	●	●	●	●	●	●	●	●	●	●	●	●	●	●	●	●	●	●	●	●	●	●	●	●	●					
Ø63	●	●	●	●	●	●	●	●	●	●	●	●	●	●	●	●	●	●	●	●	●	●	●	●	●	●	●	●	●					
Ø80	●	●	●	●	●	●	●	●	●	●	●	●	●	●	●	●	●	●	●	●	●	●	●	●	●	●	●	●	●					
Ø100	●	●	●	●	●	●	●	●	●	●	●	●	●	●	●	●	●	●	●	●	●	●	●	●	●	●	●	●	●					

DOUBLE ACTING version  
WITH NON-ROTATING DEVICE

Bore	Stroke																																	
	5	10	15	20	25	30	35	40	45	50	55	60	65	70	75	80	25	30	35	40	45	50	55	60	65	70	75	80						
	<b>WITHOUT CUSHIONING DEVICE</b>																	<b>WITH CUSHIONING DEVICE</b>																
Ø20	●	●	●	●	●	●	●	●	●	●	●	●	●	●	●	●																		
Ø25	●	●	●	●	●	●	●	●	●	●	●	●	●	●	●	●	●	●	●	●	●	●	●	●	●	●	●	●	●					
Ø32	●	●	●	●	●	●	●	●	●	●	●	●	●	●	●	●	●	●	●	●	●	●	●	●	●	●	●	●	●					
Ø40	●	●	●	●	●	●	●	●	●	●	●	●	●	●	●	●	●	●	●	●	●	●	●	●	●	●	●	●	●					
Ø50	●	●	●	●	●	●	●	●	●	●	●	●	●	●	●	●	●	●	●	●	●	●	●	●	●	●	●	●	●					
Ø63	●	●	●	●	●	●	●	●	●	●	●	●	●	●	●	●	●	●	●	●	●	●	●	●	●	●	●	●	●					
Ø80	●	●	●	●	●	●	●	●	●	●	●	●	●	●	●	●	●	●	●	●	●	●	●	●	●	●	●	●	●					
Ø100	●	●	●	●	●	●	●	●	●	●	●	●	●	●	●	●	●	●	●	●	●	●	●	●	●	●	●	●	●					

SINGLE ACTING  
version

Bore	Stroke				
	5	10	15	20	25
Ø20	●	●	●	●	●
Ø25	●	●	●	●	●
Ø32	●	●	●	●	●
Ø40	●	●	●	●	●
Ø50	●	●	●	●	●
Ø63	●	●	●	●	●
Ø80	●	●	●	●	●
Ø100	●	●	●	●	●

PNEUMATIC ACTUATION 3

**BASIC version**  
double and single acting



Ø20 and Ø25

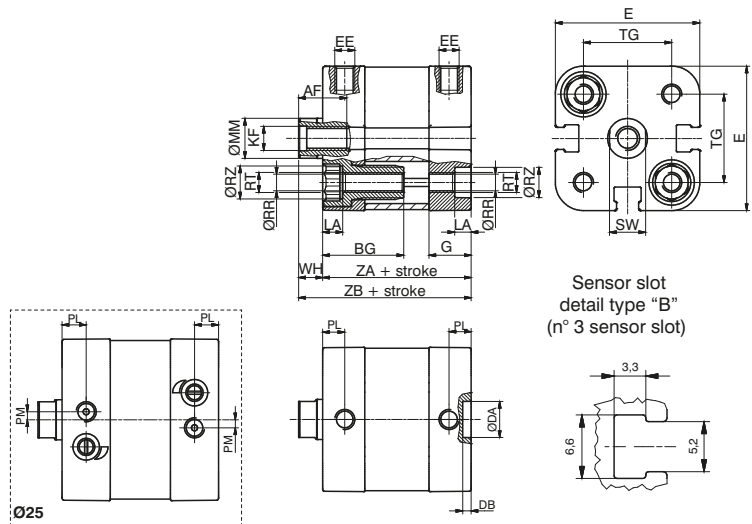

from Ø32 to Ø63

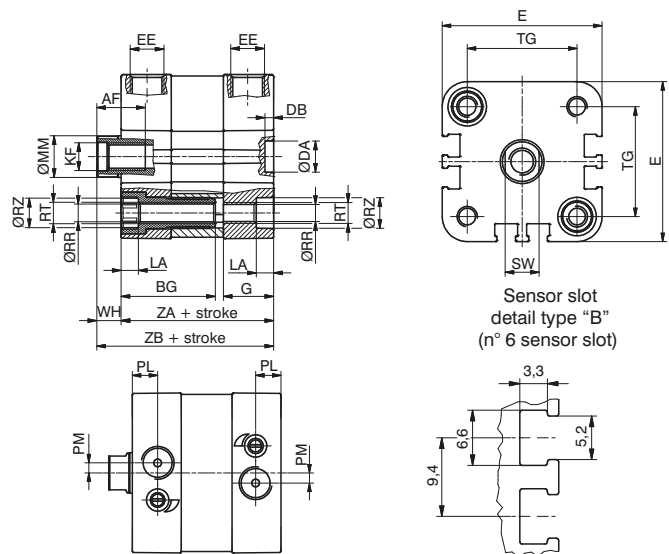

Ø80 and Ø100

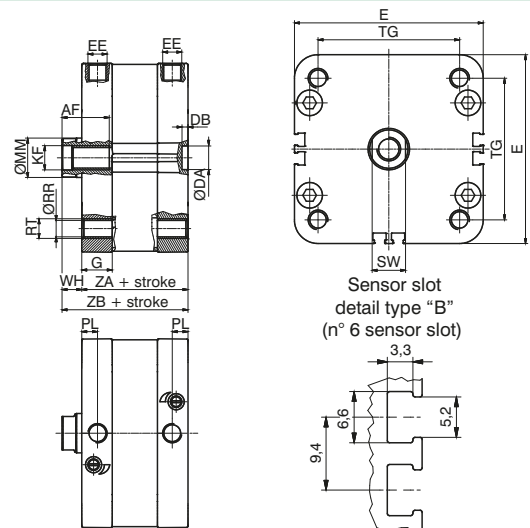

**THROUGH ROD CYLINDER version**  
double and single acting

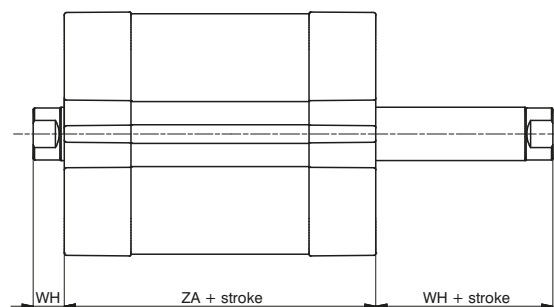

3 PNEUMATIC ACTUATION

**TANDEM version**

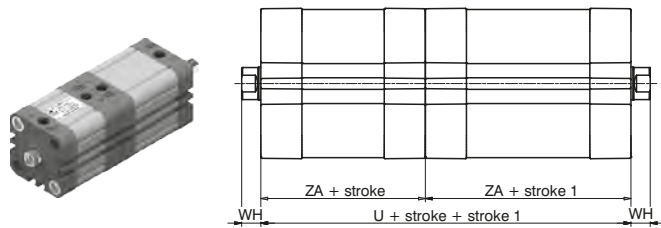

Tandem with opposed rods

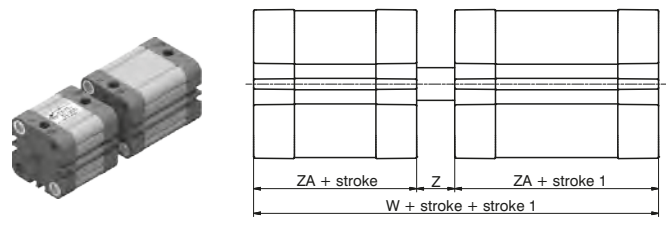

Opposed tandem with common rods

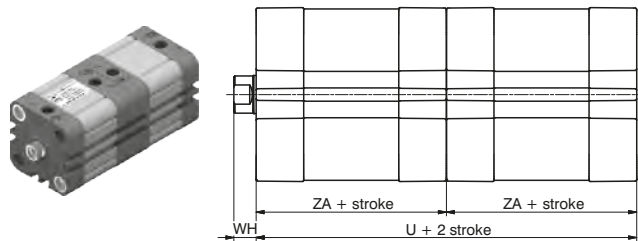

Tandem push with common rod

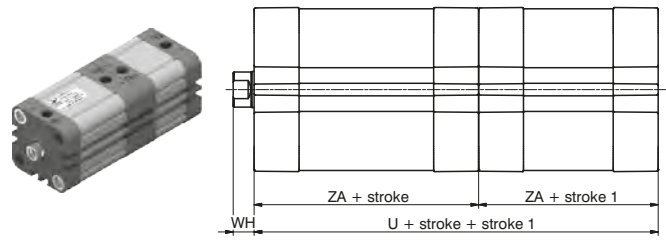

Tandem push with independent rod

**Basic and Through rod version**

**Ordering code**

**TANDEM version (magnetic pistons)**

- 15 . Ø . stroke . .
- 1 = magnetic piston, Double acting
  - 2 = magnetic piston, Single acting with front spring
  - 3 = magnetic piston, Single acting with rear spring
  - 4 = non magnetic piston, Double acting
  - 5 = non magnetic piston, Single acting with front spring
  - 6 = non magnetic piston, Single acting with rear spring
- 01 = Basic, female threaded rod
  - 02 = Basic, male threaded rod
  - 03 = through rod, female threaded rod
  - 04 = through rod, male threaded rod
  - \*\* 05 = through rod, bored female threaded rod
  - 06 = through rod, bored male threaded rod
  - 07 = with non-rotating device
  - 08 = through rod, female threaded rod, with non-rot. device on one side \*\*\*
  - 09 = through rod, male threaded rod, with non-rot. device on one side \*\*\*
- 0 = NBR seals and C43 chromed plated rod\*
  - 1 = NBR seals and stainless steel rod (starting from bore Ø32)
  - 4 = PUR seals and C43 chromed plated rod \*
  - 5 = PUR seals and stainless steel rod (starting from bore Ø32)
  - 6 = FPM seals and C43 chromed plated rod\*
  - 7 = FPM seals and stainless steel rod (starting from bore Ø32)
- \* (Ø20 and Ø25 stainless steel)
- 4 = Non-cushioned versions (mechanical cushioning only)
  - 5 = Versions with adjustable end of stroke cushioning system (from Ø25)

\*\* It is possible to order the Ø20, Ø25, Ø32 and Ø40 cylinders with an aluminium piston by replacing the '0' with 'K' in the ordering code.  
Example: 1540.20.10.01.1 (Acetyl Resin Piston)

1540.20.10.K1.1 (Aluminium Piston version)

\*\*\* for single acting version, the spring is on the anti-rotation side

**Table of dimensions**

Bore	Ø20	Ø25	Ø32	Ø40	Ø50	Ø63	Ø80	Ø100
AF (min)	12	12	14	14	18	18	24	24
BG	20	20	16	16	16	16	/	/
DA (H9) Ø	9	9	9	9	12	12	12	12
DB (+0.1/0)	2.1	2.1	2.5	2.5	2.6	2.6	3	3
E (max)	36	40.5	47.5	55	66	78	96	116
EE	M5	M5	G1/8	G1/8	G1/8	G1/8	G1/8	G1/8
G	10.5	12	14.5	15	15	15	15.5	18.5
KF	M6	M6	M8	M8	M10	M10	M12	M12
LA (0/-0.1)	4.1	4.1	5	5	5	5	/	/
MM (f7) Ø	10	10	12	12	16	16	20	25
PL (+0.1/0)	5.5	6	7.5	8	8	8	8	8
PM	/	2	3	/	/	/	/	/
RR (min) Ø	4.1	4.1	5.1	5.1	6.6	6.6	8.4	8.4
RT	M5	M5	M6	M6	M8	M8	M10	M10
RZ (min) Ø	7.5	7.5	8.5	8.5	10.5	10.5	/	/
SW (0/-0.1)	9	9	10	10	13	13	17	22
TG (±0.2)	22	26	32.5	38	46.5	56.5	72	89
U	74	78	88	90	90	98	108	134
W	83	89	100	103	105	113	124	154
WH (±1)	6	6	7	7	8	8	10	10
Z	9	11	12	13	15	15	16	20
ZA (±0.5)	37	39	44	45	45	49	54	67
ZB (+1/0)	43	45	51	52	53	57	64	77
Weight stroke	105	110	200	270	420	550	760	1400
gr. every 5mm	10	10.5	13	17	23.5	27	37	51

- 15 . Ø . stroke . (stroke 1) . .
- C = female threaded rod
  - G = male threaded rod
  - H = with through rod and female threaded rod
  - R = with through rod and male threaded rod
  - N = with non-rotating device
- B = female threaded rod
  - F = male threaded rod
  - M = with non-rotating device
  - P = with through rod and female threaded rod
  - Q = with through rod and male threaded rod
- D = Opposed tandem with common rod
- A = female threaded rod
  - E = male threaded rod
  - L = with non-rotating device on both ends
- 0 = NBR seals and C43 chromed plated rod\*
  - 1 = NBR seals and stainless steel rod (starting from bore Ø32)
  - 4 = PUR seals and C43 chromed plated rod\*
  - 5 = PUR seals and stainless steel rod (starting from bore Ø32)
  - 6 = FPM seals and C43 chromed plated rod\*
  - 7 = FPM seals and stainless steel rod (starting from bore Ø32)
- \* (Ø20 and Ø25 stainless steel)
- 4 = Non-cushioned version (mechanical cushioning only)
  - 5 = Versions with adjustable end of stroke cushioning system (from Ø25)

Seals compounds scheme: **NBR** oil resistant nitrilic rubber  
**PUR**: polyurethane seals **FPM**: fluoropolymer rubber seals

3 PNEUMATIC ACTUATION

► Basic version male piston rod

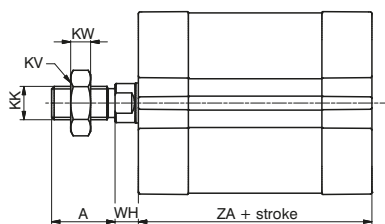

► Through rod version male rod

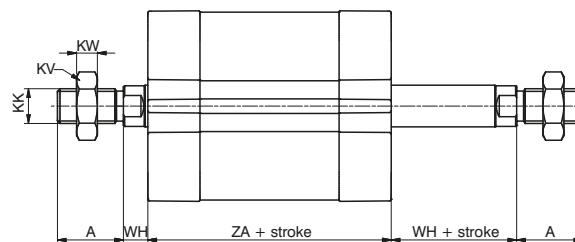

► Through rod version bored female piston rod

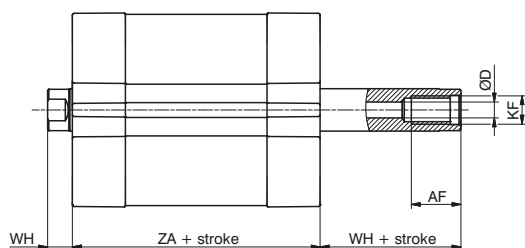

► Through rod version bored male piston rod

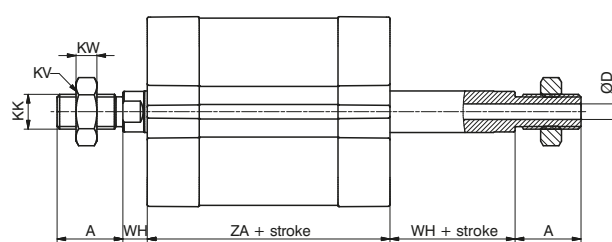

► Non-rotating version

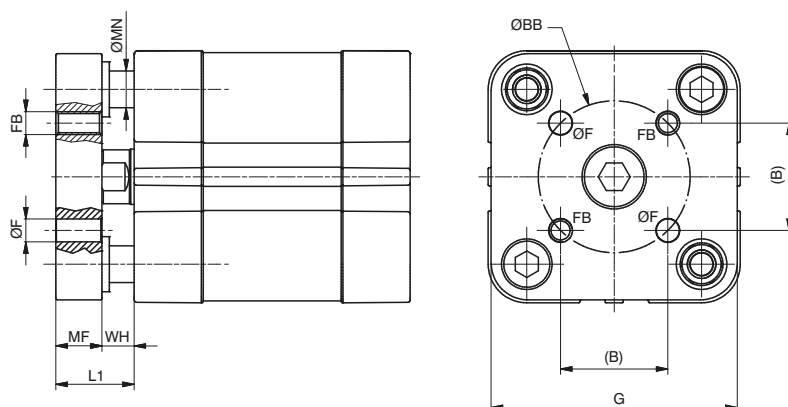

Bore	Ø20	Ø25	Ø32	Ø40	Ø50	Ø63	Ø80	Ø100
A (0/-0,5)	16	16	19	19	22	22	28	28
AF (min)	12	12	14	14	18	18	24	24
B	12	15,6	19,8	23,3	29,7	35,4	46	56,6
BB (±0,1) Ø	17	22	28	33	42	50	65	80
D Ø	3	3,8	4,5	4,5	6	6	8	10
F (+0,1/0) Ø	4	5	5	5	6	6	8	10
FB	M4	M5	M5	M5	M6	M6	M8	M10
G	35	39,5	45	52	65	75	95	115
KF	M6	M6	M8	M8	M10	M10	M12	M12
KK	M8x1,25	M8x1,25	M10x1,25	M10x1,25	M12x1,25	M12x1,25	M16x1,5	M16x1,5
KV	13	13	17	17	19	19	24	24
KW	5	5	6	6	7	7	8	8
L1	14	14	17	17	20	20	24	24
MF (+0,1/0)	8	8	10	10	12	12	14	14
MN (f 7) Ø	6	6	8	8	10	10	12	12
WH (±1)	6	6	7	7	8	8	10	10
ZA (±0,5)	37	39	44	45	45	49	54	67



Sensor and piston rod accessories

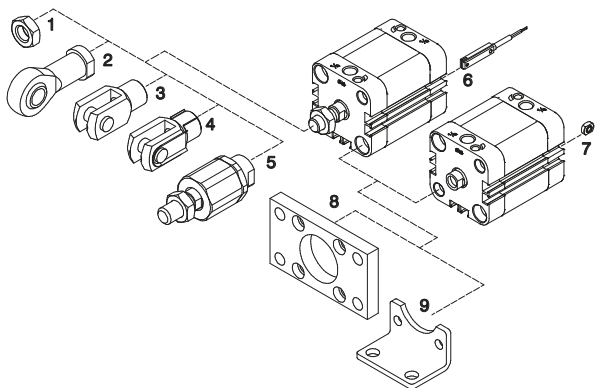

Pos.	Description	Ordering code	
		Aluminium	Steel
1	Rod lock nut	1200.20.06	(Ø20-Ø25)
		1320.32.18F	(Ø32-Ø40)
		1320.40.18F	(Ø50-Ø63)
		1320.50.18F	(Ø80-Ø100)
2	Ball joint	1200.20.32F	(Ø20-Ø25)
		1320.32.32F	(Ø32-Ø40)
		1320.40.32F	(Ø50-Ø63)
		1320.50.32F	(Ø80-Ø100)
3	Fork	1200.20.04	(Ø20-Ø25)
		1320.32.13F	(Ø32-Ø40)
		1320.40.13F	(Ø50-Ø63)
		1320.50.13F	(Ø80-Ø100)
4	Fork with clips	1200.20.04/1	(Ø20-Ø25)
		1320.32.13/1F	(Ø32-Ø40)
		1320.40.13/1F	(Ø50-Ø63)
		1320.50.13/1F	(Ø80-Ø100)
5	Self-aligning joint	1200.20.33F	(Ø20-Ø25)
		1320.32.33F	(Ø32-Ø40)
		1320.40.33F	(Ø50-Ø63)
		1320.50.33F	(Ø80-Ø100)
6	Sensors	(See chapter 6 magnetic sensors)	
7	Valves direct mounting bolt	1500.20F	(Ø20 - Ø100)

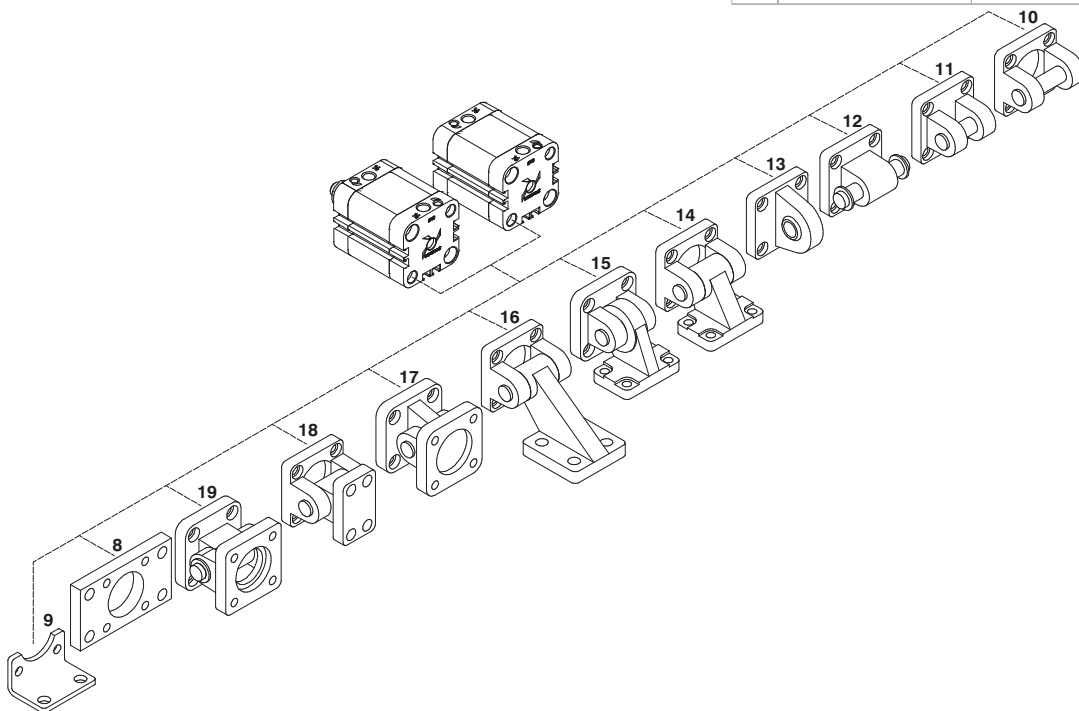

Fixing

Pos.	Description	Ordering code	
		Aluminium	Steel
8	Flange (MF2)	/	1540.Ø.03F (Ø20 - Ø25)
		/	1380.Ø.03F (Ø32 - Ø100)
9	Foot (MS1)	/	1540.Ø.05/1F (Ø20 - Ø100)
10	Rear female clevis (MP2)	1380.Ø.09F (Ø32 - Ø100)	1320.Ø.20F (Ø32 - Ø100)
11	Narrow rear female trunnion (AB6)	1380.Ø.30F (Ø32 - Ø100)	1320.Ø.29F (Ø32 - Ø100)
12	Rear male clevis (MP4)	1580.Ø.09/1F (Ø20 - Ø25)	1580.Ø.09/2F (Ø20 - Ø25)
		1380.Ø.09/1F (Ø32 - Ø100)	1320.Ø.21F (Ø32 - Ø100)
13	Rear male clevis (with jointed head - MP6)	1380.Ø.15F (Ø32 - Ø100)	1320.Ø.25F (Ø32 - Ø100)
14	Square angle trunnion (AB7)	1380.Ø.35F (Ø32 - Ø100)	1320.Ø.23F (Ø32 - Ø100)
15	Square angle trunnion (with jointed head)		1320.Ø.27F (Ø32 - Ø100)
16	Square angle trunnion (not specified by ISO 15552)	1380.Ø.11F (Ø32 - Ø100)	/
17	Standard trunnion (with jointed head)	1380.Ø.36F (Ø32 - Ø100)	1320.Ø.26F (Ø32 - Ø100)
18	Standard trunnion (not specified by ISO 15552)	1380.Ø.10F (Ø32 - Ø100)	/
19	Complete standard trunnion	/	1320.Ø.22F (Ø32 - Ø100)



### Rod lock nut

Ordering code	
Ø20-Ø25:	<b>1200.20.32F</b>
Ø32-Ø40:	<b>1320.32.32F</b>
Ø50-Ø63:	<b>1320.40.32F</b>
Ø80-Ø100:	<b>1320.50.32F</b>

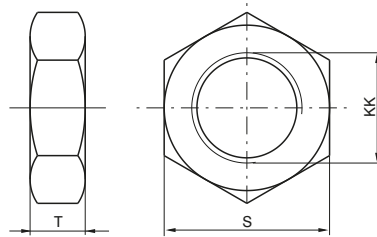

Bore	Ø20	Ø25	Ø32	Ø40	Ø50	Ø63	Ø80	Ø100
S	13	13	17	17	19	19	24	24
T	5	5	6	6	7	7	8	8
KK	M8x1.25	M8x1.25	M10x1.25	M10x1.25	M12x1.25	M12x1.25	M16x1.5	M16x1.5
Weight g	12	12	15	15	20	20	20	20

### Ball joint

Ordering code	
Ø20-Ø25:	<b>1200.20.32F</b>
Ø32-Ø40:	<b>1320.32.32F</b>
Ø50-Ø63:	<b>1320.40.32F</b>
Ø80-Ø100:	<b>1320.50.32F</b>

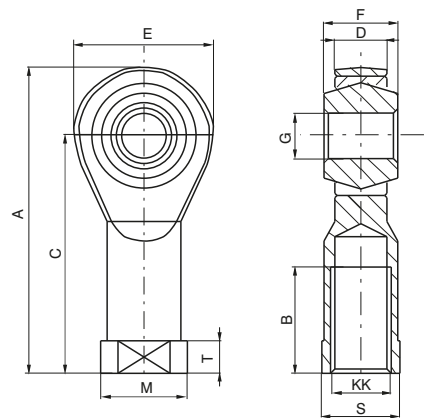

Bore	Ø20	Ø25	Ø32	Ø40	Ø50	Ø63	Ø80	Ø100
A	48	48	57	57	66	66	85	85
B	16	16	20	20	22	22	28	28
C	36	36	43	43	50	50	64	64
D (-0,1)	9	9	10,5	10,5	12	12	15	15
E	24	24	28	28	32	32	42	42
F	12	12	14	14	16	16	21	21
G (H7)	8	8	10	10	12	12	16	16
KK	M8x1,25	M8x1,25	M10x1,25	M10x1,25	M12x1,25	M12x1,25	M16x1,5	M16x1,5
M	16	16	19	19	22	22	27	27
S	14	14	17	17	19	19	22	22
T	5	5	6,5	6,5	6,5	6,5	8	8
Weight g	46	46	76	76	110	110	220	220

### Fork

Ordering code	
Ø20-Ø25:	<b>1200.20.04</b>
Ø32-Ø40:	<b>1320.32.13F</b>
Ø50-Ø63:	<b>1320.40.13F</b>
Ø80-Ø100:	<b>1320.50.13F</b>

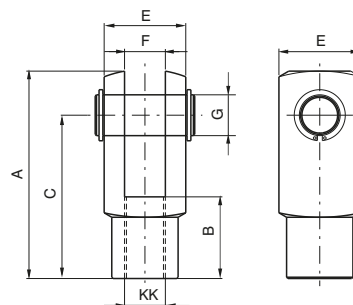

Bore	Ø20	Ø25	Ø32	Ø40	Ø50	Ø63	Ø80	Ø100
A	42	42	52	52	62	62	83	83
B	16	16	20	20	24	24	32	32
C	32	32	40	40	48	48	64	64
E	16	16	20	20	24	24	32	32
F (B12)	8	8	10	10	12	12	16	16
G	8	8	10	10	12	12	16	16
KK	M8x1,25	M8x1,25	M10x1,25	M10x1,25	M12x1,25	M12x1,25	M16x1,5	M16x1,5
Weight g	45	45	100	100	140	140	340	340

### Fork with clips

Ordering code

Ø20-Ø25: **1200.20.04/1**  
 Ø32-Ø40: **1320.32.13/1F**  
 Ø50-Ø63: **1320.40.13/1F**  
 Ø80-Ø100: **1320.50.13/1F**

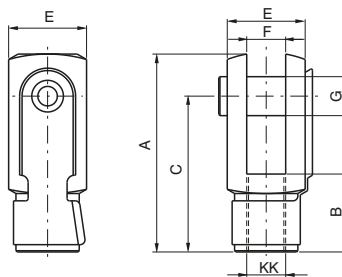

Bore	Ø20	Ø25	Ø32	Ø40	Ø50	Ø63	Ø80	Ø100
A	42	42	52	52	62	62	83	83
B	16	16	20	20	24	24	32	32
C	32	32	40	40	48	48	64	64
E	16	16	20	20	24	24	32	32
F (B12)	8	8	10	10	12	12	16	16
G	8	8	10	10	12	12	16	16
KK	M8x1,25	M8x1,25	M10x1,25	M10x1,25	M12x1,25	M12x1,25	M16x1,5	M16x1,5
Weight g	45	45	100	100	140	140	340	340

### Self-aligning joint

Ordering code

Ø20-Ø25: **1200.20.33F**  
 Ø32-Ø40: **1320.32.33F**  
 Ø50-Ø63: **1320.40.33F**  
 Ø80-Ø100: **1320.50.33F**

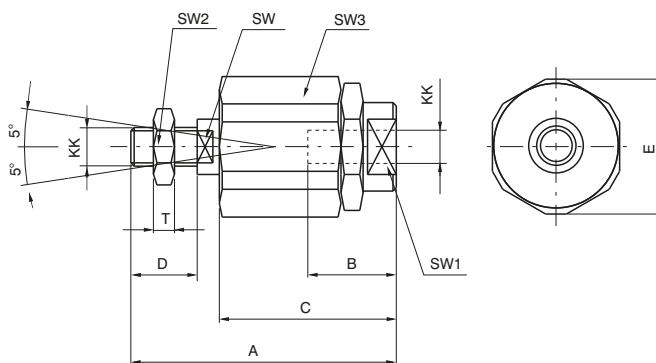

Bore	Ø20	Ø25	Ø32	Ø40	Ø50	Ø63	Ø80	Ø100
A	57	57	71	71	75	75	103	103
B	20	20	20	20	20	20	32	32
C	33	33	46	46	46	46	63	63
D	20	20	20	20	24	24	32	32
E	19	19	32	32	32	32	45	45
KK	M8x1,25	M8x1,25	M10x1,25	M10x1,25	M12x1,25	M12x1,25	M16x1,5	M16x1,5
SW	7	7	12	12	12	12	20	20
SW1	11	11	19	19	19	19	27	27
SW2	13	13	17	17	19	19	24	24
SW3	17	17	30	30	30	30	41	41
T	5	5	6	6	7	7	8	8
Weight g	60	60	220	220	230	230	660	660

### Valves direct mounting nut

Ordering code

**1500.20.F**

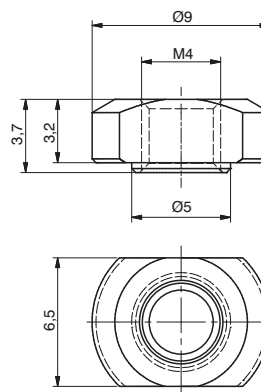
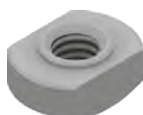

### Flange (MF2)

Ordering code
Ø20-Ø25: <b>1540.Ø.03F</b>
Ø32-Ø100: <b>1380.Ø.03F</b>

The kit comprises:  
n°1 flange (plated zinc steel)  
n°4 screws (plated zinc steel)

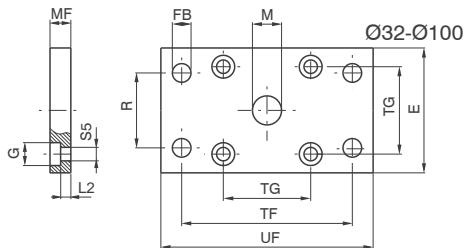
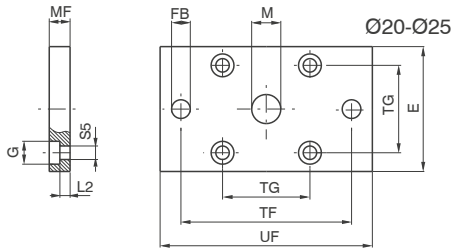
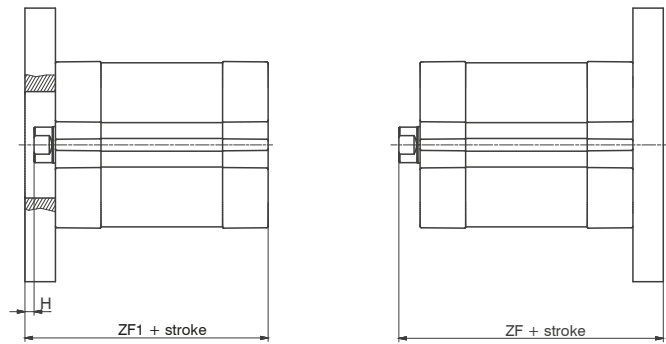

Bore	Ø20	Ø25	Ø32	Ø40	Ø50	Ø63	Ø80	Ø100
E	35	40	45	52	65	75	95	115
FB (H 13)	6.6	6.6	7	9	9	9	12	14
G	9.5	9.5	10.5	10.5	15	15	18	18
M (H 11)	16	16	30	35	40	45	45	55
MF (JS 14)	8	8	10	10	12	12	16	16
R (JS 14)	/	/	32	36	45	50	63	75
TF (JS 14)	55	60	64	72	90	100	126	150
TG	22	26	32.5	38	46.5	56.5	72	89
UF	70	75	80	90	110	120	150	170
ZF	51	53	130	145	155	170	190	205
ZF1	45	47	54	55	57	61	70	83
H	2	2	3	3	4	4	6	6
L2	3	3	5	5	6.5	6.5	8	8
S5	5.5	5.5	6.6	6.6	9	9	11	11
Weight g	125	160	190	250	480	620	1430	1990

### Foot (MS1)

Ordering code
<b>1540.Ø.05/1F</b>

The kit comprises:  
n°1 foot (plated zinc steel)  
n°2 screws (plated zinc steel)

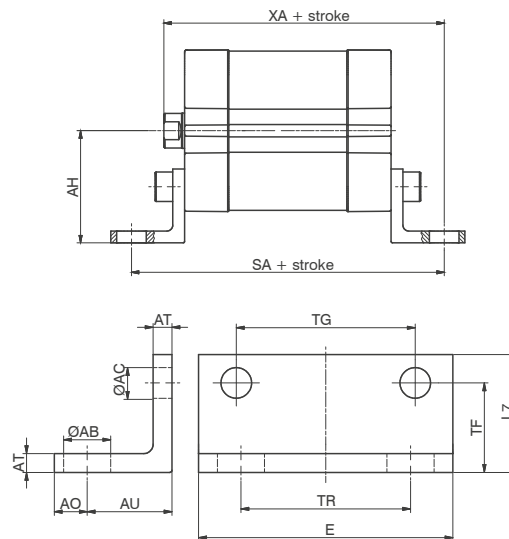

Bore	Ø20	Ø25	Ø32	Ø40	Ø50	Ø63	Ø80	Ø100
AB (H 14)	7	7	7	10	10	10	12	14.5
AC	5.5	5.5	6.5	6.5	8.5	8.5	10.5	10.5
AH	27	29	33.5	38	45	50	63	74
AO (max)	7	7	7	7	9	9	11	13
AT (±0.5)	4	4	4	4	5	5	6	6
AU (±0.2)	16	16	16	18	21	21	26	27
E (max)	35.5	39.5	46.5	54	65	77	95	115
L7	20	20	25	25	30	30	40	45
TF (±0.1)	16	16	17.25	19	21.75	21.75	27	29.5
TG (±0.2)	22	26	32.5	38	46.5	56.5	72	89
TR (JS 14)	22	26	32	36	45	50	63	75
SA	69	71	76	81	87	91	106	121
XA	59	61	67	70	74	78	90	104
Weight g	40	45	60	70	130	160	300	405

### Rear female clevis (MP2)

Ordering code

Aluminium: **1380.Ø.09F**  
Steel: **1320.Ø.20F**

The kit comprises:  
n°1 clevis (steel or painted aluminium)  
n°4 screws (plated zinc steel)  
n°1 pin (plated zinc steel)  
n°2 circlips (steel)

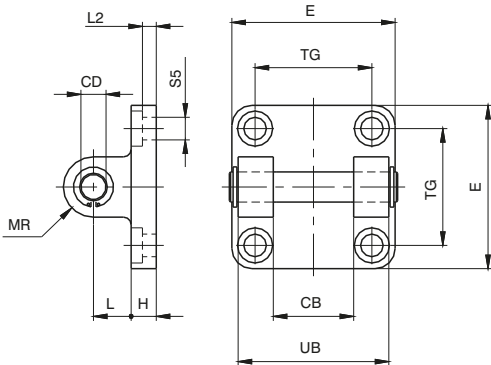
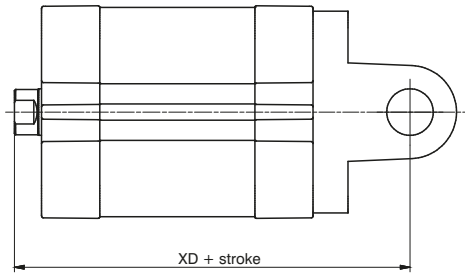

Bore		Ø32	Ø40	Ø50	Ø63	Ø80	Ø100
CB (H 14)		26	28	32	40	50	60
CD		10	12	12	16	16	20
E	Aluminium	45	52	65	75	95	115
	Steel	45	55	65	75	95	115
H	Aluminium	9	9	11	11	14	14
	Steel	10	10	10	12	14	16
L	Aluminium	13	16	16	21	22	27
	Steel	12	15	17	20	22	25
MR		10	12	12	16	16	20
TG		32.5	38	46.5	56.5	72	89
UB (h14)		45	52	60	70	90	110
XD		73	77	80	83	100	118
L2(±0.5)		5.5	5.5	6.5	6.5	10	10
S5		6.6	6.6	9	9	11	11
Weight	Aluminium	80	130	185	310	530	910
	Steel	180	290	400	670	1160	2000

### Narrow rear female trunnion (AB6)

Ordering code

Aluminium: **1380.Ø.30F**  
Steel: **1320.Ø.29F**

The kit comprises:  
n°1 clevis (plated zinc steel or painted)  
n°4 screws (plated zinc steel)  
n°1 pin (plated zinc steel) complete with elastic pin and ring

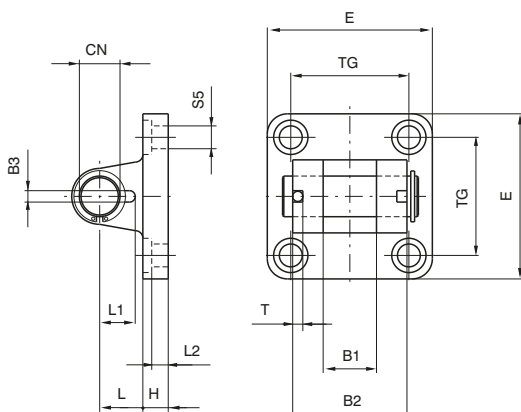
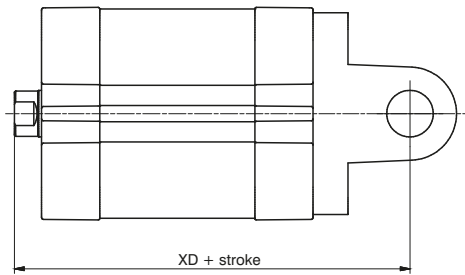

Bore		Ø32	Ø40	Ø50	Ø63	Ø80	Ø100
B1 (H 14)		14	16	21	21	25	25
B2 (d 12)		34	40	45	51	65	75
B3 (±0.2)		3.3	4.3	4.3	4.3	4.3	6.3
CN		10	12	16	16	20	20
E	Aluminium	45	52	65	75	95	115
	Steel	45	55	65	75	95	115
H	Aluminium	9	9	11	11	14	14
	Steel	10	10	10	12	14	16
L	Aluminium	13	16	16	21	22	27
	Steel	12	15	17	20	22	25
L1		11.5	12	14	14	16	16
L2 (±0.5)		5.5	5.5	6.5	6.5	10	10
S5		6.6	6.6	9	9	11	11
T		3	4	4	4	4	4
TG		32.5	38	46.5	56.5	72	89
XD		73	77	80	89	100	118
Weight	Aluminium	70	115	200	290	570	820
	Steel	160	270	370	670	1110	2100

### Rear male clevis (MP4)

Ordering code	
Aluminium: Ø20-Ø25:	<b>1580.Ø.09/1F</b>
Ø32-Ø100:	<b>1380.Ø.09/1F</b>
Steel: Ø20-Ø25:	<b>1580.Ø.09/2F</b>
Ø32-Ø100:	<b>1320.Ø.21F</b>

The kit comprises:  
 n°1 clevis (steel or painted aluminium)  
 n°4 screws (plated zinc steel)  
 n°1 pin (plated zinc steel) ★  
 n°2 circlips (steel)  
 ★ (from Ø32)

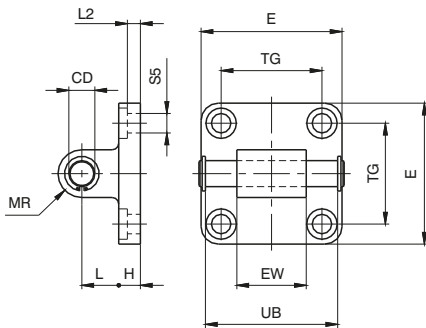
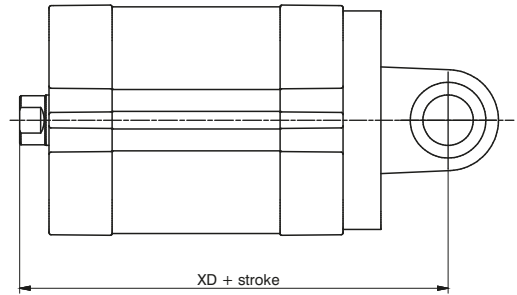

Bore		Ø20	Ø25	Ø32	Ø40	Ø50	Ø63	Ø80	Ø100
CD		8(H9)	8(H9)	10	12	12	16	16	20
E	Aluminium	34	38	45	52	65	75	95	115
	Steel	34	38	45	55	65	75	95	115
EW		16(h14)	16(h14)	26 <sup>(-0.2/-0.6)</sup>	28 <sup>(-0.2/-0.6)</sup>	32 <sup>(-0.2/-0.6)</sup>	40 <sup>(-0.2/-0.6)</sup>	50 <sup>(-0.2/-0.6)</sup>	60 <sup>(-0.2/-0.6)</sup>
H	Aluminium	6	6	9	9	11	11	14	14
	Steel	/	/	10	10	10	12	14	16
L	Aluminium	14	14	13	16	16	21	22	27
	Steel	/	/	12	15	17	20	22	25
MR		8	8	10	12	12	16	16	20
TG		22	26	32,5	38	46,5	56,5	72	89
UB <sup>(+0.5)</sup>		/	/	46	53	61	71	91	111
XD		63	65	73	77	80	89	100	118
L2 (±0.5)		2,6	2,6	5,5	5,5	6,5	6,5	10	10
S5		5,5	5,5	6,6	6,6	9	9	11	11
Weight g	Aluminium	25	28	90	130	190	340	580	960
	Steel	70	80	210	330	430	810	1350	2400

### Rear male clevis (with jointed head MP6)

Ordering code	
Aluminium:	<b>1380.Ø.15F</b>
Steel:	<b>1320.Ø.25F</b>

The kit comprises:  
 n°1 clevis (steel or painted aluminium)  
 n°4 screws (plated zinc steel)

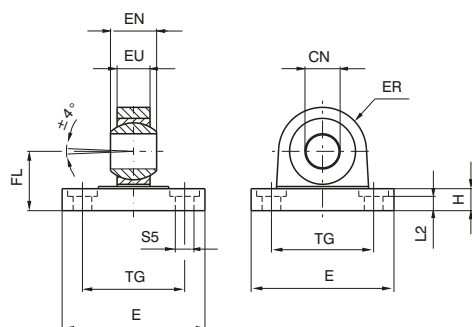
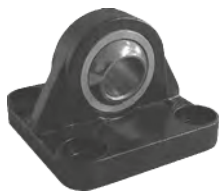
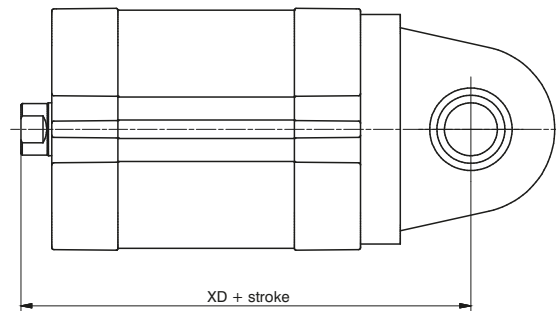

Bore		Ø32	Ø40	Ø50	Ø63	Ø80	Ø100
CN (H 7)		10	12	16	16	20	20
E	Aluminium	45	52	65	75	95	115
	Steel	45	55	65	75	95	115
EN (-0.1)		14	16	21	21	25	25
ER	Aluminium	16	19	21	24	28.5	30
	Steel	15	18	20	23	27	30
EU		10.5	12	15	15	18	18
FL (JS 15)		22	25	27	32	36	41
H	Aluminium	9	9	11	11	14	14
	Steel	10	10	10	12	14	16
L2 (±0.5)		5.5	5.5	6.5	6.5	10	10
S5		6.6	6.6	9	9	11	11
TG		32.5	38	46.5	56.5	72	89
XD		73	77	80	89	100	118
Weight g	Aluminium	60	100	180	245	480	650
	Steel	210	310	400	710	1350	2400

### Square angle trunnion (AB7)

Ordering code

Aluminium: **1380.Ø.35F**

Steel: **1320.Ø.23F**

The kit comprises:  
n°1 clevis (steel or painted aluminium)  
n°1 counter clevis, square (steel or painted aluminium)  
n°4 screws (plated zinc steel)  
n°1 pin (plated zinc steel)  
n°2 circlips (steel)

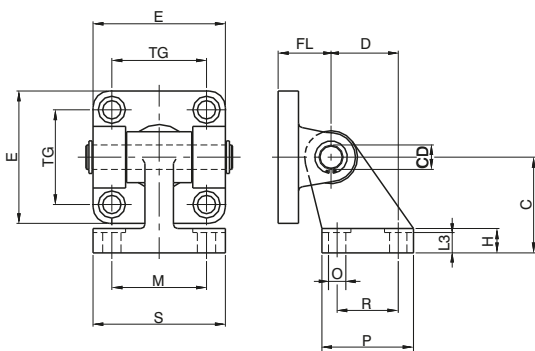
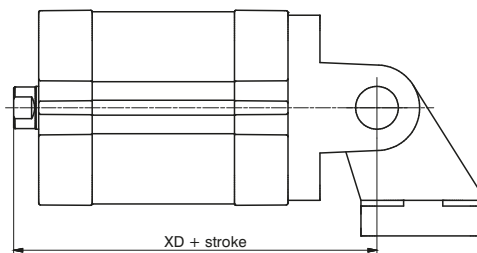

Bore		Ø32	Ø40	Ø50	Ø63	Ø80	Ø100
E	Aluminium	45	52	65	75	95	115
	Steel	45	55	65	75	95	115
TG		32.5	38	46.5	56.5	72	89
FL		22	25	27	32	36	41
D (JS14)		21	24	33	37	47	55
CD		10	12	12	16	16	20
C (JS15)		32	36	45	50	63	71
H	Aluminium	8	10	12	14	14	17
	Steel	8	10	12	12	14	15
L3	Aluminium	6.4	8.4	10.4	12.4	11.5	14.5
	Steel	6.5	8.5	10.5	10.5	11.5	12.5
R (JS14)		18	22	30	35	40	50
P		31	35	45	50	60	70
O (H13)		6.6	6.6	9	9	11	11
S		51	54	65	67	86	96
M (JS14)		38	41	50	52	66	76
XD		73	77	80	89	100	118
Weight g	Aluminium	120	180	225	435	730	1220
	Steel	340	500	640	1250	2100	3500

### Square angle trunnion (with joined head)

Ordering code

Steel: **1320.Ø.27F**

The kit comprises:  
n°1 clevis (painted steel)  
n°1 counter clevis square with joined head (painted steel)  
n°4 screws (plated zinc steel)  
n°1 pin (plated zinc steel)  
n°2 circlips (steel)

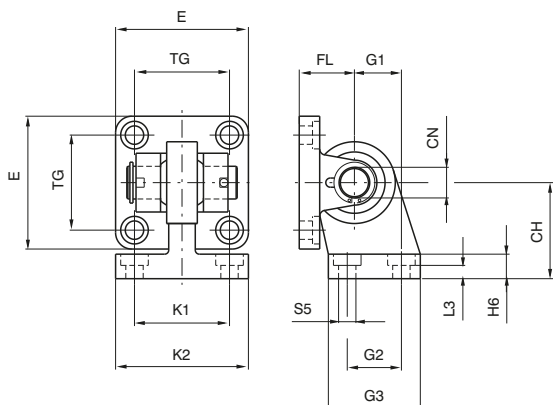
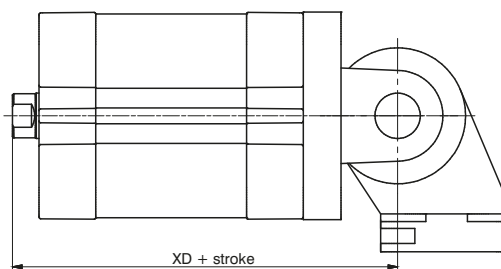

Bore		Ø32	Ø40	Ø50	Ø63	Ø80	Ø100
CH (JS 15)		32	36	45	50	63	71
CN		10	12	16	16	20	20
E		45	55	65	75	95	115
FL (JS 15)		22	25	27	32	36	41
G1 (JS 15)		21	24	33	37	47	55
G2 (JS 14)		18	22	30	35	40	50
G3		31	35	45	50	60	70
H6		10	10	12	12	14	15
K1 (JS 14)		38	41	50	52	66	76
K2		51	54	65	67	86	96
L3 (+0°)		8,5	8,5	10,5	10,5	11,5	12,5
S5		6,6	6,6	9	9	11	11
TG		32,5	38	46,5	56,5	72	89
XD		73	77	80	89	100	118
Weight g		330	480	830	1220	2100	3580

PNEUMATIC ACTUATION

► Square angle trunnion (not specified by ISO-VDMA standard)

Ordering code  
Aluminium: **1380.Ø.11F**

The kit comprises:  
n°1 clevis (painted aluminium)  
n°1 counter clevis square (painted aluminium)  
n°4 screws (plated zinc steel)  
n°1 pin (plated zinc steel)  
n°2 circlips (steel)

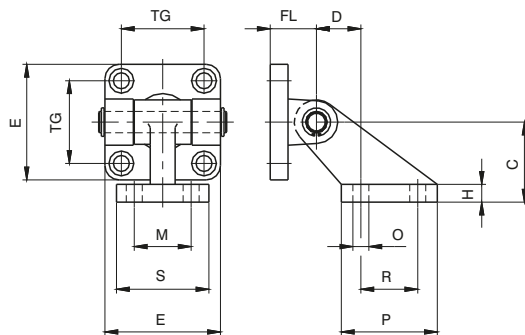
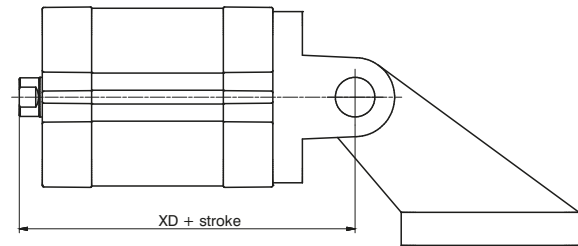

Bore	Ø32	Ø40	Ø50	Ø63	Ø80	Ø100
C (±0,2)	32	45	45	63	63	90
D (±0,5)	18	25	25	32	32	40
E	45	52	65	75	95	115
H	8	10	10	12	12	17
FL	22	25	27	32	36	41
M (JS 14)	25	32	32	40	40	50
TG	32,5	38	46,5	56,5	72	89
O (H 13)	7	9	9	11	11	14
P	37	54	54	75	75	103
R (JS 14)	20	32	32	50	50	70
S	41	52	52	63	63	80
XD	73	77	80	89	100	118
Weight g	130	260	330	600	820	1560

► Square angle trunnion (with joined head)

Ordering code  
Aluminium: **1380.Ø.36F**  
Steel: **1320.Ø.26F**

The kit comprises :  
n°1 clevis (steel or painted aluminium)  
n°1 counter clevis with joined head (steel or painted aluminium)  
n°4 screws (plated zinc steel)  
n°1 pin (plated zinc steel) complete with elastic pin and ring

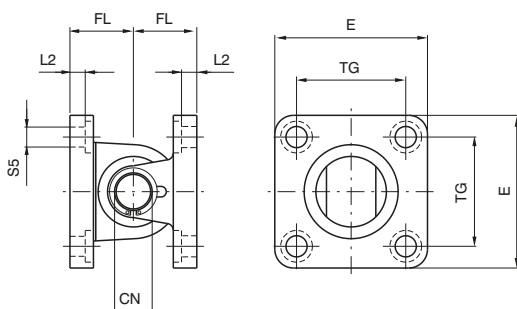
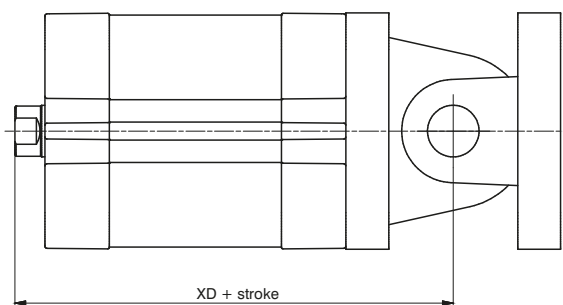

Bore	Ø32	Ø40	Ø50	Ø63	Ø80	Ø100
CN	10	12	16	16	20	20
E	Aluminium	45	52	65	75	95
	Steel	45	55	65	75	95
FL (JS 15)	22	25	27	32	36	41
L2 (±0.5)	5.5	5.5	6.5	6.5	10	10
S5	6.6	6.6	9	9	11	11
TG	32.5	38	46.5	56.5	72	89
XD	73	77	80	89	100	118
Weight g	Aluminium	130	215	380	535	1050
	Steel	380	580	770	1380	2460

**Standard trunnion (not specified by ISO-VDMA standard)**

Ordering code  
**Aluminium: 1380.Ø.10F**

The kit comprises:  
n°1 clevis (painted aluminium)  
n°1 counter clevis (painted aluminium)  
n°4 screws (plated zinc steel)  
n°1 pin (plated zinc steel)  
n°2 circlips (steel)

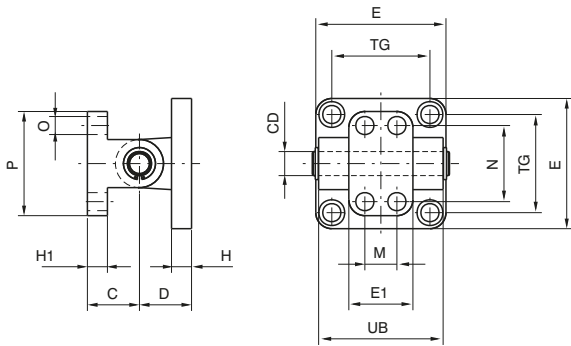
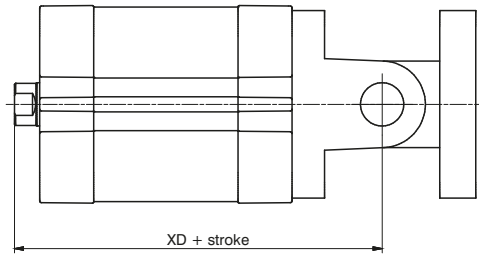

Bore	Ø32	Ø40	Ø50	Ø63	Ø80	Ø100
C (±0,2)	18	26	26	34	34	41
CD	10	12	12	16	16	20
D	22	25	27	32	36	41
E	45	52	65	75	95	115
E1	25	32	32	46	46	56
H	10	10	12	12	16	16
H1	8	10	10	12	12	16
M (±0,2)	-	16	16	25	25	32
N (±0,2)	28	38	38	54	54	90
O	7	9	9	11	11	14
P	40	52	52	75	75	115
TG	32,5	38	46,5	56,5	72	89
UB	45	52	60	70	90	110
XD	73	77	80	89	100	118
Weight g	110	190	240	490	710	1290

**Complete standard trunnion**

Ordering code  
**Steel: 1320.Ø.22F**

The kit comprises:  
n°1 clevis (painted steel)  
n°1 counter clevis (painted steel)  
n°4 screws (plated zinc steel)  
n°1 pin (plated zinc steel)  
n°2 circlips (steel)

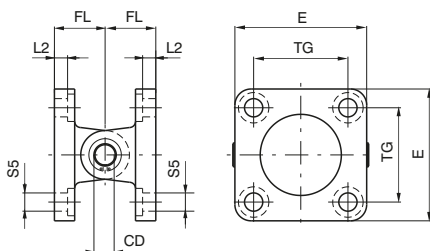
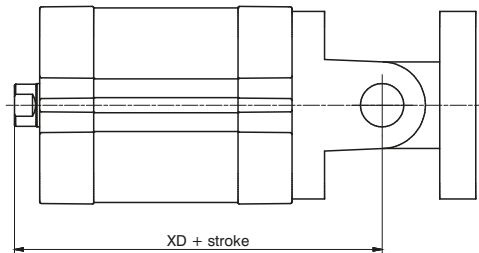

Bore	Ø32	Ø40	Ø50	Ø63	Ø80	Ø100
CD	10	12	12	16	16	20
E	45	55	65	75	95	115
FL	22	25	27	32	36	41
L 2 (±0.5)	5,5	5,5	6,5	6,5	10	10
S 5	6,6	6,6	9	9	11	11
TG	32,5	38	46,5	56,5	72	89
XD	73	77	80	89	100	118
Weight g	360	580	780	1370	2370	4110



### Alternative fixing options

**Frontal mounting:**

- from  $\text{Ø}20$  to  $\text{Ø}40$  bolt head
- the use of non-magnetic screws is recommended

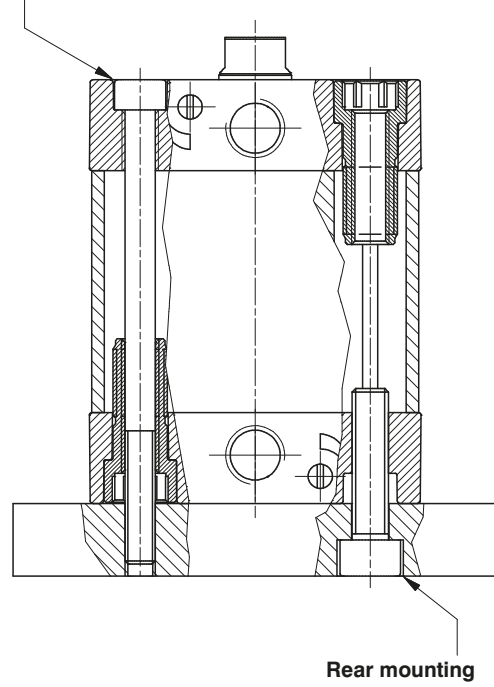

Admissible maximum radial load diagram

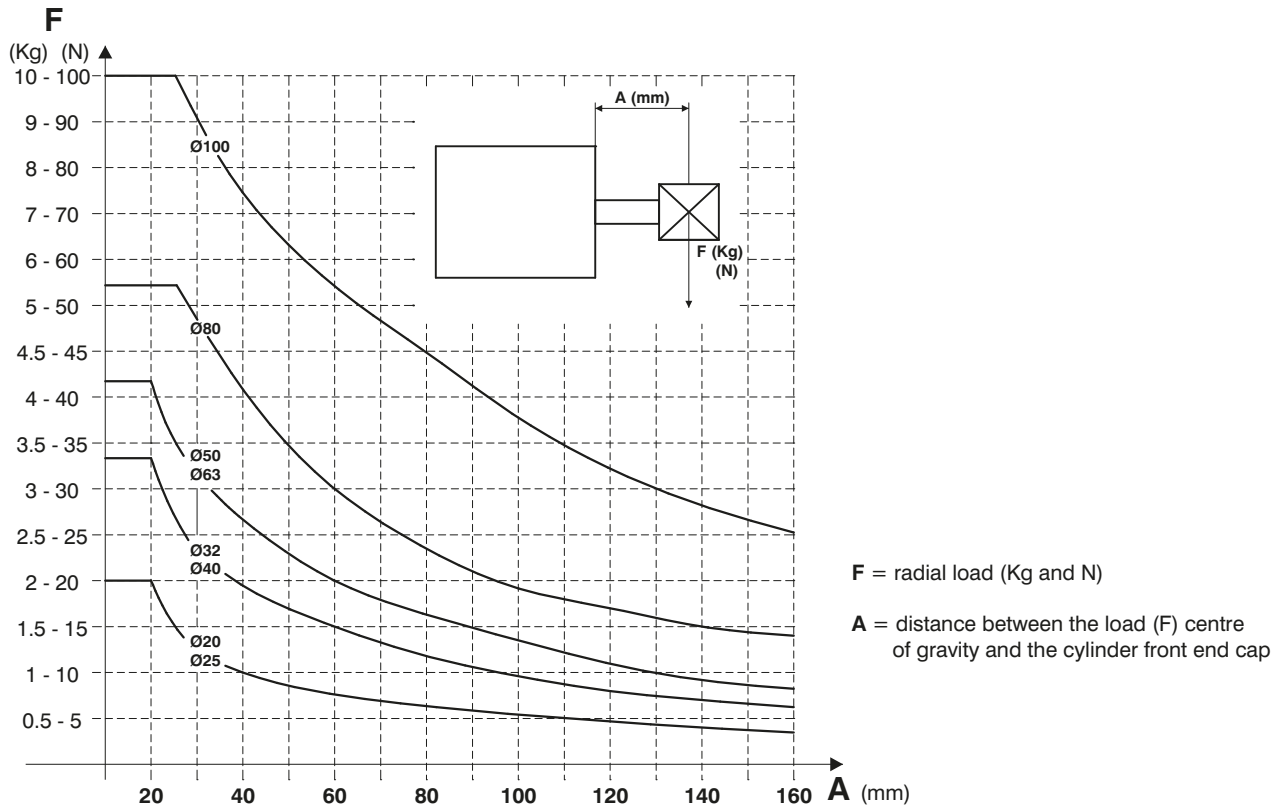

The diagram shows the maximum Radial load  $F$  (in Newtons) that can be applied to the cylinder piston rod as a function of the distance  $A$  (in mm); based upon the standard version cylinder under static conditions

End of stroke cushioning capacity diagram

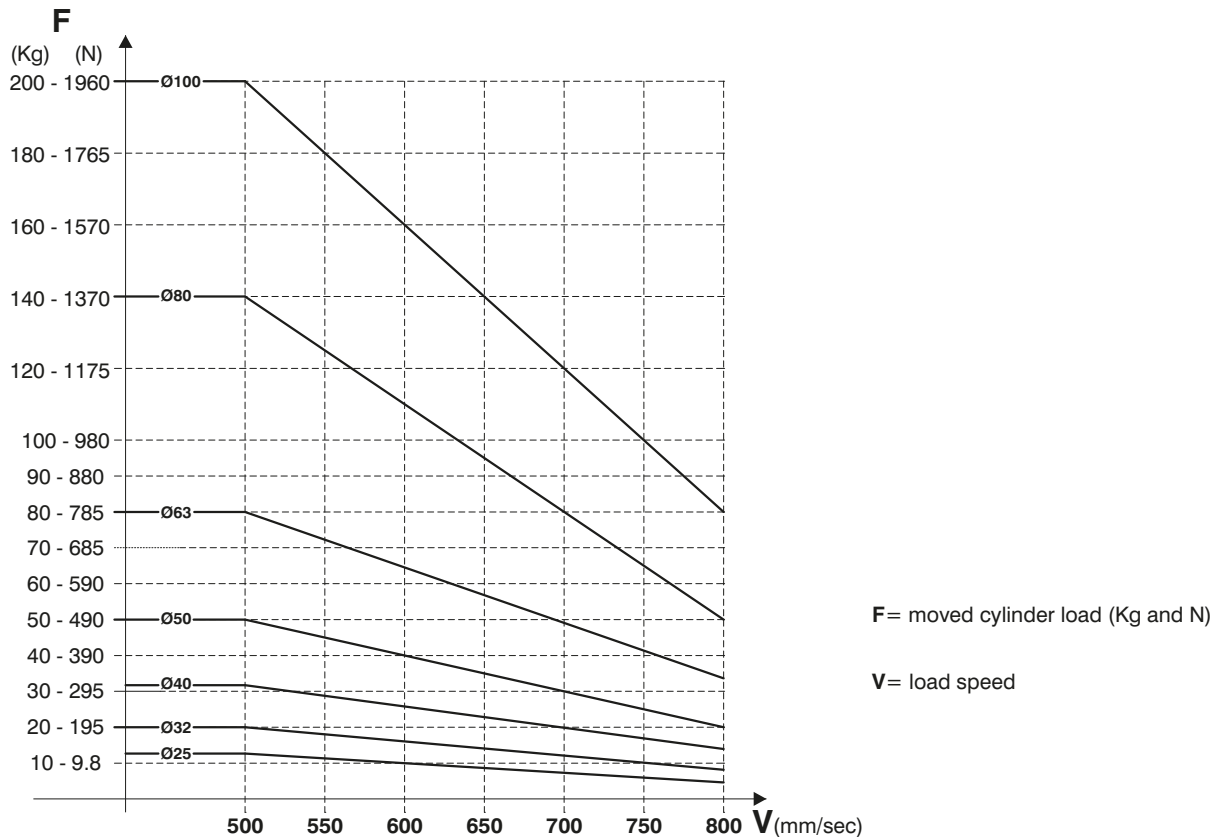

The diagram shows, for each diameter, the safety curves relative to the maximum loads which can be moved by the cylinder in function of its speed  $V$ . The data has been calculated under the following test conditions: Cylinder mounted vertically with the rod pointing down, air pressure at 5 bar and with a guided load. Important: Do not exceed the recommended values in the table as reduced life or damage to the cylinder may result.



## Series 1200, Special performance microbore cylinders

### General

These microbore cylinders are not subject to a standard; they are single acting with a front spring, can be either hexagonal or round bodied and either completely threaded or threaded with a plain rod ending. They are available with M5 connections or with incorporated quick fittings.

### Construction characteristics

Body	nickel-plated brass
Rod / piston	stainless steel (C43 chromed)
Rod bushing	brass
Spring	stainless steel
Seal	NBR

### Technical characteristics

Fluid	Filtered air. No lubrication needed, if applied it shall be continuous.
Pressure	min. 3 bar - max. 7 bar
Temperature	min. -5°C - max. +70°C

"Attention: Dry air must be used for application below 0°C"

**Threaded body, round execution**

Ordering code	Bore	Stroke	A	B	C	D	T
<b>1213.6.5</b>	6	5	M10x1	3	5	30,5	4/2
<b>1213.6.10</b>	6	10	M10x1	3	5	35,5	4/2
<b>1213.6.20</b>	6	20	M10x1	3	5	49,5	4/2
<b>1213.8.5</b>	8	5	M12x1	3	6	28	4/2
<b>1213.10.3</b>	10	3	M15x1,5	5	1	44	4/2
<b>1213.10.5</b>	10	5	M15x1,5	5	5	40	4/2
<b>1213.10.10</b>	10	10	M15x1,5	5	12	44	4/2

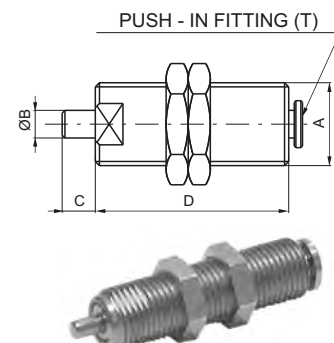

**Threaded body, hexagonal execution**

Ordering code	Description
<b>1213.Ø.stroke.C</b>	Single acting front spring
<b>1213.Ø.stroke.CF</b>	Single acting front spring threaded rod

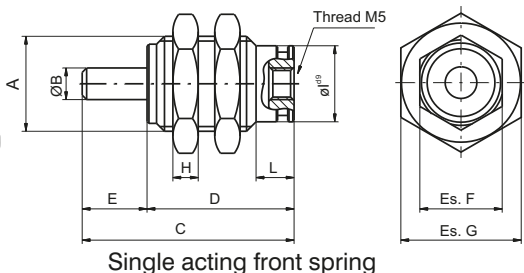

Single acting front spring

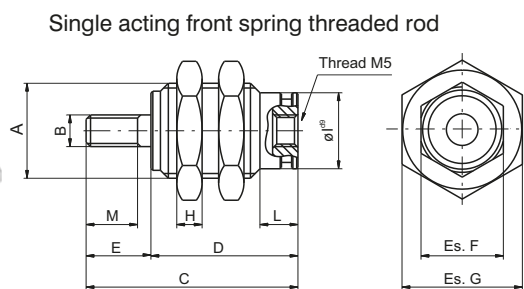

Single acting front spring threaded rod

Ø Cil.	Stroke	A	ØB	B	C	D	E	Es. F	Es. G	H	ØI	L	M
6	5	M10x1	Ø3	M3x0.5	27,5	18,5	9	9	12	3	Ø8,5	6	7
6	10	M10x1	Ø3	M3x0.5	34,5	25,5	9	9	12	3	Ø8,5	6	7
6	15	M10x1	Ø3	M3x0.5	41,5	32,5	9	9	12	3	Ø8,5	6	7
10	5	M15x1.5	Ø5	M4x0.7	32,5	20,5	12	13	19	4	Ø12	6	10
10	10	M15x1.5	Ø5	M4x0.7	39	27	12	13	19	4	Ø12	6	10
10	15	M15x1.5	Ø5	M4x0.7	46	34	12	13	19	4	Ø12	6	10
16	5	M22x1.5	Ø6	M5x0.8	37,5	23,5	14	20	27	5	Ø19	7	12
16	10	M22x1.5	Ø6	M5x0.8	43,5	29,5	14	20	27	5	Ø19	7	12
16	15	M22x1.5	Ø6	M5x0.8	50	36	14	20	27	5	Ø19	7	12

**Front fixing microbore cylinders**

Ordering code
<b>1273.4.10</b>

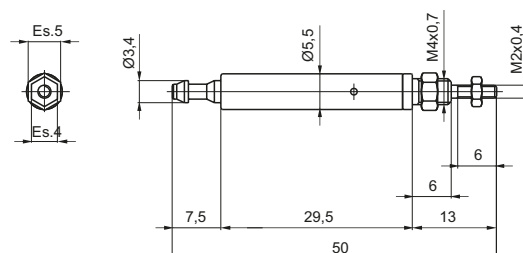

## Series 1325-1326-1345-1347, twin rod cylinders

### Construction characteristics

Front end cap	anodised aluminium
Rear end cap	UNI 5079 aluminium alloy casting
Rod	C43 chromed steel stainless steel
Barrel	RA=0.3-0.5 anodised aluminium
Cushion bushings	hard aluminium
Piston	vulcanized rubber block on steel core with incorporated permanent magnet, or without magnet for non magnetic version (plus spacer).
Flange	zinc plated steel
Rod seal	PUR
Other seals	NBR 80 shore rubber
Cushioning adjustment screw	nickel-plated steel

### Operational characteristics

Fluid	Filtered air. No lubrication needed, if applied it shall be continuous.
Max. pressure	10 bar
Working temperature	-5°C - +70°C

Please follow the suggestions below to ensure a long life for these cylinders:

- use clean and lubricated air
- correct alignment during assembly with regard to the applied load so as to avoid radial components or bending the rod.
- avoid high speeds together with long strokes and heavy loads: this would produce kinetic energy which the cylinder cannot absorb, especially if used as a limit stop (in this case use mechanical stop device)
- evaluate the environmental characteristics of cylinder used (high temperature, hard atmosphere, dust, humidity etc.)

**Please note: air must be dried for applications with lower temperature.**

Use hydraulic oils H class (ISO VG32) for correct continued lubrication.  
Our Technical Department will be glad to help.

### Cushioning lengths

Bore	Ø	32	40	50	63	80	100
Front length	mm	22	22	24	32	32	32
Rear length	mm	28	32	32	40	44	50

### Standard strokes

- Ø32 25 - 50 - 75 - 100 - 150 - 200 mm
- Ø40 25 - 50 - 75 - 100 - 150 - 200 - 250 mm
- Ø50 25 - 50 - 75 - 100 - 150 - 200 - 250 - 300 mm
- Ø63 25 - 50 - 75 - 100 - 150 - 200 - 250 - 300 - 350 mm
- Ø80 25 - 50 - 75 - 100 - 150 - 200 - 250 - 300 - 350 - 400 - 500 mm
- Ø100 25 - 50 - 75 - 100 - 150 - 200 - 250 - 300 - 350 - 400 - 500 mm

On request are available strokes up to 1000 mm

### Stroke tolerance (ISO 15552)

Bore	Stroke	Tolerance
32 - 40 - 50	up to 500 mm	+2
63 - 80 - 100		0

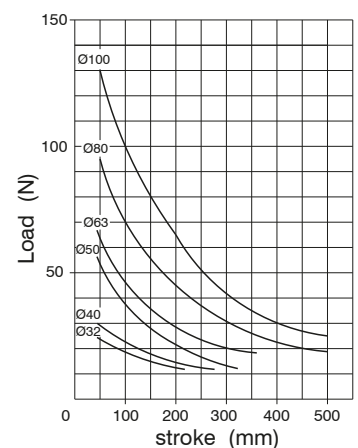
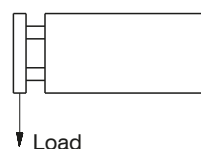

**Basic version**

Ordering code

- 1325.Ø.stroke.01 magnetic
- 1326.Ø.stroke.01 non magnetic
- 1325.Ø.stroke.01X magnetic stainless steel rod
- 1326.Ø.stroke.01X non magnetic stainless steel rod

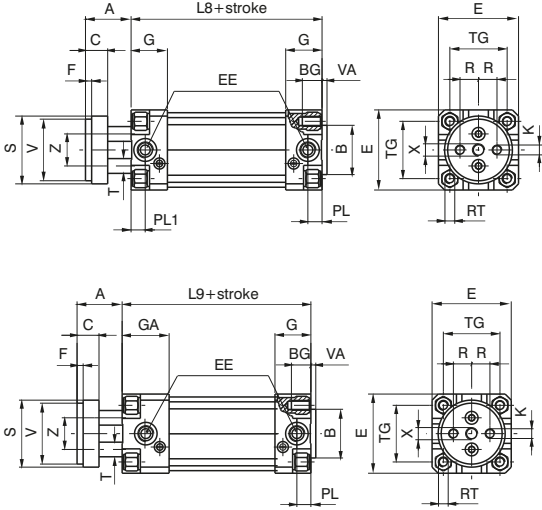

Bore	32	40	50	63	80	100		
A	26	30	37	37	46	51		
AM	22	24	32	32	40	40		
B	30	35	40	45	45	55		
BG	12	12	16	16	20	20		
C	15	15	18	22	22	22		
E	46	52	65	75	95	115		
EE	G 1/8"	G 1/4"	G 1/4"	G 3/8"	G 3/8"	G 1/2"		
F	4	4	5	5	5	5		
G	25	29	29,5	36	36	40		
GA	50	54	54,5	61	61	65		
K	M6	M8	M8	M10	M12	M12		
L8	94	105	106	121	128	138		
L9	119	130	131	146	153	163		
PL	9	11,5	13	14	16	18		
PL1	9,5	11	10,5	14	13	15		
R	9,5	11,25	15	19	25	35		
RT	M6	M6	M8	M8	M10	M10		
S	35	45	55	70	85	105		
T	8	10	12	16	20	20		
TG	32,5	38	46,5	56,5	72	89		
V	32	40	50	63	80	100		
VA	4	4	4	4	4	4		
Z	18	22	26	35	40	50		
WH	26	30	37	37	46	51		
X	M8	M10	M10	M12	M14	M14		
Weight g	Stroke 0	Basic version	560	810	1380	2300	3680	5740
		Extended ver.	650	950	1500	2500	4100	6300
		every 10 mm	20	26	30	40	80	90

**Extended front cap**

- 1345.Ø.stroke.01 magnetic
- 1347.Ø.stroke.01 non magnetic
- 1345.Ø.stroke.01X magnetic stainless steel rod
- 1347.Ø.stroke.01X non magnetic stainless steel rod

**Through rod cylinder version with ISO standard**

Ordering code

- 1325.Ø.stroke.02 magnetic
- 1326.Ø.stroke.02 non magnetic

Rods options

- 1325.Ø.stroke.02X magnetic stainless steel rod
- 1326.Ø.stroke.02X non magnetic stainless steel rod

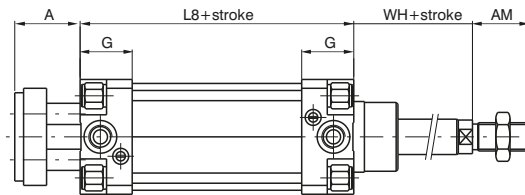

**Through rod twin cylinder version**

Ordering code

- 1325.Ø.stroke.06 magnetic
- 1326.Ø.stroke.06 non magnetic

Rods options

- 1325.Ø.stroke.06X magnetic stainless steel rod
- 1326.Ø.stroke.06X non magnetic stainless steel rod

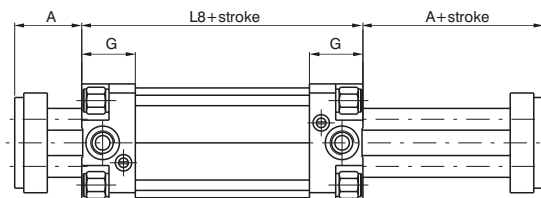

PNEUMATIC ACTUATION

### Magnetic sensors

For sensor and sensor support bracket please refer to the 1319 and 1320 series.

### Accessories

All of the attachments of the ISO 15552 can be mounted, with the exclusion of the front flange and the foot mounting bracket that, although they are part of the same series, need a small adjustment in the exit zone of the rods. For these there is a different code and the dimensions are indicated below.

### Threaded Nipple

Ordering code
<b>1325.Ø.17F</b>

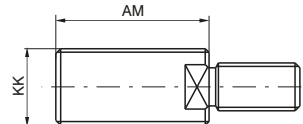

Bore	32	40	50	63	80	100
AM	22	24	32	35	40	40
KK	M10x1,25	M12x1,25	M16x1,5	M16x1,5	M20x1,5	M20x1,5
Weight g	17	27	63	65	110	110

### Front Flange

Ordering code
<b>1325.Ø.03F</b>

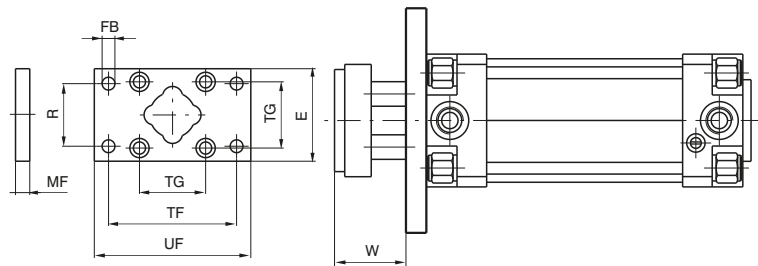

Bore	32	40	50	63	80	100
E	45	52	65	75	95	115
FB (H13)	7	9	9	9	12	14
MF (JS 14)	10	10	12	12	16	16
R (JS 14)	32	36	45	50	63	75
TF (JS 14)	64	72	90	100	126	150
TG	32,5	38	46,5	56,5	72	89
UF	80	90	110	120	150	170
W	16	20	25	25	30	35
Weight g	160	250	480	620	1430	3500

### Front foot mounting bracket (short)

Ordering code
<b>1325.Ø.05/1F</b> (1 piece)

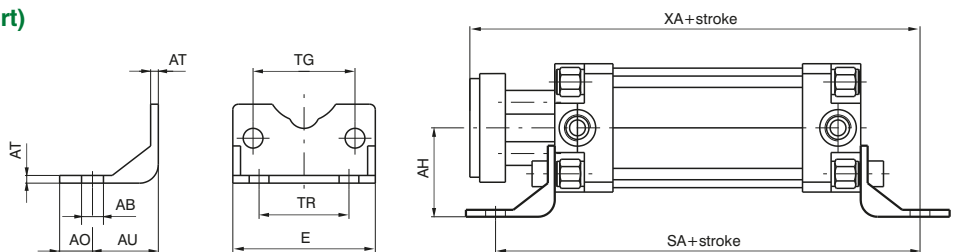

Bore	32	40	50	63	80	100
AB (H14)	7	9	9	9	12	14
AH (JS 15)	32	36	45	50	63	71
AO (± 0,2)	11	8	13	13	14	15
AT	3,5	3,5	3,5	4,5	5	5
AU	24	28	32	32	41	41
E	45	52	65	75	95	115
SA	142	161	170	185	210	220
TG	32,5	38	46,5	56,5	72	89
TR (JS 14)	32	36	45	50	63	75
XA	144	163	175	190	215	230
Weight g	50	70	120	180	320	400



## Series 1370 - 1371 - 1372 - 1373 - ECOFLAT

### General

Profiled tube has two "T" slots on the side hosting sensors 1580.\_, MRS.\_, MHS.\_. without adaptors.  
Two additional connections are also available on rear cover for cylinder feeding.

### Construction characteristics

End caps	aluminium anodised
Rod	C43 chromed steel or stainless steel
Barrel	aluminium alloy anodised
Piston	acetal resin, aluminium on request
Piston-seal	PUR
Rod-seal	PUR (FPM upon request)
Adjusting screw	zinc plated steel
Shock absorber	NBR

### Operational characteristics

Fluid	Filtered air. No lubrication needed, if applied it shall be continuous.
Max. pressure	10 bar
Operating temperature	-5°C - +70°C

Please follow the suggestions below to ensure a long life for these cylinders:

- use clean and lubricated air
- correct alignment during assembly with regard to the applied load so as to avoid radial components or bending the rod;
- avoid high speeds together with long strokes and heavy loads: this would produce kinetic energy which the cylinder cannot absorb, especially if used as a limit stop (in this case use mechanical stop device and aluminium piston);
- evaluate the environmental characteristics of cylinder used (high temperature, hard atmosphere, dust, humidity etc.)

**Please note: air must be dried for applications with lower temperature.**

Use hydraulic oils H class (ISO VG32) for correct continued lubrication.

Our Technical Department will be glad to help.

### Maximum standard strokes

Size 25	200 mm
Size 32 - 63	320 mm

### Sections (cm<sup>2</sup>)

Size	25	32	40	50	63
Out stroke (cm <sup>2</sup> )	5,28	8,09	13,09	20,28	32,68
In stroke (cm <sup>2</sup> )	4,49	6,96	11,08	17,14	29,54

In order to calculate the theoretical force generated by the unit, both outstroke and instroke, it is necessary to use the following equation

$$\text{FORCE(Kg)} = \text{Surface (cm}^2\text{)} \times \text{Pressure(bar)}$$

It is also necessary to remember that the theoretical force must be reduced by 10-15% in order to account for the unit internal friction.

### Maximum rod radial movement (°)

Size	25	32	40	50	63
Rod radial movement	±0.8	±0.7	±0.6	±0.5	±0.4

### Maximum torque applicable on the piston rod (Nm):

Size	25	32	40	50	63
Maximum torque	0.8	1	1,3	1,8	2,1

The maximum torque values must also be accounted for while mounting accessories on the piston rod.



► **Basic version “1” female rod**

Ordering code
<b>SIDE CONNECTION</b>
1370.size.stroke.1 Magnetic chrome plated rod
1371.size.stroke.1 Magnetic stainless steel rod
1372.size.stroke.1 Non magnetic chrome plated rod
1373.size.stroke.1 Non magnetic stainless steel rod
<b>REAR CONNECTION</b>
1370.size.stroke.1.P Magnetic chrome plated rod
1371.size.stroke.1.P Magnetic stainless steel rod
1372.size.stroke.1.P Non magnetic chrome plated rod
1373.size.stroke.1.P Non magnetic stainless steel rod

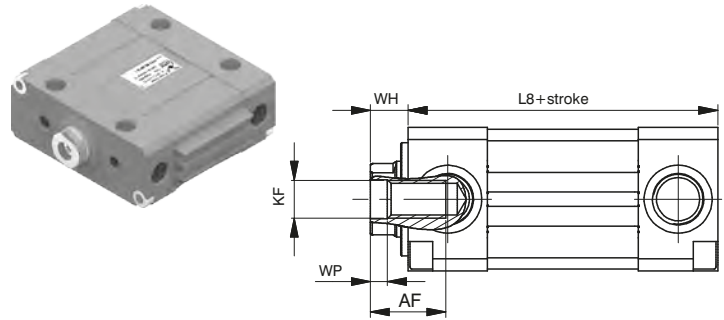

► **Basic version “2” male rod**

Ordering code
<b>SIDE CONNECTION</b>
1370.size.stroke.2 Magnetic chrome plated rod
1371.size.stroke.2 Magnetic stainless steel rod
1372.size.stroke.2 Non magnetic chrome plated rod
1373.size.stroke.2 Non magnetic stainless steel rod
<b>REAR CONNECTION</b>
1370.size.stroke.2.P Magnetic chrome plated rod
1371.size.stroke.2.P Magnetic stainless steel rod
1372.size.stroke.2.P Non magnetic chrome plated rod
1373.size.stroke.2.P Non magnetic stainless steel rod

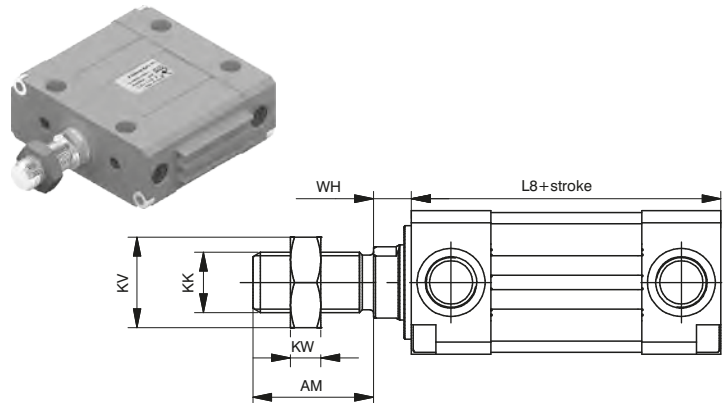

► **Female through rod cylinder version “3”**

Ordering code
1370.size.stroke.3 Magnetic chrome plated rod
1371.size.stroke.3 Magnetic stainless steel rod
1372.size.stroke.3 Non magnetic chrome plated rod
1373.size.stroke.3 Non magnetic stainless steel rod

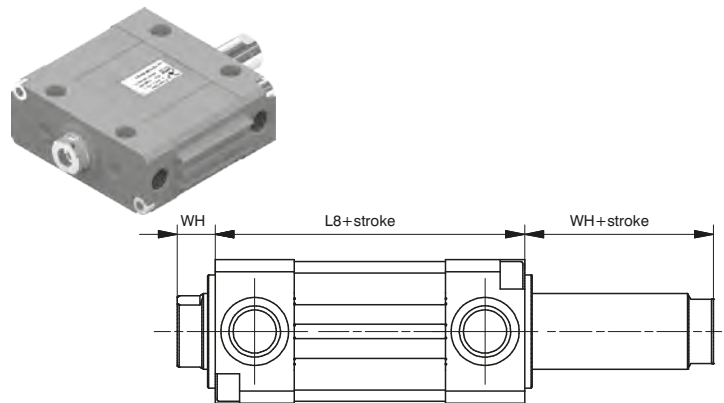

► **Male through rod cylinder version “4”**

Ordering code
1370.Size.stroke.4 Magnetic stelo cromato
1371.Size.stroke.4 Magnetic stelo inox
1372.Size.stroke.4 Non magnetico stelo cromato
1373.Size.stroke.4 Non magnetico stelo inox

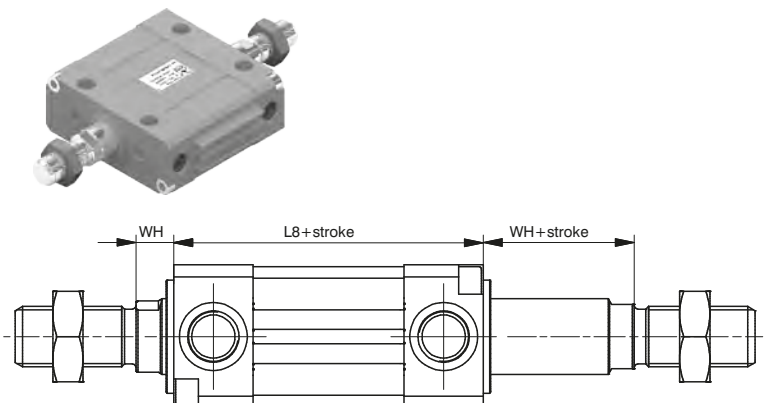

► **Variants**

Ordering code
137_.size.stroke._K = Version with aluminium piston

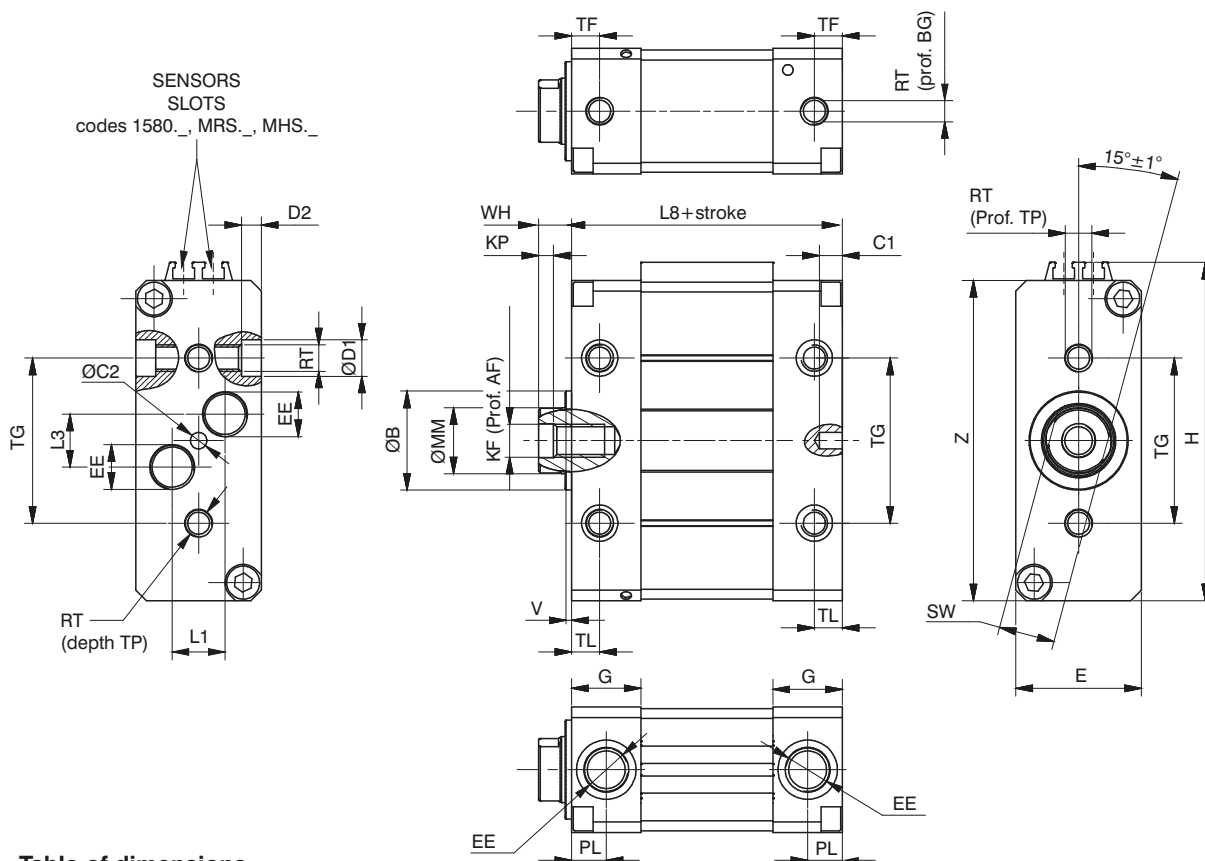

**Table of dimensions**

Size	25	32	40	50	63		
AM	22	22	24	32	32		
AF	12	14	16	20	20		
Ø B (h9)	16	20	25	30	30		
BG	8	9	9	12	14		
C1	7	7	7	7	7		
C2 (H9)	4	4	4	5	5		
Ø D1	8	10	10	11	15		
D2	4	4	5	6	6		
E	20	24	30	38	50		
EE	M5	G1/8"	G1/8"	G1/4"	G1/4"		
G	12	17	17	21	21		
H	56,5	65,5	82,5	102,5	127		
KF	M5	M6	M8	M10	M10		
KK	M10x1,25	M10x1,25	M12x1,25	M16x1,5	M16x1,5		
KP	2	2,5	3	4,5	4,5		
KV	17	17	19	24	24		
KW	6	6	7	8	8		
L1	6	7,5	7,5	16	19		
L3	10	14,5	14,5	16	21		
L8	62	72	76	82	82		
Ø MM	10	12	16	20	20		
PL	6,5	8,5	8,5	10,5	10,5		
RT	M5	M6	M6	M8	M10		
SW (H13)	8	10	13	17	17		
TF	5	8,5	8,5	8,5	8,5		
TG	25	32	40	50	60		
TL	5	8,5	8,5	8,5	8,5		
TP	8	9	9	12	14		
V	2	2	2	2	2		
VG	30	30	33	42	42		
WH	8	8	9	10	10		
Z	51	60	77	97	1215		
Weight g	Versions	1 stroke 0	180	285	482	848	1350
		2 stroke 0	203	309	520	929	1431
	every 10 mm		22	29	49	79	118
Weight g	Versions	3 stroke 0	195	314	534	959	1478
		4 stroke 0	242	362	610	1096	1615
	every 10 mm		28	38	65	103	143

PNEUMATIC ACTUATION

► **Front and rear flange**

Ordering code
<b>1370.Size.03</b>



Plate which allows anchorage of the cylinder at a right angle to the plane. Mounted to the cylinder by screws.

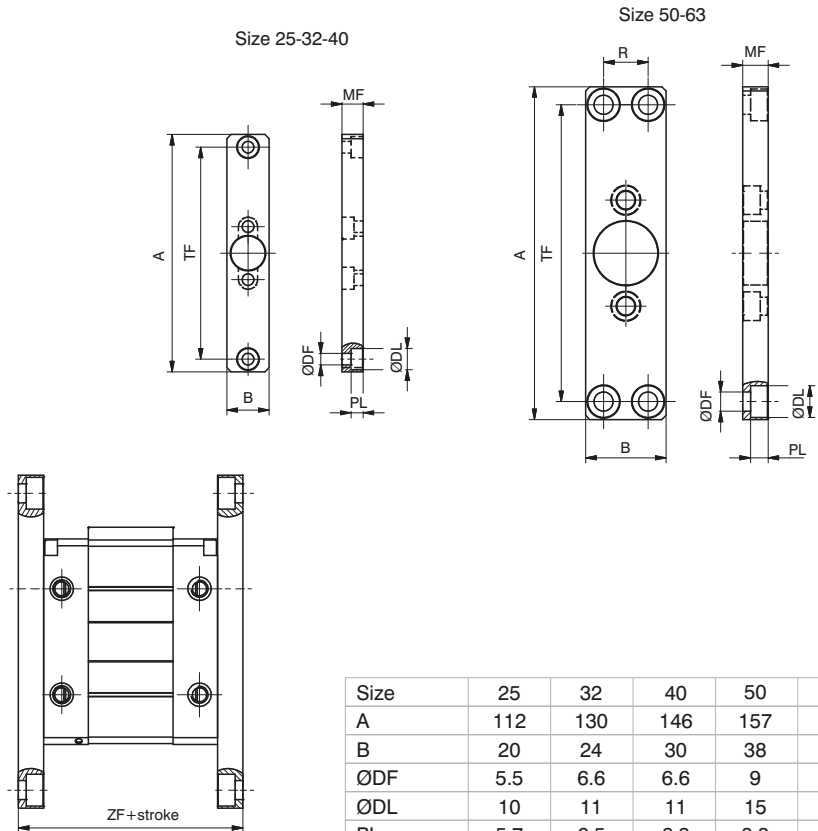

Size	25	32	40	50	63
A	112	130	146	157	157
B	20	24	30	38	50
ØDF	5.5	6.6	6.6	9	9
ØDL	10	11	11	15	15
PL	5.7	6.5	6.3	8.3	8.3
MF	10	10	10	12	15
R	/	/	/	21	33
TF	100	115	132	140	140
ZF	82	92	96	106	112

► **Foot bracket**

Ordering code
<b>1370.Size.05/1F</b> (n° 1 piece)



Brackets used to anchor the cylinder parallel to the mounting plane. Manufactured from steel with a rust proof protective treatment. Mounted to the cylinder end caps with bolts.

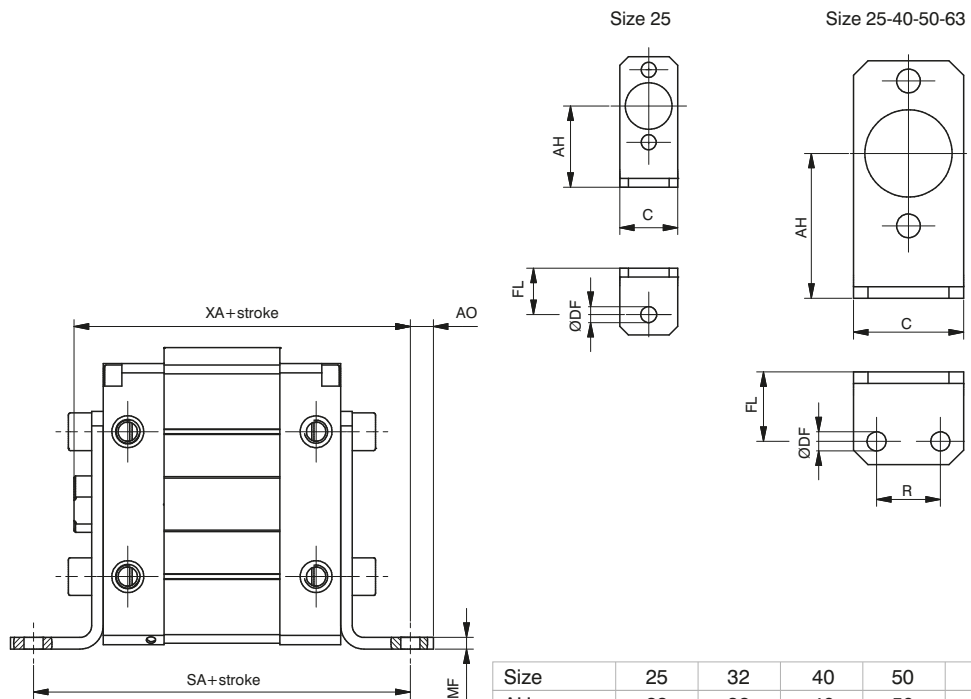

Size	25	32	40	50	63
AH	28	32	40	50	63
AO	7	5.5	7	8	10
C	20	24	30	38	50
ØDF	5.5	5.5	5.5	6.6	9
FL	16	18	20	24	27
MF	3	3	4	4	4
R	/	13	16	22	30
SA	94	108	116	130	136
XA	86	98	105	116	119

**Rear male clevis**

Ordering code

**1370.Size.09/1F**

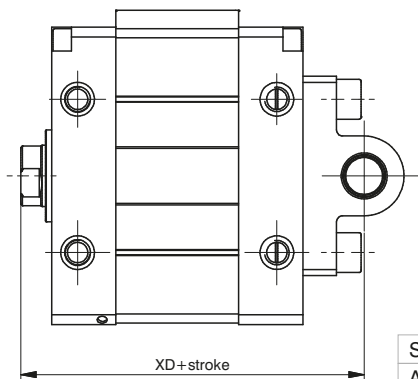
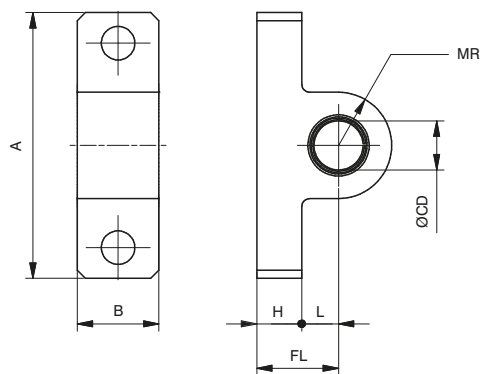

This type of mounting allows anchorage of the cylinder either parallel or right angle to plane; the cylinder rod can oscillate and self-align as necessary when under load.

Size	25	32	40	50	63
A	37	44	52	65	78
B	9	10.5	10.5	20	25
ØCD (H7)	8	10	12	12	16
FL	14	15	18	20	24
H	6	9	9	11	11
L	8	6	9	9	13
MR	7.5	10	13	13	17
XD	84	95	103	112	116

**Rear clevis**

Ordering code

**1370.Size.09F**

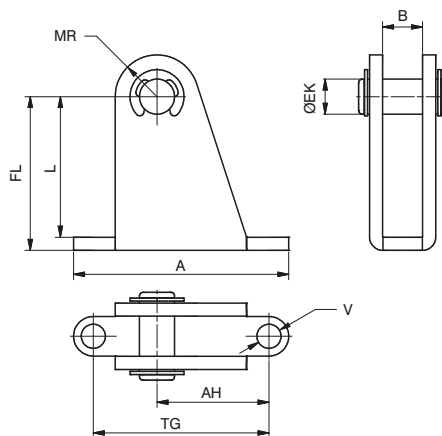
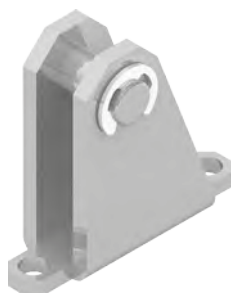

To be used in conjunction with 09/1 clevis.  
 Similar to type 08 but includes a hinge pin.  
 This type of mounting allows anchorage of the cylinder either parallel or right angle to plane; the cylinder rod can oscillate and self-align as necessary when under load.  
 Manufactured from sheet metal with rust proof protective treatment.

Size	25	32	40	50	63
A	49	60	60	46	60
AH	25.5	33	29.5	24	32
B	9.1	10.6	10.6	20.1	25.1
ØEK	8	10	12	12	16
FL	35	42	51	55	68
L	32	38	47	50	63
MR	9.5	11	14	14	18
TG	40	50	50	30	40
ØV	5.5	6.6	6.6	9	11

3 PNEUMATIC ACTUATION

**Fork**

Ordering code
<b>1320.32.13F</b> (for $\varnothing 25$ and $\varnothing 32$ )
<b>1320.40.13F</b> (for $\varnothing 40$ )
<b>1320.50.13F</b> (for $\varnothing 50$ )
<b>1320.63.13F</b> (for $\varnothing 63$ )

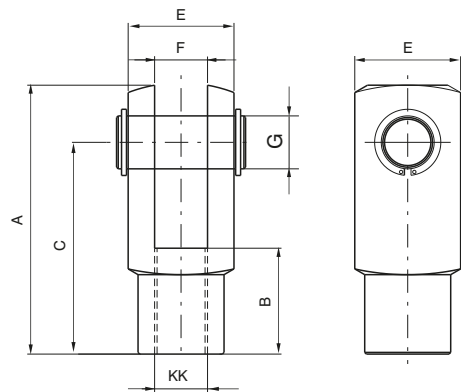

**Fork with clips**

Ordering code
<b>1320.32.13/1F</b> (for $\varnothing 25$ and $\varnothing 32$ )
<b>1320.40.13/1F</b> (for $\varnothing 40$ )
<b>1320.50.13/1F</b> (for $\varnothing 50$ )
<b>1320.63.13/1F</b> (for $\varnothing 63$ )

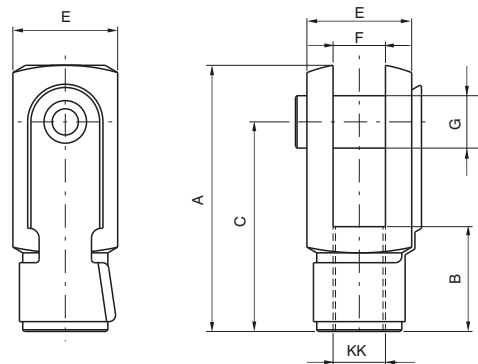

**Nut**

Ordering code
<b>1320.32.18F</b> (for $\varnothing 25$ and $\varnothing 32$ )
<b>1320.40.18F</b> (for $\varnothing 40$ )
<b>1320.50.18F</b> (for $\varnothing 50$ )
<b>1320.63.18F</b> (for $\varnothing 63$ )

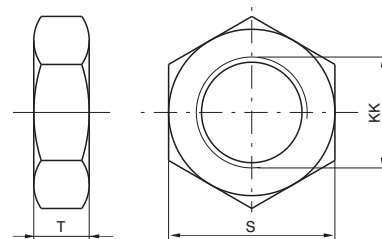

**Fork:**  
Element that when screwed to the rod consents a regular functioning even when there are significant lateral forces as the connection point. Made of zinc-plated steel.

**Nut:**  
Used to block the position of the fork.

Bore	25	32	40	50	63
A	52	52	62	83	83
B	20	20	24	32	32
C	40	40	48	64	64
E	20	20	24	32	32
F(B12)	10	10	12	16	16
G	10	10	12	16	16
S	17	17	19	24	24
T	6	6	7	8	8
KK	M10X1.25	M10X1.25	M12X1.25	M16X1.5	M16X1.5
Weight	fork	100	100	140	340
g	nut	15	15	20	20

**Ball joint**

Ordering code

- 1320.32.32F**  
(for ø25 and ø32)
- 1320.40.32F**  
(for ø40)
- 1320.50.32F**  
(for ø50)
- 1320.63.32F**  
(for ø63)

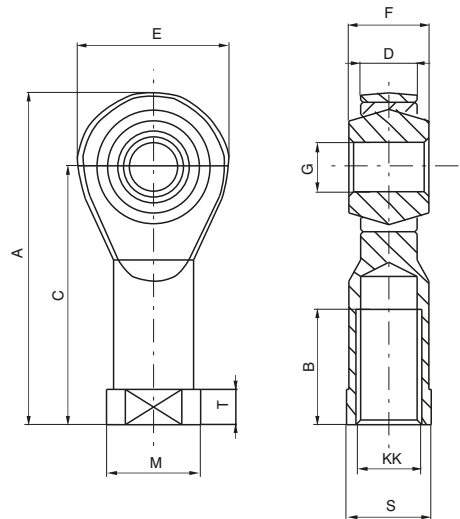

Bore	25	32	40	50	63
A	57	57	66	85	85
B	20	20	22	28	28
C	43	43	50	64	64
D (-0,1)	10.5	10.5	12	15	15
E	28	28	32	42	42
F	14	14	16	21	21
G (H 7)	10	10	12	16	16
KK	M10x1.25	M10x1.25	M12x1.25	M16x1.5	M16x1.5
M	19	19	22	27	27
S	17	17	19	22	22
T	6.5	6.5	6.5	8	8
Weight g	76	76	110	220	220

**Self-aligning joint**

Ordering code

- 1320.32.33F**  
(for ø25 and ø32)
- 1320.40.33F**  
(for ø40)
- 1320.50.33F**  
(for ø50)
- 1320.63.33F**  
(for ø63)

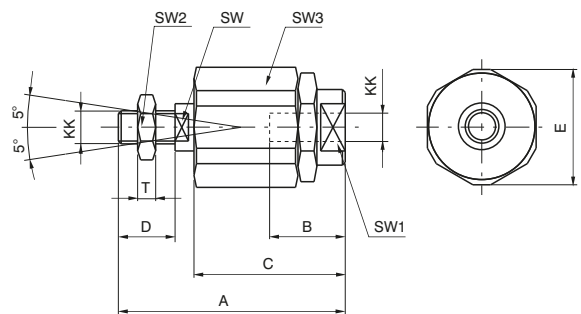

Bore	25	32	40	50	63
A	71	71	75	103	103
B	20	20	20	32	32
C	46	46	46	63	63
D	20	20	24	32	32
E	32	32	32	45	45
KK	M10x1,25	M10x1,25	M12x1,25	M16x1,5	M16x1,5
SW	12	12	12	20	20
SW1	19	19	19	27	27
SW2	17	17	19	24	24
SW3	30	30	30	41	41
T	6	6	7	8	8
Weight g	220	220	230	660	660

## Series 1400, Hydraulic speed control cylinders (Ø40 - Ø63)

### General

The SKIP and STOP valves are pneumatically actuated 2 ways poppet valves. The SKIP valve (accelerating device) is normally open and is equipped with a supplementary regulator for maximum speed control. It must be activated to obtain speed regulation.

The STOP valve can be normally closed or normally open.

### Construction characteristics

End caps	black anodised aluminium
Barrels	bright painted drawn steel
Rod	C43 chromed steel
Tie rods	plated zinc steel
Piston	aluminium
Waterproof seals	NBR rubber
Piston seal	FPM
Rod seal	PUR
Regulators group	brass
Skip and stop valves	black anodised aluminium
Circuit oil	hydraulic with viscosity 2.9° E at 50°C (viscosity index minimum 118)
Bore	40 mm and 63 mm diameter

### Technical characteristics

Max connecting load	600 kg (Ø40) -1200 Kg (Ø63)
Min. and max. speed	60 - 10000 mm/min.
Working temperature	-5°C - +70°C
Minimum pressure for the actuation of skip and stop valves	4 bar

### Standard strokes

50 - 100 - 150 - 200 - 250 - 300 - 350 - 400 - 450 - 500 mm  
minimum stroke for type 1400.stroke.03.05 and 1400.stroke.03.06, 150 mm.

**Important:** For heavier load we have available the hydraulic speed control check cylinders of 63 mm diameter suitable to withstand loads up to 1200 kg. For more information please contact our technical department.

### Maintenance

The speed control check is a closed system and there are no external factors that can adversely affect its function. Care however, has to be exercised not to allow the hydraulic fluid level to drop below the minimum indicated on the auxiliary tank. Should this occur, cavitation, or worse, an air pocket would result causing erratic control.

Additional fluid should be put in exclusively through a unidirectional valve by means of an appropriate syringe (such as our code number 1400.99.01). Excess fluid will be expelled through a vent into an appropriate container. It is necessary to completely disassemble the regulator and be sure to bleed the system to eliminate air pockets. We suggest that you create a vacuum before beginning to refill.

This can be done with a small unidirectional valve turned up and repeatedly loaded with a syringe.

The rod must be manually actuated successively releasing air through the valve using a small and pointed instrument.

### Functional schematics

#### Outward stroke Control

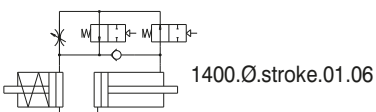
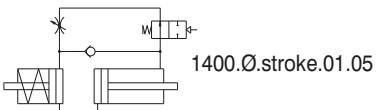
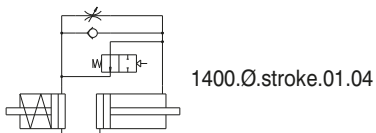
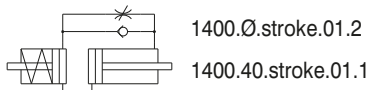

#### Inward stroke Control

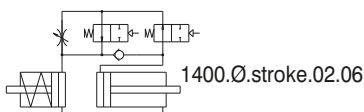
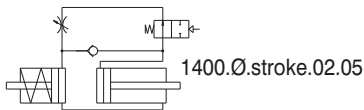
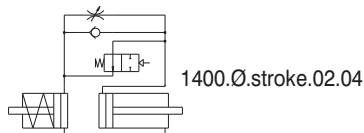
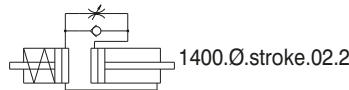

#### Inward & Outward stroke Control

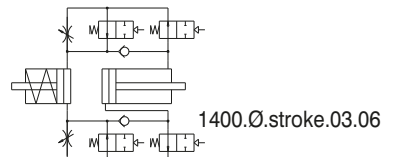
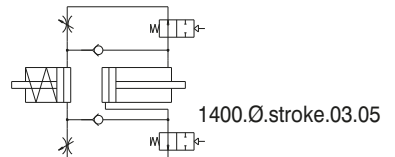
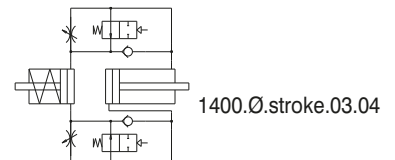
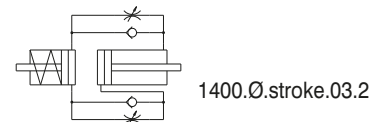



► Regulation on the outward stroke - Tank in line

Ordering code  
**1400.40.stroke.01.1**

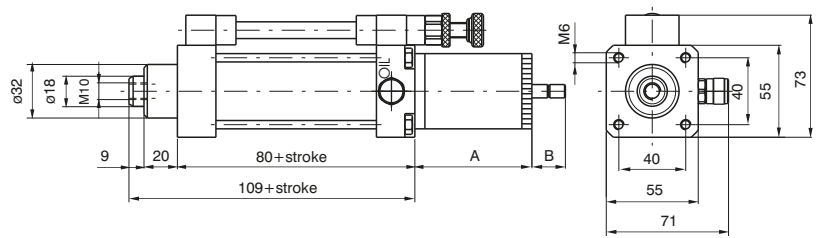

Weight g 1450 + g 300 every 50 mm. stroke

Strokes	A	B max.
< 75	78	30
75...<150	102	45
150...<250	127	60
250...<350	187	90
350...<500	202	120

► Regulation on the outward stroke – Lateral tank

Ordering code  
**1400.40.stroke.01.2**

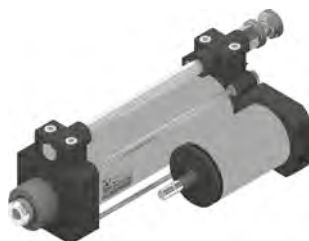
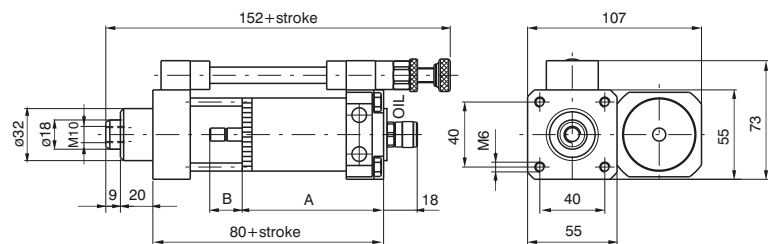

Weight g 1530 + g 300 every 50 mm. di stroke

Strokes	A	B max.
< 75	93	30
75...<150	118	45
150...<250	143	60
250...<350	183	90
350...<500	218	120

► Regulation on the inward stroke

Ordering code  
**1400.40.stroke.02.2**

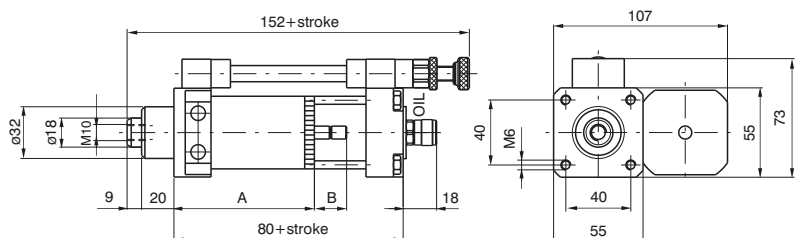

Weight g 1530 + g 300 every 50 mm. di stroke

Strokes	A	B max.
< 75	93	30
75...<150	118	45
150...<250	143	60
250...<350	183	90
350...<500	218	120

Regulation in both directions

Ordering code

1400.40.stroke.03.2

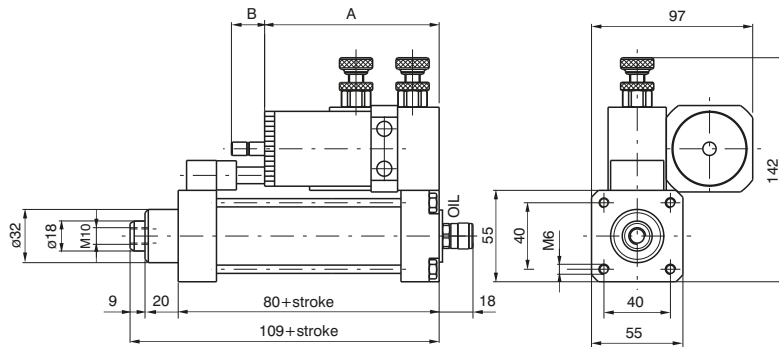

Attention: Minimum stroke=150mm when fitted in tandem (parallel or in-line) with 1319-1320-1321 cylinders series Ø80mm or Ø100mm.

Strokes	A	B max.
< 75	110	30
75...<150	135	45
150...<250	160	60
250...<350	200	90
350...<500	235	120

Weight g 1870 + g 300 every 50 mm. stroke

Regulation on the outward stroke with skip (Acceleration valve)

Ordering code

1400.40.stroke.01.04

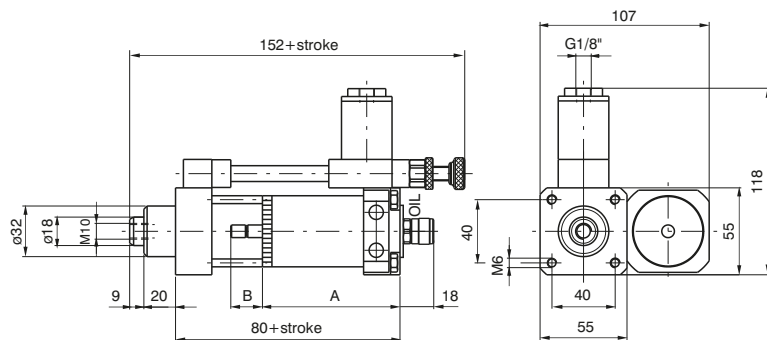

Strokes	A	B max.
< 75	93	30
75...<150	118	45
150...<250	143	60
250...<350	183	90
350...<500	218	120

Weight g 1670 + g 300 every 50 mm. stroke

Regulation on the outward stroke with stop (Stop valve)

Ordering code

1400.40.stroke.01.05

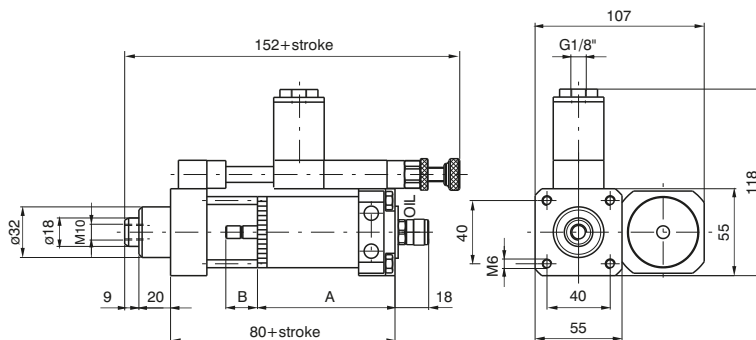

Strokes	A	B max.
< 75	93	30
75...<150	118	45
150...<250	143	60
250...<350	183	90
350...<500	218	120

Weight g 1710 + g 300 every 50 mm. stroke

3 PNEUMATIC ACTUATION

► Regulation on the outward stroke with skip and stop (Acceleration and stop valves)

Ordering code  
**1400.40.stroke.01.06**

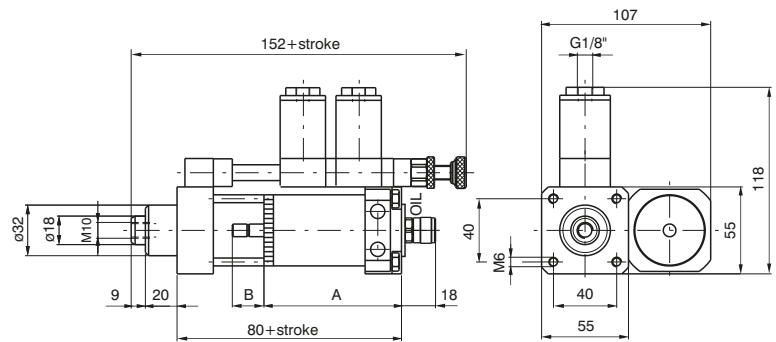
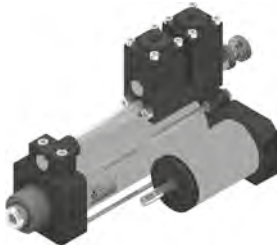

Strokes	A	B max.
< 75	93	30
75...<150	118	45
150...<250	143	60
250...<350	183	90
350...<500	218	120

Weight g 1830 + g 300 every 50 mm. stroke

► Regulation on the inward stroke with skip (Acceleration valve)

Ordering code  
**1400.40.stroke.02.04**

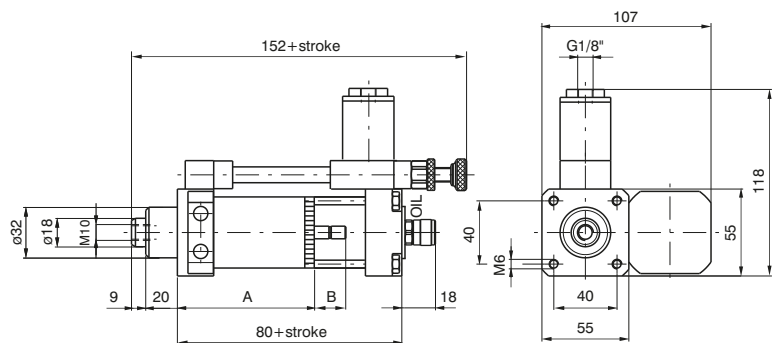

Strokes	A	B max.
< 75	93	30
75...<150	118	45
150...<250	143	60
250...<350	183	90
350...<500	218	120

Weight g 1670 + g 300 every 50 mm. stroke

► Regulation on the inward stroke with stop (Stop valve)

Ordering code  
**1400.40.stroke.02.05**

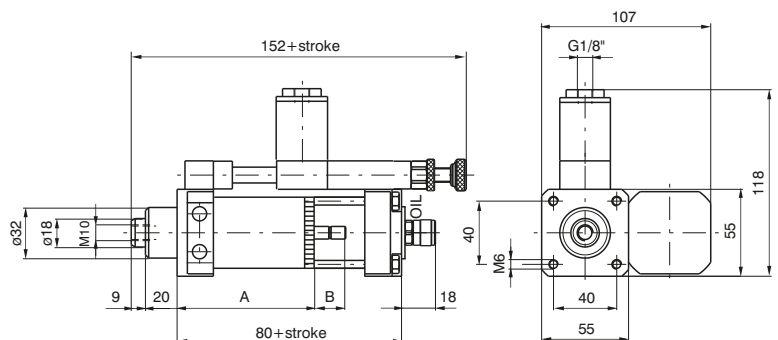

Strokes	A	B max.
< 75	93	30
75...<150	118	45
150...<250	143	60
250...<350	183	90
350...<500	218	120

Weight g 1710 + g 300 every 50 mm. stroke

Regulation on the inward stroke with skip and stop (Acceleration and stop valves)

Ordering code

1400.40.stroke.02.06

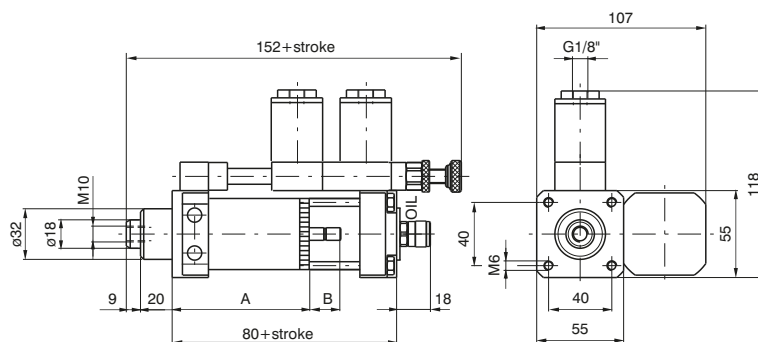

Strokes	A	B max.
< 75	93	30
75...<150	118	45
150...<250	143	60
250...<350	183	90
350...<500	218	120

Weight g 1830 + g 300 every 50 mm. stroke

Regulation in both directions with skip (Acceleration valves in both directions)

Ordering code

1400.40.stroke.03.04

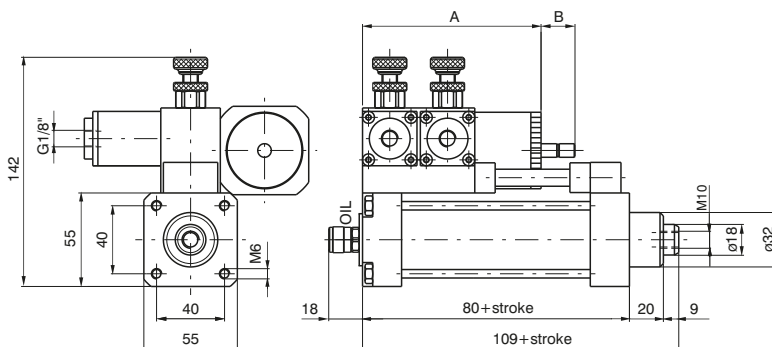
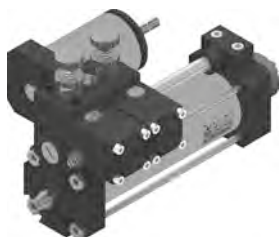

Strokes	A	B max.
< 75	110	30
75...<150	135	45
150...<250	160	60
250...<350	200	90
350...<500	235	120

Attention: Minimum stroke=150mm when fitted in tandem (parallel or in-line) with 1319-1320-1321 cylinders series Ø80mm or Ø100mm.

Weight g 2110 + g 300 every 50 mm. stroke

Regulation in both directions with stop (Stop valves in both directions)

Ordering code

1400.40.stroke.03.05

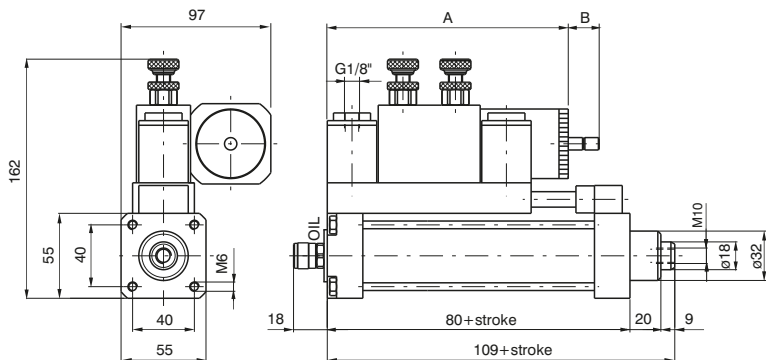
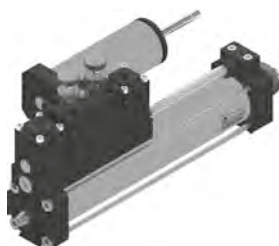

Strokes	A	B max.
150...<250	197	60
250...<350	237	90
350...<500	272	120

Min. stroke 150 mm  
Weight g 2390 + g 300 every 50 mm. stroke

► Regulation in both directions with skip and stop (Acceleration and stop valves in both

Ordering code
<b>1400.40.stroke.03.06</b>

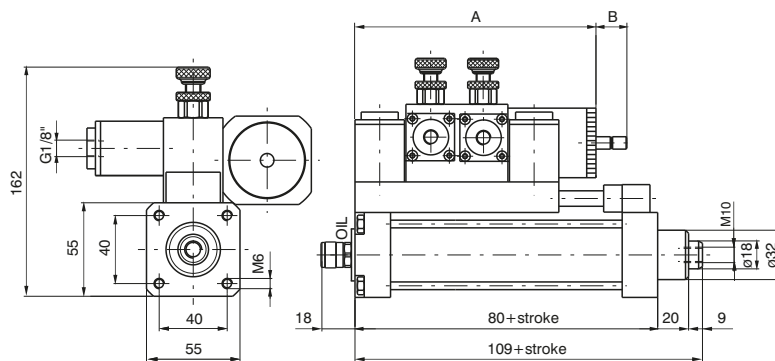
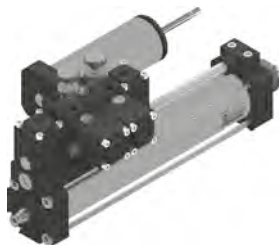

**Min. stroke 150 mm**  
Weight g 2630 + g 300 every 50 mm. stroke

Strokes	A	B max.
150 ... < 250	197	60
250 ... < 350	237	90
350 ... < 500	272	120

Regulation on the outward stroke – Lateral tank

Ordering code

1400.63.stroke.01.2

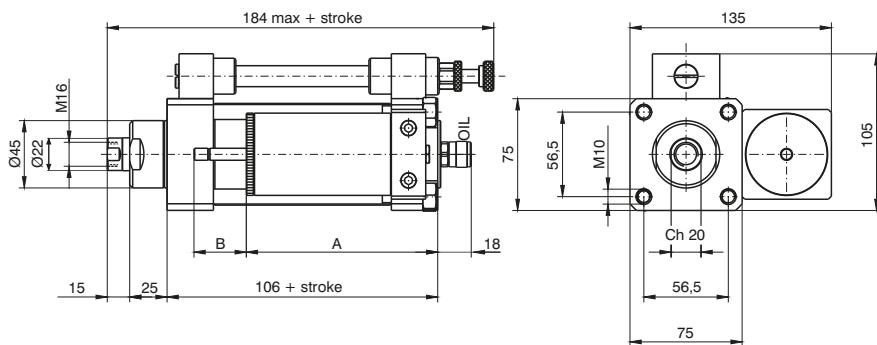
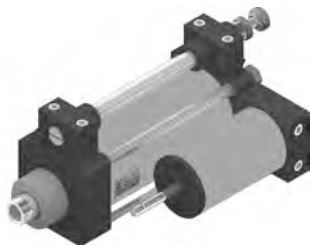

Strokes	A	B max
≥75 ... <150	128	50
≥150 ... <250	188	80
≥250 ... <350	238	100
≥350 ... <450	298	130
≥450 ... ≤600	358	160

Min. stroke 75 mm

Weight g 2950 + g 850 every 50 mm. stroke

Regulation on the inward stroke

Ordering code

1400.63.stroke.02.2

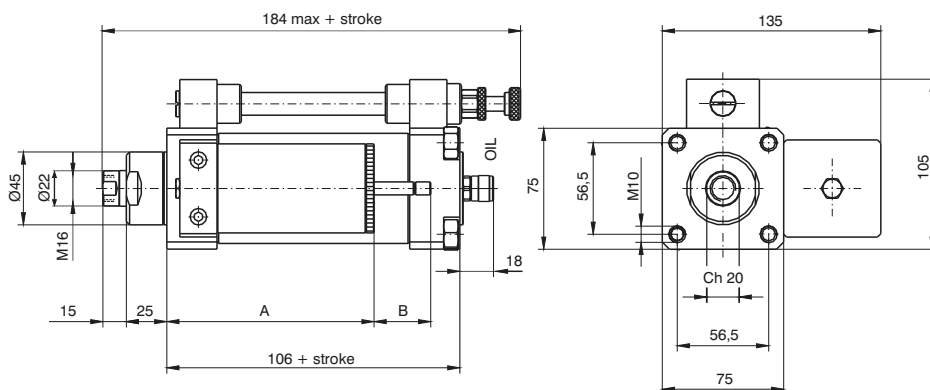

Strokes	A	B max
≥75 ... <150	128	50
≥150 ... <250	188	80
≥250 ... <350	238	100
≥350 ... <450	298	130
≥450 ... ≤600	358	160

Min. stroke 75 mm

Weight g 2950 + g 850 every 50 mm. stroke

Regulation in both directions

Ordering code

1400.63.stroke.03.2

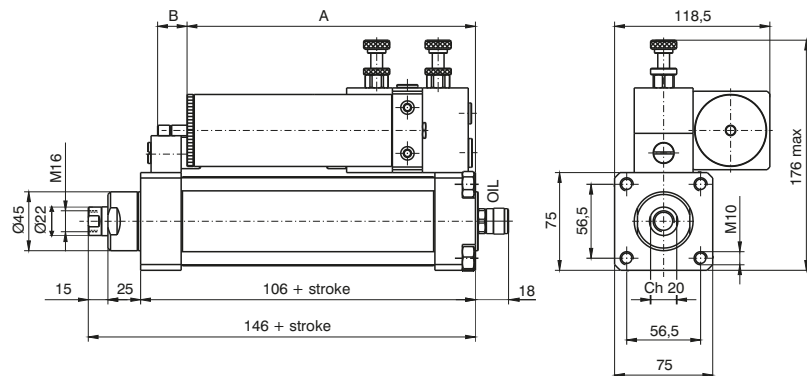
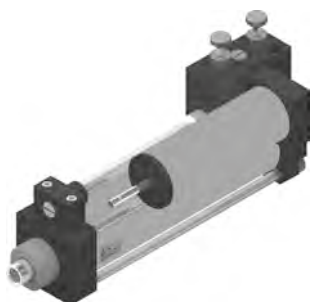

Strokes	A	B max
≥100 ... <150	160	50
≥150 ... <250	220	80
≥250 ... <350	270	100
≥350 ... <450	330	130
≥450 ... ≤600	390	160

Min. stroke 100 mm

Weight g 3600 + g 850 every 50 mm. stroke

► Regulation on the outward stroke with skip (Acceleration valve)

Ordering code  
**1400.63.stroke.01.04**

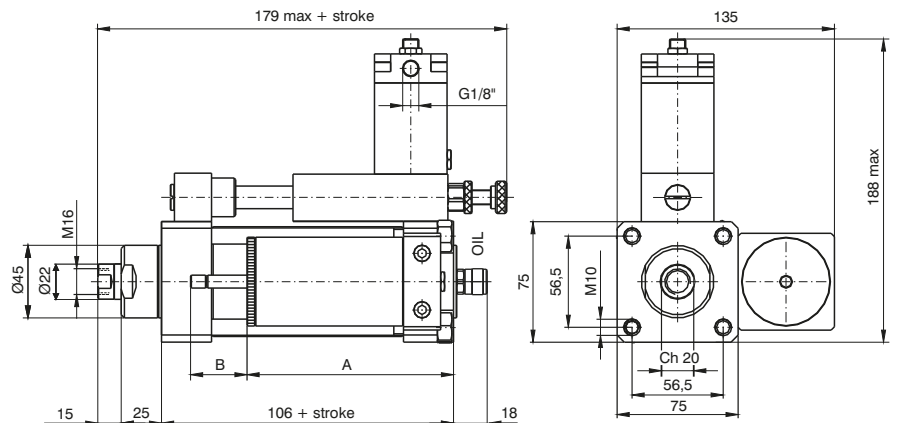

Strokes	A	B max
≥75 ... <150	128	50
≥150 ... <250	188	80
≥250 ... <350	238	100
≥350 ... <450	298	130
≥450 ... ≤600	358	160

Min. stroke 75 mm  
Weight g 3450 + g 850 every 50 mm. stroke

► Regulation on the outward stroke with stop (Stop valve)

Ordering code  
**1400.63.stroke.01.05**

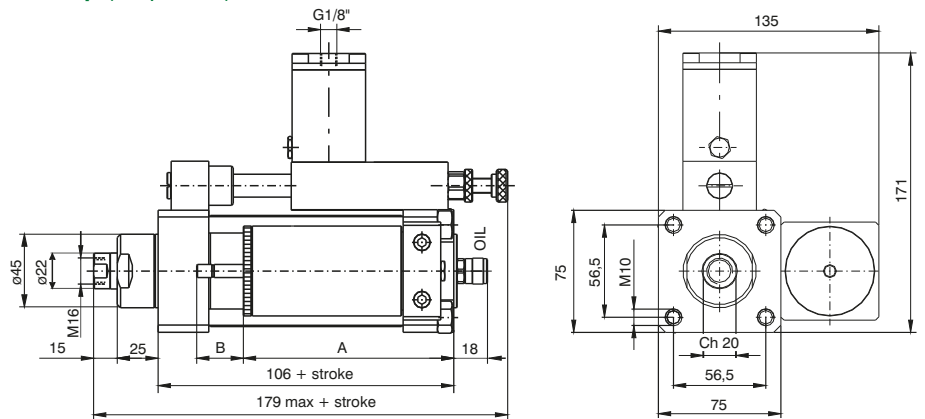
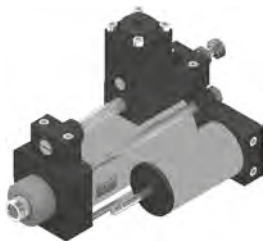

Strokes	A	B max
≥75 ... <150	128	50
≥150 ... <250	188	80
≥250 ... <350	238	100
≥350 ... <450	298	130
≥450 ... ≤600	358	160

Min. stroke 75 mm  
Weight g 3450 + g 850 every 50 mm. stroke

► Regulation on the outward stroke with skip and stop (Acceleration and stop valves)

Ordering code  
**1400.63.stroke.01.06**

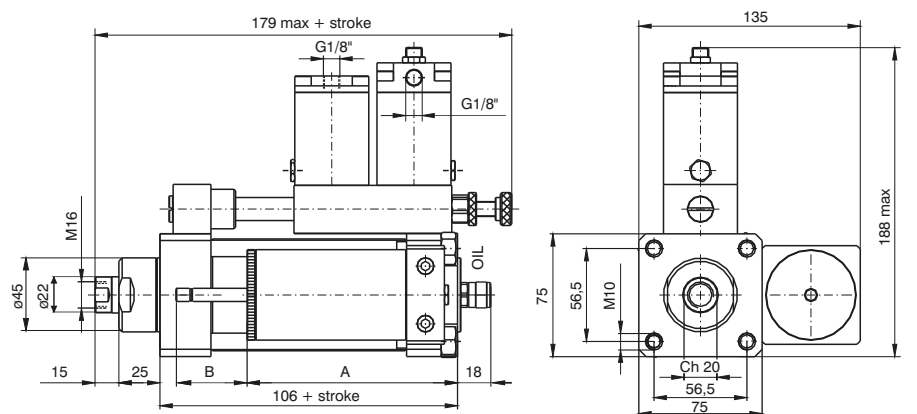
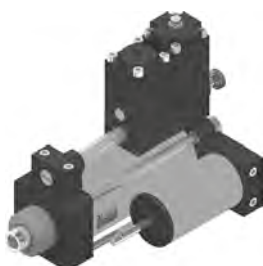

Strokes	A	B max
≥75 ... <150	128	50
≥150 ... <250	188	80
≥250 ... <350	238	100
≥350 ... <450	298	130
≥450 ... ≤600	358	160

Min. stroke 75 mm  
Weight g 3700 + g 850 every 50 mm. stroke

► Regulation on the inward stroke with skip (Acceleration valve)

Ordering code

1400.63.stroke.02.04

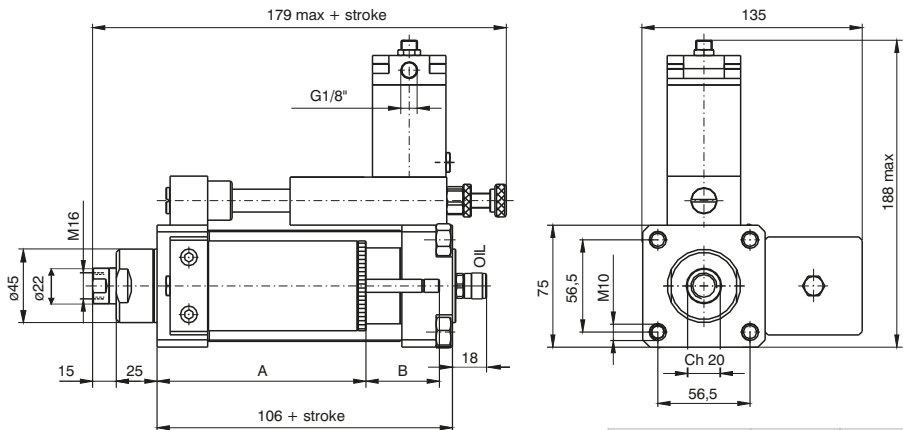

Strokes	A	B max
≥75 ... <150	128	50
≥150 ... <250	188	80
≥250 ... <350	238	100
≥350 ... <450	298	130
≥450 ... ≤600	358	160

Min. stroke 75 mm

Weight g 3450 + g 850 every 50 mm. stroke

► Regulation on the inward stroke with stop (Stop valves)

Ordering code

1400.63.stroke.02.05

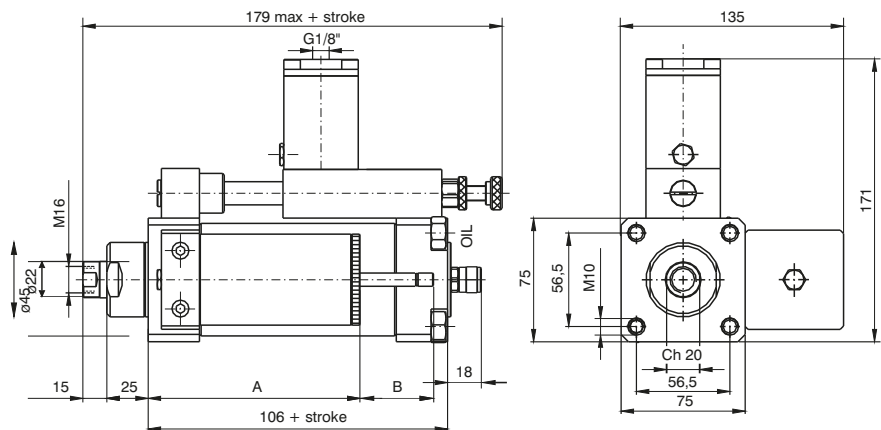
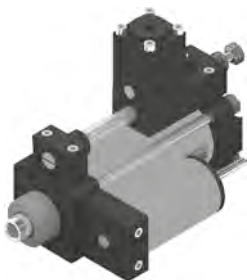

Strokes	A	B max
≥75 ... <150	128	50
≥150 ... <250	188	80
≥250 ... <350	238	100
≥350 ... <450	298	130
≥450 ... ≤600	358	160

Min. stroke 75 mm

Weight g 3450 + g 850 every 50 mm. stroke

► Regulation on the inward stroke with skip and stop (Acceleration and stop valve)

Ordering code

1400.63.stroke.02.06

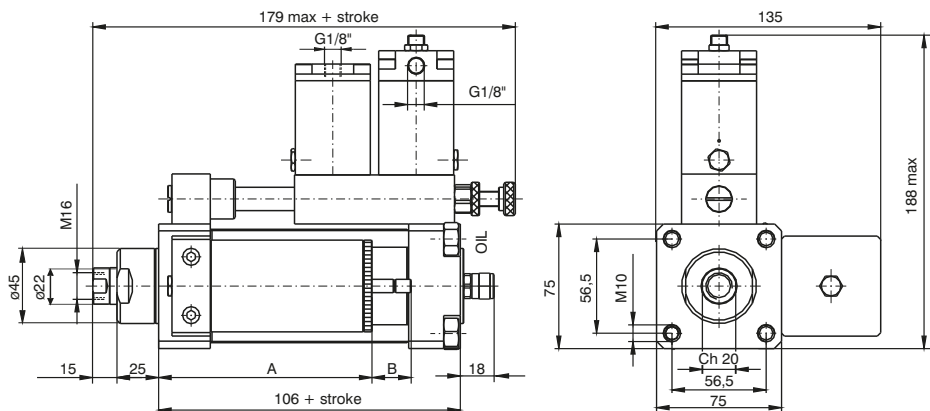
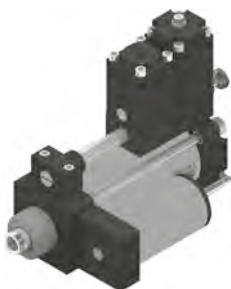

Strokes	A	B max
≥75 ... <150	128	50
≥150 ... <250	188	80
≥250 ... <350	238	100
≥350 ... <450	298	130
≥450 ... ≤600	358	160

Min. stroke 75 mm

Weight g 3700 + g 850 every 50 mm. stroke



► Regulation in both direction with skip (Accelerations valve in two directions)

Ordering code  
**1400.63.stroke.03.04**

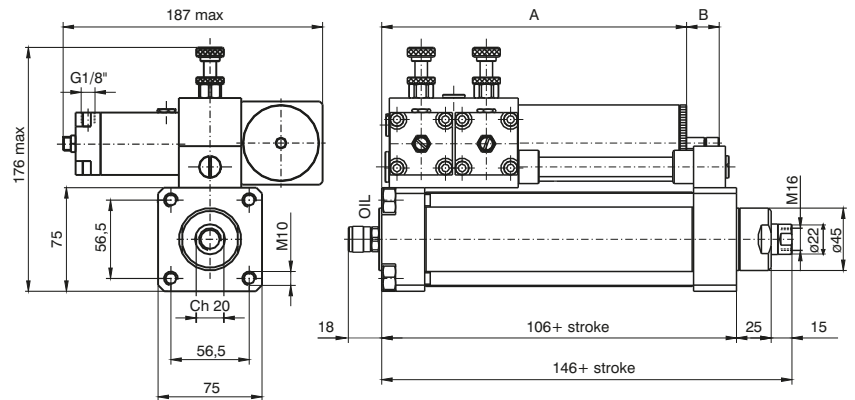
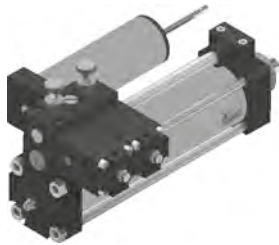

Strokes	A	B max
≥100 ... <150	160	50
≥150 ... <250	220	80
≥250 ... <350	270	100
≥350 ... <450	330	130
≥450 ... ≤600	390	160

Min. stroke 100 mm  
Weight g 4100 + g 850 every 50 mm. stroke

► Regulation in both direction with stop (Stop valves in two directions)

Ordering code  
**1400.63.stroke.03.05**

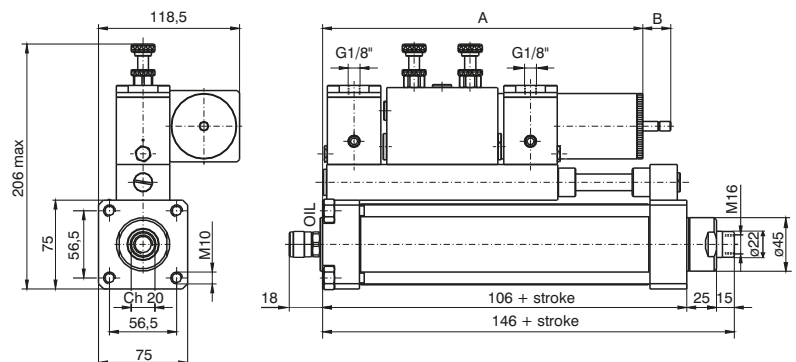
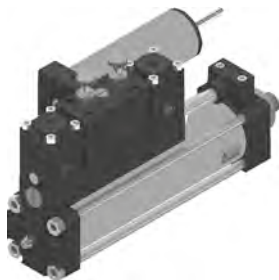

Strokes	A	B max
≥200 ... <250	269	80
≥250 ... <350	319	100
≥350 ... <450	379	130
≥450 ... ≤600	439	160

Min. stroke 200 mm  
Weight g 4850 + g 850 every 50 mm. stroke

► Regulation in both direction with skip and stop (Acceleration and stop valves in two directions)

Ordering code  
**1400.63.stroke.03.06**

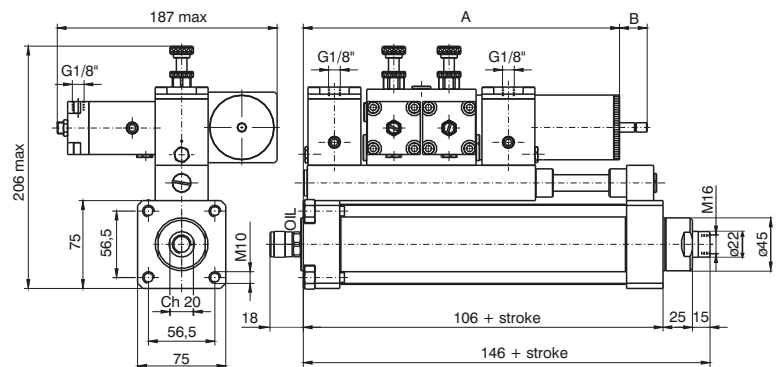
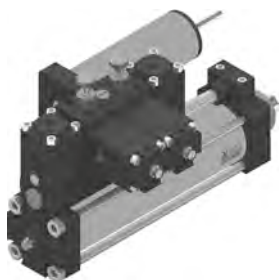

Strokes	A	B max
≥200 ... <250	269	80
≥250 ... <350	319	100
≥350 ... <450	379	130
≥450 ... ≤600	439	160

Min. stroke 200 mm  
Weight g 5400 + g 850 every 50 mm. stroke

**Dimensional releases and power supply positions with N.C. stop valves**

Ordering code
1400.Ø.stroke.01.07 regulation on the outward stroke + stop N.C.
1400.Ø.stroke.01.08 regulation on the outward stroke + skip + stop N.C.
1400.Ø.stroke.02.07 regulation on the inward stroke + stop N.C.
1400.Ø.stroke.02.08 regulation on the inward stroke + skip and stop N.C.
1400.Ø.stroke.03.07 regulation in both directions + stop N.C.
1400.Ø.stroke.03.08 regulation in both directions + skip + stop N.C.

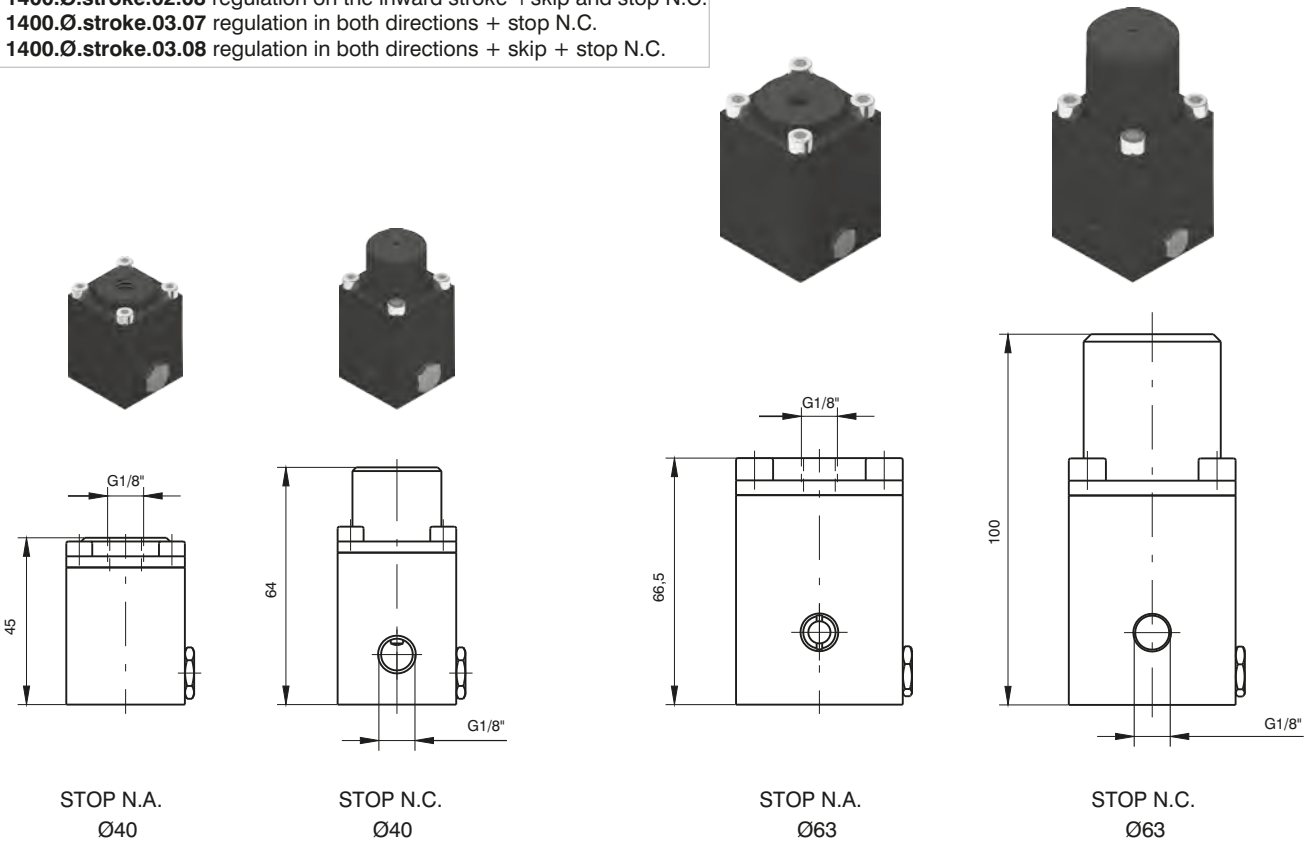

**Hydraulic fluid refill syringe**

Ordering code
1400.99.02



Weight g 420

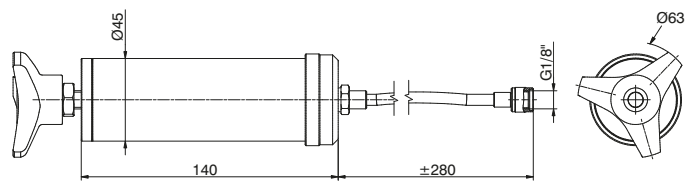

**Oil for hydraulic and pneumatic circuits**

Ordering code
<b>PNEUMOIL 01</b> (1 litre bottles)



This oil is suitable to lubricate pneumatic circuits and also to refill hydraulic speed control tanks. It is completely compatible with our seals.

## Series 1500 - Short stroke compact cylinders

### General

Profiled tube has three "T" slots on the three sides hosting sensors 1500.\_, RS.\_, HS.\_ without adaptors and with adaptor code 1380.01F codes 1580.\_, MRS.\_, MHS.\_.

A complete range of clamps makes them easy to install under any conditions.

It is interesting to note that as these cylinders (from Ø 32 to Ø 100) have anchoring holes with the same lead and thread as those of series 1320 ISO 6431, they accept all mountings except for the intermediate trunnion.

### Construction characteristics

Body	anodised aluminium
Rod	C43 chromed steel (stainless steel for magnetic cylinder Ø20 and Ø25)
Piston	aluminium
Rod bushing	anodised aluminium
End cap	anodised aluminium
Seals	Standard: NBR oil resistant rubber, PUR piston rod seals (HNBR or FPM seals available upon request)

### Operational characteristics

Fluid	Filtered air. No lubrication needed, if applied it shall be continuous.
Max. pressure	10 bar
Working temperature	-5°C - +70°C with standard seals magnetic or non magnetic piston -5°C - +80°C with FPM seals magnetic piston -5°C - +80°C with HNBR seals magnetic piston -5°C - +120°C with HNBR seals non magnetic piston -5°C - +150°C with FPM seals non magnetic piston

Please follow the suggestions below to ensure a long life for these cylinders:

- use clean and lubricated air
- correct alignment during assembly with regard to the applied load so as to avoid radial components or bending the rod.
- avoid high speeds together with long strokes and heavy loads: this would produce kinetic energy which the cylinder cannot absorb, especially if used as a limit stop (in this case use mechanical stop device)
- evaluate the environmental characteristics of cylinder used (high temperature, hard atmosphere, dust, humidity etc.)

**Please note: air must be dried for applications with lower temperature.**

Use hydraulic oils H class (ISO VG32) for correct continued lubrication.

Our Technical Department will be glad to help.

### Standard strokes

#### Double acting version

**Series 1501, 1504, 1511, 1514, 1515, 1516, 1517 and 1518**

for all bores from 5 to 50 mm every 5 mm.

On request are available strokes as follow:

**Ø 20 and Ø25** up to stroke 250 mm

**Ø 32 e Ø 40** up to stroke 300 mm

**Ø 50 e Ø 63** up to stroke 350 mm

**Ø 80 e Ø 100** up to stroke 400 mm

#### Single acting version

**Series 1502, 1503, 1512 and 1513:**

For all bores from 5 to 10 mm.

On request are available strokes up to 50 mm

#### Type with non-rotating device:

**Ø 20 and Ø 25** from 5 to 40 mm every 5 mm.

**Ø 32 and Ø 40** from 5 to 50 mm every 5 mm.

**Ø 50 and Ø 63** from 5 to 60 mm every 5 mm.

**Ø 80 and Ø 100** from 5 to 80 mm every 5 mm.

**Double acting version**

Ordering code

**1501.Ø.stroke** standard seals  
**1501.Ø.stroke.V** FPM seals  
**1501.Ø.stroke.T** HNBR seals

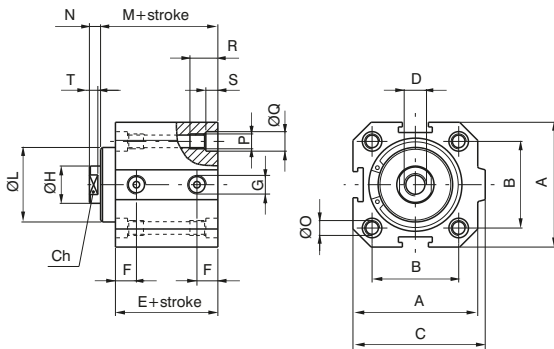

**Double acting version with magnetic piston**

Ordering code

**1511.Ø.stroke** standard seals  
**1511.Ø.stroke.V** FPM seals  
**1511.Ø.stroke.T** HNBR seals

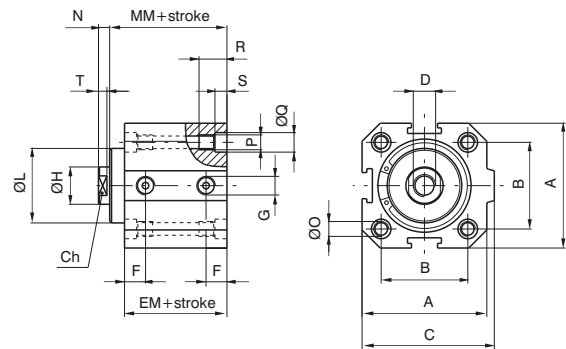

PNEUMATIC ACTUATION

Bore	20	25	32	40	50	63	80	100
A	35	41	48	57	67	80	100	120
B	26	28	32,5	38	46,5	56,5	72	89
C	39,5	44,5	52	61	71	84	106	126
D	M4x8	M5x10	M6x12	M10x15	M12x18	M12x18	M16x20	M16x20
E	29	30,5	32	33,5	35	38	44	47
EM	34	35,5	37	38,5	40	43	49	52
F	9	9,15	9,75	10,5	11	11,25	13,75	15,25
G	G 1/8"	G 1/8"	G 1/8"	G 1/8"	G 1/8"	G 1/8"	G 3/8"	G 3/8"
Ø H	8	10	12	16	20	20	25	25
Ø L ±0,05 (0,1 per Ø80 e Ø 100)	17	20,5	26	31	39	40	55	55
M	32	33	35,5	39,5	43	46	51,5	54,5
MM	37	38	40,5	44,5	48	51	56,5	59,5
N	4	4	4	5	6	6	8	8
Ø O	4,3	5,3	5,3	5,3	7	7	9	9
P	M5	M6	M6	M6	M8	M8	M10	M10
Ø Q	7,5	8,5	8,5	8,5	10,5	10,5	13,5	13,5
R	15	18	18	18	22	22	30	30
S	4,5	5,5	5,5	5,5	6,5	6,5	8,5	8,5
T	3	3	3	4	4,5	4,5	5,5	5,5
Ch	6	8	10	13	17	17	22	22

**Non magnetic**

Weight	stroke 0	75	110	170	260	400	600	800	1500
	every 10 mm.	20	30	40	60	80	100	120	145

**Magnetic**

Weight	stroke 0	90	130	200	310	460	700	910	1620
	every 10 mm.	20	30	40	60	80	100	120	145

► Single acting version with front spring

Ordering code

1502.Ø.stroke standard seals  
1502.Ø.stroke.V FPM seals  
1502.Ø.stroke.T HNBR seals

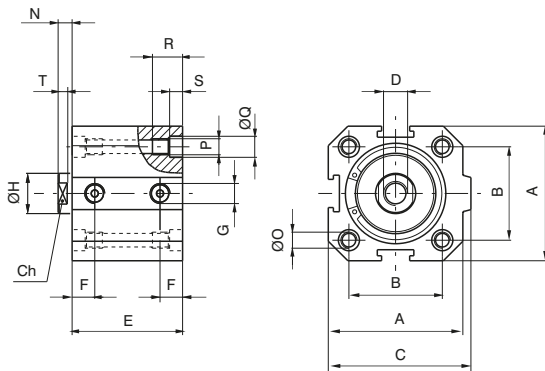

► Single acting version front spring with magnetic piston

Ordering code

1512.Ø.stroke standard seals  
1512.Ø.stroke.V FPM seals  
1512.Ø.stroke.T HNBR seals

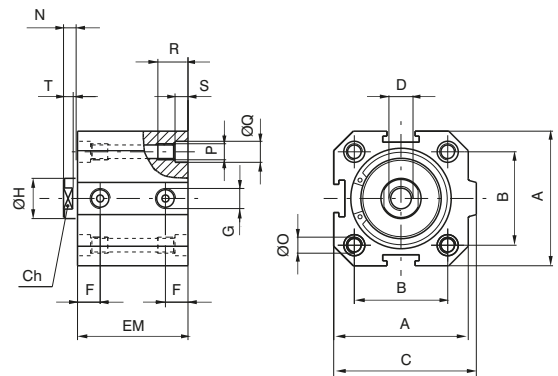

Bore		20	25	32	40	50	63	80	100
A		35	41	48	57	67	80	100	120
B		26	28	32,5	38	46,5	56,5	72	89
C		39,5	44,5	52	61	71	84	106	126
D		M4X8	M5X10	M6X12	M10X15	M12X18	M12X18	M16X20	M16X20
E	stroke 5	29	30,5	32	33,5	35	38	44	47
	stroke 10	34	35,5	37	38,5	40	43	49	52
EM	stroke 5	34	35,5	37	38,5	40	43	49	52
	stroke 10	39	40,5	42	43,5	45	48	54	57
F		9	9,15	9,75	10,5	11	11,25	13,75	15,25
G		G 1/8"	G 1/8"	G 1/8"	G 1/8"	G 1/8"	G 1/8"	G 3/8"	G 3/8"
Ø H		8	10	12	16	20	20	25	25
N		4	4	4	5	6	6	8	8
Ø O		4,3	5,3	5,3	5,3	7	7	9	9
P		M5	M6	M6	M6	M8	M8	M10	M10
Ø Q		7,5	8,5	8,5	8,5	10,5	10,5	13,5	13,5
R		15	18	18	18	22	22	30	30
S		4,5	5,5	5,5	5,5	6,5	6,5	8,5	8,5
T		3	3	3	4	4,5	4,5	5,5	5,5
Ch		6	8	10	13	17	17	22	22

Non magnetic

Weight g	stroke 5	70	105	160	250	370	550	750	1440
	stroke 10	80	120	180	280	410	600	810	1500

Magnetic

Weight g	stroke 5	85	125	190	300	430	650	860	1560
	stroke 10	95	140	210	330	470	700	920	1620

► **Single acting version with rear spring**

Ordering code

**1503.Ø.stroke** standard seals  
**1503.Ø.stroke.V** FPM seals  
**1503.Ø.stroke.T** HNBR seals

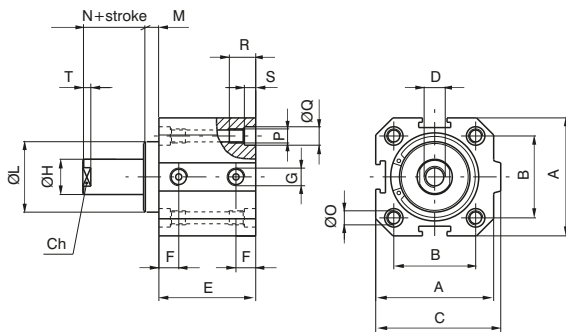

► **Single acting version rear spring with magnetic piston**

Ordering code

**1513.Ø.stroke** standard seals  
**1513.Ø.stroke.V** FPM seals  
**1513.Ø.stroke.T** HNBR seals

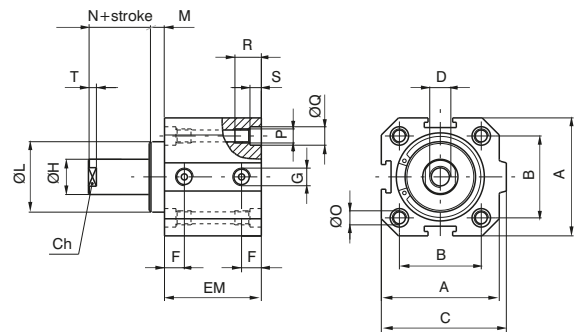

PNEUMATIC ACTUATION

Bore	20	25	32	40	50	63	80	100	
A	35	41	48	57	67	80	100	120	
B	26	28	32,5	38	46,5	56,5	72	89	
C	39,5	44,5	52	61	71	84	106	126	
D	M4X8	M5X10	M6X12	M10X15	M12X18	M12X18	M16X20	M16X20	
E	stroke 5	29	30,5	32	33,5	35	38	44	47
	stroke 10	34	35,5	37	38,5	40	43	49	52
EM	stroke 5	34	35,5	37	38,5	40	43	49	52
	stroke 10	39	40,5	42	43,5	45	48	54	57
F	9	9,15	9,75	10,5	11	11,25	13,75	15,25	
G	G 1/8"	G 1/8"	G 1/8"	G 1/8"	G 1/8"	G 1/8"	G 3/8"	G 3/8"	
Ø H	8	10	12	16	20	20	25	25	
Ø L ±0,05 (0,1 per Ø80 e Ø 100)	17	20,5	26	31	39	40	55	55	
M	3	2,5	3,5	6	8	8	7,5	7,5	
N	4	4	4	5	6	6	8	8	
Ø O	4,3	5,3	5,3	5,3	7	7	9	9	
P	M5	M6	M6	M6	M8	M8	M10	M10	
Ø Q	7,5	8,5	8,5	8,5	10,5	10,5	13,5	13,5	
R	15	18	18	18	22	22	30	30	
S	4,5	5,5	5,5	5,5	6,5	6,5	8,5	8,5	
T	3	3	3	4	4,5	4,5	5,5	5,5	
Ch	6	8	10	13	17	17	22	22	

**Non magnetic**

Weight g	stroke 5	70	105	160	250	370	550	750	1440
	stroke 10	80	120	180	280	410	600	810	1500

**Magnetic**

Weight g	stroke 5	85	125	190	300	430	650	860	1560
	stroke 10	95	140	210	330	470	700	920	1620

► Double acting through rod cylinder version

Ordering code

1504.Ø.stroke standard seals  
1504.Ø.stroke.V FPM seals  
1504.Ø.stroke.T HNBR seals

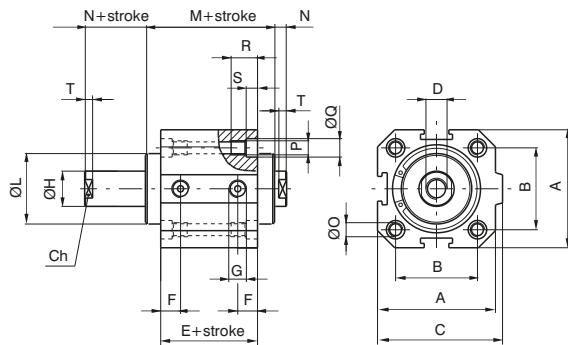

► Double acting through rod cylinder version with magnetic piston

Ordering code

1514.Ø.stroke standard seals  
1514.Ø.stroke.V FPM seals  
1514.Ø.stroke.T HNBR seals

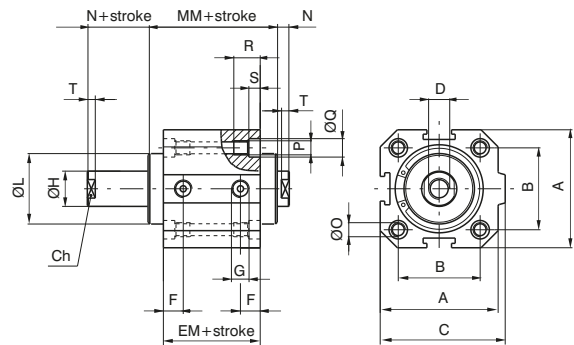

Bore	20	25	32	40	50	63	80	100
A	35	41	48	57	67	80	100	120
B	26	28	32,5	38	46,5	56,5	72	89
C	39,5	44,5	52	61	71	84	106	126
D	M4X8	M5X10	M6X12	M10X15	M12X18	M12X18	M16X20	M16X20
E	29	30,5	32	33,5	35	38	44	47
EM	34	35,5	37	38,5	40	43	49	52
F	9	9,15	9,75	10,5	11	11,25	13,75	15,25
G	G 1/8"	G 1/8"	G 1/8"	G 1/8"	G 1/8"	G 1/8"	G 3/8"	G 3/8"
Ø H	8	10	12	16	20	20	25	25
Ø L ±0,05 (0,1 per Ø80 e Ø 100)	17	20,5	26	31	39	40	55	55
M	35	35,5	39	45,5	51	54	59	62
MM	40	40,5	44	50,5	56	59	64	67
N	4	4	4	5	6	6	8	8
Ø O	4,3	5,3	5,3	5,3	7	7	9	9
P	M5	M6	M6	M6	M8	M8	M10	M10
Ø Q	7,5	8,5	8,5	8,5	10,5	10,5	13,5	13,5
R	15	18	18	18	22	22	30	30
S	4,5	5,5	5,5	5,5	6,5	6,5	8,5	8,5
T	3	3	3	4	4,5	4,5	5,5	5,5
Ch	6	8	10	13	17	17	22	22

Non magnetic

Weight g	stroke 0	90	130	200	320	460	670	1100	1680
	every 10 mm.	20	35	50	70	90	110	155	185

Magnetic

Weight g	stroke 0	105	160	240	380	530	740	1210	1820
	every 10 mm.	20	35	50	70	90	110	155	185

**Tandem with opposed rods**

Ordering code

- 1515.Ø.stroke.stroke 1 standard seals
- 1515.Ø.stroke.stroke 1.V FPM seals
- 1515.Ø.stroke.stroke 1.T HNBR seals
- 1515.Ø.stroke.stroke 1.M standard seals, magnetic piston
- 1515.Ø.stroke.stroke 1.MV FPM seals, magnetic piston
- 1515.Ø.stroke.stroke 1.MT HNBR seals, magnetic piston

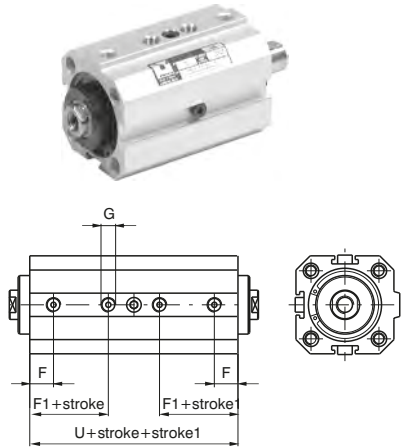

**Tandem push with common rods**

Ordering code

- 1516.Ø.stroke standard seals
- 1516.Ø.stroke.V FPM seals
- 1516.Ø.stroke.T HNBR seals
- 1516.Ø.stroke.M standard seals, magnetic piston
- 1516.Ø.stroke.MV FPM seals, magnetic piston
- 1516.Ø.stroke.MT HNBR seals, magnetic piston

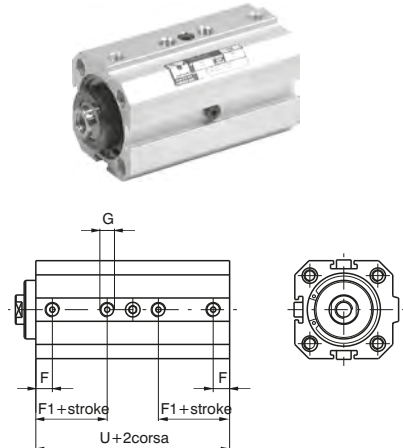

**Tandem push with independent rods**

Ordering code

- 1517.Ø.stroke.stroke 1 standard seals
- 1517.Ø.stroke.stroke 1.V FPM seals
- 1517.Ø.stroke.stroke 1.T HNBR seals
- 1517.Ø.stroke.stroke 1.M standard seals, magnetic piston
- 1517.Ø.stroke.stroke 1.MV FPM seals, magnetic piston
- 1517.Ø.stroke.stroke 1.MT HNBR seals, magnetic piston

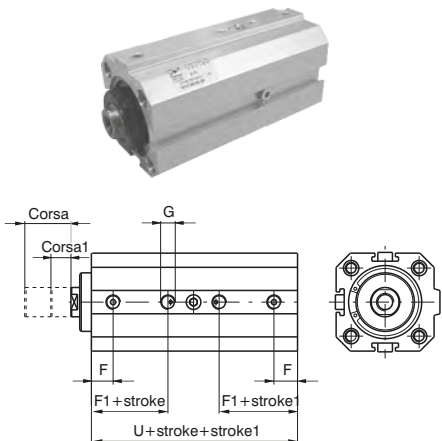

**Opposed tandem with common rods**

Ordering code

- 1518.Ø.stroke.stroke 1 standard seals
- 1518.Ø.stroke.stroke 1.V FPM seals
- 1518.Ø.stroke.stroke 1.T HNBR seals
- 1518.Ø.stroke.stroke 1.M standard seals, magnetic piston
- 1518.Ø.stroke.stroke 1.MV FPM seals, magnetic piston
- 1518.Ø.stroke.stroke 1.MT HNBR seals, magnetic piston

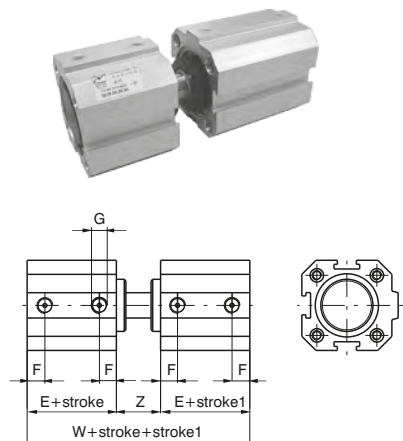

Bore	20	25	32	40	50	63	80	100
E	29	30,5	32	33,5	35	38	44	47
F	9	9,15	9,75	10,5	11	11,25	13,75	15,25
F1	17,5	18,35	19,75	20,5	21,5	24,25	24,75	26,25
G	G 1/8"	G 1/8"	G 1/8"	G 1/8"	G 1/8"	G 1/8"	G 3/8"	G 3/8"
U	59	60,5	67	68,5	70	78	89	97
W	72	74	79	89	98	104	119	125
Z	14	13	15	22	28	28	31	31

**Variations with magnetic piston**

E	34	35,5	37	38,5	40	43	49	52
F1	22,5	23,35	24,75	25,5	26,5	29,25	29,75	31,25
U	69	70,5	77	78,5	80	88	99	107
W	82	84	89	99	108	114	129	135



► Double acting version

Ordering code
1501.Ø.stroke.AR standard seals
1501.Ø.stroke.AR.V FPM seals
1501.Ø.stroke.AR.T HNBR seals

► Double version with magnetic piston

Ordering code
1511.Ø.stroke.AR standard seals
1511.Ø.stroke.AR.V FPM seals
1511.Ø.stroke.AR.T HNBR seals

Cylinders with non-rotating device

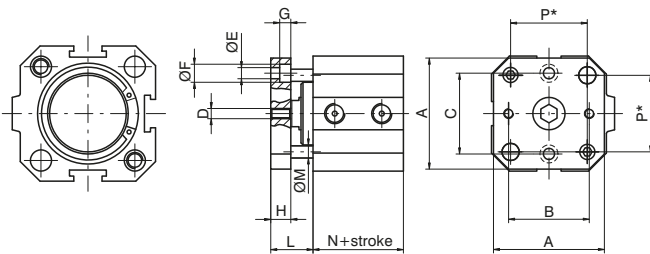
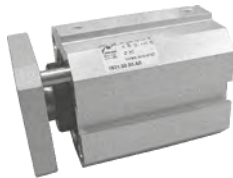

\* = Distance between rods centres

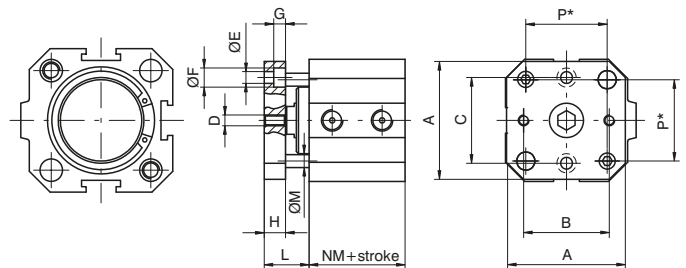

\* = Distance between rods centres

It is possible, upon request to have four holes threaded and with counter bores in order to rear mount the cylinder as if it was standard.

3 PNEUMATIC ACTUATION

Bore	20	25	32	40	50	63	80	100		
A	35	40	45	55	65	80	100	120		
B	22	26	32	40	50	62	82	103		
C	22	28	34	40	50	62	82	103		
D	M4	M5	M5	M5	M6	M6	M8	M8		
Ø E	4,5	5,5	5,5	5,5	6,5	8,5	8,5	8,5		
Ø F	7,5	9	9	9	10,5	13,5	13,5	13,5		
G	4,5	5,5	5,5	5,5	6,5	8,5	8,5	8,5		
H	8	8	10	10	12	12	15	15		
L	15	14,5	17,5	21	26	26	30,5	30,5		
Ø M	6	6	6	6	8	8	10	10		
N	29	30,5	32	33,5	35	38	44	47		
NM	34	35,5	37	38,5	40	43	49	52		
P	26	28	32,5	38	46,5	56,5	72	89		
Max. suggestion stroke	40	40	50	50	60	60	80	80		
Weight	stroke 0		40	50	70	90	200	250	490	650
g	5	5	5	5	10	10	20	20		

**Rear clevis**

Ordering code

**1500.Ø.09F**

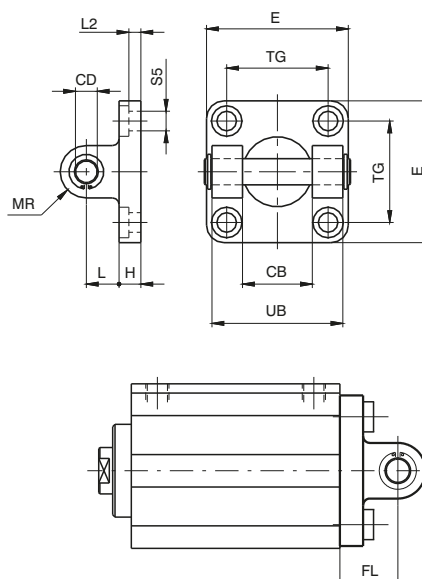

Bore	20	25	32	40	50	63	80	100
CB (h 9)	16	20	26	28	32	40	50	60
CD (H 9)	8	10	10	12	12	16	16	20
E	35	40	45	52	65	75	95	115
H	6	8	9	9	11	11	14	14
L	12	12	13	16	16	21	22	27
MR	8	9	10	12	12	16	16	20
TG	26	28	32,5	38	46,5	56,5	72	89
UB	35	40	45	52	60	70	90	110
FL	18	20	22	25	27	32	36	41
L2	/	/	5,5	5,5	6,5	6,5	10	10
S5 (H13)	5,5	6,6	6,6	6,6	9	9	11	11
Weight g	45	75	80	130	185	310	530	910

This allows anchorage of the cylinder both parallel and at a right angle to the plane; the cylinder rod can oscillate and self-align as necessary. It is made of aluminium alloy and painted black.

3 PNEUMATIC ACTUATION

**Rear clevis male**

Ordering code

**1500.Ø.09/1F**

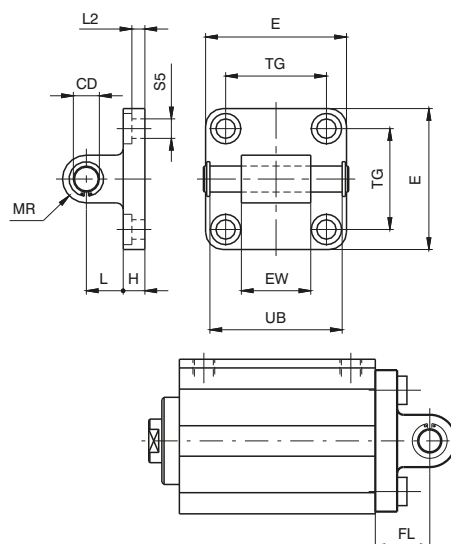

Bore	20	25	32	40	50	63	80	100
CD (h 9)	8	10	10	12	12	16	16	20
E	35	40	45	52	65	75	95	115
EW	16	20	26	28	32	40	50	60
H	6	8	9	9	11	11	14	14
L	12	12	13	16	16	21	22	27
MR	8	9	10	12	12	16	16	20
TG	26	28	32,5	38	46,5	56,5	72	89
UB	35	40	46	53	61	71	91	111
FL	18	20	22	25	27	32	36	41
L2	/	/	5,5	5,5	6,5	6,5	10	10
S5 (H 13)	5,5	6,6	6,6	6,6	9	9	11	11
every 10 mm Weight g	53	85	90	130	190	340	580	960

This allows anchorage of the cylinder both parallel and at a right angle to the plane; the cylinder rod can oscillate and self-align as necessary. It is made of aluminium alloy and painted black.

► Slot fixing screws

Ordering code
<b>1500.15F</b> (from Ø20 to Ø32)
<b>1500.16F</b> (from Ø40 to Ø63)
<b>1500.18F</b> (Ø80 and Ø100)

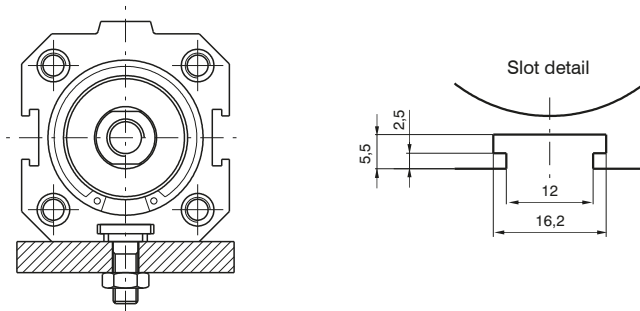
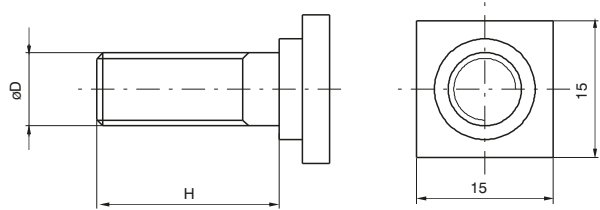

Example mounted with square headed screws on the plane.

Bore	20	25	32	40	50	63	80	100
ØD	M6	M6	M6	M8	M8	M8	M10	M10
H	15	15	15	20	20	20	25	25
Weight g		10			18			25

► Nipple with ISO standard thread

Ordering code
<b>1500.Ø.17F</b>

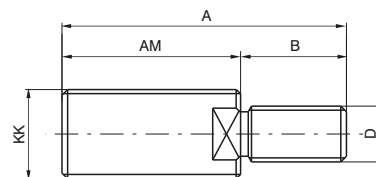

Fitted on the female thread of the compact cylinders, restore the ISO configurations rod (ISO 6432 for cylinders Ø 20 and Ø 25; ISO 6431 for cylinders from Ø 32 to Ø 100).

Bore	20	25	32	40	50	63	80	100
KK	M8x1,25	M10x1,25	M10x1,25	M12x1,25	M16x1,5	M16x1,5	M20x1,5	M20x1,5
AM	20	22	22	24	32	32	40	40
A	26	30	32	36	47	47	58	58
B	6	8	10	12	15	15	18	18
D	M4	M5	M6	M10	M12	M12	M16	M16
Weight g	8	15	16	27	65	65	110	110



## Series 1500 - "EUROPE" compact cylinders

### General

This series of cylinders is available in two versions with different threaded fixing holes.

The first one includes cylinders from Ø 32 to Ø 100 called "ISO" with fixing holes same as cylinders ISO 6431 - VDMA 24562. Cylinders from Ø 20 to Ø 100 called "UNITOP", parts of second series, are mainly according to standard UNITOP RU - P/6 - P/7. Cylinders Ø 12 and Ø 16 non standard, are interchangeable with similar products available on the market. The ISO version uses all fixing devices of series 1320 with exception of intermediate trunnion, while for cylinders Ø 12, Ø 16 and for "UNITOP" version are available fixing devices as flanges, foot, male and female clevis made with aluminium or steel. For use of magnetic sensors see directions on next page.

### Construction characteristics

Body	anodised aluminium
End caps	from Ø12 to Ø25 aluminium alloy UNI 9006/1 anodised from Ø32 to Ø100 UNI 5076 aluminium die-casting and painted (cataphoresis)
Piston rod bushing	sintered bronze
Piston rod	from Ø12 to Ø25 stainless steel from Ø32 to Ø100 C43 chromed (on request stainless steel for all bores)
Piston	from Ø12 to Ø25 plated zinc steel from Ø32 to Ø100 aluminium alloy 2011 UNI 9002/5
Seals	PUR (on request HNBR)
Spring	zinc plated steel for springs
Fixing screws	zinc plated steel

### Operational characteristics

Fluid	Filtered air. No lubrication needed, if applied it shall be continuous.
Maximum working pressure	10 bar
Working temperature	-30°C - +80°C with standard seals (magnetic or non magnetic piston) -5°C - +80°C with HNBR seals (magnetic piston) -5°C - +120°C with HNBR seals (non magnetic piston)

Please follow the suggestions below to ensure a long life for these cylinders:

- use clean and lubricated air
- correct alignment during assembly with regard to the applied load so as to avoid radial components or bending the rod.
- avoid high speeds together with long strokes and heavy loads: this would produce kinetic energy which the cylinder cannot absorb, especially if used as a limit stop (in this case use mechanical stop device)
- evaluate the environmental characteristics of cylinder used (high temperature, hard atmosphere, dust, humidity etc.)

**Please note: air must be dried for applications with lower temperature.**

Use hydraulic oils H class (ISO VG32) for correct continued lubrication.

Our Technical Department will be glad to help.

### Standard strokes for single acting cylinders

Ø12	10 mm max.
from Ø16 to Ø100	25 mm max.

### Maximum suggested strokes

Ø12 and Ø16	100 mm
Ø20 and Ø25	200 mm
Ø32 and Ø40	300 mm
Ø50 and Ø63	400 mm
Ø80 and Ø100	500 mm

*Longer strokes may be utilised if there is no radial loads on piston rod considering there isn't adjustable cushioning system.*

### Standard strokes for double acting cylinders

Ø12 and Ø16	from 5 to 40mm every 5mm
Ø20 and Ø25	from 5 to 50mm every 5mm
Ø32 - Ø100	from 5 to 80mm every 5mm

### Maximum suggested strokes with non-rotating device

from Ø12 to Ø25	40 mm
from Ø32 to Ø100	80 mm

### Minimum and maximum springs load

Bore	12	16	20	25	32	40	50	63	80	100
Min. load (N)	3,9	4,4	4,9	9,8	12,3	16,7	27,5	37,3	59,4	101,3
Max. load (N)	9,3	17,7	18,1	25,5	34,3	44,1	51,0	63,8	99,4	141,9

► BASIC version double and single acting



for bores from  $\varnothing$  12 to  $\varnothing$  25  
use sensors codes  
1580\_., MHS\_., MRS\_.\_ only

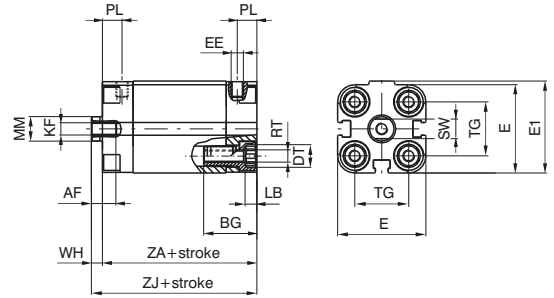
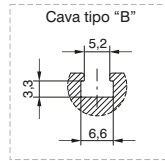

for bores from  $\varnothing$  32 to  $\varnothing$  50  
use sensors codes  
1500\_., RS\_., HS\_.\_ (slot A)  
1580\_., MHS\_., MRS\_.\_  
(slot B and slot A with adapter code 1380.01F)

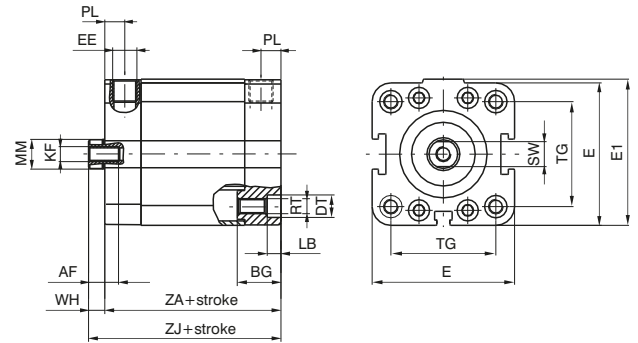
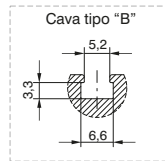
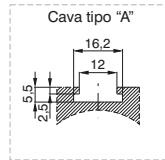

for bores from  $\varnothing$  63 to  $\varnothing$  100  
use sensors codes  
1500\_., RS\_., HS\_.\_ and  
1580\_., MHS\_., MRS\_.\_  
(with adapter code 1380.01F)

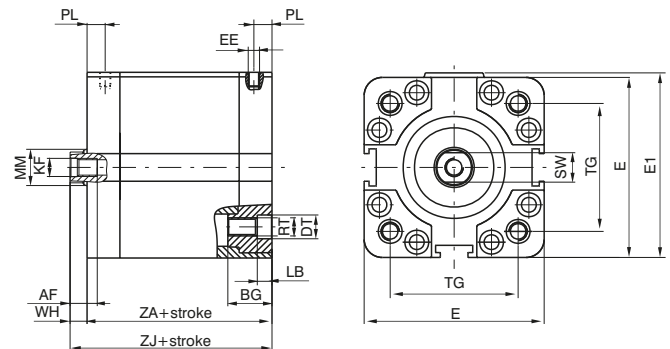
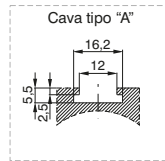

► Through rod cylinder version double and single acting

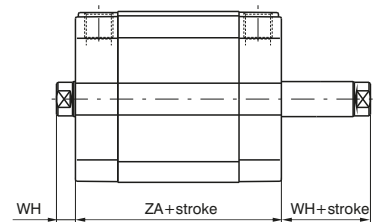

► Tandem with opposite rods

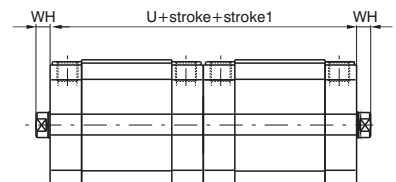

► Tandem push with common rods

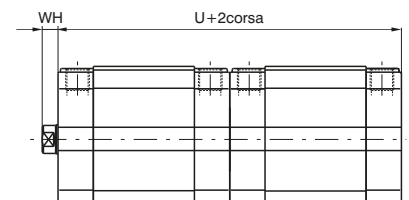

**Opposed tandem with common rod**

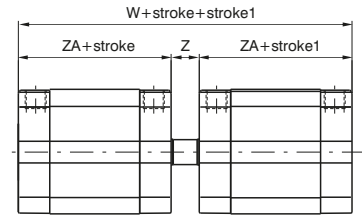

**Tandem push with independent rods**

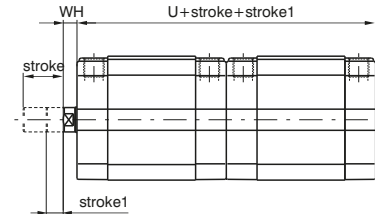

**Ordering code**

**Basic version, through rod cylinder**

- 15 . Ø . stroke . . . . .
- 1 = Double acting (magnetic)
  - 2 = Front spring (magnetic)
  - 3 = Rear spring (magnetic)
  - 4 = Double acting (non magnetic)
  - 5 = Front spring (non magnetic)
  - 6 = Rear spring (non magnetic)
- 01 = Basic version - female piston rod
  - 02 = Basic version - male piston rod
  - 03 = Through rod version - female piston rod
  - 04 = Through rod version - male piston rod
  - 05 = Through rod version - bored male piston rod
  - 06 = Through rod version - bored female piston rod
  - 07 = Non - rotating version
  - 08 = Through rod version with non rotating device on one side - female piston rod \*
  - 09 = Through rod version with non rotating device on one side - male piston rod \*
- 1 = Chromed rod C43 (from Ø12 to Ø25 stainless steel)
  - 2 = Stainless steel rod (from Ø32 to Ø100)
- 6 = ISO (Ø32 - Ø100)
  - 7 = ISO HNBR (Ø32 - Ø100)
  - 8 = UNITOP (Ø12 - Ø100)
  - 9 = UNITOP HNBR (Ø12 - Ø100)
- \* for single acting version, the spring is on the anti-rotation side

**Tandem version**

- 15 . Ø . stroke .(stroke1) . . . . .
- A = Tandem with opposite rods female thread
  - E = Tandem with opposite rods male thread
  - L = Tandem opposite rods with non rotating device on both sides
  - C = Tandem push with common rods female thread
  - G = Tandem push with common rods male thread
  - H = Tandem push with common rods, push-pull version rod female threads
  - N = Tandem push with common rods with non rotating device
  - D = Opposed tandem with common rod
  - B = Tandem push with independent rods female thread
  - F = Tandem push with independent rods male thread
  - M = Tandem push with independent rods with non rotating device
  - P = Tandem through rod with independent rods - female thread
  - Q = Tandem through rod with independent rods - male thread
- 1 = Chromed rod C43 (from Ø12 to Ø25 stainless steel)
  - 2 = Stainless steel rod (from Ø32 to Ø100)
- 6 = ISO (Ø32 - Ø100)
  - 7 = ISO HNBR (Ø32 - Ø100)
  - 8 = UNITOP (Ø12 - Ø100)
  - 9 = UNITOP HNBR (Ø12 - Ø100)

**Table of dimensions**

Bore	12	16	20	25	32	40	50	63	80	100	
AF	6	8	10	10	12	12	12	12	16	20	
BG	19	19	20	20	17,5	17,5	19,5	19,5	23,5	24,5	
DT	6	6	8	8	10	9	10,5	10,5	14	14	
E	29	29	36	40	48	57	67	80	102	122	
E1	30	30	37,5	41,5	49,5	58,5	69	82	105	125	
EE	M 5	M 5	M 5	M 5	G 1/8"	G 1/8"	G 1/8"	G 1/8"	G 1/8"	G 1/4"	
KF	M 3	M 4	M 5	M 5	M 6	M 6	M 8	M 8	M 10	M12	
LB	3,5	3,5	4,8	4,8	5,5	5,5	6,5	6,5	8,5	8,5	
MM	6	8	10	10	12	12	16	16	20	25	
PL	8	8	8	8	8	8	8	8	8,5	10,5	
RT	M 4	M 4	M 5	M 5	M 6	M 6	M 8	M 8	M 10	M 10	
SW	5	7	8	8	10	10	13	13	17	22	
TG ISO	/	/	/	/	32,5	38	46,5	56,5	72	89	
TG UNITOP	18	18	22	26	32	42	50	62	82	103	
U	76	76	76	79	89	91	91	100	112	133	
W	85	85	85	90	101	104	106	115	128	153	
WH	4,5	4,5	4,5	5,5	6	6,5	7,5	7,5	8	10	
Z	9	9	9	11	12	13	15	15	16	20	
ZA *	38	38	38	39,5	44,5	45,5	45,5	50	56	66,5	
ZJ *	42,5	42,5	42,5	45	50,5	52	53	57,5	64	76,5	
Weight	stroke 0	88	90	140	170	210	320	460	690	1390	2290
	g every 5 mm	8	8	12	13	15	19	25	31	50	66

\* These dimensions increase of 10 mm for cylinders ø 12 front spring version.

Tabular weights above refer to Basic Versions. The weights of Tandem versions are approximately double those shown.

PNEUMATIC ACTUATION 3

► Basic version male piston rod

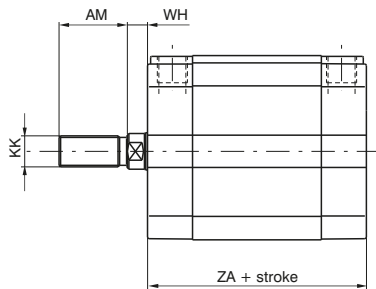

► Through rod cylinder version, male rod

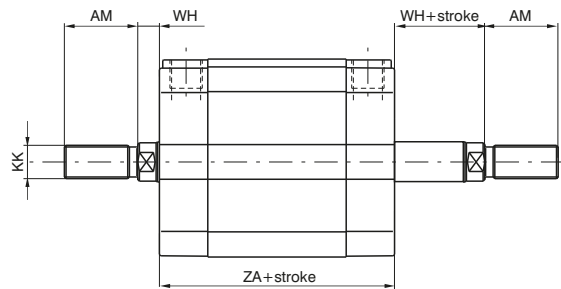

► Through rod cylinder version, bored male piston rod

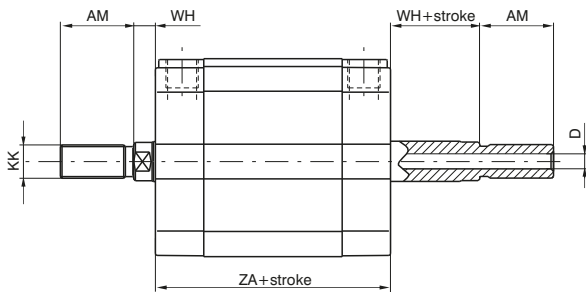

► Through rod cylinder version, bored female piston rod

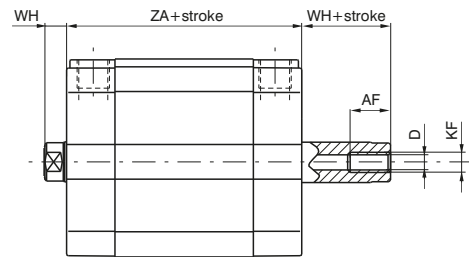

Maximum allowed stroke = ZB (see table)

► Non-rotating version

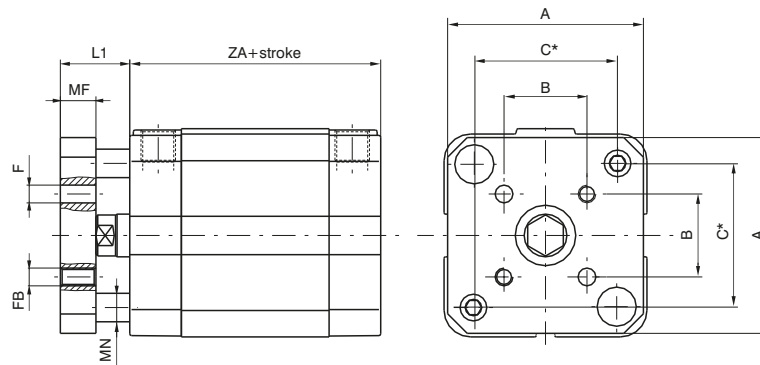

\* = Distance between rods centres

Bore	12	16	20	25	32	40	50	63	80	100
A	28,5	28,5	35,5	39,5	45	55	65	80	100	120
AF	6	8	10	10	12	12	12	12	16	20
AM	16	20	22	22	22	22	24	24	32	40
B	9,9	9,9	12	15,6	19,8	23,3	29,7	35,4	46	56,6
C	18	18	22	26	34	40,5	49	59,5	77	94
D	2,3	3,2	3,8	3,8	4,5	4,5	6	6	8	10
F	3	3	4	5	5	5	6	6	8	10
FB	M 3	M 3	M 4	M 5	M 5	M 5	M 6	M 6	M 8	M 10
KF	M 3	M 4	M 5	M 5	M 6	M 6	M 8	M 8	M 10	M 12
KK	M6X1	M8X1,25	M10X1,25	M10X1,25	M10X1,25	M10X1,25	M12X1,25	M12X1,25	M16X1,5	M20X1,5
L1	10,5	10,5	12,5	13,5	16	16,5	19,5	19,5	22	24
MF	6	6	8	8	10	10	12	12	14	14
MN	5	5	6	6	8	8	10	10	12	12
WH	4,5	4,5	4,5	5,5	6	6,5	7,5	7,5	8	10
ZA	38	38	38	39,5	44,5	45,5	45,5	50	56	66,5
ZB	20	25	50	50	50	50	75	75	80	80

**Front and rear flanges**

Ordering code

ISO  
**1500.Ø.03F**  
steel

UNITOP  
**1580.Ø.03F**  
steel

**1580.Ø.03/1F**  
aluminium

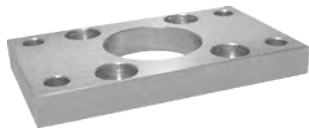
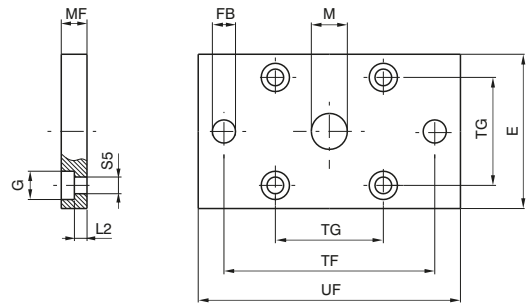

For bores from 12 to 25

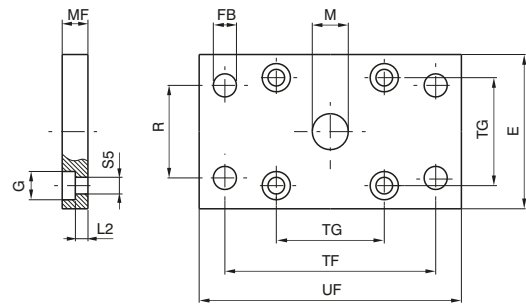

For bores from 32 to 100

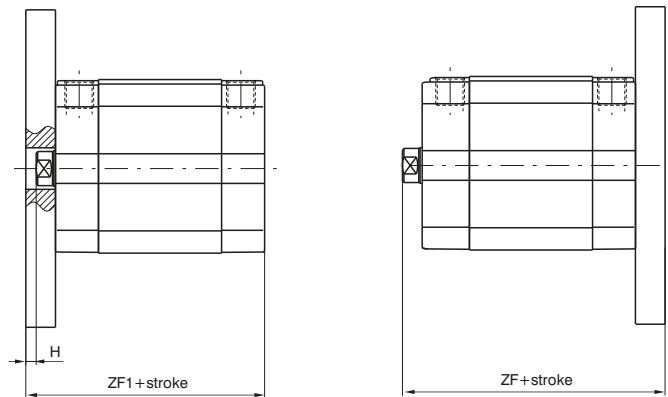

Front

Rear

Plate which allows anchorage of the cylinder at a right angle to the plane. It is made with zinc-plated extruded steel or with aluminium.

	ISO Dimensions						UNITOP Dimensions									
	32	40	50	63	80	100	12-16	20	25	32	40	50	63	80	100	
Bore	32	40	50	63	80	100	12-16	20	25	32	40	50	63	80	100	
E	45	52	65	75	95	115	29	36	40	50	60	68	87	107	128	
S5 (H13)	6,6	6,6	9	9	11	11	4,5	5,5	5,5	6,6	6,6	9	9	11	11	
FB(H13)	7	9	9	9	12	14	5,5	6,6	6,6	7	9	9	9	12	14	
G	10,5	11	15	15	18	18	9	10	10	11	11	15	15	18	18	
H	4	3,5	4,5	4,5	8	6	5,5	5,5	4,5	4	3,5	4,5	7,5	7	5	
L2	5	5	6,5	6,5	8	8	4,6	4,6	4,6	3,6	3,6	3,4	6,4	4,4	4,4	
M(H11)	30	35	40	45	45	55	10	12	12	14	14	18	18	23	28	
MF(JS14)	10	10	12	12	16	16	10	10	10	10	10	12	15	15	15	
R(JS14)	32	36	45	50	63	75	/	/	/	32	36	45	50	63	75	
TF(JS14)	64	72	90	100	126	150	43	55	60	65	82	90	110	135	163	
TG	32,5	38	46,5	56,5	72	89	18	22	26	32	42	50	62	82	103	
UF	80	90	110	120	150	170	55	70	76	80	102	110	130	160	190	
ZF	60,5	62	65	69,5	80	92,5	52,5	52,5	55	60,5	62	65	72,5	79	91,5	
ZF1	54,5	55,5	57,5	62	72	82,5	48	48	49,5	54,5	55,5	57,5	65	71	81,5	
Weight	Steel		160	250	480	620	1430	1970	100	170	210	270	430	600	1210	2610
g	Aluminium		/	/	/	/	/	/	35	60	70	90	150	210	420	900



Foot

Ordering code  
**ISO**  
**1500.Ø.05/1F**  
(1 piece)  
**UNITOP**  
**1580.Ø.05/1F**  
(1 piece)

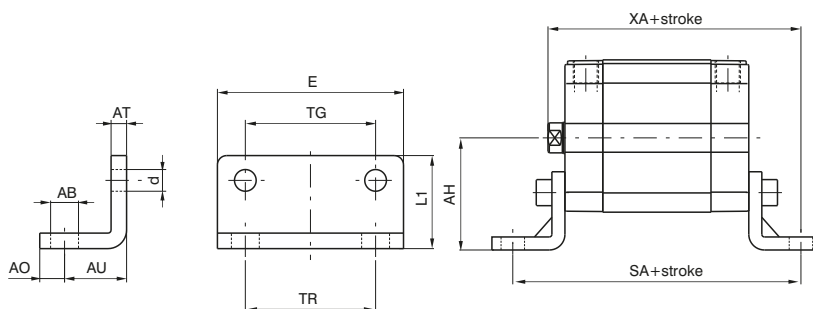

Element used to anchor the cylinder parallel to the mounting plane. They are made with stamped and pierced sheet metal black painted.

	ISO Dimensions							UNITOP Dimensions								
Bore	32	40	50	63	80	100	12-16	20	25	32	40	50	63	80	100	
AB (H14)	7	9	9	9	12	14	5,5	6,6	6,6	6,6	9	9	11	11	13,5	
AH (JS15)	32	36	45	50	63	71	22	27	30	32	42,5	47	59,5	65,5	78	
AO (±0,2)	11	8	15	13	14	16	4,5	6	6	8	8	8	12	12	12	
AT	4	4	5	5	6	6	3	4	4	5	5	6	6	8	8	
AU (±0,2)	24	28	32	32	41	41	13	16	16	18	20	24	27	30	33	
d	7	7	9	9	11	11	4,4	5,4	5,4	6,6	6,6	9	9	11	11	
E	45	52	65	75	95	115	30	36	40	50	60	68	84	102	123	
L1	30	30	36	35	47	53	17,5	22	23	24	29,5	30	39	36,5	38,5	
SA	92,5	101,5	109,5	114	138	148,5	64	70	71,5	80,5	85,5	93,5	104	116	132,5	
TG	32,5	38	46,5	56,5	72	89	18	22	26	32	42	50	62	82	103	
TR	32	36	45	50	63	75	18	22	26	32	42	50	62	82	103	
XA	74,5	80	85	89,5	105	117,5	55,5	58,5	61	68,5	72	77	84,5	94	109,5	
Weight g	50	70	120	180	320	400	20	35	45	75	100	150	250	390	500	

UNITOP rear male clevis for bores from 12 to 25

Ordering code  
**1580.Ø.09/1F (Aluminium)**  
**1580.Ø.09/2F (Steel)**

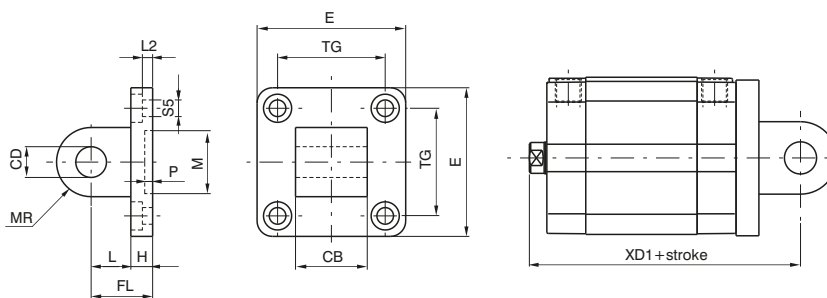

This type of mounting allows anchorage of the cylinder both parallel and at the right angle to the plane. The cylinder rod can oscillate and self-align to the connected load. It's made with aluminium alloy black painted or with zinc plated steel (from Ø 20).

Bore	12-16	20	25	
CB(h14)	12	16	16	
CD (H9)	6	8	8	
E (±0,5)	27	34	38	
FL	16	20	20	
H	6	6	6	
L	10	14	14	
L2 (±0,5)	2,6	2,6	2,6	
M (H11)	10	12	12	
MR	6	8	8	
P (+0,3)	3	3	3	
S5 (H13)	4,5	5,5	5,5	
TG (±0,2)	18	22	26	
XD1	58,5	62,5	65	
Weight g	Steel	/	70	80
	Aluminium	13	25	28

**Front female clevis for bores from 32 to 100**

Ordering code
ISO Aluminium <b>1500.Ø.08F</b>
UNITOP (Aluminium) <b>1580.Ø.11F</b>
UNITOP (Steel) <b>1580.Ø.13F</b>

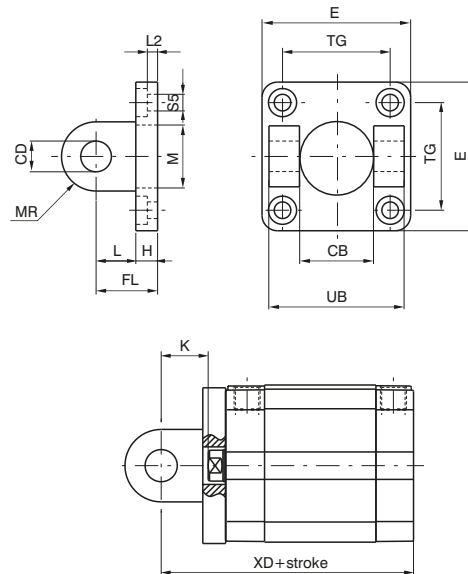

This type of mounting allows anchorage of the cylinder both parallel and at the right angle to the plane. The cylinder rod can oscillate and self-align to the connected load. It's made with aluminium alloy black painted or with zinc plated steel.

3

PNEUMATIC ACTUATION

**Rear female clevis for bores from 32 to 100**

Ordering code
ISO Aluminium <b>1500.Ø.09F</b>
UNITOP (Aluminium) <b>1580.Ø.10F</b>
UNITOP (Steel) <b>1580.Ø.12F</b>

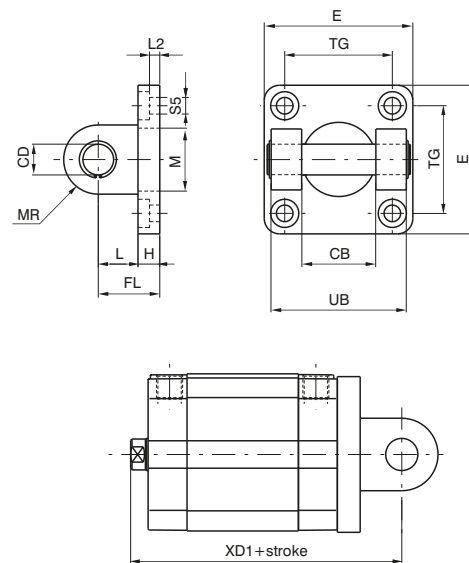

This type of mounting allows anchorage of the cylinder both parallel and at the right angle to the plane. The cylinder rod can oscillate and self-align to the connected load. It's made with aluminium alloy black painted or with zinc plated steel.

	ISO Dimensions						UNITOP Dimensions							
	32	40	50	63	80	100	32	40	50	63	80	100		
Bore	32	40	50	63	80	100	32	40	50	63	80	100		
CB (H14)	26	28	32	40	50	60	26	28	32	40	50	60		
CD (H9)	10	12	12	16	16	20	10	12	12	16	16	20		
E	45	52	65	75	95	115	48	58	66	83	102	123		
FL	22	25	27	32	36	41	22	25	27	32	36	41		
H	9	9	11	11	14	14	9	9	11	11	13	15		
K	16	18,5	19,5	24,5	28	31	16	18,5	19,5	24,5	28	31		
L	13	16	16	21	22	27	13	16	16	21	23	26		
L2	5,5	5,5	6,5	6,5	10	10	5,5	5,5	6,5	6,5	10	10		
M	30	35	40	45	45	55	14	14	18	18	23	28		
MR	10	12	12	16	16	20	10	12,5	12,5	15	15	20		
S5	6,6	6,6	9	9	11	11	6,6	6,6	9	9	11	11		
TG	32,5	38	46,5	56,5	72	89	32	42	50	62	82	103		
UB	45	52	60	70	90	110	45	52	60	70	90	110		
XD	66,5	70,5	72,5	82	92	107,5	66,5	70,5	72,5	82	92	107,5		
XD1	72,5	77	80	89,5	100	117,5	72,5	77	80	89,5	100	117,5		
Weight g	Steel	Front	/	/	/	/	/	180	310	420	700	1240	2210	
		Rear	/	/	/	/	/	220	360	480	830	1390	2500	
	Alum.	Front	40	70	120	170	360	570	65	110	145	240	430	770
		Rear	80	120	180	300	500	860	80	125	170	290	480	865

Slot fixing screws

Ordering code
<b>1500.17F</b> small slot (from Ø12 to Ø50)
<b>1500.15F</b> large slot (Ø32)
<b>1500.16F</b> large slot (from Ø40 to Ø63)
<b>1500.18F</b> large slot (from Ø80 to Ø100)

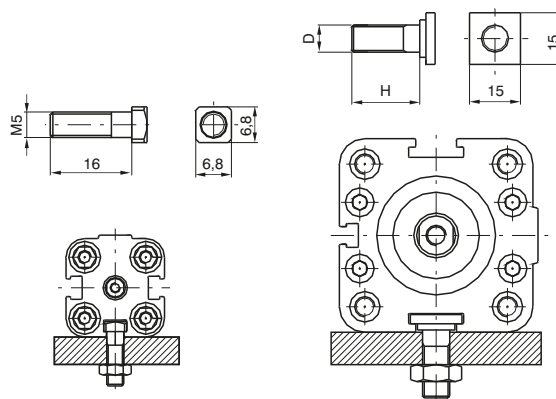
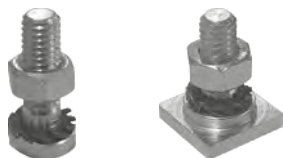

Example of mounting with square head screws

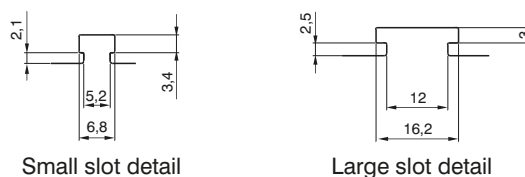

Bore	12÷50	32	40÷63	80÷100
D	/	M6	M8	M10
H	/	15	20	25
Weight g	8	10	18	25

Centering rings

Ordering code
<b>1580.Ø.02F</b>

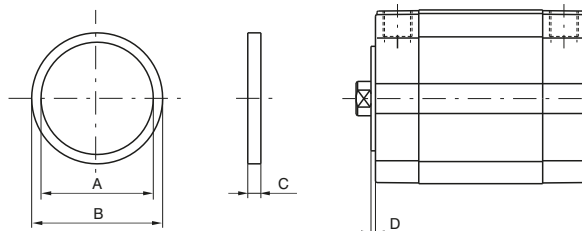

This aluminium ring allows the center assembling of the cylinder.

Bore	32	40	50	63	80	100
A	25	30	35	40	40	50
B (e11)	30	35	40	45	45	55
C	3,5	3,5	3,5	4,5	5,5	5,5
D	1,5	1,5	1,5	2	2,5	2,5
Weight g	2	2	3	4	5	6

Sensor adapter

Ordering code
<b>1380.01F</b>



Weight g 2

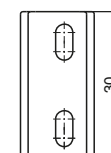
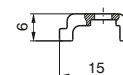

Nylon accessory for sensor mounting 1580.\_, MRS.\_, MHS.\_ inside "A" shape.



## Series 1500 - Compact cylinders ECOMPACT-S

### General

Based on the **ECOMPACT** series with piston rods and centring diameters according to ISO 15552 standard.

### Construction characteristics

Body	anodised aluminium
End caps	aluminium alloy casting painted with brass centring bearing
Bearing piston rod	spheroid bronze on steel band with P.T.F.E. coat
Piston rod	C43 chromed steel (on request stainless steel)
Piston	Ø32 and Ø40 acetal resin (aluminium on request) Ø50 and Ø63 aluminium (with FPM seals, aluminium for all of standard diameters)
Seals	standard: NBR oil resistant rubber, PUR piston rod seals (PUR or FPM on request)
Spring	stainless steel
Fixing screws	plated zinc steel

### Operational characteristics

Fluid	Filtered air. No lubrication needed, if applied it shall be continuous
Max. pressure	10 bar
Operating temperature	-5°C - +70°C with standard seals (magnetic or non magnetic piston) -30°C - +80°C with PUR seals (magnetic or non magnetic piston) -5°C - +80°C with FPM seals (magnetic piston) -5°C - +150°C with FPM seals (non magnetic piston)

Please follow the suggestions below to ensure a long life for these cylinders:

- use clean and lubricated air
- correct alignment during assembly with regard to the applied load so as to avoid radial components or bending the rod.
- avoid high speeds together with long strokes and heavy loads: this would produce kinetic energy which the cylinder cannot absorb, especially if used as a limit stop (in this case use mechanical stop device and aluminium piston)
- evaluate the environmental characteristics of cylinder used (high temperature, hard atmosphere, dust, humidity etc.)

**Please note: air must be dried for applications with lower temperature.**

Use hydraulic oils H class (ISO VG32) for correct continued lubrication.

Our Technical Department will be glad to help.

### Stroke tolerance, minimum and maximum spring loads and cushioning length

Bore (mm)	Stroke tolerance (mm)	Minimum and maximum spring load (N)		Cushioning length (mm)
		min.	max.	
Ø32	+2 / 0 mm	19,6	25,5	6,5
Ø40		25,5	42,2	8
Ø50		44,1	96,3	7,5
Ø63	+2,5 / 0 mm	44,1	96,3	7,5

Standard stroke

DOUBLE ACTING  
BASIC and  
THROUGH ROD CYLINDER version

Bore	Stroke																												
	5	10	15	20	25	30	35	40	45	50	55	60	65	70	75	80	100	125	150	160	200	250	300	320	350	400	450	500	
	<b>WITHOUT CUSHIONING DEVICE</b>																												
Ø32	●	●	●	●	●	●	●	●	●	●	●	●	●	●	●	●	●	●	●	●	●	●	●	●	●	●	●	●	●
Ø40	●	●	●	●	●	●	●	●	●	●	●	●	●	●	●	●	●	●	●	●	●	●	●	●	●	●	●	●	●
Ø50	●	●	●	●	●	●	●	●	●	●	●	●	●	●	●	●	●	●	●	●	●	●	●	●	●	●	●	●	●
Ø63	●	●	●	●	●	●	●	●	●	●	●	●	●	●	●	●	●	●	●	●	●	●	●	●	●	●	●	●	●
	<b>WITH CUSHIONING DEVICE</b>																												
Ø32					●	●	●	●	●	●	●	●	●	●	●	●	●	●	●	●	●	●	●	●	●	●	●	●	●
Ø40					●	●	●	●	●	●	●	●	●	●	●	●	●	●	●	●	●	●	●	●	●	●	●	●	●
Ø50					●	●	●	●	●	●	●	●	●	●	●	●	●	●	●	●	●	●	●	●	●	●	●	●	●
Ø63					●	●	●	●	●	●	●	●	●	●	●	●	●	●	●	●	●	●	●	●	●	●	●	●	●

DOUBLE ACTING  
THROUGH ROD CYLINDER  
BORED version

Bore	Stroke																												
	5	10	15	20	25	30	35	40	45	50	55	60	65	70	75	80													
	<b>WITHOUT CUSHIONING DEVICE</b>								<b>WITH CUSHIONING DEVICE</b>																				
Ø32	●	●	●	●	●	●	●	●									●	●	●	●	●	●							
Ø40	●	●	●	●	●	●	●	●	●								●	●	●	●	●	●							
Ø50	●	●	●	●	●	●	●	●	●	●	●	●	●	●	●	●	●	●	●	●	●	●	●	●	●	●	●	●	●
Ø63	●	●	●	●	●	●	●	●	●	●	●	●	●	●	●	●	●	●	●	●	●	●	●	●	●	●	●	●	●

Available versions

BASIC version

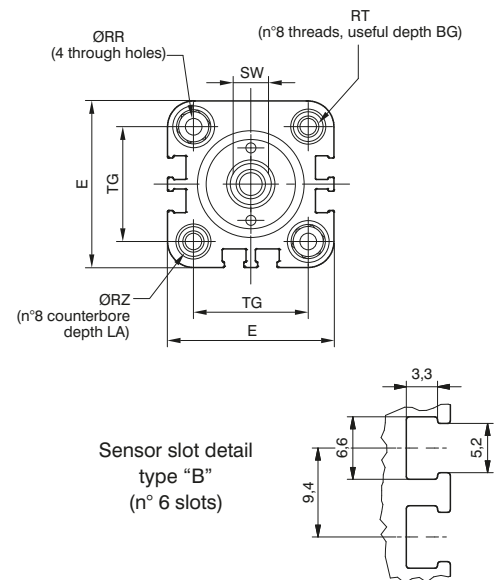
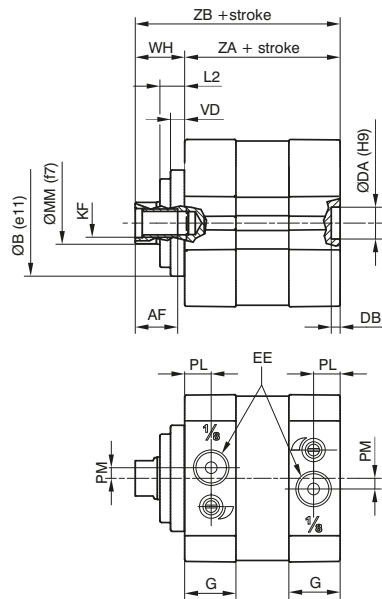

THROUGH ROD CYLINDER version

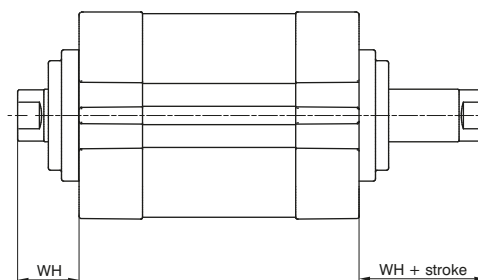

**Ordering codes**

- 15** .Ø.stroke.
- 0=NBR seals and C43 chromed plated rod
  - 1=NBR seals and stainless steel rod
  - 4= PUR seals and C43 chromed plated rod
  - 5= PUR seals and stainless steel rod
  - 6= FPM seals and C43 chromed plated rod
  - 7= FPM seals and stainless steel rod
- 4= Non-cushioned version (mechanical cushioning only)
- 5= Versions with adjustable end of stroke cushioning system
- 1= Double acting, magnetic piston
  - 4= Double acting, non magnetic piston
  - 10= Basic, female threaded rod
  - 11= Basic, male threaded rod
  - 12= through rod, female threaded rod
  - 13= through rod, male threaded rod
  - 14= through rod, bored female threaded rod
  - 15= through rod, bored male threaded rod
- \*\* It is possible to order the Ø32 and Ø40 cylinders with an aluminium piston by replacing the '1' with '2' in the ordering code.  
Example: 1540.32.10.10.1 (Acetyl Resin Piston)  
1540.32.10.20.1 (Aluminium Piston version)

**Seals compounds scheme**

- NBR:** oil resistant nitrilic rubber seals  
**PUR:** polyurethane seals  
**FPM:** fluoropolymer rubber seals

**Table of dimensions**

Bore	Ø32	Ø40	Ø50	Ø63
AF (min)	12	16	20	20
ØB (e11)	30	35	40	45
BG	16	16	16	16
ØDA (H9)	9	9	12	12
DB (+0,1/0)	2,5	2,5	2,6	2,6
E (max)	47,5	55	66	78
EE	G1/8"	G1/8"	G1/8"	G1/8"
G	14,5	15	15	15
KF	M8	M10	M12	M12
LA (0/-0,1)	5	5	5	5
L2	7	7	10	10
ØMM (f 7)	12	16	20	20
PL (+0,1/0)	7,5	8	8	8
PM	3	/	/	/
ØRR (min)	5,1	5,1	6,6	6,6
RT	M6	M6	M8	M8
ØRZ (min)	8,5	8,5	10,5	10,5
SW (0/-0,1)	10	13	17	17
TG (±0,2)	32,5	38	46,5	56,5
VD	4	4	5	5
WH (±1)	14	14	18	18
ZA (±0,5)	44	45	45	49
ZB (+1/0)	58	59	63	67
Weight stroke	240	330	530	700
gr. every 5mm	13	17	24	27

**Basic version male piston rod**

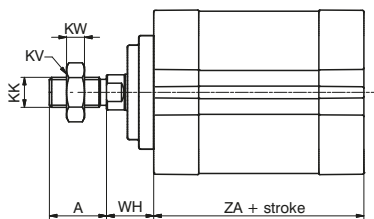

**Through rod version male rod**

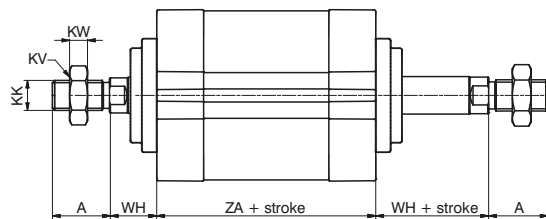

**Through rod version bored female piston rod**

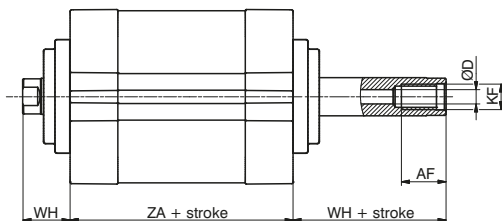

**Through rod version bored male piston rod**

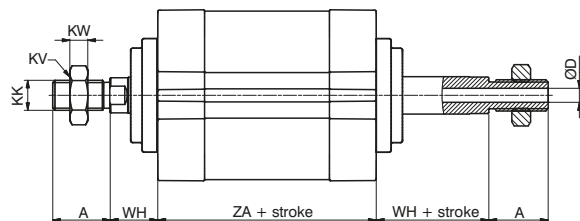

Bore	A (0/-0,5)	AF (min)	ØD	KF	KK	KV	KW	WH (±1)	ZA (±0,5)
Ø32	22	14	4,5	M8	M10x1,25	17	6	14	44
Ø40	24	18	4,5	M10	M12x1,25	19	7	14	45
Ø50	32	24	6	M12	M16x1,5	24	8	18	45
Ø63	32	24	6	M12	M16x1,5	24	8	18	49

Sensor and piston rod accessories

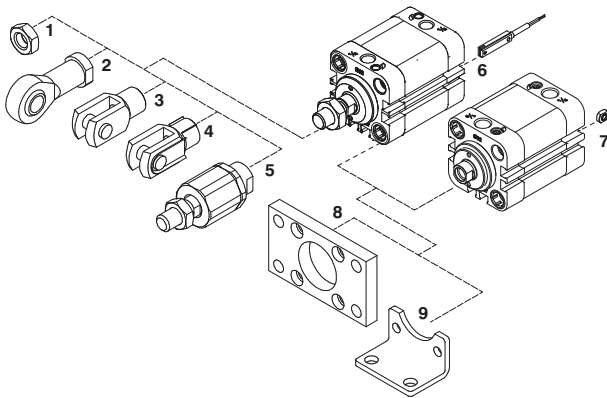

Pos.	Description	Ordering code	
1	Rod lock nut	1320.32.18F	(Ø32)
		1320.40.18F	(Ø40)
		1320.50.18F	(Ø50-Ø63)
2	Ball joint	1320.32.32F	(Ø32)
		1320.40.32F	(Ø40)
		1320.50.32F	(Ø50-Ø63)
3	Fork	1320.32.13F	(Ø32)
		1320.40.13F	(Ø40)
		1320.50.13F	(Ø50-Ø63)
4	Fork with clips	1320.32.13/1F	(Ø32)
		1320.40.13/1F	(Ø40)
		1320.50.13/1F	(Ø50-Ø63)
5	Self aligning joint	1320.32.33F	(Ø32)
		1320.40.33F	(Ø40)
		1320.50.33F	(Ø50-Ø63)
6	Sensors	(See chapter 6 magnetic sensor)	
7	Valves direct mounting bolt	1500.20F	(Ø32 - Ø63)

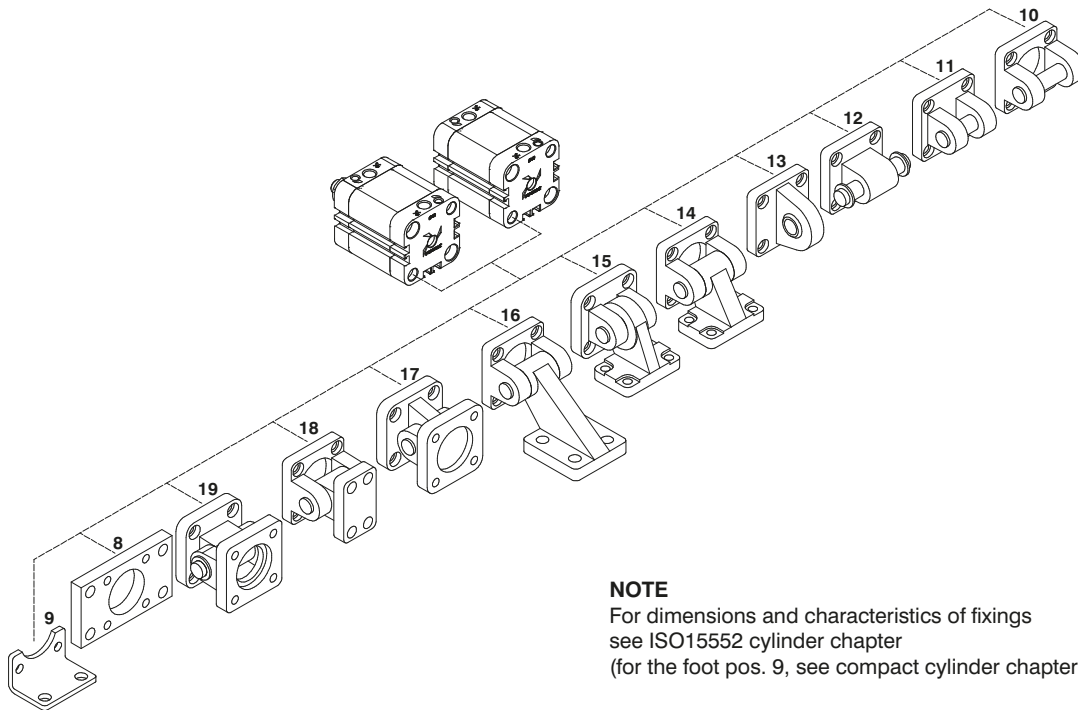

**NOTE**

For dimensions and characteristics of fixings see ISO15552 cylinder chapter (for the foot pos. 9, see compact cylinder chapter ISO 21287).

**Fixing**

Pos.	Description	Ordering code	
		Aluminium	Steel
8	Flange (MF2)	1390.Ø.03FP	1380.Ø.03F
9	Foot (MS1)	/	1540.Ø.05/1F
10	Rear female clevis (MP2)	1380.Ø.09F	1320.Ø.20F
11	Narrow rear female clevis (AB6)	1380.Ø.30F	1320.Ø.29F
12	Rear male clevis (MP4)	1380.Ø.09/1F	1320.Ø.21F
13	Rear male clevis (with jointed head - MP6)	1380.Ø.15F	1320.Ø.25F
14	Square angle trunnion (Ab7)	1380.Ø.35F	1320.Ø.23F
15	Square angle trunnion (with jointed head)	/	1320.Ø.27F
16	Square angle trunnion (not specified by ISO 15552)	1380.Ø.11F	/
17	Standard trunnion (with jointed head)	1380.Ø.36F	1320.Ø.26F
18	Standard trunnion (not specified by ISO 15552)	1380.Ø.10F	/
19	Complete standard trunnion	1380.Ø.22F	1320.Ø.22F

Admissible maximum radial load diagram

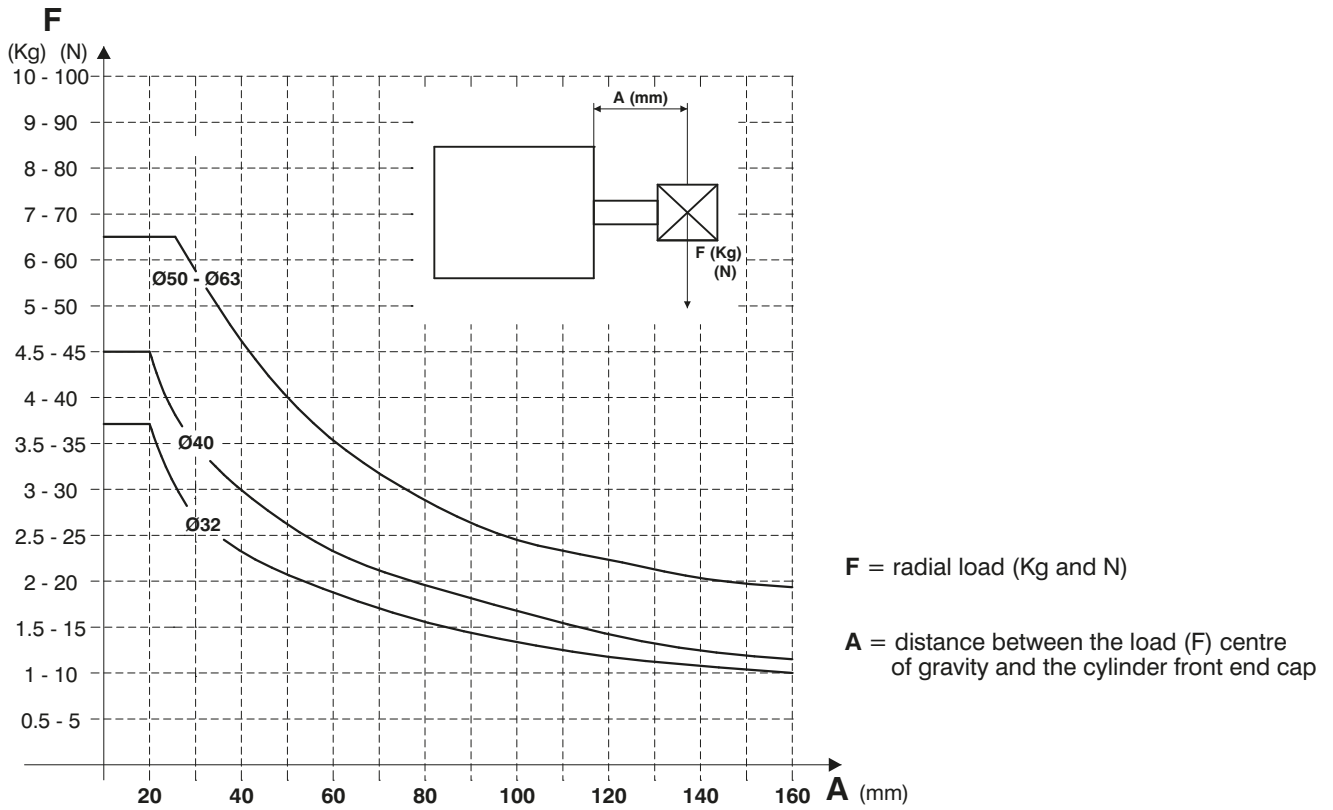

The diagram shows the maximum radial load  $F$  (in Newtons) that can be applied to the cylinder piston rod as a function of the distance  $A$  (in mm), under static conditions

End of stroke cushioning capacity diagram

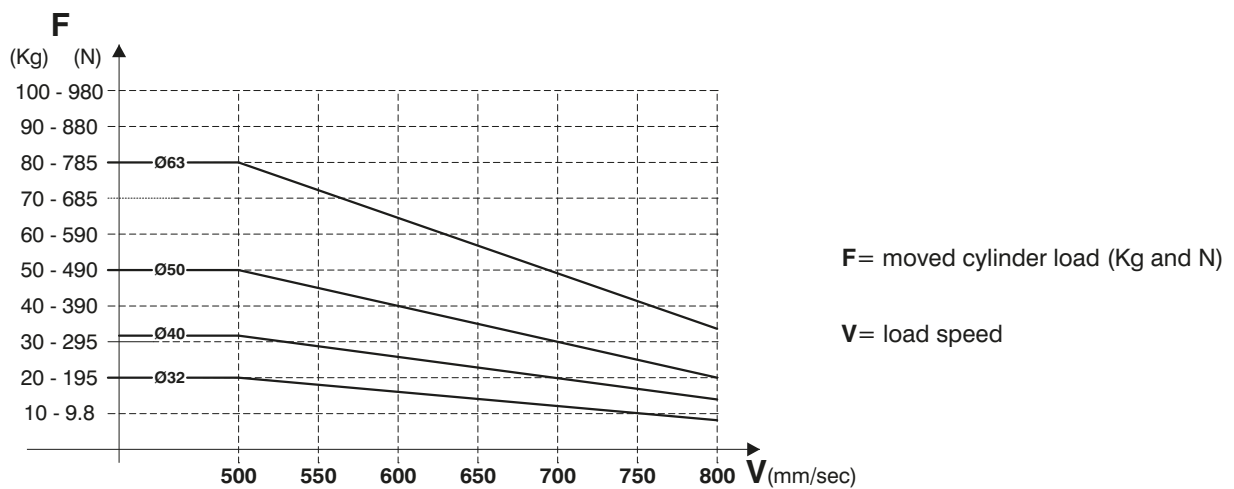

The diagram shows, for each diameter, the safety curves relative to the maximum loads which can be moved by the cylinder in function of its speed  $V$ . The data has been calculated under the following test conditions: Cylinder mounted vertically with the rod pointing down, air pressure at 5 bar and with a guided load. Important: Do not exceed the recommended values in the table as reduced life or damage to the cylinder may result.

3 PNEUMATIC ACTUATION



► Multimount cylinders



Ordering code

6500.Ø.stroke. 1 .

10	= non magnetic <b>M</b> = magnetic
16	
20	
25	

Construction characteristics

Body	anodised aluminium
Piston rod	stainless steel
Piston	brass
Rods bushing	sinterize bronze
End plate	anodised aluminium
Cushioning washer	PUR
Seal	oil resistant NBR rubber

Technical characteristics

Fluid	Filtered air. No lubrication needed, if applied it shall be continuous.
Minimum working pressure	0.6 bar (for bore Ø10 - Ø16) 0.5 bar (for bore Ø20 - Ø32)
Max pressure	7 bar
Operating temperature	-5°C - +70°C
Cushioning	with elastic bumper
Stroke tolerance	+1 / 0 mm
Piston speed	50 - 500 mm/sec (without load)

Standard stroke

Bore	Stroke							
	5	10	15	20	25	30	40	50
Ø10	●	●	●	●	●	●		
Ø16	●	●	●	●	●	●		
Ø20	●	●	●	●	●	●	●	●
Ø25	●	●	●	●	●	●	●	●

Overall dimensions

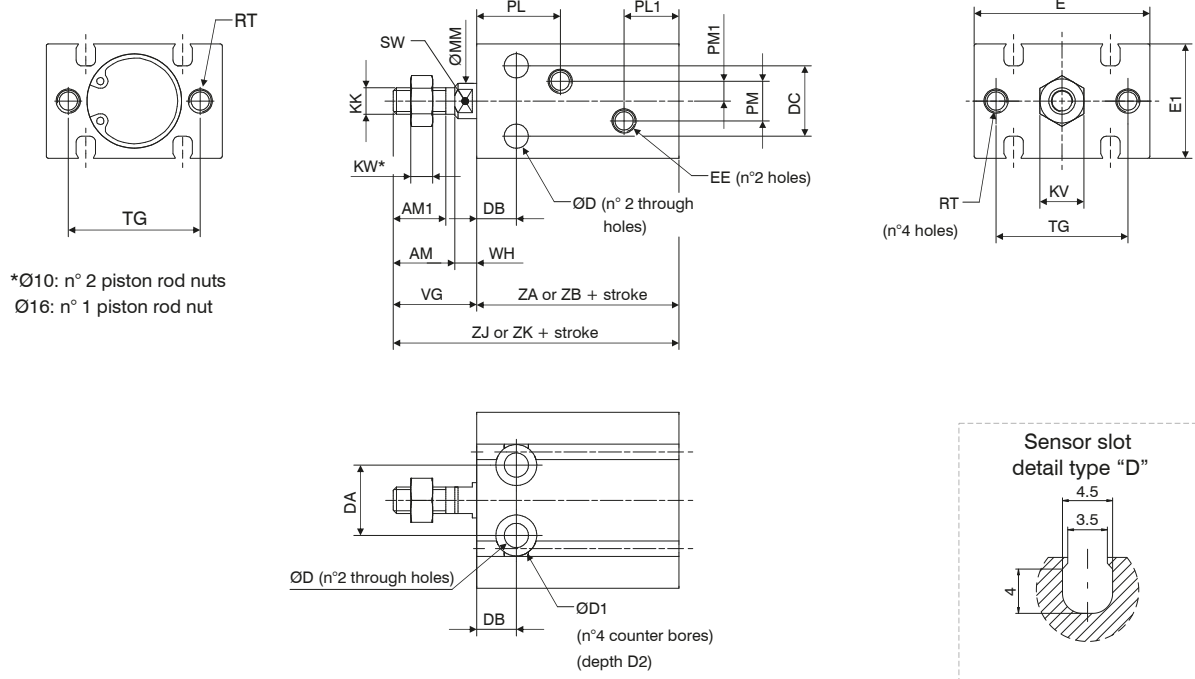
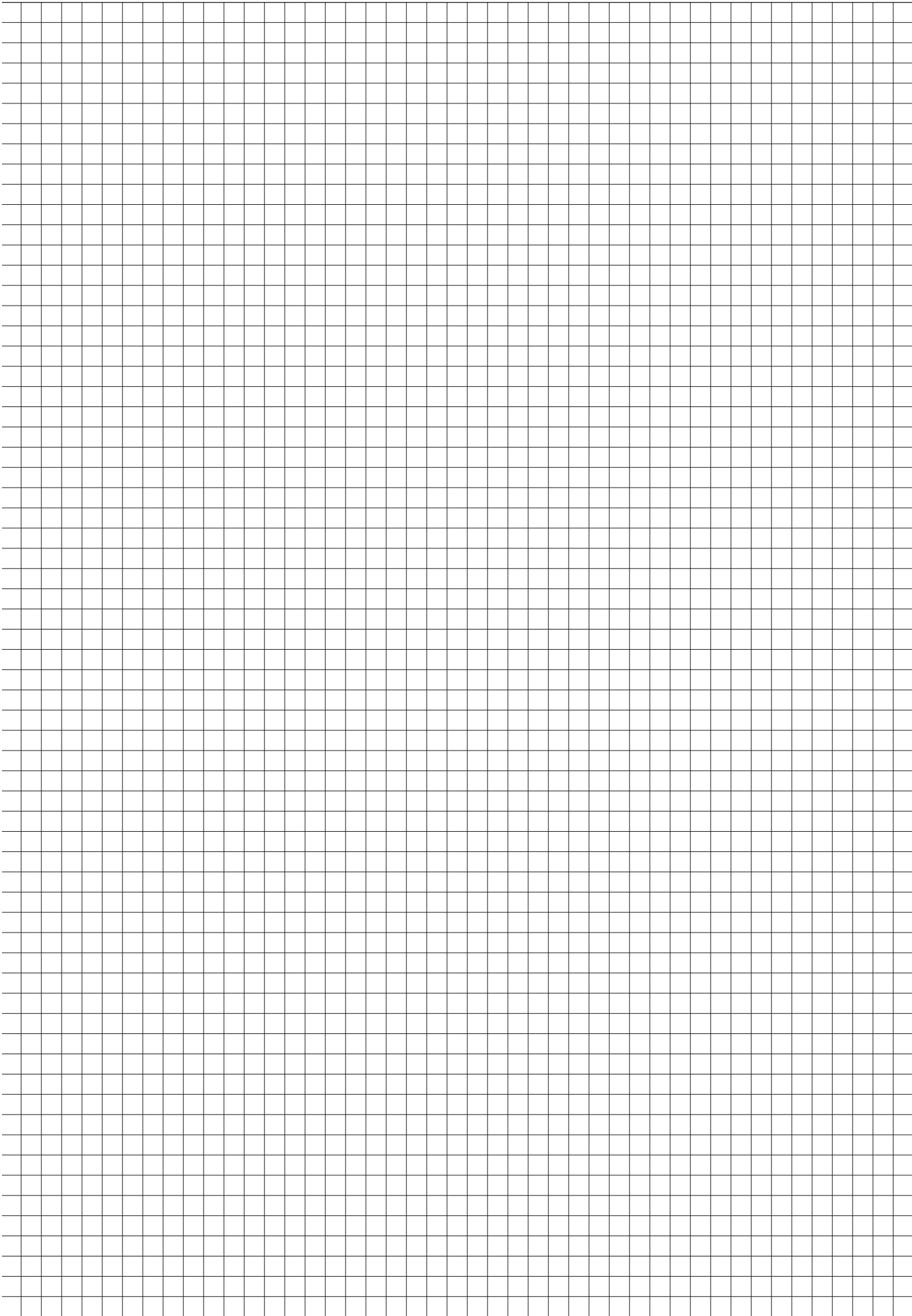
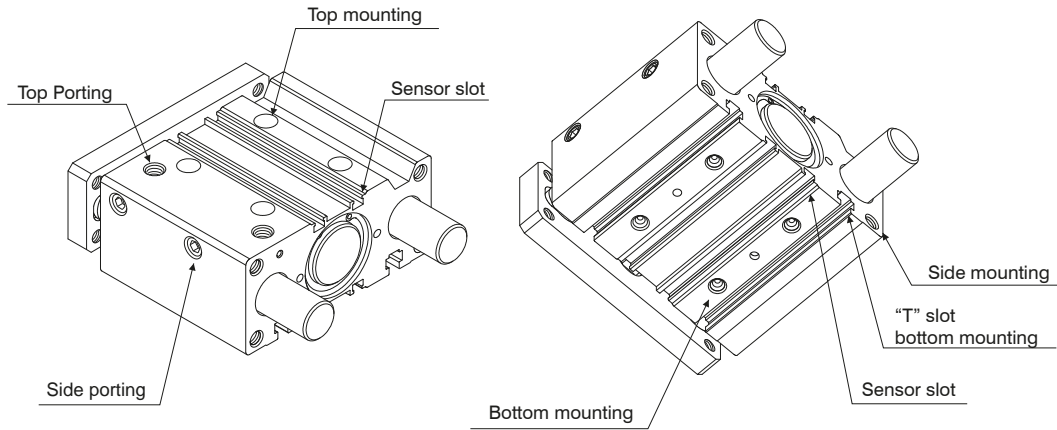

Table of dimensions

	Bore			
	Ø10	Ø16	Ø20	Ø25
AM	/	12,5	14	18
AM1	10	11	12	15,5
ØD	Ø3,2	Ø4,5	Ø5,5	Ø5,5
ØD1	Ø6	Ø7,6	Ø9,3	Ø9,3
D2	5	6,5	8	9
DA	11	14	16	20
DB	7	7	9	10
DC	9	12	16	20
E	24	32	40	50
E1	15	20	26	32
EE	M5	M5	M5	M5
KK	M4	M5	M6	M8
KV	7	8	10	13
KW	3	4	5	5
ØMM	Ø4	Ø6	Ø8	Ø10
PL	16,5	16,5	19	21,5
PL1	10	11,5	12,5	13
PM	/	4	9	9
PM1	/	2	4,5	4,5
RT	M3 (useful depth 5)	M4 (useful depth 6)	M5 (useful depth 8)	M5 (useful depth 8)
SW	/	5	6	8
TG	18	25	30	38
VG	16	16	19	23
WH	/	3,5	5	5
ZA	magnetic	36	40	46
ZB	non magnetic	36	30	36
ZJ	magnetic	52	56	65
ZK	non magnetic	52	46	55
<b>Weight (g)</b>				
Stroke 0	32	44	84	159
every 5 mm	4	6	11	17



## Series 6100 - 6101 - 6110 - Guided compact cylinder



These guided compact cylinders, characterised by reduced overall dimensions, can be used for the compression, conveyance and manipulation of objects in many industrial sectors; similarly they can also be used in pushing, lifting and stopping applications.

These cylinders are available in sizes 32mm to 63 mm diameter, and comprise a single compact cylinder with integral guide rods, making it a true guide cylinder designed with installation flexibility and space saving in mind.

The rod guide is available in two styles:

**Self-lubricating bronze bushes** - useful for absorbing lateral loads and forces, especially as a stopper.

**Bearing bushes** - guaranteeing high precision and uniform movement with low friction characteristics, useful with mis-aligned loads.

Guided compact cylinders are ideal for use in applications requiring a combination of reduced dimensions and anti-rotation features. Mounting can be achieved on three sides through holes or "T" slots.

Adjustable mounting holes in the front plate ensure safe and accurate assembly. Pneumatic connections can be made to either lateral or top ports (lateral ports plugged on standard units).

When sensors are required, there are special slots in the barrel extrusion where 1580 series miniaturised sensors are easily fitted.

► Guided compact cylinder



Ordering code

**6100.Ø.stroke.** . . .

12	}	Side supply ports closed
16		
20	}	L = Top supply ports closed
25		
32	}	B = Control unit with bronze bush
40		
50	}	C = Control unit with bearing bush
63		

Construction characteristics

Body	anodised aluminium
Guide rods	C43 chromed steel (control unit with bronze bush) tempered and chromed steel (control unit with bearing bush)
Piston	aluminium
Piston rod	stainless steel (for bores Ø12, Ø16, Ø20, Ø25) C43 chromed steel (for bores Ø32, Ø40, Ø50, Ø63)
Rods bushing	bronze or bearing bushing
End cap	anodised aluminium
Piston seal	oil resistant NBR rubber
Piston rod seal	PUR (NBR 12-16)
Wipers	PUR
Plate	nickel plated steel

Operational characteristics

Function	double acting
Fluid	Filtered air. No lubrication needed, if applied it shall be continuous.
Working pressure	max. 10 bar
Working temperature	-5°C - +70°C
Cushioning	elastic bumper on both ends

Standard stroke

Bore	Stroke											
	10	20	25	30	40	50	75	100	125	150	175	200
Ø12	●	●		●	●	●	●	●				
Ø16	●	●		●	●	●	●	●				
Ø20		●		●	●	●	●	●	●	●	●	●
Ø25		●		●	●	●	●	●	●	●	●	●
Ø32			●			●	●	●	●	●	●	●
Ø40			●			●	●	●	●	●	●	●
Ø50			●			●	●	●	●	●	●	●
Ø63			●			●	●	●	●	●	●	●

Intermediate strokes can be obtained using spacers with defined length (5, 10, 15, 20 mm).

Example: It is possible to obtain a **6100.32.45.B** cylinder from a **6100.32.50.B** cylinder by inserting a spacer with length of 5 mm. The intermediate strokes manufactured without the use of spacers are considered special executions.

Overall dimensions

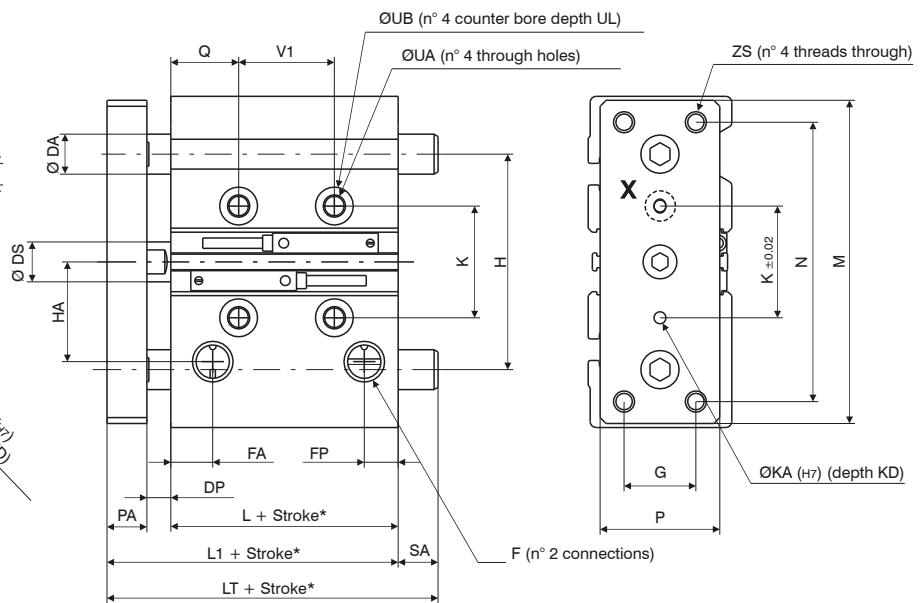
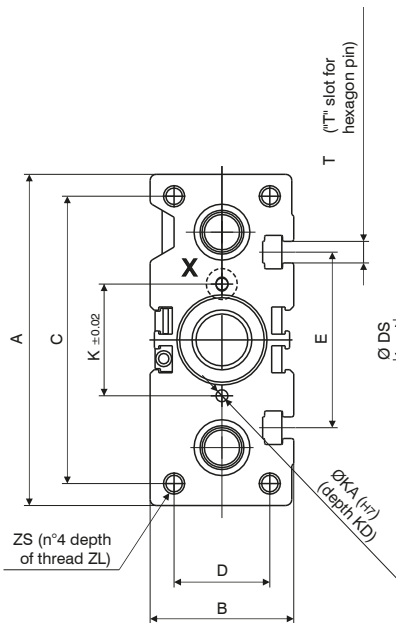
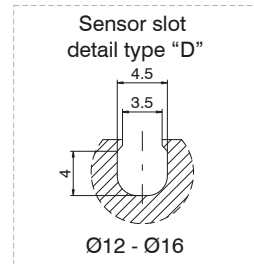
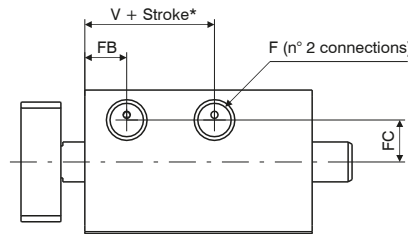
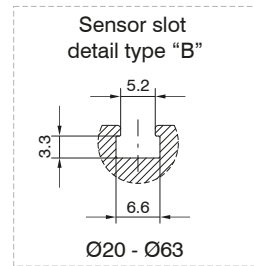
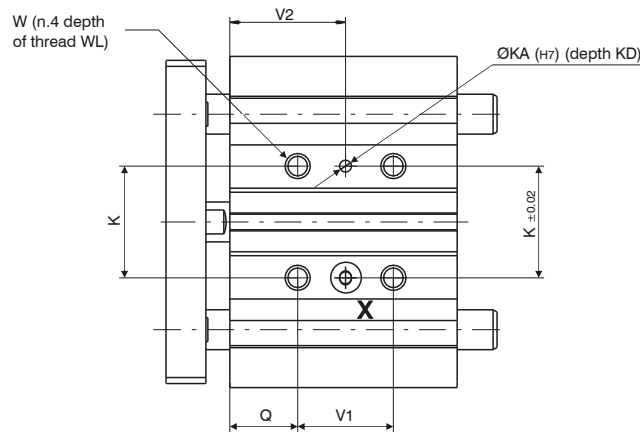
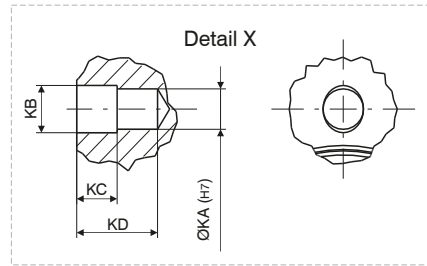
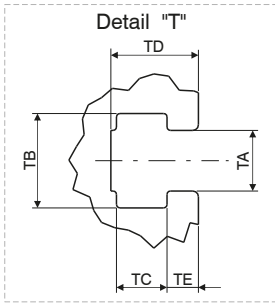

\*Dimensions only refer to the "standard stroke"



Overall dimensions

Bore		Ø12	Ø16	Ø20	Ø25	Ø32	Ø40	Ø50	Ø63
Table of dimensions									
A		58	64	83	93	112	120	148	162
B		26	30	36	42	48	54	64	78
C		40	42	72	82	98	106	130	142
D		18	22	24	30	34	40	46	58
Control unit with bronze bushes	DA	8	10	12	16	20	20	25	25
	Control unit with bearing bushes	6	8	10	14	16	16	20	20
DP		2	2	5,5	5,5	9,5	10	13	13
DS		6	8	10	12	16	16	20	20
E		/	/	44	50	63	72	92	110
F		M5	M5	G1/8"	G1/8"	G1/8"	G1/8"	G1/4"	G1/4"
FA		11	11	11	12	13	13	13	14
FB		11	11	11	12	13	13	13	14
FC		8,5	10	10,5	13,5	15	18	21,5	28
FP		15	17	9	10,5	9,5	11	11	12,5
G		14	16	18	26	30	30	40	50
H		41,5	46	54	64	78	86	110	124
HA		19,5	23	25	28,5	34	38	47	55
K		23	24	28	34	42	50	66	80
KA		/	/	3	4	4	4	5	5
KB		/	/	3,5	4,5	4,5	4,5	6	6
KC		/	/	3	3	3	3	4	4
KD		/	/	6	6	6	6	8	8
L		29	31	38	38,5	38,5	44	44	49
Control unit with bronze bushes	L1	39	43	53,5	54	60	66	72	77
	Control unit with bearing bushes	39	43	53,5	54	97	97	106,5	106,5
Control unit with bearing bushes	LT	57	64	84,5	85	102	102	118	118
	See table 1								
M		56	62	81	91	110	118	146	158
N		48	52	70	78	96	104	130	130
PA		8	10	10	10	12	12	15	15
P		22	25	30	38	44	44	60	70
Q		5	5	17,5	17,5	21,5	22	24	24
Control unit with bronze bushes	SA	/	/	/	/	37	31	34,5	29,5
		Control unit with bearing bushes	18	21	31	31	42	36	46
See table 1									
T		/	/	M5	M5	M6	M6	M8	M10
TA		/	/	5,4	5,4	6,5	6,5	8,5	11
TB		/	/	8,4	8,4	10,5	10,5	13,5	17,8
TC		/	/	4,5	4,5	5,5	5,5	7,5	10
TD		/	/	7,8	8,2	9,5	11	13,5	18,5
TE		/	/	2,8	3	3,5	4	4,5	7
UA		4,3	4,3	5,6	5,6	6,6	6,6	8,6	8,6
UB		8	8	9,5	9,5	11	11	14	14
UL		4,5	4,5	5,5	5,5	7,5	7,5	9	9
V		14	14	13	13	7,5	13	9	14
V1		See table 2							
V2		See table 2							
W		M5	M5	M6x1	M6x1	M8x1,25	M8x1,25	M10x1,5	M10x1,5
WL		10	10	12	12	16	16	20	20
Z		M4	M5	M5x0,8	M6x1	M8x1,25	M8x1,25	M10x1,5	M10x1,5
ZL		9	11	13	15	20	20	22	22

Control unit with bearing bushes	Table 1	LT			SA		
	Bore	stroke ≤ 30	30 < stroke ≤ 100	100 < stroke ≤ 200	stroke ≤ 30	30 < stroke ≤ 100	100 < stroke ≤ 200
Ø12		39	53	53	/	14	/
Ø16		43	64	64	/	21	/
Ø20		47	72	72	/	18,5	49
Ø25		49	77	77	/	23	48
		stroke < 50	50 ≤ stroke ≤ 100	100 < stroke ≤ 200	stroke < 50	50 ≤ stroke ≤ 100	100 < stroke ≤ 200
Ø32		/	87	117	/	27	57
Ø40		/			/	21	51
Ø50		/	92	127	/	20	55
Ø63		/			/	15	50

Control unit with bearing bushes	Table 2	V1			V2		
	Bore	stroke ≤ 30	30 < stroke ≤ 100	100 < stroke ≤ 200	stroke ≤ 30	30 < stroke ≤ 100	100 < stroke ≤ 200
Ø12		4 + stroke			/	/	/
Ø16					/	/	/
Ø20		24	44	120	29,5	39,5	77,5
Ø25		stroke ≤ 25			stroke ≤ 25	25 < stroke ≤ 100	100 < stroke ≤ 200
Ø32					33,5	45,5	83,5
Ø40		24	48	124	34	46	84
Ø50					36	48	86
Ø63		28	52	128	38	50	88



**Weight - Cylinder force - kinetic energy**

Stroke	Bore																
	Ø12		Ø16		Ø20		Ø25		Ø32		Ø40		Ø50		Ø63		
	<b>Control unit with bronze bushes</b>																<b>Weight g</b>
10	240		330		/		/		/		/		/		/		/
20	280		380		670		950		/		/		/		/		/
25	/		/		/		/		1690		1950		3360		4180		/
30	310		430		750		1050		/		/		/		/		/
40	350		480		830		1160		/		/		/		/		/
50	390		530		910		1270		2070		2370		4000		4940		/
75	500		680		1170		1650		2470		2830		4730		5780		/
100	5903		800		1370		1920		2850		3250		5370		6540		/
125	/		/		1570		2190		3240		3680		6010		7290		/
150	/		/		1760		2470		3620		4100		6650		8050		/
175	/		/		1960		2740		4000		4530		7290		8800		/
200	/		/		2160		3010		4380		4950		7930		9560		/
Stroke	<b>Moving parts</b>																
10	100		155		/		/		/		/		/		/		/
20	108		170		330		520		/		/		/		/		/
25	/		/		/		/		1070		1140		2150		2500		/
30	116		185		350		560		/		/		/		/		/
40	124		200		380		600		/		/		/		/		/
50	132		215		400		640		1230		1300		2400		2750		/
75	152		250		520		840		1420		1490		2750		3090		/
100	172		285		580		950		1580		1650		3000		3350		/
125	/		/		640		1050		1740		1810		3260		3600		/
150	/		/		700		1150		1910		1980		3510		3860		/
175	/		/		760		1250		2070		2140		3760		4110		/
200	/		/		820		1350		2230		2300		4020		4360		/
Stroke	<b>Control unit with bearing bushes</b>																
10	240		340		/		/		/		/		/		/		/
20	270		390		700		980		/		/		/		/		/
25	/		/		/		/		1540		1790		3110		3930		/
30	300		430		770		1070		/		/		/		/		/
40	350		510		890		1250		/		/		/		/		/
50	390		560		970		1340		1850		2150		3660		4590		/
75	470		670		1140		1570		2300		2640		4410		5460		/
100	560		790		1310		1810		2620		3000		4960		6120		/
125	/		/		1520		2080		2990		3420		5600		6880		/
150	/		/		1690		2310		3310		3780		6150		7540		/
175	/		/		1870		2540		3620		4140		6700		8210		/
200	/		/		2040		2770		3940		4500		7250		8870		/
Stroke	<b>Moving parts</b>																
10	95		145		/		/		/		/		/		/		/
20	100		153		310		490		/		/		/		/		/
25	/		/		/		/		820		890		1770		2110		/
30	105		161		330		520		/		/		/		/		/
40	110		169		370		580		/		/		/		/		/
50	120		177		390		610		940		1010		1950		2300		/
75	145		197		440		690		1110		1180		2240		2590		/
100	170		217		480		760		1230		1300		2430		2770		/
125	/		/		560		880		1410		1480		2710		3050		/
150	/		/		600		950		1530		1600		2890		3240		/
175	/		/		650		1020		1650		1720		3080		3420		/
200	/		/		700		1100		1770		1830		3270		3610		/
Working pressure	<b>Cylinder theoretic force (N)</b>																
2 bar	23	17	40	30	63	47	98	76	161	121	251	211	393	330	623	561	
3 bar	34	26	60	45	94	71	147	113	241	181	377	317	589	495	935	841	
4 bar	45	34	80	60	126	94	196	151	322	241	503	422	785	660	1247	1121	
5 bar	57	43	101	76	157	118	246	189	402	302	629	528	982	825	1559	1402	
6 bar	68	51	121	91	188	142	295	227	482	362	754	634	1178	989	1870	1682	
7 bar	79	60	141	106	220	165	344	265	563	422	880	739	1374	1154	2182	1962	
8 bar	90	68	161	121	251	189	393	302	643	482	1006	845	1570	1319	2494	2242	
9 bar	102	77	181	136	283	212	442	340	724	543	1131	950	1767	1484	2805	2523	
10 bar	113	85	201	151	314	236	491	378	804	603	1257	1056	1963	1649	3117	2803	
Piston area (mm <sup>2</sup> )	out	in	out	in	out	in	out	in	out	in	out	in	out	in	out	in	
	113	85	201	151	314	236	491	378	804	603	1257	1056	1963	1649	3117	2803	
	<b>Maximum permissible Momentum</b>																
J	0,08		0,09		0,11		0,18		0,29		0,52		0,91		1,54		

How to calculate the Momentum:  $E_c = \frac{1}{2} m V^2$  (J)

**m** = Total moving mass: weight of driven object added to weight of cylinder moving parts (kg)

**V** = max. speed: equal to average speed + 40% (m/sec)

PNEUMATIC ACTUATION 3



**Operating criteria**

**Permissible lateral load** (applied on overall plate)

Version	Stroke	Bore							
		Ø12	Ø16	Ø20	Ø25	Ø32	Ø40	Ø50	Ø63
		<b>Permissible lateral load (N)*</b>							
Control unit with bronze bushes	10	30	48						
	20	23	37	49	69				
	25					203	203	296	296
	30	19	30	43	60				
	40	16	25	38	54				
	50	14	20	35	49	164	164	245	245
	75	12	18	87	116	182	182	273	273
	100	10	15	75	100	159	159	241	241
	125			66	88	142	142	216	216
	150			59	79	127	127	195	195
	175			54	71	116	116	179	179
	200			49	65	106	106	164	164
	Control unit with bearing bushes	10	20	35					
20		15	28	58	69				
25						191	190	208	206
30		13	22	48	68				
40		11	18	101	132				
50		10	16	90	118	157	157	173	171
75		8	14	70	93	164	163	223	221
100		6	11	58	77	144	144	199	196
125				62	80	203	203	264	262
150				54	70	186	185	242	240
175				48	62	171	171	224	221
200				43	55	158	158	207	205
		<b>Recommended torque moments (Nm)</b>							
Control unit with bronze bushes	10	0,40	0,70						
	20	0,35	0,65	1,1	1,8				
	25					6,4	7,0	13,0	14,7
	30	0,28	0,48	0,9	1,6				
	40	0,25	0,45	0,8	1,4				
	50	0,21	0,39	0,8	1,3	5,1	5,7	10,8	12,1
	75	0,42	0,68	1,9	3,0	5,7	6,3	12,0	13,5
	100	0,40	0,60	1,6	2,6	5,0	5,5	10,6	11,9
	125			1,4	2,3	4,4	4,9	9,5	10,7
	150			1,3	2,0	4,0	4,4	8,6	9,7
	175			1,2	1,8	3,6	4,0	7,9	8,9
	200			1,1	1,7	3,3	3,7	7,2	8,2
	Control unit with bearing bushes	10	0,62	0,70					
20		0,41	0,65	1,3	2,1				
25						6,0	6,6	9,2	10,2
30		0,33	0,48	1,0	1,8				
40		0,30	0,45	2,2	3,4				
50		0,48	0,39	1,9	3,0	4,9	5,4	7,6	8,5
75		0,38	0,68	1,5	2,4	5,1	5,6	9,8	11,0
100		0,32	0,60	1,3	2,0	4,5	5,0	8,7	9,7
125				1,3	2,1	6,3	7,0	11,6	13,0
150				1,2	1,8	5,8	6,4	10,7	11,9
175				1,0	1,6	5,3	5,9	9,8	11,0
200				0,9	1,4	4,9	5,4	9,1	10,2

\*(Applied on overall plate)

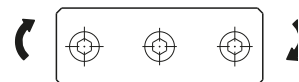
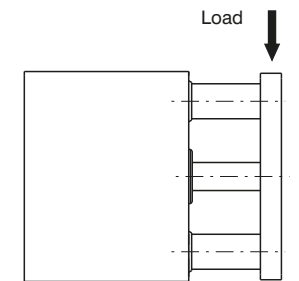
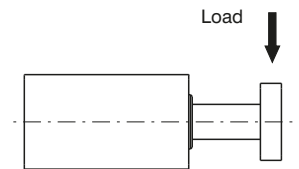

**3**  
PNEUMATIC ACTUATION

Operating criteria

Stopper device applications

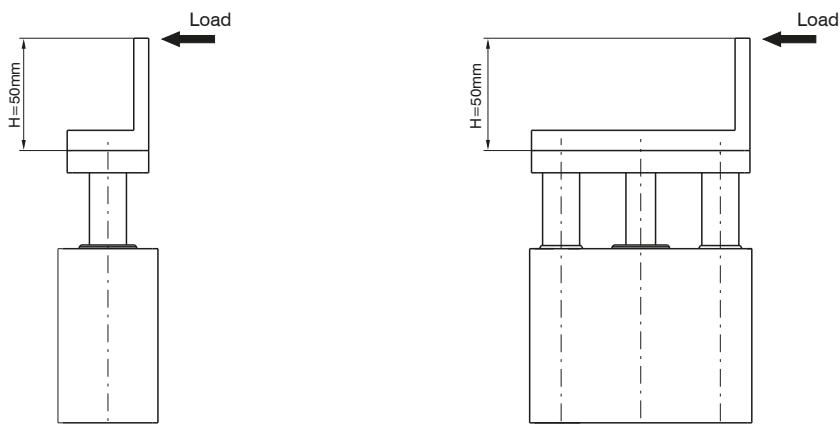

Control unit with  
bronze bushes

ATTENTION: if  $H > 50$  mm use larger bore

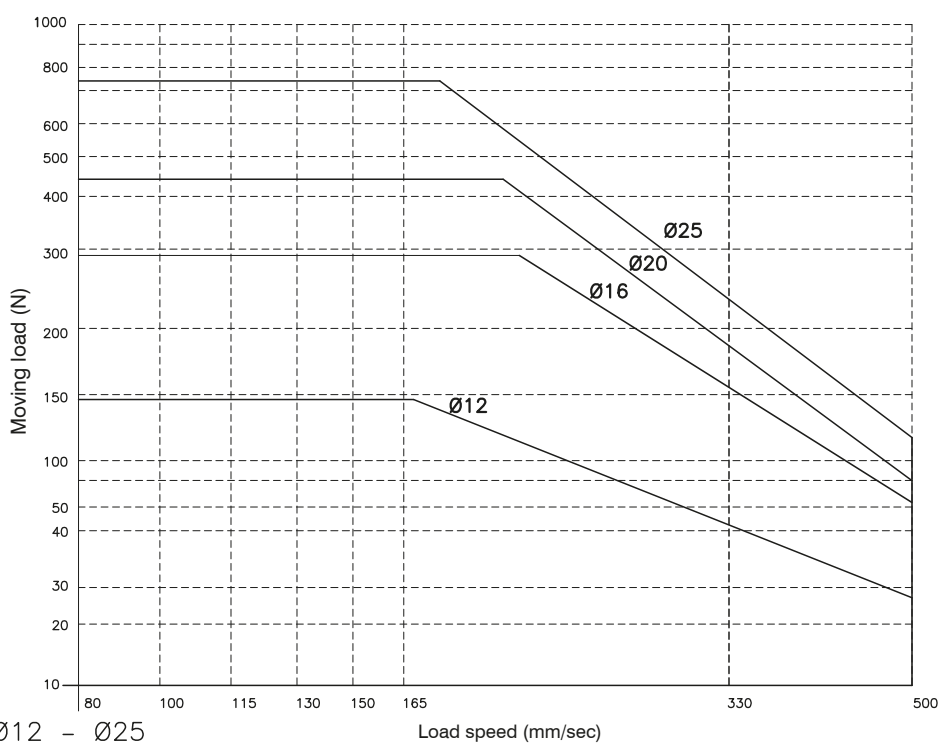

Ø12 - Ø25  
ATTENTION: use with stroke  $\leq 30$  mm

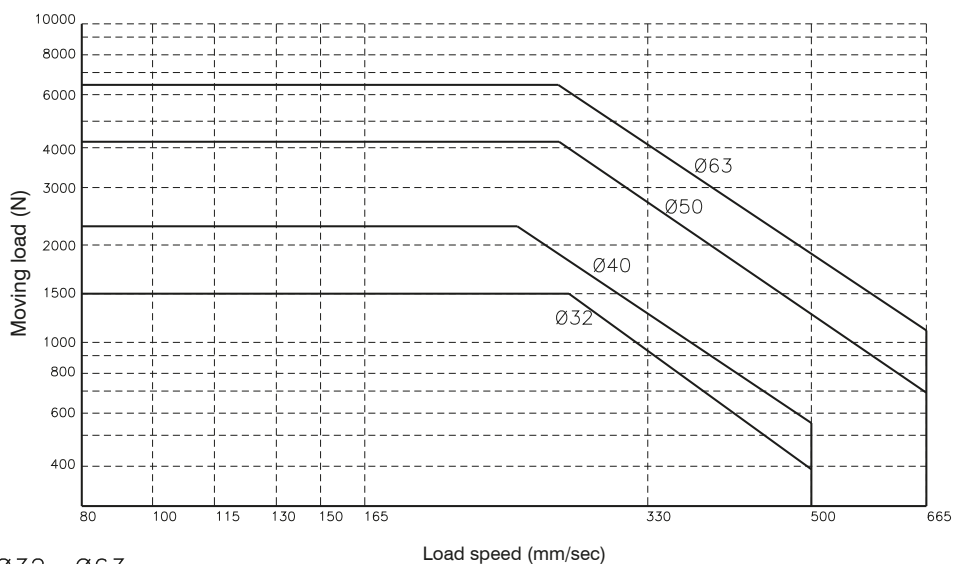

Ø32 - Ø63  
ATTENTION: use with stroke  $\leq 50$  mm

Operating criteria  
Handling applications

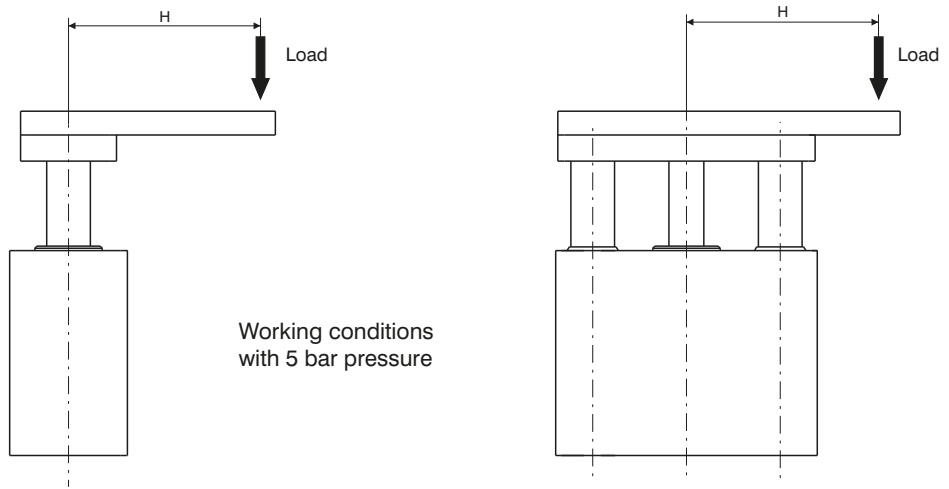

Control unit with bronze bushes

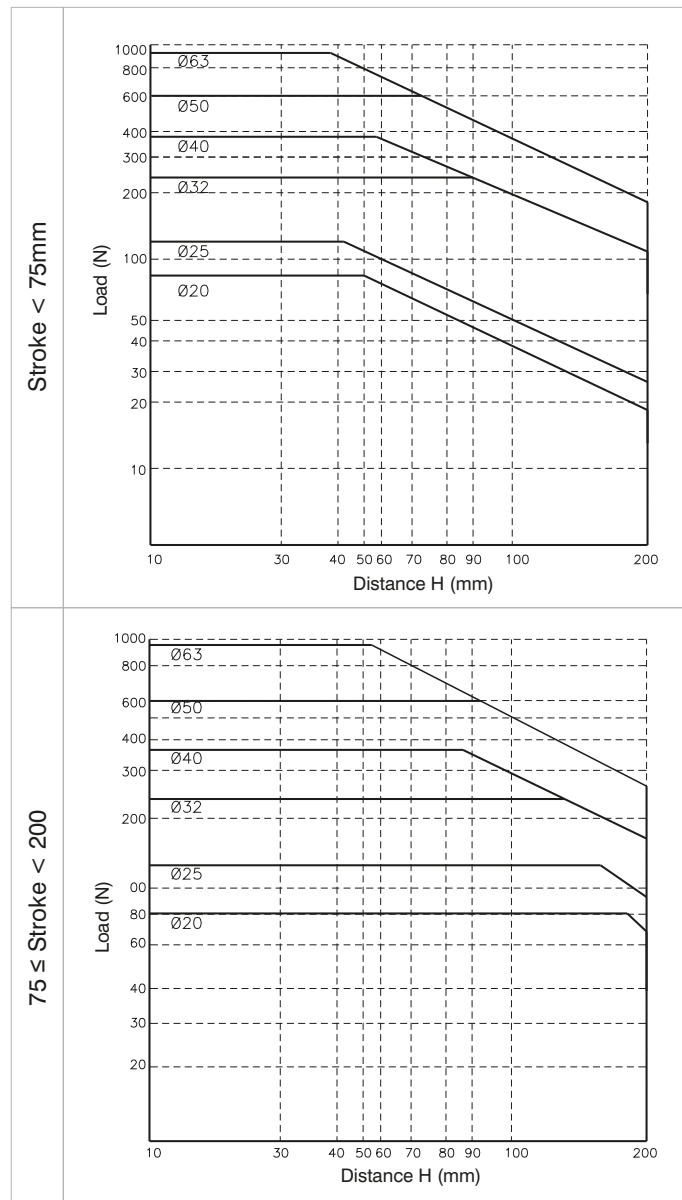

Operating criteria

Handling applications

Control unit with bearing bushes

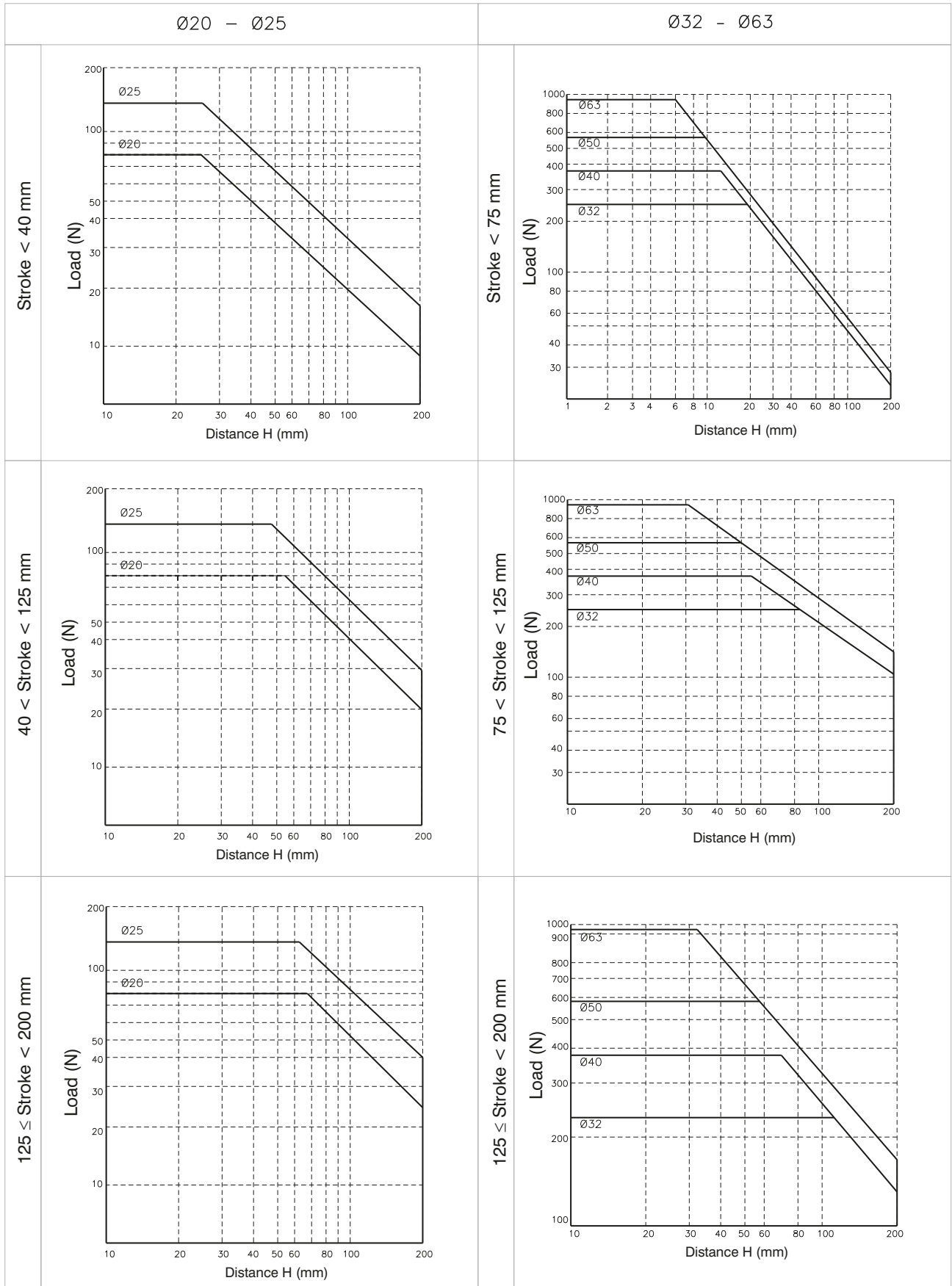

► Heavy duty guided short stroke cylinder

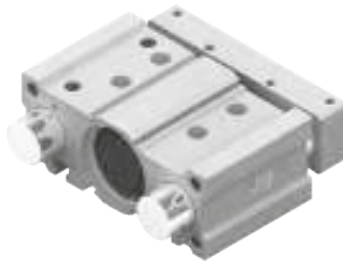

Ordering code

**6101.80.stroke. B .**

— Side supply ports closed  
L = Top supply ports closed

Construction characteristics

Body	anodised aluminium
Rods	C43 chromed steel
Piston	aluminium
Piston rod	C43 chromed steel
Piston rod bushing	sintered bronze
Rod bushing	teflon coated bush
End cap	aluminium
Piston seal	NBR oil-resistant rubber
Piston rod seal	PUR
Plate	anodised aluminium

Operational characteristics

Function	double acting
Fluid	Filtered air. No lubrication needed, if applied it shall be continuous.
Max. pressure	max. 10 bar
Working temperature	-5°C - +70°C
Cushioning	elastic bumper on both ends

Standard strokes

Bore	Stroke							
	25	50	75	100	125	150	175	200
Ø80	●	●	●	●	●	●	●	●

Intermediate strokes can be obtained by adding specific spacers (5, 10, 15, 20mm).

Example: It is possible to obtain a **6101.80.45.B** cylinder from a **6101.80.50.B** cylinder by adding a 5mm spacer.  
The Intermediate strokes manufactured without the use of spacers are considered special executions.

**Overall dimensions**

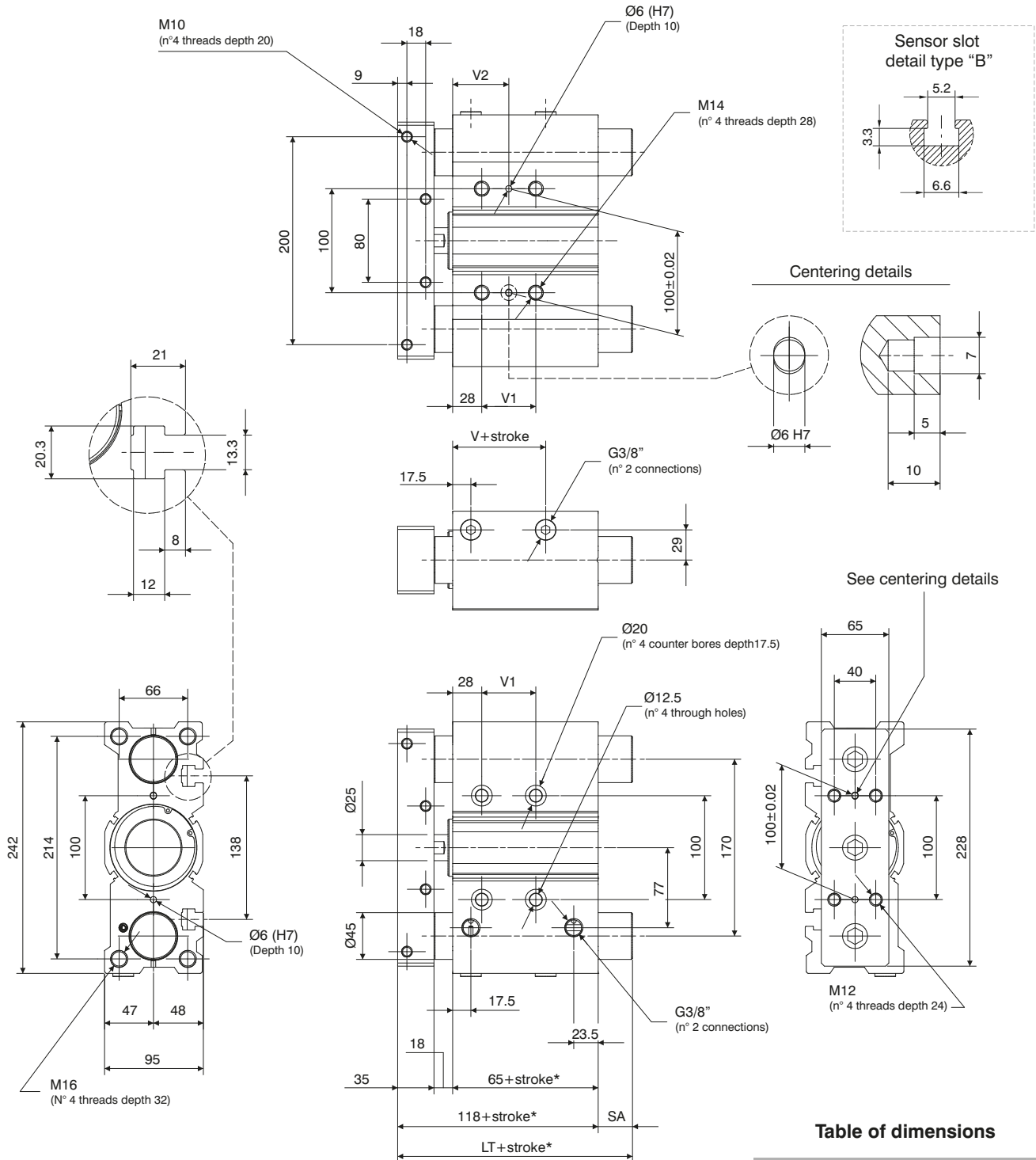

\*Dimensions only refer to the "standard stroke"

**Table of dimensions**

	25		118
stroke	50	<b>LT</b>	118
	> 50		151
		<b>V</b>	14.5
	25		28
	50	<b>V1</b>	52
stroke	75		52
	100		52
	>100		128
	25	<b>V2</b>	42
	50		54
stroke	75		54
	100		54
	>100	92	
	25	<b>SA</b>	0
stroke	50		
	> 50		33

Operating criteria

Cylinder theoretic force (N)

Working pressure		
2 bar	1005	907
3 bar	1508	1361
4 bar	2011	1814
5 bar	2513	2268
6 bar	3016	2721
7 bar	3519	3175
8 bar	4021	3629
9 bar	4524	4082
10 bar	5027	4536
Effective area (mm <sup>2</sup> )	out	in
	5027	4536

Recommended torque moments

Stroke	N/m
25	49
50	41
75	51
100	45
125	41
150	38
175	35
200	32

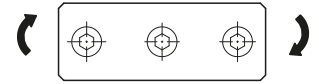

“Stopper” device applications

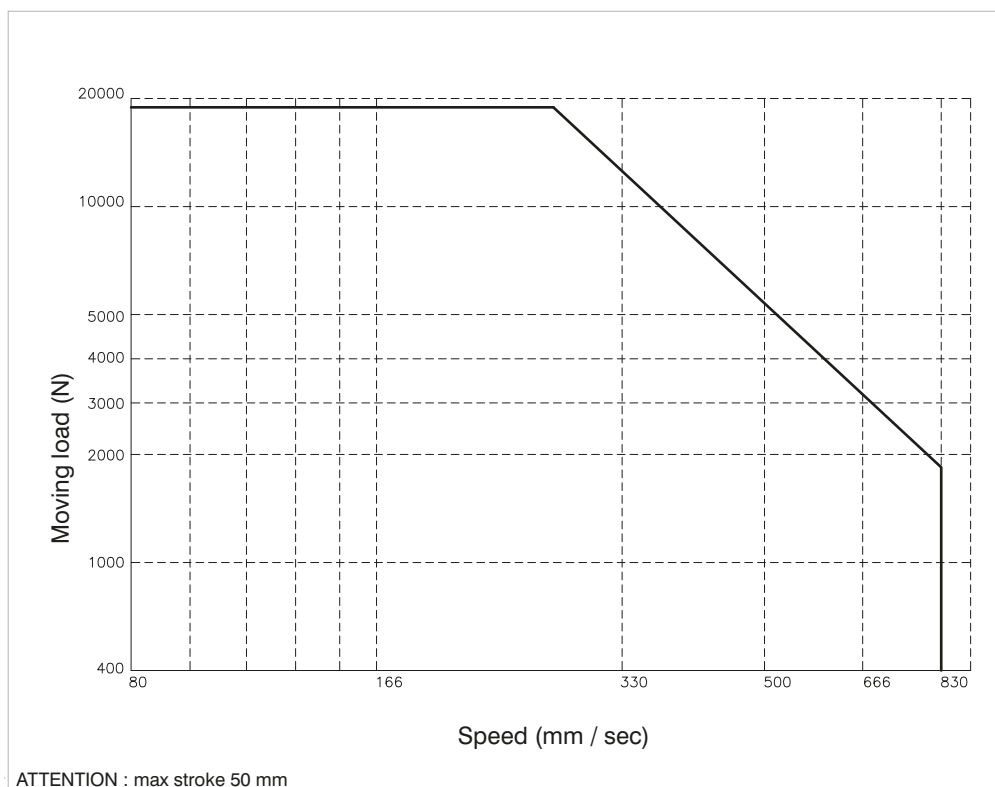
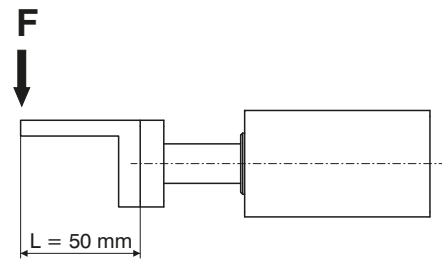
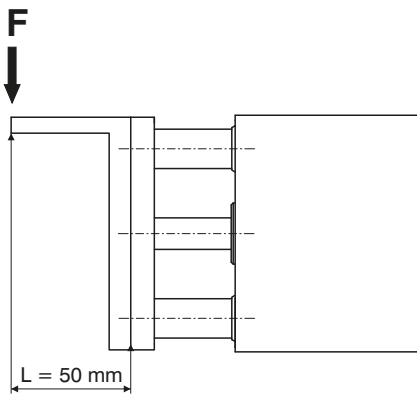

Operating criteria

Handling applications

VERTICAL assembly position

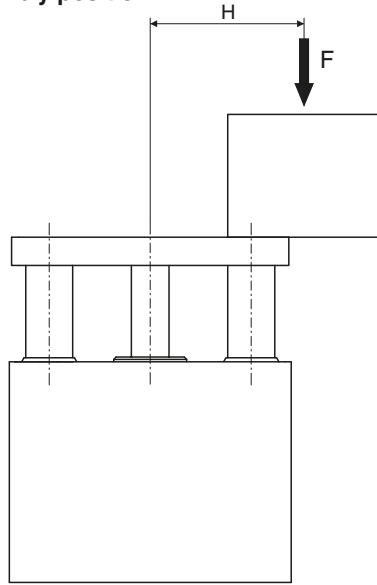

HORIZONTAL assembly position

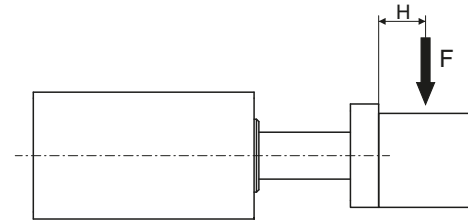

PNEUMATIC ACTUATION

STROKE  $\leq 50$  mm / V = 200 mm/s

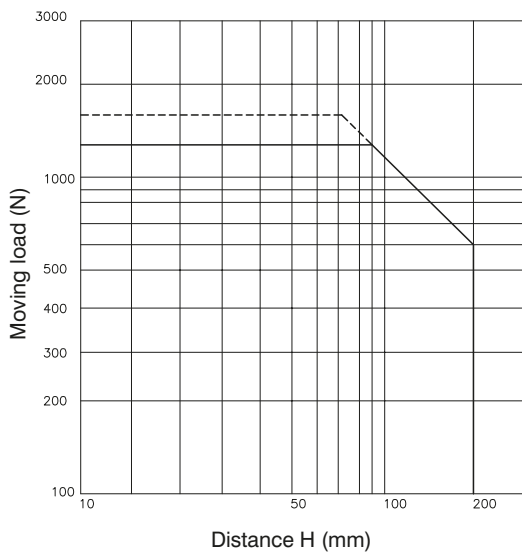

H = 50 mm / V = 200 mm/s

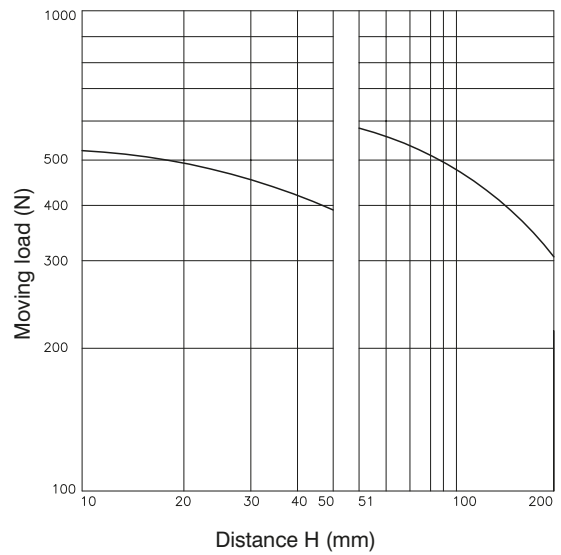

STROKE  $> 50$  mm / V = 200 mm/s

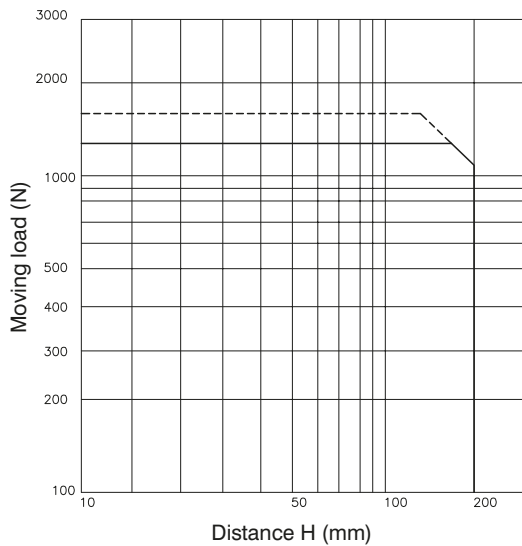

H = 100 mm / V = 200 mm/s

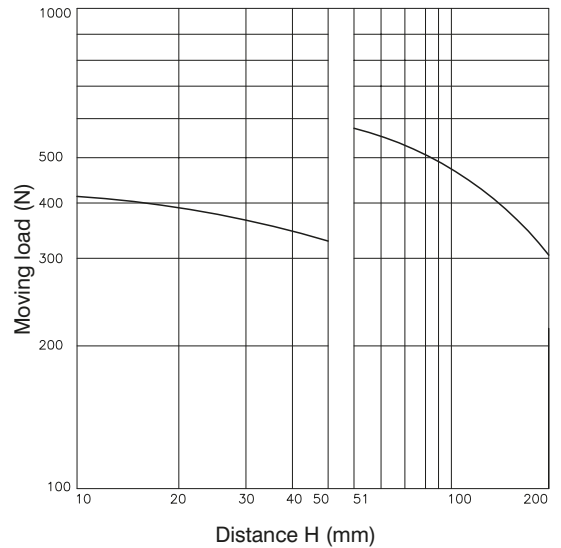

———— Working pressure : 4 bar  
- - - - - Working pressure : 5 bar



► Guided compact cylinder with additional metal rod scrapers



Ordering code

6110.Ø.stroke. C .

- 32
- 40
- 50
- 63

Side supply ports closed  
L = Top supply ports closed

Construction characteristics

Body	anodised aluminium
Guide rods	tempered and chromed steel
Piston	aluminium
Piston rod	C43 chromed steel
Rods bushing	bearing bushing
End cap	anodised aluminium
Piston seal	oil resistant NBR rubber
Piston rod seal	PUR
External rod scraper	brass
Internal rod scraper	NBR
Plate	nickel plated steel

The cylinders are equipped with 4 rod scrapers on the guide rods and 1 rod scraper on the central piston rod

Operational characteristics

Function	double acting
Fluid	Filtered air. No lubrication needed, if applied it shall be continuous.
Working pressure	max. 10 bar
Working temperature	-5°C - +70°C
Cushioning	elastic bumper on both ends

Standard strokes

Bore	Stroke									
	10	20	25	50	75	100	125	150	175	200
Ø32			●	●	●	●	●	●	●	●
Ø40			●	●	●	●	●	●	●	●
Ø50			●	●	●	●	●	●	●	●
Ø63			●	●	●	●	●	●	●	●

Intermediate strokes can be obtained using spacers with defined length (5, 10, 15, 20 mm).

Example: It is possible to obtain a **6110.32.45.B** cylinder from a **6110.32.50.B** cylinder by inserting a spacer with length of 5 mm. The intermediate strokes manufactured without the use of spacers are considered special executions.

Overall dimensions

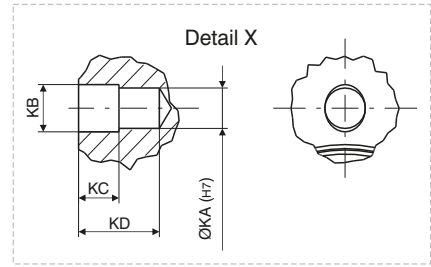
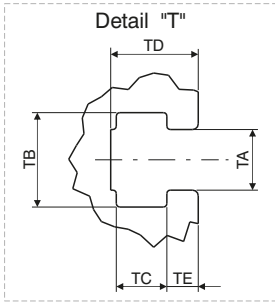

3

PNEUMATIC ACTUATION

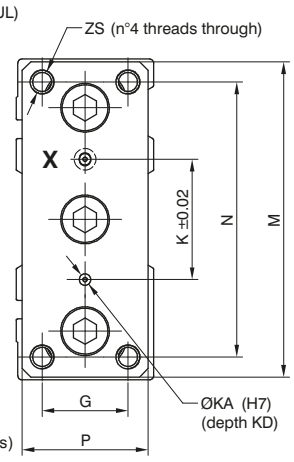
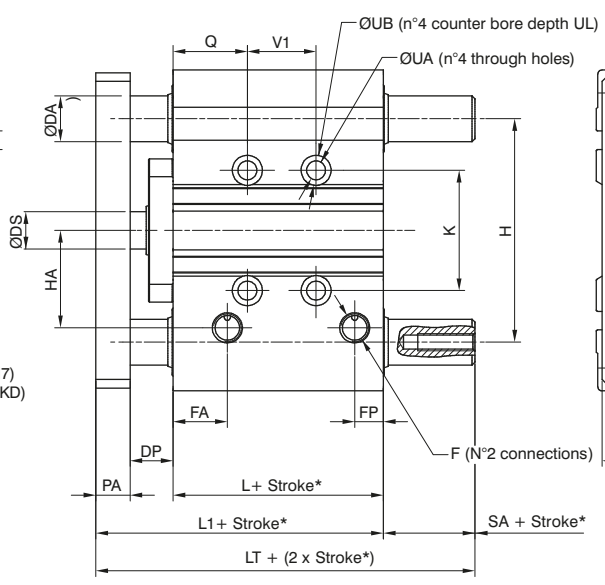
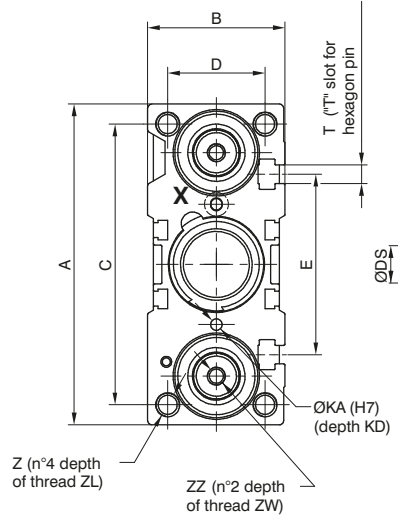
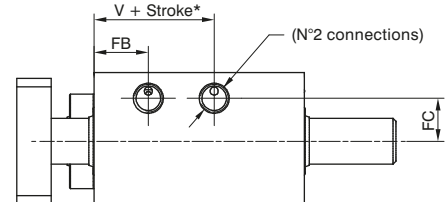
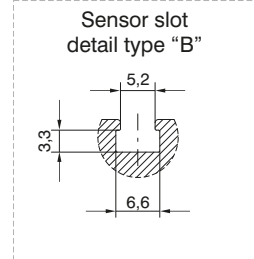
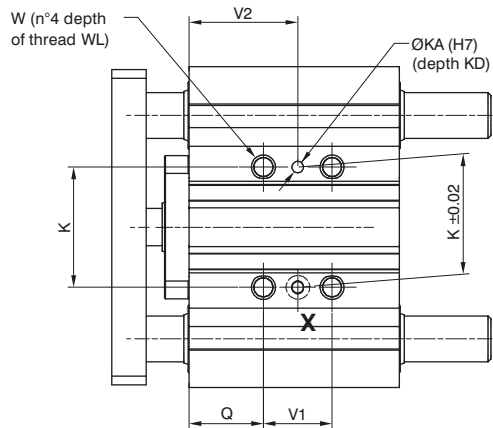



Overall dimensions

Bore	Ø32	Ø40	Ø50	Ø63
Table of dimensions				
A	112	120	148	162
B	48	54	64	78
C	98	106	130	142
D	34	40	46	58
DA	16	16	20	20
DP	15	20	23	23
DS	16	16	20	20
E	63	72	92	110
F	G1/8"	G1/8"	G1/4"	G1/4"
FA	19	13	13	14
FB	19	13	13	14
FC	15	18	21,5	28
FP	10	11	11	12,5
G	30	30	40	50
H	78	86	110	124
HA	34	38	47	55
K	42	50	66	80
KA	4	4	5	5
KB	4,5	4,5	6	6
KC	3	3	4	4
KD	6	6	8	8
L	48,5	50	50	55
L1	75,5	82	88	93
LT	82,5	89	93	100
M	110	118	146	158
N	96	104	130	130
PA	12	12	15	15
P	44	44	60	70
Q	26	22	24	24
SA	7	7	5	7
T	M6	M6	M8	M10
TA	6,5	6,5	8,5	11
TB	10,5	10,5	13,5	17,8
TC	5,5	5,5	7,5	10
TD	9,5	11	13,5	18,5
TE	3,5	4	4,5	7
UA	6,6	6,6	8,6	8,6
UB	11	11	14	14
UL	7,5	7,5	9	9
V	17	19	15	20
V1	See table 1			
V2				
W	M8x1,25	M8x1,25	M10x1,5	M10x1,5
WL	16	16	20	20
Z	M8x1,25	M8x1,25	M10x1,5	M10x1,5
ZL	20	20	22	22
ZS	M8x1,25	M8x1,25	M10x1,5	M10x1,5
ZZ	M6	M8	M10	M10
ZW	20	20	25	25

Table 1 Bore	V1			V2		
	stroke ≤ 25	25 < stroke ≤ 100	100 < stroke ≤ 200	stroke ≤ 25	25 < stroke ≤ 100	100 < stroke ≤ 200
Ø32	24	48	124	38	50	88
Ø40				34	46	84
Ø50				36	48	86
Ø63	28	52	128	38	50	88

3 PNEUMATIC ACTUATION

Slide cylinders



Ordering code

6600.Ø.stroke. \_ \_ \_

- 8 = Without accessories
- 12 **A** = Double regulation end stroke
- 16 **AU** = Regulation front end stroke
- 20 **AR** = Regulation rear end stroke
- 25 **D** = Double shock absorber
- DU** = Front shock absorber
- DR** = Rear shock absorber

Construction characteristics

Body	anodised aluminium
Piston rod	stainless steel
Piston	stainless steel
Piston rod bushing	sintered bronze
End cap	anodised aluminium
Cushioning washer	PUR
Seal	oil resistant NBR rubber
Flange	anodised aluminium
Upper plate	anodised aluminium

Operational characteristics

Fluid	Filtered air. No lubrication needed, if applied it shall be continuous.
Working pressure	1.5 - 7 bar
Working temperature	-5°C - +70°C
Cushioning	with elastic bumper

Theoretical force

Bore	Effective area (mm <sup>2</sup> )	Force (N)						
		2	3	4	5	6	7	
Ø8	Out	101	20	30	40	51	61	71
	In	75	15	23	30	38	45	53
Ø12	Out	226	45	68	90	113	136	158
	In	170	34	51	68	85	102	119
Ø16	Out	402	80	121	161	201	241	281
	In	302	60	91	121	151	181	211
Ø20	Out	628	126	188	251	314	377	440
	In	471	94	141	188	236	283	330
Ø25	Out	982	196	295	393	491	589	687
	In	756	151	227	302	378	454	529

Standard strokes

Bore	Stroke								
	10	20	30	40	50	75	100	125	150
Ø8	●	●	●	●	●	●			
Ø12	●	●	●	●	●	●	●		
Ø16	●	●	●	●	●	●	●	●	
Ø20	●	●	●	●	●	●	●	●	●
Ø25	●	●	●	●	●	●	●	●	●

Overall dimensions Ø8

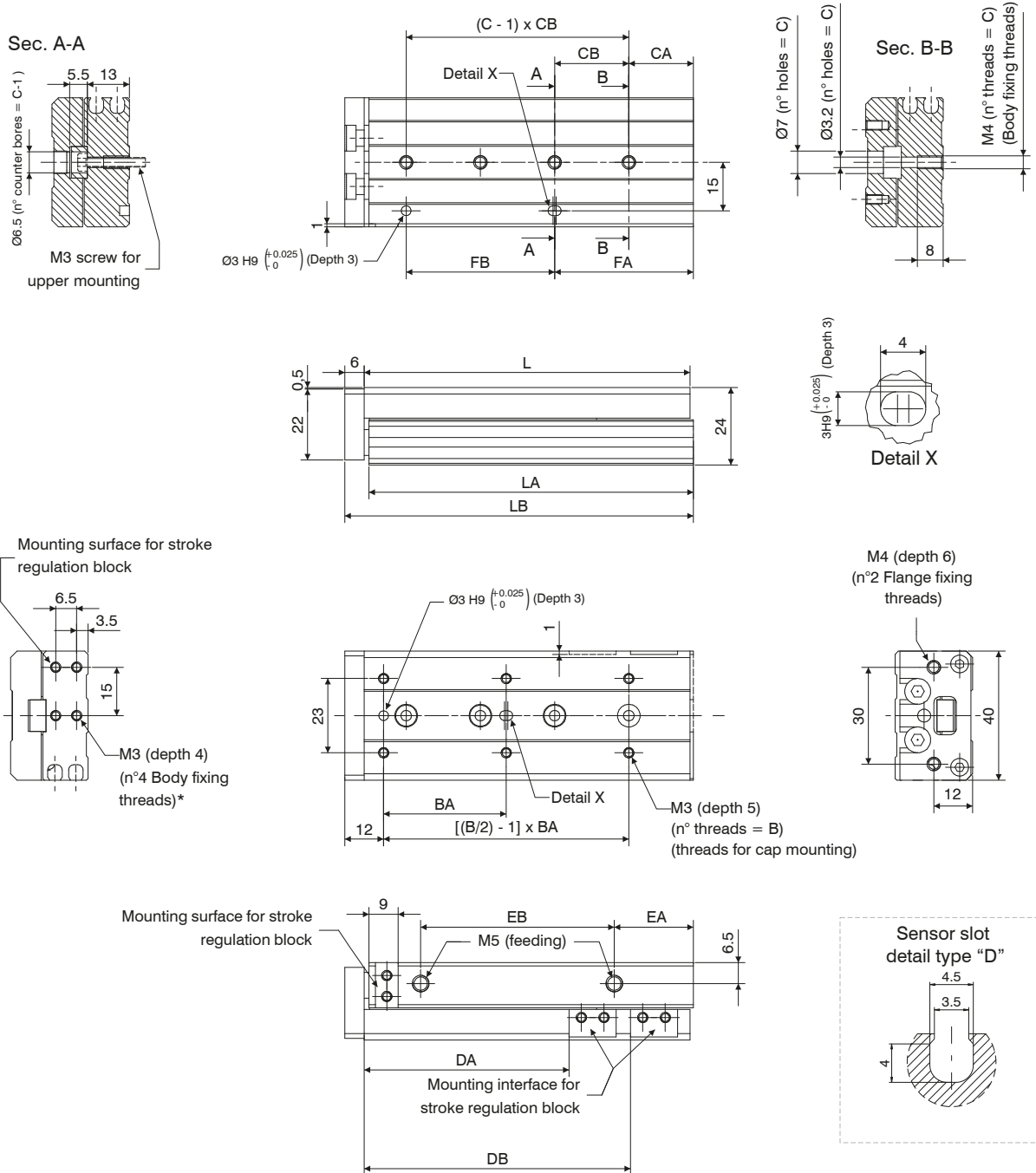
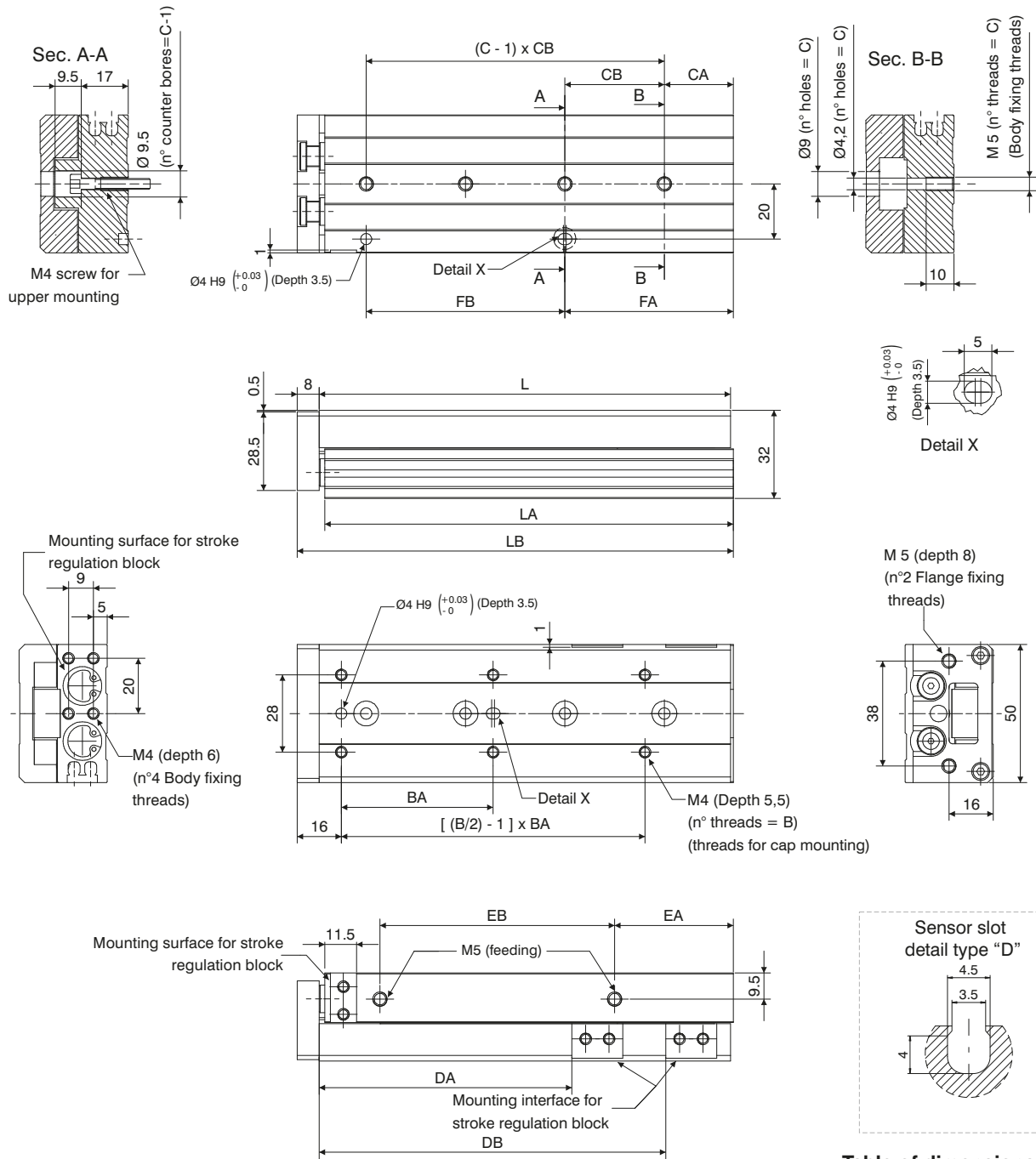

Table of dimensions

	Standard stroke					
	10	20	30	40	50	75
B	4	4	4	4	6	6
BA	25	25	40	50	38	50
C	2	2	3	3	4	5
CA	9	12	13	15	20	27
CB	28	30	20	28	23	28
DA	23,5	33,5	43,5	53,5	63,5	88,5
DB	/	/	/	/	82,5	132,5
FA	17	12	33	43	43	83
FB	20	30	20	28	46	56
EA	13	8,5	9,5	10,5	24,5	38,5
EB	19,5	29	39	56	60	96
L	49	54	65	83	101	151
LA	48,5	53,5	64,5	82,5	100,5	150,5
LB	56	61	72	90	108	158
<b>Weight g</b>	150	160	190	235	285	410

**Overall dimensions Ø12**



**Table of dimensions**

	Standard stroke						
	10	20	30	40	50	75	100
B	4				6		
BA		35		50	35	55	65
C		2		3	3	4	5
CA		15		17	15	25	35
CB		40		25	36	36	38
DA	26,5	36,5	46,5	56,5	66,5	91,5	116,5
DB	/	/	/	/	/	125,5	179,5
FA		15		42	51	61	111
FB		40		25	36	72	76
EA		10			22	43	52
EB		40		52	60	85	130
L		71		83	103	149	203
LA		70		82	102	148	202
LB		80		92	112	158	212
<b>Weight (gr.)</b>		325		385	480	660	890

Overall dimensions Ø16

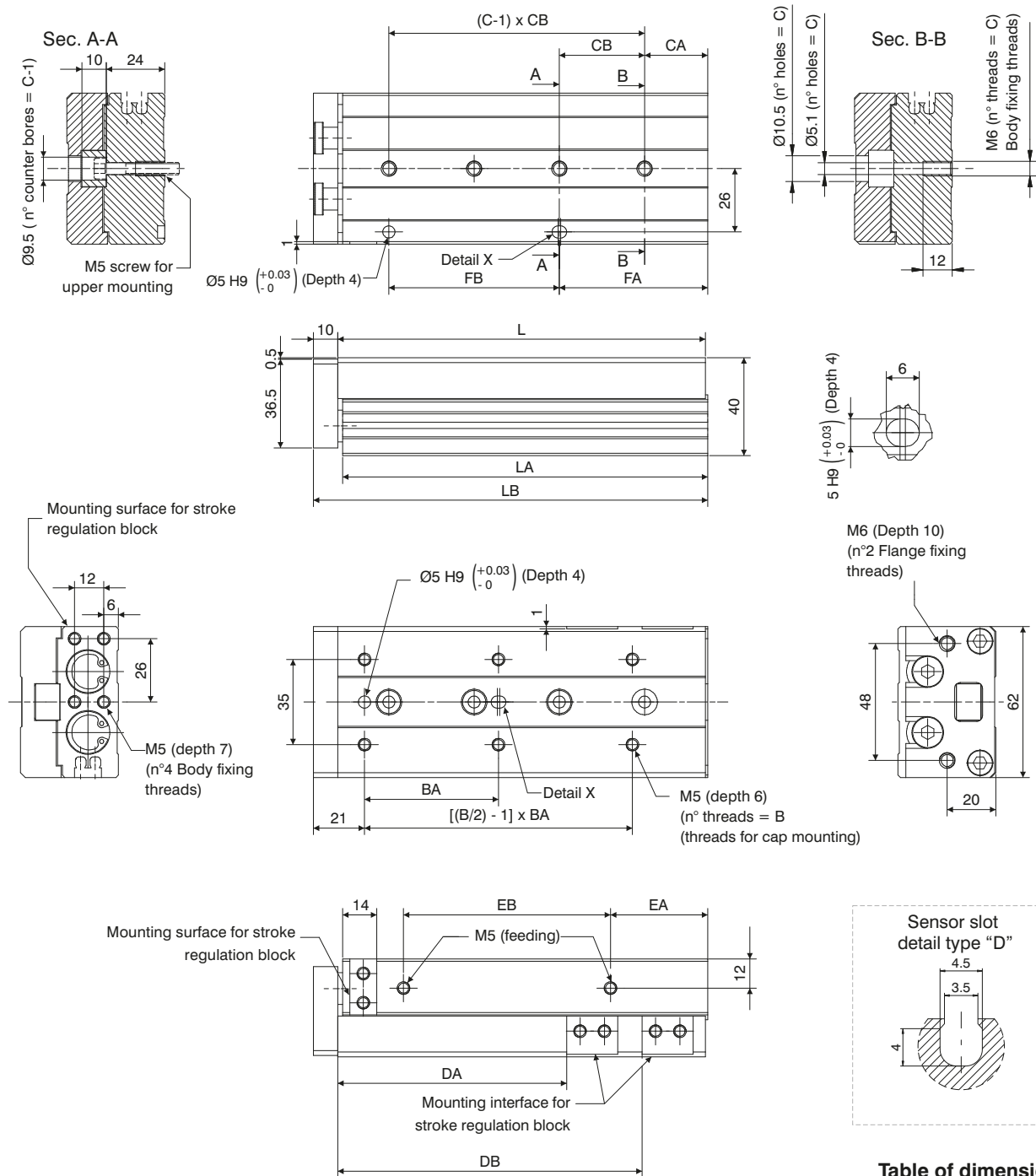
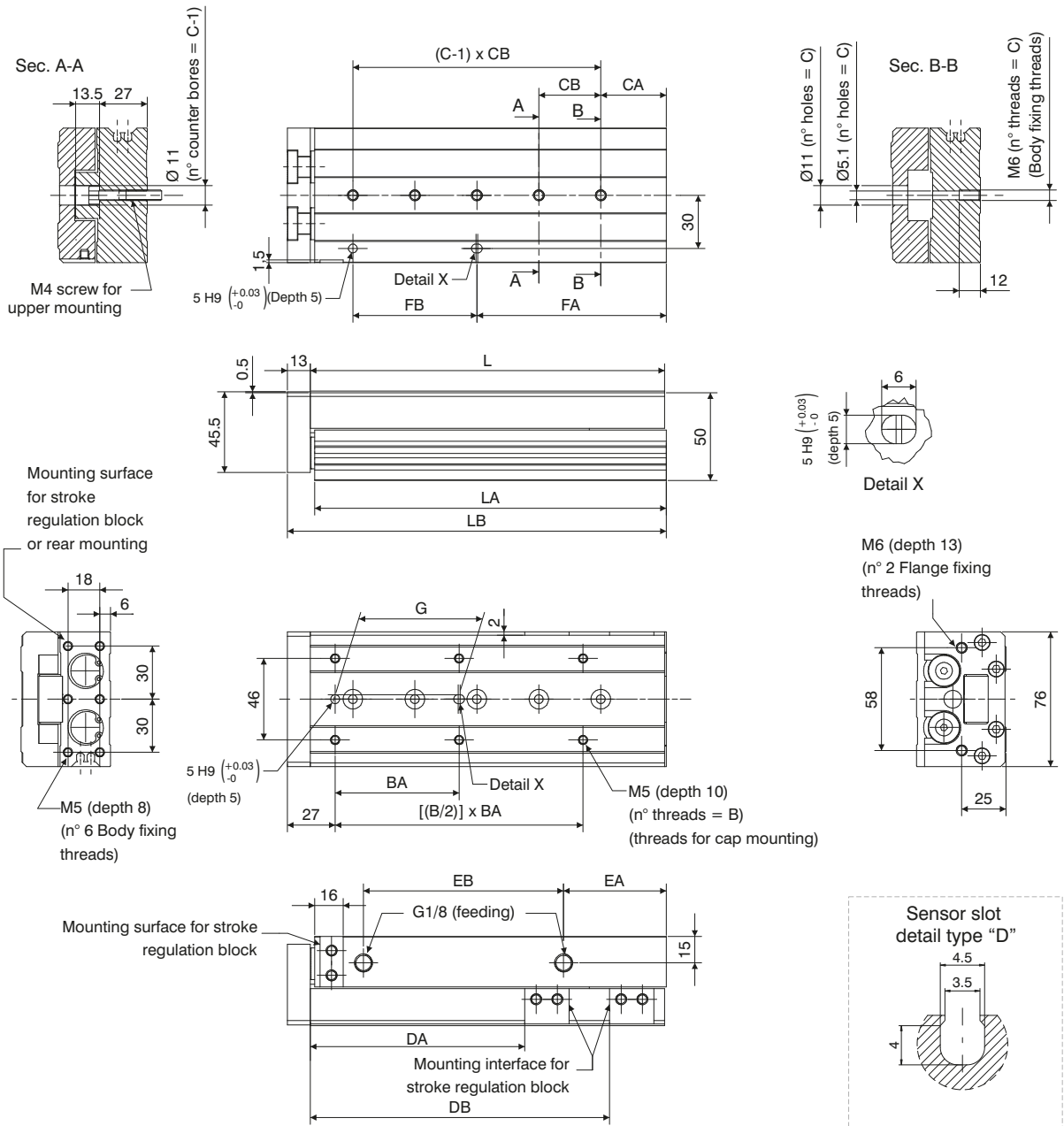

Table of dimensions

	Standard stroke							
	10	20	30	40	50	75	100	125
B	4	4	4	4	6	6	6	8
BA	35	35	35	40	30	55	65	70
C	2	2	2	2	3	4	5	7
CA	16	16	16	16	21	26	39	19
CB	40	40	40	50	30	35	35	35
DA	29	39	49	59	69	94	119	144
DB	/	/	/	/	/	125	173	223
FA	16	16	16	16	51	61	109	159
FB	40	40	40	50	30	70	70	70
EA	10	10	10	10	15	40	55	68
EB	40	40	40	50	60	85	118	155
L	76	76	76	86	101	151	199	249
LA	75	75	75	85	100	150	198	248
LB	87	87	87	97	112	162	210	260
Weight (gr.)	570	570	580	640	760	1090	1370	1700

**Overall dimensions Ø20**



**Table of dimensions**

	Standard stroke								
	10	20	30	40	50	75	100	125	150
B	4	4	4	4	6	6	6	8	8
BA	50	50	50	60	35	60	70	70	80
C	2	2	2	2	3	4	5	6	7
CA	15	15	15	15	15	19	37	41	19
CB	45	45	45	55	35	35	35	38	44
DA	31	41	51	61	71	96	121	146	171
DB	/	/	/	/	/	/	169	223	275
EA	10	10	10	10	10	10	58	70	87
EB	44	44	44	54	69	108	113	155	190
FA	25	25	25	35	50	54	107	155	195
FB	35	35	35	35	35	70	70	76	88
G	40	40	40	50	35	60	70	70	80
L	83	83	83	93	108	147	200	254	306
LA	81,5	81,5	81,5	91,5	106,5	145,5	198,5	252,5	304,5
LB	97	97	97	107	122	161	214	268	320
<b>Weight (gr.)</b>	960	980	1010	1100	1250	1630	2150	2670	3190



Overall dimensions Ø25

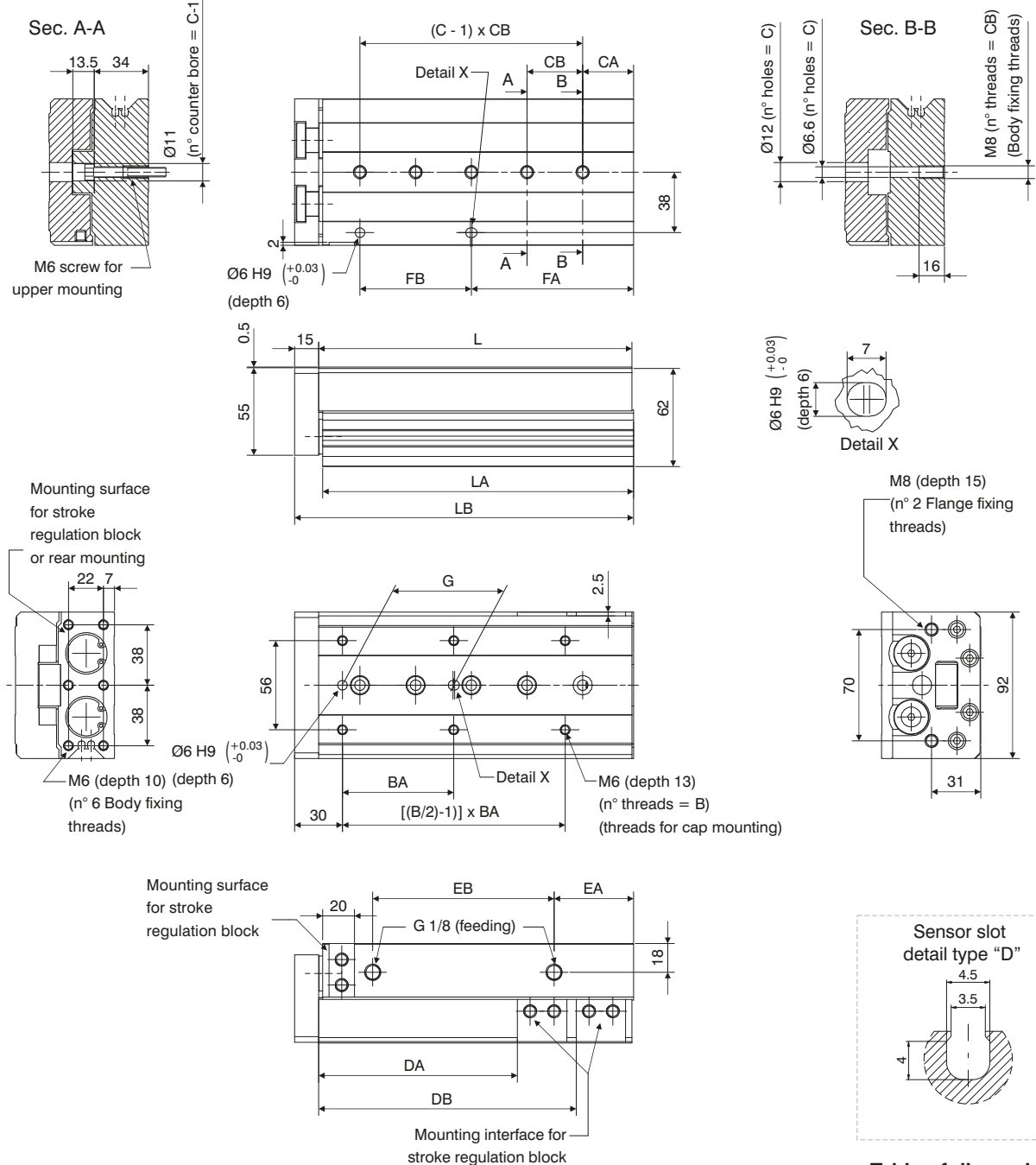
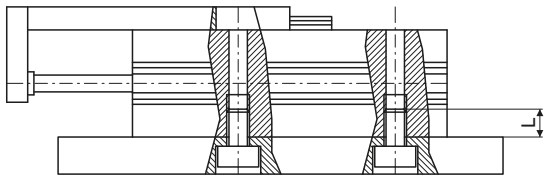

Table of dimensions

	Standard stroke									
	10	20	30	40	50	75	100	125	150	
B	4	4	4	4	6	6	6	8	8	
BA	50	50	50	60	35	60	70	75	80	
C	2	2	2	2	3	4	5	6	7	
CA	22	22	22	22	20	26	32	40	30	
CB	45	45	45	55	35	35	35	38	40	
DA	35	45	55	65	75	100	125	150	175	
DB	/	/	/	/	/	/	162	218	258	
EA	12	12	12	12	12	33	50	67	82	
EB	47	47	47	57	70	90	114	155	180	
FA	22	22	22	22	55	61	102	154	190	
FB	45	45	45	55	35	70	70	76	80	
G	40	40	40	50	35	60	70	75	80	
L	92	92	92	102	115	156	197	255	295	
LA	90,5	90,5	90,5	100,5	113,5	154,5	195,5	253,5	293,5	
LB	108	108	108	118	131	172	213	271	311	
Weight g	1660	1680	1690	1840	2090	2650	3270	4140	4710	

### Mounting options

#### SIDE THREADED HOLES



Bore	Screw	Torque (Nm)	Max. Length L (mm)
Ø8	M3	2,1	8
Ø12	M4	4,4	10
Ø16	M5	7,4	12
Ø20	M5	7,4	12
Ø25	M6	18	16

#### SIDE THROUGH HOLES

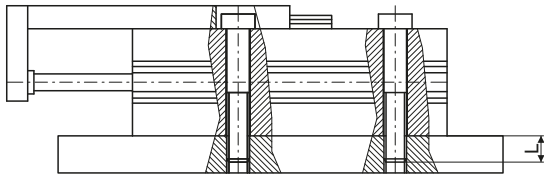

Bore	Screw	Torque (Nm)	Max. Length L (mm)
Ø8	M3	1,2	13
Ø12	M4	2,8	18,5
Ø16	M5	5,7	24
Ø20	M5	5,7	29
Ø25	M6	18	34

#### AXIAL THREADED HOLES

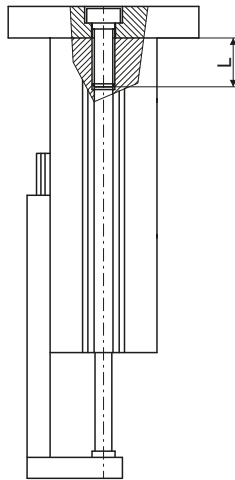

Bore	Screw	Torque (Nm)	Max. Length L (mm)
Ø8	M3	0,9	4
Ø12	M4	2,1	6
Ø16	M5	4,4	7
Ø20	M5	4,4	8
Ø25	M6	7,4	10

#### Mounting load

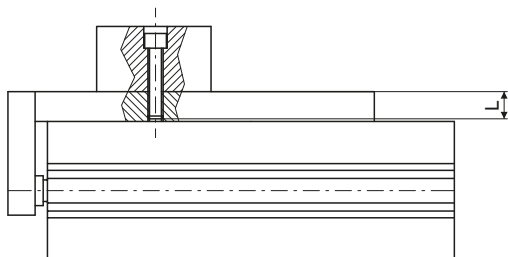

Bore	Screw	Torque (Nm)	Max. Length L (mm)
Ø8	M3	2,1	6
Ø12	M4	4,4	8
Ø16	M5	7,4	10
Ø20	M5	7,4	13
Ø25	M6	18	15

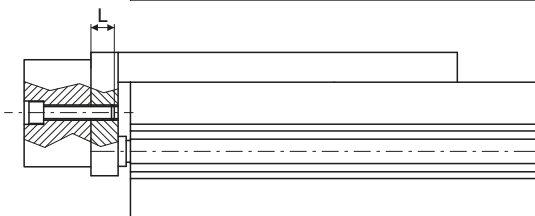

Bore	Screw	Torque (Nm)	Max. Length L (mm)
Ø8	M3	0,9	5
Ø12	M4	2,1	5,5
Ø16	M5	4,4	6
Ø20	M5	4,4	10
Ø25	M6	7,4	13

Kinetic energy (J)	Bore	With elastic bumper	With shock absorber
	Ø8	0,027	See Dampers 6900
	Ø12	0,055	
	Ø16	0,11	
	Ø20	0,16	
	Ø25	0,24	

### Plate deflection

With front moment under static conditions completely extended and with load applied as indicated by the arrows.

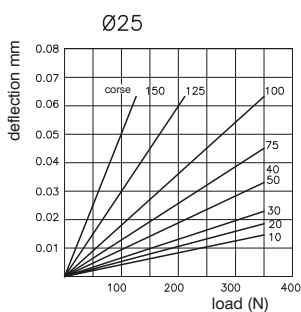
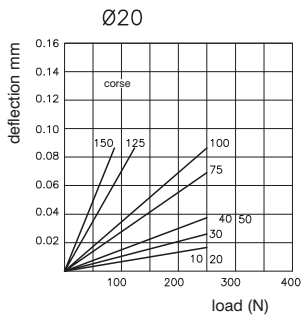
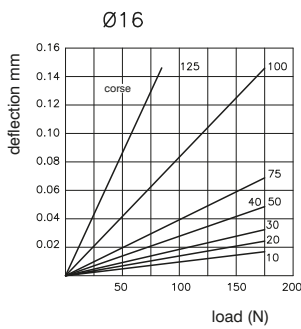
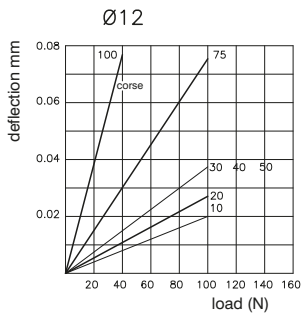
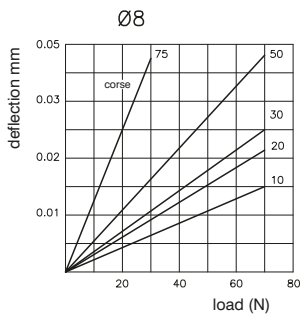
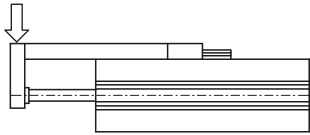

With side moment under static conditions completely extended and with load applied as indicated by the arrow

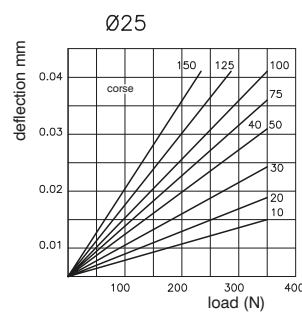
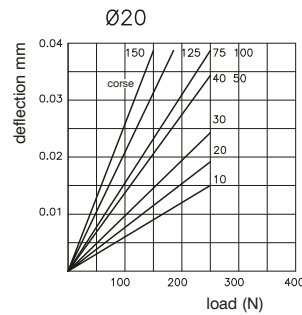
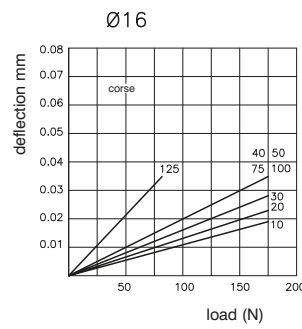
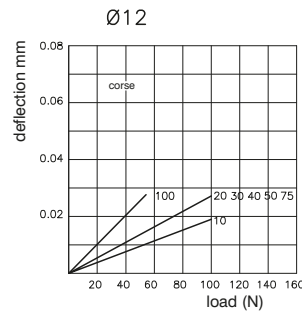
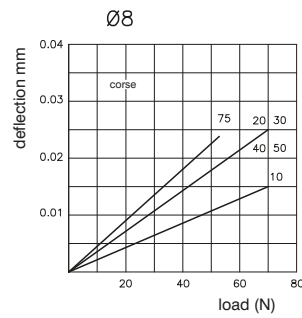
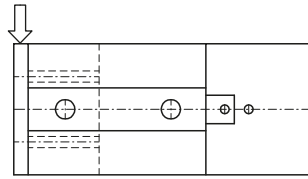

With misaligned side moment with load applied as indicated by the arrow at a distance "L" and with plate completely retracted.

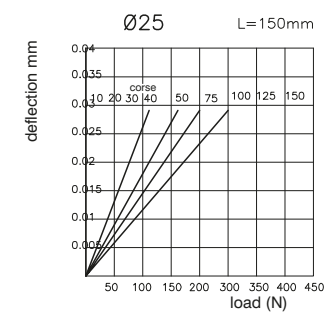
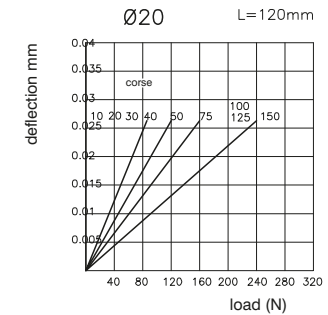
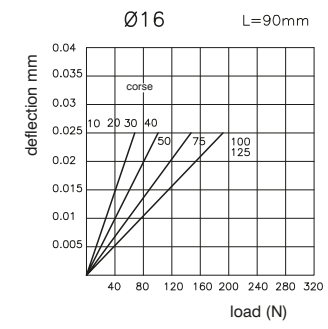
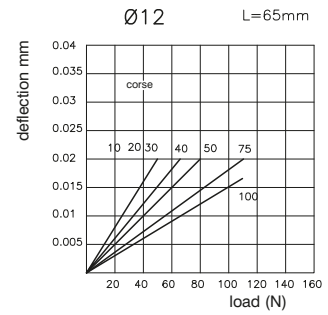
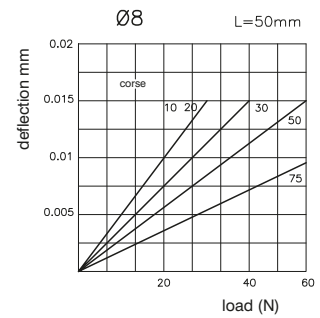
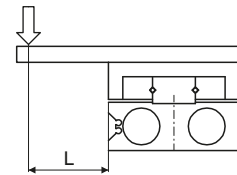

Accessories - Static moment  
Dimensions with dampers

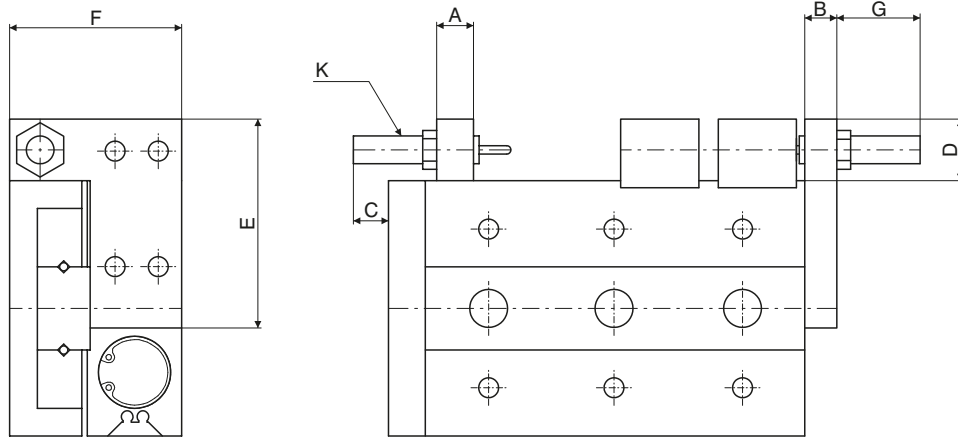

3

PNEUMATIC ACTUATION

Dimensions with adjusting screw

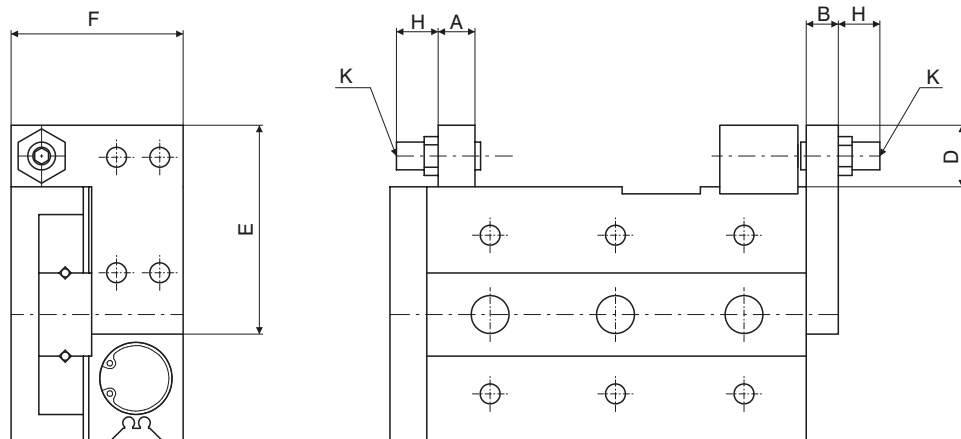

Bore	A	B	C	D	E	F	G max.	H max.	K
Ø8	7	8	26	14,5	38,5	23	25,5	28,5	M8x1
Ø12	9,5	8	21	15	45	31,5	24,5	32	M8x1
Ø16	11	10	19	18	55	37,5	29	34,5	M10x1
Ø20	13	12	28	24,5	70	47,5	42,5	35,5	M14x1,5
Ø25	16	15	34	24,5	80	54,5	39,5	37,5	M14x1,5

► Shock absorber mounting block / front stroke adjusting screw

Ordering code  
**6600.Ø.SU**

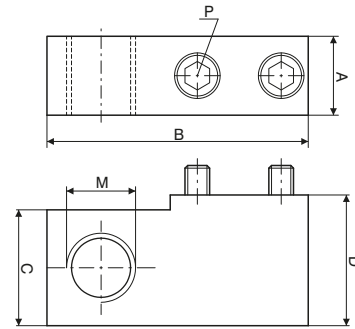

Bore	A	B	C	D	M	P
Ø8	7	23	14	15,5	M8x1	M3x16
Ø12	9,5	31	14,5	16		M4x16
Ø16	11	37	17,5	19	M10x1	M5x18
Ø20	13	45,5	23,5	26	M14x1,5	M6x25
Ø25	16	53,5		26,5		M8x25

► Reference block

Ordering code  
**6600.Ø.SI**

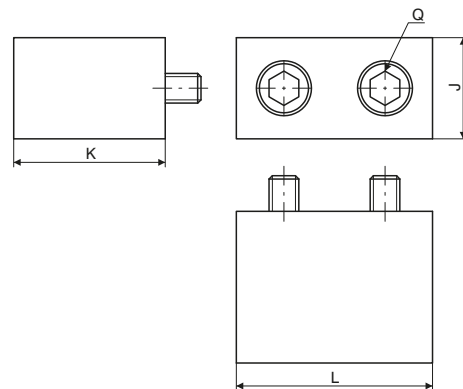
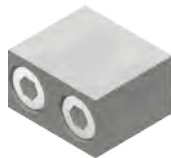

Bore	J	K	L	Q
Ø8	7	15,5	14,6	M3x16
Ø12	10	15	18,5	M4x14
Ø16	12	18,5	21	M5x18
Ø20	13	25,5	25	M6x25
Ø25	17		31	M8x25

► Shock absorber mounting block / rear stroke adjusting screw

Ordering code  
**6600.Ø.SR**

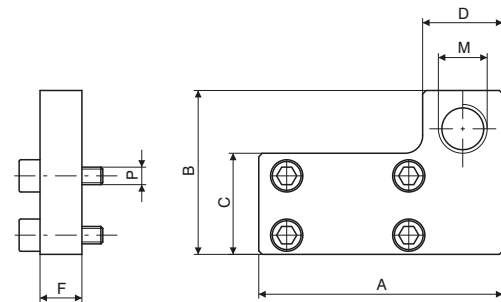

Bore	A	B	C	D	F	M	P
Ø8	38	23	12,5	14	8	M8x1	M3x12
Ø12	45	31	18				M4x12
Ø16	55	37	23,5	16	10	M10x1	M5x14
Ø20	70	47	29	23	12	M14x1,5	M5x16
Ø25	80	54	35		15		M6x20

► Adjusting screw

Ordering code  
**6600.Ø.VR**

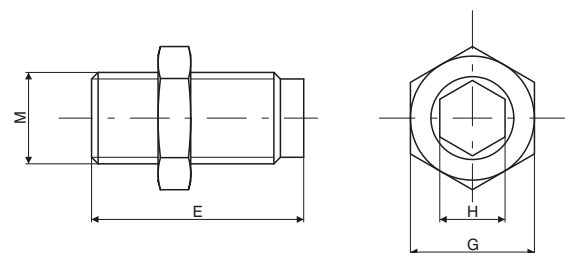

Bore	E	G	H	M
Ø8	36,5	12	4	M8x1
Ø12	40		5	
Ø16	44,5	14	5	M10x1
Ø20	47,5	22	8	M14x1,5
Ø25	52,5			



## Series 6200 - Twin-rod slide units

---

### General

#### TWIN-ROD SLIDE UNITS SERIES 6200 AND 6210

The 6200 series twin-rod linear guide units are wide cylinders used in manipulation applications and are characterised by their high force output thanks to their double piston design.

Bores range from 10mm to 32mm diameter, with sintered bronze bearings for standard applications and linear ball bearings for more rugged applications.

One major characteristic of these cylinders is the precision of their anti-rotational design, with the possibility of regulating the stroke to within 0.5mm.

When using magnetic sensors, the 1580 series sensor sits entirely within the extrusion, resulting in a smooth profile.

The liner guided units range includes , alongside the conventional two rod version with flange series 6200 , also the through rod version with twin flanges series 6210

Thanks to the twin-rod, double yoke design of the 6210 series it is possible to either fix the body and use the ends of the rods, or alternatively to fix the rod ends and use the body as the moving part. The cylinder can be piped through the body or through the rods depending on the application.

Stroke limiting screws are fitted at either end of the stroke. The substitution of these screws with shock absorbers makes it possible to use the cylinder on higher velocity applications (up to 500mm/sec.) Slots are provided along the edge of these units to accommodate 1580 series miniature sensors.

► Twin-rod slide units



Ordering code

6200.Ø.stroke.

- 10
- 15
- 20
- 25
- 32

B = Control unit with bronze bush  
C = Control unit with bearing bush

Construction characteristics

Body	anodised aluminium
Rods	C43 chromed steel (control unit with bronze bush) tempered and chromed steel (control unit with bearing bush)
Piston	aluminium
Rod bushing	brass
End cap	anodised aluminium
Piston seal	oil resistant NBR rubber
Piston rod seal	PUR
Plate	anodised aluminium

Operational characteristics

Function	double acting
Fluid	Filtered air. No lubrication needed, if applied it shall be continuous.
Max. pressure	7 bar
Working temperature	-5°C - +70°C
Cushioning	elastic bumper

Standard strokes

Bore	Stroke														
	10	15	20	25	30	35	40	45	50	60	70	75	80	90	100
Ø10	●	●	●	●	●	●	●	●	●	●	●	●			
Ø15	●	●	●	●	●	●	●	●	●	●	●	●	●	●	●
Ø20	●	●	●	●	●	●	●	●	●	●	●	●	●	●	●
Ø25	●	●	●	●	●	●	●	●	●	●	●	●	●	●	●
Ø32	●	●	●	●	●	●	●	●	●	●	●	●	●	●	●

**Overall dimensions Ø10 - Ø15**

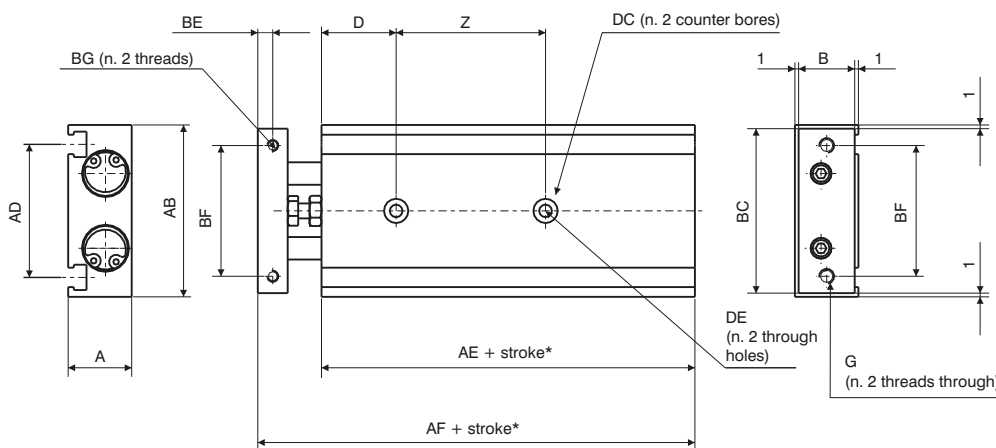
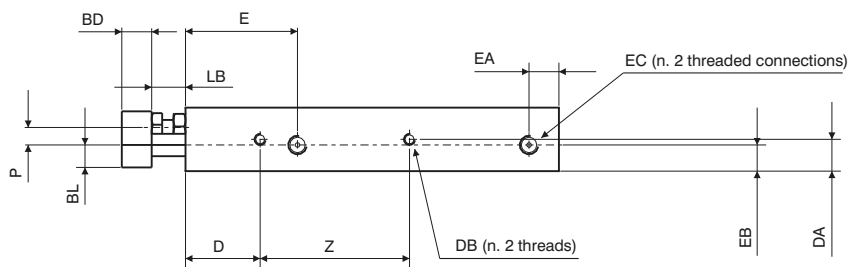
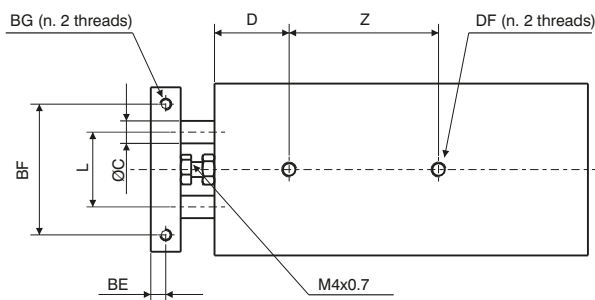
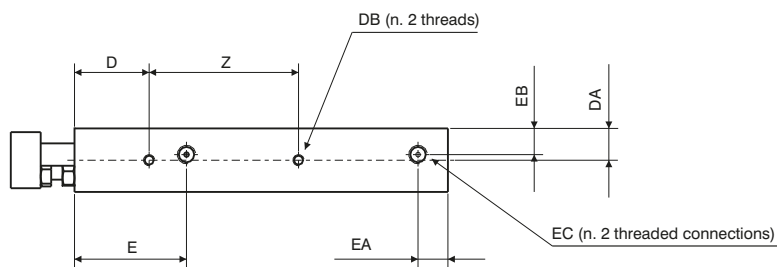

\*Dimensions only refer to the "standard stroke"

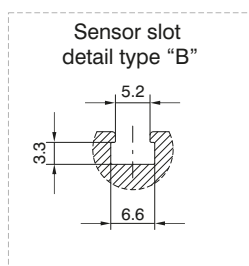

Bore	Ø10	Ø15	
<b>A</b>	17	20	
<b>AB</b>	46	58	
<b>AD</b>	35,6	48	
<b>AE</b>	55	60	
<b>AF</b>	72	79	
<b>B</b>	15	18	
<b>BC</b>	44	56	
<b>BD</b>	8	10	
<b>BE</b>	4	5	
<b>BF</b>	35	45	
<b>BG</b>	M3x0,5	M4x0,7	
Useful depth	5	6	
<b>BL</b>	6	9	
<b>C</b>	6	8	
<b>D</b>	20	30	
<b>DA</b>	8,5	10	
<b>DB</b>	M3x0,5	M4x0,7	
Useful depth	4,5	5	
<b>DC</b>	6,5	8	
depth	3,3	4,4	
<b>DE</b>	3,4	4,3	
<b>DF</b>	M4x0,7	M5x0,8	
Useful depth	7	8	
<b>E</b>	30	38,5	
<b>EA</b>	8	8	
<b>EB</b>	7	10	
<b>EC</b>	M5x0,8	M5x0,8	
Useful depth	4,5	4,5	
<b>F</b>	M4x0,7	M4x0,7	
<b>G</b>	M4x0,7	M5x0,8	
<b>L</b>	20	25	
<b>LB</b>	9	9	
<b>P</b>	4,7	4,5	
<b>Z</b> stroke	10 - 25	30	25
	30 - 50	40	35
	60 - 75	50	45
	80	-	45
	90-100	-	55



Overall dimensions Ø20 - Ø25 - Ø32

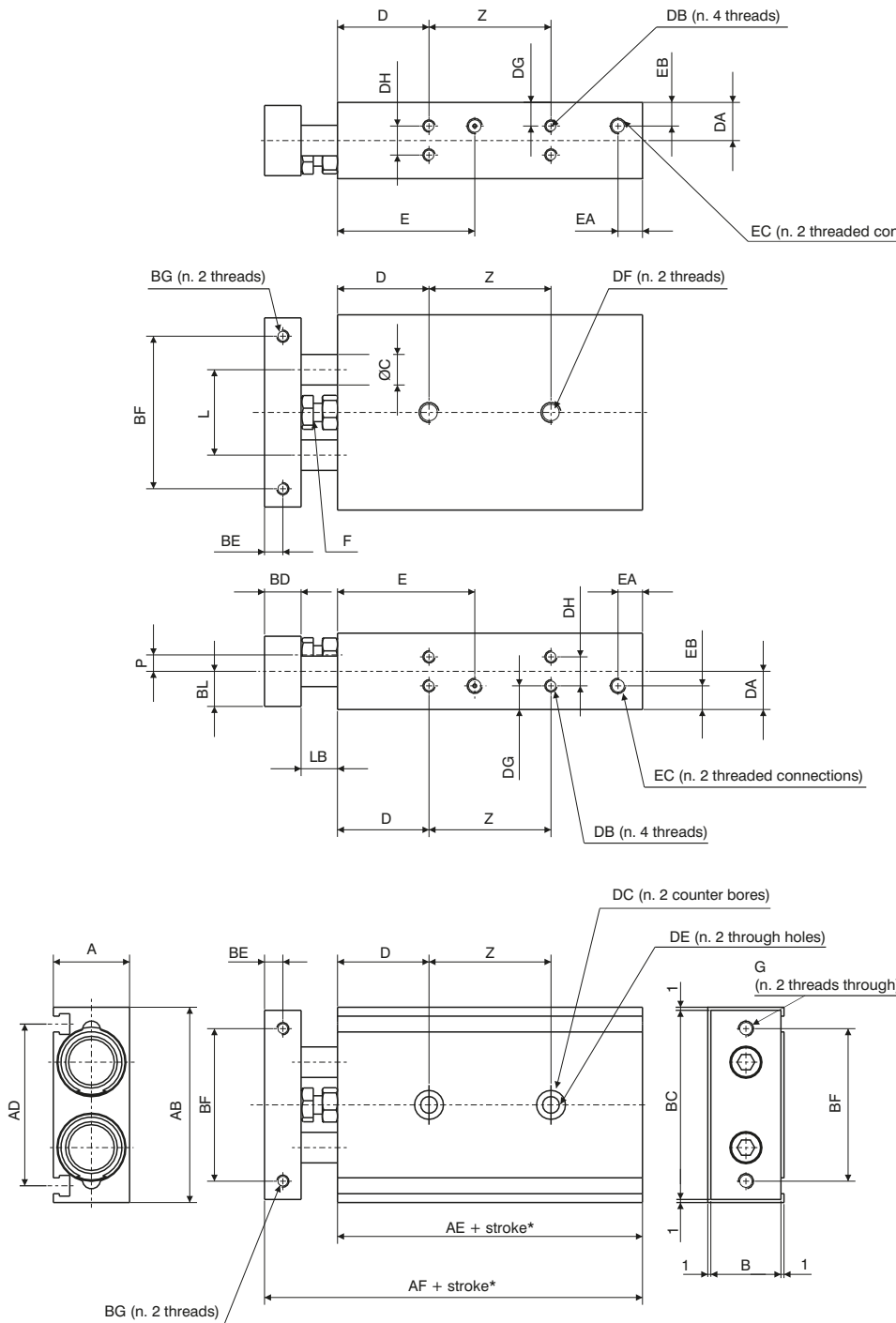

\*Dimensions only refer to the "standard stroke"

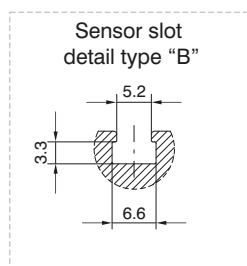

Bore		Ø20	Ø25	Ø32
<b>A</b>		25	30	38
<b>AB</b>		64	80	98
<b>AD</b>		53	64	76
<b>AE</b>		70	72	82
<b>AF</b>		94	96	112
<b>B</b>		23	28	36
<b>BC</b>		62	78	96
<b>BD</b>		12	12	16
<b>BE</b>		6	6	8
<b>BF</b>		50	60	75
<b>BG</b>		M4x0,7	M5x0,8	M5x0,8
	Useful depth	6	7,5	8
<b>BL</b>		11,5	14	18
<b>C</b>		10	12	16
<b>D</b>		30	30	30
<b>DA</b>		12,5	15	19
<b>DB</b>		M4x0,7	M5x0,8	M5x0,8
	Useful depth	6	7,5	7,5
<b>DC</b>		9,5	11	11
	depth	5,3	6,3	6,3
<b>DE</b>		5,5	6,9	6,9
<b>DF</b>		M6x1	M8x1,25	M8x1,25
	Useful depth	10	12	12
<b>DG</b>		7,75	8,5	9
<b>DH</b>		9,5	13	20
<b>E</b>		45	46	56
<b>EA</b>		8	9	10
<b>EB</b>		7,75	15	19
<b>EC</b>		M5x0,8	G1/8	G1/8
	Useful depth	4,5	6,5	6,5
<b>F</b>		M6x1	M6x1	M8x1,25
<b>G</b>		M5x0,8	M6x1	M6x1
<b>L</b>		28	35	44
<b>LB</b>		12	12	14
<b>P</b>		5,4	7,8	12
<b>Z</b>	stroke	10 - 25	30	30
		30 - 50	40	40
		60 - 100	60	60



Operating instructions

3 PNEUMATIC ACTUATION

		Bore								
		Ø10	Ø15	Ø20	Ø25	Ø32				
Stroke	<b>Control unit with bronze bush</b>						<b>Weight g</b>			
10	150	250	400	610	1150					
15	160	265	420	635	1190					
20	170	280	440	660	1230					
25	180	290	460	690	1275					
30	190	300	480	720	1320					
35	200	315	495	745	1360					
40	210	330	510	770	1400					
45	220	345	530	800	1450					
50	230	360	550	830	1490					
60	250	390	585	890	1580					
70	270	420	620	950	1665					
75	280	435	640	970	1710					
80		450	660	995	1755					
90		480	700	1060	1840					
100		510	740	1000	1930					
Stroke	<b>Control unit with bearing bush</b>									
10	160	270	430	620	1160					
15	165	285	445	645	1205					
20	170	300	460	670	1250					
25	180	310	480	700	1295					
30	190	320	500	730	1340					
35	200	335	515	755	1380					
40	210	350	530	780	1420					
45	220	365	550	810	1465					
50	230	380	570	840	1510					
60	250	410	605	895	1595					
70	270	440	640	955	1680					
75	280	455	660	980	1720					
80		470	680	1005	1765					
90		500	715	1065	1855					
100		530	750	1110	1940					
Working pressure	<b>Theoretical slide force</b>									
1 bar	16	10	35.5	25	63	47	98	75.5	161	120.5
1.5 bar	23.5	15	53	38	94	62.5	147.5	113.5	241	181
2 bar	31.5	20.0	70.5	50.5	125.5	94	196.5	151	321.5	241
3 bar	47	30	106	75.5	188.5	141	294.5	227	482.5	362
4 bar	63	40	141	101	251	188	393	302.5	643	482.5
5 bar	78.5	50	176.5	126	314	236	491	378	804	603
6 bar	94	60	212	151	377	283	589	453.5	965	723.5
7 bar	110	70	247	176.5	440	330	687.5	529	1125.6	844
	Out	In	Out	In	Out	In	Out	In	Out	In

Operating instructions

Possible loads

Control unit with bronze bush

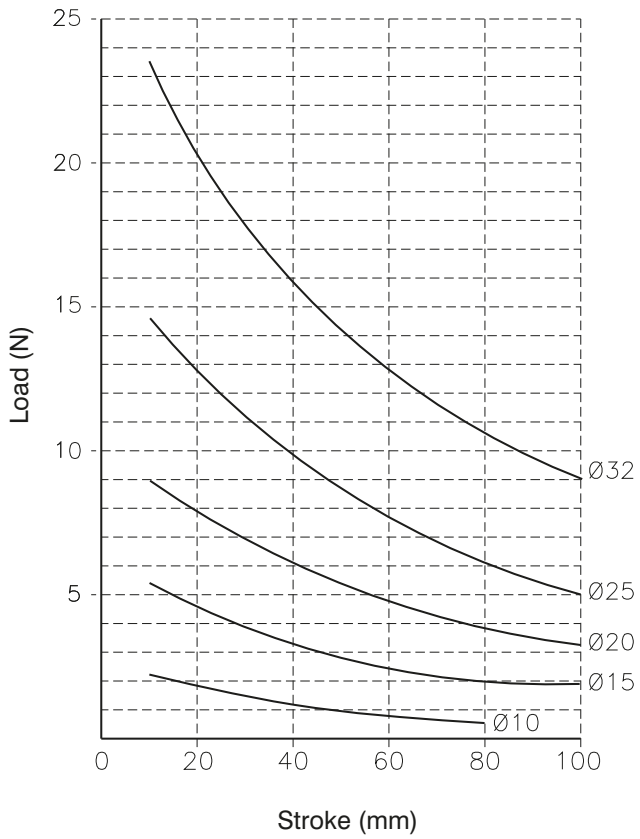

Control unit with bearing bush

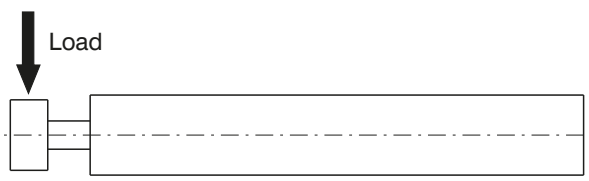
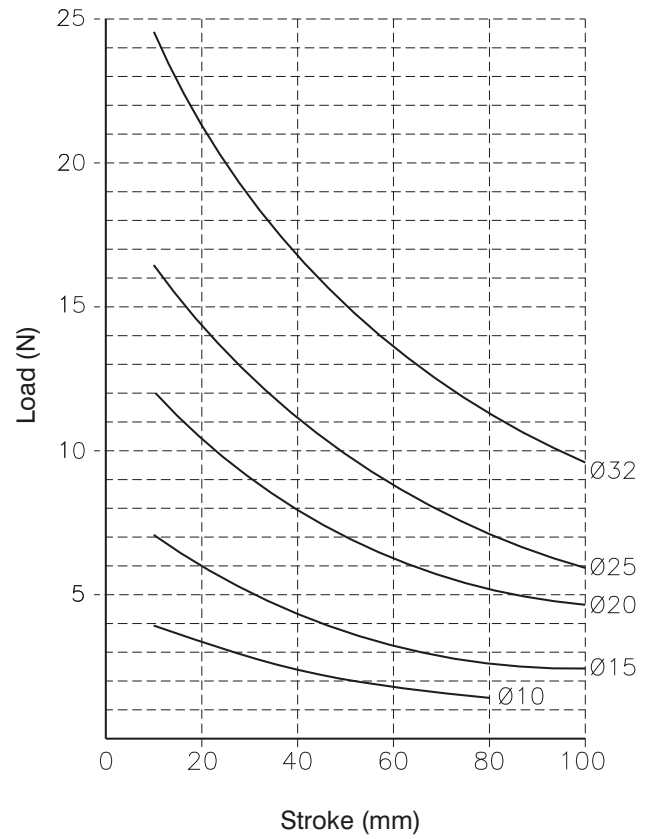

Twin-rod slide units



Ordering code

6200.Ø.stroke.  
 10  
 15  
 20  
 25  
 32  
 B = Control unit with bronze bush  
 C = Control unit with bearing bush

Construction characteristics

Body	anodised aluminium
Rods	C43 chromed steel (control unit with bronze bush) tempered and chromed steel (control unit with bearing bush)
Piston	aluminium
Rod bushing	brass
End plate	anodised aluminium
Piston seal	oil resistant NBR rubber
Piston rod seal	PUR
Plate	anodised aluminium

Technical characteristics

Function	double acting
Fluid	Filtered air. No lubrication needed, if applied it shall be continuous.
Max. pressure	7 bar
Working temperature	-5°C - +70°C
Cushioning	elastic bumper

Standard strokes

Bore	Stroke														
	10	15	20	25	30	35	40	45	50	60	70	75	80	90	100
Ø10	●	●	●	●	●	●	●	●	●	●	●	●			
Ø15	●	●	●	●	●	●	●	●	●	●	●	●	●	●	●
Ø20	●	●	●	●	●	●	●	●	●	●	●	●	●	●	●
Ø25	●	●	●	●	●	●	●	●	●	●	●	●	●	●	●
Ø32	●	●	●	●	●	●	●	●	●	●	●	●	●	●	●

Overall dimensions Ø10

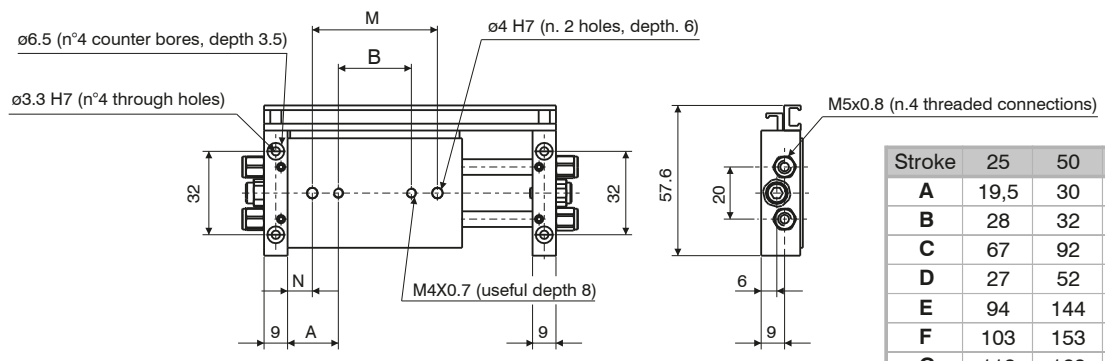
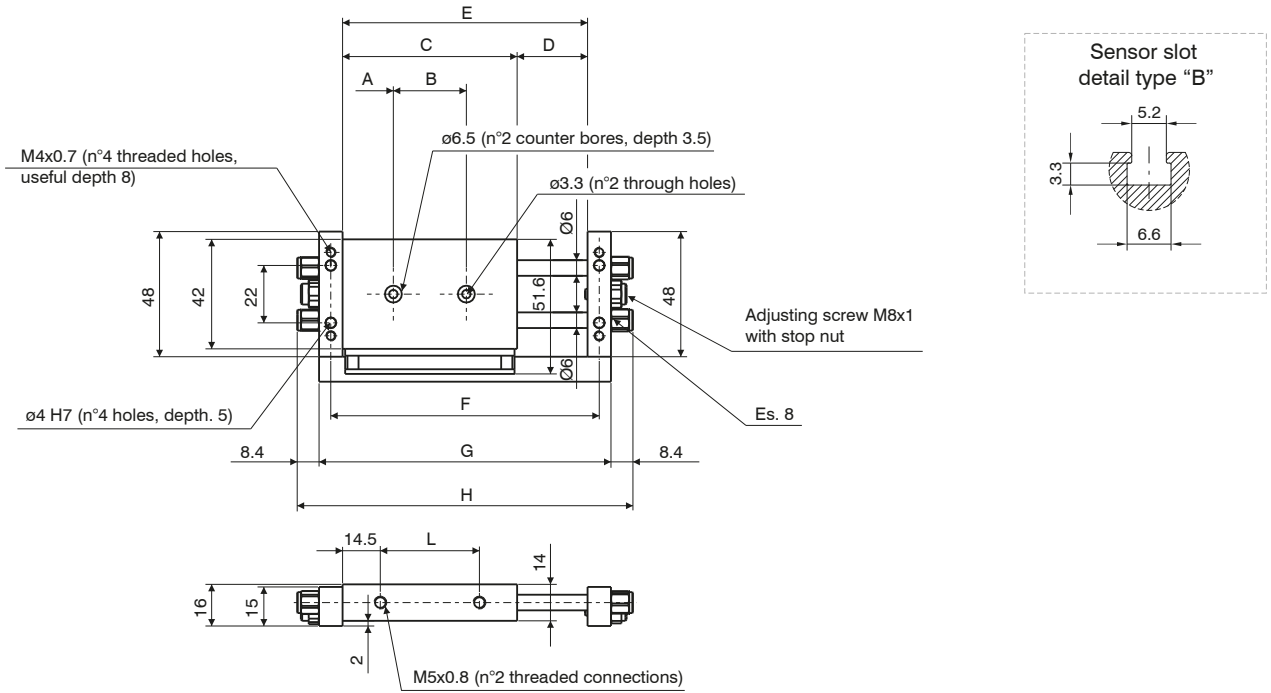

Stroke	25	50	75	100
A	19,5	30	35	35
B	28	32	47	72
C	67	92	117	142
D	27	52	77	102
E	94	144	194	244
F	103	153	203	253
G	112	162	212	262
H	129	179	229	279
L	38	63	88	113
M	48	52	67	92
N	9,5	20	25	25
<b>Weight</b>				
g	160	230	280	310

MOUNTING WITH FIXED PLATE

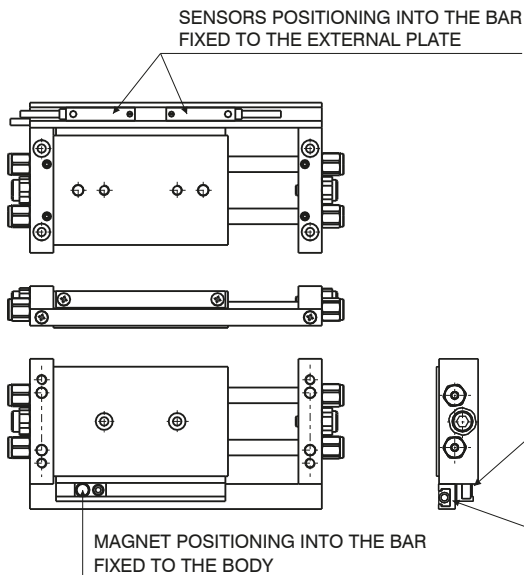

MOUNTING WITH A FIXED BODY

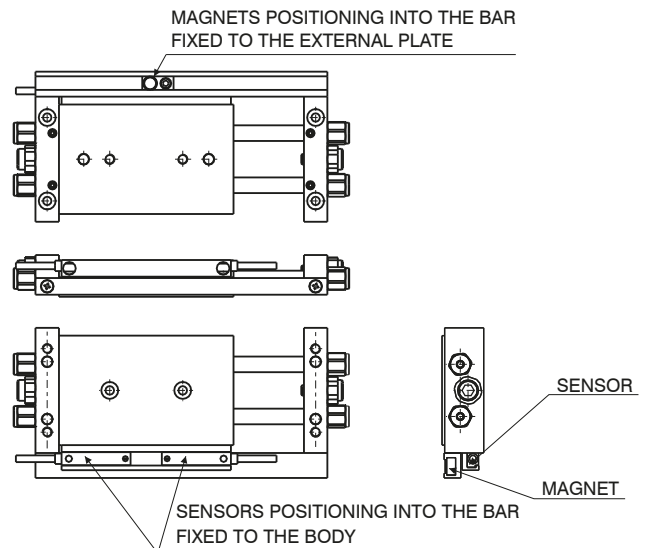

**Overall dimensions Ø15**

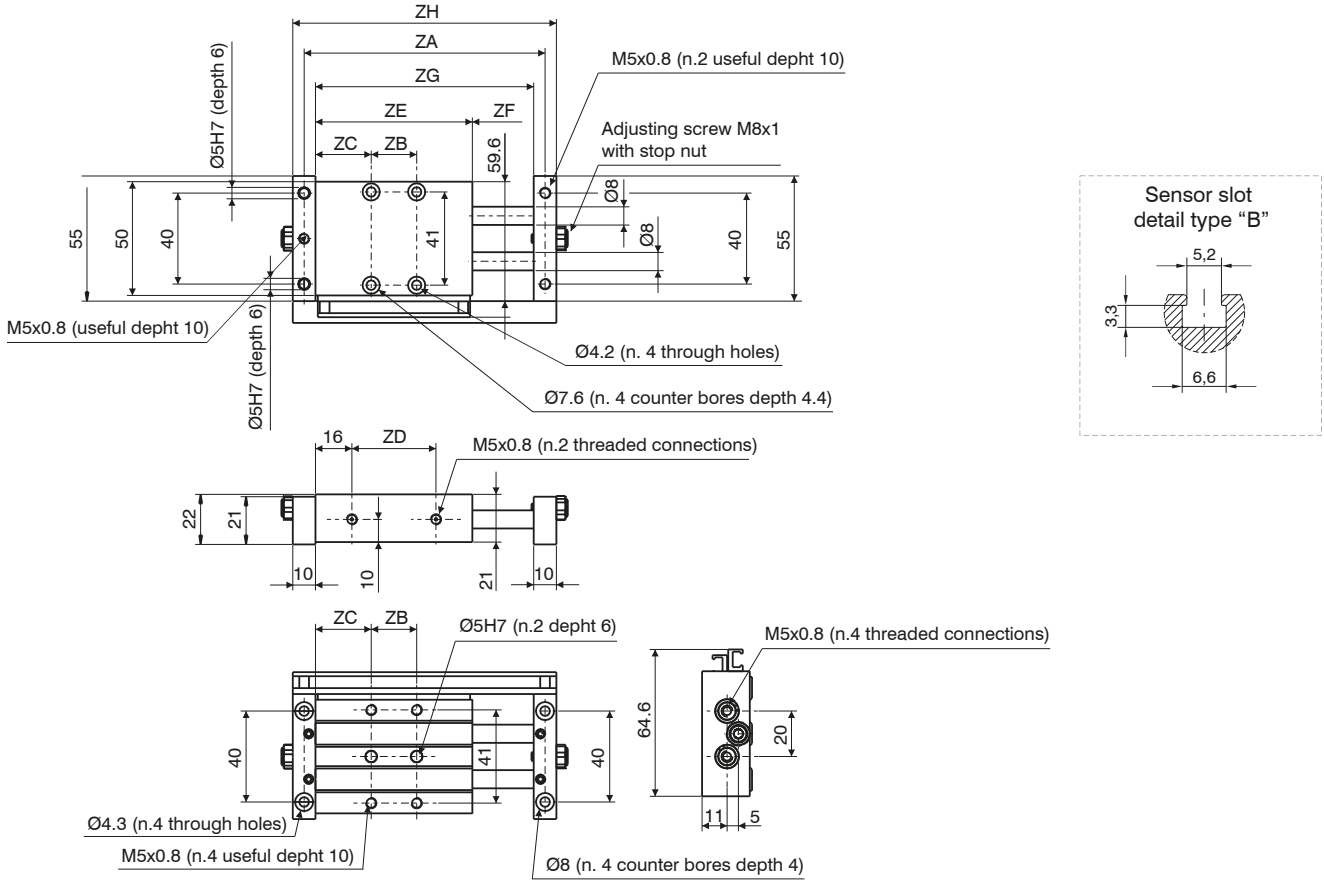

Stroke	25	50	75	100	125	150	175	200
<b>ZA</b>	106	156	206	256	306	356	406	456
<b>ZB</b>	20	45	65	90	90	90	90	90
<b>ZC</b>	24,5	24,5	27	27	39,5	52	64,5	77
<b>ZD</b>	37	62	87	112	137	162	187	212
<b>ZE</b>	69	94	119	144	169	194	219	244
<b>ZF</b>	27	52	77	102	127	152	177	202
<b>ZG</b>	96	146	196	246	296	346	396	446
<b>ZH</b>	116	166	216	266	316	366	416	466
<b>Weight</b>								
g	240	350	450	550	670	750	900	1000

**MOUNTING WITH FIXED PLATE**

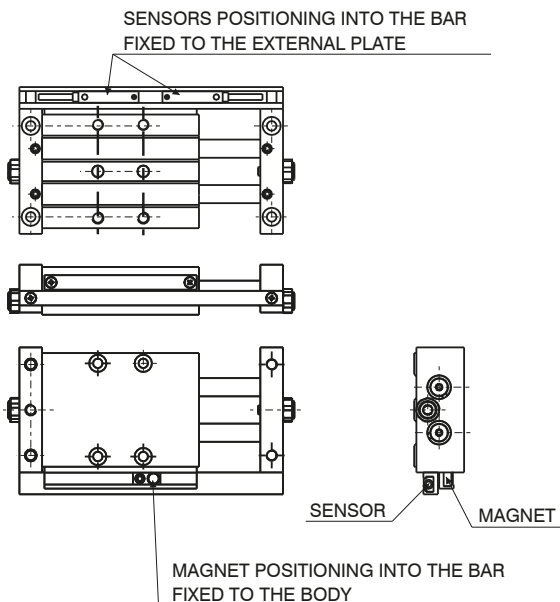

**MOUNTING WITH FIXED BODY**

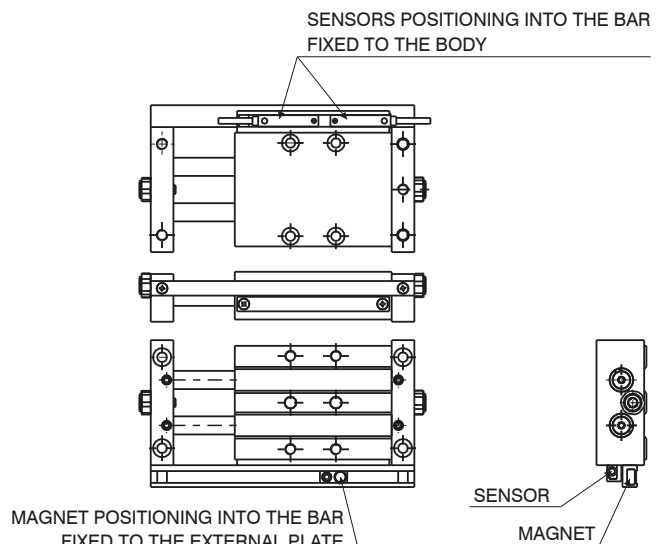

Overall dimensions Ø25

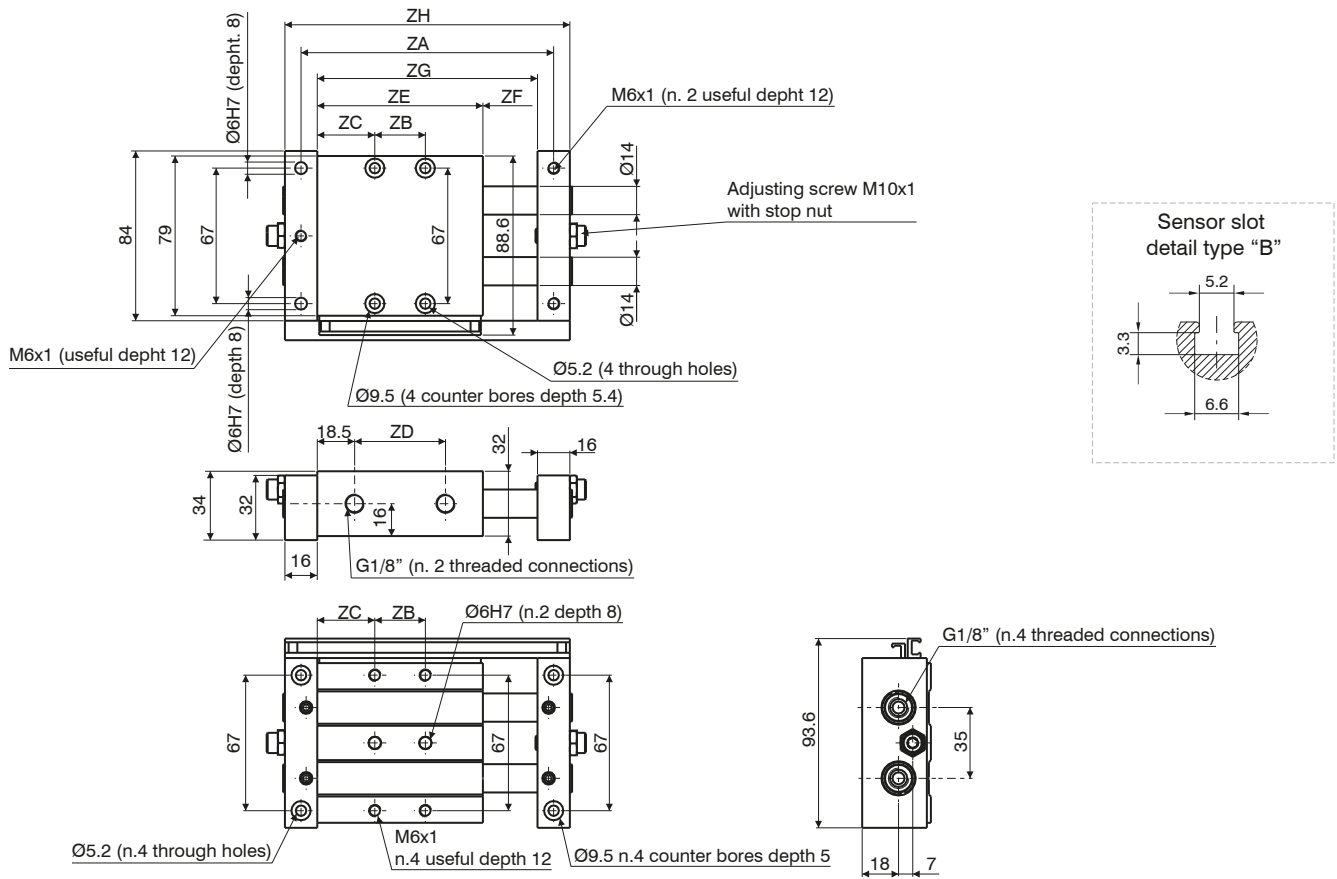

Stroke	25	50	75	100	125	150	175	200
<b>ZA</b>	125	175	225	275	325	375	425	475
<b>ZB</b>	25	45	65	90	90	90	90	90
<b>ZC</b>	28,5	31	33,5	33,5	46	58,5	71	83,5
<b>ZD</b>	45	70	95	120	145	170	195	220
<b>ZE</b>	82	107	132	157	182	207	232	257
<b>ZF</b>	27	52	77	102	127	152	177	202
<b>ZG</b>	109	159	209	259	309	359	409	459
<b>ZH</b>	141	191	241	291	341	391	441	491
<b>Weight</b>								
g	950	1140	1350	1600	1800	2000	2300	2500

MOUNTING WITH FIXED PLATE

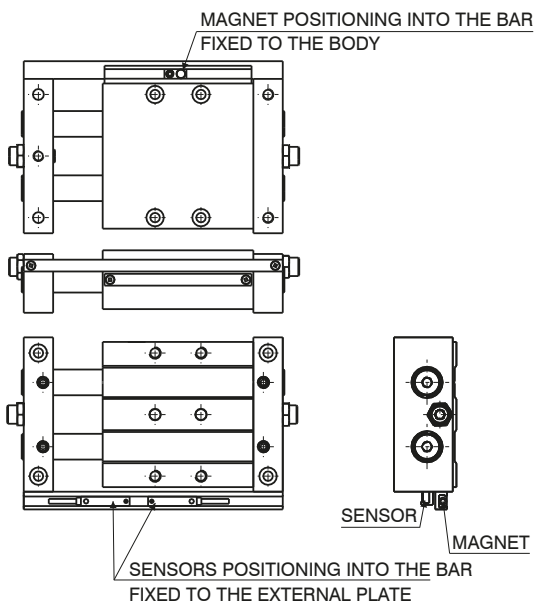

MOUNTING WITH FIXED BODY

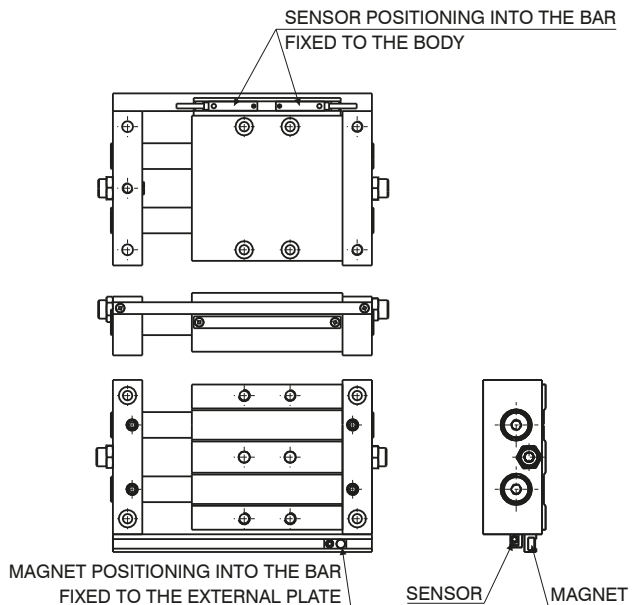

**Operating conditions**

**Theoretical force (N)**

Working pressure	Bore		
	Ø10	Ø15	Ø25
2 bar	20	41	119
3 bar	30	62	179
4 bar	40	83	239
5 bar	51	104	299
6 bar	61	124	358
7 bar	71	145	418
8 bar	81	166	478
9 bar	91	186	537
	101	207	597
	Effective area (mm <sup>2</sup> )		

**Deflection of piston rods**

Applied load to body centre

Bore	Load	Deflection (mm)	
Ø10	10 N	0,07	/
Ø15	30 N	0,08	0,28
Ø25	60 N	0,02	0,08
		100	200
		Stroke	

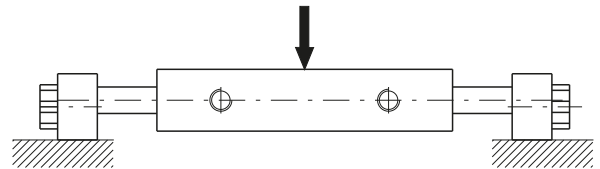

Applied load to body end

Bore	Load	Deflection (mm)			
Ø10	3 N	0,06	0,3	/	/
Ø15	5 N	0,1	0,2	0,5	1
Ø25	10 N	0,03	0,1	0,15	0,25
		50	100	150	200
		Stroke			

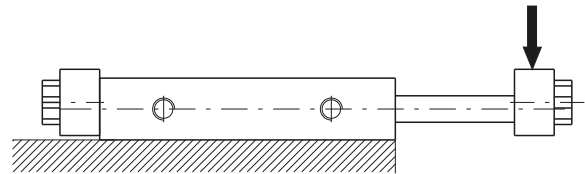

**Control unit with bronze bushes**

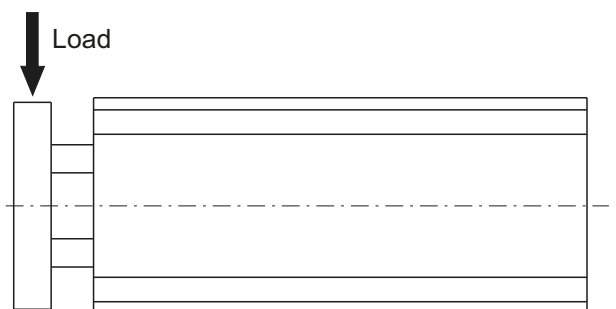
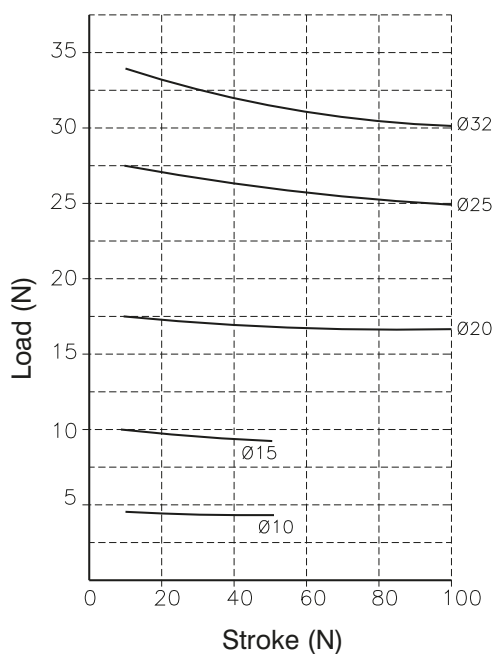

3

PNEUMATIC ACTUATION





Overall dimensions - Ø16

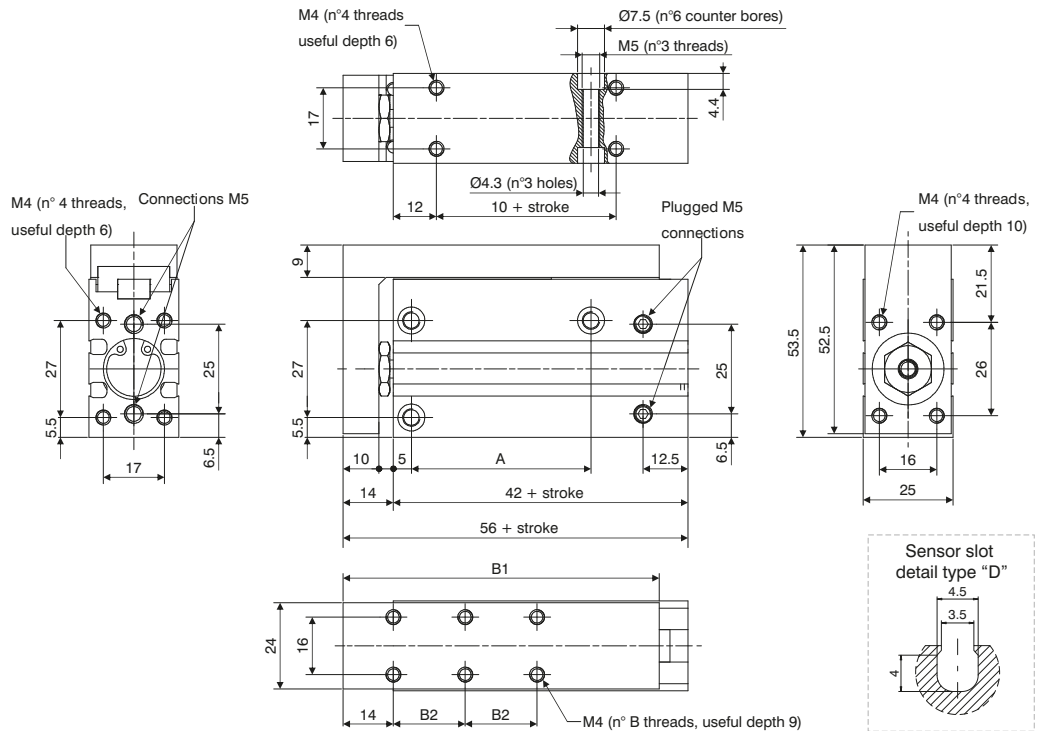

Table of dimensions

	Standard strokes								
	5	10	15	20	25	30	40	50	60
A	20	30	40	50	60				
B1	58	68	78	88	98	108			
B2	10	20	30	20	25	30			
B	4						6		
Weight (g)	215	230	250	260	280	290	325	350	390

Overall dimensions - Ø20

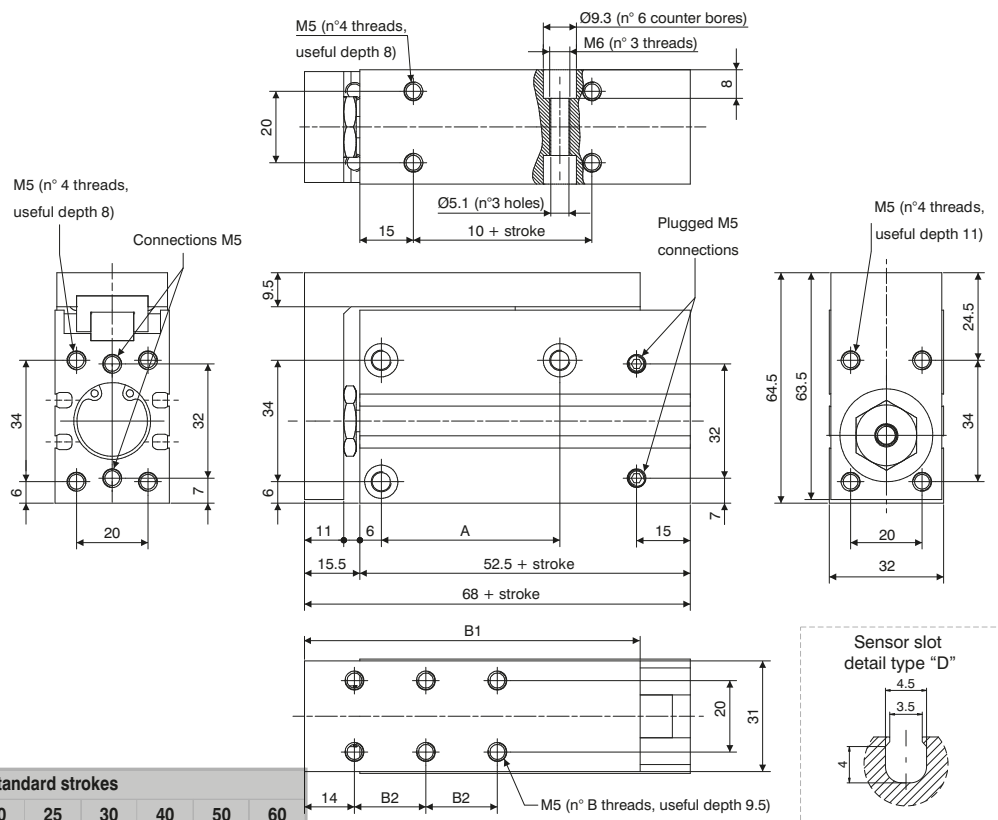
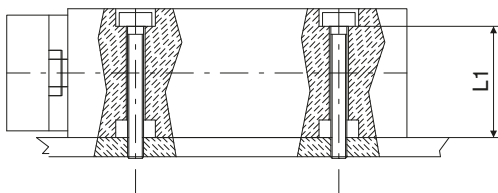

Table of dimensions

	Standard strokes								
	5	10	15	20	25	30	40	50	60
A	20	25	40	50	70				
B1	64	74	84	94	104	114			
B2	10	20	30	20	25	30			
B	4						6		
Weight (g)	440	455	490	505	540	560	600	660	700

Fixing - Load

LATERAL (THROUGH SCREW)



	SCREW	Maximum torque (Nm)	L1
Ø10	M4	2.5	15.6
Ø16	M4	2.5	20.6
Ø20	M5	5.1	24

LATERAL (THREADED HOLE)

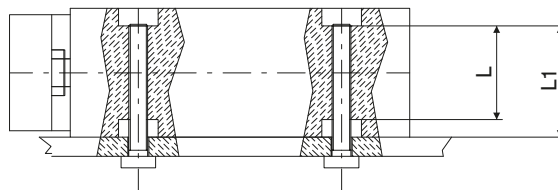

	SCREW	Maximum torque (Nm)	L1	L
Ø10	M5	5.1	15.6	11.2
Ø16	M5	5.1	20.6	16.2
Ø20	M6	8.1	24	16

VERTICAL (THREADED HOLE)

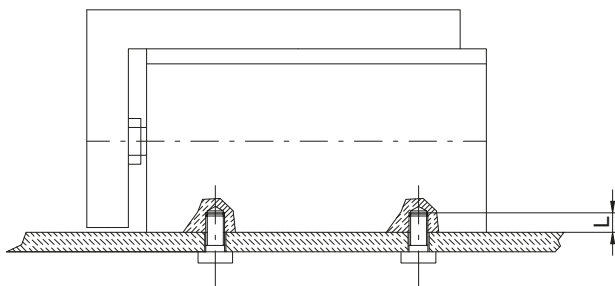

	SCREW	Maximum torque (Nm)	L
Ø10	M4	2.5	6
Ø16	M4	2.5	6
Ø20	M5	5.1	8

AXIAL (THREADED HOLE)

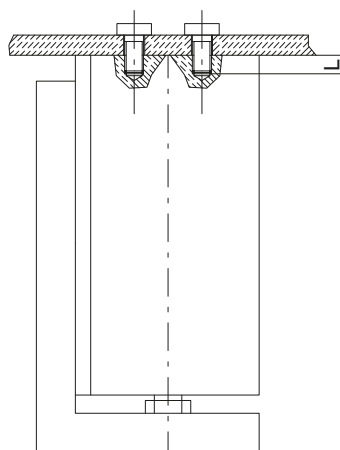

	SCREW	Maximum torque (Nm)	L
Ø10	M4	2.5	6
Ø16	M4	2.5	6
Ø20	M5	5.1	8

LOAD

FRONTAL MOUNTING

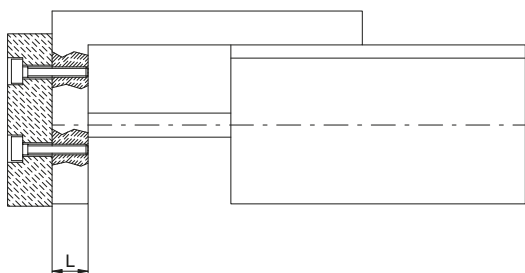

	SCREW	Maximum torque (Nm)	L
Ø10	M4	2.5	7.5
Ø16	M4	2.5	10
Ø20	M5	5.1	11

BACK MOUNTING

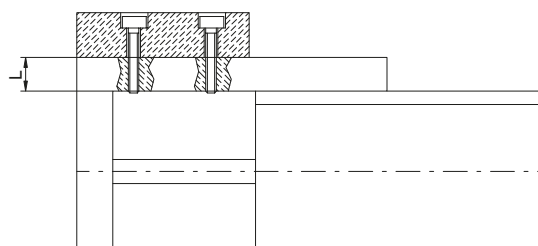

	SCREW	Maximum torque (Nm)	L
Ø10	M4	2.5	8
Ø16	M4	2.5	9
Ø20	M5	5.1	9.5

Fixing - Load

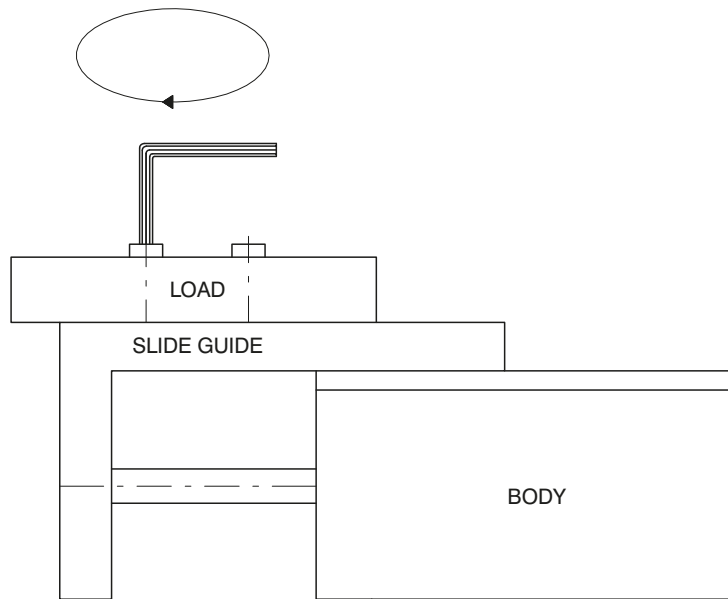

ATTENTION : Slide must be blocked before fixing the load  
this operation should not be done by blocking the body as the  
guide could get damaged.

CONNECTION BETWEEN PLATE AND ROD

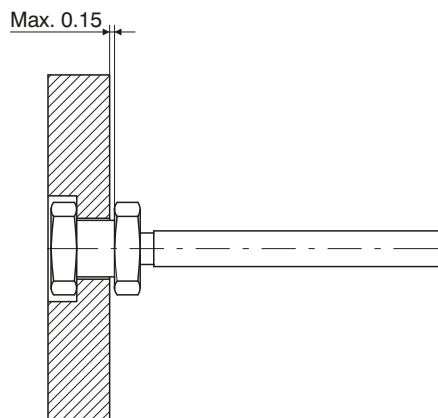

The fluctuating connection, maximum clearance 0.15mm as indicated by the arrow



Plate deflection graphs

Plate deviation (arrow) when the load is applied on the spot indicated with the arrow and the unit completely extended

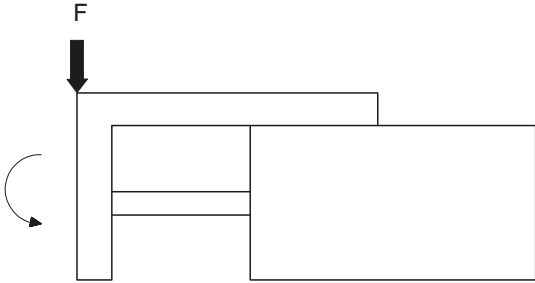
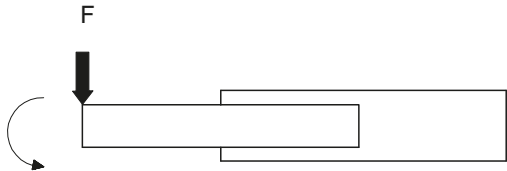
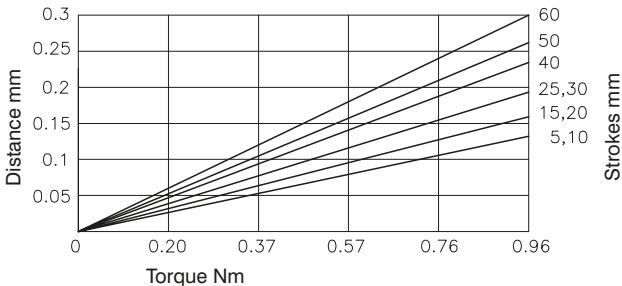

Plate deviation (arrow) when the load is applied on the spot indicated with the arrow and the unit completely extended



Ø10



Ø10

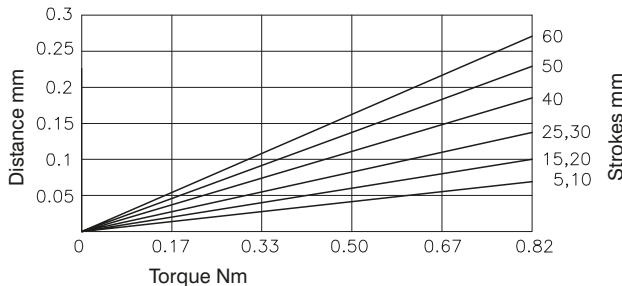

Ø16

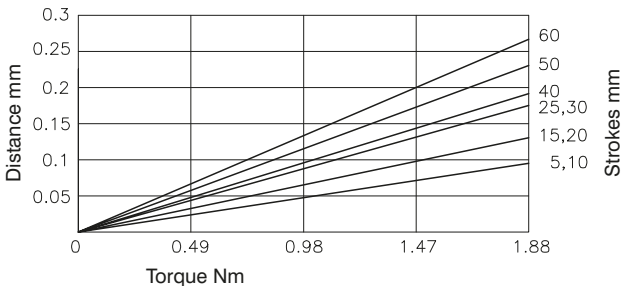

Ø16

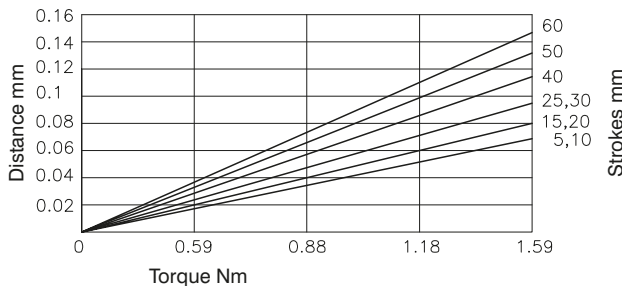

Ø20

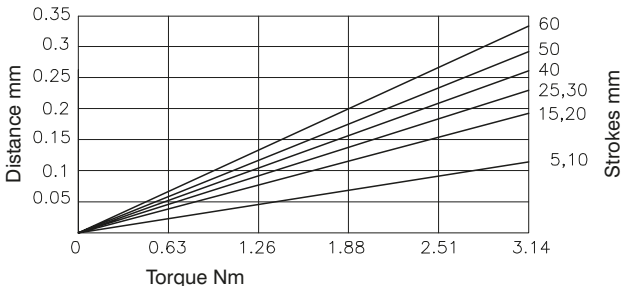

Ø20

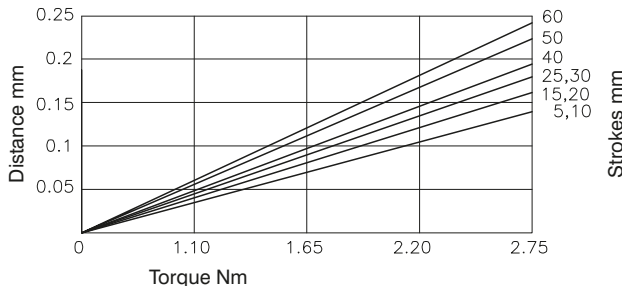

**Plate deflection graphs outer stroke - selection graphs**

Plate deviation (compared to A) when the load is applied on the spot indicated with the arrow and the unit completely extended

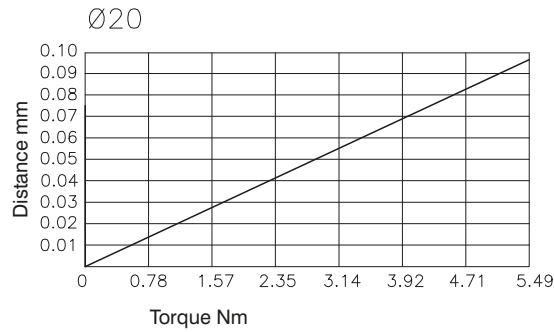
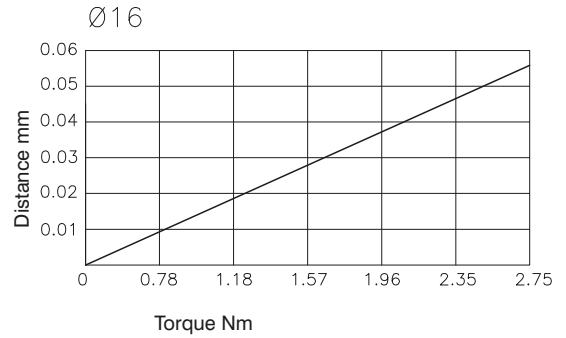
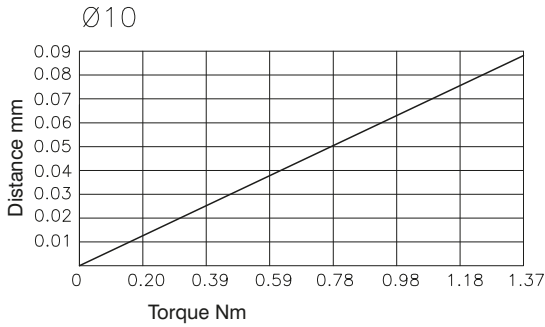
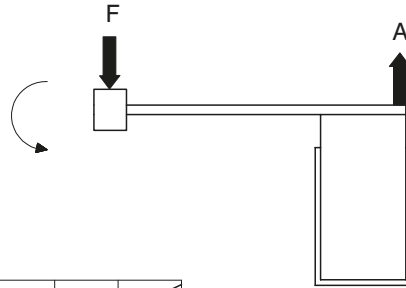

MOUNTING POSITION	VERTICAL			HORIZONTAL								
	100	200	300	100			200			300		
MAX. SPEED (mm/sec.)	100	200	300	50	100	200	50	100	200	50	100	200
Load eccentricity				50	100	200	50	100	200	50	100	200
Selection graphs	1	2	3	4	5	6	7	8	9	10	11	12

**Selection graphs 1 - 3 (vertical mounting)**

Drawing 1

Maximum speed 100 mm/s or lower

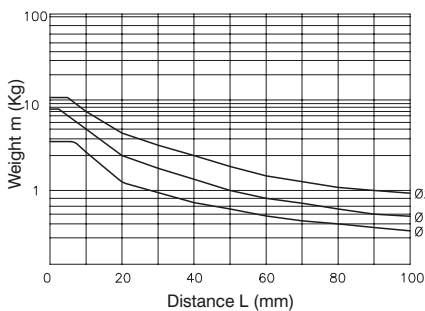

Drawing 2

Maximum speed 300 mm/s or lower

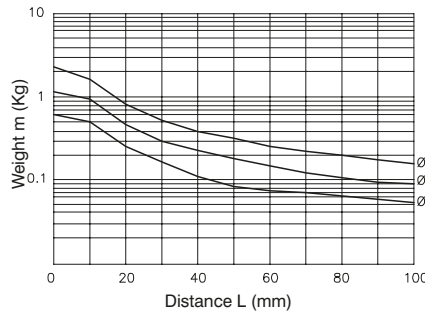

Drawing 3

Maximum speed 500 mm/s or lower

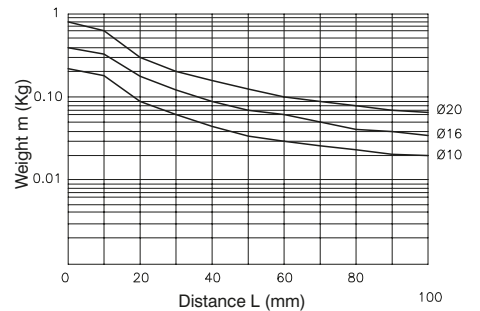



Selection graphs

Selection graphs 4 - 12 (horizontal mounting)

Drawing 4 load eccentricity 50mm  
Maximum speed 100 mm/s or lower

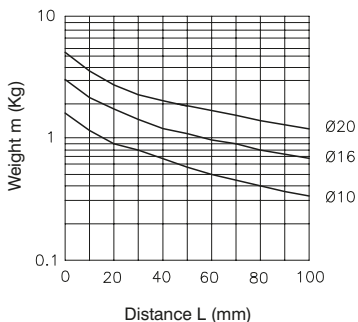

Drawing 7 load eccentricity 50mm  
Maximum speed 300 mm/s or lower

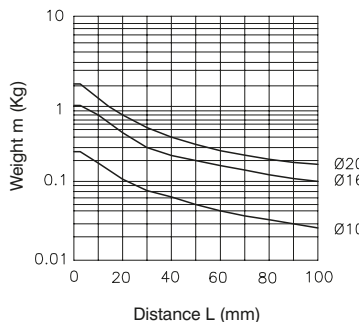

Drawing 10 load eccentricity 50mm  
Maximum speed 500 mm/s or lower

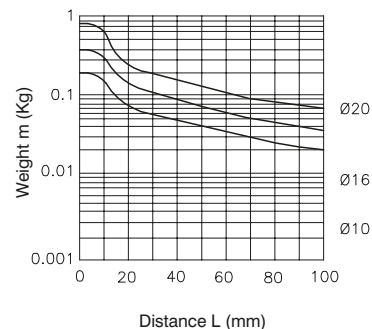

Drawing 5 load eccentricity 100mm  
Maximum speed 100 mm/s or lower

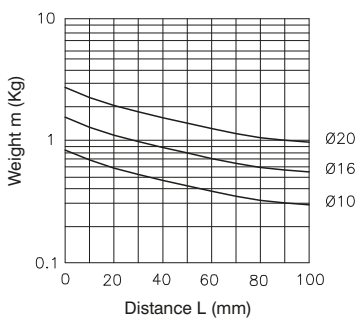

Drawing 8 load eccentricity 100mm  
Maximum speed 300 mm/s or lower

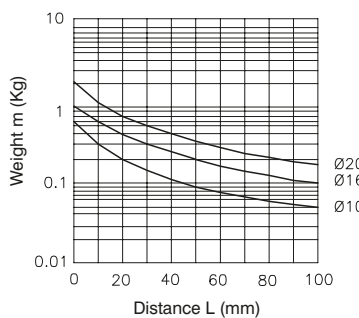

Drawing 11 load eccentricity 100mm  
Maximum speed 500 mm/s or lower

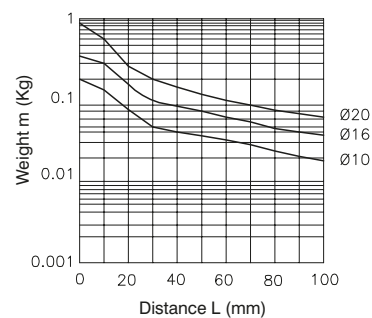

Drawing 6 load eccentricity 200mm  
Maximum speed 100 mm/s or lower

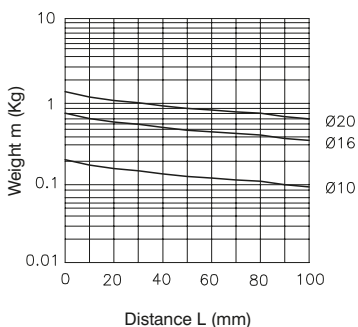

Drawing 9 load eccentricity 200mm  
Maximum speed 300 mm/s or lower

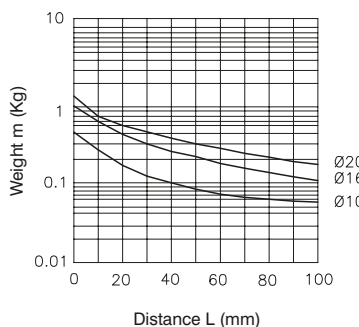

Drawing 12 load eccentricity 200mm  
Maximum speed 500 mm/s or lower

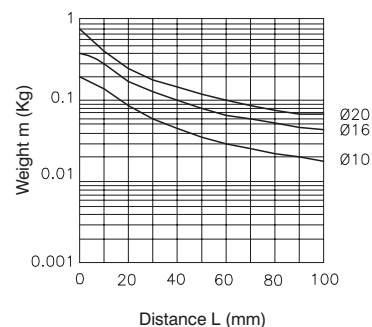

3 PNEUMATIC ACTUATION



## Series 1605, Mechanically coupled

### General

The purpose of producing a rodless cylinder is to provide a space saving option over conventional cylinders. On a traditional rod type cylinder, the total space occupied with rod out is more than double the length of the cylinder, while with rodless cylinder it is little more than its stroke. Profiled tube allows mounting of sensors 1500.\_, RS.\_, HS.\_ and 1580.\_, MRS.\_, MHS.\_ on the two sides of carriage, by means of suitable brackets. Standard accessories include foot mounting brackets for installation on cylinder and caps, intermediate mounting brackets to give support to long stroke cylinders under load (over one metre), an oscillating coupling device for installation between the mounting plate and the load and on request, a very precise external movement device.

### Construction characteristics

End covers	anodised aluminium
Barrel	anodised aluminium
Bands	tempered stainless steel
Mounting place	anodised aluminium
Piston	acetal resin
Guide blocks	acetal resin
Cushion bearings	aluminium
Piston seals	special 80 shore nitril mixture, wear resistant
Other seals	NBR oil-resistant rubber

### Caratteristiche di funzionamento

Fluid	Filtered air. No lubrication needed, if applied it shall be continuous.
Pressure	0.5 - 8 bar
Working temperature	-5°C - +70°C
Max. speed	1.5 m/sec. (normal working conditions)
Bores	Ø 25 - 32 - 40 - 50 - 63
Max. strokes	6 m

Please follow the suggestions below to ensure a long life for these cylinders:

- use clean and lubricated air
- Please adequately evaluate the load involved and its direction, especially in respect to the moving carriage (also see tables for loads and admitted moments).
- avoid high speeds together with long strokes and heavy loads: this would produce kinetic energy which the cylinder cannot absorb, especially if used as a limit stop (in this case use mechanical stop device)
- evaluate the environmental characteristics of cylinder used (high temperature, hard atmosphere, dust, humidity etc.)

**Please note: air must be dried for applications with lower temperature.**

Use hydraulic oils H class (ISO Vg32) for correct continued lubrication.

Our Technical Department will be glad to help.

For applications where a low smooth uniform operations speed is required, you must specify this on your purchase order so that we can use the proper special grease.

### Use and maintenance

This type of cylinder, due to its characteristics, has to be used within certain criteria. Correct use will give long and troublefree operation. Filtered and lubricated compressed air reduce seal wear. Verify that the load will not produce unforeseen stresses. Never combine high speed with heavy load. Always support the long stroke cylinder with intermediate brackets and never exceed the specified working conditions.

If maintenance is required, follow the instructions supplied with the repair kit.



► **Basic version**

Ordering code  
**1605.Ø.stroke.01.M**  
(Max. stroke 6 mt.)

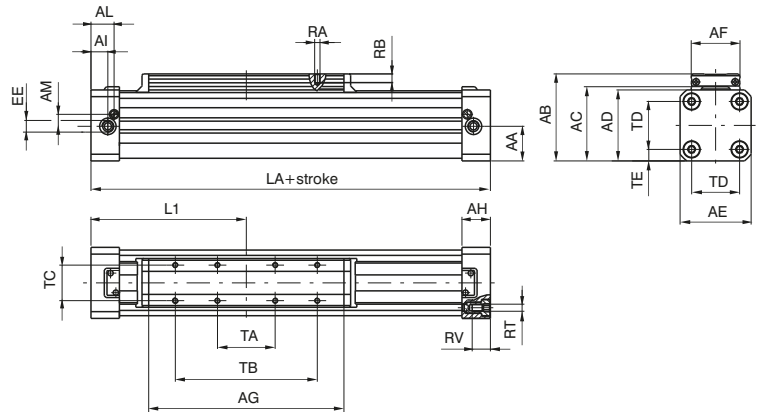

► **Left head**

Ordering code  
**1605.Ø.stroke.02.M**  
(Max. stroke 6 mt.)

Possibility of a single feed cylinder head

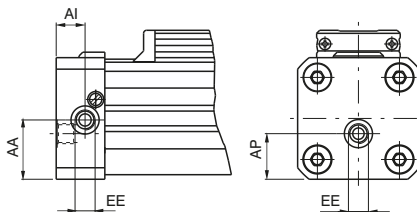

► **Right head**

Ordering code  
**1605.Ø.stroke.03.M**  
(Max. stroke 6 mt.)

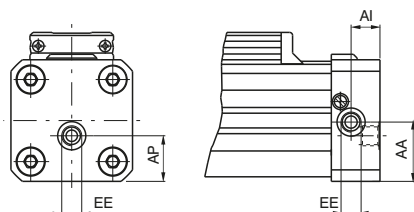

Bore	25	32	40	50	63	
AA	19,5	25,5	31	39	46,5	
AB	56	70	80	98	113,5	
AC	48,5	60	70	85	100	
AD	44	55	65	80	95	
AE	40	55	65	80	95	
AF	30	40	40	55	55	
AG	117	146	186	220	255	
AH	23	27	30	32	36	
AI	12,5	14,5	17,5	19	23	
AL	19	22,5	24,5	26	30	
AM	7,5	10,5	11,5	13,5	16	
AP	13	15,2	23	30	35,5	
EE	G1/8"	G1/4"	G1/4"	G1/4"	G3/8"	
L1	100	125	150	175	215	
LA	200	250	300	350	430	
RA	M4	M5	M5	M6	M6	
RB	7,5	9,5	9,5	11,5	11,5	
RT	M5	M6	M6	M8	M8	
RV	13,5	16,5	16,5	20,5	20,5	
TA	30	40	40	65	65	
TB	80	110	110	160	160	
TC	23	30	30	40	40	
TD	27	36	47	54	68	
TE	6,5	9,5	9	13	13,5	
Weight	stroke 0	900	1650	2650	4330	8010
g	every 100mm	225	340	490	725	1070

STROKE TOLERANCE: + 2 mm.

Basic version cylinder

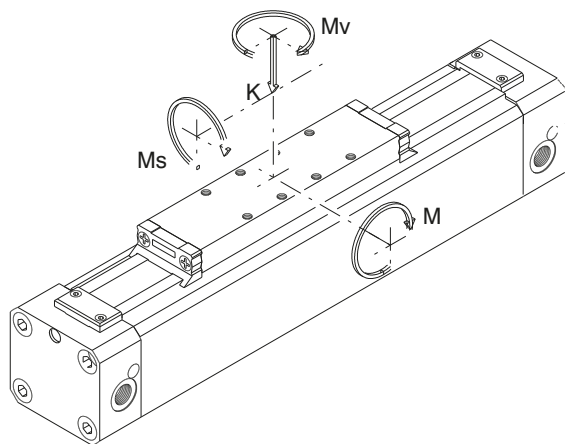

Operating end stroke decelerator diagram

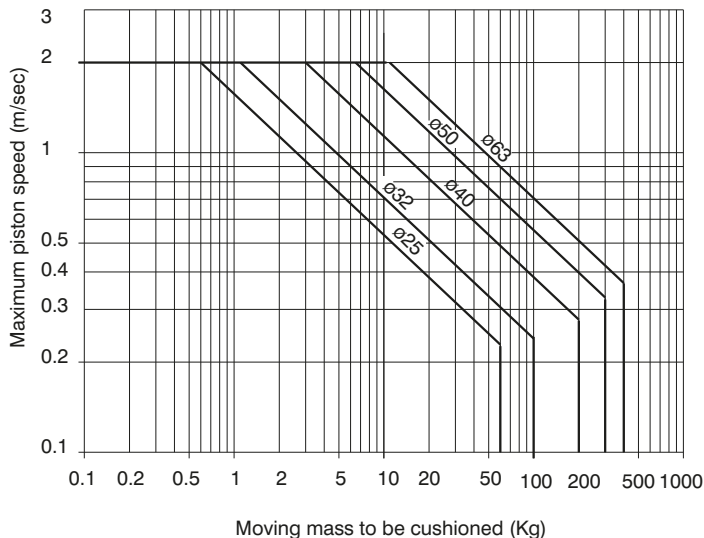

3 PNEUMATIC ACTUATION

Recommended loads and moments in static conditions

CYLINDER BORE	DECELERATING STROKE (mm)	MAX. RECOMMENDED LOAD K (N)	MAX. RECOMMENDED BENDING MOMENT M (Nm)	MAX. RECOMMENDED CROSS MOMENT Ms (Nm)	MAX. RECOMMENDED TWISTING MOMENT Mv (Nm)
25	20	300	15	0.8	3
32	25	450	30	2.5	5
40	31	750	60	4.5	8
50	38	1200	115	7.5	15
63	49	1600	150	8.5	24

Attention: use guided carriage for heavier loads or precise linear movements (MG or MH versions).

All reported data are referred to carriage plane and indicates MAX - values in static conditions. These values should not be exceeded either in dynamic conditions (best speed <1m/sec). Should the cylinder be utilised at its maximum performances, ensure the proper additional absorbers are used.

Calculation of permissible load (Kd) in dynamic conditions  $K_d = K \cdot C_v$

Coefficient of velocity diagram

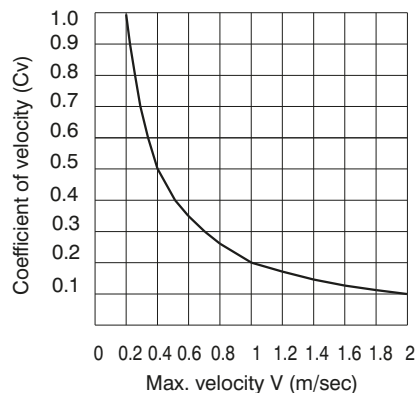

Loads under combined stressing conditions

It is important to take into consideration the following formula when there are a combination of forces with torque:

$$\left[ \left( 2 \times \frac{M_s}{M_{s \max}} \right) + \left( 1.5 \times \frac{M_v}{M_v \max} \right) + \frac{M}{M \max} + \frac{K}{K \max} \right] \times \frac{100}{C_v} \leq 100$$

► **Cylinder with linear control unit (Ø 25, Ø32, Ø40 and Ø50)**

Ordering code  
**1605.Ø.stroke.01.MG**  
(Max. stroke 3mt.)

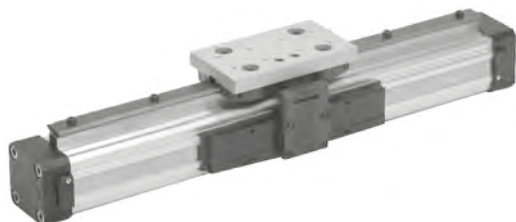

Cylinders Ø 25

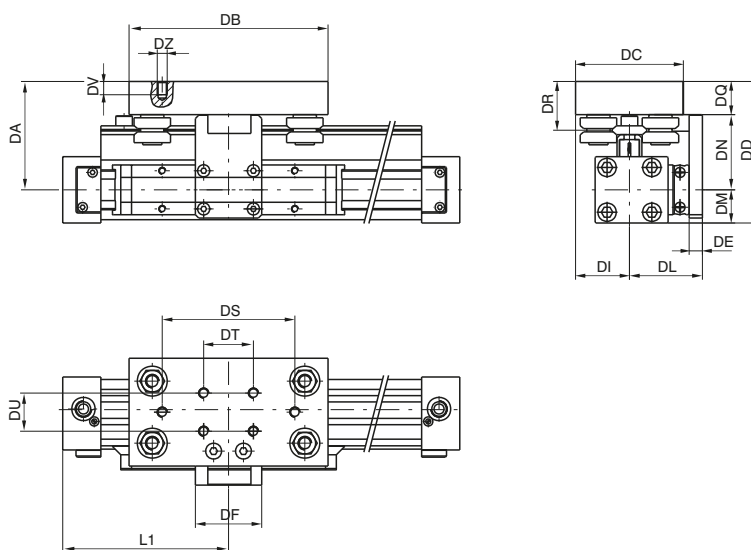

Cylinders Ø 32, Ø 40, Ø 50

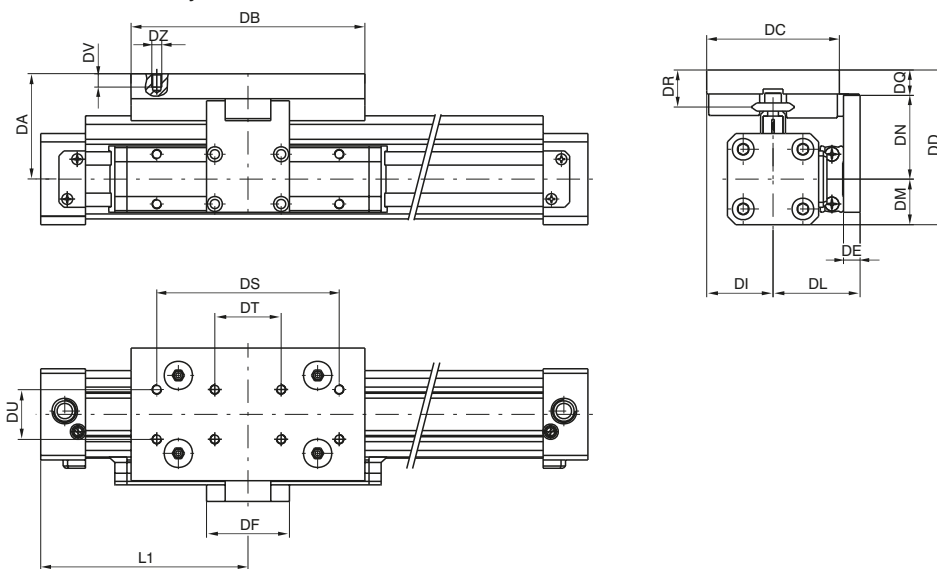

Bore	DA	DB	DC	DD	DE	DF	DI	DL	DM	DN	DQ	DR	DS	DT	DU	DV	DZ	L1	Weight guide	every 100mm
25	65	120	65	85	8	40	32,5	44	20	45,5	19,5	29	80	30	23	8	M6	100	g 850	g 90
32	63	141	80	90,5	10	50	40	52,5	27,5	48,5	14,5	21,5	110	40	30	8	M5	125	g 950	g 90
40	68,5	141	80	101	10	50	40	57,5	32,5	54	14,5	21,5	110	40	30	8	M5	150	g 950	g 90
50	76	141	80	116	12	80	40	70	40	61,5	14,5	21,5	110	40	30	8	M5	175	g 950	g 90

For cylinder weight refer to base version

**Construction characteristics of linear control unit**

Rod	carbon steel with hardness higher than 55-60 HRC
Bearing with shaft	shielded bearing with shaped ring
Carriage plate	anodised aluminium
Cover	acetal resin

Cylinders with linear control unit Ø32, Ø40 and Ø50

Max. suggested loads and moments

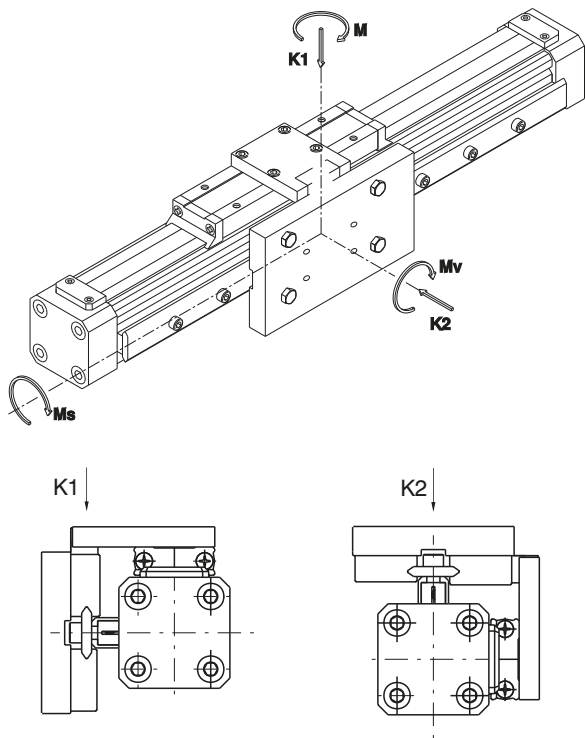

K1 (N)	K2 (N)	M (Nm)	Ms (Nm)	Mv (Nm)
960	960	40	12	40

Max. load (K1 o K2) depending on the distance LC between the supports

K1 ..... K2 .....

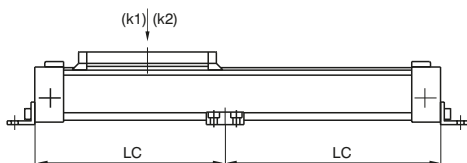
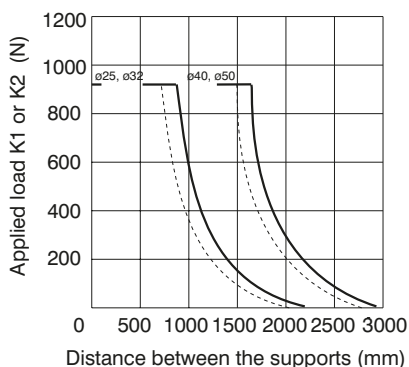

Real load (CE) under combined stressing conditions

It is important to take into consideration the following formula when there are a combination of forces with torque :

$$CE = [K1 + K2 + (24 \times M) + (80 \times Ms) + (24 \times Mv)] \leq 960$$

Nomograph load / life

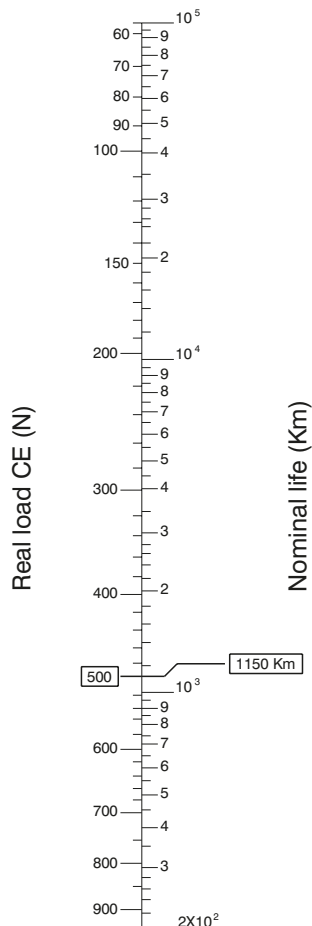

All data refers to a linear control unit properly lubricated with linear speed < di 1.5 m/s

Example to compute the life

Compute the linear control unit life with a load of 100 N applied 50 mm off its axle.

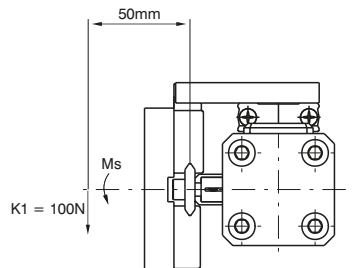

$$Ms = 0,05 \times 100 = 5 \text{ Nm}$$

$$K1 = 100 \text{ N}$$

How to compute the real load using the formula:

$$CE = [K1 + K2 + (24 \times M) + (80 \times Ms) + (24 \times Mv)]$$

$$CE = [100 + 0 + (24 \times 0) + (80 \times 5) + (24 \times 0)] = 500 \text{ N}$$

After having verified that the CE is lower than 960 N we realise that the life is 1150 Km from the nomograph.

► **Cylinder with sliding shoes guide** (Ø 25, Ø 32, Ø 40, Ø 50 and Ø 63)

Ordering code
<b>1605.Ø.stroke.01.MH</b>

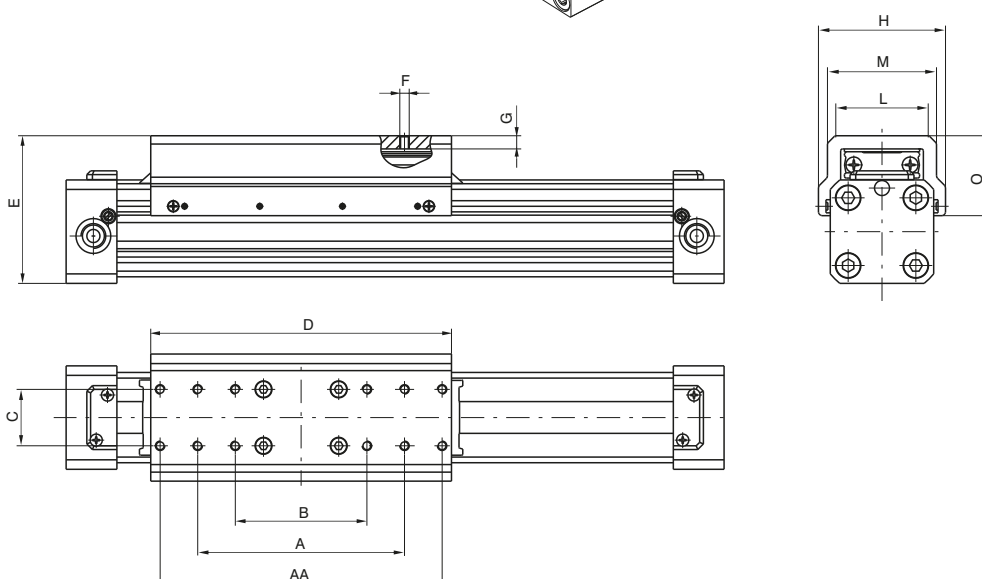
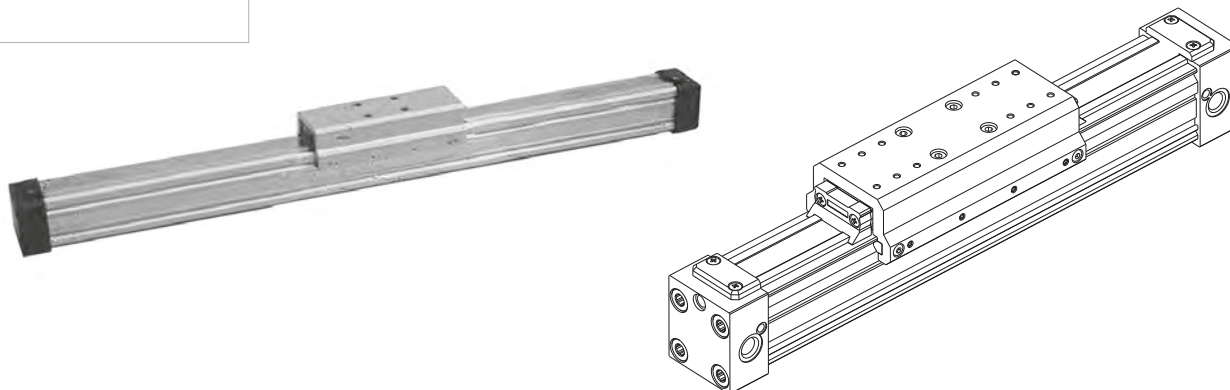

Bore	AA	A	B	C	D	E	F	G	H	L	M	O	Weight g
Ø25	/	80	55	23	130	64 <sup>±1</sup>	M4	6,5	57	36	42	32	g 235
Ø32	/	110	70	30	160	78,5 <sup>±1</sup>	M5	7	68	50	58	42,5	g 445
Ø40	/	110	70	30	202	88,5 <sup>±1</sup>	M5	7	77	52	60	45,5	g 595
Ø50	210	160	110	40	235	114,5 <sup>±1</sup>	M6	14	100	71	83	61,5	g 1453
Ø63	210	160	110	40	270	130 <sup>±1</sup>	M6	14	116	76	90	65,5	g 1810

For cylinders weight refer to base version

► **Complete sliding shoes guide**

Ordering code
<b>1600.Ø.05F</b>

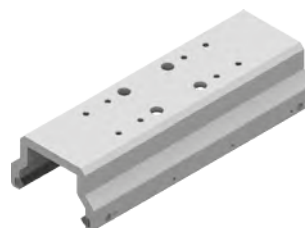

**Construction characteristics of guide**

Sliding shoes guide	reinforced carbon fibre nylon
Mounting plate	extruded anodised aluminium

**Cylinder with sliding shoes guide  $\varnothing 25$ ,  $\varnothing 32$ ,  $\varnothing 40$ ,  $\varnothing 50$  and  $\varnothing 63$**

**Max. suggested loads and moments**

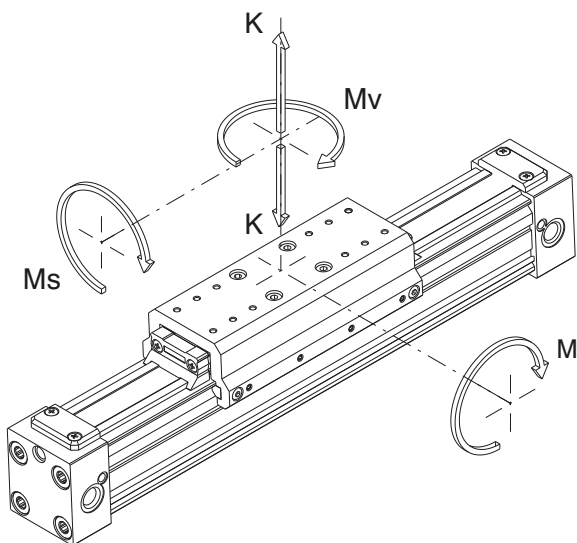

**Recommended loads and moments in static conditions**

CYLINDER BORE	MAX RECOMMENDED LOAD K (N)	MAX RECOMMENDED BENDING MOMENT M (Nm)	MAX RECOMMENDED CROSS MOMENT Ms (Nm)	MAX RECOMMENDED CROSS MOMENT Ms (Nm)
$\varnothing 25$	300	20	1	4
$\varnothing 32$	450	35	3	6
$\varnothing 40$	750	70	5	9
$\varnothing 50$	1200	120	8	16
$\varnothing 63$	1600	155	9	25

► **Sensor brackets codes 1600.\_, SRS.\_, SHS.\_**

Ordering code
<b>1600.A</b>

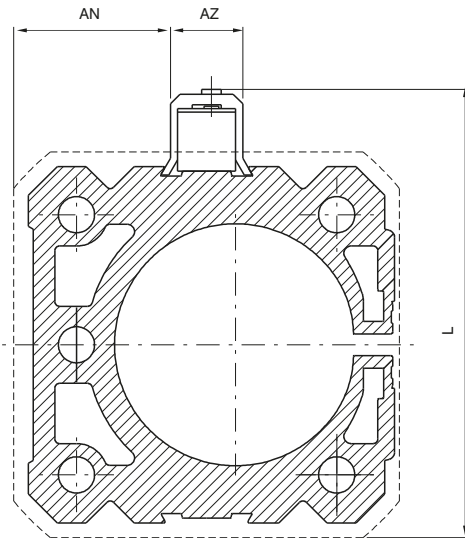

Bore	25	32	40	50	63
AN	12,5	20	25	32,5	40
AZ	15	15	15	15	15
L	55	68	79	94	110
LB	45	58	69	84	100
Weight g	1600.A	3	3	3	3
	1600.B	1	1	1	1

► **Sensor brackets codes 1580.\_, MRS.\_, MHS.\_**

Ordering code
<b>1600.B</b>

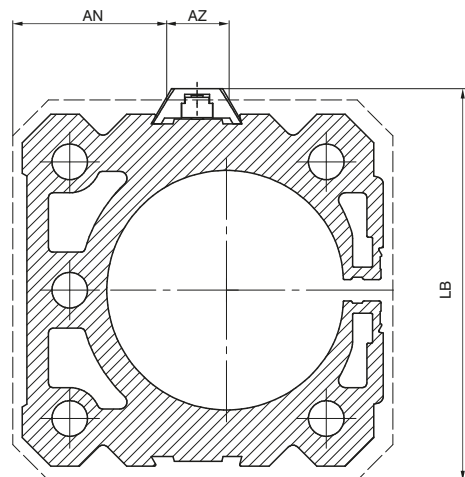

► **Sensors**

For technical characteristics and ordering codes see magnetic sensors section

**Instruction on how to use the sensors properly**

Particular attention must be paid not to exceed the working limits listed in the tables and that the sensor is never connected to the mains without a load connected in series; these are the only measures that if not observed can put the circuits out of order. In the case of direct current ( D.C.) connection polarities must be respected, that is the brown wire to the positive load (+) and the blue to the negative (-). If these are inverted the sensor remains switched, the load connected and the led turned off. However, this would not damage the circuit.

For the "U" type sensors attention must be paid that the length of the cable doesn't exceed 8 metres, with tension above 100 V. In this case a serial resistance is added to reduce the cumulative effects of the line.

As an example 1000 W per 100-130 V e 2000 W per 200-240 V.

Foot

Ordering code  
**1600.Ø.01F** (1 piece)

**Bore**  
25 - 32

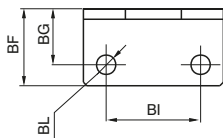
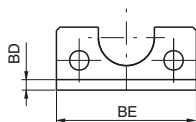
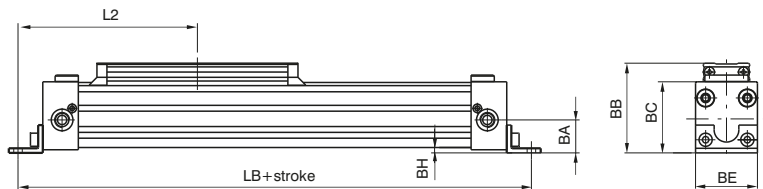

**Bore**  
40 - 50 - 63



Bore	25	32	40	50	63
BA	21,5	28	32,5	41	49
BB	58	72,5	81,5	100	116
BC	46	57,5	66,5	82	97,5
BD	3	3	20	25	30
BE	40	55	65	80	95
BF	22	25	25	25	30
BG	16	18	12,5	12,5	15
BH	3,5	6	4,5	5	5
BI	27	36	30	40	48
BL	5,5	6,6	9	9	11
L2	116	143	162,5	187,5	230
LB	232	286	32,5	375	460
Weight g	30	45	65	110	190

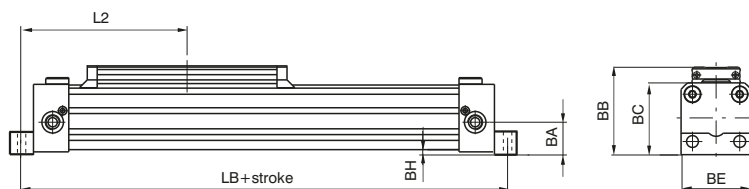
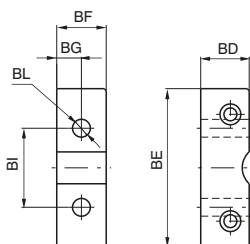

PNEUMATIC ACTUATION



► Intermediate support

Ordering code
<b>1600.Ø.02F</b>

**Bore  
25 - 32**

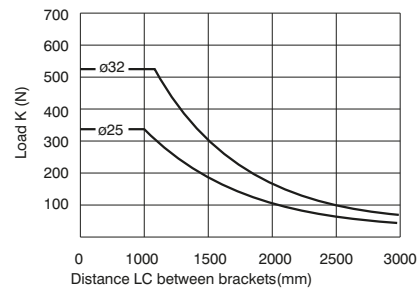
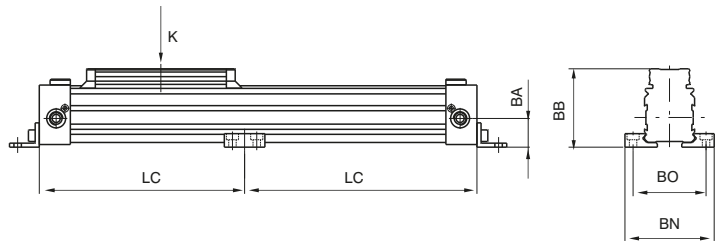
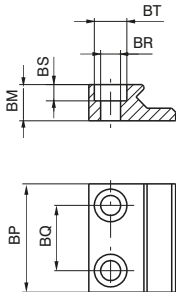
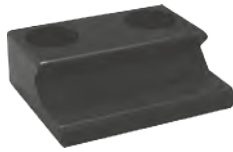

**Bore  
40 - 50 - 63**

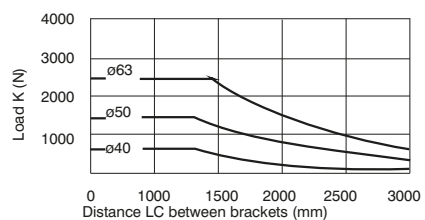
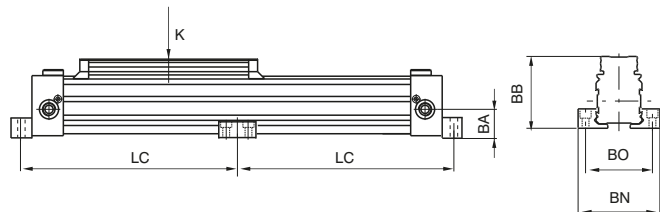
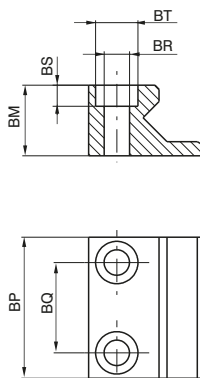
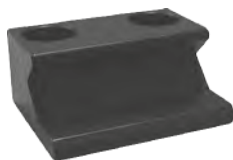

Bore	25	32	40	50	63
BA	21,5	28	32,5	41	49
BB	58	72,5	81,5	100	116
BM	10	18	18	25	30
BN	66	86	96	120	140
BO	54	70	80	100	120
BP	30	40	40	50	50
BQ	18	25	25	32	32
BR	5,5	6,6	6,6	9	9
BS	4,5	5,5	5,5	7,5	7,5
BT	9	11	11	15	15
Weight g	25	80	80	160	215

**Oscillating hinge**

Ordering code

**1600.Ø.03F**

**Bore**  
**25 - 32**

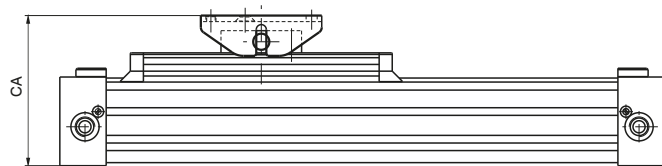
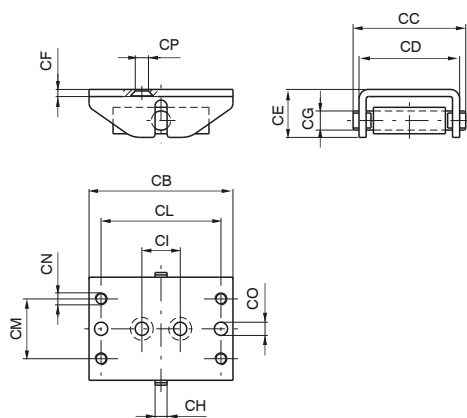

Bore	25	32	40	50	63
CA (±5,5)	76	99,5	108,5	135,5	151
CB	60	100	100	120	120
CC	47	64	64	92	92
CD (±5)	42	56	56	80	80
CE	20	30	30	42	42
CF	3	4	4	6	6
CG	8	12	12	16	16
CH	5	8	8	10	10
CI	16	40	40	65	65
CL	50	80	80	100	100
CM	25	30	30	47	47
CN	M5	M6	M6	M8	M8
CO	5,5	6,5	6,5	9	9
CP	5,5	7	7	-	-
Weight g	130	380	380	990	990

**Bore**  
**40 - 50 - 63**

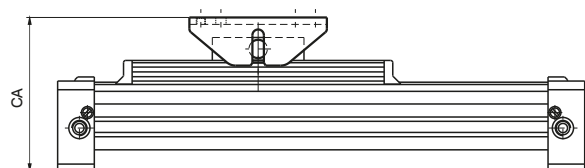
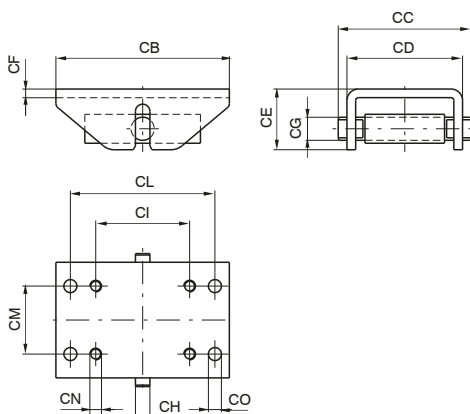

## Series 1600, Mechanically coupled cylinders Ø16

### General

Mechanically coupled cylinder based on the stainless steel strip sealing technology widely used and tested on bigger bore sizes.

**Available versions:** sliding shoe as standard ("MH").

This system ensures high resistance and long life as the carriage which supports the weight is not tied to the piston and therefore the piston only transfers the movement without bearing any force.

**Air connections:** M5 threaded connections.

All air connections on one end cap version available. (side-back-bottom side)

**Mountings:**

- Foot brackets and intermediate supports if needed (depending on the stroke)
- Swivel bracket
- Directly in position via the slot on the end caps- in this conditions the air supply can come directly from the mounting plate.

**Magnetic sensors:** sensors series (1590.... , LRS.... and LHS....) can be used directly in the 2 slots on the barrel.

### Construction characteristics

End cap	Anodised aluminium
Barrel	Anodised aluminium
Bands	Stainless steel
External carriage	Anodised aluminium
Sliding bushes	Special technopolymer
Piston	Acetal resin
Cushion bearings	Aluminium
Piston seals	Special NBR
Other seals	NBR

### Technical characteristics

Fluid	Filtered air. No lubrication needed, if applied it shall be continuous.
Working pressure	1,5 - 8 bar
Working temperature	-5°C - +70°C
Max. speed	1 m/s (normal working conditions)
Max. stroke	2,5 meters
Cushioning length	18 mm

Please follow the suggestions below to ensure a long life for these cylinders:

- use clean and lubricated air
- Please adequately evaluate the load involved and its direction, especially in respect to the moving carriage (also see tables for loads and admitted moments).
- avoid high speeds together with long strokes and heavy loads: this would produce kinetic energy which the cylinder cannot absorb, especially if used as a limit stop (in this case use mechanical stop device)
- evaluate the environmental characteristics of cylinder used (high temperature, hard atmosphere, dust, humidity etc.)

**Please note: air must be dried for applications with lower temperature.**

Use hydraulic oils H class (ISO VG32) for correct continued lubrication.

Our Technical Department will be glad to help.

For applications where a low smooth uniform operations speed is required, you must specify this on your purchase order so that we can use the proper special grease.

### Use and maintenance

This type of cylinder, due to its characteristics, has to be used within certain criteria. Correct use will give long and troublefree operation. Filtered and lubricated compressed air reduce seal wear. Verify that the load will not produce unforeseen stresses. Never combine high speed with heavy load. Always support the long stroke cylinder with intermediate brackets and never exceed the specified working conditions.

If maintenance is required, follow the instructions supplied with the repair kit.

**Basic version (cylinder with sliding shoes bushes)**

Ordering code
<b>1605.16.stroke.01.MH</b>
Possibility of a single feed cylinder head
<b>1605.16.stroke.02.MH</b> left end cap-side connection
<b>1605.16.stroke.03.MH</b> right end cap-side connection
<b>1605.16.stroke.04.MH</b> left end cap-rear connection*
<b>1605.16.stroke.05.MH</b> right end cap-rear connection*
<b>1605.16.stroke.06.MH</b> left end cap-bottom connection
<b>1605.16.stroke.07.MH</b> right end cap-bottom connection

\* in case of mounting with 1600.16.01F bracket use 4mm tube fitting

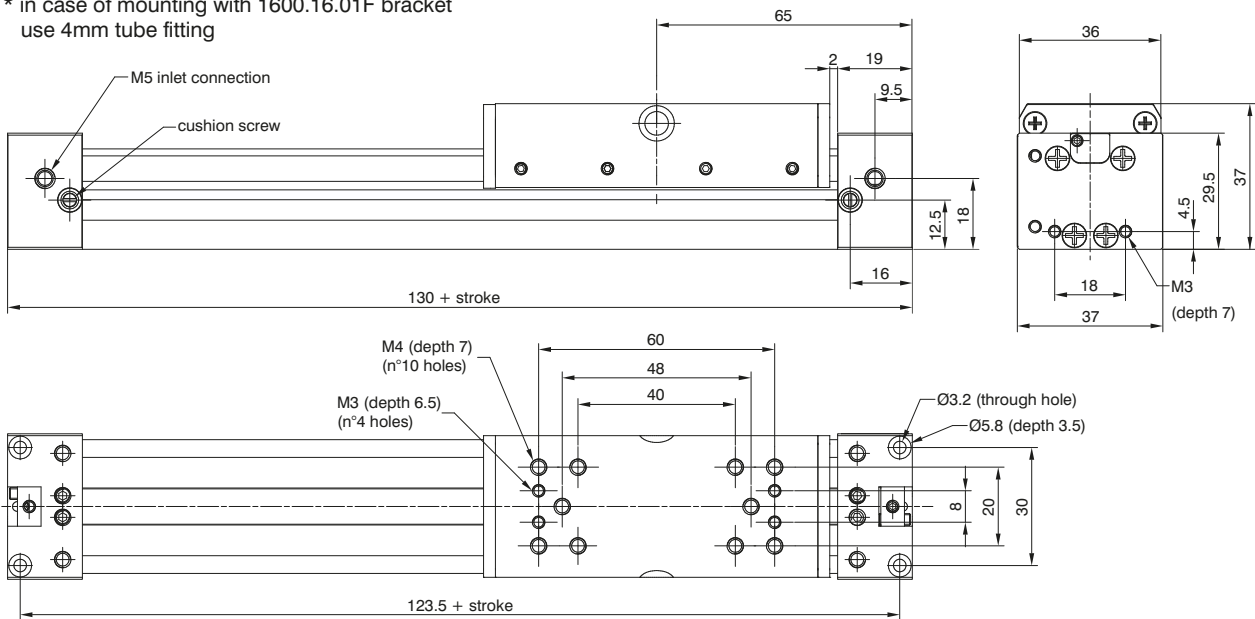
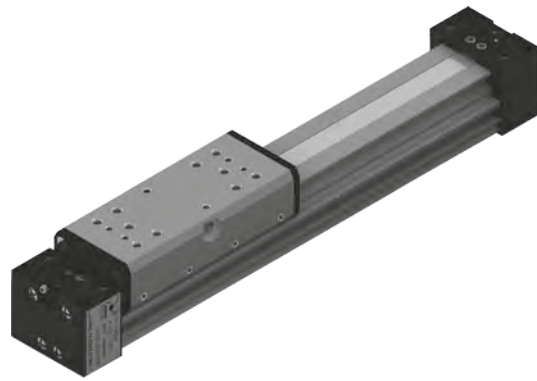

**Possibility of a single feed right or left cylinder head and on 3 different end cap sides**

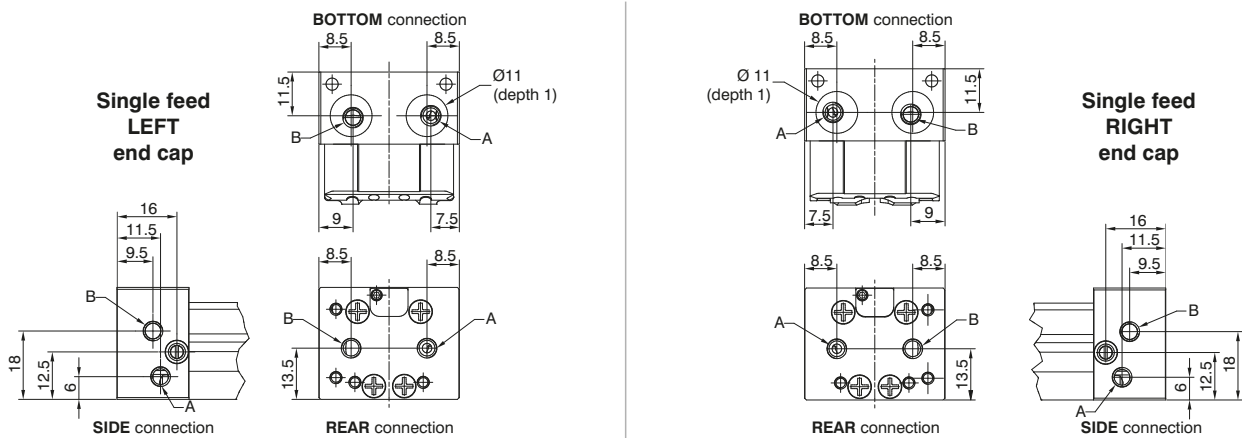

**A = forward stroke connection**  
**B = backwards stroke connection**  
M5 tube Ø4 and Ø6 fittings can be used for air connections.  
In case of use with 1600.16.01F mounting and REAR air connections use a 4mm pipe fitting.

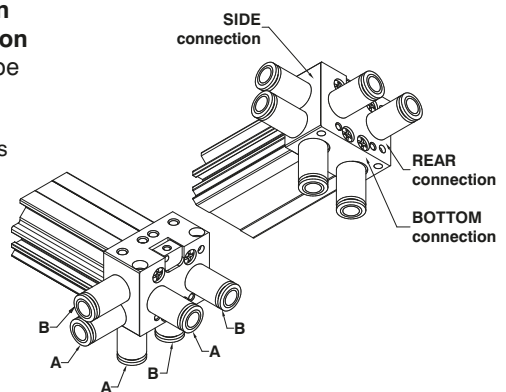
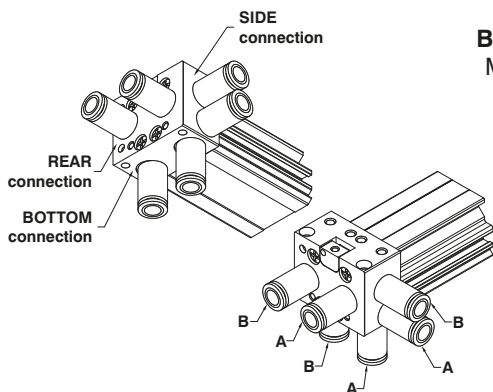

### ▶ Operating end stroke decelerator diagram

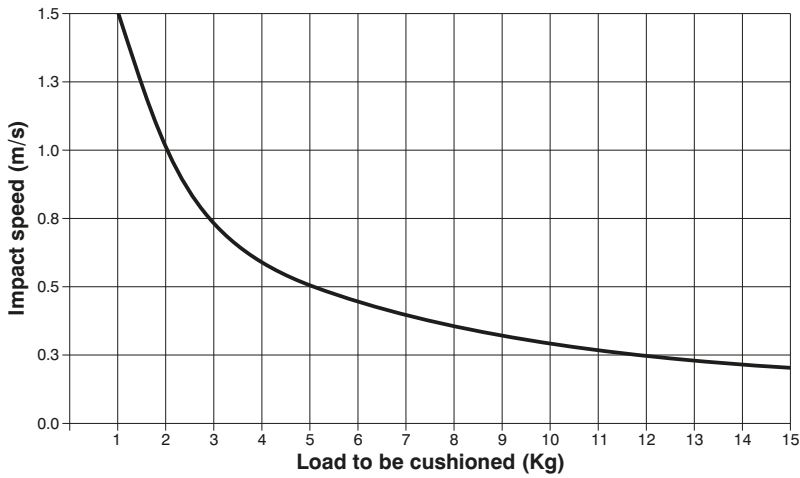

In case of extreme applications close to the maximum allowed values in the graph it is strongly recommended to add external damping systems.

### ▶ Suggested loads and moments

K1	K2	K	M	Ms	Mv
200	250	100	10	2	3
(N)			(Nm)		

Maximum Load and moments allowed  
in static or dynamic conditions  
(max. speed 0,2 m/s)

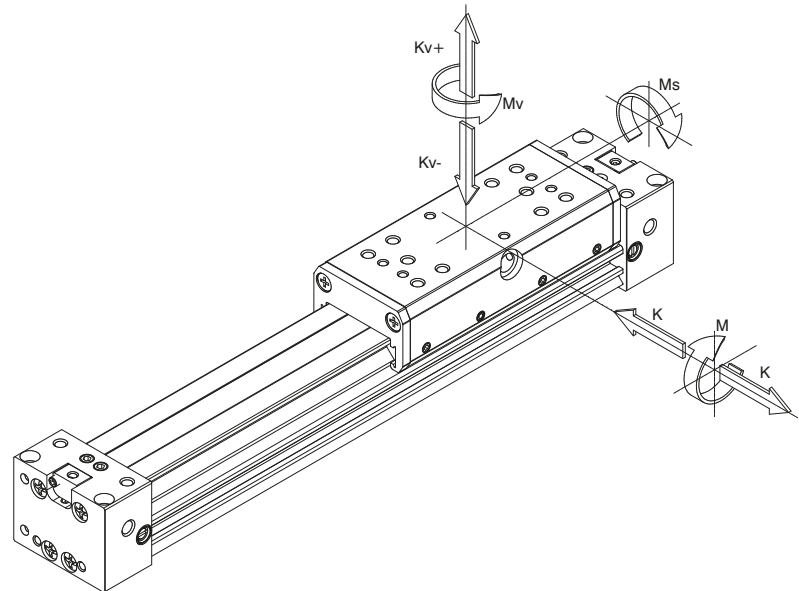

### ▶ Magnetic sensors

Ordering code
<b>1590...</b>
<b>LRS...</b>
<b>LHS...</b>

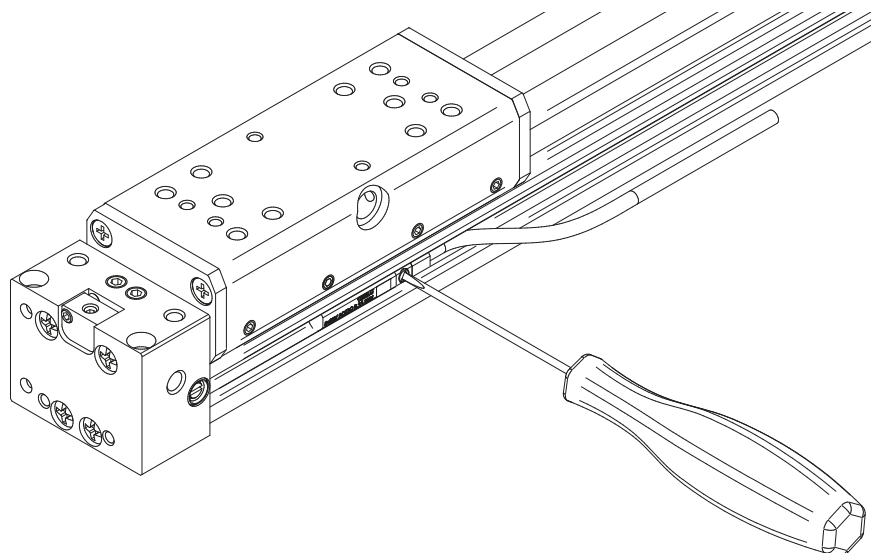

The two side slots allow the direct use of 1590...LRS... and LHS... sensors mounted from the top and positioned via the built in screw.

### Mounting foot brackets

Ordering code

**1600.16.01F**  
(1 piece)

The kit comprises:  
n°1 foot (plated zinc steel)  
n°2 screws (plated zinc steel)

**Attention:** based on the stroke evaluate the need to use also side mounted supports. (see below)

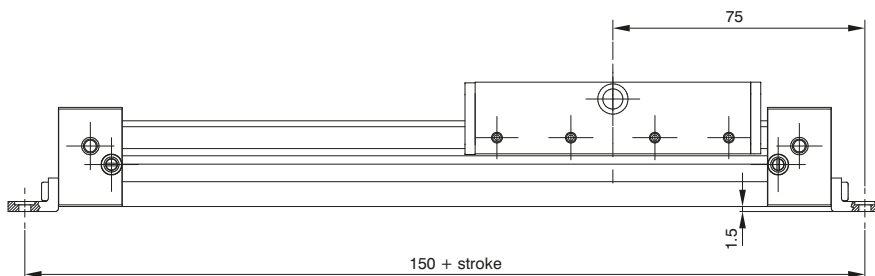
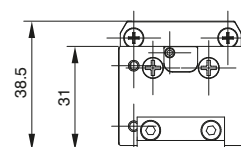
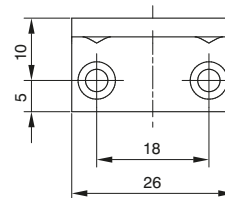
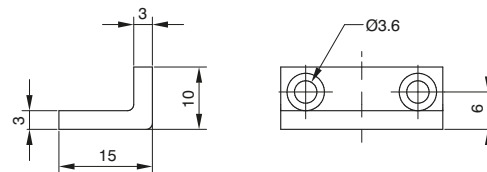
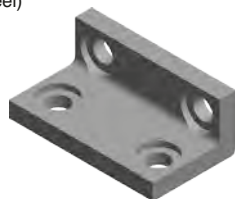

### Intermediate support

Ordering code

**1600.16.02F**  
(1 piece)

The kit comprises:  
n°1 support (aluminium)  
n°2 screws (plated zinc steel)

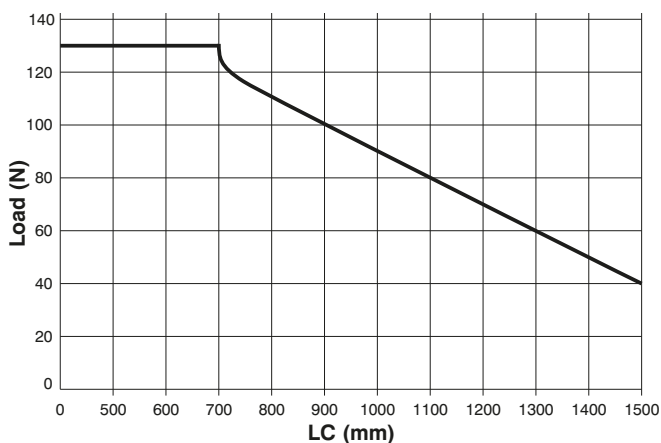
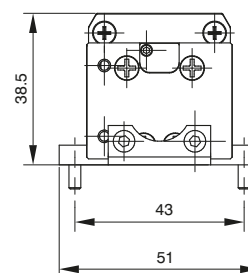
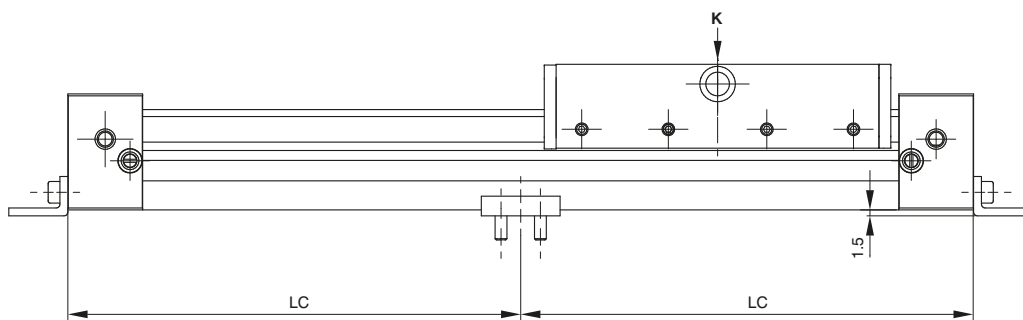
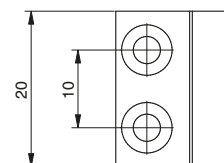
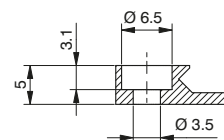
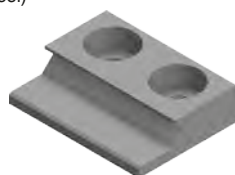

The graph shows the LC limit in conjunction with the applied load K beyond which it is necessary to mount an intermediate side support in order to prevent the barrel from bending.

### Oscillating hinge

Ordering code
<b>1600.16.03F</b> (1 piece)

The kit comprises:  
n°2 pins (plated zinc steel)  
n°2 grub screw (steel)  
n°1 oscillating hinge (plated zinc steel)

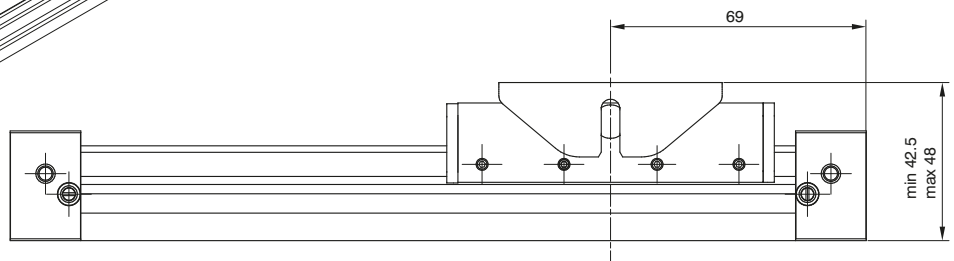
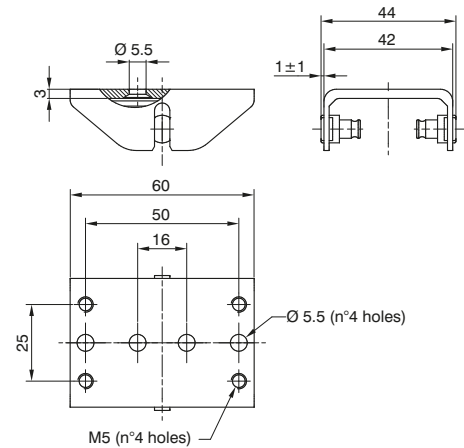
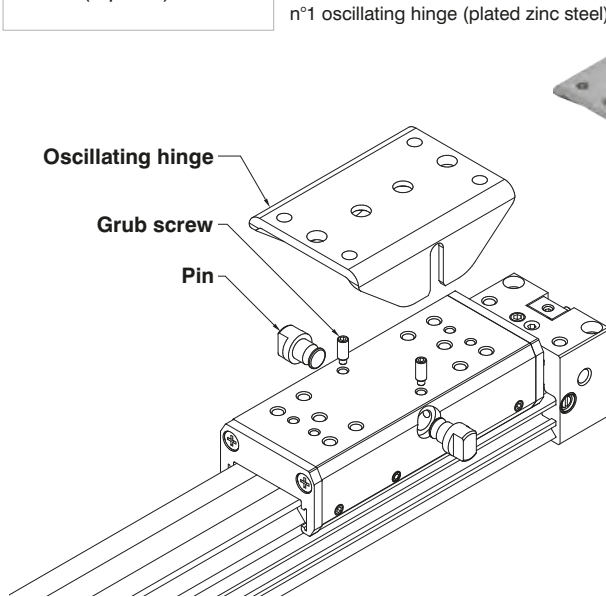

mounting sequence:  
- mount the pin into the dedicated housing  
- tighten the blocking grub screws in the dedicated housing

### Direct mounting without brackets

Ordering code
<b>1600.16.04F</b> (1 piece)

The kit comprises:  
n°4 screws M3x35 (plated zinc steel)  
n°2 O-Rings (NBR)

#### Direct mounting without brackets

Thanks to the mounting holes with counter bores on the end caps it is possible to mount the cylinder directly onto the mounting surface. Having the end caps and barrel flush and in contact with the mounting plate it is not necessary to use any intermediate mounting brackets even in case of long strokes. It is also possible to supply air to the cylinder directly through the mounting plate through the two air connection on the bottom side of the end cap (06.MH and 07.MH) which are machined with counterbores.

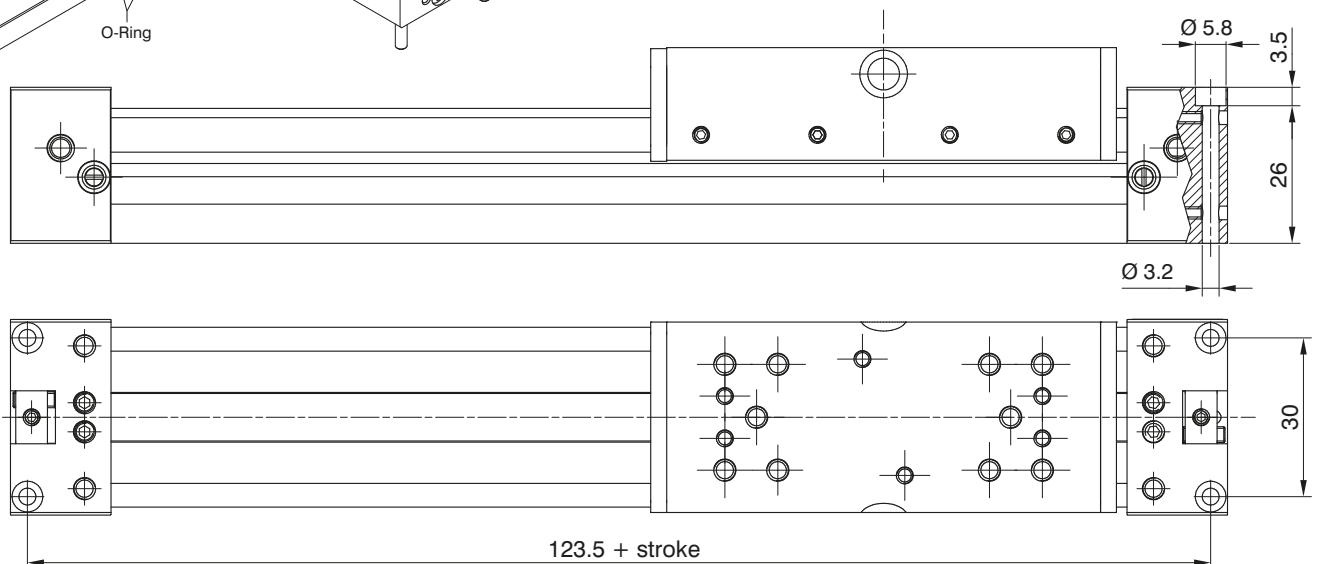
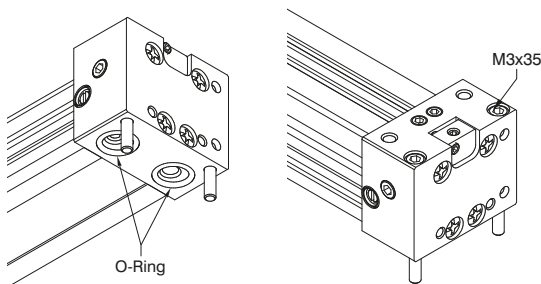

## 1600 Series, Cable driven cylinders

### General

The cable driven cylinders work in a linear translation systems, they are very compact and can be used where a normal cylinder with a rigid rod is too cumbersome. The main characteristic of the cable cylinders is the absence of the rod which, in coming out of the end plate at the end of the stroke, doubles the total overall dimension of the cylinder. In the case of the cable cylinder, the rod is replaced by a metal rilsan-coated cable. It is connected to the piston and coming at the maximum point of stroke never exceeds the overall dimensions of the cylinder.

The cable is connected to the bracket with clamps which serve also to regulate the tension. Because of the construction characteristics of this type of cylinder it must be used with much care. The cable is capable of supporting large stress due to heavy load and high speed. Unfortunately, we cannot give definitive limits of use if not in presence of masses of a few kilograms to be translated (7 - 10 for 16 and 20 - 25 for Ø 25) with speed inversely proportional to the entity of the same load (max 0,5 m/sec). This is done in a way that the load always has a mechanical stop at the end of the stroke. The magnetic piston version lengthens the overall dimensions by 50 mm; the 1200 series microcylinder sensors are used along with the clips of that series.

### Construction characteristics

End caps	anodised black aluminium	Piston seals	NBR 80 Shore (at lip)
Barrel	anodised aluminium	Cable seal	PUR
Piston	aluminium	Bracket	steel
Cable	steel	Cable clamps	brass
Cable covering	Rilsan	Pulleys	aluminium with ball bearing

### Technical characteristics

Filtered air. Max. pressure: 6 bar Min. and max. temperature: -5°C - +70°C Max speed: 0.5 m/sec.  
No lubrication needed, if applied it shall be continuous. **"Attention: Dry air must be used for application below 0°C"**

	A	B	C	D
Standard	111	132	86	124
Magnetic	161	182	136	174



Ordering code
<b>1601.Ø.stroke</b>
<b>1601.Ø.stroke.M</b>
Version with magnetic piston

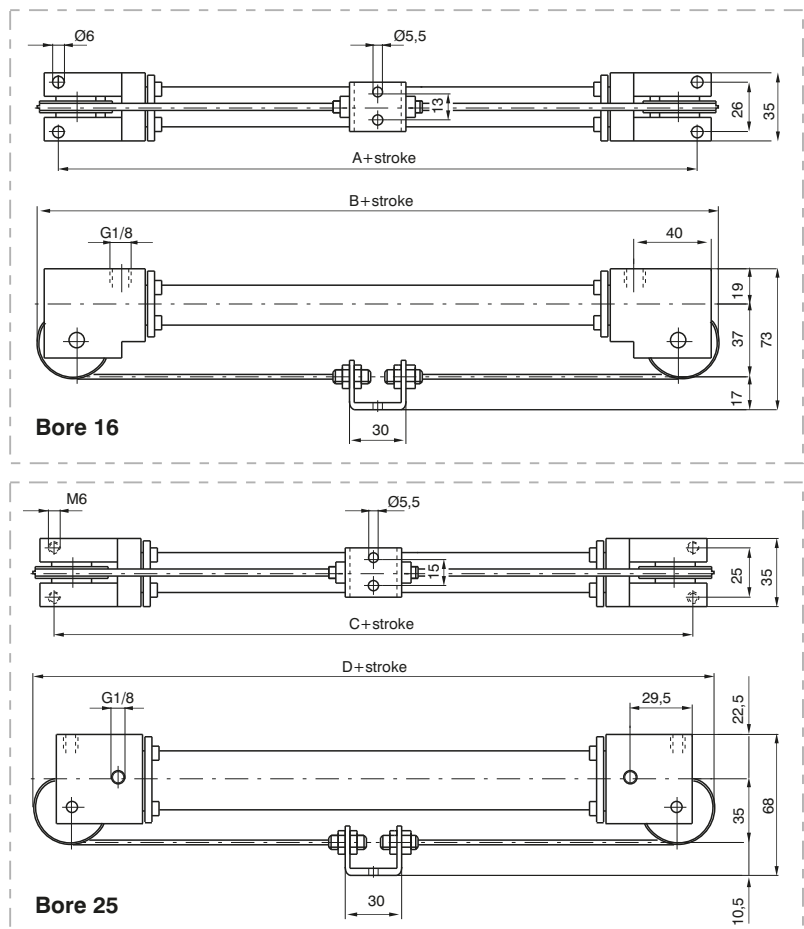

### Maintenance

The cable is obviously the part most subject to breakage. The cylinder can be disassembled for replacement of the cable which is supplied already complete with threaded bushings to be screwed on to the piston. Once the wear of the barrel and seals has been checked, the cylinders can be reassembled by screwing on the end plates. Next, the ends of the cable are attached to the bracket by way of clamps and the tension regulated. The tension is correct when the cable is not cambered.

3 PNEUMATIC ACTUATION





## Series 1330-1331-1332-1333, rotary actuators

### Construction characteristics

End cap	UNI 5079 aluminium alloy casting
Central body	oxidised aluminium
Pinion	18 NiCrMo4 cemented and tempered
Rack	C43
Barrel	anodised aluminium Ra=0.3-0.5
Sliding shoe	acetal resin
Cushion bushings	hardened aluminium
Piston	vulcanized rubber block on steel core with incorporated permanent magnet or without magnet plus rear spacer for non magnetic version
Seals	NBR 80 shore rubber
Cushion adjustment screw	nickel plated steel
Rotating angle adjustment assy	nickel plated brass

### Operational characteristics

Fluid	Filtered air. No lubrication needed, if applied it shall be continuous.
Max. pressure	10 bar
Working temperature	-5°C - +70°C
Standard rotation	90° - 180° - 270° - 360°(+1°)
Rotating angle adjustment assy	±10° (±5° start position, ±5° end position)

Please follow the suggestions below to ensure a long life for these cylinders:

- use clean and lubricated air
- correct alignment during assembly with regard to the applied load so as to avoid radial components or bending the rod.
- avoid high speeds together with long strokes and heavy loads: this would produce kinetic energy which the cylinder cannot absorb, especially if used as a limit stop (in this case use mechanical stop device)
- evaluate the environmental characteristics of cylinder used (high temperature, hard atmosphere, dust, humidity etc.)

**Please note: air must be dried for applications with lower temperature.**

Use hydraulic oils H class (ISO VG32) for correct continued lubrication.

Our Technical Department will be glad to help.

Bore	32	40	50	63	80	100
Torque moments Nm/bar	0,9	1,7	2,9	5,55	13,2	23,8
Axis load max. kg.	8	10	10	12	18	22
Cushioning angle	60°	60°	50°	50°	40°	40°

**Female pinion version**

Ordering code

- 1330.Ø.\*.01**  
magnetic
  - 1331.Ø.\*.01**  
non magnetic
  - 1330.Ø.\*.01R**  
magnetic with  
rotating adjustment  
angle
  - 1331.Ø.\*.01R**  
non magnetic with  
rotating adjustment  
angle
- \* = rotating angle

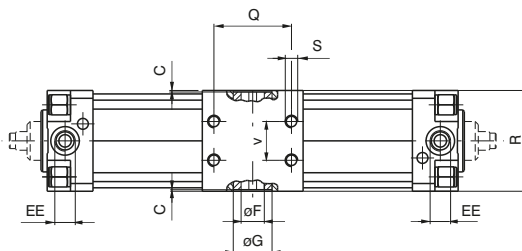
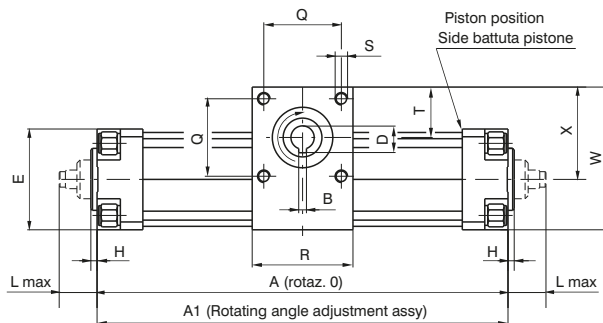

**Male pinion version**

Ordering code

- 1332.Ø.\*.01**  
magnetic
  - 1333.Ø.\*.01**  
non magnetic
  - 1332.Ø.\*.01R**  
magnetic with  
rotating adjustment  
angle
  - 1333.Ø.\*.01R**  
non magnetic with  
rotating adjustment angle
- \* = rotating angle

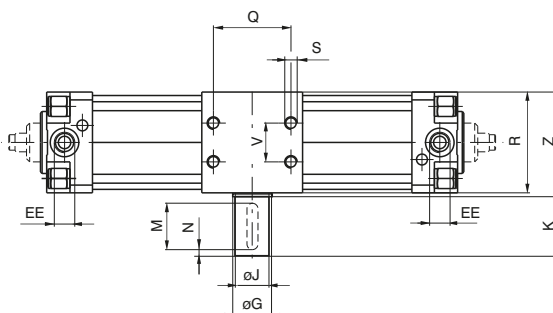
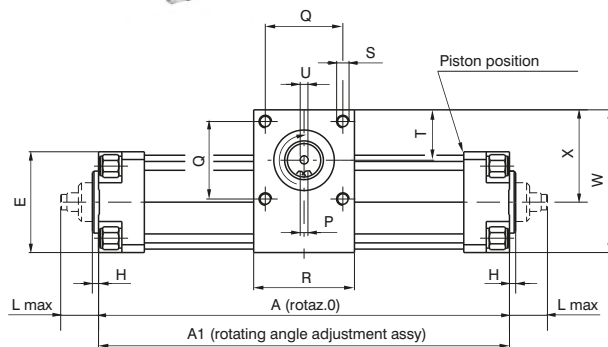

► Dimensions

Bore	32	40	50	63	80	100	
A rot. 0°	171	195	202	233	268	300	
A rot. 90°	218	252	265	308	378	427	
A rot. 180°	265	308	328	382	488	555	
A rot. 270°	312	364	390	457	598	682	
A rot. 360°	359	421	453	531	708	809	
A1 rot. 0°	174	198	206	237	274	307	
A1 rot. 90°	221	255	269	312	384	434	
A1 rot. 180°	268	311	332	386	494	562	
A1 rot. 270°	315	367	394	461	604	689	
A1 rot. 360°	362	424	457	535	714	816	
B	5	5	5	6	6	8	
C	1	1	1	1	1	1	
D	17,3	17,3	17,3	20,8	22,8	28,3	
E	46	52	65	75	95	115	
Ø F (H 7)	15	15	15	18	20	25	
Ø G	25	25	25	30	40	55	
H	4	4	4	4	4	4	
Ø J (h 7)	14	14	22	25	30	35	
K	30	30	40	40	50	50	
L max.	23	23	28,5	28,5	34,5	34,5	
M	25	25	35	35	45	45	
N	2,5	2,5	2,5	2,5	2,5	2,5	
P	5	5	6	8	8	10	
Q	33	40	50	60	80	80	
R	50	60	65	75	100	115	
S	M6	M6	M8	M8	M10	M10	
T	27,5	35	32,5	35,5	50	54,5	
U	M5	M5	M6	M8	M8	M10	
V	18	22	25	35	50	60	
W	71	85	92	105	141	162	
X	48	59	59,5	67,5	93,5	104,5	
Z	51	61	66	76	101	116	
EE	G 1/8"	G 1/4"	G 1/4"	G 3/8"	G 3/8"	G 1/2"	
Piston stroke every 10 ° of rotation	2,61	3,14	3,49	4,14	6,11	7,07	
Female Pinion weight g	rot. 90°	1450	2020	3050	4850	10000	14900
	rot. 180°	1600	2240	3350	5350	11000	16350
	rot. 270°	1750	2460	3650	5850	12000	17800
	rot. 360°	1900	2680	3950	6350	13000	19250
Male Pinion weight g	rot. 90°	1550	2150	3280	5150	10500	15700
	rot. 180°	1700	2370	3580	5650	11500	17150
	rot. 270°	1850	2590	3880	6150	12500	18600
	rot. 360°	2000	2810	4180	6650	13500	20050

► Magnetic sensors

Sensors 1500.\_, RS.\_, HS.\_ series  
Mounting brackets codes 1320.\_ (A, B, C)

**Sensor brackets**

Sensor brackets codes 1500._RS._, HS._	Sensor brackets codes 1595.HAP	Bore	L
Code	Code		
1320.A	1320.ASC	Ø32	60
		Ø40	65
1320.B	1320.BSC	Ø50	77
		Ø63	87
1320.C	1320.CSC	Ø80	105
		Ø100	125
1320.D	1320.DSC	Ø125	145
1320.E	1320.ESC	Ø160	184
1320.F	1320.FSC	Ø200	222

Sensor brackets codes 1580._, MRS._, MHS._		
Code	Bore	L1
1320.AS	Ø32	48
	Ø40	54
1320.BS	Ø50	66
	Ø63	76
1320.CS	Ø80	96
	Ø100	112
1320.DSC	Ø125	145
1320.ESC	Ø160	184
1320.FSC	Ø200	222

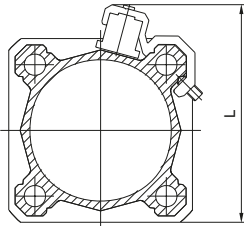

Sensors 1500.\_RS.\_, HS.\_

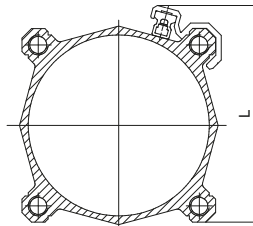

Sensors 1595.HAP

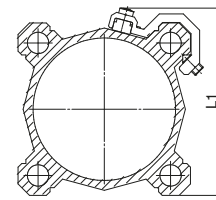

Sensors 1580.\_, MRS.\_, MHS.\_

**Sensors for microbore cylinders:** for technical characteristics and ordering codes see "Magnetic sensors" section

**Solenoid valves supports**

This accessory permits to mount a valve or an electrovalve on a side of the cylinder. The plate can be fitted on the cylinder profiled barrel, and, on it, can be mounted either a threaded distributor or a base on which can be mounted an ISO distributor. Once installed the connections must be done with fittings and pipes. All of the threaded holes on the support plate are dedicated to different valves series as per attached drawing.

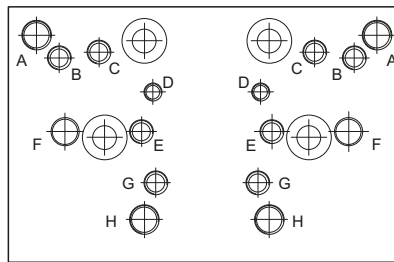

Fixing holes for valves series:

- A = 414/2
- B = 824
- C = 828, T488, 488, 484
- D = 2400
- E = 2600
- F = Bases for ISO distributors
- G = 858/2
- H = T424

Ordering code

- 1320.15 (Ø32 - Ø40)
- 1320.16 (Ø50 - Ø63)
- 1320.17 (Ø80 - Ø100)
- 1320.18 (Ø125)
- 1320.19 (Ø160)
- 1320.20 (Ø200)

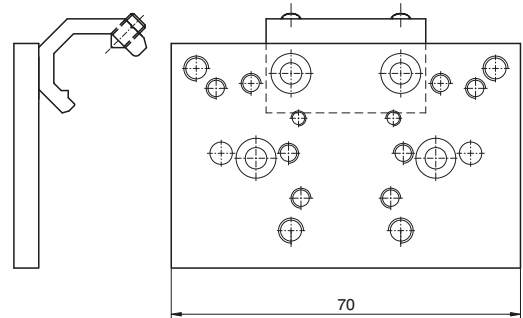

**Bases for ISO solenoid valves**

Ordering code

1320.21	bases for ISO 1 solenoid valves
1320.22	bases for ISO 2 solenoid valves

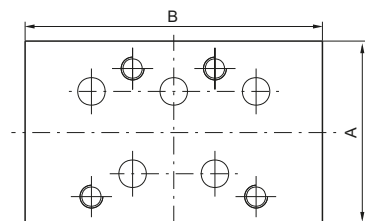

Dimensions

		A	B	C	D
1320.21	bases for ISO 1 solenoid valves	40	75	15	G 1/8"
1320.22	bases for ISO 2 solenoid valves	50	95	20	G 1/4"

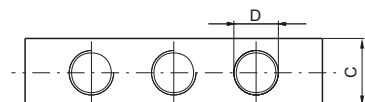



## Series 6400 - Rotary actuators

---

### General

These rotary actuators convert linear motion of a piston into a rotary motion via a rack and pinion device, using a single pinion-rack system for the 6411 version and a double system on 6400 versions. The 6410 series actuators have fixed stops at 90 and 180 degrees; while on the 6400 series, rotation can be adjusted between 0 and 190 degrees using variable stops that can also be substituted with hydraulic stoppers (shock absorbers). These devices are equipped with a rotating table upon which the load is fixed.

► **Double rack rotary actuators with turn table**



**Ordering code**

**6400.** . . .

- A** = Standard
- R** = Cushioning (shock absorber)
- 10** (piston  $\varnothing 15$ )
- 30** (piston  $\varnothing 20$ )
- 50** (piston  $\varnothing 25$ )
- 100** (piston  $\varnothing 32$ )
- 200** (piston  $\varnothing 40$ )

**Construction characteristics**

Body	anodised aluminium
End cap	anodised aluminium
Piston seal	NBR rubber
Pinion	steel
Rack	steel
Turn table	anodised aluminium
Cushioning	elastic bumper (hydraulic damper available on request)

**Operational characteristics**

Fluid	Filtered air. No lubrication needed, if applied it shall be continuous.)
Max. pressure	10 bar (for type 100 and 200, 6 bar)
Working temperature	-5°C - +70°C
Rotation angle range	0 - 190°
Max. rotation	190°
Rotation speed	s/90° (see rotation time table)

Overall dimensions

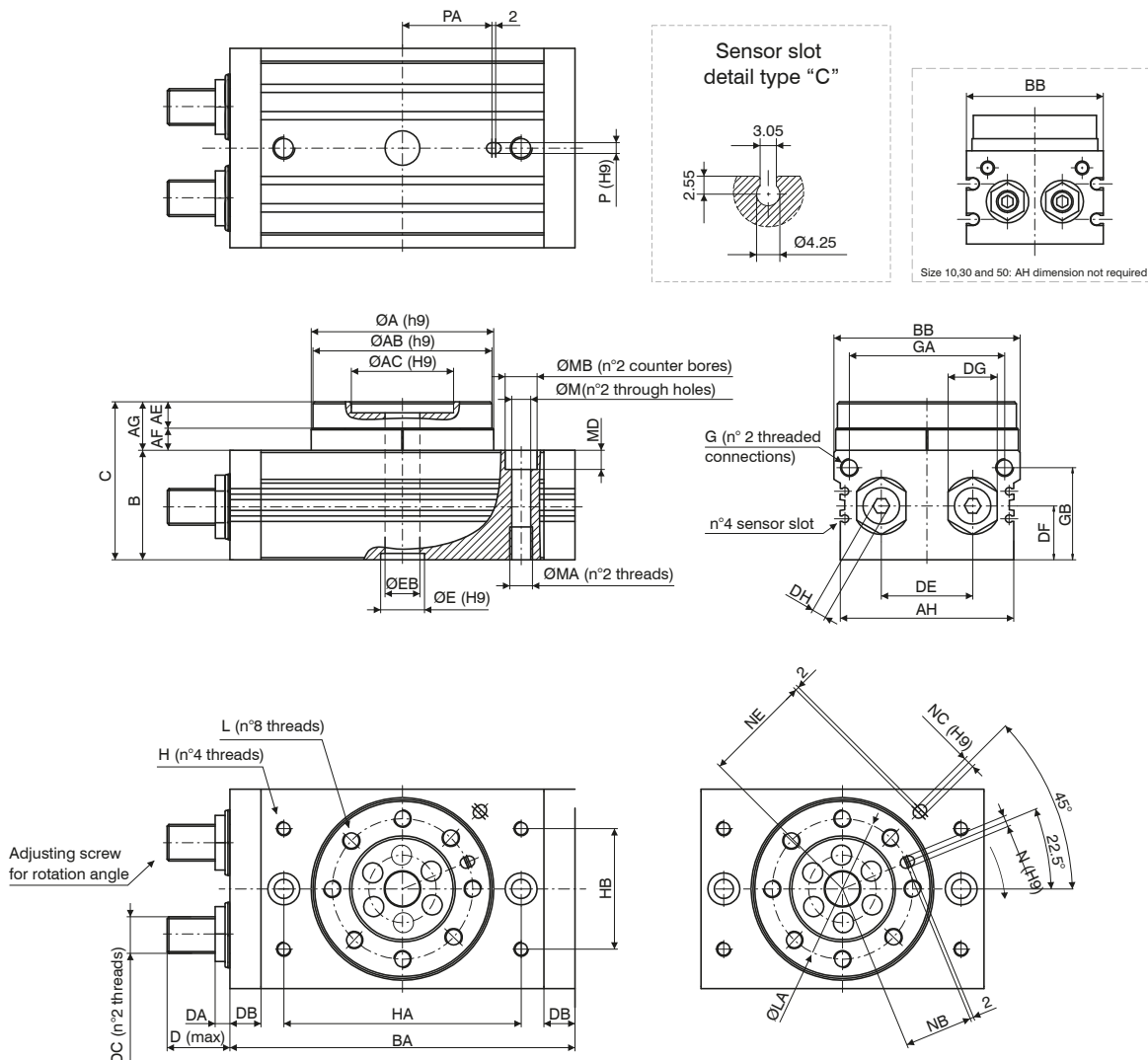

Size	10	30	50	100	200
Ø piston	Ø15	Ø21	Ø25	Ø32	Ø40
ØA <sup>h9</sup>	46	67	77	100	118
ØAB <sup>h9</sup>	45	65	75	98	116
ØAC <sup>H9</sup>	20	32	35	56	64
Useful depth	4	4,5	5	6	9
AE	8	10	12	14,5	16,5
AF	5	7	8	12,5	15,5
AG	13	17	20	27	32
AH	/	/	/	95	114
B <sup>+0,5/0</sup>	34	40	46	59	74
BA	92	127	152	189	240
BB <sup>+0,5/0</sup>	50	70	80	102	120
C <sup>+0,5/0</sup>	47	57	66	86	106
D	17,7	25	31,4	34,3	40,2
DA	8,6	10,6	14	8	20
DB	9,5	12	15,5	17	24
DC	M8x1	M10x1	M14x1,5	M20x1,5	M27x1,5
DE	20	29	38	50	60
DF	15,5	18,5	22	29,5	36,5
DG	12	14	19	27	36
DH	4	5	6	8	10
ØE <sup>H9</sup>	15	22	26	24	32
Useful depth	3	3	3	3,5	5,5
ØEB	5	9	10	19	24
G	M5x0,8	G1/8	G1/8	G1/8	G1/8

Size	10	30	50	100	200
Ø piston	Ø15	Ø21	Ø25	Ø32	Ø40
GA	34,5	50	63	85	103
GB	27,8	32	37,5	50,5	65,5
H	M5x0,8	M6x1	M8x1,25	M8x1,25	M12x1,75
Useful depth	8	8	8	10	13
HA	60	84	100	130	150
HB	27	37	50	66	80
L	M5x0,8	M6x1	M8x1,25	M10x1,5	M12x1,75
Useful depth	8	10	12	14,5	16,5
LA	32	48	55	77	90
M	6,8	8,6	10,5	10,4	14,2
MA	M8x1,25	M10x1,5	M12x1,75	M12x1,75	M16x2
Useful depth	12	15	18	18	25
MB	11	14	18	17,5	20
MD	6,5	8,5	10,5	10,5	12,5
N <sup>H9</sup>	3	4	5	6	8
Useful depth	3,5	4,5	5,5	6,5	8,5
NB	15	23	26,5	37,5	44
NC <sup>H9</sup>	/	/	/	6	8
Useful depth	/	/	/	4,5	4,5
NE	/	/	/	59	69
P <sup>H9</sup>	/	/	/	6	8
Useful depth	/	/	/	4,5	6,5
PA	/	/	/	49	54
Weight (g)	530	1230	2080	4100	7650

**Permissible Loads**

		Size				
		10	30	50	100	200
Radial Load (N)		80	200	320	400	550
Axial Load (N)	Fc	80	370	450	710	1000
	Ft	75	200	300	500	750
Torque Moment (Nm)		2,5	5,5	9,5	18	25

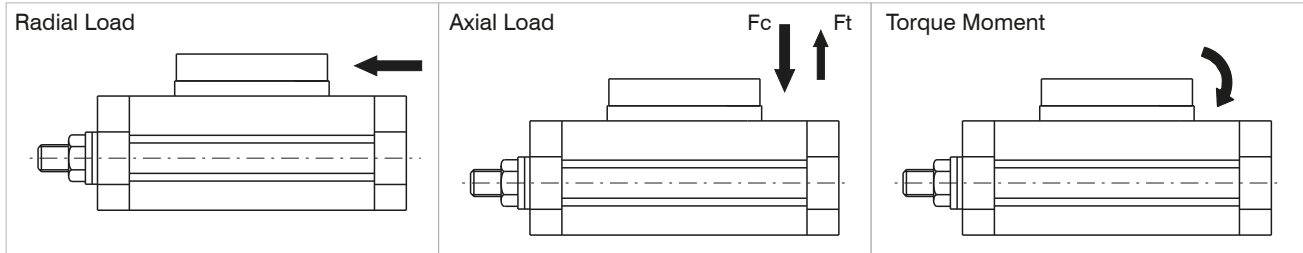

**Torque Diagrams**

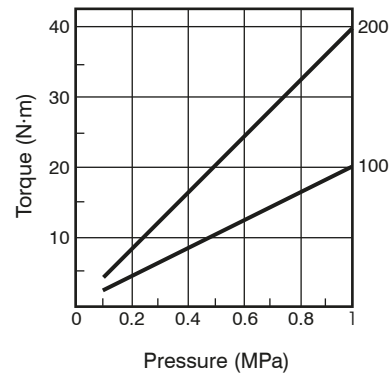
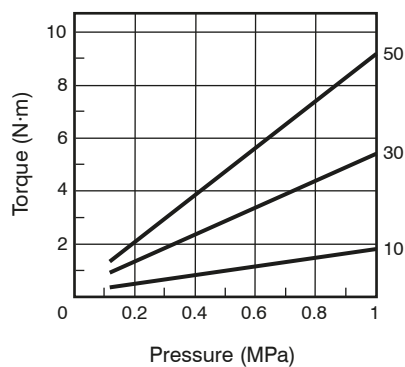

**Rotation time (sec./90°)**

Dimension	With adjusting screw	With hidraulic decelerator
10 - 30 - 50	0.2 - 1	0.2 - 0,7
100	0.2 - 2	0.2 - 1
200	0.2 - 2.5	0.2 - 1

**Kinetic energy**

Dimension	With adjusting screw	With hidraulic decelerator
10	0.006	Please apply to our tech-dpt for info (as general rule expressed valves can be multiplied by 3)
30	0.045	
50	0.08	
100	0.30	
200	0.52	



► Single rack rotary actuators



Ordering code

6411.Ø.  
 — 50 — 90 = rotation 90°  
 — 63 — 180 = rotation 180°  
 — 80  
 — 100

Construction characteristics

Body	anodised aluminium
Piston	aluminium
End cap	anodised aluminium
Piston seal	NBR rubber
Pinion	steel
Rack	steel

Operational characteristics

Fluid	Filtered air. No lubrication needed, if applied it shall be continuous.
Max. pressure	10 bar
Working temperature	-5°C - +70°C
Rotation tolerance	0° - +4°

Overall dimensions Ø50 and Ø63

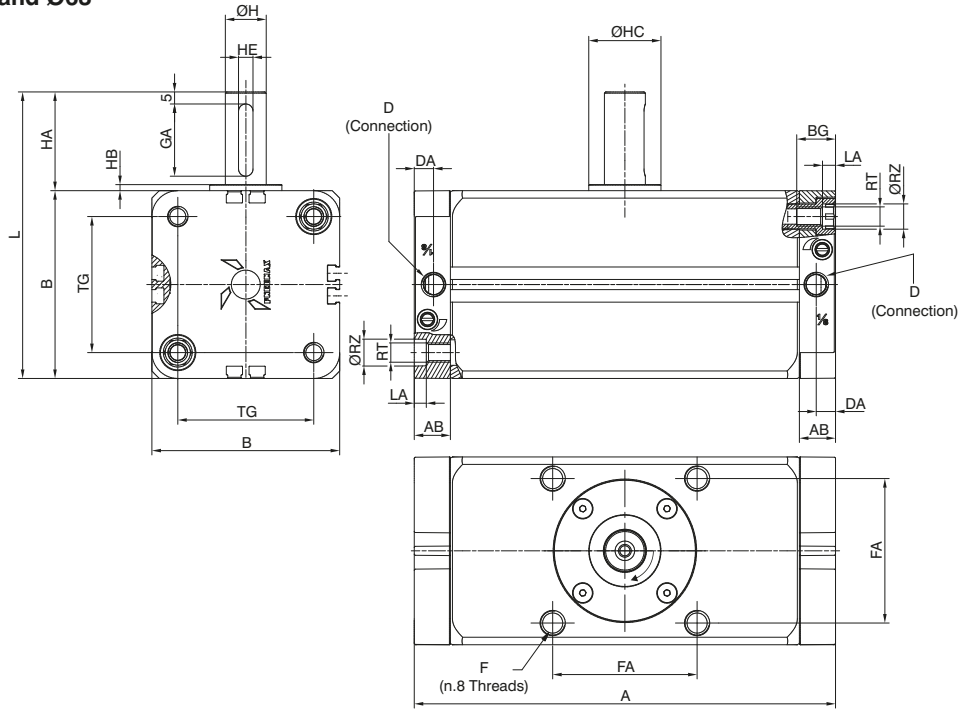

Overall dimensions Ø80 and Ø100

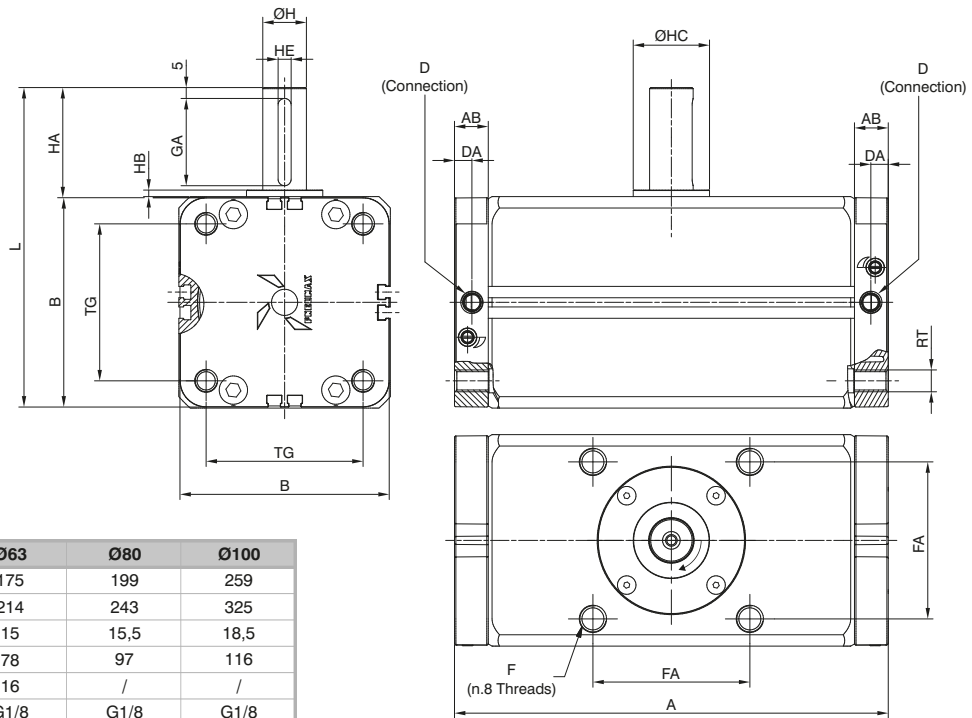

Bore		Ø50	Ø63	Ø80	Ø100
A	90°	156	175	199	259
	180°	189	214	243	325
AB		15	15	15,5	18,5
B		66	78	97	116
BG		16	16	/	/
D		G1/8	G1/8	G1/8	G1/8
DA		8	8	8	8
F		M8x1,25	M10x1,5	M12x1,75	M12x1,75
	Useful depth	12	15	15	18
FA		48	60	72	85
GA		25	30	40	45
H		15	17	20	25
HA		36	41	50	60
HB		2,5	2,5	3	4
HC		25	30	35	39,5
HE <sup>HS</sup>		5	6	6	8
L		102	119	147	176
LA		5	5	/	/
RT		M8	M8	M10	M10
RZ		10,5	10,5	/	/
TG		46,5	56,5	72	89
Weight (g <sup>r</sup> )	90°	1575	2451	4162	6989
	180°	1815	2823	4774	8329

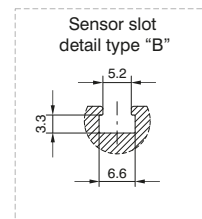

Usable sensors code  
1590.  
LRS.  
LHS.

**Allowable Loads**

	Bore			
	Ø50	Ø63	Ø80	Ø100
Radial load (N)	200	300	400	600
Axial Load in compression (N)	500	600	900	1000
Tensile Axial Load (N)	200			↑

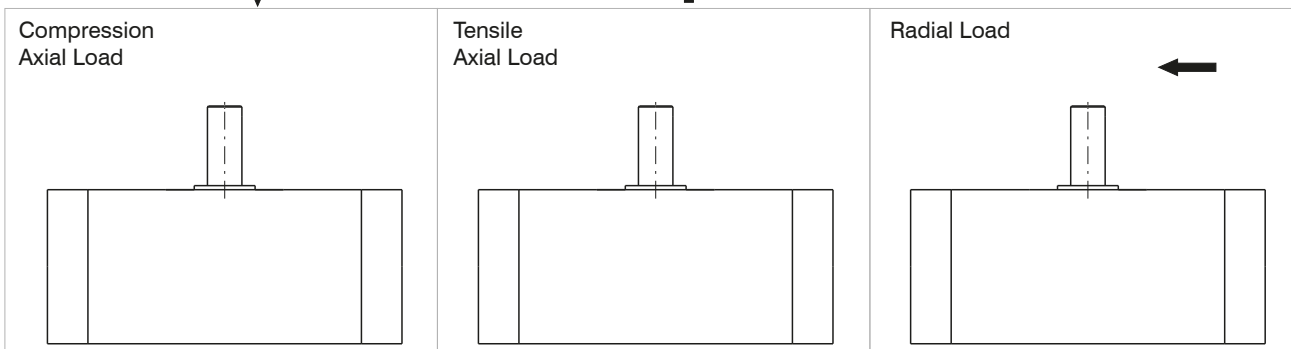

**Torque Diagrams**

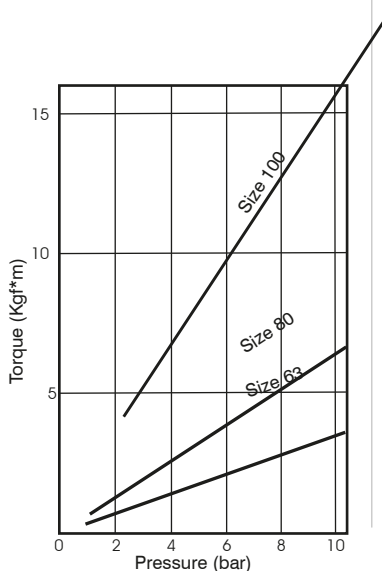
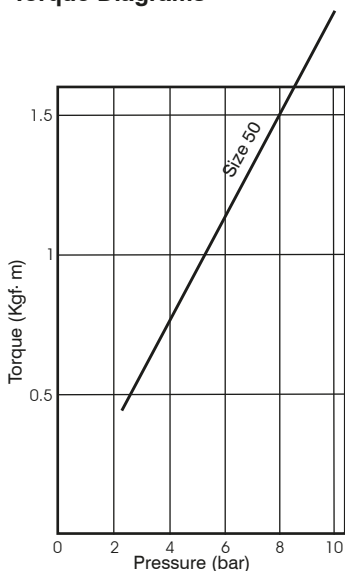

**Max Kinetic energy (Kg·cm)**  
Kinetic energy (cushioning angle 35°)

Bore			
Ø50	Ø63	Ø80	Ø100
10	15	20	30

**Rotation time according to inertial moments**

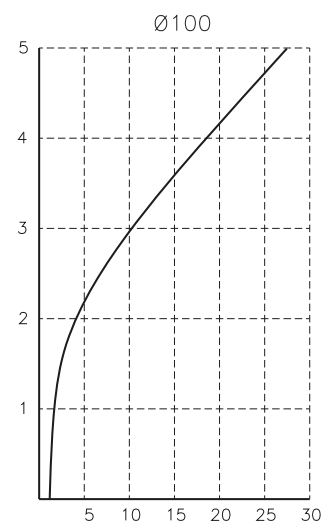
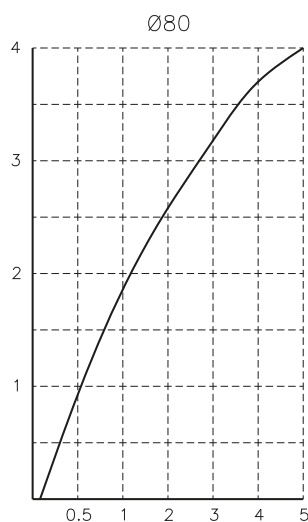
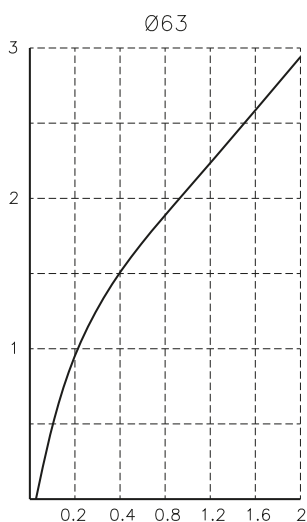
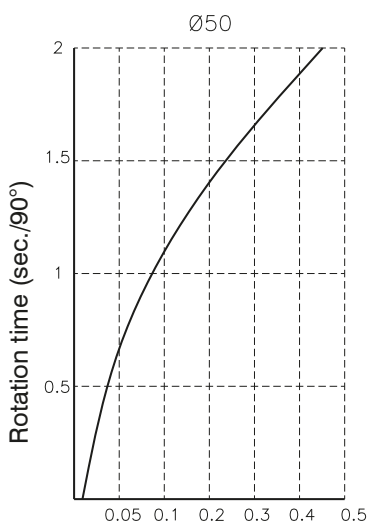

Inertial moments (Kg·cm·sec<sup>2</sup>)



► **Foot (MS1)**

Ordering code

**1540.Ø.05/1F**

The kit comprises:  
n°1 foot (plated zinc steel)  
n°2 screws (plated zinc steel)

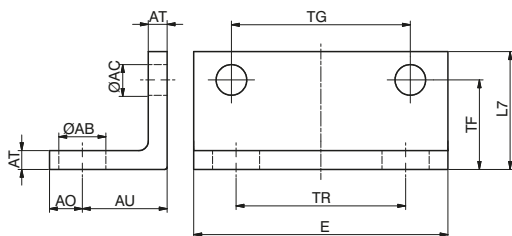
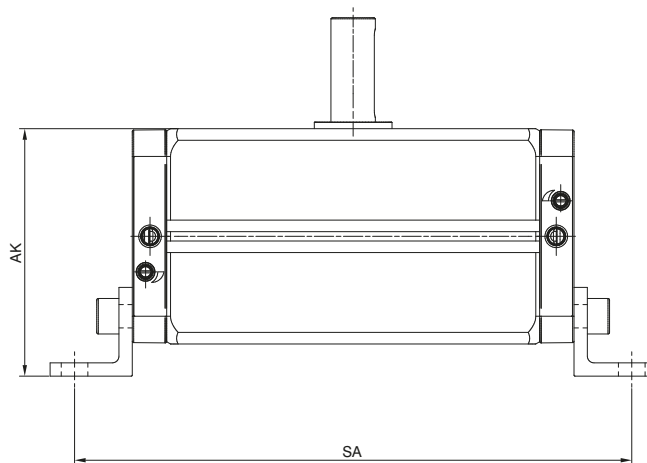

Bore	Ø50	Ø63	Ø80	Ø100
<b>AK</b>	78	89	111,5	132
<b>SA</b>	90°	198	217	251
	180°	231	256	295

► Vane type rotary actuators



**General**

The vane type rotary actuators, 6420 series is designed to operate at 90-180 or 270 deg. In a contained space. Dimensionally are more compact than other types of rotary actuators.

The range includes bore sizes from 10 to 100 in 4 configurations:

- basic.
- with rotary angle adjustment mechanism.
- with sensing support.
- with rotary angle adjustment mechanism and sensing support.

The bodies are in aluminium, the shafts in chrome plated steel and the seals in NBR.

The sensing support kit enables for the sensors to be positioned in any position.

The rotary angle adjustment mechanism enables the adjustment of the complete rotation on bore sizes 10 to 40 while on the others sizes carries as standard hydraulic dampers which enable the adjustment only of the last part of the rotation.

The units can be fixed using the thread on the body or the through holes on the body.

On bore sizes 50 to 100 the shaft runs into ball bearings which ensure high resistance. o rotante è guidato su cuscinetti a sfere che assorbono i carichi radiali e assiali, garantendo durata e affidabilità. assiali, garantendo durata e affidabilità.

**Ordering code**

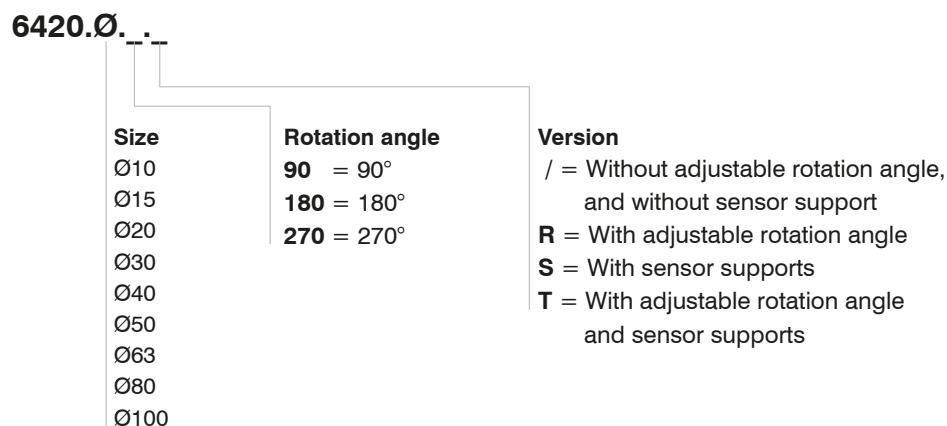

**Construction characteristics**

Body	anodised aluminium
Rod	steel
Seals	NBR
Vane	vulcanized NBR rubber on steel core
Cushoning	elastic bumper; hydraulic dampers from size Ø50 - Ø100 versions R or T

**Operational characteristics**

Fluid	Filtered air. No lubrication needed, if applied it shall be continuous.
Working pressure	1,5 - 7 bar
Temperature	0°C - 50°C
Rotation range	90° - 180° - 270°
Max. allowed leak	Ø10 - Ø40 = 0,3 NI/min / Ø50 - Ø100 = 0,5 NI/min

Overall dimensions Ø10 - Ø40

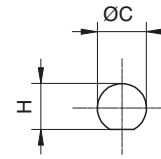
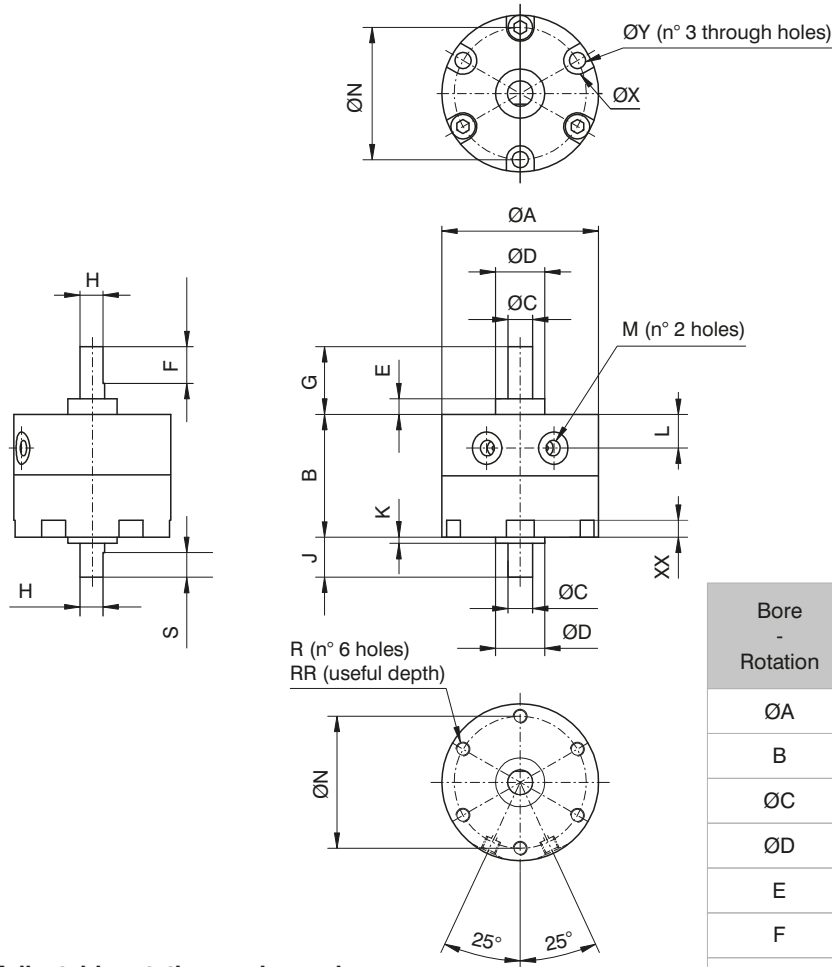

- Ø10 - Ø30 long shaft  
- Ø10 - Ø40 short shaft

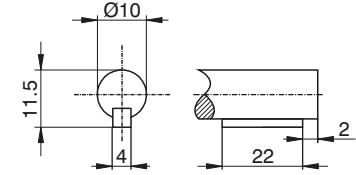

- Ø40 long shaft

Adjustable rotation angle version

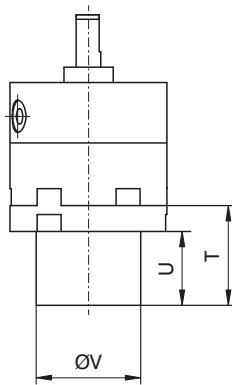

With sensor support version

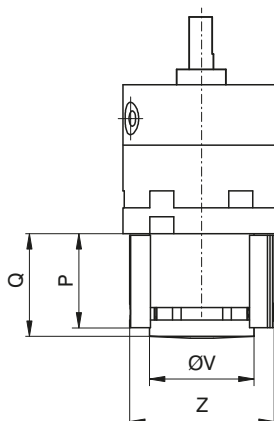

Bore - Rotation	10 - 90°	15 - 90°	20 - 90°	30 - 90°	40 - 90°	
	10 - 180°	15 - 180°	20 - 180°	30 - 180°	40 - 180°	
	10 - 270°	15 - 270°	20 - 270°	30 - 270°	40 - 270°	
ØA	30	35	44	51	64	
B	17	20,1	29,1	40	45	
ØC	4	5	6	8	10	
ØD	9	12	14	16	25	
E	3	4	4,5	5	6,5	
F	9	10	10	12	22	
G	14	18	20,3	22	30	
H	3,5	4,5	5,5	7,5	9	
J	8	9	9,6	13	15	
K	1	1,5	1,6	2	4,5	
L	4,2	5	8,5	11	9,5	
M	M5x0,8	M5x0,8	M5x0,8	M5x0,8	M5x0,8	
ØN	24	29	36	43	56	
P	23,3	28	28	30,8	33	
Q	24	29,5	30,5	34	36	
R	M3x0,5	M3x0,5	M4x0,7	M5x0,8	M5x0,8	
RR	3	3	4,5	9	9	
S	5	6	7	8	9	
T	24	28	28,5	32,5	34,5	
U	18	22	21	24	26	
ØV	18	24	30	34	34	
ØX	6	6	7,5	9	9	
XX	3,5	3,5	4,5	5,5	5,5	
ØY	2,3	2,3	3,2	4,2	4,2	
Z	29	34	42	47	47	
Weight (g)	Base	28	48	112	200	342
	With regulation rotation system	78	116	240	390	805

Overall dimensions Ø50 - Ø100

R (n° 6 threads on both sides)  
RR (useful depth)      ØVA (n° 4 holes)

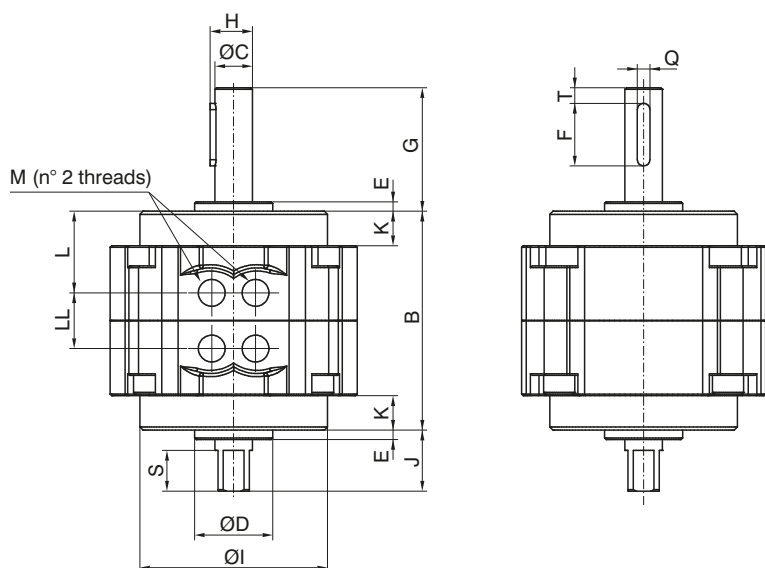
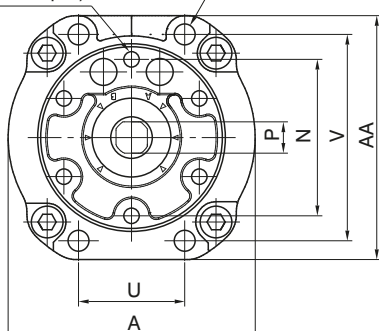

Adjustable rotation angle version

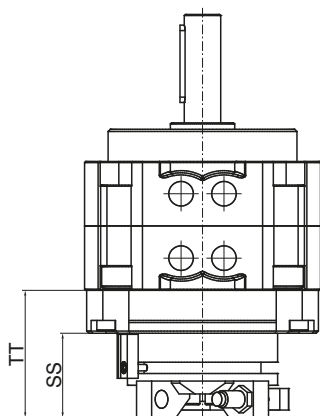

With sensor support version

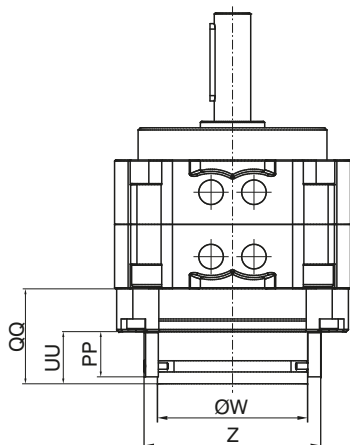

Bore - Rotation	50 - 90°	63 - 90°	80 - 90°	100 - 90°
	50 - 180°	63 - 180°	80 - 180°	100 - 180°
	50 - 270°	63 - 270°	80 - 270°	100 - 270°
A	79	98	110	140
AA	78	98	110	140
B	70	80	90	103
ØC	12	15	17	25
ØD	25	28	30	45
E	3	3	3	4
F	20	25	36	40
G	39,5	45	53,5	65
H	13,5	17	19	29
ØI	60	75	88	108
J	19,5	21	23,5	30
K	11	14	15	11,5
L	26	28,9	30	35,4
LL	18	22,2	30	32,2
M	G1/8"	G1/8"	G1/4"	G1/4"
N	50	60	70	80
P	10	12	13	19
PP	21	21	21	21
Q	4	5	5	7
QQ	39,4	43	44	48,5
R	M6x1	M8x1,25	M8x1,25	M10x1,5
RR	8	10	14	14
S	13	14	16	16
SS	38	38	39	39,5
T	5	7,5	5	5
TT	53	56,5	59	63
U	34	39	48	60
UU	24,5	24,5	24,5	24,5
V	66	83	94	120
ØVA	6,5	9	9	11
ØW	60	60	70	70
Z	73	73	83	83
Weight (g)	Base	760	1290	4100
	With regulation rotation system	1100	1690	2370

Key flat position and adjustable rotation angle Ø10 - Ø40

ROTATING SHAFT KEY FLAT POSITION

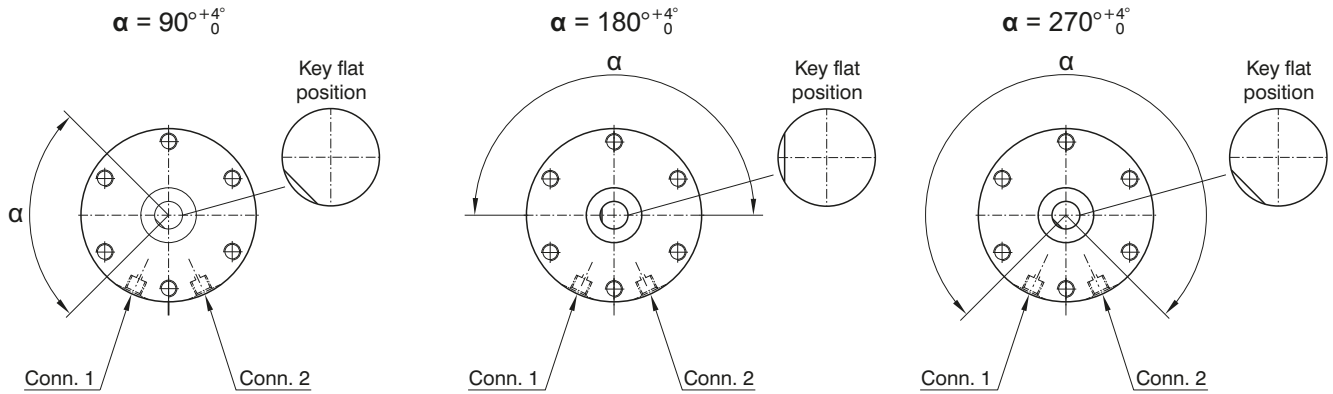

ROTATION ANGLE SETUP

To regulate the rotation angle (codes 6420..R or T), follow the instructions below

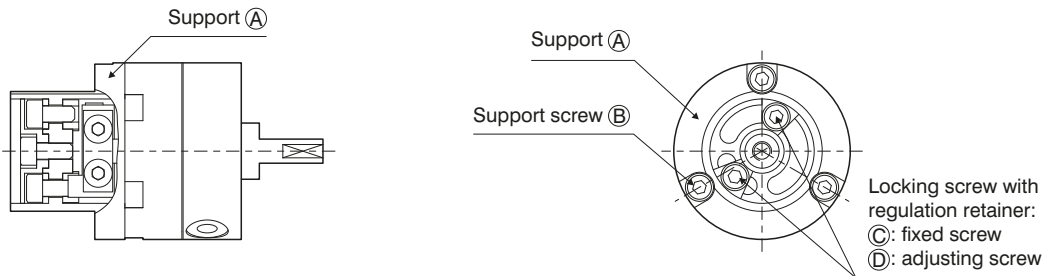

Phase 1 : Choose the regulation configuration based on the following options  
(consider the actuator base position):

rotation 90°, regulation 0 - 90°, rotation 180°, regulation 0 - 180°, rotation 270°, regulation 0 - 175°

ROTATION CONFIGURATION

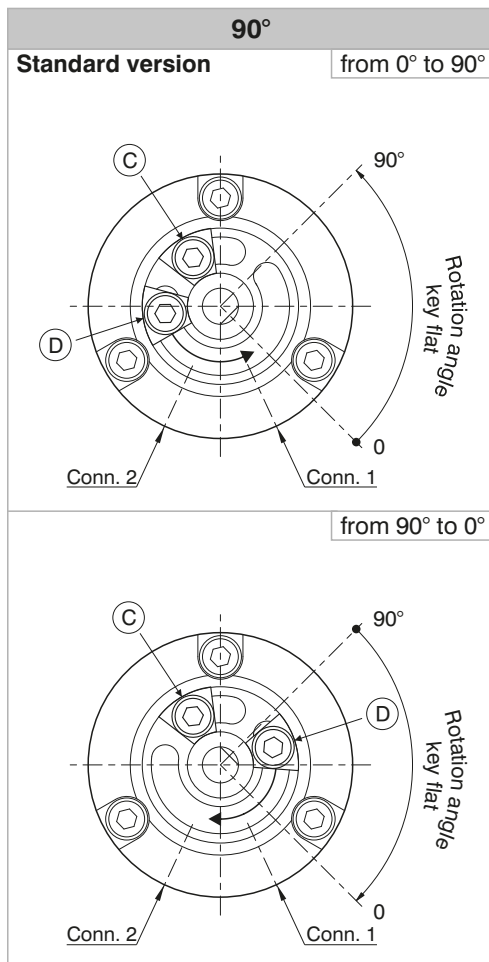

ROTATION CONFIGURATION

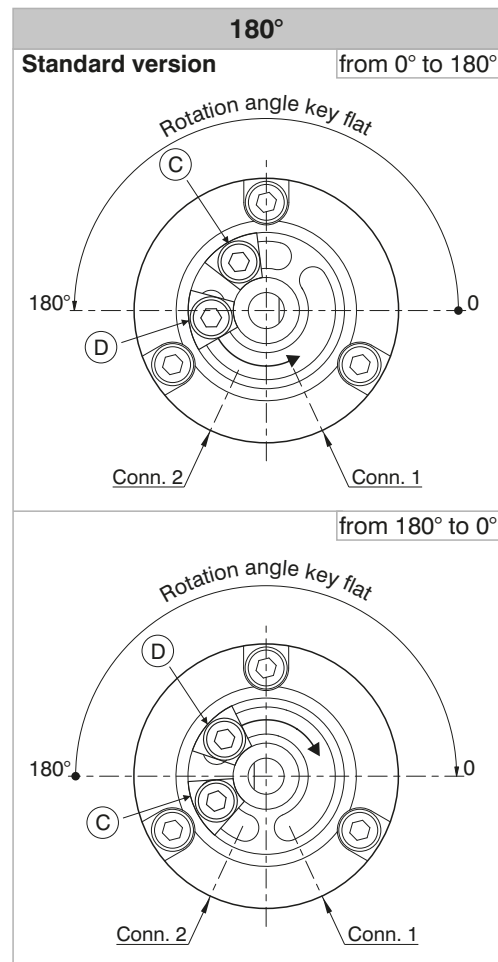

3 PNEUMATIC ACTUATION



Key flat position and adjustable rotation angle Ø10 - Ø40

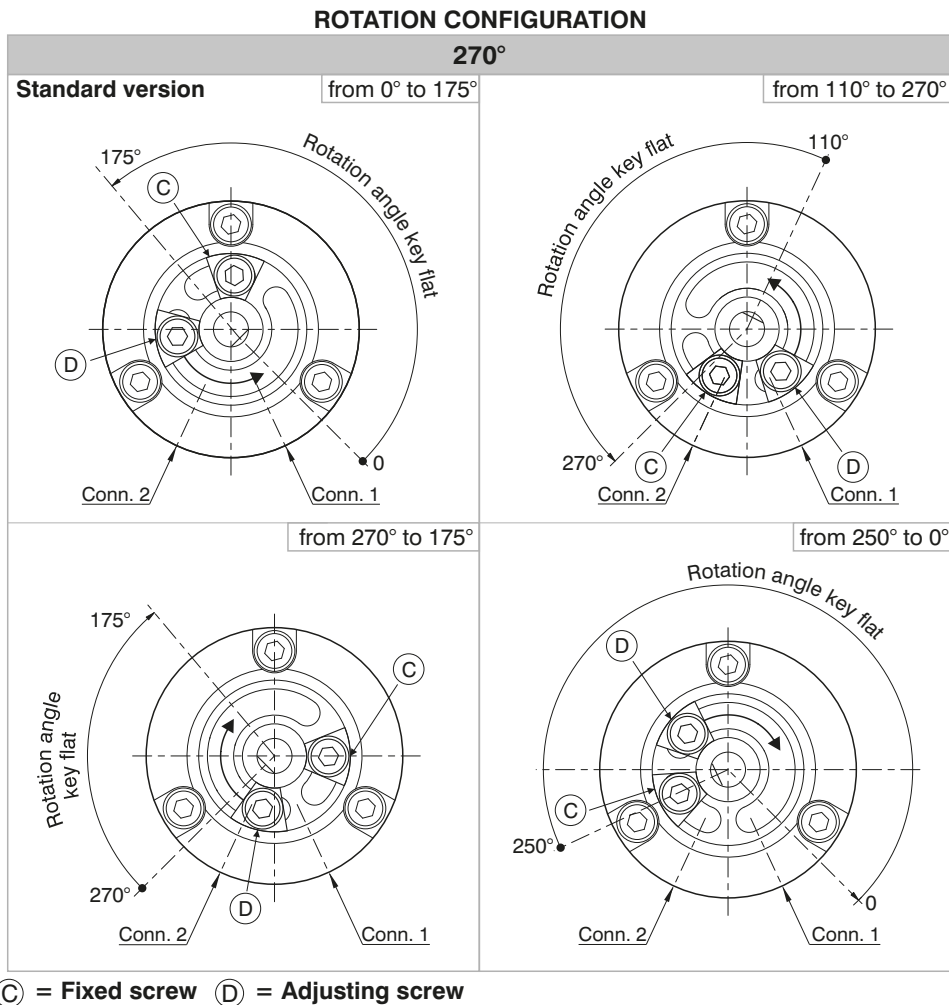

**Phase 2 :** If the desired settings do not correspond to the basic version settings:

- remove screw (E) and disk (F) or (G) (depending on the version) (see figure 1)
- remove screws (B), the actuator support (A) (see figure 1) and unlock blocking screws (C) and (D) (see rotation configuration)
- position screws (C) and (D) and the key flat of rotating shaft as indicated in the chosen rotation configuration in order to align the key flat of rotating shaft (see figure 2)
- re-assemble actuator support (A), tighten screws (B)
- position screws (C) and (D) according to the desired adjustment and tighten the screws
- re-assemble disk (F) or (G) and screw (E)

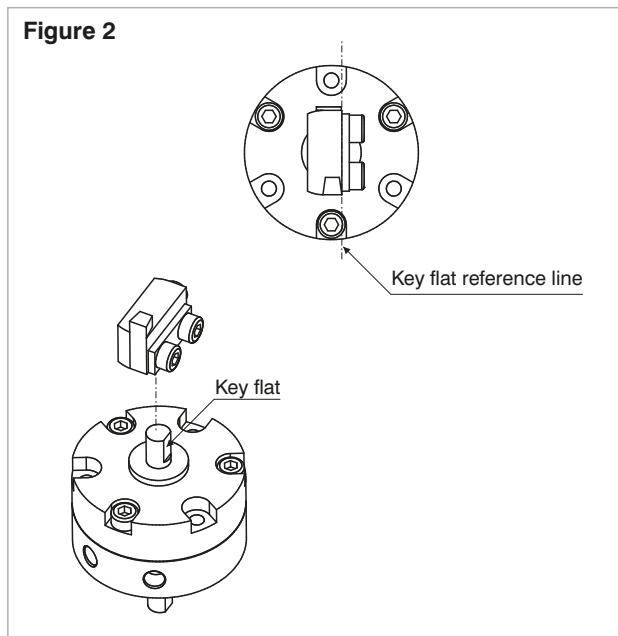
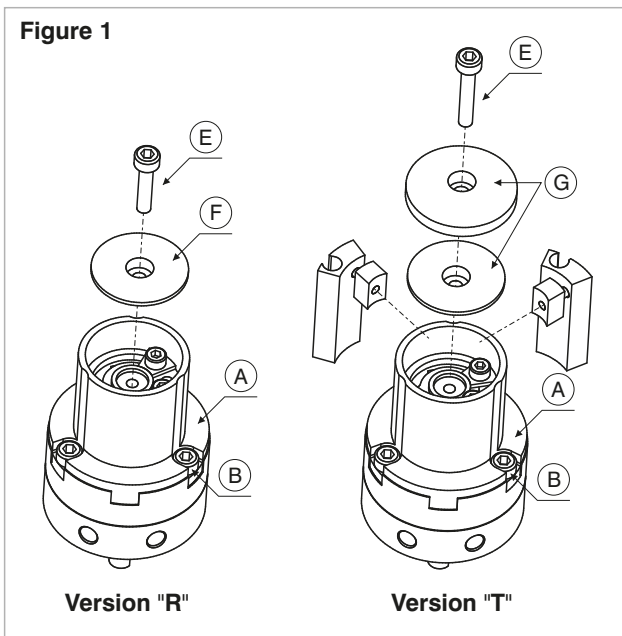

### Spline position and adjustable rotation angle Ø50-Ø100

#### ROTATING SHAFT SPLINE POSITION

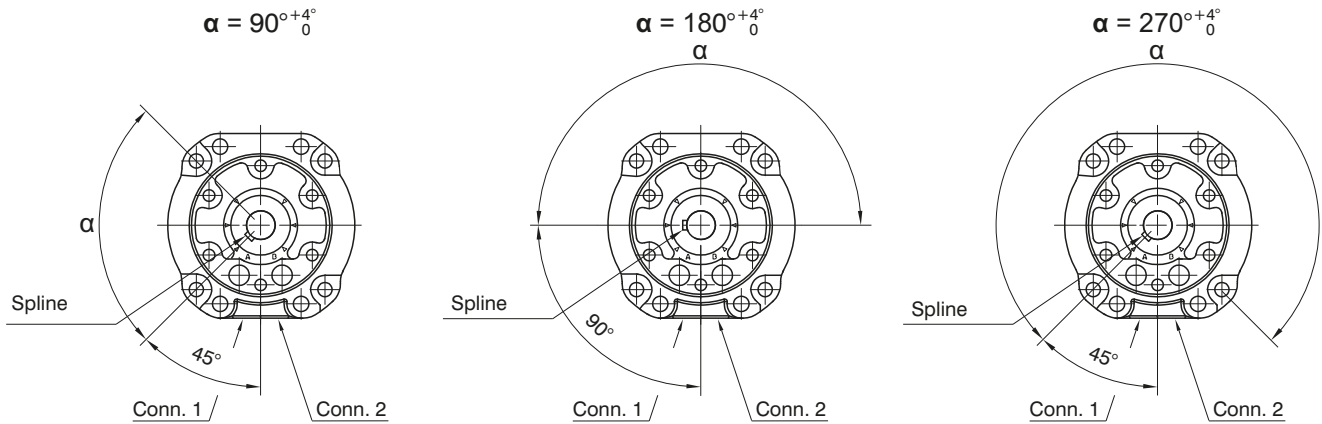

#### ROTATION ANGLE SETUP

The version with adjustable rotation angle (cod. 6420..R or T) is available with hydraulic dampers which enable to regulate the rotation angle by 15° and to decelerate moving mass.

Example: for 90° rotation and 15° regulation per decelerator, the effective rotation angle is 60°

Example: for 180° rotation and 15° regulation per decelerator, the effective rotation angle is 150°

Example: for 270° rotation and 15° regulation per decelerator, the effective rotation angle is 240°

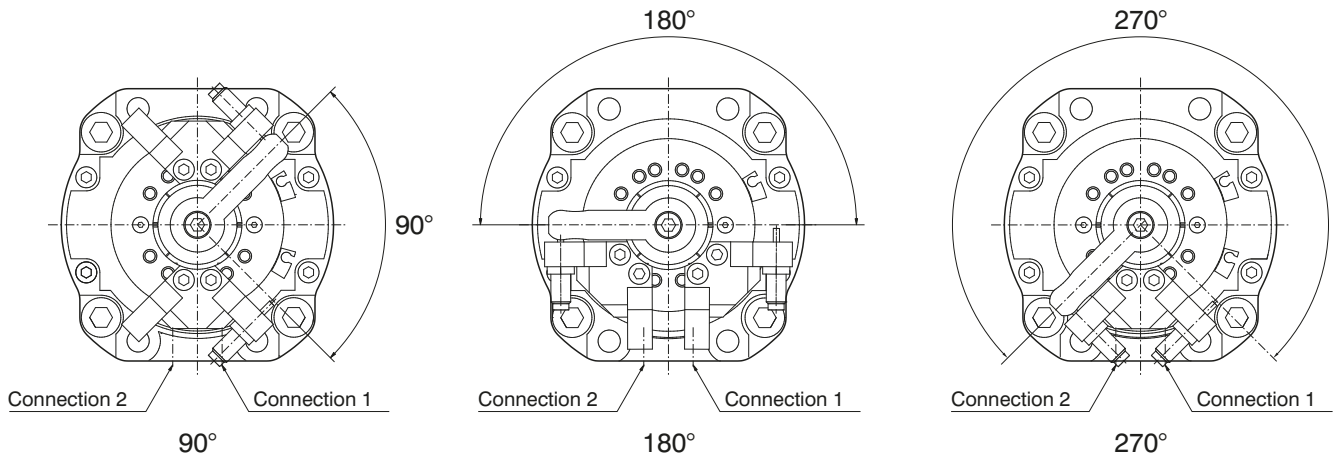

**Switch positioning instructions Ø10 - Ø40**

- Phase 1** - Unfasten screw (A)
- Phase 2** - Assemble the switch (C) into the dedicated housing (B) and lock with screw (D)
- Phase 3** - Rotate block (B) in the desired position (see following image)

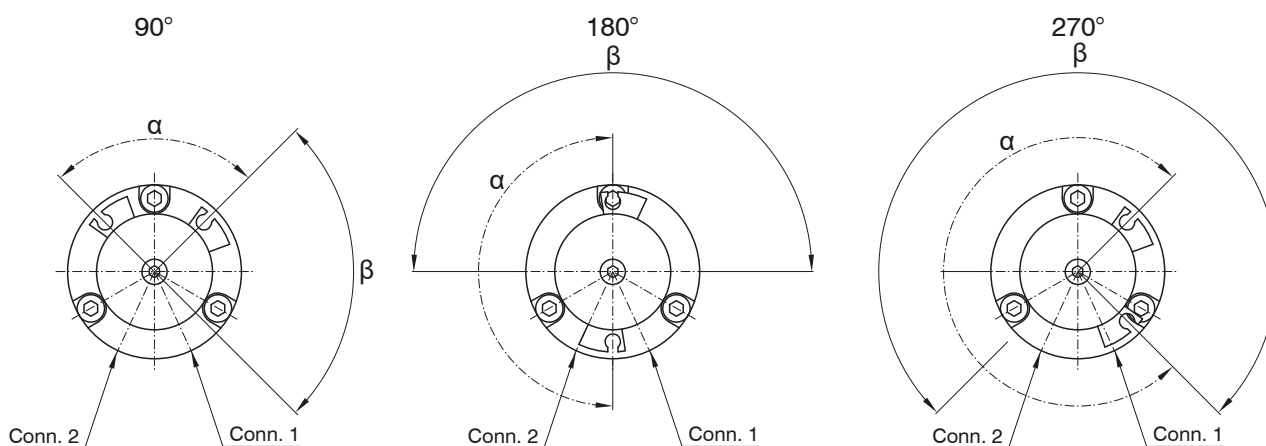
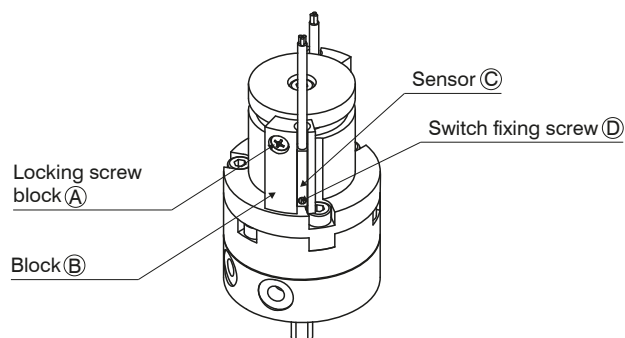

**α** - magnet rotating angle  
**β** - shaft key flat rotating angle  
 For correct functionality position the switch within angle **α**

- Phase 4** - tighten screw (A)
- Phase 5** - repeat the following phases for the second switch

**AVAILABLE SENSORS**

	Code
	1581.U
	TRS.U
	1581.HAP
	THS.P

	Code
	1583.DC
	1583.HAP
	THR.P

**3**  
PNEUMATIC ACTUATION

### Switch positioning instructions Ø50 - Ø100

**Phase 1** - Unfasten screw (A)

**Phase 2** - Assemble the switch (C) into the dedicated housing (B) and lock with screw (D)

**Phase 3** - Rotate block (B) in the desired position (see following image)

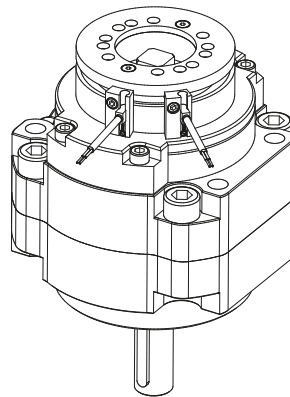
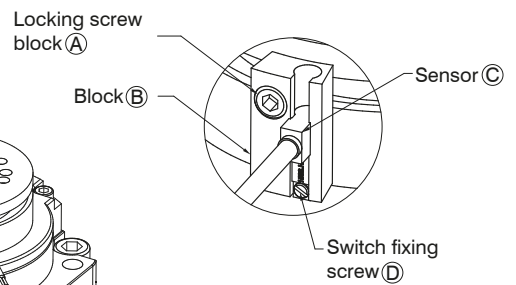

90°

180°  
 $\alpha$

270°  
 $\alpha$

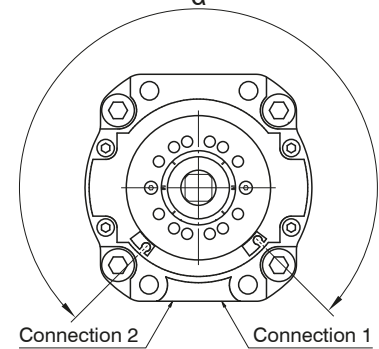
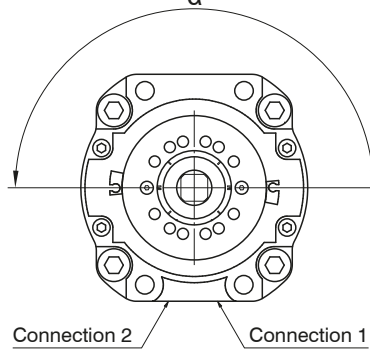
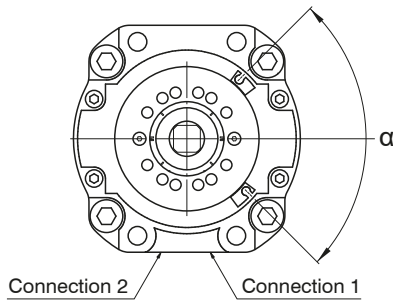

$\alpha$  - magnet rotating angle (that corresponds to the shaft key flat rotating angle)

For correct functionality position the switch within angle  $\alpha$

**Phase 4** - tighten screw (A)

**Phase 5** - repeat the following phases for the second switch

### AVAILABLE SENSORS

	Code
	1583.DC
	1583.HAP
	THR.P

Available torques

Ø10

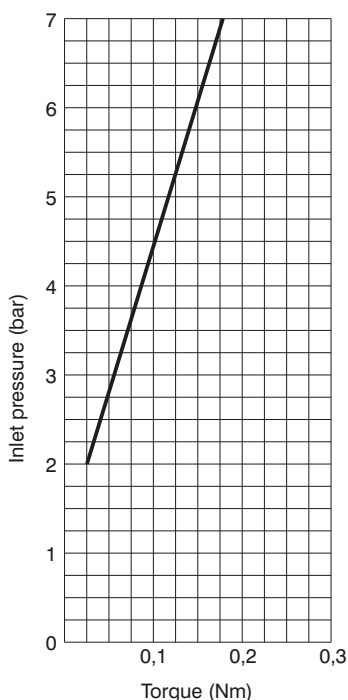

Ø15

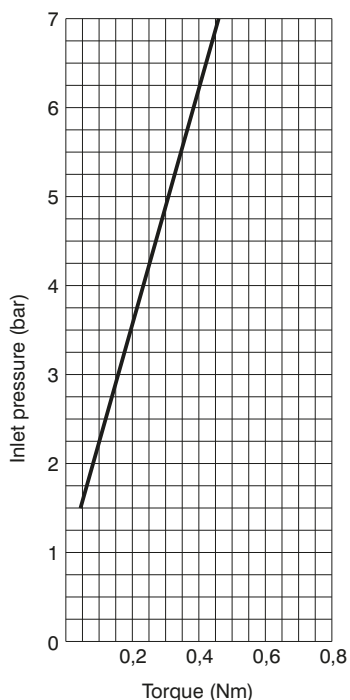

Ø20

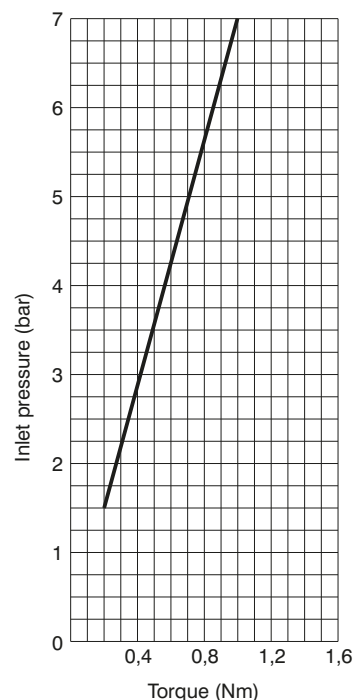

Ø30

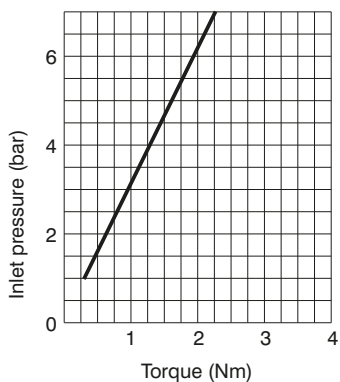

Ø40

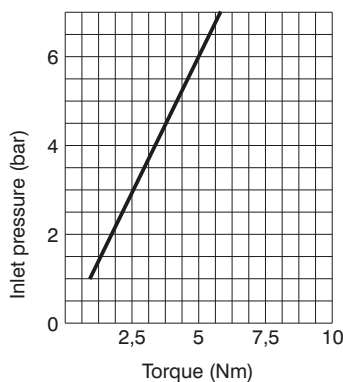

Ø50

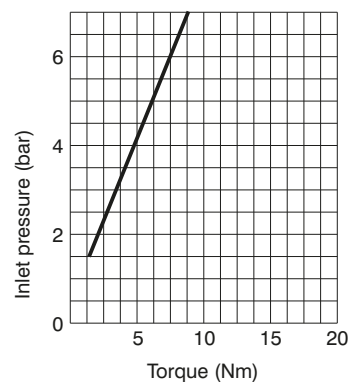

Ø63

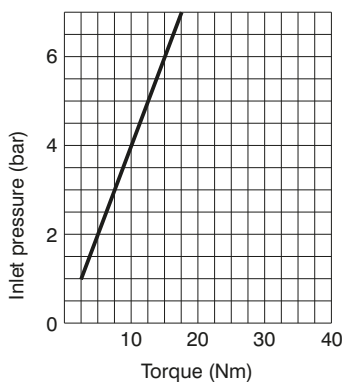

Ø80

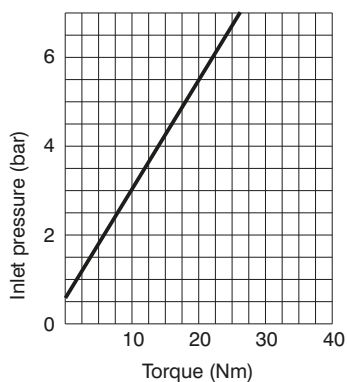

Ø100

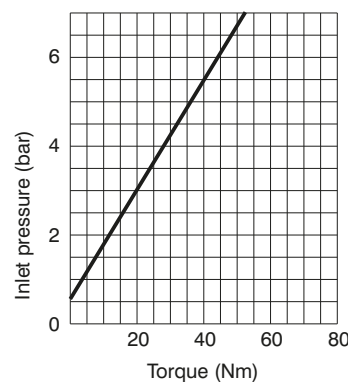

Direct mounting  
Mounting types

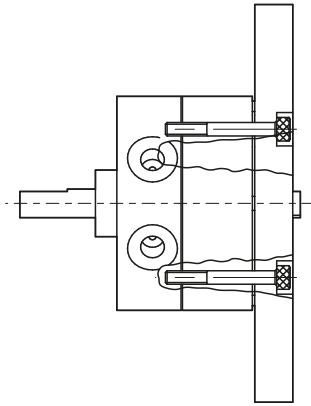

Rear mounting

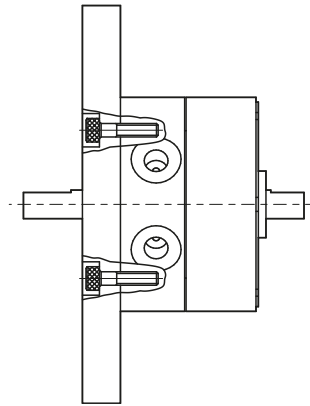

Frontal mounting

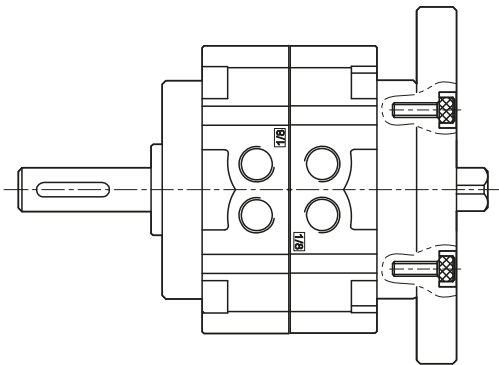

Rear mounting

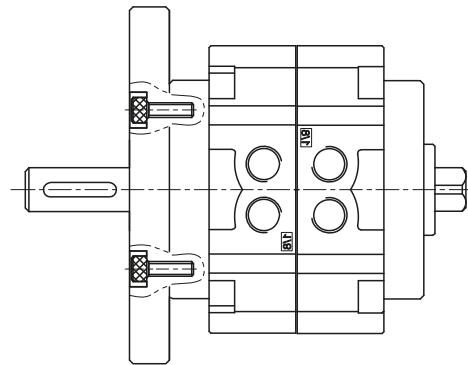

Frontal mounting

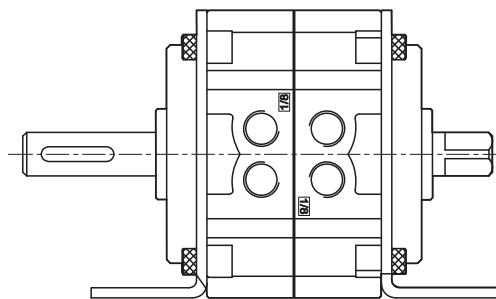

Mounting with flange



## Series 6300 - Pneumatic grippers

---

### General

Pneumatic grippers from the 6300 series are typically used in complex systems such as assembly machines, robots, manipulators etc.

This series covers the wide range requirements of this sector, allowing a variety of applications.

The range includes grippers equipped with holding fingers operating from  $-10^{\circ}$  to  $+30^{\circ}$  degrees, with  $180^{\circ}$  degree opening, or a parallel guided gripper with great rigidity throughout the stroke.

The parallel grippers cater for larger openings (three different strokes for each diameter) with synchronised operation via a pinion-rack system with high strength thanks to a double piston mechanism.

For the typical application of supplying a piece upon to a machine tool, make provision for an automatic three-pronged movement carried along by a wedge mechanism, containing the elevated force dimensions.

The holding fingers can have a tolerance reference as a precise fixing device for the catching mechanism. Every type of "hand" offers different functional levels of performance at varying diameters and lengths, secondary to the application by the "fingers".

**Pneumatic grippers, angular - Standard version**



**Ordering code**

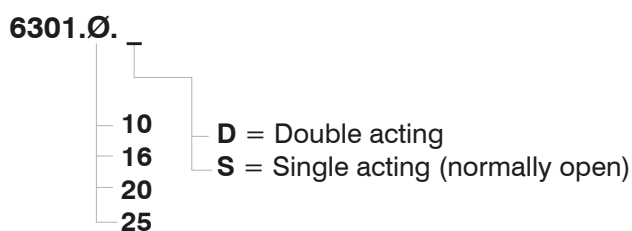

**Construction characteristics**

Body	anodised aluminium
Piston	AISI 303 stainless steel
Fingers	nitrate steel
End cap	anodised aluminium
Seals	oil resistant NBR rubber

**Operational characteristics**

Fluid	Filtered air. No lubrication needed, if applied it shall be continuous.		
Working pressure	1 - 6 bar (double acting) - 2.5 - 6 bar (single acting)		
Operating temperature	-5°C - +70°C		
Opening total stroke	-10° - 30°		
Holding force (Nm) at 5 bar	Bore - Double acting - Single acting		
	Ø10	0.1	0.07
	Ø16	0.4	0.30
	Ø20	0.7	0.55
	Ø25	1.35	1.08
Maximum operating frequency	from Ø10 to Ø25, 190 cycles/minute		

3 PNEUMATIC ACTUATION



Overall dimensions

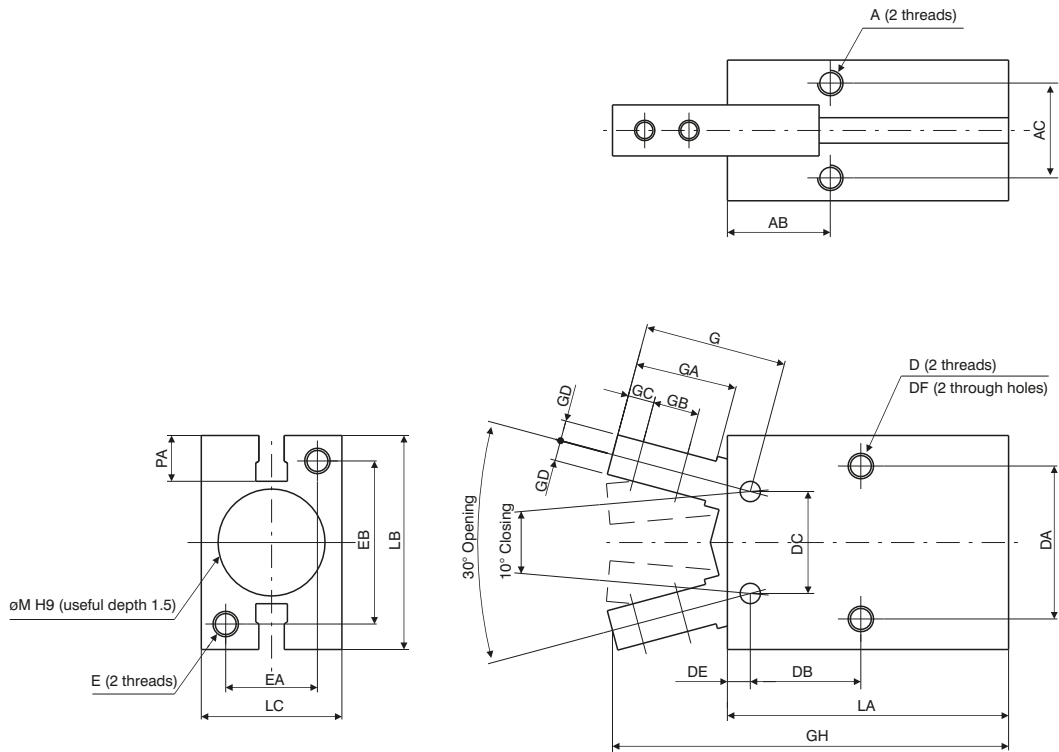

Bore	Ø10	Ø16	Ø20	Ø25
<b>A</b>	M3x0,5	M4x0,7	M5x0,8	M6
Useful depth	6	6,5	8	10
<b>AB</b>	11,6	14,6	20,2	23,9
<b>AC</b>	11,4	16	18,6	22
<b>C</b>	M2,5x0,45	M3x0,5	M4x0,7	M5x0,8
<b>D</b>	M3x0,5	M4x0,7	M5x0,8	M6
Useful depth	5	8	10	12
<b>DA</b>	16	24	30	36
<b>DB</b>	12,8	16,2	21,7	25,8
<b>DC</b>	10	16	20	25
<b>DE</b>	2,8	3,9	4,5	4,6
<b>DF</b>	2,6	3,4	4,3	5,1
<b>E</b>	M3x0,5	M4x0,7	M5x0,8	M6
Useful depth	6	8	10	12
<b>EA</b>	12	15	18	22
<b>EB</b>	18	22	32	40
<b>F</b>	M3x0,5	M5x0,8	M5x0,8	M5x0,8
<b>FA</b>	11	13	15	20
<b>FB</b>	7,2	7	7,5	7,7
<b>FC</b>	18,8	18,3	22,2	23,5
<b>G</b>	17,2	22,6	28	37,5
<b>GA</b>	12	16	20	27
<b>GB</b>	5,7	7	9	12
<b>GC</b>	3	4	5,2	8
<b>GD</b>	2	3,5	4	5
<b>GH</b>	52,4	62,5	78,7	92
<b>GL</b> <sup>0/-0,1</sup>	6,4	8	10	12
<b>LA</b>	38,6	44,6	55,2	60,4
<b>LB</b>	23	30,6	42	52
<b>LC</b>	16,4	23,6	27,6	33,6
<b>M</b> <sup>H9</sup>	11	17	21	26
<b>PA</b>	5,4	5,8	9	11,5
Weight (g)	40	90	180	315

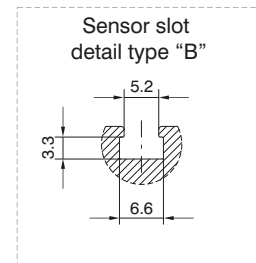
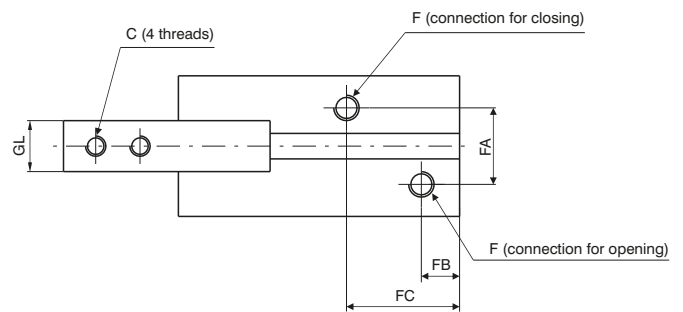



**Gripping force 5 bar (Nm)**

Bore	Ø10	Ø16	Ø20	Ø25
Double acting (Nm)	0,1	0,4	0,7	1,35
Single acting (Nm)	0,07	0,3	0,55	1,08

**NOTE:**

Bore selection should be made considering a holding force 10 to 20 times the component weight.  
 In case of acceleration/deceleration a further margin of safety should be considered.

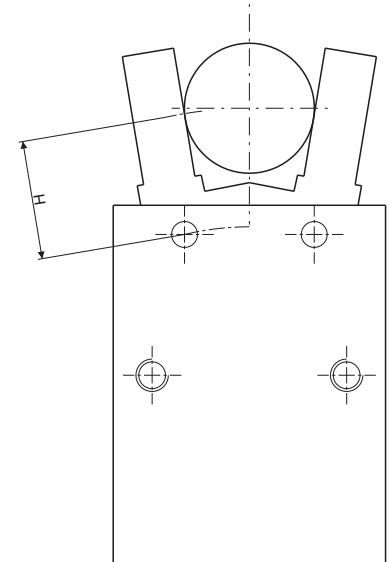
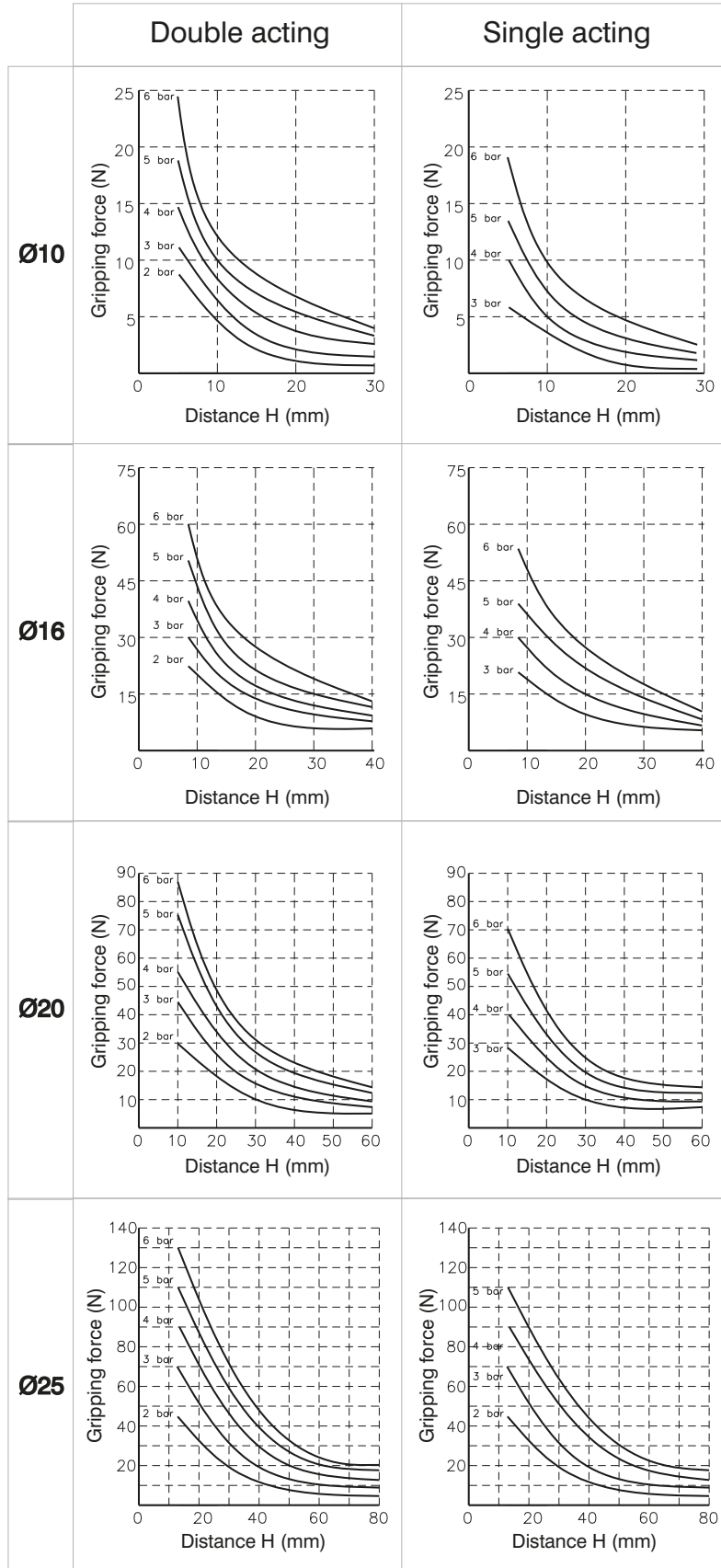

3 PNEUMATIC ACTUATION

► Pneumatic grippers, 180° angular



Ordering code

6302.Ø.D

10  
16  
20  
25

Construction characteristics

Body	anodised aluminium
Piston	aluminium
Fingers	steel
End cap	anodised aluminium

Operational characteristics

Function	double acting
Fluid	Filtered air. No lubrication needed, if applied it shall be continuous.
Working pressure	1 - 6 bar
Working temperature	-5C° - +70C°
Opening total stroke	-3° - 180°
Maximum operating frequency	from Ø10 to Ø25, 60 cycles/minute

**Overall dimensions**

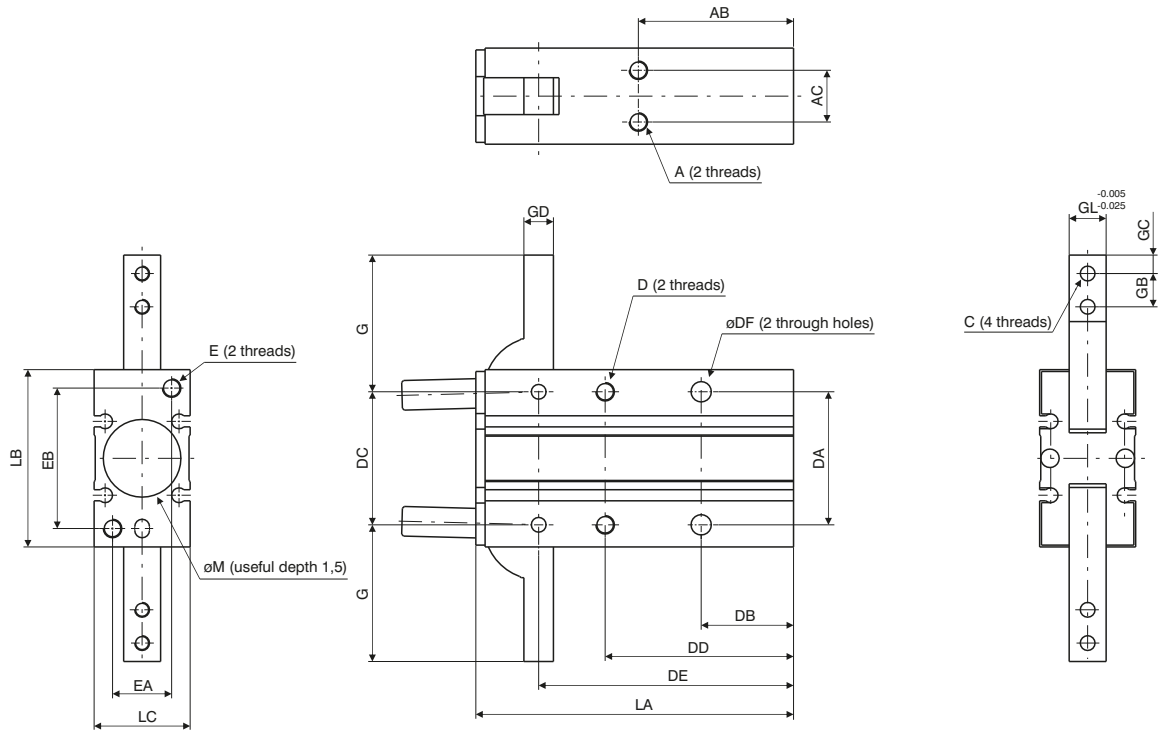

Bore	Ø10	Ø16	Ø20	Ø25
A	M3x0,5	M4x0,7	M5x0,8	M6x1
Useful depth	4	5	8	10
AB	30	33	42	50
AC	9	12	14	16
C	M3x0,5	M3x0,5	M4x0,7	M5x0,8
D	M3x0,5	M4x0,7	M5x0,8	M6x1
Useful depth	6	8	10	12
DA	24	30	36	42
DB	18	20	25	30
DC	22	28	36	45
DD	35	41	51	60
DE	47,5	55,5	69	86
DF	3,4	4,5	5,5	6,6
E	M3x0,5	M4x0,7	M5x0,8	M6x1
Useful depth	6	8	10	12
EA	9	12	16	18
EB	24	30	38	46
F	M5x0,8	M5x0,8	M5x0,8	M5x0,8
FA	3	8	2	14
FB	7	7	8	8
FC	23	25	32	42
G	23,5	28,5	37	45
GB	6	7	9	12
GC	3	4	5	6
GD	4	5	8	10
GL	6	8	10	12
LA	58	69	86	107
LB	30	38	48	58
LC	15	20	26	30
N	4	4	5	5
Useful depth	3	3	4	4
NA	9	15	19	23
ØM <sup>H9</sup>	11	17	21	26
ØNB <sup>H9</sup>	3	3	4	4
P	2	2,5	3	3
PA	13	18	20	24
Weight (g)	70	150	320	550

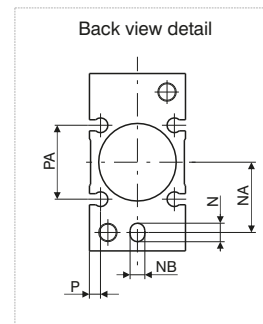
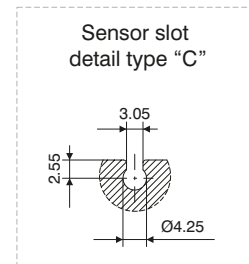

PNEUMATIC ACTUATION

Operating criteria

Gripping force 5 bar (Nm)

Bore	Ø10	Ø16	Ø20	Ø25
(Nm)	0,16	0,54	1,1	2,28

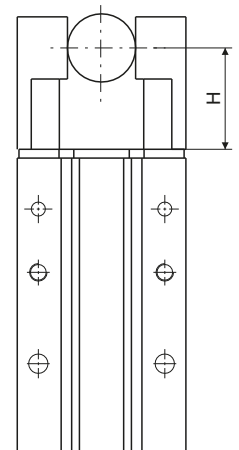
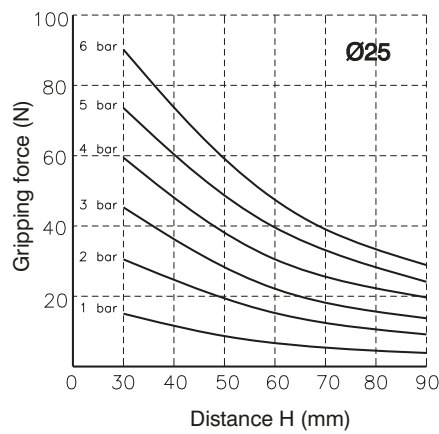
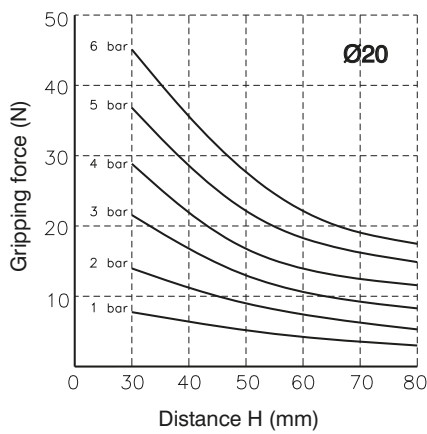
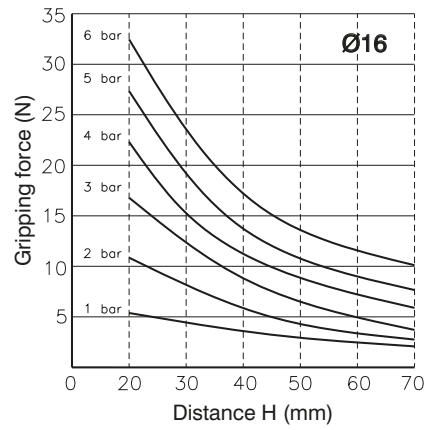
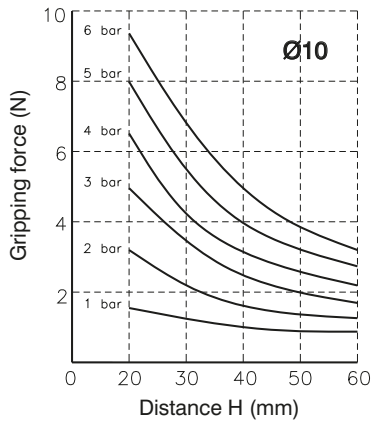

3 PNEUMATIC ACTUATION

Confirmation of Holding point

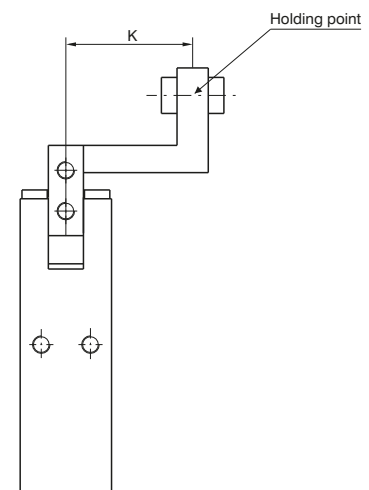
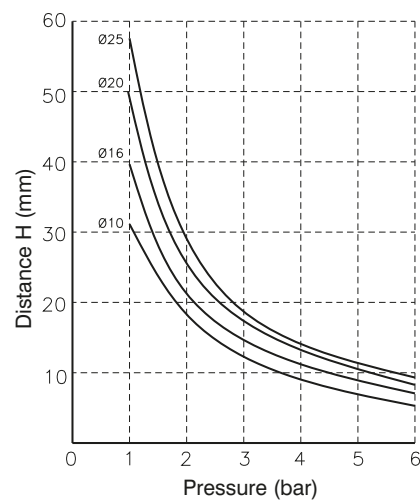

Applications where the holding point is outside the recommended parameters shown on the above graph might affect the product life.



► **180° angular gripper rack & pinion style**



**Ordering code**

**6303.Ø.D**

F = Fingers, end fixing  
 L = Fingers, side fixing

- 20
- 25
- 32
- 40
- 50

**Construction characteristics**

Body	anodised aluminium
Piston	aluminium
Fingers	steel
End cap	anodised aluminium

**Operational characteristics**

Function	double acting
Fluid	Filtered air. No lubrication needed, if applied it shall be continuous.
Working pressure	1.5 - 7 bar
Working temperature	-5C° - +70C°
Opening total stroke	-5° - 180°
Maximum operating frequency	from Ø20 to Ø25, 60 cycles/minute from Ø32 to Ø50, 30 cycles/minute

Overall dimensions

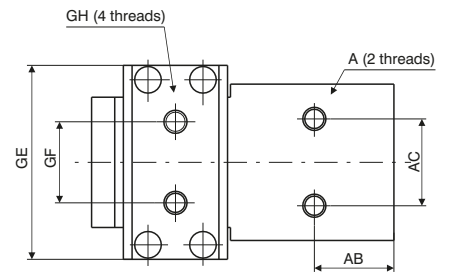
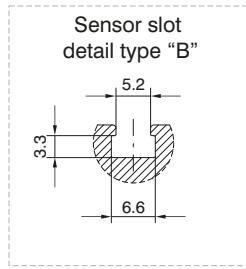

Bore		Ø20	Ø25	Ø32	Ø40	Ø50
A		M5	M6	M6	M8	M10
	Useful depth	7	10	10	15	20
AB		17	20	21	27,5	36
AC		20	24	24	30	40
D		M5	M6	M6	M8	M10
	Useful depth	10	12	12	16	20
DA		27	34	42	54	70
DB		35	40	47	56,5	69
DC		18	24	30	40	56
DD		23	27	29	37,5	48
DE		45	51	61,5	75,5	96
E		M5	M6	M6	M8	M10
	Useful depth	10	12	12	15	20
EA		26	30	30	36	40
EB		26	30	45	60	80
F		M5	M5	G1/8	G1/8	G1/4
FA		12	16	20	20	30
FB		9	10	13	14	16
FC		20	23	25	33,5	44
G		23	27	32	42	58
GA		7	8	9	12	17
GB		2	2	2	3	4
GC		12	17	23	30	44
GD		16	21	27	36	52
GE		41	45	51	67	85
GF		18	20	20	28	38
GH		M4	M5	M6	M8	M10
H		5	6	7	9	13
HA		10	12	14	21	24
HB		5	6	7	10	13
HC		28	30	34	44	58
HD		14	16	18	24	30
LA		60	69	83,5	104,5	136
LB		36	45	58	80	112
LC		36	40	45	56	66
ØM <sup>H9</sup>		21	26	34	42	52
	Useful depth	3	3	4	4	5
P		6	5,5	5,5	6	6
PD		4	4,5	11	10	13
Weight (g)		300	500	900	2100	5000

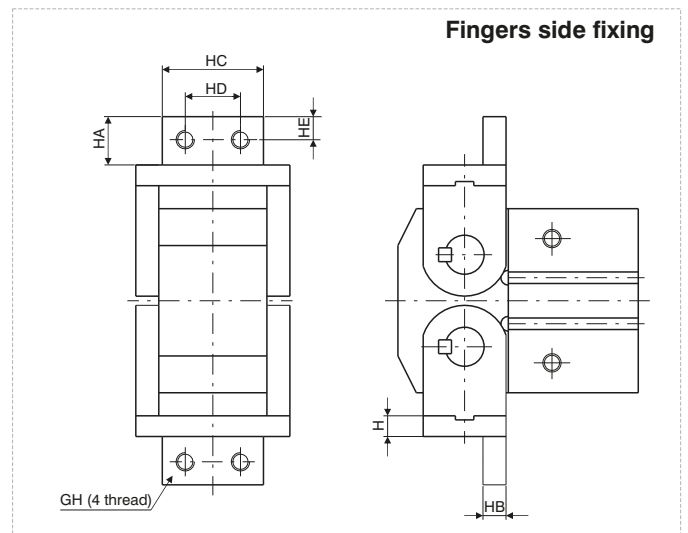
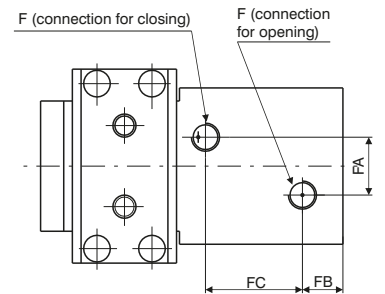
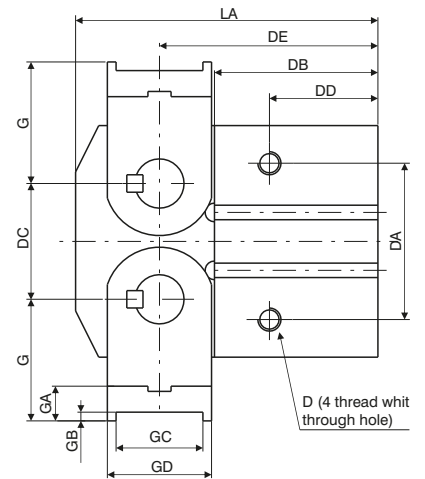
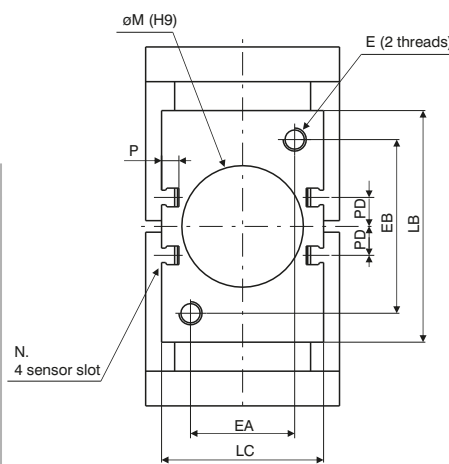



**Operating criteria**

**Gripping force**

**NOTE:**

Bore selection should be made considering a holding force 10 to 20 times the component weight.  
 In case of acceleration/deceleration a further margin of safety should be considered.

Bore	Ø20	Ø25	Ø32	Ø40	Ø50
(Nm)	0,3	0,7	1,6	3,7	8,3

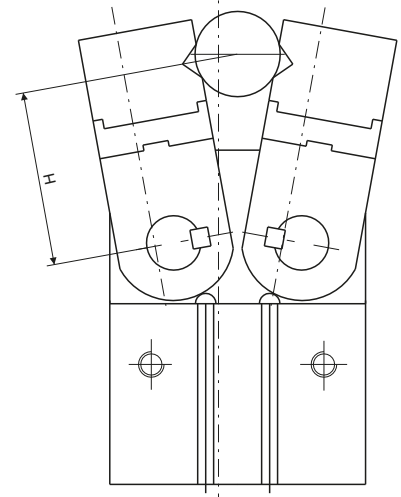
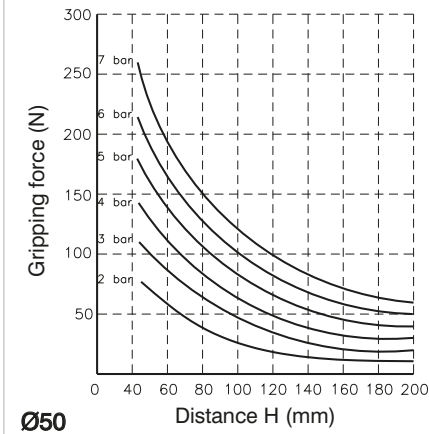
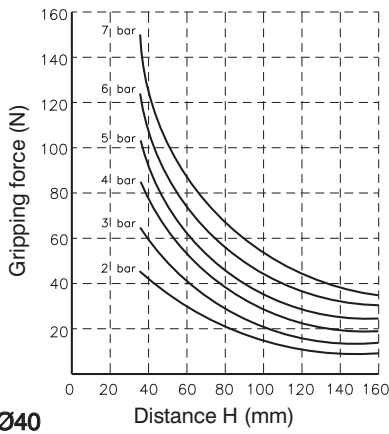
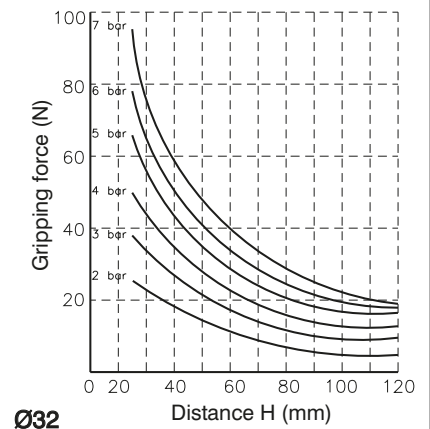
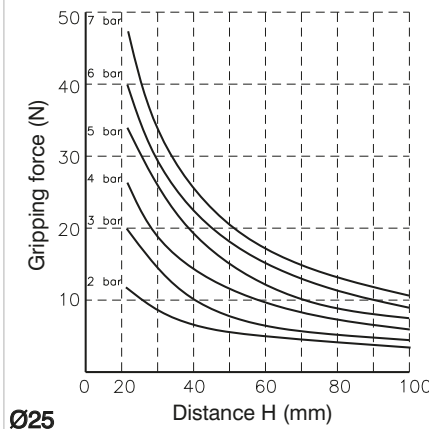
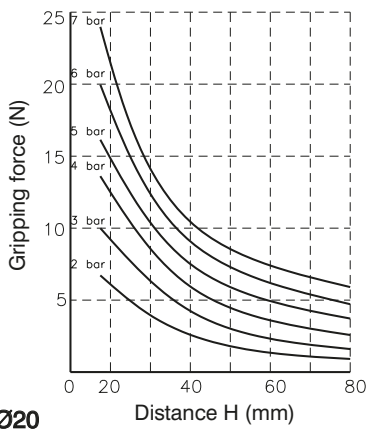

PNEUMATIC ACTUATION





▶ Parallel style pneumatic grippers - Standard version



Ordering code

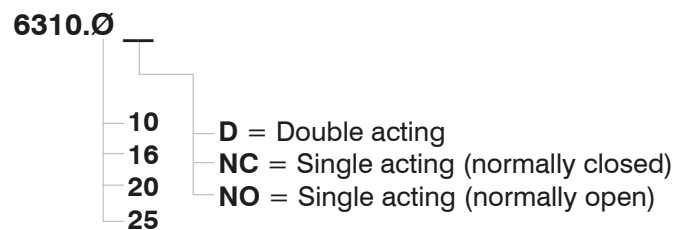

Construction characteristics

Body	anodised aluminium
Piston	aluminium or stainless steel (depending on the bore)
Fingers	steel
End cap	anodised aluminium
Seals	oil resistant NBR rubber

Operational characteristics

Fluid	Filtered air. No lubrication needed, if applied it shall be continuous.
Working pressure	double acting : 2 - 7 bar (for $\varnothing 10$ ) - 1 - 7 (for other bores) single acting : 3.5 - 7 bar (for $\varnothing 10$ ) - 2.5 - 7 ( for other bores)
Operating temperature	-5°C - +70°C
Maximum operating frequency	from $\varnothing 10$ to $\varnothing 25$ , 180 cycles/minute

**Overall dimensions**

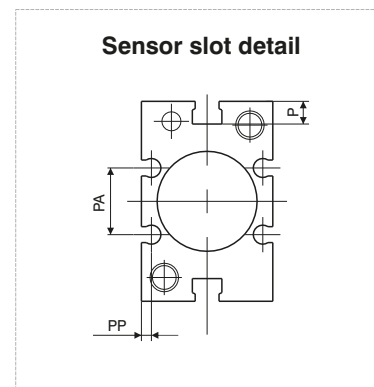
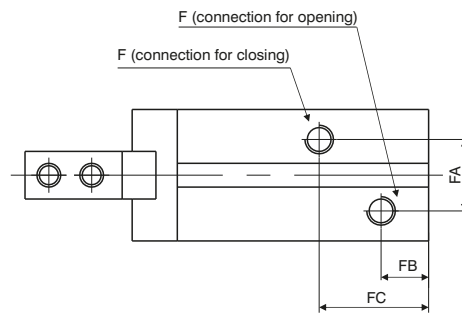
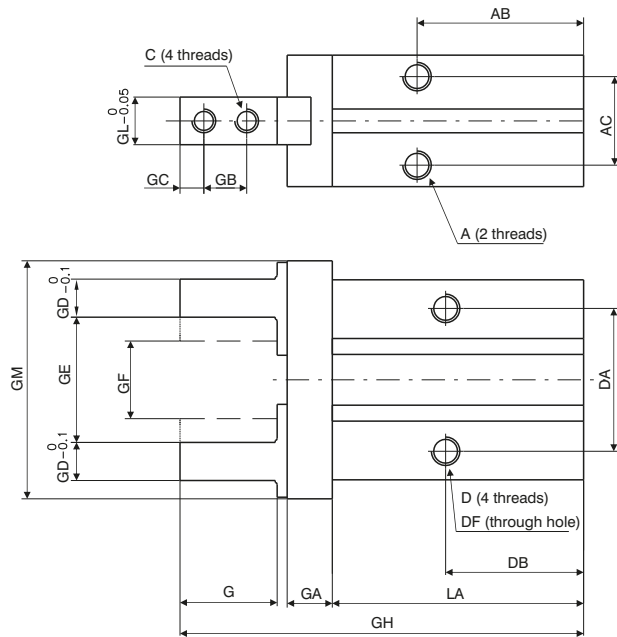
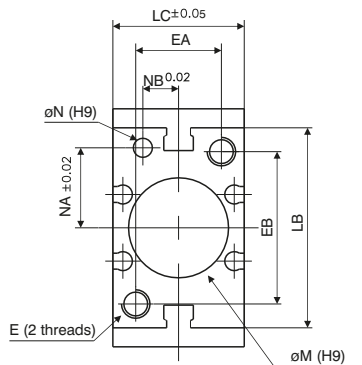

**Ø16 - Ø25**

Sensor slot detail type "C"

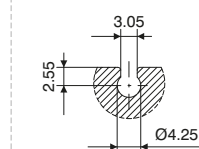

**Ø10 - Ø25**

Sensor slot detail type "B"

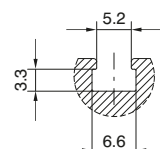

Bore		Ø10	Ø16	Ø20	Ø25
A		M3x0,5	M4x0,7	M5x0,8	M6x1
	Useful depth	6	4,5	8	10
AB		27	30	35	36,5
AC		11,4	16	18,6	22
C		M2,5x0,45	M3x0,5	M4x0,7	M5x0,8
D		M3x0,5	M4x0,7	M5x0,8	M6x1
	Useful depth	5,5	8	10	12
DA		16	24	30	36
DB		23	24,5	29	30
ØDF		2,6	3,4	4,3	5,1
E		M3x0,5	M4x0,7	M5x0,8	M6x1
	Useful depth	6	8	10	12
EA		12	15	18	22
EB		18	22	32	40
F		M3x0,5	M5x0,8	M5x0,8	M5x0,8
FA		11	13	15	20
FB		9	7,5	10	10,7
FC		19	19	23	23,5
G		12	15,5	20	25
GA		6	7,5	9,5	11
GB		5,7	7	9	12
GC		3	4	5	6
GD		4	5	8	10
GE		15,2	20,9	26,3	33,3
GF		11,2	14,9	16,3	19,3
GH		57	67,5	84,8	102,7
GL		5	8	10	12
GM		29	38	50	63
LA		37,8	42,5	52,8	63,6
LB		23	30,6	42	52
LC		16,4	23,6	27,6	33,6
ØM <sup>H9</sup>		11	17	21	26
	Useful depth	2	2	3	3,5
ØN <sup>H9</sup>		2	3	4	4
	Useful depth	3	3	4	4
NA		7,6	11	16,8	21,8
NB		5,2	6,5	7,5	10
P		5,4	5,8	9	11,5
PA		/	11,6	14	19
PP		/	2,1	2,1	3,5
Weight (g)		55	120	230	425

PNEUMATIC ACTUATION

Operating criteria

Holding force (N) (pressure 5 bar, holding point H=20 half stroke)

Version	Force	Bore			
		Ø10	Ø16	Ø20	Ø25
Double acting	Fe	9,8	30	42	65
	Fi	17	40	66	104
Single acting	N.O. Fe	6,3	24	28	45
	N.C. Fi	12	31	56	83

Fe = external holding force      Fi = internal holding force

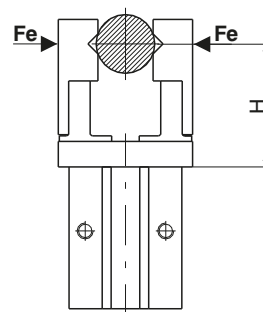

EXTERNAL HOLD

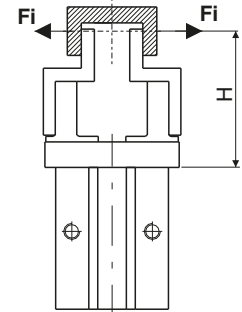

INTERNAL HOLD

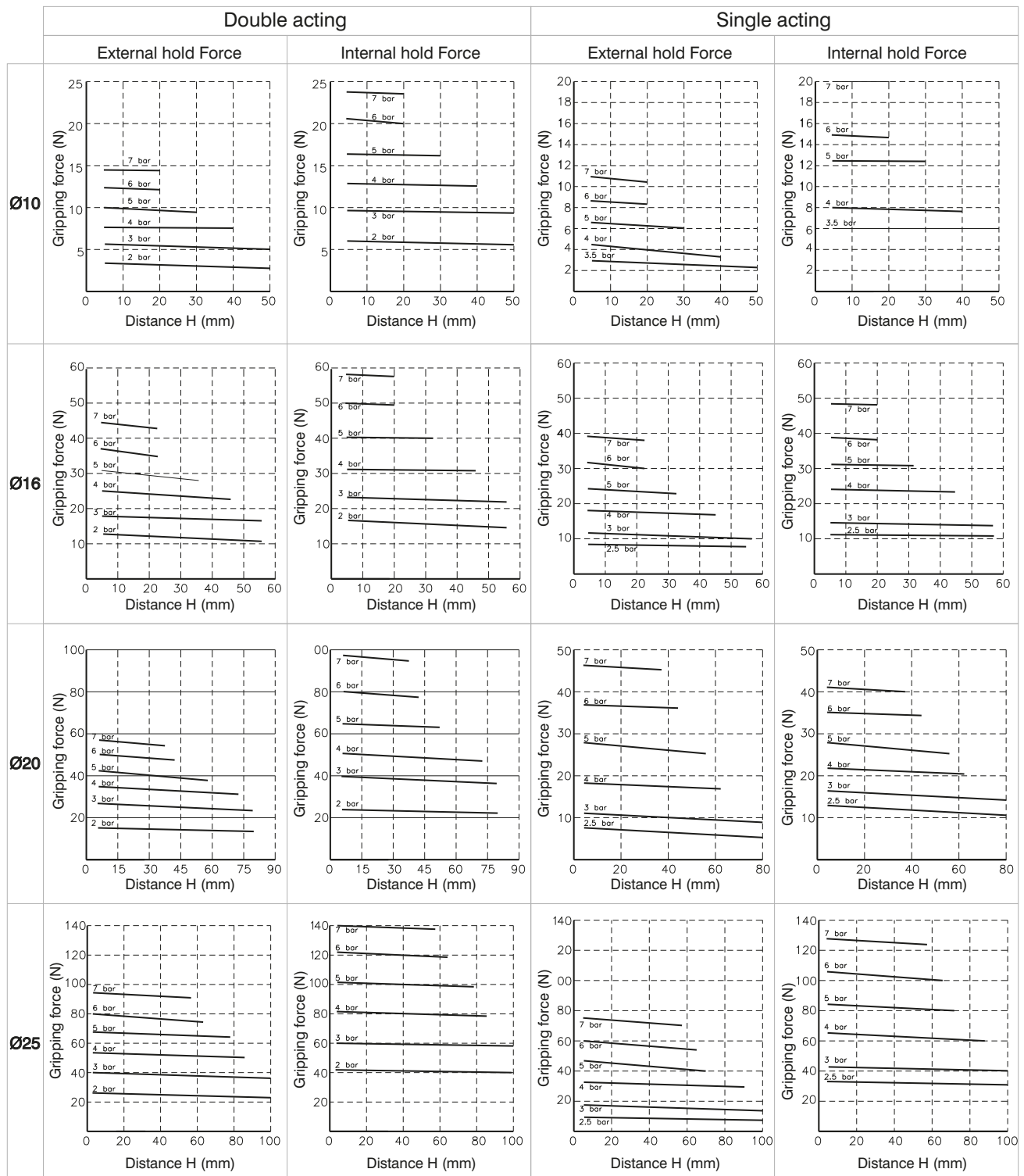

3

PNEUMATIC ACTUATION



Parallel style pneumatic grippers - Wide opening



Ordering Code

6311.Ø.D.	10	16	20	25	32	40	Ordering code options	Stroke					
								20	30	40	50	70	100
							1	40	60	80	100	120	160
							2	60	80	100	120	160	200
								Ø10	Ø16	Ø20	Ø25	Ø32	Ø40
								Bore					

Construction characteristics

Body	anodised aluminium
Piston	aluminium
Fingers	anodised aluminium
Rod	steel
Rack	steel
Pinion	steel

Operational characteristics

Function	double acting
Fluid	Filtered air. No lubrication needed, if applied it shall be continuous.
Working pressure	Ø10: 1.5 - 6 bar - Ø16 - 40: 1 - 6 bar
Working temperature	-5°C - +70°C

Model	Diameter (mm)	Max.operating frequency cycles/min.	Model	Diameter (mm)	Max.operating frequency cycles/min.
6311.10.D	10	60	6311.25.D	25	60
6311.10.D.1		40	6311.25.D.1		40
6311.10.D.2			6311.25.D.2		
6311.16.D	16	60	6311.32.D	32	30
6311.16.D.1		40	6311.32.D.1		20
6311.16.D.2			6311.32.D.2		
6311.20.D	20	60	6311.40.D	40	30
6311.20.D.1		40	6311.40.D.1		20
6311.20.D.2			6311.40.D.2		

Overall dimensions

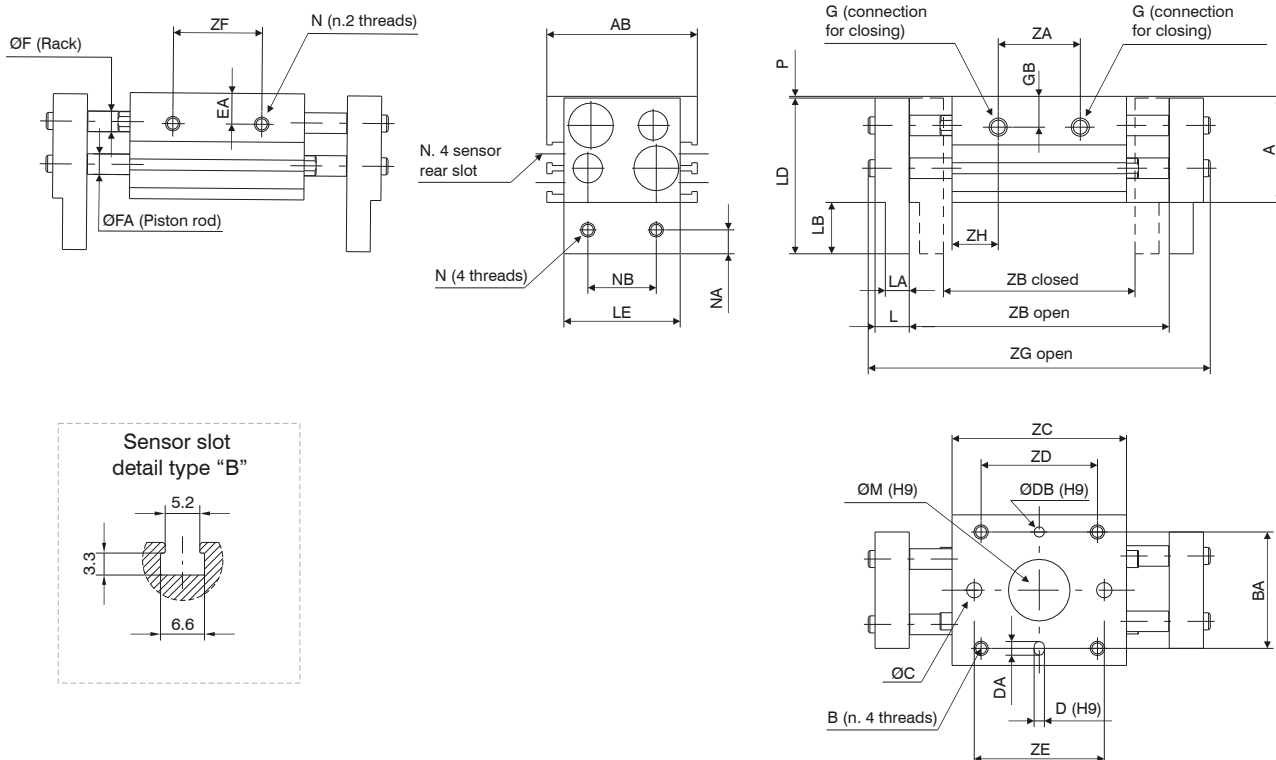

Bore	Ø10	Ø16	Ø20	Ø25	Ø32	Ø40													
<b>A</b>	31	39	46	52	68	79													
<b>AB</b>	44	55	65	76	82	98													
<b>B</b>	M4x0,7	M5x0,8	M6x1	M8x1.25	M8x1.25	M10x1.5													
Useful depth	8	10	12	16	16	20													
<b>BA</b>	34	42	52	62	64	76													
<b>ØC</b>	4,5	5,5	6,6	9	/	/													
<b>D</b> <sup>H9</sup>	3	3	4	4	6	6													
Useful depth	3	3	4	4,5	8	8													
<b>DA</b>	4	4	5	5	7	7													
<b>ØDB</b> <sup>H9</sup>	3	3	4	4	6	6													
Useful depth	3	3	4	4,5	8	8													
<b>E</b>	M4x0,7	M5x0,8	M6x1	M8x1.25	M8x1.25	M10x1.5													
Useful depth	5	7	7	7	11	16													
<b>EA</b>	9	10	11	12,5	22	28													
<b>ØF</b>	6	8	10	12	14	16													
<b>FA</b>	6	8	10	12	16	20													
<b>G</b>	M5x0,8	M5x0,8	M5x0,8	M5x0,8	G1/8	G1/8													
<b>GB</b>	9	10	11	16	16	18													
<b>L</b>	10	13	17	21	24	28													
<b>LA</b>	7	9	12,5	14	15	18													
<b>LB</b>	15	19	24	29	32	38													
<b>LD</b>	45,5	57,5	69	80	100	117													
<b>LE</b>	34	43	54	64	70	86													
<b>ØM</b> <sup>H9</sup>	18	23	27	32	35	40													
Useful depth	1,5	1,5	1,5	1,5	1,5	1,5													
<b>N</b>	M4x0,7	M5x0,8	M6x1	M8x1,25	M10x1,5	M10x1,5													
<b>NA</b>	7	8	10	12	15	18													
<b>NB</b>	20	25	30	40	50	60													
<b>P</b>	0,5	0,5	1	1	1	1													
<b>ZA</b>	24	39	57	26	50	70	32	68	88	38	86	104	54	104	148	72	130	170	
<b>ZB</b>	closed	56	78	96	68	110	130	82	142	162	100	182	200	150	198	242	188	246	286
open	76	118	156	98	170	210	122	222	262	150	282	320	220	318	402	288	406	486	
<b>ZC</b>	51	67	85	60	90	110	71	113	133	88	142	160	110	158	202	148	206	246	
<b>ZD</b>	36	52	70	45	75	95	58	100	120	70	124	142	86	134	178	116	174	214	
<b>ZE</b>	38	54	72	40	70	90	54	96	116	66	120	138	/	/	/	/	/	/	
<b>ZF</b>	26	42	60	28	58	78	38	80	100	48	102	120	60	108	152	80	138	178	
<b>ZG</b>	open	100	142	180	128	200	240	160	260	300	196	328	366	272	370	454	348	466	546
<b>ZH</b>	13,5	14	14	17	20	20	19,5	22,5	22,5	25	28	28	28	27	27	27	27	27	38
<b>Weight (g)</b>	280	350	430	600	800	950	1000	1500	1700	1700	2500	2800	2800	2900	3800	4700	5300	6850	7900
	20	40	60	30	60	80	40	80	100	50	100	120	70	120	160	100	160	200	200
	Stroke																		

**Operating criteria**

**Holding force**

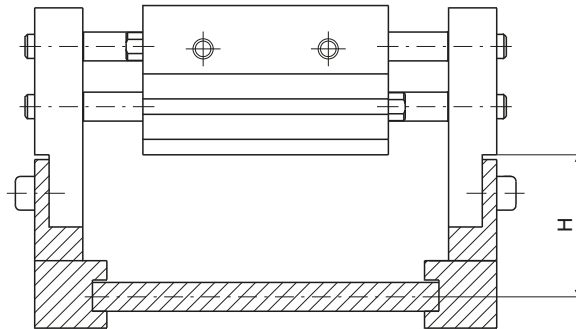
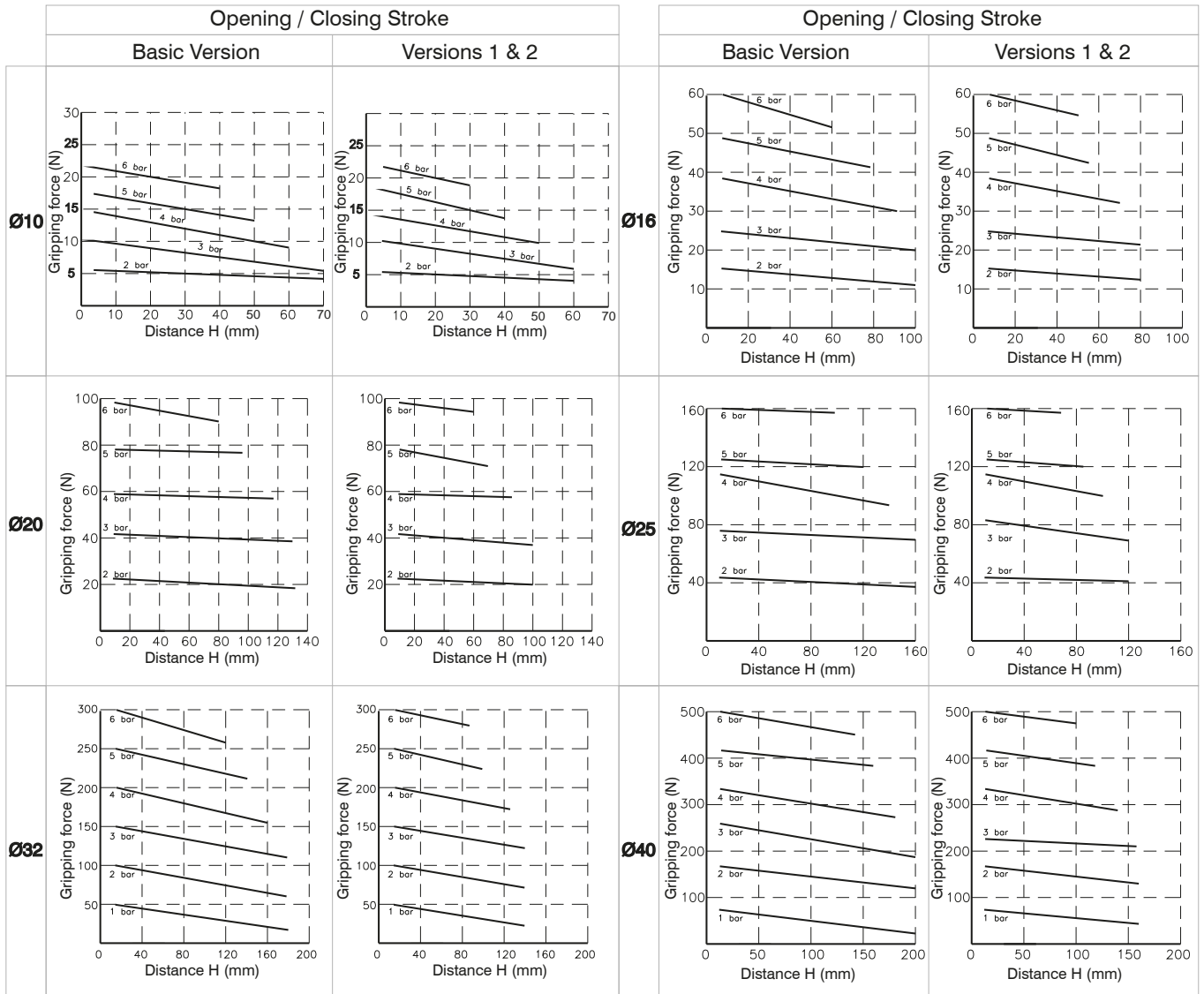

**PNEUMATIC ACTUATION**







Gripping force (N)

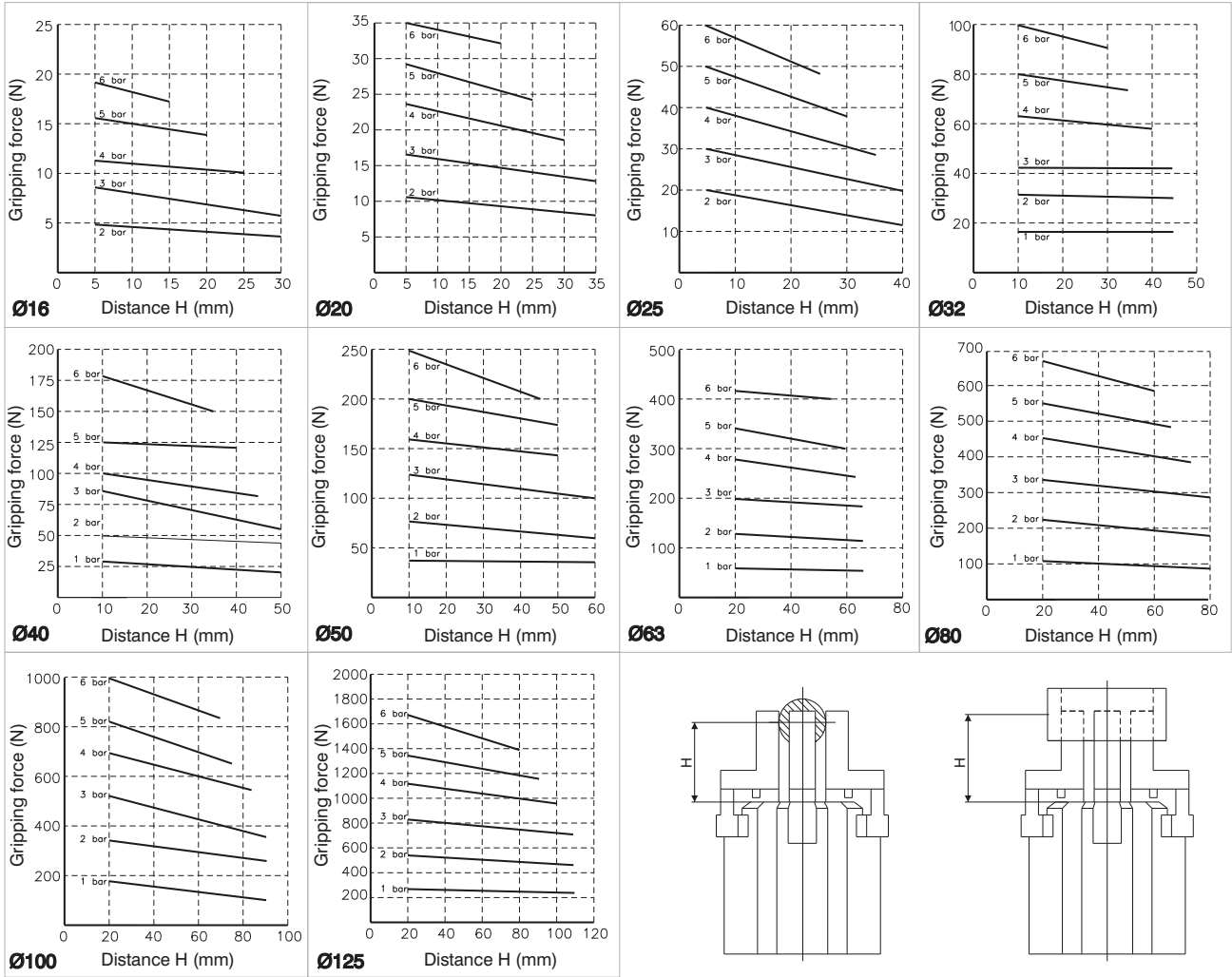

3

PNEUMATIC ACTUATION



## Series SA

### General

The limit switches, or magnetic sensors, must be mounted on cylinders with magnetic piston.

These, when hit by the magnetic field generated by the piston as it approaches, close the circuit sending an electrical signal to relay, solenoid valve or converse with the controlling electronic system of the machine. There are both ampulla Reed and Hall effect magnetic sensor available. The sensors are attached to the cylinder by a proper clamp, slot or adapter and may have an activation LED indicator.

Note: The magnetic sensors are according to the Directive **EMC 89/336/CEE** and following amendments.

### Instruction on how to use the sensors properly

Particular attention should be paid in order not to exceed the wide operating limits shown in the next pages. Besides, the 2 wires sensors have never to be connected to the mains if a load has not been yet connected in series. These are the only cares that, if not followed, may cause damages to the sensor. Besides, please consider that, while loading, the current absorbed by the sensors might be 50% higher that the rated one.

In case of direct current (DC) feeding, the polarity of the connection must be observed: the brown cable must be connected to the plus (+) and the blue one to the minus (-).

For all sensors, particular attention has to be paid to external factors (like, for example, nearby live cables, electromagnetic fields generated by electric motors, nearby metallic bodies, etc.) since they can affect the magnetic field generated by the magnet inside the piston and therefore causing malfunctions.

Electrical cable length must be kept below 10 meters in order to guarantee proper functioning.

If needed, 10 meters cable length can be exceeded; Pneumax suggests the use of an inductor or resistor in series to the load in order to reduce the capacitive behavior of the cable.

In this case, the customer is responsible for the selection of the inductor or resistor value. Pneumax assume no responsibility in case of malfunction.

When using a two wire Reed type sensor always ensure that the correct load is applied in series on any of the two wires.

When using a sensor fitted with the SNAP connector pay attention to the orientation of the connector (see fig. page 6.6) because by inverting the connection the circuit will not be damaged, but the LED will not turn on. In case two or more sensors need to be connected in series, pay attention to the voltage drop generated (around 3V for each sensor), and, in case, use the version designed for in series connection.

Hall effect sensors are longer lasting if compared to the Reed version since they do not include any moving mechanical part.



**Sensors with 2 wires cable (PUR Ø4,2 mm 2x0,34 mm<sup>2</sup>)**

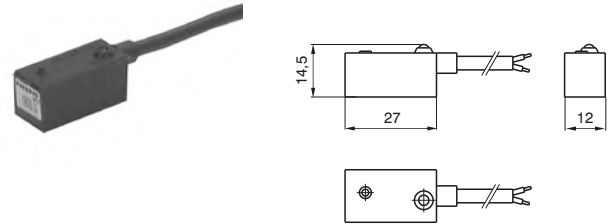
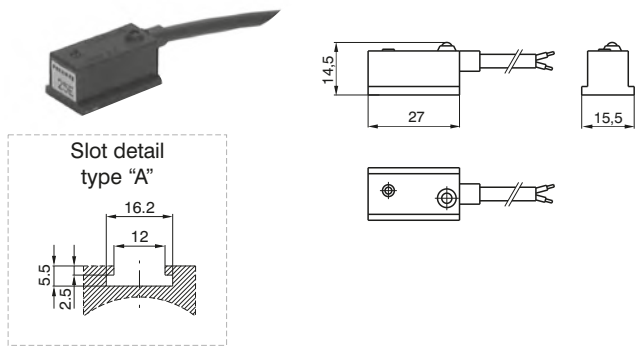

**Diagrams and connections**

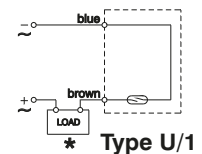
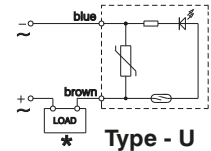
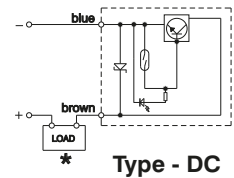
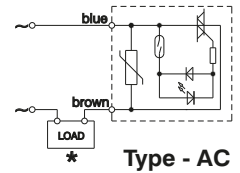

**Ordering code**

Cylinders and microbore cylinders	<b>1500.AC</b>	sensor for alternating current with led
	<b>1500.DC</b>	sensor for continuous current with led
	<b>1500. U</b>	universal sensor with led
	<b>1500.U/1</b>	universal sensor without led (REED ampulla only)
Rodless cylinders	<b>1600.AC</b>	sensor for alternating current with led
	<b>1600.DC</b>	sensor for continuous current with led
	<b>1600.U</b>	universal sensor with led
	<b>1600.U/1</b>	universal sensor without led (REED ampulla only)

Technical characteristics	A.C.	D.C.	U		U/1	
			a.c.	d.c.	a.c.	d.c.
Maximum permanent current	1,5A	1,2A	0,5A		0,3A	
Maximum current (pulses of 0,5 sec.)	6A	1,5A	1A		0,8A	
Voltage range	12 - 230V	12 - 30V	3 - 230V	12 - 48V	0 - 230V	0 - 48V
Maximum permanent power	375VA	32W	20VA	15W	10VA	8W
Working temperature	-20° C - 70°C					
Maximum voltage drop	3V max	2V max	3V max		0V	
Cable section	2x0,34 mm <sup>2</sup> Ø4,2 mm PUR					
Degree of protection	IP 65					
Connecting time	2 ms					
Disconnecting time	1 ms					
Average working period	10 <sup>7</sup> cycles					
Repetition of intervention point	± 0,1 mm					
Type of contact	N.O.					

★The load (LOAD) can be connected either to negative or positive pole.

These sensors can be used on cylinders series:

SERIES	DESCRIPTION	MOUNTED
<b>1200</b>	for microbore with threaded end covers and "TECNO-MIR" microbore	with clamps code 1260.Ø.F
	for microbore "MIR" with rolled end covers, cylinders from Ø16 to Ø32	with clamps code 1280.Ø.F
	for microbore "MIR-INOX" with rolled end covers	with clamps code 1280.Ø.FX
<b>1306 - 1307 - 1308</b>	for cylinders from Ø32 to Ø63	with brackets code 1306.A
	for cylinders from Ø80 to Ø125	with brackets code 1306.B
	for cylinders from Ø160 to Ø200	with brackets code 1306.C
<b>1315</b>	for cylinders Ø250 and Ø320 (ISO)	with brackets code 1306.D
	for cylinders Ø32 and Ø40	with brackets code 1320.A
<b>1319 - 1320</b>	for cylinders Ø50 and Ø63	with brackets code 1320.B
	for cylinders Ø80 and Ø100	with brackets code 1320.C
	for cylinders Ø125	with brackets code 1320.D
	for cylinders Ø160	with brackets code 1320.E
	for cylinders Ø200	with brackets code 1320.F
	for cylinders ECOLIGHT Ø32 and Ø40	with brackets code 1390.A
<b>1390 - 1391</b>	for cylinders ECOLIGHT Ø50 and Ø63	with brackets code 1390.B
	for cylinders ECOLIGHT Ø80 and Ø100	with brackets code 1390.C
	for cylinders ECOLIGHT Ø125 - Ø200	with brackets code 1390.D
	for cylinders ECOLIGHT Ø125 - Ø200	with brackets code 1390.D
<b>1500</b>	Compact cylinders "Europe" (from Ø32)	directly on groove
<b>1605</b>	Rodless cylinders	with brackets code 1600.A

**2 pin sensor for SNAP connector**



for cylinders and microbore

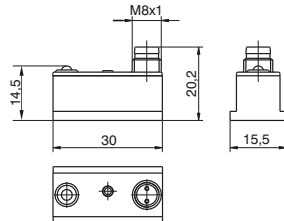
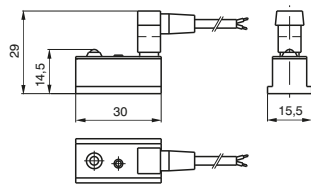
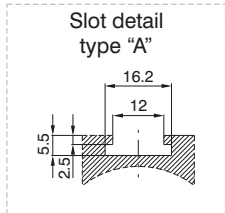

for rodless cylinders

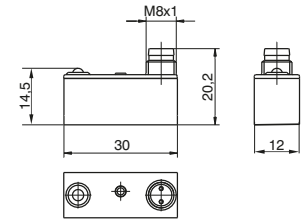
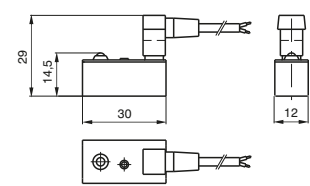

**Ordering code**

Cylinders and microbore	<b>RS.DC</b>	sensor for continuous current with led normally open N.O.
	<b>RS.UA</b>	universal sensor with led normally open N.O.
	<b>RS.UC</b>	universal sensor with led normally closed N.C.
	<b>RS.UA/1</b>	universal sensor without led N.O. (REED ampulla only)
Rodless cylinders	<b>SRS.DC</b>	sensor for continuous current with led normally open N.O.
	<b>SRS.UA</b>	universal sensor with led N.O.
	<b>SRS.UC</b>	universal sensor with led normally closed N.C.
	<b>SRS.UA/1</b>	universal sensor without led N.O.
Cable	<b>C1</b>	connector with 2.5 m. cable 2 wires (PVC Ø3,5 mm 2x 0,25mm <sup>2</sup> )
	<b>C2</b>	connector with 5 m. cable 2 wires (PVC Ø3,5 mm 2x 0,25mm <sup>2</sup> )
	<b>C3</b>	connector with 10 m. cable 2 wires (PVC Ø3,5 mm 2x 0,25mm <sup>2</sup> )

**2 pin sensor for SNAP connector + C1 cable 2 wires (PVC Ø3.5 mm 2x0.25 mm<sup>2</sup>)**

Cylinders and microbore	<b>RS.DCC1</b>	sensor for DC current N.O. with LED and 2.5 m. cable
	<b>RS.UAC1</b>	universal sensor with led N.O. with connector and 2.5 m. cable
	<b>RS.UCC1</b>	universal sensor with led N.C. with connector and 2.5 m. cable
	<b>RS.UAC1/1</b>	universal sensor without led N.O. with connector and 2.5 m. cable (REED ampulla only)
Rodless cylinders	<b>SRS.DCC1</b>	sensor for continuous current with led normally closed N.O. with connector and 2.5 m. cable
	<b>SRS.UAC1</b>	universal sensor with led N.O. with connector and 2.5 m. cable
	<b>SRS.UCC1</b>	universal sensor with led N.C. with connector and 2.5 m. cable
	<b>SRS.UAC1/1</b>	universal sensor without led N.O. with connector and 2.5 m. cable (REED ampulla only)

**2 pin sensor with M8 connettor**

Cylinders and microbore	<b>RS8.DC</b>	sensor for DC current N.O. with LED and M8 plug
	<b>RS8.UA</b>	universal sensor N.O. with LED and M8 plug
	<b>RS8.UC</b>	universal sensor N.C. with LED and M8 plug
Rodless cylinders	<b>SRS8.DC</b>	sensor for DC current N.O. with LED and M8 plug
	<b>SRS8.UA</b>	universal sensor N.O. with LED and M8 plug
	<b>SRS8.UC</b>	universal sensor N.C. with LED and M8 plug
Cable	<b>MCH1</b>	cable 3 wires l=2.5m with M8 connector three wires (PUR Ø2.6 mm 3x 0.15 mm <sup>2</sup> )
	<b>MCH2</b>	cable 3 wires l=5m with M8 connector three wires (PUR Ø2.6 mm 3x 0.15 mm <sup>2</sup> )
	<b>MCH3</b>	cable 3 wires l=10m with M8 connector three wires (PUR Ø2.6 mm 3x 0.15 mm <sup>2</sup> )



► **3 pin sensor for SNAP connector with 2 wires according to IEC 947 norms**

Cylinders and microbore	<b>RS.DCNO</b>	sensor for continuous current with led normally open N.O., according to standard IEC 947
	<b>RS.UANO</b>	universal sensor with led normally open N.O., according to standard IEC 947
Cable	<b>C1NO</b>	connector with 2.5 m. cable, according to standard IEC 947 (PVC Ø3.5 mm 2x0.25 mm <sup>2</sup> )
	<b>C2NO</b>	connector with 5 m. cable, according to standard IEC 947 (PVC Ø3.5 mm 2x0.25 mm <sup>2</sup> )
	<b>C3NO</b>	connector with 10 m. cable, according to standard IEC 947 (PVC Ø3.5 mm 2x0.25 mm <sup>2</sup> )

► **3 pin sensors for in series assembling with SNAP connector**

Cylinders and microbore Rodless cylinders	<b>RS.UA/1L</b>	universal sensor with led normally open N.O., for series assembly (3 wires)
	<b>SRS.UA/1L</b>	universal sensor with led N.O., for series assembly (3 wires)
Cable	<b>CH1</b>	connector with 2.5 m. cable 3 wires (PVC Ø3.5 mm 3x0.25 mm <sup>2</sup> )
	<b>CH2</b>	connector with 5 m. cable 3 wires (PVC Ø3.5 mm 3x0.25 mm <sup>2</sup> )
	<b>CH3</b>	connector with 10 m. cable 3 wires (PVC Ø3.5 mm 3x0.25 mm <sup>2</sup> )

► **3 pin sensors for in series assembling with SNAP conn. + CH1 cable 3 wires (PVC ø3.5mm 3x0.25 mm<sup>2</sup>)**

Cylinders and microbore	<b>RS.UACH1/1L</b>	universal sensor with led N.O. with connector and 2.5 m. cable, for series mounting (3 wires)
Rodless cylinders	<b>SRS.UACH1/1L</b>	universal sensor with led N.O. with connector and 2.5 m. cable, for series assembly (3 wires)

► **3 pin sensors for in series assembling with M8 connector**

Cylinders and microbore Rodless cylinders	<b>RS8.UA/1L</b>	universal sensor N.O. with LED for in series assembling (3wires) and M8 plug
	<b>SRS8.UA/1L</b>	universal sensor N.O. with LED for in series assembling (3wires) and M8 plug
Cable	<b>MCH1</b>	M8 connector with 2.5 m. cable 3 wires (PUR Ø2.6 mm 3x 0.15 mm <sup>2</sup> )
	<b>MCH2</b>	M8 connector with 5 m. cable 3 wires (PUR Ø2.6 mm 3x 0.15 mm <sup>2</sup> )
	<b>MCH3</b>	M8 connector with 10 m. cable 3 wires (PUR Ø2.6 mm 3x 0.15 mm <sup>2</sup> )

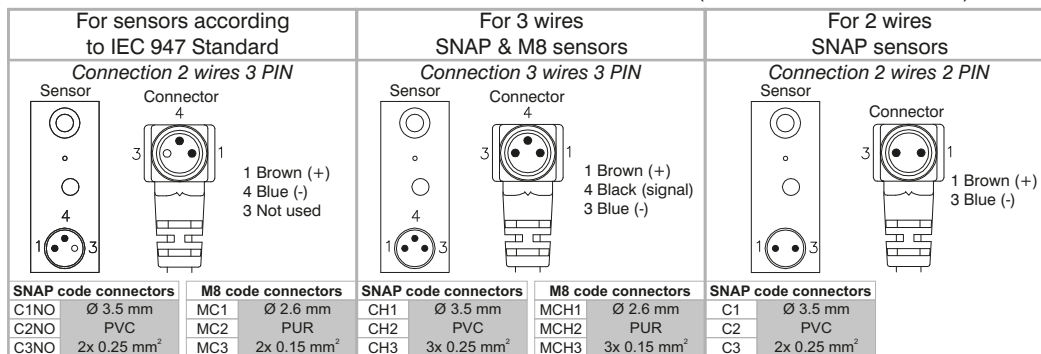

Technical characteristics	DC	UA				UA/1L		UA/1	
		a.c.		d.c.		a.c.	d.c.	a.c.	d.c.
Type of contact	N.O.	N.O.	N.C.	N.O.	N.C.	N.O.		N.O.	
Maximum permanent current	1.2A	0.5A	0.3A	0.5A	0.3A	0.5A		0.5A	
Maximum current (pulses of 0.5 sec.)	1.5A	1A	0.8A	1A	0.8A	1A		1A	
Voltage range	12 - 30V	3 - 250V	3 - 110V	12 - 48V		24V		0 - 250V	0 - 48V
Maximum permanent power	32W	20VA	10VA	15W	8W	20VA	15W	10VA	8W
Working temperature		-20°C - 70°C							
Maximum voltage drop	2V	<3V				0V			
Cables number		2				3		2	
Degree of protection		IP65							
Connecting time		2 ms							
Disconnecting time		1 ms							
Average working period		10 <sup>7</sup> cycles							
Repetition of intervention point		±0.1 mm							

Diagrams and connections

Type - UA

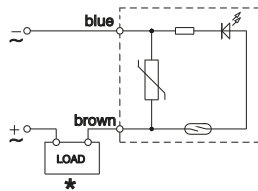

Type UA/1

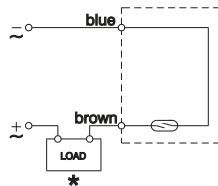

Type - UA/1L

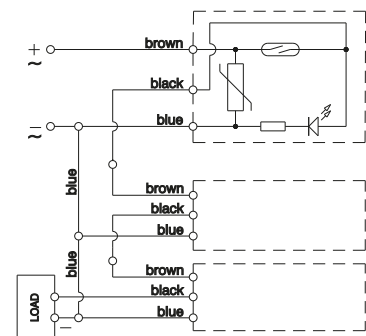

Type - DC

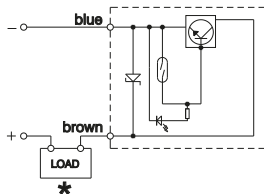

Type - DCNO

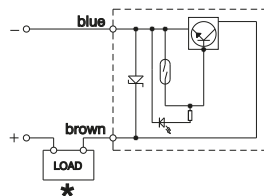

Type - UC

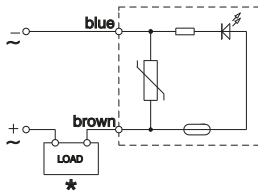

\*The load (LOAD) can be connected either to negative or positive pole.

These sensors can be used on cylinders series:

SERIES	DESCRIPTION	MOUNTED
1200	for microbore with threaded end covers and "TECNO-MIR" microbore	with clamps code 1260.Ø.F
	for microbore "MIR" with rolled end covers, cylinders from Ø16 to Ø32	with clamps code 1280.Ø.F
1306 - 1307 - 1308	for microbore "MIR-INOX" with rolled end covers	with clamps code 1280.Ø.FX
	for cylinders from Ø32 to Ø63	with brackets code 1306.A
1315	for cylinders from Ø80 to Ø125	with brackets code 1306.B
	for cylinders from Ø160 to Ø200	with brackets code 1306.C
1319 - 1320	for cylinders Ø250 and Ø320 (ISO)	with brackets code 1306.D
	for cylinders Ø32 and Ø40	with brackets code 1320.A
1390 - 1391	for cylinders Ø50 and Ø63	with brackets code 1320.B
	for cylinders Ø80 and Ø100	with brackets code 1320.C
	for cylinders Ø125	with brackets code 1320.D
	for cylinders Ø160	with brackets code 1320.E
	for cylinders Ø200	with brackets code 1320.F
	for cylinders ECOLIGHT Ø32 and Ø40	with brackets code 1390.A
1500	for cylinders ECOLIGHT Ø50 and Ø63	with brackets code 1390.B
	for cylinders ECOLIGHT Ø80 and Ø100	with brackets code 1390.C
1605	for cylinders ECOLIGHT Ø125 - Ø200	with brackets code 1390.D
	Compact cylinders "Europe" (from Ø32)	directly on groove
	Rodless cylinders	with brackets code 1600.A



► Sensors with 3 wires cable PUR  $\varnothing$  4.2 mm 3x0.34mm<sup>2</sup>)

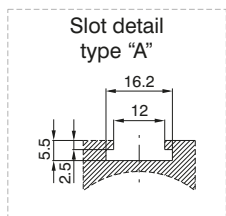
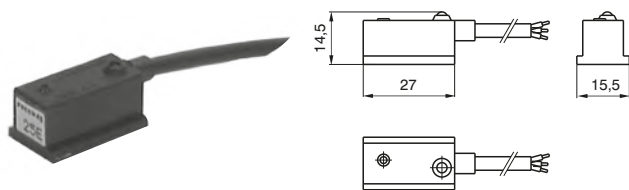

for cylinders and microbore

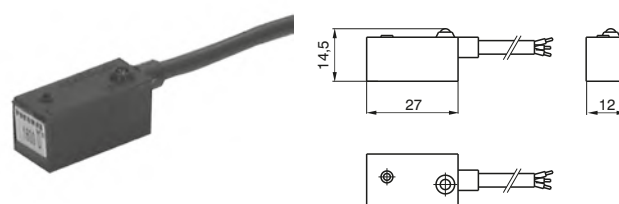

for rodless cylinders

Ordering code

Cylinders and microbore	<b>1500.HAP</b>	PNP sensor Hall effect with led, normally open N.O.
	<b>1500.HAN</b>	NPN sensor Hall effect with led, normally open N.O.
Rodless cylinders	<b>1600.HAP</b>	PNP sensor Hall effect with led, normally open N.O.
	<b>1600.HAN</b>	NPN sensor Hall effect with led, normally open N.O.

Technical characteristics

Maximum permanent current	0.5A
Voltage range	10 - 30V DC
Power (inductive load)	10W
Maximum voltage drop	2V
Working temperature	-20°C - 70°C
Cable section	PUR 4.2mm 3x0.34 mm <sup>2</sup>
Degree of protection	IP 65
Connecting time	0.8 $\mu$ s
Disconnecting time	0.3 $\mu$ s
Average working period	10 <sup>9</sup> cycles
Repetition of intervention point	$\pm$ 0.1 mm
Type of contact	N.O.

Diagrams and connections

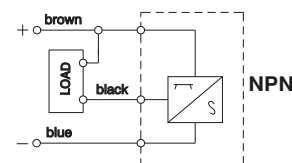
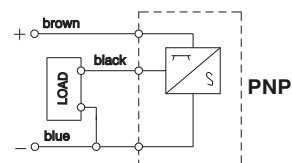

These sensors can be used on cylinders series:

SERIES	DESCRIPTION	MOUNTED
<b>1200</b>	for microbore with threaded end covers and "TECNO-MIR" microbore	with clamps code 1260.Ø.F
	for microbore "MIR" with rolled end covers, cylinders from Ø16 to Ø32	with clamps code 1280.Ø.F
	for microbore "MIR-INOX" with rolled end covers	with clamps code 1280.Ø.FX
<b>1306 - 1307 - 1308</b>	for cylinders from Ø32 to Ø63	with brackets code 1306.A
	for cylinders from Ø80 to Ø125	with brackets code 1306.B
<b>1315</b>	for cylinders from Ø160 to Ø200	with brackets code 1306.C
	for cylinders Ø250 and Ø320 (ISO)	with brackets code 1306.D
<b>1319 - 1320</b>	for cylinders Ø32 and Ø40	with brackets code 1320.A
	for cylinders Ø50 and Ø63	with brackets code 1320.B
	for cylinders Ø80 and Ø100	with brackets code 1320.C
	for cylinders Ø125	with brackets code 1320.D
	for cylinders Ø160	with brackets code 1320.E
	for cylinders Ø200	with brackets code 1320.F
<b>1390 - 1391</b>	for cylinders ECOLIGHT Ø32 and Ø40	with brackets code 1390.A
	for cylinders ECOLIGHT Ø50 and Ø63	with brackets code 1390.B
	for cylinders ECOLIGHT Ø80 and Ø100	with brackets code 1390.C
	for cylinders ECOLIGHT Ø125 - Ø200	with brackets code 1390.D
<b>1500</b>	Compact cylinders "Europe" (from Ø32)	directly on groove
<b>1605</b>	Rodless cylinders	with brackets code 1600.A

**3 PIN sensor for SNAP connector**

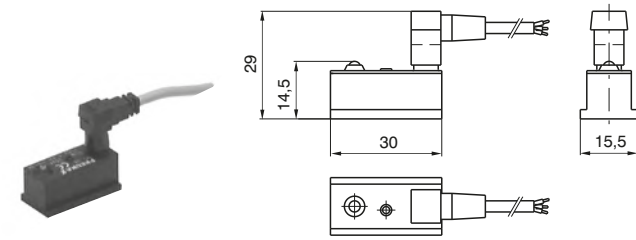

for cylinders and microbore

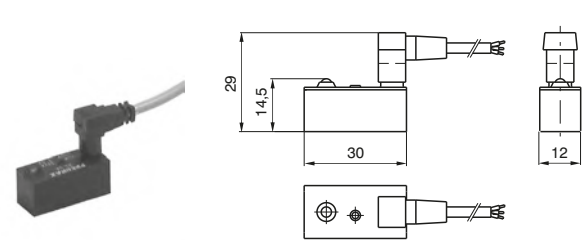
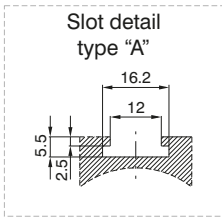

for rodless cylinders

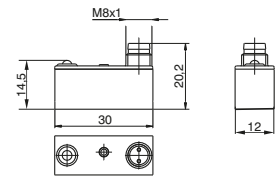
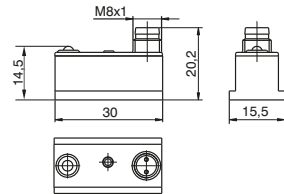

**Ordering code**

Cylinders and microcylinders	<b>HS.PA</b>	PNP sensor Hall effect with led, normally open N.O.
Rodless cylinders	<b>SHS.PA</b>	PNP sensor Hall effect with led, normally open N.O.
Cable	<b>CH1</b>	connector with 2.5 m. cable 3 wires (PVC Ø3.5 mm 3x0.25 mm <sup>2</sup> )
	<b>CH2</b>	connector with 5 m. cable 3 wires (PVC Ø3.5 mm 3x0.25 mm <sup>2</sup> )
	<b>CH3</b>	connector with 10 m. cable 3 wires (PVC Ø3.5 mm 3x0.25 mm <sup>2</sup> )

**3 PIN sensor for SNAP connector + CH1 cable 3 wires (PVC ø3.5 mm 3x0.25 mm<sup>2</sup>)**

Cylinders and microbore	<b>HS.PAC1</b>	PNP sensor Hall effect N.O. with led, with connector and 2.5 m. cable
Rodless cylinders	<b>SHS.PAC1</b>	PNP sensor Hall effect N.O. with led, with connector and 2.5 m. cable

**3 PIN sensor for M8 connector**

Cylinders and microbore	<b>HS8.NA</b>	NPN Hall effect sensor N.O. with LED and M8 plug
	<b>HS8.PA</b>	PNP Hall effect sensor N.O. with LED and M8 plug
Rodless cylinders	<b>SHS8.NA</b>	NPN Hall effect sensor N.O. with LED and M8 plug
	<b>SHS8.PA</b>	PNP Hall effect sensor N.O. with LED and M8 plug
Cable	<b>MCH1</b>	M8 connector with cable 2.5 m. 3 wires (PUR Ø2.6 mm 3x0.15mm <sup>2</sup> )
	<b>MCH2</b>	M8 connector with cable 5 m. 3 wires (PUR Ø2.6 mm 3x0.15mm <sup>2</sup> )
	<b>MCH3</b>	M8 connector with cable 10 m. 3 wires (PUR Ø2.6 mm 3x0.15mm <sup>2</sup> )

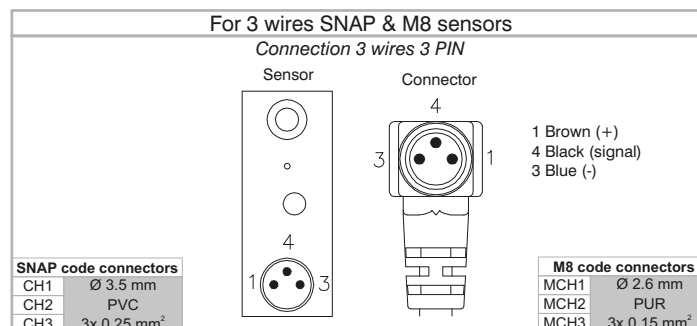





**Technical characteristic**

Maximum permanent current	0,25A
Voltage range	6 - 30V DC
Power (inductive load)	6W
Maximum Voltage drop	2V
Working temperature	-20°C - 70°C
Cables number	3
Degree of protection	IP 65
Connecting time	0,8 ms
Disconnecting time	0,3 ms
Average working period	10 <sup>8</sup> cycles
Repetition of intervention point	± 0,1 mm
Contact normally open	N.O.

**Diagrams and connections**

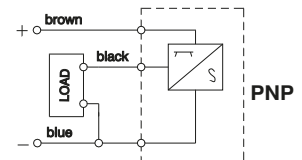
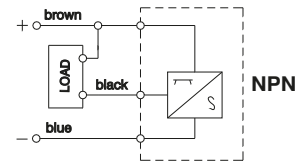

**These sensors can be used on cylinders series:**

SERIES	DESCRIPTION	MOUNTED
<b>1200</b>	for microbore with threaded end covers and "TECNO-MIR" microbore for microbore "MIR" with rolled end covers, cylinders from Ø16 to Ø32 for microbore "MIR-INOX" with rolled end covers	with clamps code 1260.Ø.F with clamps code 1280.Ø.F with clamps code 1280.Ø.FX
<b>1306 - 1307 - 1308</b>	for cylinders from Ø32 to Ø63 for cylinders from Ø80 to Ø125 for cylinders from Ø160 to Ø200	with brackets code 1306.A with brackets code 1306.B with brackets code 1306.C with brackets code 1306.D
<b>1315</b>	for cylinders Ø250 and Ø320 (ISO)	with brackets code 1320.A with brackets code 1320.B with brackets code 1320.C with brackets code 1320.D with brackets code 1320.E with brackets code 1320.F
<b>1319 - 1320</b>	for cylinders Ø32 and Ø40 for cylinders Ø50 and Ø63 for cylinders Ø80 and Ø100 for cylinders Ø125 for cylinders Ø160 for cylinders Ø200	with brackets code 1390.A with brackets code 1390.B with brackets code 1390.C with brackets code 1390.D
<b>1390 - 1391</b>	for cylinders ECOLIGHT Ø32 and Ø40 for cylinders ECOLIGHT Ø50 and Ø63 for cylinders ECOLIGHT Ø80 and Ø100 for cylinders ECOLIGHT Ø125 - Ø200	directly on groove with brackets code 1600.A
<b>1500</b>	Compact cylinders "Europe" (from Ø32)	
<b>1605</b>	Rodless cylinders	



## Series SR - SU - SQ - ST

### General

The limit switches, or magnetic sensors, must be mounted on cylinders with magnetic piston.

These, when hit by the magnetic field generated by the piston as it approaches, close the circuit sending an electrical signal to relay, solenoid valve or converse with the controlling electronic system of the machine. There are both ampulla Reed and Hall effect magnetic sensor available. The sensors are attached to the cylinder by a proper clamp, slot or adapter and may have an activation LED indicator.

Note: The magnetic sensors are according to the Directive **EMC 89/336/CEE** and following amendments.

### Instruction on how to use the sensors properly

Particular attention should be paid in order not to exceed the wide operating limits shown in the next pages. Besides, the 2 wires sensors have never to be connected to the mains if a load has not been yet connected in series. These are the only cares that, if not followed, may cause damages to the sensor. Besides, please consider that, while loading, the current absorbed by the sensors might be 50% higher that the rated one.

In case of direct current (DC) feeding, the polarity of the connection must be observed: the brown cable must be connected to the plus (+) and the blue one to the minus (-).

For all sensors, particular attention has to be paid to external factors (like, for example, nearby live cables, electromagnetic fields generated by electric motors, nearby metallic bodies, etc.) since they can affect the magnetic field generated by the magnet inside the piston and therefore causing malfunctions.

Electrical cable length must be kept below 10 meters in order to guarantee proper functioning.

If needed, 10 meters cable length can be exceeded; Pneumax suggests the use of an inductor or resistor in series to the load in order to reduce the capacitive behavior of the cable.

In this case, the customer is responsible for the selection of the inductor or resistor value. Pneumax assume no responsibility in case of malfunction.

When using a two wire Reed type sensor always ensure that the correct load is applied in series on any of the two wires.

In case two or more sensors need to be connected in series, pay attention to the voltage drop generated (around 3V for each sensor), and, in case, use the version designed for in series connection.

Hall effect sensors are longer lasting if compared to the Reed version since they do not include any moving mechanical part.



► Sensor with 2.5 m. cable

Weight g 27

Sensor with cable and M8 connector

Weight g 15

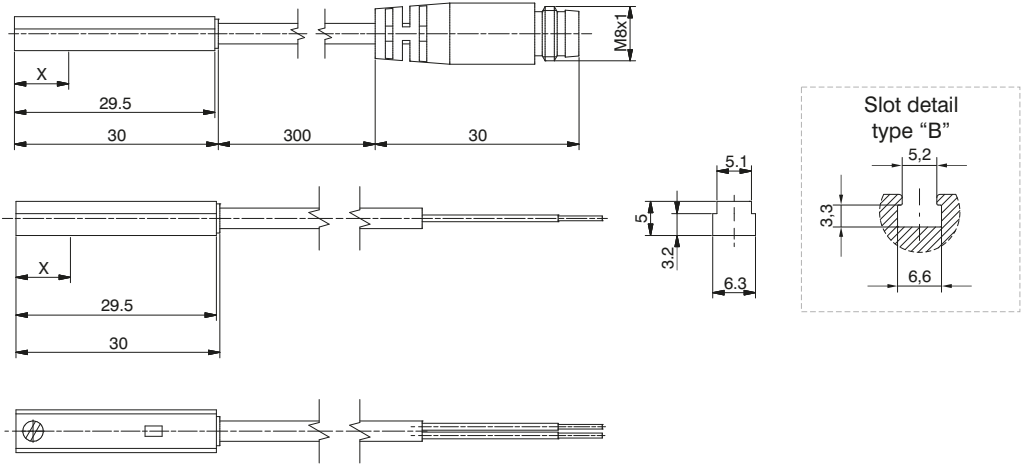

Ordering code

► Ampulla Reed sensors, with led, Universal, N.O. (Normally open)

Code	Description	X=point of commutation
1580.U	(2 wires) cable 2.5 mt.	15 mm
MRS.U	(2 wires) cable 300 mm, M8 connector (use MC1 or MC2 connectors)	15 mm
1580.UAP	PNP (3 wires) cable 2.5 mt.	15 mm
MRS.UAP	PNP (3 wires) cable 300 mm, M8 connector (use MCH1 or MCH2 connectors)	15 mm

► Hall effect sensors, with led, DC, N.O. (Normally open)

Code	Description	X=point of commutation
1580.HAP	PNP (3 wires) cable 2.5 mt.	8 mm
1580.HAN	NPN (3 wires) cable 2.5 mt.	8 mm
MHS.P	PNP (3 wires) cable 300 mm, M8 connector (use MCH1 or MCH2 connectors)	8 mm

Diagrams and connections

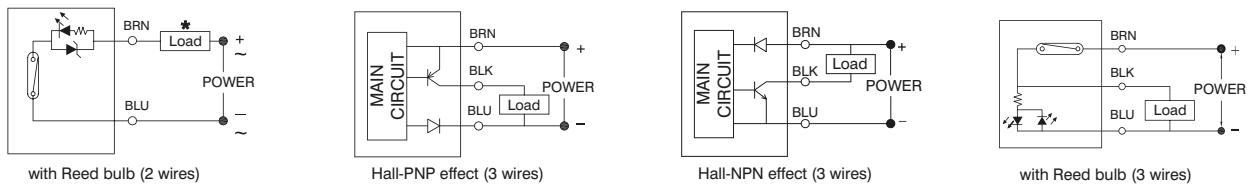

\* The load (LOAD) can be connected either to negative or positive pole

Technical characteristics	1580.U	MRS.U	1580.UAP	MRS.UAP	1580.HAP	1580.HAN	MHS.P
Type of contact	N.O.						
Output type	PNP			NPN		PNP	
Maximum current	100mA						
Maximum permanent power	14 VA - 10 W		4 VA - 3 W		3 W		
Voltage range	5 - 230V DC/AC	5 - 30V DC/AC	10 - 30 V DC/AC		10 - 30 V DC		
Working temperature	-10°C - +70°C						
Maximum voltage drop	3.5 V		0V **		2 V		
Cable section (mm <sup>2</sup> )	2 x 0.14 Ø3.3mm PUR	2 x 0.14 Ø3.3mm PUR	3 x 0.14 Ø3.3 mm PUR		3 x 0.14 Ø3.3 mm PUR		
Degree of protection	IP 67						

\*\* Even if one sensor generates a voltage drop very close to 0 Volts, we suggest to connect no more than 30 sensors in series.

Cable ordering code

- MC1 cable 2 wires l=2.5m with M8 connector
- MC2 cable 2 wires l=5m with M8 connector
- MC3 cable 2 wires l=10m with M8 connector

- MCH1 cable 3 wires l=2.5m with M8 connector
- MCH2 cable 3 wires l=5m with M8 connector
- MCH3 cable 3 wires l=10m with M8 connector

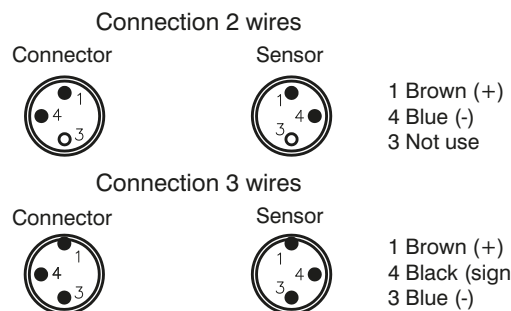

► Sensor with 2.5 m. cable

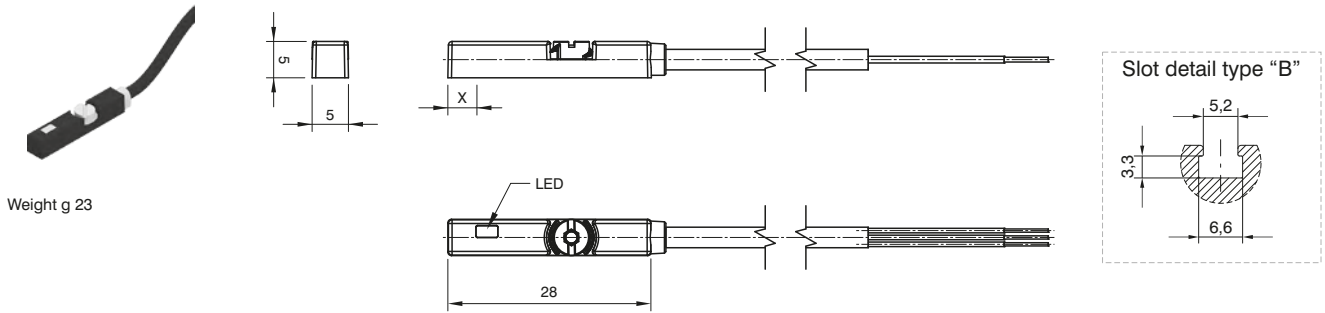

Weight g 23

Ordering code

Hall effect sensors, with led, DC, N.O. (Normally open)		X= point of commutation
1595.HAP	PNP (3 wires) cable 2.5 mt.	2.3 mm

Diagrams and connections

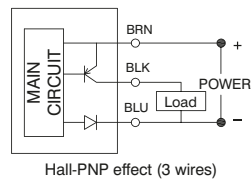

Technical characteristics	1595.HAP
Type of contact	N.O.
Output type	PNP
Maximum current	100 mA
Maximum permanent power	3W
Voltage range	10 - 28 VDC
Working temperature	-10 - +70°C
Maximum voltage drop	1,5V
Cable section (mm <sup>2</sup> )	3 x 0,14 Ø2.8 mm PUR
Degree of protection	IP67



► Sensor with 2,5 m cable



Weight g 27

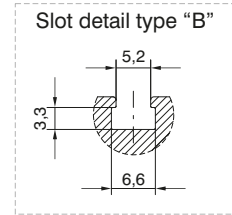
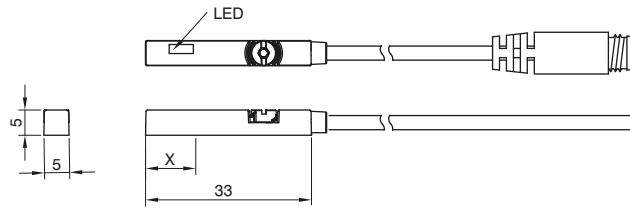

Sensor with cable and M8 connector



Weight g 15

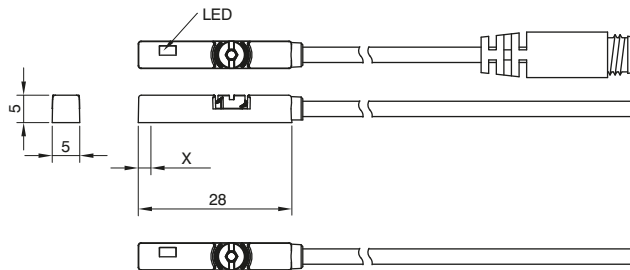

Ordering code

► Ampulla Reed sensors, with led, Universal, N.O. (Normally open)

		X=point of commutation
<b>1590.U</b>	(2 wires) cable 2.5 mt.	10 mm
<b>LRS.U</b>	(2 wires) cable 300 mm, M8 connector (use MC1 or MC2 connectors)	10 mm
<b>1590.UAP</b>	PNP (3 wires) cable 2.5 mt.	10 mm
<b>LRS.UAP</b>	PNP (3 wires) cable 300 mm, M8 connector (use MCH1 or MCH2 connectors)	10 mm

► Hall effect sensors, with led, DC, N.O. (Normally open)

		X=point of commutation
<b>1590.HAP</b>	PNP (3 wires) cable 2.5 mt.	2,3 mm
<b>LHS.P</b>	PNP (3 wires) cable 300 mm, M8 connector (use MCH1 or MCH2 connectors)	2,3 mm

Diagrams and connections

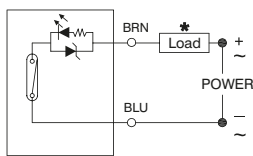

with Reed bulb (2 wires)

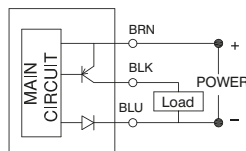

Hall-PNP effect (3 wires)

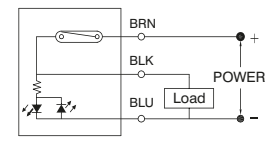

with Reed bulb (3 wires)

\* The load (LOAD) can be connected either to negative or positive pole

Technical characteristics	1590.U	LRS.U	1590.UAP	LRS.UAP	1590.HAP	LHS.P
Type of contact	N.O.					
Maximum current	100mA		500mA		200mA	
Maximum permanent power	14 VA - 10 W		14 VA - 10 W		6 W	
Voltage range	5 - 30V DC/AC		10 - 30 V DC/AC		10 - 30 V DC	
Working temperature			-10°C - +70°C			
Maximum voltage drop	3 V		0V **		1.5 V	
Cable section (mm <sup>2</sup> )	2 x 0.14 Ø3 mm PUR				3 x 0.14 Ø3 mm PUR	
Degree of protection	IP 67					

\*\* Even if one sensor generates a voltage drop very close to 0 Volts, we suggest to connect no more than 30 sensors in series.

Cable ordering code

- MC1** cable 2 wires l=2.5m with M8 connector
- MC2** cable 2 wires l=5m with M8 connector
- MC3** cable 2 wires l=10m with M8 connector

Connection 2 wires

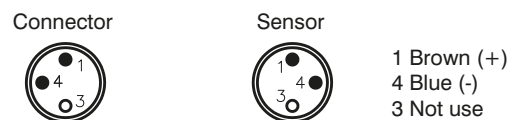

Connection 3 wires

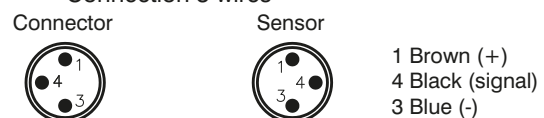

- MCH1** cable 3 wires l=2.5m with M8 connector
- MCH2** cable 3 wires l=5m with M8 connector
- MCH3** cable 3 wires l=10m with M8 connector

**Sensor with 2.5 m. cable**



Weight g 22

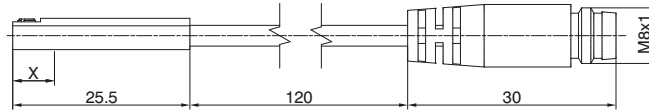

**Sensor with cable and M8 connector**



Weight g 10

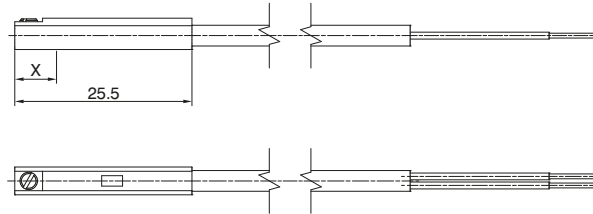

Slot detail type "C"

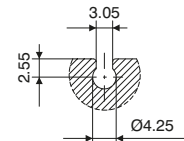

Slot detail type "D"

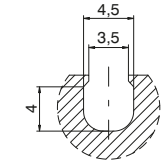

**Ordering code**

**Ampulla Reed sensors, with led, Universal, N.O. (Normally open)**

Ordering code	Description	X=point of commutation
1581.U	(2 wires) cable 2.5 mt.	10 mm
TRS.U	(2 wires) cable 100 mm, M8 connector (use MC1 or MC2 connectors)	10 mm

**Hall effect sensors, with led, DC, N.O. (Normally open)**

Ordering code	Description	X=point of commutation
1581.HAP	PNP (3 wires) cable 2.5 mt.	7,5 mm
THS.P	PNP (3 wires) cable 100 mm, M8 connector (use MCH1 or MCH2 connectors)	7,5 mm

**Diagrams and connections**

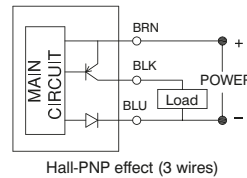
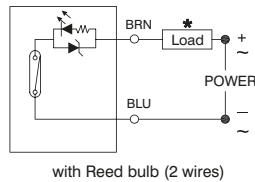

\* The load (LOAD) can be connected either to negative or positive pole

Technical characteristics	1581.U	TRS.U	1581.HAP	THS.P
Type of contact	N.O.			
Maximum current	50mA			
Maximum permanent power	8 VA - 1,5 W		1,5 W	
Voltage range	5 - 30V DC/AC		10 - 30 V DC	
Working temperature	-10°C - +70°C			
Maximum voltage drop	3,5 V		1 V	
Cable section (mm <sup>2</sup> )	2 x 0,14 Ø2,8 mm PUR		3 x 0,14 Ø2,8 mm PUR	
Degree of protection	IP 67			

**Cable ordering code**

**Connection 2 wires**

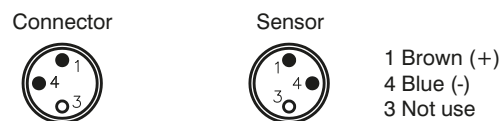

**Connection 3 wires**

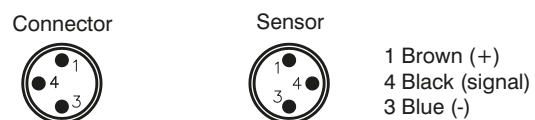

- MC1** cable 2 wires l=2.5m with M8 connector
- MC2** cable 2 wires l=5m with M8 connector
- MC3** cable 2 wires l=10m with M8 connector

- MCH1** cable 3 wires l=2.5m with M8 connector
- MCH2** cable 3 wires l=5m with M8 connector
- MCH3** cable 3 wires l=10m with M8 connector



► Sensor with cable



Weight g 22

► Sensor with cable and M8 connector



Weight g 10

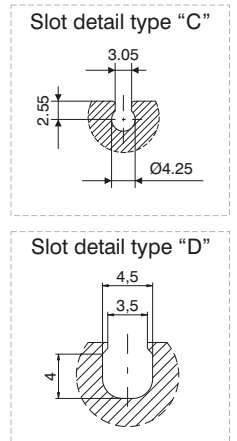
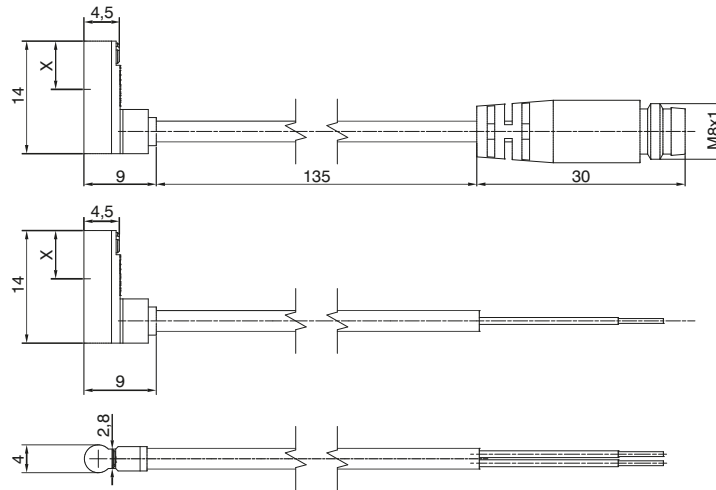

Ordering code

► Ampulla Reed sensors, with led, DC, N.O. (Normally open)

		X=point of commutation
1583.DC	(2 wires) cable 2 mt.	6 mm

► Hall effect sensors, with led, N.O. (Normally open)

		X=point of commutation
1583.HAP	PNP (3 wires) cable 3 mt.	6 mm
THR.P	PNP (3 wires) cable 100 mm, M8 connector (use MCH1 or MCH2 connectors)	6 mm

Diagrams and connections

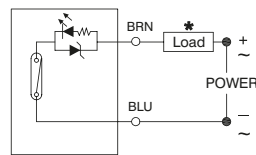

with Reed bulb (2 wires)

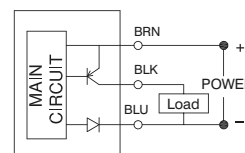

Hall-PNP effect (3 wires)

\* The load (LOAD) can be connected either to negative or positive pole

TECHNICAL CHARACTERISTICS	1583.DC	1583.HAP	THR.P
Type of contact		N.O.	
Maximum current	20mA		50mA
Maximum permanent power	0,6 W		1,5 W
Voltage range	10 - 28V DC		4,5 - 28 V DC
Working temperature		-10°C - +70°C	
Maximum voltage drop	3,5 V		0,5 V
Cable	Ø2,6 mm PVC - 2 m		Ø2,6 mm PVC - 3 m
Degree of protection		IP 67	

Cable ordering code

- MCH1 cable 3 wires l=2.5m with M8 connector
- MCH2 cable 3 wires l=5m with M8 connector

Connection 3 wires

Connector



Sensor



- 1 Brown (+)
- 4 Black (signal)
- 3 Blue (-)

3

PNEUMATIC ACTUATION



Rectangular section version (for sensor slot type "B")

SERIES	DESCRIPTION	MOUNTED
1200	Microbore with threaded end covers and "TECNO-MIR" microbore "MIR" with rolled end covers Microbore "MIR-INOX" with rolled end covers for cylinders Ø32 - Ø40	with clamps code <b>1260.Ø.FS</b> with clamps code <b>1280.Ø.FS</b> with clamps code <b>1280.Ø.FSX</b> with brackets code <b>1320.AS</b>
1319 - 1320 1325 - 1345 1330 - 1332 1348 - 1349	for cylinders Ø50 ÷ Ø63	with brackets code <b>1320.BS</b>
	for cylinders Ø80 ÷ Ø100	with brackets code <b>1320.CS</b>
	for cylinders Ø125	with brackets code <b>1320.DSC</b>
	for cylinders Ø160	with brackets code <b>1320.ESC</b>
	for cylinders Ø200	with brackets code <b>1320.FSC</b>
1386-87 / 1396-97	Cylinders according to standard ISO 15552 ECOPLUS	directly on groove
	Cylinders according to standard ISO 15552 ECOLIGHT	
1390 - 1391	<b>Warning:</b> To use only into the lateral slot, from Ø32 to Ø63 cylinders. (do not use into the 2 slots positioned on the side of feeding connection)	directly on groove
1370÷1373	Cylinders ECOFLAT	directly on groove
	Short stroke compact cylinders	with adapter code <b>1380.01F</b>
1500	Compact cylinders "Europe"	from Ø12 to Ø25: directly on groove from Ø32 to Ø50: directly on groove or with adapter <b>1380.01F</b> from Ø63 to Ø100: with adapter cod. <b>1380.01F</b>
	Compact cylinder according to standard ISO 21287 ECOMPACT	directly on groove
1605	Rodless cylinders	with adapter code <b>1600.B</b>
6100	Guided compact cylinder (Ø20 - Ø63)	
6101	Heavy duty guided shortstroke cylinder	
6200	Twin rod slides units	
6210	Twin through rod slides units	
6301	Pneumatic grippers, angular standard version	
6303	180° angular gripper rack & pinion style	
6310	Parallel style pneumatic grippers standard version (Ø10 - Ø25)	
6311	Parallel style pneumatic grippers wide opening	
6312	3 finger parallel style pneumatic grippers (Ø32 - Ø125)	directly on groove



Square section version (for sensor slot type "B")

SERIES	DESCRIPTION	MOUNTED
1200	Microbore with threaded end covers and "TECNO-MIR" microbore "MIR" with rolled end covers Microbore "MIR-INOX" with rolled end covers for cylinders Ø32 - Ø40	with clamps code <b>1260.Ø.FS</b> with clamps code <b>1280.Ø.FS</b> with clamps code <b>1280.Ø.FSX</b> with brackets code 1320.ASC
1319 - 1320 1325 - 1345 1330 - 1332 1348 - 1349	for cylinders Ø50 - Ø63	with brackets code 1320.BSC
	for cylinders Ø80 - Ø100	with brackets code 1320.CSC
	for cylinders Ø125	with brackets code 1320.DSC
	for cylinders Ø160	with brackets code 1320.ESC
	for cylinders Ø200	with brackets code 1320.FSC
1386-87 / 1396-97	Cylinders according to standard ISO 15552 ECOPLUS	directly on groove
1390 - 1391	Cylinders according to standard ISO 15552 ECOLIGHT	directly on groove
1370÷1373	Cylinders ECOFLAT	directly on groove
1500	Compact cylinders "Europe"	from Ø12 to Ø25: directly on groove from Ø32 to Ø50: directly on groove
	Compact cylinder according to standard ISO 21287 ECOMPACT	directly on groove
6100	Guided compact cylinder (Ø20 - Ø63)	
6101	Heavy duty guided shortstroke cylinder	
6200	Twin rod slides units	
6210	Twin through rod slides units	
6301	Pneumatic grippers, angular standard version	
6303	180° angular gripper rack & pinion style	
6310	Parallel style pneumatic grippers standard version (Ø10 - Ø25)	
6311	Parallel style pneumatic grippers wide opening	
6312	3 finger parallel style pneumatic grippers (Ø32 - Ø125)	directly on groove
6411	Single rack rotary actuators	



Round section version (for sensor slot type "C" and "D")

SERIES	DESCRIPTION	MOUNTED
6100	Guided compact cylinder (Ø12 - Ø16)	
6302	Pneumatic grippers, 180° angular	
6310	Parallel style pneumatic grippers standard version (Ø16 and Ø25)	
6312	3 finger parallel style pneumatic grippers (Ø16 - Ø25)	
6400	Double rack rotary actuators with turn table	directly on groove
6420	Vane type rotary actuators (from Ø10 to Ø40)	
6500	Arbitrary mount cylinders	
6600	Slide cylinders	
6700	Guide cylinders	



Round section 90° cable version (for sensor slot type "C" and "D")

SERIES	DESCRIPTION	MOUNTED
6420	Vane type rotary actuators	directly on groove



3 PNEUMATIC ACTUATION





## Series 1260/1320 - Piston rod lock

### General

The piston rod lock devices are clamping units mounted on the microbore cylinders front head. They allow the piston rod to lock in any position.

Piston rod clamping is mechanically obtained by springs actuated purpose-made jaws.

This method allows to lock the cylinder in the desired position, should the air pressure drop.

**The piston rod lock device is not a safety device.**

### Construction characteristics

Mounting bracket	Anodised aluminium
Body	Anodised aluminium
Clamping jaws	Hardened alloy copper
Piston	Acetal resin
Seal	NBR
Springs	Springs steel

### Operational characteristics

Fluid	Filtered air. No lubrication needed, if applied it shall be continuous.						
Working pressure	3 bar - 6 bar						
Working temperature	-5°C - +70°C						
Functioning	mechanical double jaws						
Locking	axial, two-direction (normally locked)						
Unlocking	pneumatic						
Clamping force	<u>Ø12</u>	<u>Ø16</u>	<u>Ø20</u>	<u>Ø25</u>	<u>Ø32</u>		
with static load (microbore cylinders)	180N	180N	350N	350N	600N		
Clamping force	<u>Ø32</u>	<u>Ø40</u>	<u>Ø50</u>	<u>Ø63</u>	<u>Ø80</u>	<u>Ø100</u>	<u>Ø125</u>
with static load (cylinders)	600N	1000N	1400N	2000N	5000N	5000N	7000N

"Attention: Dry air must be used for application below 0°C"

### Use and maintenance

Operate within the specified technical characteristics.

The piston rod lock does not require maintenance if properly utilised.

The working inlet port has to be pressurised for assembling the piston rod lock device on cylinder. Alternatively adjust the jaws with screw located on connection.

Spare parts are not available.

**Microbore cylinders for piston rod lock**

**Threaded end covers version**

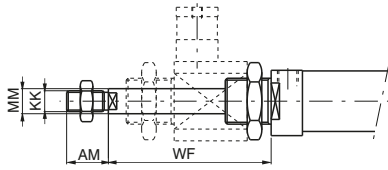

Ordering code	Order piston rod lock separately. Do not use with stainless steel or hexagonal piston rod.
<b>12_ _Ø.stroke.B</b>	

**Cylinders for piston rod lock**

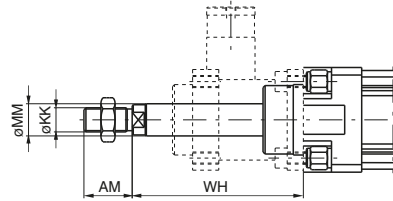

Ordering code	Order piston rod lock separately. Do not use with stainless steel piston rod.
<b>13 --Ø.stroke.--B</b>	

**Piston rod lock complete**

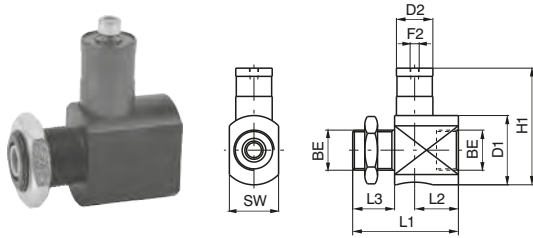

Do not use as safety device

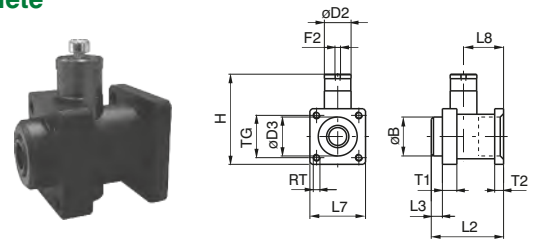

Ordering code	Ø	12	16	20	25	32
<b>1260.Ø.51BS</b>	Weight g	82	82	140	140	188

Ordering code	Ø	32	40	50	63	80	100	125
<b>1320.Ø.51BS</b>	Weight g	191	276	535	852	1772	2412	5250

**Piston rod lock bracket**

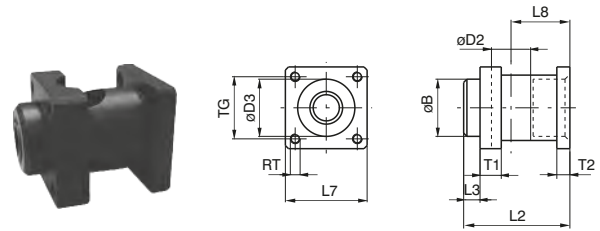
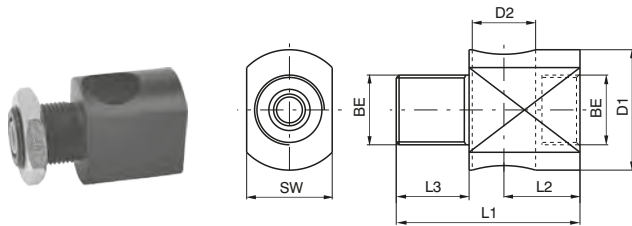

Ordering code	Ø	12	16	20	25	32
<b>1260.Ø.51S</b>	Weight g	60	60	85	85	133

Ordering code	Ø	32	40	50	63	80	100	125
<b>1320.Ø.51S</b>	Weight g	142	171	360	486	1060	1700	3500

**Piston rod lock and housing**

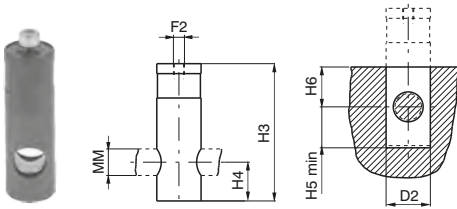

Do not use as safety device

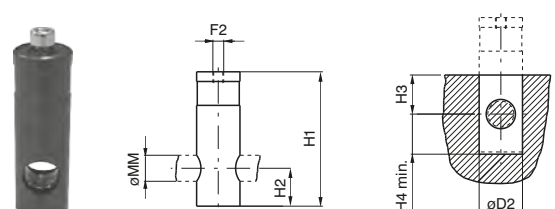

Ordering code	Ø	12	16	20	25	32
<b>1260.Ø.51B (Ø12÷Ø25)</b>	Weight g	22	22	55	55	55
<b>1320.32.51B (Ø32)</b>						

Ordering code	Ø	32	40	50	63	80	100	125
<b>1320.Ø.51B</b>	Weight g	49	105	175	366	712	712	1750

**Table of dimensions (series 1200)**

Bore	AM	BE	D1	D2	F2	H1	H3	H4	H5	H6	KK	L1	L2	L3	MM	SW	WF
12	16	M16x1,5	20	16	M5	35	35	10	11	10	M6x1	42	21	12	6	20	55
16	16	M16x1,5	20	16	M5	35	35	10	11	10	M6x1	42	21	12	6	20	55
20	20	M22x1,5	38	20	M5	64	62	17,5	19	18	M8x1,25	58	24	23	8	27	73
25	22	M22x1,5	38	20	M5	64	62	17,5	19	18	M10x1,25	58	24	23	10	27	77
32	20	M30x1,5	39,5	20	M5	64	62	17,5	18,5	18	M10x1,25	60	26	22	12	35	76,5

**Table of dimensions (series 1300)**

Bore	AM	B	D2	D3	F2	H	H1	H2	H3	H4	KK	L2	L3	L7	L8	MM	RT	T1	T2	TG	WH
32	22	30	20	30,5	M5	67	62	17,5	18	18,5	M10x1,25	58	10	45	31,5	12	M6	13	8	32,5	74
40	24	35	24	35	G 1/8"	86	83	22	22	23	M12x1,25	65	10	50	36	16	M6	13	8	38	85
50	32	40	30	40	G 1/8"	105	100	25	25	26	M16x1,5	82	12	60	45,5	20	M8	16	15	46,5	107
63	32	45	38	45	G 1/8"	121	116	30	30	31	M16x1,5	82	12	70	49,5	20	M8	16	15	56,5	107
80	40	45	48	45	G 1/8"	164	155	36	36	37	M20x1,5	110	20	90	61	25	M10	20	18	72	126
100	40	55	48	55	G 1/8"	172	155	36	36	37	M20x1,5	115	23	105	65	25	M10	20	18	89	143
125	54	60	65	60	G 1/8"	210	195	56	55	56	M27x2	167	45	140	86,5	32	M12	30	22	110	187

## Series 1260 - 1320 - Linear control units

### Construction characteristics

Body	extruded shape anodized aluminium alloy 6060
Bushings	sintered bronze
Wiper	oil resitant NBR rubber
Rods	chromed C43 steel
Plate	plated zinc steel
Mounting block	plated zinc steel

### Technical characteristics

Max. suggested strokes for 1200 series:

Diameter	20	25
Stroke mm	200	250

Max. suggested strokes for 1320 series:

Diameter	32	40	50	63	80
Stroke mm	300	350	450	500	550

On request are available strokes up to 2800 mm

Loading diagram based on dimension "A"

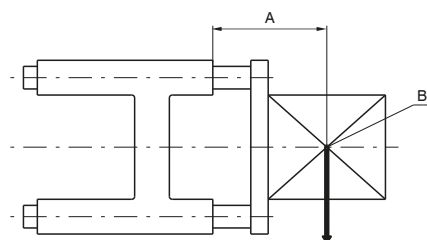

A = Protusion  
B = Load centre of gravity

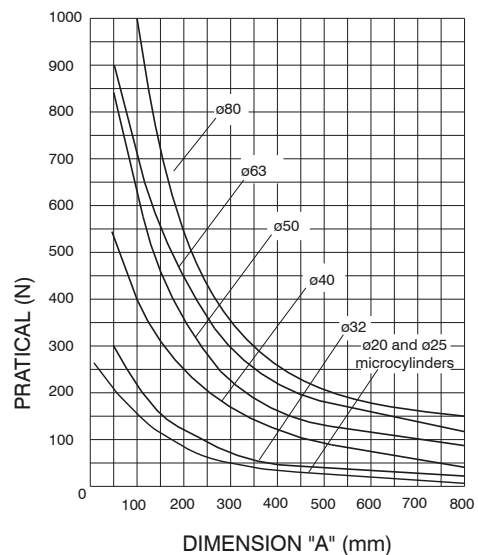

### Use and maintenance

Follow the indication of the above diagram as far as loads are concerned. A large quantity of grease is placed between the two wipers during assembly, therefore the linear control units should not require special maintenance.

Dimensions for microbore cylinders ISO 6432

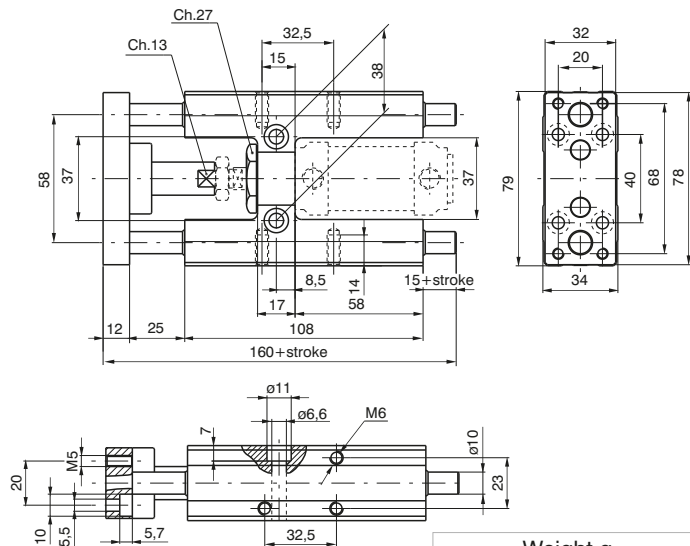

Ordering code  
**1260.Ø.stroke.GLB**  
(Microbore cylinders ISO 6432 must be ordered separately)

**Standard strokes**  
Ø 20 100 - 150 - 200 mm  
Ø 25 100 - 150 - 200 - 250 mm

Weight g	
stroke 100	every 50 mm
970	60

**Sensors and sensor clamps:** Use standard sensors and clamps.

Dimensions for microbore cylinders ISO 15552

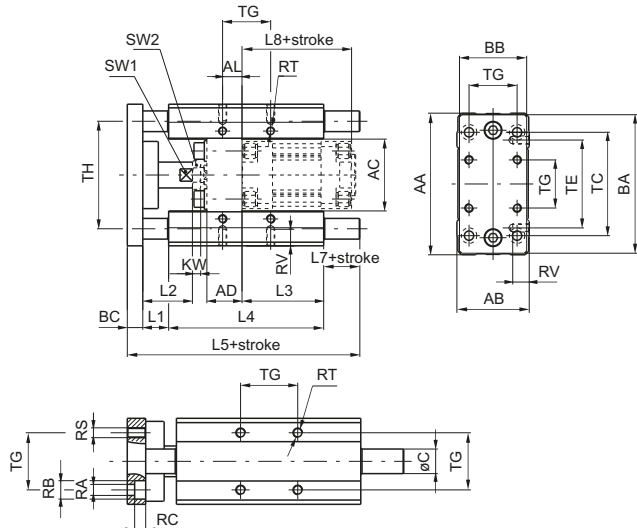

Ordering code  
**1320.Ø.stroke.GLB**  
(Cylinders must be ordered separately)

Weight g	Bore	Ø32	Ø40	Ø50	Ø63	Ø80
	stroke 100	1720	2900	4700	6000	11300
every 50 mm	91	159	159	250	380	

Bore	AA	AB	AC	AD	AL	BA	BB	BC	C	KW	L1	L2	L3	L4	L5
32	97	49	50	24	4.3	93	45	12	12	6	25	39	76	125	187
40	115	58	57.5	28	11	112	55	12	16	7	25	44	81	140	207
50	137	70	69.5	34	18.8	134	65	15	20	8	25	48	79	150	225
63	152	85	84.5	34	15.3	149	80	15	20	8	25	48	111	182	242
80	189	105	106	34	21	180	100	20	25	9	25	53	128	215	302

Bore	L7	L8	RA	RB	RC	RS	RT	RV	SW1	SW2	TC	TE	TG	TH
32	25	94	6.6	11	6.5	M6	M6	12	15	17	78	61	32.5	74
40	30	105	6.6	11	6.5	M6	M6	14	15	19	84	69	38	87
50	35	106	9	15	9	M8	M8	16	22	24	100	85	46.5	104
63	20	121	9	15	9	M8	M8	16	22	24	105	100	56.5	119
80	42	128	11	18	11	M10	M10	20	27	24	130	130	72	148

**Standard strokes**

- Ø 32 100 - 150 - 200 - 250 - 300 mm
- Ø 40 100 - 150 - 200 - 250 - 300 - 350 mm
- Ø 50 100 - 150 - 200 - 250 - 300 - 350 - 400 - 450 mm
- Ø 63 100 - 150 - 200 - 250 - 300 - 350 - 400 - 450 - 500 mm
- Ø 80 100 - 150 - 200 - 250 - 300 - 350 - 400 - 450 - 500 - 550 mm

**Sensor clamps and brackets for 1319-1320 series**  
Use standard sensors and brackets on the rear and following special brackets on front of cylinders for use sensors codes 1500.\_, RS.\_, HS.\_ which have the following ordering codes:

- 1320.AGL sensor bracket for cylinders Ø32 and Ø40
- 1320.BGL sensor bracket for cylinders Ø50 and Ø63
- 1320.CGL sensor bracket for cylinders Ø80

## Series 6900 - Dampers

### Dampers



### Ordering code

6900.

- A = Thread M8x1
- B = Thread M10x1
- C = Thread M14x1.5
- D = Thread M20x1.5
- E = Thread M27x1.5

### Operational characteristics

Code	Max. power (Nm)		Return force	Operating temperature	Weight
	For cycle	For hour			
6900.A	4	14400	2,5 - 6 N	-20°C - 80°C	10 gr.
6900.B	15	24000	3,6 - 8 N		20 gr.
6900.C	30	50000	13 - 23 N		50 gr.
6900.D	100	76500	12 - 23 N		140 gr.
6900.E	390	175500	14 - 31 N		340 gr.

### Overall dimensions

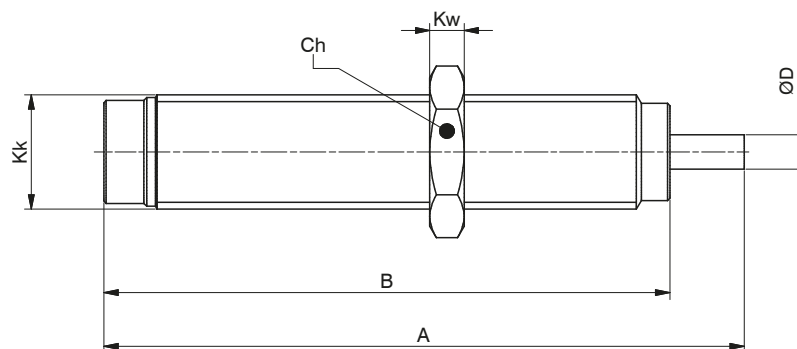

### Table of dimensions

Code	A	B	Ch	D	Kk	Kw
6900.A	51	44	11	2,5	M8x1	3
6900.B	56	49,5	13	3	M10x1	3
6900.C	79	69	17	4	M14x1,5	5
6900.D	107	88	24	6	M20x1,5	6
6900.E	126,5	108,5	30	8	M27x1,5	8

# Appendix

## Pneumatic symbols

### Air treatment

#### Air treatment mechanisms

Pneumatic accumulator  
(capacity)



Automatic drain air



Automatic drain air



Lubricator



Air filter



Filter - with manual drain



Filter - with automatic drain



#### Pressure control valves

Pressure switch

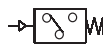

Free discharge pressure relief valve



Free discharge pilot-operated  
pressure relief valve

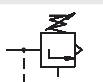

Sequence valve

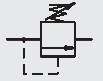

Pressure regulator



Pressure regulator  
without exhaust valve



Pilot-operated pressure regulator  
without exhaust valve



Pressure regulator without  
exhaust valve (free)



Differential pressure regulator

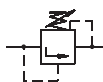

#### Assembled units

Filter pressure regulator

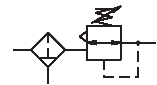

Filter pres. reg. + lubricator  
Filter + pres. reg. + lubricator

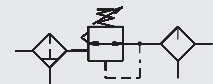

#### Other mechanisms

Pressure gauge



Shut-off valve

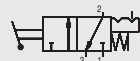

Progressive start-up valve  
With Electric control

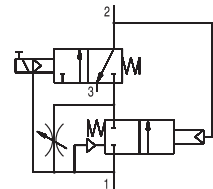

Progressive start-up valve  
With Pneumatic control

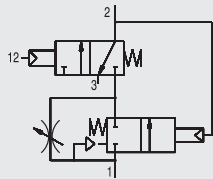



## Valves and solenoid valves

### Terms and descriptions

The connections to the inlet and outlets of the valves can be of two types:

**Main connections** - supply connection identified with number 1

- consumption connection identified with number 2 and 4

- exhaust connection identified with number 3 and 5

**Pilot connections** - repositioning connection on 2/2 & 3/2 ways valves identified with number 10

- switching connection on 2/2 & 3/2 ways valves and repositioning connection on 5/2 & 5/3 ways valves identified with number 12

- switching connection on 5/2 & 5/3 ways valve identified with number 14

**Switching:** is the process that changes the state of a valve from rest position to actuated position and is achieved by means of a mechanical, pneumatic or electric signal.

**Repositioning:** is the process that changes the valve state from actuated back to rest position and is achieved by means of an external mechanical (spring), pneumatic (differential) or electric signal.

**Ways:** indicated the number of connections on the valve body and on the pneumatic diagram.

**Positions:** indicates the number of positions achieved by the valve and corresponds to the number of squares on the pneumatic simple.

**Function:** indicates the valve working diagram at rest condition and corresponds to the right square in the pneumatic scheme.

### Valves symbols

Way	Pos.	Function	Symbol
2	2	Normally closed	
2	2	Normally open	
3	2	Normally closed	
3	2	Normally open	
5	2	Separated exhaust connections	
5	3	Closed centres	
5	3	Open centres	
5	3	Pressured centres	

### Complementary valves

Throttle valve	
Bidirectional flow regulator	
Unidirectional flow regulator	
Quick exhaust valve	
Shuttle valve	
Silencer	
Non-return valve without spring	
Non-return valve with spring	
Non-return valve controlled during closing	
Non-return valve controlled during opening	

### Switching and Repositioning

#### Mechanical

Plunger	
Sensitive plunger	
Roller	
Unidirectional roller	
Sensitive roller	
Pedal	
Pedal - spring return	
Push Button	
Sensitive push button	
Push button - two positions-	
Lever	
Lever - spring to center	
Sensitive lever	
Two position mechanical stop	
Three position mechanical stop	
Spring	

#### Pneumatics

Pneumatic	
Pneumatic -return to center	
Pneumatic - depressurised	
Differential (pneumatic spring)	
Differential external pilot	
Sensitive differential	

#### Electrical

Solenoid	
Bistable solenoid	
Solenoid (internal pilot)	
Solenoid (external pilot)	
Solenoid - spring to center	
Solenoid with suppl. pilot	

## Valves and solenoid valves (following)

### Piping and connections

Pressure line	
Control line	
Exhaust line	
Flexible line	
Electric line	
Piping connections	
Piping intersection	
Main air connection	

One-way rotating intake	
Three-way rotating intake	
Closed air intake	
Air intake with connection	
Quick coupling connection without non-return valve	
Quick coupling connection with non-return valve	
Air exhaust unthreaded connection	
Air exhaust threaded connection	

## Cylinders

### Single acting cylinders

With external return	
With spring return	
With spring return	

### Double acting cylinders

Standard rod	
Double rod (through rod version)	
With non adjustable cushioning	
With adjustable cushioning	
With magnetic piston	
With magnetic piston with adjustable cushioning	

### Tandem cylinders

In tandem, common rod	
In tandem, independant rods	
In tandem, opposite rods	
Opposed, common rod	

### Non rotating cylinders

Standard rod / double acting	
Twin rod / double acting	
Twin rod / double acting through rod	
Twin through rod, double acting	
Guided compact cylinders	

### Cylinders for piston rod lock

With magnetic piston with adjustable cushioning	
With non magnetic piston with adjustable cushioning	

### Rodless cylinders

With magnetic piston With adjustable cushioning	
Cable cylinders with magnetic piston	
Cable cylinders with non magnetic piston	

### Telescopic cylinders

Single acting	
Double acting	

### Various cylinders

Rotating cylinders	
Rotating cylinder	
Bellows cylinder	

### Pressure boosters

Air-Air intensifier	
Air-oil intensifier	
Hydropneumatic accumulator	

APPENDIX A



# Dimensioning

## Flow characteristics

Each cylinder requires, in order to generate specific forces and operate at the needed speed, specific air flow through the control valve. It is therefore necessary to know and understand the laws that regulate the flow through a valve; and therefore the relation between pressure, pressure drop and flow rate. Only by doing so is it possible to determine whether a valve is capable of supplying the required flow rate to a cylinder at a given inlet pressure and with a reasonable pressure drop.

In order to carry out these analyses it is necessary to work with precise functional data; it is not sufficient to know the valve port size. This data is presented in different ways depending on the different applicable standards and various experimental measurements methods.

The figures are mainly coefficients which must be used in specific equations, with which we can estimate the valve flow rate. In order to understand the meaning of these equations it is necessary to examine the flow inside a pneumatic valve. For example, let us consider the following conditions: a valve supplied with an absolute pressure P1 and with a flow regulator connected downstream.

### Starting condition - flow regulator closed

- no flow rate (Q=0)
- Upstream and downstream pressure are identical (P2=P1)

### Intermediate conditions - opening flow regulator

By progressively opening the flow regulator the pressure P2 will decrease and the flow rate increase up to a critical point at which the flow rate becomes constant even if the flow regulator is opened further. This critical point corresponds to the sonic condition of the flow.

### Final condition - flow regulator completely open

- maximum flow rate (constant from critical point)
- downstream pressure P2=0

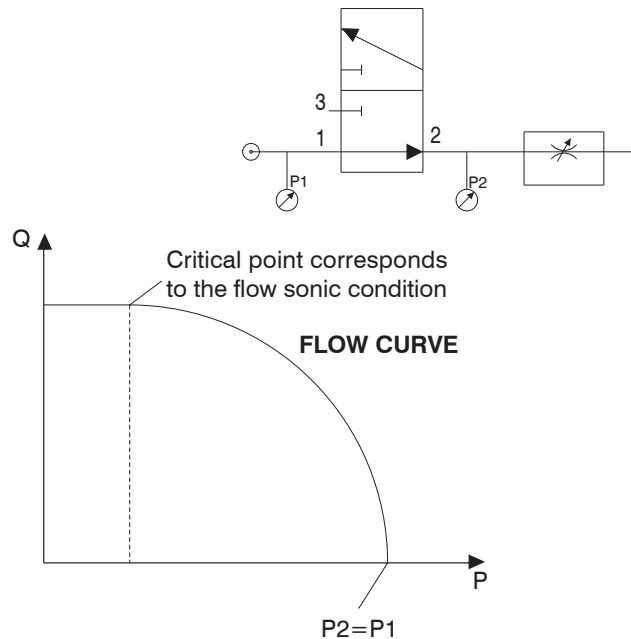

On a varying P1 the curves maintain the same form and only shift into a higher or lower flow rate area depending on whether P1 has increased or decreased. The area of interest in pneumatic valve applications is the subsonic zone, just before the critical flow point is reached. This zone is expressed in a number of different ways which average the effective flow pattern enabling simple description of the flow using experimental coefficients.

## Valve coefficients "C" e "B"

CETOP RP50P recommendation (derived from ISO 6358 standard) expresses flow rate in function of two experimental coefficients:

- conductance C
- critical pressure ratio b.

**Conductance C = Q\*/P1** is the ratio between maximum flow rate Q\* and absolute inlet pressure P1 under sonic flow condition at a temperature of 20°C.

**Critical ratio b = P\*2/P1** is the ratio between the output absolute pressure P2 and the inlet absolute pressure P1 at which the flow becomes sonic.

The expression that represents an elliptic approximation of the relationship between pressure and flow follows:

$$Q_N = C \cdot P_1 \cdot K_t \cdot 1 - \left( \frac{r - b}{1 - b} \right)^2 \quad [1]$$

where:

- QN (dm<sup>3</sup>/s) is the flow rate in dm /s at normal condition : 1,013 bar and 20°C;
- C (  $\frac{dm^3}{s \cdot bar}$  ) is the valve conductance;
- P1 (bar) is the inlet absolute pressure;
- r is the ratio between downstream and upstream pressure (P2/P1);
- b is the pressures critical ratio;
- kt =  $\sqrt{293/T_1}$  is a corrective factor that consider the absolute inlet temperature T1;
- T1 = 273 + t1 (°K) is the absolute temperature (t1 is the temperature in °C).

The experimental determination of the valve coefficient C & b is carried out with compressed air following standardised procedures and according to the scheme below.

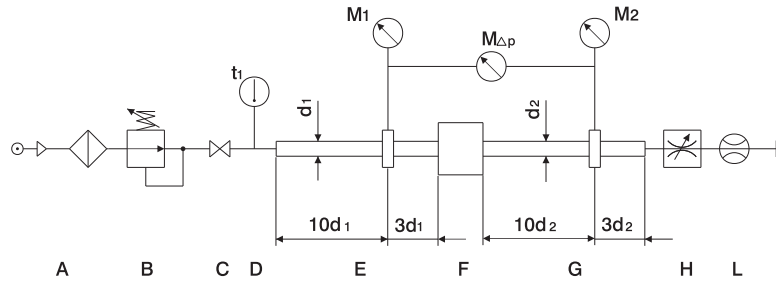

**CETOP test circuit**

- A Compressed air generator.
- B Pressure regulator to set upstream pressure P1.
- C Shut off valve.
- D Temperature sensor to check upstream temperature t 1, positioned in a low velocity area.
- E Pipe where the upstream pressure is measured.
- F Test valve.
- G Pipe where the downstream pressure is measured.
- H Flow regulator to adjust the downstream pressure P2.
- L Flow meter.
- M1,M2 Pressure measuring equipment for upstream and downstream.
- MΔP Pressure drop measuring equipment assuming P1-P2 < 1 bar.

Pipes E & G, used to measure the valve upstream and downstream pressure, must be sized according to the standard's specifications and change in size depending on the valve port sizes; the position of the connection at which the measurements are taken depends on the pipe's inner diameter.

Conductance C is determined with the following equation, measuring the critical flow rate Q\* through the valve, where upstream pressure P1 is constant and greater than 3 bar.

$$C = \frac{Q^*}{P_1 \cdot K_t} \quad [2]$$

Pressure critical ration **b** can be calculated using the following equation:

$$b = 1 - \frac{\Delta P}{P_1 \left[ 1 - \sqrt{1 - \left( \frac{Q'}{Q^*} \right)^2} \right]} \quad [3]$$

Considering a given constant pressure P1 it is necessary to proceed measuring the flow rate Q' corresponding to a pressure drop DP = P1-P2 = 1 bar. Equation 3 is used to calculate the critical ratio as it is difficult to experimentally identify the exact pressure P\*2 at which the flow becomes sonic. The values of both the conductance C and the critical ratio b are experimentally calculated and are the average of the results obtained.

Equation [1] is used to calculate the flow in subsonic conditions P2 > b · P1 when values C ; b and the valve working conditions (P1, P2, T1) are known. Under sonic conditions , P2 ≤ b · P1 the equation can be simplified and the maximum flow rate can be calculated as follows:

$$Q^* = C \cdot P_1 \cdot k_t \quad [4]$$

**HYDRAULIC COEFFICIENT KV**

The hydraulic coefficient allows, using the equation. The calculation of the flow rate of a fluid through a valve.

$$Q = K_v \sqrt{\frac{\Delta p}{\rho}} \quad (l/min) \quad [5]$$

where:

- Q is the fluid flow rate in l/min
- Δp is the pressure drop inside the valve calculated in bar (P1 - P1)
- ρ is the fluid density calculated in Kg/dm<sup>3</sup>
- Kv is the hydraulic coefficient calculated in  $\frac{l}{min} \left( \frac{kg}{dm^3 \cdot bar} \right)^{1/2}$

Using these measurement units the flow rate coefficient Kv represents the flow rate (in liters) of water across the valve with a pressure drop of 1 bar. The measurement are carried out using the standardised circuit below on which the connection ports are positioned according to the pipe inner bore size (norm VDE/VDI 2173).

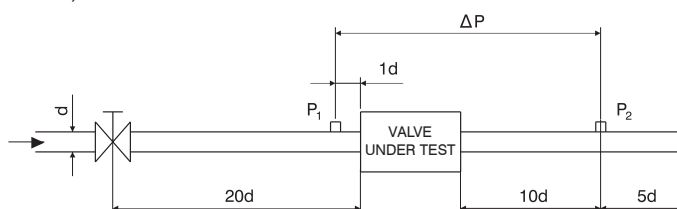



**Hydraulic circuit**

In some cases flow rate is measured in m<sup>3</sup>/h which correspond a Kv measured

To obtain Kv expressed in  $\frac{l}{min} \left( \frac{kg}{dm^3 \cdot bar} \right)^{1/2}$  it is sufficient to multiply the Kv value expressed in  $\frac{m^3}{h} \left( \frac{kg}{dm^3 \cdot bar} \right)^{1/2}$  by the coefficient 16,66.

The coefficient kv is perfectly suitable to express the flow rate of fluids but only gives approximate values in case of compressed air. Experiences gained in hydraulic environments can be inferred in the pneumatic field, bearing in mind the difference in density, and assuming that the air flow will generate the same pressure drops and flow reductions as water. It is therefore possible to calculate reliable values for compressed air using flow coefficients Kv obtained from experiments with water.

To define the flow rate Qn through a valve at a given constant absolute inlet pressure P1, regardless of fluctuations of the downstream absolute pressure P2, refer to the equation below:

$$Q_N = 28,6 \cdot K_v \sqrt{P_2 \cdot \Delta P} \cdot \sqrt{\frac{T_n}{T_1}} \tag{6}$$

where:

- Q<sub>N</sub> is the flow rate in volume l/min;
- K<sub>v</sub> is the hydraulic coefficient  $\frac{l}{min} \left( \frac{kg}{dm^3 \cdot bar} \right)^{1/2}$
- T<sub>n</sub> is the absolute reference temperature;
- T<sub>1</sub> is the inlet absolute temperature in °K;
- P<sub>2</sub> is the downstream absolute pressure in bar;
- ΔP is the pressure drop P<sub>1</sub> - P<sub>2</sub> in bar.

Equation [6] is real up to  $\Delta P = \frac{P_1}{2}$  therefore  $P_2 = \frac{P_1}{2}$

For lower P2 values the flow rate is considered to be constant, corresponding to the sonic flow rate Q\*N given by the following equation:

$$Q^*_N = 14,3 \cdot K_v \cdot P_1 \sqrt{\frac{T_n}{T_1}} \tag{7}$$

**The nominal flow rate QNn**

The nominal flow rate is the flow volume (at normal conditions) that passes through a valve with an upstream pressure P1=6bar (7 bar absolute pressure) and a pressure drop of 1 bar, corresponding to a downstream relative pressure P2 of 5bar (6 bar absolute pressure).

Normally the nominal flow rate is expressed in l/min and can be easily deduced from an experimental flow curve drawn for a upstream pressure of 6 bar (relative). Nominal flow rate can be useful for a preliminary assesment of the performances of different valves but in reality can be used only if the working conditions are the same as those mentioned before. In order to be able to compare valve characteristics which are expressed in different coefficients it is possible to use conversion equations.

Given the C and b coefficient, it is possible to determine the nominal flow rate using the following equation:

$$Q_{Nn} = 420 \cdot C \cdot \sqrt{1 - \left( \frac{0,857 - b}{1 - b} \right)^2} \tag{8}$$

where:

$$Q_{Nn} = \dot{v} \text{ in l/min e } C \text{ in } \frac{dm^3}{s \cdot bar}$$

The correlation between the hydraulic coefficient KV and the corresponding nominal flow rate is as follows:

where:

$$Q_{Nn} = 66 K_v$$

$$Q_{Nn} \dot{v} \text{ in l/min e } K_v \text{ in } \frac{l}{min} \left( \frac{kg}{dm^3 \cdot bar} \right)^{1/2}$$

**Conversion table**

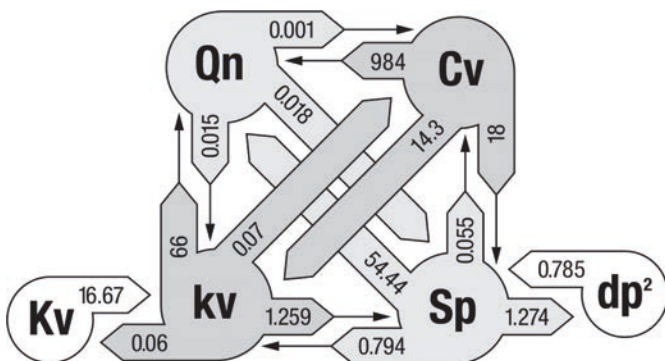

<b>Qn</b>	Nominal flow rate	NI/min
<b>kv</b>		l/min
<b>Kv</b>	Hydraulic coefficient	m <sup>3</sup> /hours
<b>Cv</b>		USA gallons/min
<b>Sp</b>	Nominal inner section area	mm <sup>2</sup>
<b>dp<sup>2</sup></b>	Nominal diameter*	mm <sup>2</sup>

\*to calculate the diameter dp (mm<sup>2</sup>) square root of dp<sup>2</sup>

### Pipes flow resistance

The C factor (l/sec) indicates the pipe flow capacity and is the ratio between the maximum flow rate and absolute pressure (ISO 6358). The flow capacity progressively decreases with increasing pipe length, due to the air friction on the pipe inner surface increasing the pressure drop. Therefore the longer the pipe the smaller the flow rate. The chart below shows the flow rate characteristics of different pipe sizes (i/d and o/d) in function of the length.

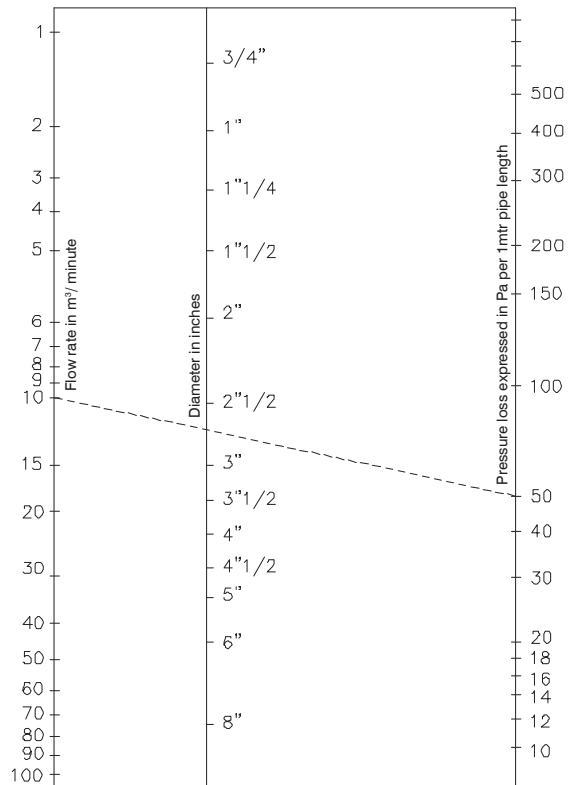

### Valve sizing

The choice of the correct size valve is essential in order to ensure that the cylinder to be controlled will perform as expected. It is therefore necessary to know the cycle time to be achieved and to calculate the coefficient T which will be used as multiplier for the air consumption value previously calculated. The result of this equation, expressed in NI/min and multiplied by a safety factor of 1.2, corresponds to the minimum flow rate needed (at standard conditions 6 bar supply and 5 bar on the consumption connection) to operate the cylinder at the required rate.

$$T = \frac{60 Q_n}{\text{cycle time}} = T \times \text{Consumption}$$

It is also important to ensure that the pipes used to connect the valve to the air supply and to the cylinder do not affect the flow rate in any way. The pipe inner bore must therefore be at least 1.5 times the diameter of the valve nominal orifice size. The choice of the fittings is also very important, the inner bore must be equal or greater than the pipe I/D. The diagram below shows the flow rate required to operate different size cylinders at varying speeds and also the valve connection sizes.

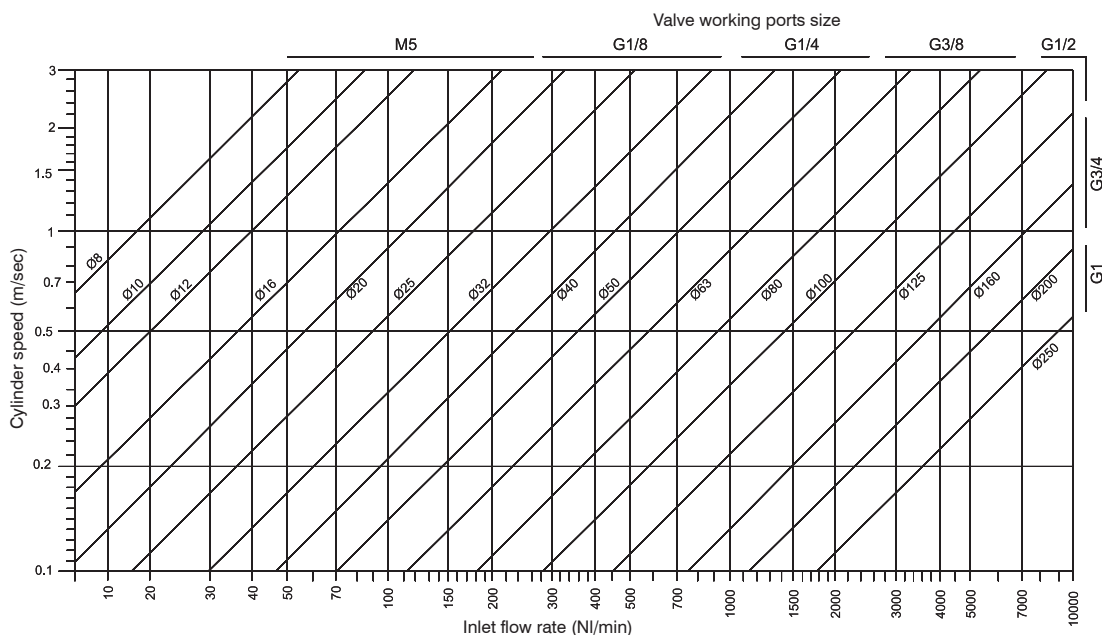

A

APPENDIX



### Cylinder air consumption

The air consumption corresponds to the volume of air that the cylinder uses in a complete cycle ( stroke out and back in ) at a specific pressure.

$$\text{Consumption} = Pa \times C \times (A+b)$$

**Pa**= Absolute pressure (bar)

**C**= Cylinder stroke (dm)

**A**= see tab. 1 (dm<sup>2</sup>)

**b**= see tab. 2 (dm<sup>2</sup>)

Air consumption is measured in Normal-liters (NI) which correspond to the volume that a specific quantity (mass) of gas would fill at atmospheric pressure.

Calculation example:

ISO 15552 cylinder - 1319 series:

Supply pressure 6 bar (Pa=7 bar)

stroke 50mm (C=0,5 dm)

Ø63 (A=0,31157 dm<sup>2</sup>)

Rod Ø=20 mm (b=0,28017 dm<sup>2</sup>)

$$\text{Consumption} = 7 \text{ (bar)} \times 0,5 \text{ (dm)} \times (0,31157 + 0,28017) = \mathbf{2,072 \text{ NI}}$$

(In order to calculate the air consumption for a specific number of cycles it is sufficient to multiply the above value for the number of cycles)

Piston surface area	
Ø cylinder	A
Ø 8	0,00502 dm <sup>2</sup>
Ø 10	0,00785 dm <sup>2</sup>
Ø 12	0,01130 dm <sup>2</sup>
Ø 16	0,02010 dm <sup>2</sup>
Ø 20	0,03140 dm <sup>2</sup>
Ø 25	0,04906 dm <sup>2</sup>
Ø 32	0,08038 dm <sup>2</sup>
Ø 40	0,12560 dm <sup>2</sup>
Ø 50	0,19625 dm <sup>2</sup>
Ø 63	0,31157 dm <sup>2</sup>
Ø 80	0,50240 dm <sup>2</sup>
Ø 100	0,78500 dm <sup>2</sup>
Ø 125	1,22656 dm <sup>2</sup>
Ø 160	2,00960 dm <sup>2</sup>
Ø 200	3,14000 dm <sup>2</sup>

tab.1

Surface difference cylinder piston / rod Ø	
Ø cylinder - Ø rod	A
Ø 8 - Ø 4	0,00377 dm <sup>2</sup>
Ø 10 - Ø 4	0,00659 dm <sup>2</sup>
Ø 12 - Ø 6	0,00848 dm <sup>2</sup>
Ø 16 - Ø 6	0,01727 dm <sup>2</sup>
Ø 20 - Ø 8	0,02638 dm <sup>2</sup>
Ø 25 - Ø 10	0,04121 dm <sup>2</sup>
Ø 32 - Ø 12	0,06908 dm <sup>2</sup>
Ø 40 - Ø 14	0,11021 dm <sup>2</sup>
Ø 40 - Ø 16	0,10550 dm <sup>2</sup>
Ø 40 - Ø 18	0,10017 dm <sup>2</sup>
Ø 50 - Ø 14	0,18086 dm <sup>2</sup>
Ø 50 - Ø 18	0,17082 dm <sup>2</sup>
Ø 50 - Ø 20	0,16485 dm <sup>2</sup>
Ø 63 - Ø 20	0,28017 dm <sup>2</sup>
Ø 63 - Ø 22	0,27357 dm <sup>2</sup>
Ø 80 - Ø 22	0,46441 dm <sup>2</sup>
Ø 80 - Ø 25	0,45334 dm <sup>2</sup>
Ø 100 - Ø 25	0,73594 dm <sup>2</sup>
Ø 100 - Ø 30	0,71435 dm <sup>2</sup>
Ø 125 - Ø 30	1,15591 dm <sup>2</sup>
Ø 125 - Ø 32	1,14618 dm <sup>2</sup>
Ø 160 - Ø 40	1,88400 dm <sup>2</sup>
Ø 200 - Ø 40	3,01440 dm <sup>2</sup>

tab.2

### Allowed axial load (combined bending and compressing load)

This is the maximum load that can be applied axially on the rod tip. Above this value the rod might bend under compression. This value depends on a number of factors such as load size, rod diameter, the distance at which the load is applied (bending and compressing length L) and the conditions under which the load is applied (cylinder mountings). Among the possible conditions, the following three are the most common.

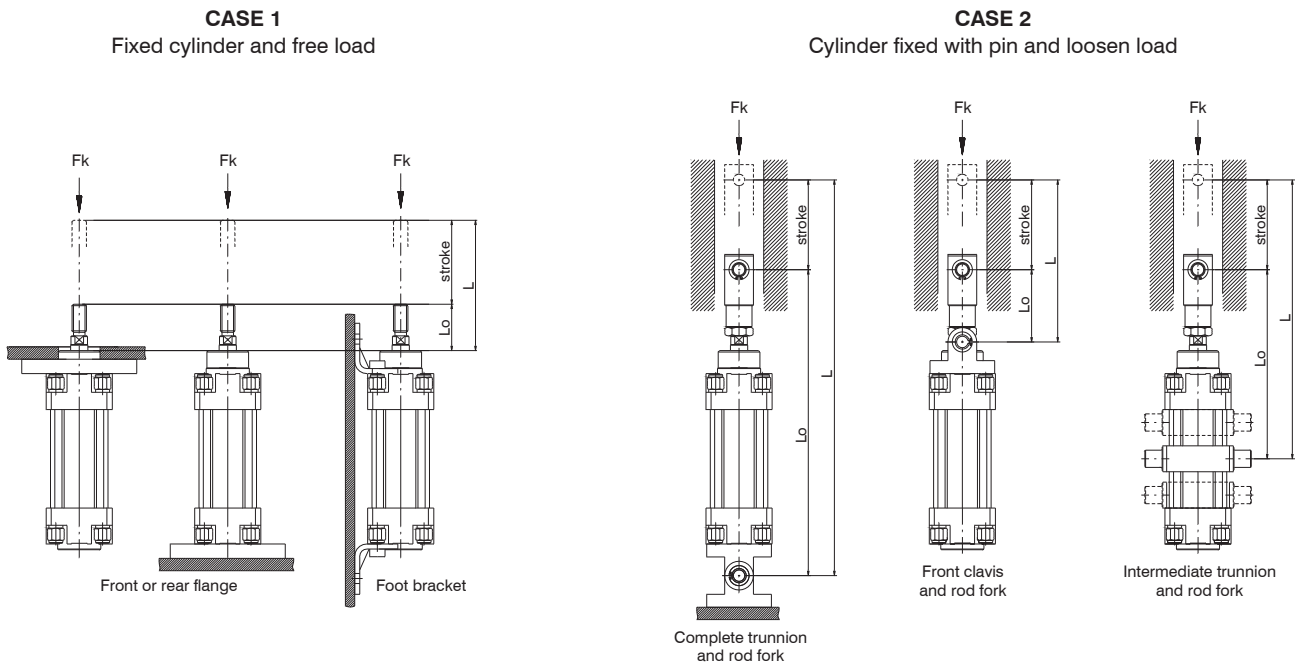

The maximum axial load can be calculated in two ways:

In an empirical way (see equations) or by checking the following diagram which shows the worst possible conditions (case 1 & 2). For all other possible mounting alternatives the axial load will surely be higher.

$$F_k = \frac{p^3 \times E \times d^4}{64 \times L^2 \times C} \quad (N)$$

$$d = \sqrt[4]{\frac{F_k \times 64 \times L^2 \times C}{p^3 \times E}} \quad (cm)$$

$$L = \sqrt{\frac{p^3 \times E \times d^4}{F_k \times 64 \times C}} \quad (cm)$$

#### Example: Axial load verification

Cylinder  $\varnothing 80$  mm  
Rod diameter  $\varnothing 20$  mm  
Stroke 600 mm  
Mounting CASE 2 intermediate trunnion:  $L_0 = 290$  mm  
Carico 2000 N  
 $L$  (distance) =  $29 + 60 = 89$  cm  
 $3742 F_k = (p \times 2,1 \times 10 \times 2) : (64 \times 89 \times 5) = 4104 N$   
(Above the 2000 N applied)

The same result can be obtained using the below diagram: following the bending and compression distance line relative to 900mm up to the intersection with the 20mm  $\varnothing$  line we obtain 4000N.

#### Example: Rod diameter sizing

**E** = rod material coefficient of elasticity (N/cm<sup>2</sup>)  
(steel =  $2,1 \times 10^7$  N/cm<sup>2</sup>)  
**d** = rod diameter (cm)  
**L** = bending and compression distance (cm)  
**C** = safety factor (da 2,5 a 5)

Considering the same conditions as in the above case we need to determinate the rod diameter suitable to withstand a 4000N load

$$d = \sqrt[4]{(4000 \times 64 \times 89^2 \times 5) / (p^3 \times 2,1 \times 10^7)} = 2 \text{ cm}$$

The diameter to choose is the next one up:  $\varnothing 25$  mm

Also this second example can be resolved using the below diagram: following the bending and compression distance line relative to 900mm up to the intersection with the 4000N maximum load we obtain  $\varnothing 20$  mm.

With the third equation or using the diagram it is possible to calculate the bending and compression distance.

A

APPENDIX

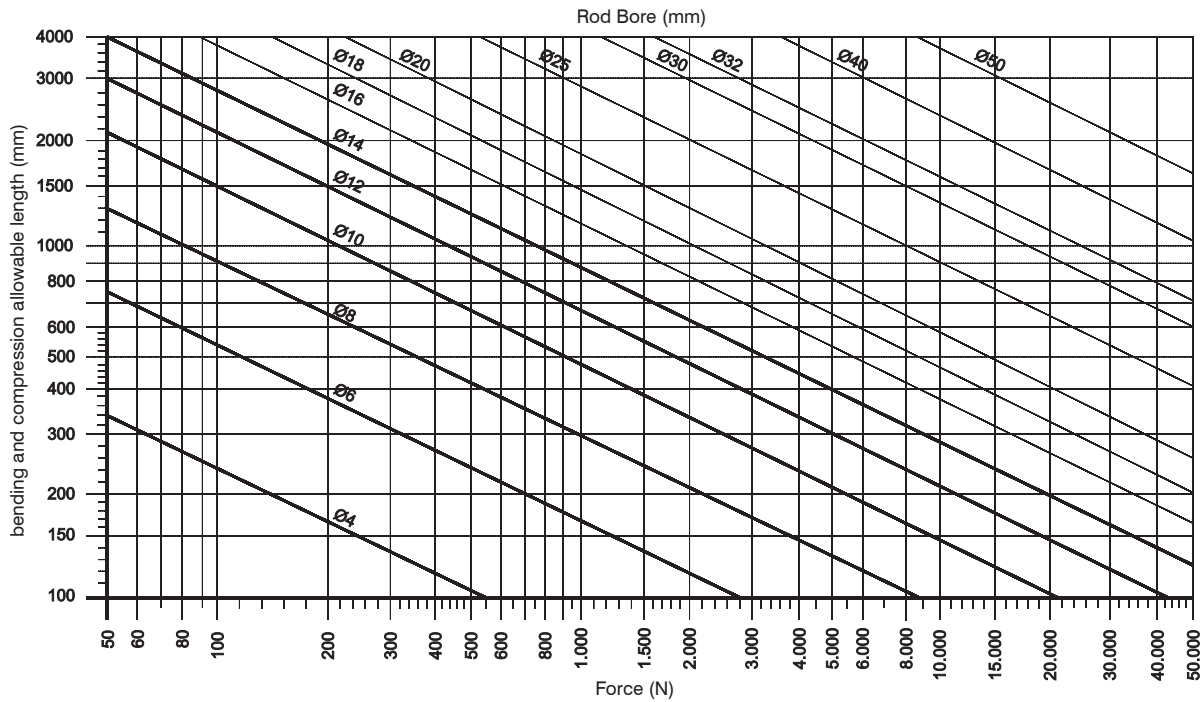

### End of stroke cushioning capability

The function of the end of stroke cushioning is to reduce the kinetic energy generated by movement of the load and to prevent high speed impact between the piston and end caps that could compromise the unit functionality. The use of non-cushioned cylinders is not recommended on high speed applications unless external means of deceleration (such as dampers) are used.

The maximum load that can be cushioned depends on the speed of the unit and the cylinder cushioning capacity. The chart below shows the values relative to the ISO 15552 series cylinders considering the out stroke movement and a supply pressure of 6 bar. The acceptable values for any diameter are those found below each size line.

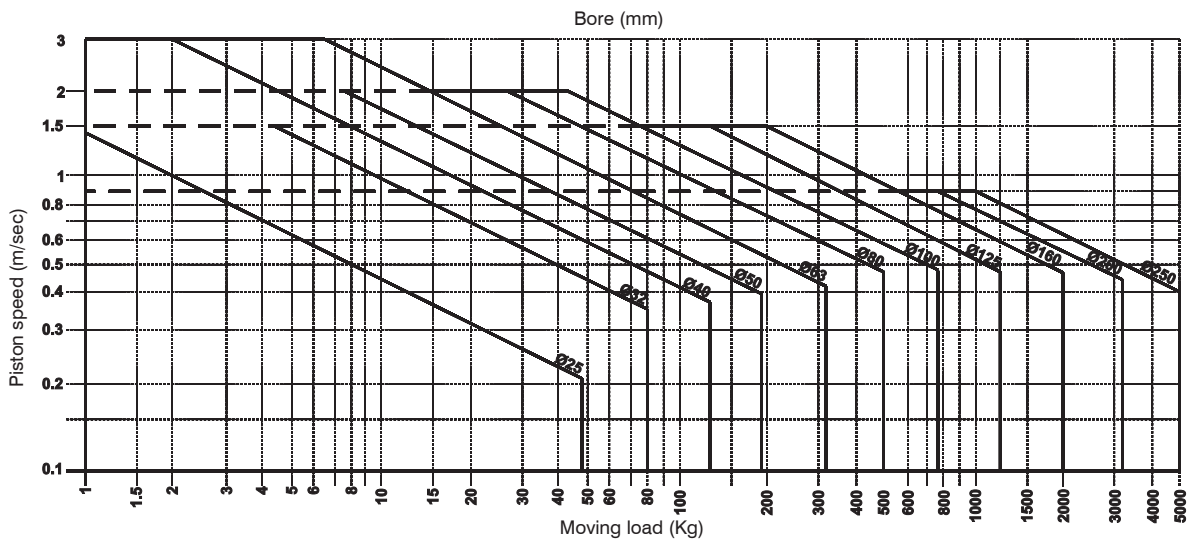

### Cylinder sizing

In order to properly size a cylinder it is necessary to consider the following parameters:

**Force generated:** calculated in function of the piston area and of the pressure that acts upon it.

$$F = \text{area} \times \text{pressure} \quad (\text{daN}) = (\text{cm}^2) \times (\text{bar})$$

The value is theoretical and needs to be reduced by approximately 10-15% in order to compensate for the effects of friction. We must also consider that the force generated during the return stroke (traction) is lower, as the area on which the pressure acts is reduced by the presence of the rod.

**Weight of the load:** the force generated by the cylinder must be sufficient to move the load in the desired direction within the specified time (cycle time). The load ratio (RdC) must not exceed 70%.

$$\frac{\text{Needed force (load weight)}}{\text{Available force (generated)}} \times 100 = \text{RdC}$$

### Load position

**Vertical lift** (pull upwards): the real force generated by the cylinder must be sufficient to counterbalance the load and to accelerate it.

Example:

Weight to be lifted 120Kg

Working pressure 6 bar

Load ratio 70%

Using the load ratio equation it is possible to calculate the force needed to lift the load:

$$\text{Available force} = \frac{\text{Load}}{\text{Rdc}} \times 100 \quad \text{the result is } 171,4 \text{ daN}$$

A 63 bore cylinder which generates a theoretical force of 187 daN is suitable for the application.

A similar load ratio allows, using unidirectional flow regulators, good speed control.

When the speed is below 20mm/sec. It is difficult to properly control the movement.

The load ratio must be reduced to 50% on slow speed applications. In these conditions, or where constant movement is required, the use of a hydraulic speed control unit is recommended. On applications where the load is moving downwards, thereby increasing the force generated by the actuator, it is usually necessary to use flow regulators.

**Horizontal or inclined movement:** If the load is supported and the working position is horizontal, it is necessary to multiply the needed force by the coefficient of friction.

The coefficient of friction *m* varies according to the material.

For example considering *m* = 0.4

Weight to be moved 120Kg

Pressure 6 bar

Load ratio 70%

Solving the load ratio equation it is possible to calculate the available force:

$$\text{Available force} = \frac{\text{Load}}{\text{Rdc}} \times 100 \quad \text{which, in the above conditions is } 68,57 \text{ daN}$$

A Ø40 bore cylinder that generates a theoretical force of 75.4 daN is suitable for the application.

In cases of inclined application the required force increases according to the angle.

Also in these conditions it is necessary to multiply the needed force by a coefficient of friction.

### THEORETICAL FORCE -PUSH- (N) - rod moving out

Bore (mm)	Push area (mm <sup>2</sup> )	Feeding pressure (bar)									
		1	2	3	4	5	6	7	8	9	10
Ø 6	28	2,5	5,5	8	11	13,5	16,5	19	22	24,5	27,5
Ø 8	50	4,5	9,5	14,5	19,5	24,5	29,5	34	39	44	49
Ø 10	79	7,5	15	23	30,5	38	46	53,5	61,5	69	76,5
Ø 12	113	11	22	33	44	55	66	77	88	99	110
Ø 16	201	19	39	59	78	98	118	137	157	177	197
Ø 20	314	30	61	92	123	153	184	215	246	277	307
Ø 25	491	48	96	144	192	240	288	336	384	433	481
Ø 32	804	78	157	236	315	394	472	551	630	709	788
Ø 40	1.256	123	246	369	492	615	739	862	985	1.108	1.231
Ø 50	1.963	192	384	577	769	962	1.154	1.347	1.539	1.732	1.924
Ø 63	3.116	305	611	916	1.222	1.527	1.833	2.138	2.444	2.749	3.055
Ø 80	5.024	492	985	1.478	1.970	2.463	2.956	3.448	3.941	4.434	4.926
Ø 100	7.850	769	1.539	2.309	3.079	3.849	4.618	5.388	6.158	6.928	7.698
Ø 125	12.266	1.202	2.405	3.608	4.811	6.014	7.217	8.419	9.622	10.825	12.028
Ø 160	20.096	1.970	3.941	5.912	7.882	9.853	11.824	13.795	15.765	17.736	19.707
Ø 200	31.400	3.079	6.158	9.237	12.317	15.396	18.475	21.555	24.634	27.713	30.792
Ø 250	49.063	4.811	9.622	14.434	19.245	24.056	28.868	33.679	38.491	43.302	48.113

### Surface difference - Cylinder piston / rod Ø

Ø cylinder - Ø rod	b
Ø 8 - Ø 4	0,377 cm <sup>2</sup>
Ø 10 - Ø 4	0,659 cm <sup>2</sup>
Ø 12 - Ø 6	0,848 cm <sup>2</sup>
Ø 16 - Ø 6	1,727 cm <sup>2</sup>
Ø 20 - Ø 8	2,638 cm <sup>2</sup>
Ø 25 - Ø 10	4,121 cm <sup>2</sup>
Ø 32 - Ø 12	6,908 cm <sup>2</sup>
Ø 40 - Ø 14	11,021 cm <sup>2</sup>
Ø 40 - Ø 16	10,550 cm <sup>2</sup>
Ø 40 - Ø 18	10,017 cm <sup>2</sup>
Ø 50 - Ø 14	18,086 cm <sup>2</sup>
Ø 50 - Ø 18	17,082 cm <sup>2</sup>
Ø 50 - Ø 20	16,485 cm <sup>2</sup>
Ø 63 - Ø 20	28,017 cm <sup>2</sup>
Ø 63 - Ø 22	27,357 cm <sup>2</sup>
Ø 80 - Ø 22	46,441 cm <sup>2</sup>
Ø 80 - Ø 25	45,334 cm <sup>2</sup>
Ø 100 - Ø 25	73,594 cm <sup>2</sup>
Ø 100 - Ø 30	71,435 cm <sup>2</sup>
Ø 125 - Ø 30	115,591 cm <sup>2</sup>
Ø 125 - Ø 32	114,618 cm <sup>2</sup>
Ø 160 - Ø 40	188,400 cm <sup>2</sup>
Ø 200 - Ø 40	301,440 cm <sup>2</sup>

tab.2





### Single acting cylinder spring initial and final load characteristics

Microbore cylinders ISO 6431 - 1260 series			Bore						
	Front spring	Rear spring	Ø 12	Ø 16	Ø 20	Ø 25	Ø 32	Ø 40	Ø 50
Initial load (N) external spring			9,9	10,8	10,8	7,9	19,7	39,3	39,3
Final load (N) compressed load			26,5	22,6	22,6	49,1	53,0	106,0	106,0

(stroke 0-40 mm)

Microbore cylinders ISO 6431 - 1280 series "MIR"			Bore						
	Front spring	Rear spring	Ø 8	Ø 10	Ø 12	Ø 16	Ø 20	Ø 25	Ø 32
Initial load (N) external spring			2,2	2,2	4,0	7,5	11,0	16,5	23,0
Final load (N) compressed load			4,2	4,2	8,7	21,0	22,0	30,7	30,7

(stroke 0-50 mm)

Cylinders ISO 15552 - 1319-20-21 series			Bore					
	Front spring	Rear spring	Ø 32	Ø 40	Ø 50	Ø 63	Ø 80	Ø 100
Initial load (N) external spring			17,2	24,6	51,0	51,0	98,1	98,1
Final load (N) compressed load			41,7	83,4	114,8	114,8	194,2	194,2

(stroke 0-50 mm)

Short stroke compact cylinders			Bore							
	Front spring	Rear spring	Ø 20	Ø 25	Ø 32	Ø 40	Ø 50	Ø 63	Ø 80	Ø 100
Initial load (N) external spring			7,9	9,9	34,4	34,4	50,1	54,0	117,7	108,9
Final load (N) compressed load			27,5	26,5	59,9	63,8	79,5	85,4	157,0	134,4

(stroke 0-10 mm)

"Europe" Compact cylinders			Bore									
	Front spring	Rear spring	Ø 12	Ø 16	Ø 20	Ø 25	Ø 32	Ø 40	Ø 50	Ø 63	Ø 80	Ø 100
Initial load (N) external spring			3,9	4,4	4,9	9,8	12,3	16,7	27,5	37,3	59,4	101,3
Final load (N) compressed load			9,3	17,7	18,1	25,5	34,3	44,1	51,0	63,8	99,4	141,9

(Ø12 stroke 0-10 mm - Ø16, 100 stroke 0-25 mm)

Cylinder nuts recommended tightening torque	
Bore size	Torque (Nm)
Ø 32	8
Ø 40	8
Ø 50	16
Ø 63	16
Ø 80	22
Ø 100	22
Ø 125	30
Ø 160	85
Ø 200	85

# Measure and conversion units

## International system of units - table

Size	Name	Symbol
Lenght	Meter	m
Area	square meter	m <sup>2</sup>
Volume	cubic meter	m <sup>3</sup>
Force	Newton	N
Mass	kilogram	Kg
Pressure	Pascal	Pa (N/m <sup>2</sup> )
Work and Energy	Joullle	J (Nm)
Power	Watt	W (J/s)
Time	Second	s
Speed	meter / second	m/s
Acceleration	meter / second <sup>2</sup>	m/s <sup>2</sup>
Flow rate	meter / second <sup>3</sup>	m <sup>3</sup> /s
Temperature	Kelvin	°K
Frequency	Hertz	Hz (1/s)
Electric current	Ampere	A
Voltage	Volt	V (W/A)
Electrical resistance	Ohm	Ω (V/A)
Electric power	Volt Ampere	VA (VA)

## Measure and conversion units

Lenght	Centimetre (cm)	Meter (m)	Inch (In)	Foot (ft)	Yard (yd)
1 Meter (m)	100	1	39,37	3,281	1,094
1 Inch (In)	2,54	2,54x10 <sup>-2</sup>	1	8,33x10 <sup>-2</sup>	0,028
1 Foot (ft)	30,48	0,3048	12	1	0,333
1 Yard (yd)	91,44	0,9144	36	3	1

Area	Square centimetre (cm <sup>2</sup> )	Square meter (m <sup>2</sup> )	Square inch (sq in)	Square foot (sq ft)	Square yard (sq yd)
1 Square centimetre (cm <sup>2</sup> )	1	1x10 <sup>-4</sup>	0,155	1,08x10 <sup>-3</sup>	1,2x10 <sup>-4</sup>
1 Square meter (m <sup>2</sup> )	1x10 <sup>4</sup>	1	1.550	10,764	1,2
1 Square inch (sq in)	6,452	6,45x10 <sup>-4</sup>	1	6,95x10 <sup>-3</sup>	7,72x10 <sup>-4</sup>
1 Square foot (sq ft)	929	9,29x10 <sup>-2</sup>	144	1	0,111
1 Square yard (sq yd)	8.361	0,8361	1.296	9	1

Volume	Litre (l=dm <sup>3</sup> )	Cubic metre (m <sup>3</sup> )	Cubic inch (cu in)	Cubic foot (cu ft)	Gallon (gal-USA)	Gallon (gal-GB)
1 Liter (l) = 1dm <sup>3</sup>	1	1x10 <sup>-3</sup>	61,02	3,53x10 <sup>-2</sup>	0,2642	0,22
1 Cubic meter (m <sup>3</sup> )	1.000	1	6,102x10 <sup>4</sup>	35,31	264,2	220
1 Cubic inch (cu in)	1,64x10 <sup>-2</sup>	1,64x10 <sup>-5</sup>	1	5,8x10 <sup>-4</sup>	4,33x10 <sup>-3</sup>	3,6x10 <sup>-3</sup>
1 Cubic foot (cu ft)	28,317	2,83x10 <sup>-2</sup>	1.728	1	7,48	6,23
1 Gallon (gal -USA)	3,785	3,79x10 <sup>-3</sup>	231	0,1337	1	0,8327
1 Gallon (gal -GB)	4,546	4,55x10 <sup>-3</sup>	277,4	0,1605	1,2	1



Mass (Weight)	Kilogram (Kg)	Pound (lb)	Hundred-weight USA	Hundred-weight GB
1 Kilogram (Kg)	1	2,205	1,102x10 <sup>-3</sup>	9,842x10 <sup>-4</sup>
1 Pound (lb)	0,4536	1	5x10 <sup>-4</sup>	4,464x10 <sup>-4</sup>
1 Hundred-weight USA	907,2	2.000	1	0,8929
1 Hundred-weight GB	1.016	2.240	1,12	1

Force	Newton (N)	Kilopound (kgp)	Poundal (pdl)
1 Newton (N)	1	0,102	7,23
1 Kilopound (kgp)	9,807	1	70,93
1 Poundal (pdl)	0,1383	0,0141	1

Pressure	Pascal (Pa)	Bar (bar)	Poundal/pollice <sup>2</sup> (psi)	Technical atmosphere (at=kg/cm <sup>2</sup> )	Atmosphere (atm)	Column of Mercury (mmHg = Torr)	Column of water (mH <sub>2</sub> O)
1 Pascal (Pa)	1	1x10 <sup>-5</sup>	1,45x10 <sup>-4</sup>	1,02x10 <sup>-5</sup>	9,87x10 <sup>-6</sup>	7,5x10 <sup>-3</sup>	1,02x10 <sup>-4</sup>
1 Bar (bar)	1x10 <sup>5</sup>	1	14,50	1,02	0,9869	750	10,2
1 Poundal/pollice <sup>2</sup> (psi)	6.895	0,069	1	7,03x10 <sup>-2</sup>	0,06805	51,72	0,703
1 Technical atmosphere (at=kg/cm <sup>2</sup> )	9,807x10 <sup>4</sup>	0,9807	14,22	1	0,9678	735,6	10
1 Atmosphere (atm)	1,013x10 <sup>5</sup>	1,013	14,70	1,033	1	760	10,33
1 millimetre of mercury (mmHg = Torr)	133,32	1,34x10 <sup>-3</sup>	1,934x10 <sup>-2</sup>	1,36x10 <sup>-3</sup>	1,316x10 <sup>-3</sup>	1	1,36x10 <sup>-2</sup>
1 Metre of water (mH <sub>2</sub> O)	9.810	9,81x10 <sup>-2</sup>	1,423	0,1	9,682x10 <sup>-2</sup>	73,6	1

Work and Energy	Kilocalorie (kcal)	Kilogrammetre (kgm)	Kilowatt (kWh)	Horse power/hr (Hph) non Metric	Joule (J)
1 Kilocalorie (kcal)	1	427	1,163x10 <sup>-3</sup>	1,561x10 <sup>-3</sup>	4.190
1 Kilogrammeter (kgm)	2,34x10 <sup>-3</sup>	1	2,724x10 <sup>-6</sup>	3,653x10 <sup>-6</sup>	9,806
1 Kilowatt-hour (kWh)	860	367.122	1	1,341	3,6x10 <sup>5</sup>
1 Horsepower/hour-non metric (hph)	641	273.761	0,7457	1	2,685x10 <sup>6</sup>
1 Joule (J)	2,39x10 <sup>-4</sup>	0,102	2,78x10 <sup>-7</sup>	3,725x10 <sup>-7</sup>	1

Temperature	Kelvin (K)	Celsius (°C)	Fahrenheit (°F)
Kelvin (K)	/	K-273 = °C	(K-273)x1,8 = °F
Celsius (°C)	°C+273 = K	/	(°Cx1,8)+32 = °F
Fahrenheit (°F)	273+[(°F-32):1,8] = K	(°F-32):1,8 = °C	/

APPENDIX  
A

ISO metric thread UNI 4535-64

Coarse ISO metric thread			
Thread	Pitch (mm)	Ø Drilling (mm)	Ø Drill (mm)
M 1,6	0,35	1,321	1,20
M 1,8	0,35	1,521	1,45
M 2	0,40	1,679	1,60
M 2,2	0,45	1,838	1,75
M 2,5	0,45	2,138	2,05
M 3	0,50	2,599	2,5
M 3,5	0,60	3,010	2,9
M 4	0,70	3,422	3,3
M 4,5	0,75	3,878	3,7
M 5	0,80	4,334	4,2
M 6	1	5,153	5
M 7	1	6,153	6
M 8	1,25	6,912	6,8
M 9	1,25	7,912	7,8
M 10	1,5	8,676	8,5
M 11	1,5	9,676	9,5
M 12	1,75	10,441	10,2
M 14	2	12,210	12
M 16	2	14,210	14
M 18	2,5	15,744	15,5
M 20	2,5	17,744	17,5
M 22	2,5	19,744	19,5
M 24	3	21,252	21
M 27	3	24,252	24
M 30	3,5	26,771	26,5
M 33	3,5	29,771	29,5
M 36	4	32,270	32
M 39	4	35,270	35
M 42	4,5	37,799	37,5
M 45	4,5	40,799	40,5
M 48	5	43,297	43
M 52	5	47,297	47
M 56	5,5	50,796	50,5
M 60	5,5	54,796	54,5
M 64	6	58,305	58
M 68	6	62,305	62

Fine ISO metric thread			
Thread	Pitch (mm)	Ø Drilling (mm)	Ø Drill (mm)
M 3	0,35	2,721	2,65
M 4	0,50	3,599	3,5
M 5	0,50	4,599	4,5
M 6	0,75	5,378	5,2
M 7	0,75	6,378	6,2
M 8	0,75	7,378	7,2
M 8	1	7,153	7
M 9	1	8,153	8
M 10	0,75	9,378	9,2
M 10	1	9,153	9
M 10	1,25	8,912	8,8
M 11	1	10,153	10
M 12	1	11,153	11
M 12	1,25	10,912	10,8
M 12	1,5	10,676	10,5
M 14	1	13,153	13
M 14	1,25	12,912	12,8
M 14	1,5	12,676	12,5
M 15	1	14,153	14
M 15	1,5	13,676	13,5
M 16	1	15,153	15
M 16	1,5	14,676	14,5
M 18	1	17,153	17
M 18	1,5	16,676	16,5
M 18	2	16,210	16
M 20	1	19,153	19
M 20	1,5	18,676	18,5
M 20	2	18,210	18
M 22	1	21,153	21
M 22	1,5	20,676	20,5
M 21	2	20,210	20
M 24	1	23,153	23
M 24	1,5	22,676	22,5
M 24	2	22,210	22
M 24	1	24,153	24
M 25	1,5	23,676	23,5
M 26	1,5	24,676	24,5
M 27	1,5	25,676	25,5
M 27	2	25,210	25
M 28	1,5	26,676	26,5
M 30	1,5	28,676	28,5
M 30	2	28,210	28
M 32	1,5	30,676	30,5
M 33	2	31,210	31
M 35	1,5	33,676	33,5
M 36	1,5	34,676	34,5
M 36	2	34,210	34
M 36	3	33,252	33
M 38	1,5	36,676	36,5
M 39	3	36,252	36
M 40	1,5	38,676	38,5
M 42	1,5	40,676	40,5
M 45	1,5	43,676	43,5
M 50	1,5	48,676	48,5



**GAS thread**

«G» UNI 338-66			
Thread	Ø External (mm)	Ø Drilling (mm)	Ø Drill point (mm)
G 1/8" - 28	9,73	8,68	8,70
G 1/4" - 19	13,16	11,62	11,75
G 3/8" - 19	16,66	15,12	15,25
G 1/2" - 14	20,95	18,86	19,00
G 5/8" - 14	22,91	20,82	21,00
G 3/4" - 14	26,44	24,35	24,50
G 7/8" - 14	30,20	28,11	28,25
G 1" - 11	33,25	30,59	30,50
G 1 1/8" - 11	37,90	35,24	35,50
G 1 1/4" - 11	41,91	39,25	39,50
G 1 3/8" - 11	44,32	41,66	41,50
G 1 1/2" - 11	47,80	45,14	45,00
G 1 5/8" - 11	51,32	48,67	48,50
G 1 3/4" - 11	53,75	51,08	51,00
G 2" - 11	59,61	56,95	57,00
G 2 1/4" - 11	65,71	63,05	63,00
G 2 1/2" - 11	75,18	72,52	72,50
G 2 3/4" - 11	81,53	78,87	79,00
G 3" - 11	87,88	85,22	85,50
G 3 1/4" - 11	93,98	91,32	91,50
G 3 1/2" - 11	100,33	97,67	97,50
G 3 3/4" - 11	106,68	104,02	104,00
G 4" - 11	113,03	110,37	110,50

«Gc» UNI 339-66			
Thread	Ø External (mm)	Ø Drilling (mm)	Ø Drill point (mm)
Gc 1/8" - 28	8,5	4,9	3,1
Gc 1/4" - 19	11,5	7,3	4,7
Gc 3/8" - 19	15,0	7,7	5,1
Gc 1/2" - 14	18,5	10,0	6,4
Gc 3/4" - 14	23,5	11,3	7,7
Gc 1" - 11	30,0	12,7	8,1
Gc 1 1/4" - 11	38,0	15,0	10,4
Gc 1 3/8" - 11	41,0	15,0	10,4
Gc 1 1/2" - 11	44,5	15,0	10,4
Gc 2" - 11	56,0	18,2	13,6
Gc 2 1/2" - 11	72,0	21,0	14,0
Gc 3" - 11	85,0	24,1	17,1
		<b>max</b>	<b>min</b>

A

APPENDIX



# Alphanumeric index

## Air distribution

Coding	Series	Family	Page
1001...	1000	ISO 5599-1 valves & solenoid valves	308
1001.52...	1000	ISO 5599-1 valves & solenoid valves	304
1001.53...	1000	ISO 5599-1 valves & solenoid valves	304
1002...	1000	ISO 5599-1 valves & solenoid valves	308
1002.52...	1000	ISO 5599-1 valves & solenoid valves	306
1002.53...	1000	ISO 5599-1 valves & solenoid valves	306
1011.52...	1000	ISO 5599-1 valves & solenoid valves	309
1011.52...	1000	ISO 5599-1 valves & solenoid valves	310
1011.53...	1000	ISO 5599-1 valves & solenoid valves	309
1011.53...	1000	ISO 5599-1 valves & solenoid valves	310
1012.52...	1000	ISO 5599-1 valves & solenoid valves	311
1012.52...	1000	ISO 5599-1 valves & solenoid valves	312
1012.53...	1000	ISO 5599-1 valves & solenoid valves	311
1012.53...	1000	ISO 5599-1 valves & solenoid valves	312
1013.52...	1000	ISO 5599-1 valves & solenoid valves	313-314
1013.53...	1000	ISO 5599-1 valves & solenoid valves	313-314
104...0.1...	104	Spool valves & solenoid valves	2
104...11.1...	104	Spool valves & solenoid valves	11
104...2.1	104	Spool valves & solenoid valves	9
104...2.1/1...	104	Spool valves & solenoid valves	9
104...3.1...	104	Spool valves & solenoid valves	9
104...6.22/...	104	Spool valves & solenoid valves	2
104...6.23...	104	Spool valves & solenoid valves	4
104...6.25...	104	Spool valves & solenoid valves	5
104...6.31...	104	Spool valves & solenoid valves	3
104...F1.6.27...	104	Spool valves & solenoid valves	7
104...F1.6.28...	104	Spool valves & solenoid valves	8
104...F1.6.30...	104	Spool valves & solenoid valves	6
104.00	104	Spool valves & solenoid valves	10
104.02	104	Spool valves & solenoid valves	10
104.11	104	Spool valves & solenoid valves	10
104.2...	104	Spool valves & solenoid valves	10
104.3.1	104	Spool valves & solenoid valves	10
104.6...	104	Spool valves & solenoid valves	10
104.F	104	Spool valves & solenoid valves	10
105...0...	105	Spool valves & solenoid valves	13
105...11...	105	Spool valves & solenoid valves	20
105...2...	105	Spool valves & solenoid valves	13-14
105...3...	105	Spool valves & solenoid valves	14
105...4...	105	Spool valves & solenoid valves	14
105...5...	105	Spool valves & solenoid valves	15

Coding	Series	Family	Page
105...6...	105	Spool valves & solenoid valves	15-16-17-19
105...7...	105	Spool valves & solenoid valves	17
105...8...	105	Spool valves & solenoid valves	18
105...9...	105	Spool valves & solenoid valves	18
1051.52...	1000	ISO 5599-1 valves & solenoid valves	305
1051.53...	1000	ISO 5599-1 valves & solenoid valves	305
1052.52...	1000	ISO 5599-1 valves & solenoid valves	307
1052.53...	1000	ISO 5599-1 valves & solenoid valves	307
110T...	1100	ISO 5599-1 valves & solenoid valves	316-317-318-319
1111.52...	1000 M12	ISO 5599-1 valves & solenoid valves	321
1111.53...	1000 M12	ISO 5599-1 valves & solenoid valves	322
1112.52...	1000 M12	ISO 5599-1 valves & solenoid valves	323
1112.53...	1000 M12	ISO 5599-1 valves & solenoid valves	324
1113.52...	1000 M12	ISO 5599-1 valves & solenoid valves	325-326
1113.53...	1000 M12	ISO 5599-1 valves & solenoid valves	326
17522A...	1750-1760	Accessories - Miniaturized proportional pressure regulators	370
17602A...	1750-1760	Accessories - Miniaturized proportional pressure regulators	370
17602B...	1750-1760	Accessories - Miniaturized proportional pressure regulators	370
2100.02...	2100	Spool valves & solenoid valves	136
2100.03...	2100	Spool valves & solenoid valves	134
2100.04...	2100	Spool valves & solenoid valves	136
211...11...	200	Spool valves & solenoid valves	52
211...9...	200	Spool valves & solenoid valves	50
211.53...11...	200	Spool valves & solenoid valves	53
211.53...9...	200	Spool valves & solenoid valves	50-51
2115.52.00...	2100	Spool valves & solenoid valves	124-125
2115.53...	2100	Spool valves & solenoid valves	126
212...11...	200	Spool valves & solenoid valves	46
212...9...	200	Spool valves & solenoid valves	44
212.53...11...	200	Spool valves & solenoid valves	47
212.53...9...	200	Spool valves & solenoid valves	44-45
212/2...11...	200	Spool valves & solenoid valves	48-49
212/2.53...11...	200	Spool valves & solenoid valves	49
2130...	2100	Spool valves & solenoid valves	133-134
2135.52.00...	2100	Spool valves & solenoid valves	127-128
2135.53...	2100	Spool valves & solenoid valves	129
214...10...	200	Spool valves & solenoid valves	43
2141.52.00...	2100	Spool valves & solenoid valves	130-131
2141.53...	2100	Spool valves & solenoid valves	132



Coding	Series	Family	Page
214V...	2100	Spool valves & solenoid valves	133
2230.17	2200	Solenoid valves manifold	426
224...1...	200	Spool valves & solenoid valves	36
224...10...	200	Spool valves & solenoid valves	38
224...11...	200	Spool valves & solenoid valves	41
224...2...	200	Spool valves & solenoid valves	36
224...3...	200	Spool valves & solenoid valves	36
224...8...	200	Spool valves & solenoid valves	37
224...9...	200	Spool valves & solenoid valves	37-38-39
224.53...10...	200	Spool valves & solenoid valves	40
224.53...11...	200	Spool valves & solenoid valves	42
224.53...9...	200	Spool valves & solenoid valves	39-40
2240.00	2200	Solenoid valves manifold	424
2240.00	2200-Sc	Solenoid valves manifold	452
2240.02...	2200	Solenoid valves manifold	424
2240.03...	2200	Solenoid valves manifold	424
2240.08S	2200	Solenoid valves manifold	427
2240.10	2200	Solenoid valves manifold	425
2240.12...	2200	Solenoid valves manifold	424
2240.KD.00	2200	Solenoid valves manifold	426
2240.KT...	2200	Solenoid valves manifold	426
2241.52.00...	2200	Solenoid valves manifold	422
2241.52.00...	2200-Sc	Solenoid valves manifold	449
2241.53.31...	2200	Solenoid valves manifold	423
2241.53.31...	2200-Sc	Solenoid valves manifold	450
2241.62...	2200	Solenoid valves manifold	423
2241.62...	2200-Sc	Solenoid valves manifold	450
224C...	2200	Solenoid valves manifold	425
228...0...	200	Spool valves & solenoid valves	22
228...1...	200	Spool valves & solenoid valves	22
228...10...	200	Spool valves & solenoid valves	29-30-31
228...11...	200	Spool valves & solenoid valves	34-35
228...13...	200	Spool valves & solenoid valves	35
228...2...	200	Spool valves & solenoid valves	22-23
228...27...	200	Spool valves & solenoid valves	23
228...3...	200	Spool valves & solenoid valves	24
228...4...	200	Spool valves & solenoid valves	24
228...5...	200	Spool valves & solenoid valves	25
228...55...	200	Spool valves & solenoid valves	25
228...6...	200	Spool valves & solenoid valves	25-26-27
228...7...	200	Spool valves & solenoid valves	28
228...8...	200	Spool valves & solenoid valves	28
228...9...	200	Spool valves & solenoid valves	29
228.53...10...	200	Spool valves & solenoid valves	33
228.53...11...	200	Spool valves & solenoid valves	35
228.53...9...	200	Spool valves & solenoid valves	31
228.53...99...	200	Spool valves & solenoid valves	32-33
2300...	2300	Solenoid valves manifold	407
2300.16	2300	Solenoid valves manifold	407
2300.16	3000	Solenoid valves manifold	537
2300.25...	2100	Spool valves & solenoid valves	137
2300.25...	2400	Spool valves & solenoid valves	160
2300.25...	2700	ISO15407-2 valves & solenoid valves	377
2300.25...	2200	Solenoid valves manifold	426
2300.25...	2500-F	Solenoid valves manifold	464
2300.25...	2500-T	Solenoid valves manifold	496
2300.25...	2300	Solenoid valves manifold	408
2300.25...	3000	Solenoid valves manifold	538

Coding	Series	Family	Page
2300.44...	3000	Solenoid valves manifold	538
2300.50	2300	Solenoid valves manifold	407
2308...	2300	Solenoid valves manifold	407
230C.42...	2300	Solenoid valves manifold	404-405
230C.53.31...	2300	Solenoid valves manifold	402
230C.62...	2300	Solenoid valves manifold	403-404
2311.03...	2300	Solenoid valves manifold	406
2311.05...	2300	Solenoid valves manifold	406
2312.00	2300	Solenoid valves manifold	406
2317...	2300	Solenoid valves manifold	408
23EC.52.00...	2300	Solenoid valves manifold	401-402
2400...L...	2100	Spool valves & solenoid valves	137-160
2400...L...	2400	Spool valves & solenoid valves	160
2400.00	2400	Spool valves & solenoid valves	159
2400.04.25	2400	Spool valves & solenoid valves	160
2400.09...00	2200-Sc	Solenoid valves manifold	452
2400.15...00	2200-Sc	Solenoid valves manifold	452
2400.15.00	2400	Spool valves & solenoid valves	159
2400.15.02	2400	Spool valves & solenoid valves	160
2400.25...25	2700	ISO15407-2 valves & solenoid valves	377
2400.25...25	2200	Solenoid valves manifold	426
2400.25...25	2500-F	Solenoid valves manifold	464
2400.25...25	2500-T	Solenoid valves manifold	496
2400.37...	2100	Spool valves & solenoid valves	137
2400.37...	2400	Spool valves & solenoid valves	160
2400.37...	2700	ISO15407-2 valves & solenoid valves	377
2400.37...	2200	Solenoid valves manifold	426
2400.37...	2500-F	Solenoid valves manifold	464
2400.37...	2500-T	Solenoid valves manifold	496
2400.37...	3000	Solenoid valves manifold	538
2400.P...	2400	Spool valves & solenoid valves	159
241A.52.00...	2400	Spool valves & solenoid valves	140-141-143
241A.53...	2400	Spool valves & solenoid valves	143
241A.62...	2400	Spool valves & solenoid valves	144
2430...	2400	Spool valves & solenoid valves	150-151
2430.50	2400	Spool valves & solenoid valves	159
243A.52.00...	2400	Spool valves & solenoid valves	145-146-147
243A.53...	2400	Spool valves & solenoid valves	148
243A.62...	2400	Spool valves & solenoid valves	148-149
2440...	2400	Spool valves & solenoid valves	157
2440.50	2400	Spool valves & solenoid valves	159
2445.52.00...	2400	Spool valves & solenoid valves	152-153
2445.62...	2400	Spool valves & solenoid valves	156
244C.52.00...	2400	Spool valves & solenoid valves	154
244C.53...	2400	Spool valves & solenoid valves	155
2530.00	2500-F	Solenoid valves manifold	459
2530.00	2500-T	Solenoid valves manifold	489
2530.01B	2500-F	Solenoid valves manifold	459
2530.01M	2500-F	Solenoid valves manifold	459
2530.02...	2500-F	Solenoid valves manifold	458
2530.03...	2500-F	Solenoid valves manifold	458
2530.08F	2500-F	Solenoid valves manifold	467
2530.10	2500-F	Solenoid valves manifold	459
2530.10.2A	2500-F	Solenoid valves manifold	460
2530.10.4A	2500-F	Solenoid valves manifold	462
2530.12...	2500-F	Solenoid valves manifold	458
2530.17	2500-F	Solenoid valves manifold	464
2530.17	2500-T	Solenoid valves manifold	496



Coding	Series	Family	Page
2531.52.00...	2500-F	Solenoid valves manifold	456
2531.53.31...	2500-F	Solenoid valves manifold	457
2531.62...	2500-F	Solenoid valves manifold	457
2540.02...	2500-T	Solenoid valves manifold	489
2540.03...	2500-T	Solenoid valves manifold	489
2540.08T	2700	ISO15407-2 valves & solenoid valves	380
2540.08T	2500-T	Solenoid valves manifold	499
2540.10	2500-T	Solenoid valves manifold	490
2540.10.2A	2500-T	Solenoid valves manifold	492
2540.10.4A	2500-T	Solenoid valves manifold	494
2540.12...	2500-T	Solenoid valves manifold	489
2540.KD.00	2500-T	Solenoid valves manifold	490
2540.KP01	2500-T	Solenoid valves manifold	490
2540.KT.P	2500-T	Solenoid valves manifold	496
2541.01...	2500-T	Solenoid valves manifold	490
2541.52.00...	2500-T	Solenoid valves manifold	487
2541.53.31...	2500-T	Solenoid valves manifold	488
2541.62...	2500-T	Solenoid valves manifold	488
2544.01...	2500-T	Solenoid valves manifold	490
2546.01...	2500-T	Solenoid valves manifold	490
2548.01...	2500-T	Solenoid valves manifold	490
261 <sup>A</sup> .52.00...	2600	Spool valves & solenoid valves	163-164-165
261 <sup>A</sup> .53...	2600	Spool valves & solenoid valves	166
2630...	2600	Spool valves & solenoid valves	171
263 <sup>A</sup> .52.00...	2600	Spool valves & solenoid valves	167-168-169
263 <sup>A</sup> .52.00...	2600	Spool valves & solenoid valves	169
263 <sup>A</sup> .53...	2600	Spool valves & solenoid valves	170
2640...	2600	Spool valves & solenoid valves	176-177
2645.52.00...	2600	Spool valves & solenoid valves	172-173
264 <sup>C</sup> .52.00...	2600	Spool valves & solenoid valves	174
264 <sup>C</sup> .53...	2600	Spool valves & solenoid valves	175
2740.00	2700	ISO15407-2 valves & solenoid valves	377
2740.01...	2700	ISO15407-2 valves & solenoid valves	376
2740.02...	2700	ISO15407-2 valves & solenoid valves	376
2740.03...	2700	ISO15407-2 valves & solenoid valves	376
2740.17	2700	ISO15407-2 valves & solenoid valves	377
2741.52.00...	2700	ISO15407-2 valves & solenoid valves	374
2741.53.31...	2700	ISO15407-2 valves & solenoid valves	375
2741.62...35...	2700	ISO15407-2 valves & solenoid valves	375
300...	300	Direct operated solenoid valves	204-205
305...	300	Direct operated solenoid valves	194-195
305.11...	300	Direct operated solenoid valves	198
305.M...	300	Direct operated solenoid valves	198
305.M1	300	Direct operated solenoid valves	197
305.M1/1	300	Direct operated solenoid valves	197
305.M1/9	300	Direct operated solenoid valves	197
305.M5/B	300	Direct operated solenoid valves	200
3115...	3000	Solenoid valves manifold	528
3115.52.00...	3000	Solenoid valves manifold	524-526
3115.53.00...	3000	Solenoid valves manifold	525-527
3115.62.00...	3000	Solenoid valves manifold	525-527
3130.17	3000	Solenoid valves manifold	538
3140...	3000	Solenoid valves manifold	536
3140.10	3000	Solenoid valves manifold	537
3141.52.00...	3000	Solenoid valves manifold	534
3141.53.00...	3000	Solenoid valves manifold	535
3141.62.00...	3000	Solenoid valves manifold	535
3145...	3000	Solenoid valves manifold	539

Coding	Series	Family	Page
315...	300	Direct operated solenoid valves	186
345.M1	300	Direct operated solenoid valves	197
345.M1/1	300	Direct operated solenoid valves	197
345.M1/9	300	Direct operated solenoid valves	197
345.M5/B	300	Direct operated solenoid valves	200
354...	300	Direct operated solenoid valves	186
355...	300	Direct operated solenoid valves	186
355.M1	300	Direct operated solenoid valves	197
355.M1/1	300	Direct operated solenoid valves	197
355.M1/9	300	Direct operated solenoid valves	197
355.M5/B	300	Direct operated solenoid valves	200
35M...	300	Direct operated solenoid valves	188
35S...	300	Direct operated solenoid valves	189
371...	300	Direct operated solenoid valves	18
395...	300	Direct operated solenoid valves	183
395.00	300	Direct operated solenoid valves	180-181
411...0.0...	400	Spool valves & solenoid valves	108
411...0.1...	400	Spool valves & solenoid valves	107
411...0.12...	400	Spool valves & solenoid valves	107
411.53...0...	400	Spool valves & solenoid valves	108
412/2...0.0...	400	Spool valves & solenoid valves	106
412/2...0.1...	400	Spool valves & solenoid valves	105
412/2...0.12...	400	Spool valves & solenoid valves	105
412/2.53...0.0...	400	Spool valves & solenoid valves	106
452...0.0...	400	Spool valves & solenoid valves	102
452...0.1...	400	Spool valves & solenoid valves	101
452...0.12...	400	Spool valves & solenoid valves	101
452.53...0...	400	Spool valves & solenoid valves	102
452/1...0.0...	400	Spool valves & solenoid valves	104
452/1...0.1...	400	Spool valves & solenoid valves	103
452/1...0.12...	400	Spool valves & solenoid valves	103
452/1.53...0...	400	Spool valves & solenoid valves	104
464...0.0...	400	Spool valves & solenoid valves	97
464...0.1...	400	Spool valves & solenoid valves	97
464...0.12...	400	Spool valves & solenoid valves	97
464.53...0...	400	Spool valves & solenoid valves	98
464/1...0.0...	400	Spool valves & solenoid valves	99
464/1...0.1...	400	Spool valves & solenoid valves	99
464/1...0.12...	400	Spool valves & solenoid valves	99
464/1.53...0...	400	Spool valves & solenoid valves	100
468...0.0...	400	Spool valves & solenoid valves	91
468...0.1...	400	Spool valves & solenoid valves	91
468...0.12...	400	Spool valves & solenoid valves	91
468.53...0...	400	Spool valves & solenoid valves	92
468/1...0.0...	400	Spool valves & solenoid valves	93
468/1...0.1...	400	Spool valves & solenoid valves	92
468/1...0.12...	400	Spool valves & solenoid valves	92
468/1.53...0...	400	Spool valves & solenoid valves	93
488...	400	Spool valves & solenoid valves	96
488...0.0...	400	Spool valves & solenoid valves	94
488...0.1...	400	Spool valves & solenoid valves	94
488...0.12...	400	Spool valves & solenoid valves	94
488.53...0...	400	Spool valves & solenoid valves	95
50...	50-T50	Accessories - Blocking valves	350-351
5030.M12	3000	Solenoid valves manifold	552
5130..	3000	Solenoid valves manifold	547-548-550-551
514/N...	514/N	"Namur" valves and solenoid valves	284





Coding	Series	Family	Page
5200.08	2300	Solenoid valves manifold	418
5222.08S	2200	Solenoid valves manifold	445
5225.08F	2500-F	Solenoid valves manifold	481
5225.08T	2700	ISO15407-2 valves & solenoid valves	393
5225.08T	2500-T	Solenoid valves manifold	513
5225.12T	2700	ISO15407-2 valves & solenoid valves	394
5225.12T	2500-T	Solenoid valves manifold	514
5225.2 _ . _ _ T	2700	ISO15407-2 valves & solenoid valves	395
5225.25F	2500-F	Solenoid valves manifold	482
5225.2C.00F	2500-F	Solenoid valves manifold	483
5225.2C.00T	2500-T	Solenoid valves manifold	515
5225.2C.01F	2500-F	Solenoid valves manifold	483
5225.2C.01T	2500-T	Solenoid valves manifold	515
5225.2P . 0 _ T	2700	ISO15407-2 valves & solenoid valves	396
5225.2P . 1 _ T	2700	ISO15407-2 valves & solenoid valves	397
5225.2P00T	2500-T	Solenoid valves manifold	516
5225.2P10T	2500-T	Solenoid valves manifold	517
5225.2P01T	2500-T	Solenoid valves manifold	516
5225.2P11T	2500-T	Solenoid valves manifold	517
5225.2T.00F	2500-F	Solenoid valves manifold	483
5225.2T.00T	2500-T	Solenoid valves manifold	515
5225.2T.01F	2500-F	Solenoid valves manifold	483
5225.2T.01T	2500-T	Solenoid valves manifold	515
5230..	3000	Solenoid valves manifold	546-548-549
5300.T08	2700	ISO15407-2 valves & solenoid valves	398
5300.T08	2200	Solenoid valves manifold	446
5300.T08	2500-F	Solenoid valves manifold	484
5300.T08	2500-T	Solenoid valves manifold	518
5300.T12	2700	ISO15407-2 valves & solenoid valves	398
5300.T12	2200	Solenoid valves manifold	446
5300.T12	2500-F	Solenoid valves manifold	484
5300.T12	2500-T	Solenoid valves manifold	518
5308A.M03.00	2700	ISO15407-2 valves & solenoid valves	398
5308A.M03.00	2200	Solenoid valves manifold	446
5308A.M03.00	2500-F	Solenoid valves manifold	484
5308A.M03.00	2500-T	Solenoid valves manifold	518
5312A.F04.00	2700	ISO15407-2 valves & solenoid valves	398
5312A.F04.00	2200	Solenoid valves manifold	446
5312A.F04.00	2500-F	Solenoid valves manifold	484
5312A.F04.00	2500-T	Solenoid valves manifold	518
5312A.F05.00	2700	ISO15407-2 valves & solenoid valves	398
5312A.F05.00	2200	Solenoid valves manifold	446
5312A.F05.00	2500-F	Solenoid valves manifold	484
5312A.F05.00	2500-T	Solenoid valves manifold	518
5312A.M05.00	2700	ISO15407-2 valves & solenoid valves	398
5312A.M05.00	2700	ISO15407-2 valves & solenoid valves	398
5312A.M05.00	2200	Solenoid valves manifold	446
5312A.M05.00	2500-F	Solenoid valves manifold	484
5312A.M05.00	2500-F	Solenoid valves manifold	484
5312A.M05.00	2500-T	Solenoid valves manifold	518
5312A.M05.00	2500-T	Solenoid valves manifold	518
5312B.F05.00	2700	ISO15407-2 valves & solenoid valves	398
5312B.F05.00	2200	Solenoid valves manifold	446
5312B.F05.00	2500-F	Solenoid valves manifold	484
5312B.F05.00	2500-T	Solenoid valves manifold	518
5312B.M05.00	2700	ISO15407-2 valves & solenoid valves	398
5312B.M05.00	2200	Solenoid valves manifold	446
5312B.M05.00	2500-F	Solenoid valves manifold	484

Coding	Series	Family	Page
5312B.M05.00	2500-T	Solenoid valves manifold	518
5312D.M04.00	2700	ISO15407-2 valves & solenoid valves	398
5312D.M04.00	2200	Solenoid valves manifold	446
5312D.M04.00	2500-F	Solenoid valves manifold	484
5312D.M04.00	2500-T	Solenoid valves manifold	518
5322.32S	2200	Solenoid valves manifold	438
5323.22	2300	Solenoid valves manifold	417
5325.32F	2500-F	Solenoid valves manifold	475
5325.32T	2700	ISO15407-2 valves & solenoid valves	387
5325.32T	2500-T	Solenoid valves manifold	507
5330.64...	3000	Solenoid valves manifold	543
5422.32S	2200	Solenoid valves manifold	437
5423.22	2300	Solenoid valves manifold	416
5425.32F	2500-F	Solenoid valves manifold	474
5425.32T	2700	ISO15407-2 valves & solenoid valves	386
5425.32T	2500-T	Solenoid valves manifold	506
551.11...	55	Accessories - Function fittings	355
551.12...	55	Accessories - Function fittings	356
551.13...	55	Accessories - Function fittings	567
551.141...	55	Accessories - Function fittings	359
551.151...	55	Accessories - Function fittings	359
551.161...	55	Accessories - Function fittings	360
551.178...	55	Accessories - Function fittings	360
551.181...	55	Accessories - Function fittings	361
551.1F...	55	Accessories - Function fittings	362
551.1G...	55	Accessories - Function fittings	364
551.1H...	55	Accessories - Function fittings	366
551.22...	55	Accessories - Function fittings	356
551.23...	55	Accessories - Function fittings	358
551.281...	55	Accessories - Function fittings	361
551.2F...	55	Accessories - Function fittings	363
551.2G...	55	Accessories - Function fittings	365
551.2H...	55	Accessories - Function fittings	366
55116	55	Accessories - Function fittings	367
55150	55	Accessories - Function fittings	367
55160	55	Accessories - Function fittings	367
551K...	55	Accessories - Function fittings	368
551KD...	55	Accessories - Function fittings	367
551KG...	55	Accessories - Function fittings	368
551KL1	55	Accessories - Function fittings	368
551KUU	55	Accessories - Function fittings	368
5522.32S	2200	Solenoid valves manifold	436
5523.22	2300	Solenoid valves manifold	415
5525.32F	2500-F	Solenoid valves manifold	473
5525.32T	2700	ISO15407-2 valves & solenoid valves	385
5525.32T	2500-T	Solenoid valves manifold	505
5530.64...	3000	Solenoid valves manifold	542
5722.32S.EC	2200	Solenoid valves manifold	439
5722.32S.EI	2200	Solenoid valves manifold	441
5722.32S.MT	2200	Solenoid valves manifold	443
5722.32S.PL	2200	Solenoid valves manifold	442
5722.32S.PN	2200	Solenoid valves manifold	440
5725.32F.EC	2500-F	Solenoid valves manifold	476
5725.32F.EI	2500-F	Solenoid valves manifold	478
5725.32F.MT	2500-F	Solenoid valves manifold	480
5725.32F.PL	2500-F	Solenoid valves manifold	479
5725.32F.PN	2500-F	Solenoid valves manifold	477
5725.32T.EC	2700	ISO15407-2 valves & solenoid valves	388



Coding	Series	Family	Page
5725.32T.EC	2500-T	Solenoid valves manifold	508
5725.32T.EI	2700	ISO15407-2 valves & solenoid valves	390
5725.32T.EI	2500-T	Solenoid valves manifold	510
5725.32T.MT	2700	ISO15407-2 valves & solenoid valves	392
5725.32T.MT	2500-T	Solenoid valves manifold	512
5725.32T.PL	2700	ISO15407-2 valves & solenoid valves	391
5725.32T.PL	2500-T	Solenoid valves manifold	511
5725.32T.PN	2700	ISO15407-2 valves & solenoid valves	389
5725.32T.PN	2500-T	Solenoid valves manifold	509
5730.128...	3000	Solenoid valves manifold	544
5822.32S	2200	Solenoid valves manifold	444
5830.64...	3000	Solenoid valves manifold	545
6.01.05...	600	Accessories-Pneumatic circuit devices	329-330
6.01.05.180	600	Accessories-Pneumatic circuit devices	330
6.01.05.180/2	600	Accessories-Pneumatic circuit devices	330
6.01.05.90	600	Accessories-Pneumatic circuit devices	329
6.01.05.90/2	600	Accessories-Pneumatic circuit devices	329
6.01.05/2	600	Accessories-Pneumatic circuit devices	329
6.01.12	600	Accessories-Pneumatic circuit devices	331
6.01.12/1N	600	Accessories-Pneumatic circuit devices	331
6.01.14/1	600	Accessories-Pneumatic circuit devices	331
6.01.14/1N	600	Accessories-Pneumatic circuit devices	331
6.01.14N	600	Accessories-Pneumatic circuit devices	331
6.01.18...	600	Accessories-Pneumatic circuit devices	330
6.01.18/...	600	Accessories-Pneumatic circuit devices	330
6.01.305...	600	Accessories-Pneumatic circuit devices	328
6.01.315...	600	Accessories-Pneumatic circuit devices	328
6.01.34	600	Accessories-Pneumatic circuit devices	331
6.01.45...	600	Accessories-Pneumatic circuit devices	329
6.02...	600	Accessories-Pneumatic circuit devices	332
6.03...	600	Accessories-Pneumatic circuit devices	332
6.04...	600	Accessories-Pneumatic circuit devices	333
6.04.../1	600	Accessories-Pneumatic circuit devices	333
6.04.04	600	Accessories-Pneumatic circuit devices	333
6.04.04/1	600	Accessories-Pneumatic circuit devices	334
6.05...	600	Accessories-Pneumatic circuit devices	334
6.06.1	600	Accessories-Pneumatic circuit devices	334
6.07...	600	Accessories-Pneumatic circuit devices	335
6.07.18...	600	Accessories-Pneumatic circuit devices	335
6.08.../4	600	Accessories-Pneumatic circuit devices	335
6.08.../8	600	Accessories-Pneumatic circuit devices	336
6.09.12...	600	Accessories-Pneumatic circuit devices	336
6.09.14...	600	Accessories-Pneumatic circuit devices	336
6.10.14...	600	Accessories-Pneumatic circuit devices	339
6.10.18...	600	Accessories-Pneumatic circuit devices	338
6.11...	600	Accessories-Pneumatic circuit devices	337
6.13.00	600	Accessories-Pneumatic circuit devices	340
771...	700	Poppet valves and solenoid valves	215
771/V...	700	Poppet valves and solenoid valves	216
772...	700	Poppet valves and solenoid valves	211
772/V...	700	Poppet valves and solenoid valves	212
773...	700	Poppet valves and solenoid valves	213
773/V...	700	Poppet valves and solenoid valves	214
776...	700	Poppet valves and solenoid valves	217-218
776/V...	700	Poppet valves and solenoid valves	219-220
779...	700	Poppet valves and solenoid valves	209
779/V...	700	Poppet valves and solenoid valves	210
805...	800	Spool valves & solenoid valves	71

Coding	Series	Family	Page
805...0...	800	Spool valves & solenoid valves	70
805...11...	800	Spool valves & solenoid valves	69
808...	800	Spool valves & solenoid valves	76
808...0...	800	Spool valves & solenoid valves	74
808...11...	800	Spool valves & solenoid valves	72
808.53...0...	800	Spool valves & solenoid valves	75
808.53...11...	800	Spool valves & solenoid valves	73
888...	888	Spool valves & solenoid valves	83
8880.32...	888	Spool valves & solenoid valves	78
8880.52.00.35...	888	Spool valves & solenoid valves	78-79
8880.52.00.39...	888	Spool valves & solenoid valves	78
8880.53...	888	Spool valves & solenoid valves	79
8880E.32...	888	Spool valves & solenoid valves	79
8880E.32.00.35...	888	Spool valves & solenoid valves	80
8880E.52.00.35...	888	Spool valves & solenoid valves	80
8880E.52.00.39...	888	Spool valves & solenoid valves	80
8880E.53...	888	Spool valves & solenoid valves	81
8883...	888	Spool valves & solenoid valves	84
8884.32.00.39...	888	Spool valves & solenoid valves	82
8884.52.00.35...	888	Spool valves & solenoid valves	82
8884.52.00.39...	888	Spool valves & solenoid valves	81
8884.53...35...	888	Spool valves & solenoid valves	82
888M...	888	Spool valves & solenoid valves	85
900.005	900	Accessories -Complementary valves	347
900.14.7	900	Accessories -Complementary valves	346
900.18...	900	Accessories -Complementary valves	342-343
900.18...	900	Accessories -Complementary valves	347
900.18.10	900	Accessories -Complementary valves	344
900.18.11	900	Accessories -Complementary valves	344
900.18.9	900	Accessories -Complementary valves	344
900.19.01	900	Accessories -Complementary valves	348
900.32.6	900	Accessories -Complementary valves	346
900.52...	900	Accessories -Complementary valves	345-346
900.52.1.1	900	Accessories -Complementary valves	343
CMP1E...	2200-Sc	Solenoid valves manifold	451
CMP9E...	2200-Sc	Solenoid valves manifold	451
F3105...	F300	Poppet valves and solenoid valves	256
F3106...	F300	Poppet valves and solenoid valves	257-258
F3107...	F300	Poppet valves and solenoid valves	259-260
F3108...	F300	Poppet valves and solenoid valves	272
F3110...	F300	Poppet valves and solenoid valves	261
F3111...	F300	Poppet valves and solenoid valves	262
F3119...	F300	Poppet valves and solenoid valves	273-274
F3119W...	F300	Poppet valves and solenoid valves	275
F3177...	F300	Poppet valves and solenoid valves	263
F3206...	F300	Poppet valves and solenoid valves	264-265
F3207...	F300	Poppet valves and solenoid valves	266
F3210...	F300	Poppet valves and solenoid valves	267
F3211...	F300	Poppet valves and solenoid valves	268
F3277...	F300	Poppet valves and solenoid valves	269
F3310...	F300	Poppet valves and solenoid valves	270
F3331...	F300	Poppet valves and solenoid valves	271
FX3106...	F300	Poppet valves and solenoid valves	276-277
FX3107	F300	Poppet valves and solenoid valves	278
FX3110	F300	Poppet valves and solenoid valves	279
FX3177	F300	Poppet valves and solenoid valves	280
M2...	300	Direct operated solenoid valves	192-193
M3...	300	Direct operated solenoid valves	201



Coding	Series	Family	Page
M4...	300	Direct operated solenoid valves	201
M5/B	300	Direct operated solenoid valves	200
M514...00...	514	"Namur" valves and solenoid valves	291-292-293-294-295
M514.92...	514	"Namur" valves and solenoid valves	296
M515.52...	515	"Namur" valves and solenoid valves	298-299-300-301-302
MB...	300	Direct operated solenoid valves	193-199
MC...	300	Direct operated solenoid valves	201
MG...	F300	Poppet valves and solenoid valves	281
MI...	F300	Poppet valves and solenoid valves	281
MK...	F300	Poppet valves and solenoid valves	281
MM7	300	Direct operated solenoid valves	192
N33...	300	Direct operated solenoid valves	185
N34...	300	Direct operated solenoid valves	185
N36...	300	Direct operated solenoid valves	180
N37...	300	Direct operated solenoid valves	180
N38...	300	Direct operated solenoid valves	180
N776...	N776	Poppet valves and solenoid valves	222
N776/V...	N776	Poppet valves and solenoid valves	224
P3...	300	Direct operated solenoid valves	181
P377.4...	300	Direct operated solenoid valves	182
P395...	300	Direct operated solenoid valves	183
PVA.B...T...	PVA	Poppet valves and solenoid valves	250
PVA.B...Y...	PVA	Poppet valves and solenoid valves	251
PVF...	F300	Poppet valves and solenoid valves	282
RDR...	Mini-RAP	Accessories - Compact fittings for lubrication	372
RDR560	3000	Solenoid valves manifold	537
RGR...	Mini-RAP	Accessories - Compact fittings for lubrication	372
S...	300	Direct operated solenoid valves	204
SPLP...	2500-F	Solenoid valves manifold	464
SPLR...	2500-T	Solenoid valves manifold	496
SPLR...	2200	Solenoid valves manifold	426
T224...11...	T200	Spool valves & solenoid valves	66
T224...8...	T200	Spool valves & solenoid valves	64
T224...9...	T200	Spool valves & solenoid valves	64-65
T224.53...11...	T200	Spool valves & solenoid valves	67
T224.53...9...	T200	Spool valves & solenoid valves	65
T228...0...	T200	Spool valves & solenoid valves	55
T228...1...	T200	Spool valves & solenoid valves	55
T228...11...	T200	Spool valves & solenoid valves	62-63
T228...2...	T200	Spool valves & solenoid valves	55-56
T228...3...	T200	Spool valves & solenoid valves	56
T228...5...	T200	Spool valves & solenoid valves	57
T228...55...	T200	Spool valves & solenoid valves	57
T228...6...	T200	Spool valves & solenoid valves	57-58-59
T228...7...	T200	Spool valves & solenoid valves	59
T228...8...	T200	Spool valves & solenoid valves	60
T228...9...	T200	Spool valves & solenoid valves	60-61
T228.53...11...	T200	Spool valves & solenoid valves	63
T228.53...9...	T200	Spool valves & solenoid valves	61
T424...	T400	Spool valves & solenoid valves	121
T424...0.0...	T400	Spool valves & solenoid valves	119
T424...0.1...	T400	Spool valves & solenoid valves	117
T424...0.12...	T400	Spool valves & solenoid valves	118
T424.00	T400	Spool valves & solenoid valves	121
T424.53...0...	T400	Spool valves & solenoid valves	120

Coding	Series	Family	Page
T488...	T400	Spool valves & solenoid valves	116
T488...0.0...	T400	Spool valves & solenoid valves	114
T488...0.1...	T400	Spool valves & solenoid valves	112
T488...0.12...	T400	Spool valves & solenoid valves	113
T488...11.1	T400	Spool valves & solenoid valves	110
T488...11.11	T400	Spool valves & solenoid valves	110
T488...11.12	T400	Spool valves & solenoid valves	110
T488.00	T400	Spool valves & solenoid valves	116
T488.53...0...	T400	Spool valves & solenoid valves	115
T488.53...11.11	T400	Spool valves & solenoid valves	111
T50...	50-T50	Accessories - Blocking valves	352-353
T514...	T514	"Namur" valves and solenoid valves	286-287-288
T514.92...	T514	"Namur" valves and solenoid valves	289
T771...	T771	Poppet valves and solenoid valves	242-243
T771...BP	T771	Poppet valves and solenoid valves	247
T771/V...	T771	Poppet valves and solenoid valves	245-246
T771/V.32...BP	T771	Poppet valves and solenoid valves	248
T771/VS...	T771	Poppet valves and solenoid valves	246
T771/VS.32...BP	T771	Poppet valves and solenoid valves	248
T771S...	T771	Poppet valves and solenoid valves	243-244
T771S...BP	T771	Poppet valves and solenoid valves	247
T772...	T772-773	Poppet valves and solenoid valves	227-228
T772...BP	T772-773	Poppet valves and solenoid valves	237
T772/V...	T772-773	Poppet valves and solenoid valves	230-231
T772/V...BP	T772-773	Poppet valves and solenoid valves	239
T772/VS...	T772-773	Poppet valves and solenoid valves	231
T772/VS...BP	T772-773	Poppet valves and solenoid valves	240
T772S...	T772-773	Poppet valves and solenoid valves	228-229
T772S...BP	T772-773	Poppet valves and solenoid valves	238
T773...	T772-773	Poppet valves and solenoid valves	232-233
T773...BP	T772-773	Poppet valves and solenoid valves	237
T773/V...	T772-773	Poppet valves and solenoid valves	235-236
T773/V...BP	T772-773	Poppet valves and solenoid valves	239
T773/VS...	T772-773	Poppet valves and solenoid valves	236
T773/VS...BP	T772-773	Poppet valves and solenoid valves	240
T773S...	T772-773	Poppet valves and solenoid valves	233-234
T773S...BP	T772-773	Poppet valves and solenoid valves	238
U3...	300	Direct operated solenoid valves	207
UM2...	300	Direct operated solenoid valves	206
UM2/1...	300	Direct operated solenoid valves	206
UMB...	300	Direct operated solenoid valves	206-207
UMC...	300	Direct operated solenoid valves	207
UN3...	300	Direct operated solenoid valves	206
US...	300	Direct operated solenoid valves	207
XME...	F300	Poppet valves and solenoid valves	281



## Air service units

Coding	Series	Family	Page
10770A...	1700	Air service units	159
10770B...	1700	Air service units	159
1320.50.05/1F	1700 standard	Pressure booster	214
17001A...	1700	Air service units	92-95
17001B...	1700	Air service units	92-95
17003A...	1700	Air service units	132-135
17003B...	1700	Air service units	132-135
17004A...	1700	Air service units	102-105
17004B...	1700	Air service units	102-105
17006A...	1700	Air service units	150-153
17006B...	1700	Air service units	150-153
17007A...	1700	Air service units	154-157
17007B...	1700	Air service units	154-157
17008A.E...	1700	Air service units	96-99
17008B.E...	1700	Air service units	96-99
17022A...	1700	Air service units	106-110
17022B...	1700	Air service units	106-110
17030.A	1700	Air service units	136-137
17030.B	1700	Air service units	136-137
17030.M2	1700	Air service units	138-139
17030.M2/9	1700	Air service units	138-139
17030.PN	1700	Air service units	140-141
17050	1700	Air service units	159
17070A...	P+	Pressure booster	219
17070A...	Airplus	Air service units	32; 38; 52; 80
17070B...	Airplus	Air service units	32; 38; 52; 80
17070MA	1700	Air service units	159
17070MB	1700	Air service units	159
17070MC	1700	Air service units	159
170B2A...	1700	Air service units	127-128
170B2B...	1700	Air service units	127-128
170E0M.C.M...	1700 - Miniaturized	Proportional technology	191
170E0M.C.M...E	1700 - Miniaturized	Proportional technology	198
170E0M.C.M...EFO	1700 - Miniaturized	Proportional technology	199
170E0M.C.M...EFV	1700 - Miniaturized	Proportional technology	200
170E0M.C.M...ETO	1700 - Miniaturized	Proportional technology	201
170E0M.C.M...ETV	1700 - Miniaturized	Proportional technology	202
170E0M.C.M...FO	1700 - Miniaturized	Proportional technology	192
170E0M.C.M...FP	1700 - Miniaturized	Proportional technology	194
170E0M.C.M...FV	1700 - Miniaturized	Proportional technology	193
170E0M.C.M...TO	1700 - Miniaturized	Proportional technology	195
170E0M.C.M...TP	1700 - Miniaturized	Proportional technology	197
170E0M.C.M...TV	1700 - Miniaturized	Proportional technology	196
170E0M.T.M...	1700 - Miniaturized	Proportional technology	191
170E0M.T.M...E	1700 - Miniaturized	Proportional technology	198
170E0M.T.M...EFO	1700 - Miniaturized	Proportional technology	199
170E0M.T.M...EFV	1700 - Miniaturized	Proportional technology	200
170E0M.T.M...ETO	1700 - Miniaturized	Proportional technology	201
170E0M.T.M...ETV	1700 - Miniaturized	Proportional technology	202
170E0M.T.M...FO	1700 - Miniaturized	Proportional technology	192
170E0M.T.M...FP	1700 - Miniaturized	Proportional technology	194
170E0M.T.M...FV	1700 - Miniaturized	Proportional technology	193
170E0M.T.M...TO	1700 - Miniaturized	Proportional technology	195
170E0M.T.M...TP	1700 - Miniaturized	Proportional technology	197
170E0M.T.M...TV	1700 - Miniaturized	Proportional technology	196
170E2M.C.M...	1700 - Miniaturized	Proportional technology	191
170E2M.C.M...E	1700 - Miniaturized	Proportional technology	198

Coding	Series	Family	Page
170E2M.C.M...EFO	1700 - Miniaturized	Proportional technology	199
170E2M.C.M...EFV	1700 - Miniaturized	Proportional technology	200
170E2M.C.M...ETO	1700 - Miniaturized	Proportional technology	201
170E2M.C.M...ETV	1700 - Miniaturized	Proportional technology	202
170E2M.C.M...FO	1700 - Miniaturized	Proportional technology	192
170E2M.C.M...FP	1700 - Miniaturized	Proportional technology	194
170E2M.C.M...FV	1700 - Miniaturized	Proportional technology	193
170E2M.C.M...TO	1700 - Miniaturized	Proportional technology	195
170E2M.C.M...TP	1700 - Miniaturized	Proportional technology	197
170E2M.C.M...TV	1700 - Miniaturized	Proportional technology	196
170E2M.T.M...	1700 - Miniaturized	Proportional technology	191
170E2M.T.M...E	1700 - Miniaturized	Proportional technology	198
170E2M.T.M...EFO	1700 - Miniaturized	Proportional technology	199
170E2M.T.M...EFV	1700 - Miniaturized	Proportional technology	200
170E2M.T.M...ETO	1700 - Miniaturized	Proportional technology	201
170E2M.T.M...ETV	1700 - Miniaturized	Proportional technology	202
170E2M.T.M...FO	1700 - Miniaturized	Proportional technology	192
170E2M.T.M...FP	1700 - Miniaturized	Proportional technology	194
170E2M.T.M...FV	1700 - Miniaturized	Proportional technology	193
170E2M.T.M...TO	1700 - Miniaturized	Proportional technology	195
170E2M.T.M...TP	1700 - Miniaturized	Proportional technology	197
170E2M.T.M...TV	1700 - Miniaturized	Proportional technology	196
170E2N.C.D...	1700 standard	Proportional technology	187
170E2N.C.F...	1700 standard	Proportional technology	189
170E2N.C.M...	1700 standard	Proportional technology	188
170E2N.I.B...	1700 standard	Proportional technology	189
170E2N.M.C...	1700 standard	Proportional technology	188
170E2N.S.C...	1700 standard	Proportional technology	187
170E2N.T.D...	1700 standard	Proportional technology	187
170E2N.T.G...	1700 standard	Proportional technology	189
170E2N.T.H...	1700 standard	Proportional technology	189
170E2N.T.M...	1700 standard	Proportional technology	188
170M...EFO	1700 - Miniaturized	Proportional technology	205
170M...EFV	1700 - Miniaturized	Proportional technology	205
170M...FO	1700 - Miniaturized	Proportional technology	204
170M...FV	1700 - Miniaturized	Proportional technology	204
170M1.EFO	1700 - Miniaturized	Proportional technology	199
170M1.EFV	1700 - Miniaturized	Proportional technology	200
170M1.ETO	1700 - Miniaturized	Proportional technology	201
170M1.ETV	1700 - Miniaturized	Proportional technology	202
170M1.FO	1700 - Miniaturized	Proportional technology	192
170M1.FP	1700 - Miniaturized	Proportional technology	194
170M1.FV	1700 - Miniaturized	Proportional technology	193
170M1.TO	1700 - Miniaturized	Proportional technology	195
170M1.TP	1700 - Miniaturized	Proportional technology	197
170M1.TV	1700 - Miniaturized	Proportional technology	196
170M2A...	1700	Air service units	127-128
170M2B...	1700	Air service units	127-128
170M5	1700	Air service units	158
170M5	1700 standard	Proportional technology	187-188-189
170M6	1700	Air service units	160
17100.125N	1700 standard	Pressure booster	213
17100.125NR	1700 standard	Pressure booster	213
17101A...	1700	Air service units	92-95
17101B...	1700	Air service units	92-95
17103A...	1700	Air service units	132-135
17103B...	1700	Air service units	132-135
17104A...	1700	Air service units	102-105
17104B...	1700	Air service units	102-105



Coding	Series	Family	Page
17106A...	1700	Air service units	150-153
17106B...	1700	Air service units	150-153
17107A...	1700	Air service units	154-157
17107B...	1700	Air service units	154-157
17108A.E...	1700	Air service units	96-99
17108B.E...	1700	Air service units	96-99
17109A...	1700	Air service units	123-124
17109B...	1700	Air service units	123-124
17110.M2	1700	Air service units	142-143
17120	1700	Air service units	142-143
17122A...	1700	Air service units	106-110
17122B...	1700	Air service units	106-110
17129A...	1700	Air service units	125-126
17129B...	1700	Air service units	125-126
17130.A	1700	Air service units	136-137
17130.B	1700	Air service units	136-137
17130.M2	1700	Air service units	138-139
17130.M2/9	1700	Air service units	138-139
17130.MPN	1700	Air service units	140-141
17140	1700	Air service units	140-141
17140H	1700	Air service units	146-147
1714A	1700	Air service units	148-149
1714B	1700	Air service units	148-149
1714C	1700	Air service units	148-149
17150	1700	Air service units	158
17150	Airplus	Air service units	32; 38; 52
17160	1700	Air service units	160
171E2N.C.D...	1700 standard	Proportional technology	187
171E2N.C.F...	1700 standard	Proportional technology	189
171E2N.C.M...	1700 standard	Proportional technology	188
171E2N.I.B...	1700 standard	Proportional technology	189
171E2N.M.C...	1700 standard	Proportional technology	188
171E2N.S.C...	1700 standard	Proportional technology	187
171E2N.T.D...	1700 standard	Proportional technology	187
171E2N.T.G...	1700 standard	Proportional technology	189
171E2N.T.H...	1700 standard	Proportional technology	189
171E2N.T.M...	1700 standard	Proportional technology	188
171S2B...	1700	Air service units	114-116
17201A...	1700	Air service units	92-95
17201B...	1700	Air service units	92-95
17202A.P...	1700	Air service units	117-120
17202B.P...	1700	Air service units	117-120
17203A...	1700	Air service units	132-135
17203B...	1700	Air service units	132-135
17204A...	1700	Air service units	102-105
17204B...	1700	Air service units	102-105
17206A...	1700	Air service units	150-153
17206B...	1700	Air service units	150-153
17207A...	1700	Air service units	154-157
17207B...	1700	Air service units	154-157
17208A.E...	1700	Air service units	96-99
17208B.E...	1700	Air service units	96-99
17210.M2	1700	Air service units	142-143
17220	1700	Air service units	142-143
17222A...	1700	Air service units	106-110
17222B...	1700	Air service units	106-110
17230.A	1700	Air service units	136-137
17230.B	1700	Air service units	136-137
17230.M2	1700	Air service units	138-139

Coding	Series	Family	Page
17230.M2/9	1700	Air service units	138-139
17230.PN	1700	Air service units	140-141
17240	1700	Air service units	144-145
17240H	1700	Air service units	146-147
1724A	1700	Air service units	148-149
1724C	1700	Air service units	148-149
17250	1700	Air service units	158
17260	1700	Air service units	160
17301A...	1700	Air service units	92-95
17301B...	1700	Air service units	92-95
17301E...	1700	Air service units	92-95
17302A.P...	1700	Air service units	117-120
17302B.C	1700 standard	Pressure booster	214
17302B.P...	1700	Air service units	117-120
17303A...	1700	Air service units	132-135
17303B...	1700	Air service units	132-135
17303E...	1700	Air service units	132-135
17304A...	1700	Air service units	102-105
17304B...	1700	Air service units	102-105
17304E...	1700	Air service units	102-105
17306A...	1700	Air service units	150-153
17306B...	1700	Air service units	150-153
17306E...	1700	Air service units	150-153
17307A...	1700	Air service units	154-157
17307B...	1700	Air service units	154-157
17307E...	1700	Air service units	154-157
17308A.E...	1700	Air service units	96-99
17308B.E...	1700	Air service units	96-99
17308E.E...	1700	Air service units	96-99
17310.M2	1700	Air service units	142-143
17320	1700	Air service units	142-143
17322A...	1700	Air service units	106-110
17322B...	1700	Air service units	106-110
17330.A	1700	Air service units	136-137
17330.B	1700	Air service units	136-137
17330.M2	1700	Air service units	138-139
17330.M2/9	1700	Air service units	138-139
17330.PN	1700	Air service units	140-141
17340	1700	Air service units	144-145
17340H	1700	Air service units	146-147
1734A	1700	Air service units	148-149
1734C	1700	Air service units	148-149
17350	1700	Air service units	158
17360	1700	Air service units	160
17381E	1700	Air service units	160
17382E	1700	Air service units	160
173E2N.C.D...	1700 standard	Proportional technology	187
173E2N.C.F...	1700 standard	Proportional technology	189
173E2N.C.M...	1700 standard	Proportional technology	188
173E2N.I.B...	1700 standard	Proportional technology	189
173E2N.M.C...	1700 standard	Proportional technology	188
173E2N.S.C...	1700 standard	Proportional technology	187
173E2N.T.D...	1700 standard	Proportional technology	187
173E2N.T.G...	1700 standard	Proportional technology	189
173E2N.T.H...	1700 standard	Proportional technology	189
173E2N.T.M...	1700 standard	Proportional technology	188
173P2B.0010	1700	Air service units	121-122
173S2B...	1700	Air service units	114-116
1740.02	1700 standard	Pressure booster	214



Coding	Series	Family	Page
1740.50.NR	1700 standard	Pressure booster	211
1740.50N	1700 standard	Pressure booster	211
1740.BR	1700 standard	Pressure booster	214
17401B...	1700	Air service units	92-95
17402NB.P...	1700	Air service units	117-120
17403B...	1700	Air service units	132-135
17408B.E...	1700	Air service units	96-99
1740EB.A.S	1700	Air service units	100-101
1740EB.B.S	1700	Air service units	100-101
1740EB.C.S	1700	Air service units	100-101
17410.M2	1700	Air service units	142-143
17420	1700	Air service units	142-143
17430.A	1700	Air service units	136-137
17430.B	1700	Air service units	136-137
17440	1700	Air service units	144-145
1744A	1700	Air service units	148-149
1744C	1700	Air service units	148-149
17460	1700	Air service units	160
1763.02	1700 standard	Pressure booster	214
1763.80.NR	1700 standard	Pressure booster	212
1763.80N	1700 standard	Pressure booster	212
1763.BR	1700 standard	Pressure booster	214
17BB2A...	1700	Air service units	129-131
17BB2B...	1700	Air service units	129-131
17BM2A...	1700	Air service units	129-131
17BM2B...	1700	Air service units	129-131
5312A.F04.00	1700 standard	Proportional technology	189
5312A.F05.00	1700 standard	Proportional technology	189
800.00	1700 - Miniaturized	Proportional technology	205
DS.10.PB...	DS	Measuring devices - Pressure switches	206
DS.45.P...	DS	Measuring devices - Pressure switches	207
DS.60.PI.F1.F.0	DS	Measuring devices - Pressure gauges	208
DS.61.PI.F1...	DS	Measuring devices - Pressure gauges	209
G1700...	1700 - Miniaturized	Proportional technology	203
G1702...	1700 - Miniaturized	Proportional technology	203
GL171AP...	Airplus	Air service units	82-86
GL171BP...	Airplus	Air service units	82-86
GL171CP...	Airplus	Air service units	82-86
GL172AP...	Airplus	Air service units	82-86
GL172BP...	Airplus	Air service units	82-86
GL172CP...	Airplus	Air service units	82-86
GL173AP...	Airplus	Air service units	82-86
GL173BP...	Airplus	Air service units	82-86
GL173CP...	Airplus	Air service units	82-86
GL174BP...	Airplus	Air service units	82-86
GN171A...	Airplus	Air service units	46-48
GN171AP...	Airplus	Air service units	82-86
GN171B...	Airplus	Air service units	46-48
GN171BP...	Airplus	Air service units	82-86
GN171C...	Airplus	Air service units	48-50
GN171CP...	Airplus	Air service units	82-86
GN172AP...	Airplus	Air service units	82-86
GN172BP...	Airplus	Air service units	82-86
GN172CP...	Airplus	Air service units	82-86
GN173AP...	Airplus	Air service units	82-86
GN173BP...	Airplus	Air service units	82-86
GN173CP...	Airplus	Air service units	82-86

Coding	Series	Family	Page
GN174BP...	Airplus	Air service units	82-86
GP171AP...	Airplus	Air service units	82-86
GP171BP...	Airplus	Air service units	82-86
GP171CP...	Airplus	Air service units	82-86
GP172AP...	Airplus	Air service units	82-86
GP172BP...	Airplus	Air service units	82-86
GP172CP...	Airplus	Air service units	82-86
GP173AP...	Airplus	Air service units	82-86
GP173BP...	Airplus	Air service units	82-86
GP173CP...	Airplus	Air service units	82-86
GP174BP...	Airplus	Air service units	82-86
GT171A...	Airplus	Air service units	48-50
GT171AP...	Airplus	Air service units	82-86
GT171B...	Airplus	Air service units	48-50
GT171BP...	Airplus	Air service units	82-86
GT171C...	Airplus	Air service units	48-50
GT171CP...	Airplus	Air service units	82-86
GT172AP...	Airplus	Air service units	82-86
GT172BP...	Airplus	Air service units	82-86
GT172CP...	Airplus	Air service units	82-86
GT173AP...	Airplus	Air service units	82-86
GT173BP...	Airplus	Air service units	82-86
GT173CP...	Airplus	Air service units	82-86
GT174BP...	Airplus	Air service units	82-86
L171ADA...	Airplus	Air service units	10-14
L171AE...	Airplus	Air service units	25-30
L171AF...	Airplus	Air service units	5-9
L171AR...	Airplus	Air service units	31-37
L171AV...	Airplus	Air service units	58-61
L171BDA...	Airplus	Air service units	10-14
L171BE...	Airplus	Air service units	25-30
L171BF...	Airplus	Air service units	5-9
L171BR...	Airplus	Air service units	33-37
L171BV...	Airplus	Air service units	58-61
L171CDA...	Airplus	Air service units	10-14
L171CE...	Airplus	Air service units	25-30
L171CF...	Airplus	Air service units	5-9
L171CR...	Airplus	Air service units	33-37
L171CV...	Airplus	Air service units	58-61
L172ADA...	Airplus	Air service units	10-14
L172AE...	Airplus	Air service units	25-30
L172AF...	Airplus	Air service units	5-9
L172AR...	Airplus	Air service units	33-37
L172AV...	Airplus	Air service units	58-61
L172BDA...	Airplus	Air service units	10-14
L172BE...	Airplus	Air service units	25-30
L172BF...	Airplus	Air service units	5-9
L172BR...	Airplus	Air service units	33-37
L172BV...	Airplus	Air service units	58-61
L172CDA...	Airplus	Air service units	10-14
L172CE...	Airplus	Air service units	25-30
L172CF...	Airplus	Air service units	5-9
L172CR...	Airplus	Air service units	33-37
L172CV...	Airplus	Air service units	58-61
L173ADA...	Airplus	Air service units	10-14
L173ADD...	Airplus	Air service units	20-24
L173AE...	Airplus	Air service units	25-30
L173AF...	Airplus	Air service units	5-9
L173AR...	Airplus	Air service units	33-37



Coding	Series	Family	Page
L173AV...	Airplus	Air service units	58-61
L173BDA...	Airplus	Air service units	10-14
L173BDD...	Airplus	Air service units	20-24
L173BE...	Airplus	Air service units	25-30
L173BF...	Airplus	Air service units	5-9
L173BR...	Airplus	Air service units	33-37
L173BV...	Airplus	Air service units	58-61
L173CDA...	Airplus	Air service units	10-14
L173CDD...	Airplus	Air service units	20-24
L173CE...	Airplus	Air service units	25-30
L173CF...	Airplus	Air service units	5-9
L173CR...	Airplus	Air service units	33-37
L173CV...	Airplus	Air service units	58-61
L174BDA...	Airplus	Air service units	10-14
L174BDD...	Airplus	Air service units	20-24
L174BE...	Airplus	Air service units	25-30
L174BF...	Airplus	Air service units	5-9
L174BR...	Airplus	Air service units	33-37
L174BV...	Airplus	Air service units	58-61
L174CE...	Airplus	Air service units	25-30
L174CF...	Airplus	Air service units	5-9
L174CR...	Airplus	Air service units	33-37
MDPT40.2R...	P+	Pressure booster	218
N171AAP...	Airplus	Air service units	62-64
N171AB...	Airplus	Air service units	44-47
N171ADA...	Airplus	Air service units	10-14
N171AE...	Airplus	Air service units	25-30
N171AF...	Airplus	Air service units	5-9
N171AL...	Airplus	Air service units	53-57
N171AM...	Airplus	Air service units	44-47
N171AP...	Airplus	Air service units	70-74
N171APA...	Airplus	Air service units	65-66
N171APP...	Airplus	Air service units	67-69
N171AR...	Airplus	Air service units	33-37
N171AV...	Airplus	Air service units	58-61
N171BAP...	Airplus	Air service units	62-64
N171BB...	Airplus	Air service units	44-47
N171BDA...	Airplus	Air service units	10-14
N171BE...	Airplus	Air service units	25-30
N171BF...	Airplus	Air service units	5-9
N171BL...	Airplus	Air service units	53-57
N171BM...	Airplus	Air service units	44-47
N171BP...	Airplus	Air service units	70-74
N171BPA...	Airplus	Air service units	65-66
N171BPP...	Airplus	Air service units	67-69
N171BR...	Airplus	Air service units	33-37
N171BV...	Airplus	Air service units	58-61
N171CAP...	Airplus	Air service units	62-64
N171CB...	Airplus	Air service units	44-47
N171CDA...	Airplus	Air service units	10-14
N171CE...	Airplus	Air service units	25-30
N171CF...	Airplus	Air service units	5-9
N171CL...	Airplus	Air service units	53-57
N171CM...	Airplus	Air service units	44-47
N171CP...	Airplus	Air service units	70-74
N171CPA...	Airplus	Air service units	65-66
N171CPP...	Airplus	Air service units	67-69
N171CR...	Airplus	Air service units	33-37
N171CV...	Airplus	Air service units	58-61

Coding	Series	Family	Page
N171X	Airplus	Air service units	87
N171Y	Airplus	Air service units	87
N171YP	Airplus	Air service units	51
N172AAP...	Airplus	Air service units	62-64
N172ADA...	Airplus	Air service units	10-14
N172AE...	Airplus	Air service units	25-30
N172AF...	Airplus	Air service units	5-9
N172AL...	Airplus	Air service units	53-57
N172AP...	Airplus	Air service units	70-74
N172APA...	Airplus	Air service units	65-66
N172APP...	Airplus	Air service units	67-69
N172AR...	Airplus	Air service units	33-37
N172AV...	Airplus	Air service units	58-61
N172BAP...	Airplus	Air service units	62-64
N172BDA...	Airplus	Air service units	10-14
N172BE...	Airplus	Air service units	25-30
N172BF...	Airplus	Air service units	5-9
N172BL...	Airplus	Air service units	53-57
N172BP...	Airplus	Air service units	70-74
N172BPA...	Airplus	Air service units	65-66
N172BPP...	Airplus	Air service units	67-69
N172BR...	Airplus	Air service units	33-37
N172BV...	Airplus	Air service units	58-61
N172CAP...	Airplus	Air service units	62-64
N172CDA...	Airplus	Air service units	10-14
N172CE...	Airplus	Air service units	25-30
N172CF...	Airplus	Air service units	5-9
N172CL...	Airplus	Air service units	53-57
N172CP...	Airplus	Air service units	70-74
N172CPA...	Airplus	Air service units	65-66
N172CPP...	Airplus	Air service units	67-68
N172CR...	Airplus	Air service units	33-3
N172CV...	Airplus	Air service units	58-60
N172X	Airplus	Air service units	87
N172Y	Airplus	Air service units	87
N173AAP...	Airplus	Air service units	62-64
N173ADA...	Airplus	Air service units	10-14
N173ADB...	Airplus	Air service units	15-19
N173ADD...	Airplus	Air service units	20-24
N173AE...	Airplus	Air service units	25-30
N173AF...	Airplus	Air service units	5-9
N173AL...	Airplus	Air service units	53-57
N173AP...	Airplus	Air service units	70-74
N173APA...	Airplus	Air service units	65-66
N173APP...	Airplus	Air service units	67-69
N173AR...	Airplus	Air service units	33-37
N173AV...	Airplus	Air service units	58-61
N173BAP...	Airplus	Air service units	62-64
N173BDA...	Airplus	Air service units	10-14
N173BDB...	Airplus	Air service units	15-19
N173BDC...	Airplus	Air service units	15-19
N173BDD...	Airplus	Air service units	20-24
N173BE...	Airplus	Air service units	25-30
N173BF...	Airplus	Air service units	5-9
N173BL...	Airplus	Air service units	53-57
N173BP...	Airplus	Air service units	70-74
N173BPA...	Airplus	Air service units	65-66
N173BPP...	Airplus	Air service units	67-69
N173BR...	Airplus	Air service units	33-37



Coding	Series	Family	Page
N173BV...	Airplus	Air service units	58-61
N173BV2S...	Airplus	Air service units	75-81
N173BVS...	Airplus	Air service units	75-81
N173CAP...	Airplus	Air service units	62-64
N173CDA...	Airplus	Air service units	10-14
N173CDBV...	Airplus	Air service units	15-19
N173CDD...	Airplus	Air service units	20-24
N173CE...	Airplus	Air service units	25-30
N173CF...	Airplus	Air service units	5-9
N173CL...	Airplus	Air service units	53-57
N173CP...	Airplus	Air service units	60-74
N173CPA...	Airplus	Air service units	65-66
N173CPP...	Airplus	Air service units	67-69
N173CR...	Airplus	Air service units	33-37
N173CV...	Airplus	Air service units	58-61
N173X	Airplus	Air service units	87
N173Y	Airplus	Air service units	87
N174BAP...	Airplus	Air service units	62-64
N174BDA...	Airplus	Air service units	10-14
N174BDV...	Airplus	Air service units	15-19
N174BDD...	Airplus	Air service units	20-24
N174BE...	Airplus	Air service units	25-30
N174BF...	Airplus	Air service units	5-9
N174BL...	Airplus	Air service units	53-57
N174BP...	Airplus	Air service units	70-74
N174BPA...	Airplus	Air service units	65-66
N174BPP...	Airplus	Air service units	67-69
N174BR...	Airplus	Air service units	33-37
N174BV...	Airplus	Air service units	58-61
N174CE...	Airplus	Air service units	25-30
N174CF...	Airplus	Air service units	5-9
N174CR...	Airplus	Air service units	33-37
N174X	Airplus	Air service units	87
N174Y	Airplus	Air service units	87
P171AAP...	Airplus	Air service units	62-64
P171ADA...	Airplus	Air service units	10-14
P171AE...	Airplus	Air service units	25-30
P171AF...	Airplus	Air service units	5-9
P171AL...	Airplus	Air service units	53-57
P171AP...	Airplus	Air service units	70-74
P171APA...	Airplus	Air service units	65-66
P171APP...	Airplus	Air service units	67-69
P171AR...	Airplus	Air service units	33-37
P171AV...	Airplus	Air service units	58-61
P171BAP...	Airplus	Air service units	62-64
P171BDA...	Airplus	Air service units	10-14
P171BE...	Airplus	Air service units	25-30
P171BF...	Airplus	Air service units	5-9
P171BL...	Airplus	Air service units	53-57
P171BP...	Airplus	Air service units	70-74
P171BPA...	Airplus	Air service units	65-66
P171BPP...	Airplus	Air service units	67-69
P171BR...	Airplus	Air service units	33-37
P171BV...	Airplus	Air service units	58-61
P171CAP...	Airplus	Air service units	62-64
P171CDA...	Airplus	Air service units	10-14
P171CE...	Airplus	Air service units	25-30
P171CF...	Airplus	Air service units	5-9
P171CL...	Airplus	Air service units	53-57

Coding	Series	Family	Page
P171CP...	Airplus	Air service units	70-74
P171CPA...	Airplus	Air service units	65-66
P171CPP...	Airplus	Air service units	67-69
P171CR...	Airplus	Air service units	33-37
P171CV...	Airplus	Air service units	58-61
P172AAP...	Airplus	Air service units	62-64
P172ADA...	Airplus	Air service units	10-14
P172AE...	Airplus	Air service units	25-30
P172AF...	Airplus	Air service units	5-9
P172AL...	Airplus	Air service units	53-57
P172AP...	Airplus	Air service units	70-74
P172APA...	Airplus	Air service units	65-66
P172APP...	Airplus	Air service units	67-69
P172AR...	Airplus	Air service units	33-37
P172AV...	Airplus	Air service units	58-61
P172BAP...	Airplus	Air service units	62-64
P172BDA...	Airplus	Air service units	10-14
P172BE...	Airplus	Air service units	25-30
P172BF...	Airplus	Air service units	5-9
P172BL...	Airplus	Air service units	53-57
P172BP...	Airplus	Air service units	70-74
P172BPA...	Airplus	Air service units	65-66
P172BPP...	Airplus	Air service units	67-69
P172BR...	Airplus	Air service units	33-37
P172BV...	Airplus	Air service units	58-61
P172CAP...	Airplus	Air service units	62-64
P172CDA...	Airplus	Air service units	10-14
P172CE...	Airplus	Air service units	25-30
P172CF...	Airplus	Air service units	5-9
P172CL...	Airplus	Air service units	53-57
P172CP...	Airplus	Air service units	70-74
P172CPA...	Airplus	Air service units	65-66
P172CPP...	Airplus	Air service units	67-69
P172CR...	Airplus	Air service units	33-37
P172CV...	Airplus	Air service units	58-61
P173AAP...	Airplus	Air service units	62-64
P173ADA...	Airplus	Air service units	10-14
P173ADB...	Airplus	Air service units	15-19
P173ADD...	Airplus	Air service units	20-24
P173AE...	Airplus	Air service units	25-30
P173AF...	Airplus	Air service units	5-9
P173AL...	Airplus	Air service units	53-57
P173AP...	Airplus	Air service units	70-74
P173APA...	Airplus	Air service units	65-66
P173APP...	Airplus	Air service units	67-69
P173AR...	Airplus	Air service units	33-37
P173AV...	Airplus	Air service units	58-61
P173BAP...	Airplus	Air service units	62-64
P173BDA...	Airplus	Air service units	10-14
P173BDB...	Airplus	Air service units	15-19
P173BDC...	Airplus	Air service units	15-19
P173BDD...	Airplus	Air service units	20-24
P173BE...	Airplus	Air service units	25-30
P173BF...	Airplus	Air service units	5-9
P173BL...	Airplus	Air service units	53-57
P173BP...	Airplus	Air service units	70-74
P173BPA...	Airplus	Air service units	65-66
P173BPP...	Airplus	Air service units	67-69
P173BR...	Airplus	Air service units	33-37





Coding	Series	Family	Page
P173BV...	Airplus	Air service units	58-61
P173CAP...	Airplus	Air service units	62-64
P173CDA...	Airplus	Air service units	10-14
P173CDBV...	Airplus	Air service units	15-19
P173CDD...	Airplus	Air service units	20-24
P173CE...	Airplus	Air service units	25-30
P173CF...	Airplus	Air service units	5-9
P173CL...	Airplus	Air service units	53-57
P173CP...	Airplus	Air service units	70-74
P173CPA...	Airplus	Air service units	65-66
P173CPP...	Airplus	Air service units	67-69
P173CR...	Airplus	Air service units	33-37
P173CV...	Airplus	Air service units	58-61
P174BAP...	Airplus	Air service units	62-64
P174BDA...	Airplus	Air service units	10-14
P174BDAV...	Airplus	Air service units	15-19
P174BDD...	Airplus	Air service units	20-24
P174BE...	Airplus	Air service units	25-30
P174BF...	Airplus	Air service units	5-9
P174BL...	Airplus	Air service units	53-57
P174BP...	Airplus	Air service units	70-74
P174BPA...	Airplus	Air service units	65-66
P174BPP...	Airplus	Air service units	67-69
P174BR...	Airplus	Air service units	33-37
P174BR...P	Airplus	Air service units	39-42
P174BV...	Airplus	Air service units	58-61
P174CE...	Airplus	Air service units	25-30
P174CF...	Airplus	Air service units	5-9
P174CR...	Airplus	Air service units	33-37
P174CR...P	Airplus	Air service units	39-42
SF172AE...	1700 Steel line	Air service units	164
SF172AF...	1700 Steel line	Air service units	162
SF172AR...	1700 Steel line	Air service units	163
SF172BE...	1700 Steel line	Air service units	164
SF172BF...	1700 Steel line	Air service units	162
SF172BR...	1700 Steel line	Air service units	163
SF172CE...	1700 Steel line	Air service units	164
SF172CF...	1700 Steel line	Air service units	162
SF172CR...	1700 Steel line	Air service units	163
SF173AE...	1700 Steel line	Air service units	168
SF173AF...	1700 Steel line	Air service units	166
SF173AR...	1700 Steel line	Air service units	167
SF173BE...	1700 Steel line	Air service units	168
SF173BF...	1700 Steel line	Air service units	166
SF173BR...	1700 Steel line	Air service units	167
SF173DE...	1700 Steel line	Air service units	168
SF173DF...	1700 Steel line	Air service units	166
SF173DR...	1700 Steel line	Air service units	167
SF174AE...	1700 Steel line	Air service units	172
SF174AF...	1700 Steel line	Air service units	170
SF174AR...	1700 Steel line	Air service units	171
SF174BE...	1700 Steel line	Air service units	172
SF174BF...	1700 Steel line	Air service units	170
SF174BR...	1700 Steel line	Air service units	171
SF174DE...	1700 Steel line	Air service units	172
SF174DF...	1700 Steel line	Air service units	170
SF174DR...	1700 Steel line	Air service units	171
SM172AE...	1700 Steel line	Air service units	164
SM172BE...	1700 Steel line	Air service units	164

Coding	Series	Family	Page
SM172CE...	1700 Steel line	Air service units	164
SM173AE...	1700 Steel line	Air service units	168
SM173BE...	1700 Steel line	Air service units	168
SM173DE...	1700 Steel line	Air service units	168
SM174AE...	1700 Steel line	Air service units	172
SM174BE...	1700 Steel line	Air service units	172
SM174DE...	1700 Steel line	Air service units	172
SS17070AA	1700 Steel line	Air service units	165
SS17070AA	1700 Steel line	Air service units	169
SS17070AA	1700 Steel line	Air service units	173
SS17070AB	1700 Steel line	Air service units	165
SS17070AB	1700 Steel line	Air service units	169
SS17070AB	1700 Steel line	Air service units	173
SS17250	1700 Steel line	Air service units	165
SS172AE...	1700 Steel line	Air service units	164
SS172AF...	1700 Steel line	Air service units	162
SS172AR...	1700 Steel line	Air service units	163
SS172BE...	1700 Steel line	Air service units	164
SS172BF...	1700 Steel line	Air service units	162
SS172BR...	1700 Steel line	Air service units	163
SS172CE...	1700 Steel line	Air service units	164
SS172CF...	1700 Steel line	Air service units	162
SS172CR...	1700 Steel line	Air service units	163
SS17350	1700 Steel line	Air service units	169
SS173AE...	1700 Steel line	Air service units	168
SS173AF...	1700 Steel line	Air service units	166
SS173AR...	1700 Steel line	Air service units	167
SS173BE...	1700 Steel line	Air service units	168
SS173BF...	1700 Steel line	Air service units	166
SS173BR...	1700 Steel line	Air service units	167
SS173DE...	1700 Steel line	Air service units	168
SS173DF...	1700 Steel line	Air service units	166
SS173DR...	1700 Steel line	Air service units	167
SS17450	1700 Steel line	Air service units	173
SS174AE...	1700 Steel line	Air service units	172
SS174AF...	1700 Steel line	Air service units	170
SS174AR...	1700 Steel line	Air service units	171
SS174BE...	1700 Steel line	Air service units	172
SS174BF...	1700 Steel line	Air service units	170
SS174BR...	1700 Steel line	Air service units	171
SS174DE...	1700 Steel line	Air service units	172
SS174DF...	1700 Steel line	Air service units	170
SS174DR...	1700 Steel line	Air service units	171
T171AAP...	Airplus	Air service units	62-64
T171AB...	Airplus	Air service units	44-47
T171ADA...	Airplus	Air service units	10-14
T171AE...	Airplus	Air service units	25-30
T171AF...	Airplus	Air service units	5-9
T171AL...	Airplus	Air service units	53-57
T171AM...	Airplus	Air service units	44-47
T171AP...	Airplus	Air service units	70-74
T171APA...	Airplus	Air service units	65-66
T171APP...	Airplus	Air service units	67-69
T171AR...	Airplus	Air service units	33-37
T171AV...	Airplus	Air service units	58-61
T171BAP...	Airplus	Air service units	62-64
T171BB...	Airplus	Air service units	44-47
T171BDA...	Airplus	Air service units	10-14
T171BE...	Airplus	Air service units	25-30



Coding	Series	Family	Page
T171BF...	Airplus	Air service units	5-9
T171BL...	Airplus	Air service units	53-57
T171BM...	Airplus	Air service units	44-47
T171BP...	Airplus	Air service units	70-74
T171BPA...	Airplus	Air service units	65-66
T171BPP...	Airplus	Air service units	67-69
T171BR...	Airplus	Air service units	33-37
T171BV...	Airplus	Air service units	58-61
T171CAP...	Airplus	Air service units	62-64
T171CB...	Airplus	Air service units	44-47
T171CDA...	Airplus	Air service units	10-14
T171CE...	Airplus	Air service units	25-30
T171CF...	Airplus	Air service units	5-9
T171CL...	Airplus	Air service units	53-57
T171CM...	Airplus	Air service units	44-47
T171CP...	Airplus	Air service units	70-74
T171CPA...	Airplus	Air service units	65-66
T171CPP...	Airplus	Air service units	67-69
T171CR...	Airplus	Air service units	33-37
T171CV...	Airplus	Air service units	58-61
T171X	Airplus	Air service units	51
T171X	Airplus	Air service units	87
T171Y	Airplus	Air service units	51
T171Y	Airplus	Air service units	87
T17250	1700	Air service units	158
T17250	Airplus	Air service units	32; 38; 52
T172AAP...	Airplus	Air service units	62-64
T172ADA...	Airplus	Air service units	10-14
T172AE...	Airplus	Air service units	25-30
T172AF...	Airplus	Air service units	5-9
T172AL...	Airplus	Air service units	53-57
T172AP...	Airplus	Air service units	70-74
T172APA...	Airplus	Air service units	65-66
T172APP...	Airplus	Air service units	67-69
T172AR...	Airplus	Air service units	33-37
T172AV...	Airplus	Air service units	58-61
T172BAP...	Airplus	Air service units	62-64
T172BDA...	Airplus	Air service units	10-14
T172BE...	Airplus	Air service units	25-30
T172BF...	Airplus	Air service units	5-9
T172BL...	Airplus	Air service units	53-57
T172BP...	Airplus	Air service units	70-74
T172BPA...	Airplus	Air service units	65-66
T172BPP...	Airplus	Air service units	67-69
T172BR...	Airplus	Air service units	33-37
T172BV...	Airplus	Air service units	58-61
T172CAP...	Airplus	Air service units	62-64
T172CDA...	Airplus	Air service units	10-14
T172CE...	Airplus	Air service units	25-30
T172CF...	Airplus	Air service units	5-9
T172CL...	Airplus	Air service units	53-57
T172CP...	Airplus	Air service units	70-74
T172CPA...	Airplus	Air service units	65-66
T172CPP...	Airplus	Air service units	67-69
T172CR...	Airplus	Air service units	33-37
T172CV...	Airplus	Air service units	58-61
T172X	Airplus	Air service units	87
T172Y	Airplus	Air service units	87
T173AAP...	Airplus	Air service units	62-64

Coding	Series	Family	Page
T173ADA...	Airplus	Air service units	10-14
T173ADB...	Airplus	Air service units	15-19
T173ADD...	Airplus	Air service units	20-24
T173AE...	Airplus	Air service units	25-30
T173AF...	Airplus	Air service units	5-9
T173AL...	Airplus	Air service units	53-57
T173AP...	Airplus	Air service units	70-74
T173APA...	Airplus	Air service units	65-66
T173APP...	Airplus	Air service units	67-69
T173AR...	Airplus	Air service units	33-37
T173AV...	Airplus	Air service units	58-61
T173BAP...	Airplus	Air service units	62-64
T173BDA...	Airplus	Air service units	10-14
T173BDB...	Airplus	Air service units	15-19
T173BDC...	Airplus	Air service units	15-19
T173BDD...	Airplus	Air service units	20-24
T173BE...	Airplus	Air service units	25-30
T173BF...	Airplus	Air service units	5-9
T173BL...	Airplus	Air service units	53-57
T173BP...	Airplus	Air service units	70-74
T173BPA...	Airplus	Air service units	65-66
T173BPP...	Airplus	Air service units	67-69
T173BR...	Airplus	Air service units	33-37
T173BV...	Airplus	Air service units	58-61
T173CAP...	Airplus	Air service units	62-64
T173CDA...	Airplus	Air service units	10-14
T173CDB...	Airplus	Air service units	15-19
T173CDD...	Airplus	Air service units	20-24
T173CE...	Airplus	Air service units	25-30
T173CF...	Airplus	Air service units	5-9
T173CL...	Airplus	Air service units	53-57
T173CP...	Airplus	Air service units	60-74
T173CPA...	Airplus	Air service units	65-66
T173CPP...	Airplus	Air service units	67-69
T173CR...	Airplus	Air service units	33-37
T173CV...	Airplus	Air service units	58-61
T173X	Airplus	Air service units	87
T173Y	Airplus	Air service units	87
T1740.01	P+	Pressure booster	219
T174BAP...	Airplus	Air service units	62-64
T174BDA...	Airplus	Air service units	10-14
T174BAV...	Airplus	Air service units	15-19
T174BDD...	Airplus	Air service units	20-24
T174BE...	Airplus	Air service units	25-30
T174BF...	Airplus	Air service units	5-9
T174BL...	Airplus	Air service units	53-57
T174BP...	Airplus	Air service units	70-74
T174BPA...	Airplus	Air service units	65-66
T174BPP...	Airplus	Air service units	67-69
T174BR...	Airplus	Air service units	33-37
T174BV...	Airplus	Air service units	58-61
T174CE...	Airplus	Air service units	25-30
T174CF...	Airplus	Air service units	5-9
T174CR...	Airplus	Air service units	33-37
T174X	Airplus	Air service units	87
T174Y	Airplus	Air service units	87



## Pneumatic actuation

Coding	Series	Family	Page
1200.20.04/1	1500 ECOMPACT - Accessories	ISO 21287 Compact cylinders	94
1200.20.32.F	1500 ECOMPACT - Accessories	ISO 21287 Compact cylinders	93
1200...	1200 Fixing device	ISO 6432 Microbore cylinders	26-27
1200...X	1200 Steel line Accessories	ISO 6432 Microbore cylinders	28-29
1213...	1200 Special performance	Threaded body microbore	103-104
1230...	1200 "TECNO-MIR"	ISO 6432 Microbore cylinders	10-11
1231...	1200 "TECNO-MIR"	ISO 6432 Microbore cylinders	10-11
1232...	1200 "TECNO-MIR"	ISO 6432 Microbore cylinders	10-11
1260...	1200 Threaded end caps	ISO 6432 Microbore cylinders	1-3
1260...	1260	Piston rod lock	271-272
1260...	1260	Linear control units	273-274
1260...F	1200 Steel line Accessories	ISO 6432 Microbore cylinders	25
1261...	1200 Threaded end caps	ISO 6432 Microbore cylinders	1-3
1271...	1200 Threaded end caps	ISO 6432 Microbore cylinders	1-3
1272...	1200 Threaded end caps	ISO 6432 Microbore cylinders	1-3
1273...	1200 Threaded end caps	ISO 6432 Microbore cylinders	1-3
1274...	1200 Threaded end caps	ISO 6432 Microbore cylinders	1-3
1280...	1200 Rolled end caps "MIR"	ISO 6432 Microbore cylinders	4-6
1280...X	1200 Rolled end caps "MIR-INOX"	ISO 6432 Microbore cylinders	8-9
1281...	1200 Rolled end caps "MIR"	ISO 6432 Microbore cylinders	4-6
1282...	1200 Rolled end caps "MIR"	ISO 6432 Microbore cylinders	4-6
1282...X	1200 Rolled end caps "MIR-INOX"	ISO 6432 Microbore cylinders	8-9
1291...	1200 Rolled end caps "MIR"	ISO 6432 Microbore cylinders	4-6
1292...	1200 Rolled end caps "MIR"	ISO 6432 Microbore cylinders	4-6
1293...	1200 Rolled end caps "MIR"	ISO 6432 Microbore cylinders	4-6
1294...	1200 Rolled end caps "MIR"	ISO 6432 Microbore cylinders	4-6
12X...	1200 Steel line	ISO 6432 Microbore cylinders	12-18
12X...	1200 Steel line Accessories	ISO 6432 Microbore cylinders	21-24
12XF...	1200 Steel line	ISO 6432 Microbore cylinders	20
1300...F	13... - Accessories	CNOMO-CETOP-ISO cylinders	38-39
1302...F	1315 - Accessories	ISO 15552 cylinders	70
1303...	1303	CNOMO-CETOP-ISO cylinders	30-32
1303...F	13... - Accessories	CNOMO-CETOP-ISO cylinders	34-39
1304...	1304	CNOMO-CETOP-ISO cylinders	30-32
1304...F	13... - Accessories	CNOMO-CETOP-ISO cylinders	34-39
1305...	1305	CNOMO-CETOP-ISO cylinders	30-32
1306.15	13... - Accessories	CNOMO-CETOP-ISO cylinders	33
1306.A	13... - Accessories	CNOMO-CETOP-ISO cylinders	33
1306.B	13... - Accessories	CNOMO-CETOP-ISO cylinders	33
1306.C	13... - Accessories	CNOMO-CETOP-ISO cylinders	33
1306.D	1315 - Accessories	ISO 15552 cylinders	70
1306.E	1315 - Accessories	ISO 15552 cylinders	70
1306...	1306	CNOMO-CETOP-ISO cylinders	30-32
1307...	1307	CNOMO-CETOP-ISO cylinders	30-32
1308...	1308	CNOMO-CETOP-ISO cylinders	30-32
1315...	1315 Round Tube	ISO 15552 cylinders	69-70
1319...	1319	ISO 15552 cylinders	40-42
1320.15	1330-1331-1332-1333-Accessories	Rotary actuators	216

Coding	Series	Family	Page
1320.15	1330-1331-1332-1333-Accessories	Rotary actuators	216
1320.16	1330-1331-1332-1333-Accessories	Rotary actuators	216
1320.17	1330-1331-1332-1333-Accessories	Rotary actuators	216
1320.18	1330-1331-1332-1333-Accessories	Rotary actuators	216
1320.19	1330-1331-1332-1333-Accessories	Rotary actuators	216
1320.20	1330-1331-1332-1333-Accessories	Rotary actuators	216
1320.21	13... - Accessories	CNOMO-CETOP-ISO cylinders	33
1320.21	1330-1331-1332-1333-Accessories	Rotary actuators	216
1320.22	13... - Accessories	CNOMO-CETOP-ISO cylinders	33
1320.22	1330-1331-1332-1333-Accessories	Rotary actuators	216
1320.23	13... - Accessories	ISO 15552 cylinders	49
1320.24	13... - Accessories	ISO 15552 cylinders	49
1320.A...	1330-1331-1332-1333-Accessories	Rotary actuators	216
1320.B...	1330-1331-1332-1333-Accessories	Rotary actuators	216
1320.C...	1330-1331-1332-1333-Accessories	Rotary actuators	216
1320.D...	1330-1331-1332-1333-Accessories	Rotary actuators	216
1320.E...	1330-1331-1332-1333-Accessories	Rotary actuators	216
1320.F...	1330-1331-1332-1333-Accessories	Rotary actuators	216
1320...	1320	ISO 15552 cylinders	40-42
1320...	1320 - Accessories	ISO 15552 cylinders	45
1320...	1320	Piston rod lock	269-270
1320...	1320	Linear control units	269-271
1320...F	1300 - Accessories	ISO 15552 cylinders	57-67
1320...F	1500 ECOMPACT - Accessories	ISO 21287 Compact cylinders	93-102
1320...F	1373 - ECOFLAT - Accessories	Flat cylinders	113-114
1320...F	1500 - Ecompact-S - Accessories	Compact cylinders	147
1321...	1321	ISO 15552 cylinders	40-42
1325...	1325 - Twin rod cylinders	Non rotating cylinders	105-106
1325...F	1325 - Twin rod cylinders	Non rotating cylinders	107
1326...	1325 - Twin rod cylinders	Non rotating cylinders	105-106
1330...	1330	Rotary actuators	213-215
1331...	1331	Rotary actuators	213-215
1332...	1332	Rotary actuators	213-215
1333...	1333	Rotary actuators	213-215
1345...	1325 - Twin rod cylinders	Non rotating cylinders	105-106
1346...	1325 - Twin rod cylinders	Non rotating cylinders	105-106
1348...	1348	ISO 15552 cylinders	43-44
1349...	1349	ISO 15552 cylinders	43-44
1350...	1350	ISO 15552 cylinders	43-44
1370...	1370 - ECOFLAT	Flat cylinders	108-110
1370...F	1373 - ECOFLAT - Accessories	Flat cylinders	111-112
1371...	1370 - ECOFLAT	Flat cylinders	108-110
1372...	1372 - ECOFLAT	Flat cylinders	108-110
1373...	1373 - ECOFLAT	Flat cylinders	108-110
1380.01F	1500 - EUROPE - Fixing device	Compact cylinders	143
1380...F	1300 - Accessories	ISO 15552 cylinders	57-67
1380...F	1500 ECOMPACT - Accessories	ISO 21287 Compact cylinders	95-101
1380...F	1500 - Ecompact-S - Accessories	Compact cylinders	147



Coding	Series	Family	Page
1320.16	1330-1331-1332-1333-Accessories	Rotary actuators	216
1320.17	1330-1331-1332-1333-Accessories	Rotary actuators	216
1320.18	1330-1331-1332-1333-Accessories	Rotary actuators	216
1320.19	1330-1331-1332-1333-Accessories	Rotary actuators	216
1320.20	1330-1331-1332-1333-Accessories	Rotary actuators	216
1320.21	13... - Accessories	CNOMO-CETOP-ISO cylinders	33
1320.21	1330-1331-1332-1333-Accessories	Rotary actuators	216
1320.22	13... - Accessories	CNOMO-CETOP-ISO cylinders	33
1320.22	1330-1331-1332-1333-Accessories	Rotary actuators	216
1320.23	13... - Accessories	ISO 15552 cylinders	49
1320.24	13... - Accessories	ISO 15552 cylinders	49
1320.A...	1330-1331-1332-1333-Accessories	Rotary actuators	216
1320.B...	1330-1331-1332-1333-Accessories	Rotary actuators	216
1320.C...	1330-1331-1332-1333-Accessories	Rotary actuators	216
1320.D...	1330-1331-1332-1333-Accessories	Rotary actuators	216
1320.E...	1330-1331-1332-1333-Accessories	Rotary actuators	216
1320.F...	1330-1331-1332-1333-Accessories	Rotary actuators	216
1320...	1320	ISO 15552 cylinders	40-42
1320...	1320 - Accessories	ISO 15552 cylinders	45
1320...	1320	Piston rod lock	269-270
1320...	1320	Linear control units	269-271
1320...F	1300 - Accessories	ISO 15552 cylinders	57-67
1320...F	1500 ECOMPACT - Accessories	ISO 21287 Compact cylinders	93-102
1320...F	1373 - ECOFLAT - Accessories	Flat cylinders	113-114
1320...F	1500 - Ecompact-S - Accessories	Compact cylinders	147
1321...	1321	ISO 15552 cylinders	40-42
1325...	1325 - Twin rod cylinders	Non rotating cylinders	105-106
1325...F	1325 - Twin rod cylinders	Non rotating cylinders	107
1326...	1325 - Twin rod cylinders	Non rotating cylinders	105-106
1330...	1330	Rotary actuators	213-215
1331...	1331	Rotary actuators	213-215
1332...	1332	Rotary actuators	213-215
1333...	1333	Rotary actuators	213-215
1345...	1325 - Twin rod cylinders	Non rotating cylinders	105-106
1346...	1325 - Twin rod cylinders	Non rotating cylinders	105-106
1348...	1348	ISO 15552 cylinders	43-44
1349...	1349	ISO 15552 cylinders	43-44
1350...	1350	ISO 15552 cylinders	43-44
1370...	1370 - ECOFLAT	Flat cylinders	108-110
1370...F	1373 - ECOFLAT - Accessories	Flat cylinders	111-112
1371...	1370 - ECOFLAT	Flat cylinders	108-110
1372...	1372 - ECOFLAT	Flat cylinders	108-110
1373...	1373 - ECOFLAT	Flat cylinders	108-110
1380.01F	1500 - EUROPE - Fixing device	Compact cylinders	143
1380...F	1300 - Accessories	ISO 15552 cylinders	57-67
1380...F	1500 ECOMPACT - Accessories	ISO 21287 Compact cylinders	95-101
1380...F	1500 - Ecompact-S - Accessories	Compact cylinders	147
1386.15	13... - Accessories	ISO 15552 cylinders	49
1386...	1386	ISO 15552 cylinders	46-48

Coding	Series	Family	Page
1386...F	1300 - Accessories	ISO 15552 cylinders	64
1387...	1387	ISO 15552 cylinders	46-48
1388...	1388	ISO 15552 cylinders	46-48
1390...	1390 Ecolight	ISO 15552 cylinders	50-53
1390...	1390 - Accessories	ISO 15552 cylinders	55
1390...F	1300 - Accessories	ISO 15552 cylinders	57-67
1390...F	1300 - Accessories	ISO 15552 cylinders	65
1390...F	1500 - Ecompact-S - Accessories	Compact cylinders	147
1391...	1391 Ecolight	ISO 15552 cylinders	50-53
1392...	1392 Ecolight	ISO 15552 cylinders	50-53
1393.A	AISI 316 - Accessories	ISO 15552 cylinders	74
1393.B	AISI 316 - Accessories	ISO 15552 cylinders	74
1393.C	AISI 316 - Accessories	ISO 15552 cylinders	74
1393...	AISI 316 - Steel Line	ISO 15552 cylinders	71-72
1393...F	AISI 316 - Accessories	ISO 15552 cylinders	75-80
1394...	AISI 316 - Steel Line	ISO 15552 cylinders	71-72
1396...	1396	ISO 15552 cylinders	46-48
1397...	1397	ISO 15552 cylinders	46-48
1398...	1398	ISO 15552 cylinders	46-48
1400.40...	1400	Hydraulic speed control cylinders	115-121; 126
1400.63...	1400	Hydraulic speed control cylinders	122-126
1450...	1450	ISO 15552 Hydro-Pneumatic cylinders	81-86
1463...	1463	ISO 15552 Hydro-Pneumatic cylinders	81-86
1500.20.F	1500 ECOMPACT - Accessories	ISO 21287 Compact cylinders	94
1500.AC	SA	Standard series	255
1500.DC	SA	Standard series	255
1500.H...	SA	Standard series	259
1500.U	SA	Standard series	255
1500.U/1	SA	Standard series	255
1500...	1500 Sensors	ISO 15552 cylinders	54
1500...F	1500 - Short stroke - Accessories	Compact cylinders	134-135
1500...F	1500 - EUROPE - Fixing device	Compact cylinders	140-143
1501...	1500 - Short stroke	Compact cylinders	127-128
1501...AR.	1500 - Short stroke - Accessories	Compact cylinders	133
1502...	1500 - Short stroke	Compact cylinders	129
1503...	1500 - Short stroke	Compact cylinders	130
1504...	1500 - Short stroke	Compact cylinders	131
1511...	1500 - Short stroke	Compact cylinders	128
1511...AR.	1500 - Short stroke - Accessories	Compact cylinders	133
1512...	1500 - Short stroke	Compact cylinders	129
1513...	1500 - Short stroke	Compact cylinders	130
1514...	1500 - Short stroke	Compact cylinders	131
1515...	1500 - Short stroke	Compact cylinders	132
1516...	1500 - Short stroke	Compact cylinders	132
1517...	1500 - Short stroke	Compact cylinders	132
154...	1500 ECOMPACT	ISO 21287 Compact cylinders	87-92
154...	1500 - Ecompact-S	Compact cylinders	144-146
1540...1F	6400 - Rotary actuators - Accessories	Rotary actuators	224
1540...F	1500 ECOMPACT - Accessories	ISO 21287 Compact cylinders	95
155...	1500 ECOMPACT	ISO 21287 Compact cylinders	87-92
155...	1500 - Ecompact-S	Compact cylinders	144-146
156...	1500 - EUROPE	Compact cylinders	136-138
157...	1500 - EUROPE	Compact cylinders	136-138
158...	1500 - EUROPE	Compact cylinders	136-138



Coding	Series	Family	Page
1580.H...	SR	Miniaturised series	263
1580.U...	SR	Miniaturised series	263
1580...	1580 Sensors	ISO 15552 cylinders	54; 74
1580...F	1500 - EUROPE - Fixing device	Compact cylinders	140-143
1581.HAP	ST Sensors	Rotary actuators	231
1581.HAP	ST	Miniaturised series	266
1581.U	ST Sensors	Rotary actuators	231
1581.U	ST	Miniaturised series	266
1583.DC	ST Sensors	Rotary actuators	231-232
1583.DC	ST	Miniaturised series	267
1583.HAP	ST Sensors	Rotary actuators	231-232
1583.HAP	ST	Miniaturised series	267
159...	1500 - EUROPE	Compact cylinders	136-138
1590.H...	SQ	Miniaturised series	265
1590.U...	SQ	Miniaturised series	265
1590...	Sensori 1590	Rodless cylinders	209
1595.H...	SU	Miniaturised series	264
1600.16...F	1605 - Accessories	Rodless cylinders	210-211
1600.A	1605 - Accessories	Rodless cylinders	203
1600.AC	SA	Standard series	255
1600.B	1605 - Accessories	Rodless cylinders	203
1600.DC	SA	Standard series	255
1600.H...	SA	Standard series	259
1600.U	SA	Standard series	255
1600.U/1	SA	Standard series	255
1600...F	1605 - Accessories	Rodless cylinders	204-206
1601...	1601	Cable cylinders	212
1605.16...	1605 - Ø16	Rodless cylinders	207-209
1605...	1605	Rodless cylinders	196-202
6100...	6100	Guided compact cylinders	153-160
6101...	6101	Guided compact cylinders	161-164
6110...	6110	Guided compact cylinders	165-167
6200...	6200 - Twin-rod Slide units	Slide units	178-183
6210...	6210 Through rod twin-rod Slide units	Slide units	184-188
6301...	6301 - Angular grippers	Pneumatic grippers	235-238
6302...	6302 - Angular grippers	Pneumatic grippers	239-241
6302...	6302 - Angular grippers	Pneumatic grippers	242-244
6310...	6310 - Parallel style grippers	Pneumatic grippers	245-247
6311...	6311 - Parallel style grippers	Pneumatic grippers	248-250
6312...	6312 - 3 fingers parallel style	Pneumatic grippers	251-253
6400...	6400 - Rotary actuators	Rotary actuators	217-220
6411...	6400 - Rotary actuators	Rotary actuators	221-223
6420...	6420 - Vane type rotary actuators	Rotary actuators	225-231
6500...	6500	Multimount cylinders	149-150
6600...	6600	Slide cylinders	168-175
6600...S...	6600 - Accessories	Slide cylinders	177
6600...VR	6600 - Accessories	Slide cylinders	177
6700...	6700 - Slide units	Slide units	189-195
6900...	6900	Dampers	273

Coding	Series	Family	Page
C1...	SA - Cables	Standard series	256-257
C2...	SA - Cables	Standard series	256-257
C3...	SA - Cables	Standard series	256-257
CH...	SA - Cables	Standard series	257
HS...	HS Sensors	ISO 15552 cylinders	54
HS...	SA	Standard series	260-261
LHS.P	SQ	Miniaturised series	265
LHS...	LHS Sensors	Rodless cylinders	209
LRS.U...	SQ	Miniaturised series	265
LRS...	LRS Sensors	Rodless cylinders	209
MC1	SR	Miniaturised series	263; 265; 266
MC2	SR	Miniaturised series	263; 265; 267
MC3	SR	Miniaturised series	263; 265; 268
MCH...	SA - SR - SQ - ST - Cables	Standard series	256-257; 260; 263; 265; 266; 267
MHS...	MHS Sensors	ISO 15552 cylinders	54; 74
MHS...	SR	Miniaturised series	263
MRS...	MRS Sensors	ISO 15552 cylinders	54; 74
MRS...	SR	Miniaturised series	263
RS...	RS Sensors	ISO 15552 cylinders	54
RS...	SA	Standard series	256-257
SHS...	SA	Standard series	260-261
SRS...	SA	Standard series	256-257
THR.P	ST Sensors	Rotary actuators	231-232
THR.P	ST	Miniaturised series	267
THS.P	ST Sensors	Rotary actuators	231
TRS.U	ST Sensors	Rotary actuators	231
TRS.U	ST	Miniaturised series	266



## HEADQUARTERS



**PNEUMAX**

### PNEUMAX S.P.A.

Via Cascina Barbellina, 10  
24050 Lurano (BG) - Italia  
Tel. 035/4192777  
Fax 035/4192740 - 035/4192741  
info@pneumaxspa.com  
[www.pneumaxspa.com](http://www.pneumaxspa.com)

## WORLDWIDE NETWORK

### EUROPE

#### ALBANIA

**Industrial Air Solution shpk**  
Rruga industriale Tirane Vore, km 11,  
1032 Vore Tirane  
Tel. +355 69 40 80 349  
info@iasolution.al  
[www.iasolution.al](http://www.iasolution.al)

#### AUSTRIA AND SWITZERLAND

Managed by Pneumax GmbH (Germany)

#### BELGIUM

**Pneuvano BV**  
Koralenhoeve 4  
2160, Wommelgem  
Tel. +32 3 355 32 20  
info@pneuvano.com  
[www.pneuvano.com](http://www.pneuvano.com)

#### BULGARIA

**Ulmer DM OOD**  
Adam Mizkevich Str. 4a, 1360, Sofia  
Tel. +359 (2) 9259951  
office@ulmer.bg  
[www.ulmer.bg](http://www.ulmer.bg)

#### CYPRUS

**G C V Spare Parts & Services Ltd**  
Industrial Area, Anatoniko 8086  
P.O. Box 62731, Paphos  
Tel. +357 26812444  
gcv.cy@cytanet.com.cy  
[www.gcv-parts.com](http://www.gcv-parts.com)

#### CROATIA

**ProElektronika d.o.o. - Zagabria**  
Stefanovecka 10, 10040, Zagabria  
Tel. +385 (0)1 5588 988  
info@proelektronika.hr  
[www.proelektronika.hr](http://www.proelektronika.hr)

#### ESTONIA

**Alas-Kuul AS**  
Loomäe tee 1, Lehmja küla  
75306, Rae vald Harjumaa  
Tel. +372 6593 218  
info@alas-kuul.ee  
[www.alas-kuul.ee](http://www.alas-kuul.ee)

#### FRANCE

**Pneumax France SAS**  
Z.I. NORD PARADIES 7  
Rue de Waldkirch - BP 42  
67601, Selestat CEDEX  
Tel. +33 (3) 88580450  
commercial@pneumax-france.fr  
[www.pneumax-france.fr](http://www.pneumax-france.fr)

#### GERMANY

**Pneumax GmbH**  
Tantalstraße 4  
63571, Gelnhausen  
Tel. +49 (0) 6051 9777 0  
info@pneumax-gmbh.de  
[www.pneumax.de](http://www.pneumax.de)

#### GREECE

**Hydropneumatic Hellas S.A.**  
69, Spirou Patsi Str. T.K., 118 55, Atene  
Tel. +30 (210) 3474181-2-3  
info@mitsis.com.gr  
[www.mitsis.com.gr](http://www.mitsis.com.gr)

#### UNITED KINGDOM

**Pneumax UK Ltd.**  
110 Vista Park,  
Mauretania Road  
SO16 0YS, Nursling  
Tel. +44 2380 740412  
sales@pneumax.co.uk  
[www.pneumax.co.uk](http://www.pneumax.co.uk)

#### ICELAND

**Barki E.H.F. Ltd**  
Nybylavegi 22, 200, Kópavogur  
Tel. +354 554 6499  
barkiea@islandia.is

#### LITHUANIA

**UAB "Domingos prekyba"**  
Savanoriu PR 187-4 Korp, 2053, Vilnius  
Tel. +370 5 2322231  
info@dominga.lt  
[www.dominga.lt](http://www.dominga.lt)

#### NORTHERN MACEDONIA

**DIL KOM DOOEL**  
St. Joska Jordanoski No 657500, Prilep  
Tel. +389 78244177  
export.dilkom@gmail.com  
[www.dilkom.mk](http://www.dilkom.mk)

#### MALTA

**iAutomate Limited**  
San Bernard, Marsa MRS 1332, Malta  
Tel. +356 2786 3996  
matthew@iautomate.mt  
[www.iautomate.mt](http://www.iautomate.mt)

#### NETHERLANDS

**Pneu/Tec B.V.**  
Dirk Storklaan 75, 2132 PX, Hoofddorp  
Tel. +31 (0) 235699090  
sales@pneutech.nl  
[www.pneutech.nl](http://www.pneutech.nl)

#### POLAND

**Rectus Polska SP. Z.O.O.**  
Gumna 96, 43-426, Debowiec  
Tel. +48 (33) 857 98 00  
pneumax@pneumax.pl  
[www.pneumax.pl](http://www.pneumax.pl)

#### PORTUGAL

**Portugal Pneumax Lda**  
Complexo Industrial da  
Granja Fracção H-Casarias  
2625-607, Vialonga  
Tel. +351 (219) 737390  
geral@pneumax.pt  
[www.pneumax.pt](http://www.pneumax.pt)

#### CZECH REPUBLIC

**Pneumax Automation s.r.o.**  
U Panského mlýna 240/9,  
747 06, Opava  
Tel. +420 553 760 953  
pneumax@pneumaxsro.cz  
[www.pneumaxsro.cz](http://www.pneumaxsro.cz)

#### ROMANIA

**Gica Import Export**  
Zona Industriala de Vest str. Il nr. 5,  
310491, Arad  
Tel. +40 257 259816  
comercial@gica.ro  
[www.gica.ro](http://www.gica.ro)

#### RUSSIA / CIS

**Pneumax Ltd. Moscow**  
Kommunalniy proezd, 30  
141400, Khimki  
Tel. +7 495 7393999  
mail@pneumax.ru  
[www.pneumax.ru](http://www.pneumax.ru)





**DENMARK - FINLAND  
NORWAY - SWEDEN  
(SCANDINAVIA)**

**Pneumax Scandinavia AB**  
Strandvägen 101, SE-234 31, Lomma  
Tel. +46 (40) 617 40 40  
info@pneumax.se  
[www.pneumax.se](http://www.pneumax.se)



**SERBIA**

**Hidraulika DOO**  
Cirila i Metodija 15, 15000, Šabac  
Tel. +381 15 360 090  
info@hidraulika.rs  
[www.hidraulika.rs](http://www.hidraulika.rs)

**SLOVENIA**

**Hidravlika d.o.o.**  
Medlog, 16, 3000, Celje  
Tel. +386 (3) 5453610  
info@hidravlika.si  
[www.hidravlika.si](http://www.hidravlika.si)

**SPAIN**

**Pneumax S.A.**  
Olaso Kalea, 54, 20870, Elgoibar  
Tel. +34 943 744144  
pneumax@pneumax.es  
[www.pneumax.es](http://www.pneumax.es)



**Pneumax Catalunya S.A.**

C/Riera de Vallvidrera,  
Parc. 2N. 1 Pl. Riera del Moli  
8750, Molins de Rei  
Tel. +34 (93) 680 25 30  
pneumax@pneumaxcat.com  
[www.pneumax.es](http://www.pneumax.es)



**TURKEY**

**Eteknik Otomasyon Tic. Ltd. Sti**  
Perpa Ticaret Merkezi B Blok Kat:11 No:1636 Ok-  
meydanı Sisli (Istanbul)  
Tel. +90 212 320 81 10  
recepakar@eteknik.com  
[www.eteknik.com](http://www.eteknik.com)

**UKRAINE**

**UKRTECHTRONIC LLC.**  
st. Nyzhnoyurkivska, 9, 04080, Kiev  
Tel. +38 044 500 98 48  
sales@techtronic.com.ua  
[www.techtronic.com.ua](http://www.techtronic.com.ua)

**HUNGARY**

**Szele-Tech Bt.**  
Gvadányi u. 33-39. I. em. 108., 1141, Budapest  
Tel. +36 1 401 0023  
info@szele-tech.hu  
[www.szele-tech.hu](http://www.szele-tech.hu)

**NORTH AMERICA**

**CANADA**

**Manufacture Scorpion Inc.**  
561, rue Edouard, J2G 3Z5, Granby  
Tel. +1 (450) 378-3595  
contact@mscopyon.com  
[www.manufacturescorpion.com](http://www.manufacturescorpion.com)

**USA**

**Pneumax Automation LLC**  
128 Durkee Lane, Dallas  
NC 28034 - USA  
Tel.: +1 704 215 6991  
Fax: +1 888 613 6529  
info@pneumax.us  
[www.pneumax.us](http://www.pneumax.us)



**MEXICO**

**Pneumatecna S.A. DE C.V. - Zapopan**  
Calle Volcán Popocatepetl 1844, Colli Urbano  
45070, Zapopan, Jalisco  
Tel. +52 33 31255978  
pneumatecna@yahoo.com.mx  
[www.pneumatecna.com.mx](http://www.pneumatecna.com.mx)

**CENTRAL AMERICA**

**COSTA RICA**

**PYASA Proyectos y Automatización S.A.**  
Oficentro Santa María Oficina 1A,  
50 metros Norte  
Del Hampton Inn & Suites, Alajuela  
Tel. +506 2441-5129 / 2441-5130  
info@pyasa.net  
<https://pyasa.net>

**EL SALVADOR**

**Tecni Equipos S.A. de C.V.**  
Av. Sierra Nevada, 704 Edificio CC, 2  
Colonia Miramonte, San Salvador  
Tel. (503) 2260-8293  
Tel. (503) 2261-1497  
[tecniequipos.com.vt](http://tecniequipos.com.vt)

**GUATEMALA**

**PYASA Proyectos y Automatización S.A.**  
Avenida 3era 13-30 El Rosario Ofibodegas  
San Javier zona 3 de Mixco bodega 7  
Ciudad del Guatemala  
Tel. +502 24911414  
info@pyasa.net  
<https://pyasa.net>

**NICARAGUA**

**PYASA Proyectos y Automatización S.A.**  
Plaza Maranhao, local 7, Reparto Los Robles, o  
bien, del Hotel Seminole 100 m sur,  
1/2 m al oeste  
Managua  
Tel. +505-2255-6840  
info@pyasa.net  
<https://pyasa.net>

**SOUTH AMERICA**

**ARGENTINA**

**Figli Daniele S.r.l.**  
PTE PERON 3234  
San Justo - Pcia De Bs As.  
Tel. +54 11 4484-2074  
Fax +54 11 4651-6721  
bruno@dinautomacion.com.ar

**BRAZIL**

**Pneumax Brasil**  
Rua Apucarana 211  
8301050, São José dos Pinhais  
Tel. +55 41 33987262  
diretoria@pneumaxbr.com.br  
[www.pneumaxbr.com.br](http://www.pneumaxbr.com.br)



**CHILE**

**Schultz Automatizacion e Ingenieria Ltda**  
El Retiro 1247 - Enea - Pudahuel, Santiago  
Tel. +56 (2) 4951400  
jschultz@schultzautomatizacion.cl  
[www.schultzautomatizacion.cl](http://www.schultzautomatizacion.cl)

**COLOMBIA**

**Soluciones Neumaticas S.A.S.**  
Calle. 21 #1-21, Barrio San Nicolas, Cali  
Tel. +57 (2) 4897647  
ingenieria@solucionesneumaticas.com  
[www.solucionesneumaticas.com](http://www.solucionesneumaticas.com)

**ECUADOR**

**AINSA S.A Guayaquil City**  
Av. Juan Tanca Marengo  
Km 2,5 y Agustín Freire  
EC090509, Guayaquil City  
Tel. +593-4 3712670  
info@ainsa.com.ec  
[www.ainsa.com.ec](http://www.ainsa.com.ec)

**PERU**

**Neumatec Perú S.A.C.**  
Calle General Suárez 1023,  
Miraflores, Lima 18  
Tel. +51 (1) 4442499  
ventas@neumatecperu.com  
[www.neumatecperu.com](http://www.neumatecperu.com)

**WEF Perú S.A.C.**

Jr. Dinamarca 1427,  
LIMA 01, Cercado de Lima  
Tel. +511 4255740  
oficinacentral@wefperu.com  
[www.wefperu.com](http://www.wefperu.com)

**URUGUAY**

**Secoin S.A**  
General Aguilar 1270 bis,  
Gral. Fausto Aguilar 1270,  
11800 Departamento de Montevideo  
Tel. +598 2209 3815  
ventas@secoin.com.uy  
[www.secoin.com.uy](http://www.secoin.com.uy)

**VENEZUELA**

**Sinteco Barquisimeto**  
AV.Las Industrias Km2,  
Edif. Centro de servicios  
mercantiles local 2, Barquisimeto  
Tel. +58 251 4432555  
sintecobarqto@gmail.com  
[www.sintecobarqto.com.ve](http://www.sintecobarqto.com.ve)



## WORLDWIDE NETWORK

### AFRICA

#### ALGERIA

**C.M.P.R. Sarl**  
23 Rue Lalla Fatma N'Soumeur Hassen  
Badi El-Harrach, Algeri  
Tel. +213 21 82 70 69

#### EGYPT

**Egyptian Engineering**  
Shop 6 building no 1 Jordan co.  
10th Of Ramadan City, Egitto  
Tel. +20554368385  
Fax: +20554368385  
Email: info@eefhydropneu.com  
[www.eefhydropneu.com](http://www.eefhydropneu.com)

#### GHANA

**Cemix Limited**  
34 SPINTEX ROAD-ACCRA-GHANA-WEST  
Tel. +233 0302 817030  
sales@cemixghana.com  
[www.cemixghana.com](http://www.cemixghana.com)

#### MOROCCO

**R2i TFZ**  
Ilot 87, 1er étage, Bureau 20,  
zone franche d'Exportation Tanger  
Tel. +212 539 39 10 17  
r2itfz@r2imaroc.ma  
[www.r2itfz.com](http://www.r2itfz.com)

#### TUNISIA

**L'Equipement moderne**  
86, Av. de Carthage, 1000, Tunisi  
Tel. +216 71 343844  
equipement.moderne@planet.tn  
[www.lequipementmoderne.com](http://www.lequipementmoderne.com)

### ASIA

#### SAUDI ARABIA

**Arabian Universal Establishment for Trading**  
Southern Shopping Center, P.O BOX 3105  
21471, Jeddah  
Tel. +966 26 477159  
[www.arabianuniversal.com](http://www.arabianuniversal.com)

#### CHINA

**Pneumax Pneumatic Equipments Co., Ltd.**  
No. 76, Jinma Rd., Jiufu Economic Development Zone, Jiuting Town  
201615, PRC, Shanghai  
Tel. +86 (21) 57763100  
sales@pneumaxchina.com  
[www.pneumaxchina.com](http://www.pneumaxchina.com)



#### UNITED ARAB EMIRATES

**Fine Industrial & Agri ENG. Services**  
P. O. BOX 5763, Sharja UAE  
Tel. +971 (6) 5335434  
fineinds@emirates.net.ae

#### PHILIPPINES

**Integrated Hydro-Pneumatic SYSTEMS, INC.**  
N°4 St. Thomas Avenue,  
Lopez Commercial Area  
Sucat, Parañaque City  
Tel. +632 02 820-0569  
integhps@iconex.net

#### JORDAN

**Al Sultan Company**  
for Industrial Equipment  
P.O. Box 620996  
11162, Amman  
Tel: + 962 6 4753764  
omar@alsultanco.com  
[www.alsultanco.com](http://www.alsultanco.com)

#### INDIA

**Pneumax Pneumatic**  
India Pvt. Ltd.  
D-82, Hosiery Complex, Phase-II extrn.  
201305, Noida, UP  
Tel. +91 (120) 4352560 / 61 / 62  
info@pneumax-india.com  
[www.pneumax-india.com](http://www.pneumax-india.com)



#### INDONESIA

Managed by Pneumax Singapore Pte Ltd

**PT. Mutiara Citramulia Teknindo**  
Ruko Karawaci Residence Blok A1,  
No. 17 Jl. Raya  
Legok. Bojong Nangka Kelapa Dua  
Serpong-Tangerang 15810, Banten, 15810,  
Giacarta  
Tel. +62 21 29324792  
pneumaxmct@cbn.net.id  
[www.pneumaxspa.com/ENG](http://www.pneumaxspa.com/ENG)

#### IRAN

**Ital Electro Pneumatic**  
NO. 204-2ND FLOOR-TAGHINIA  
BLDG-SOUTH SA'ADI STREET  
114715719, Teheran  
Tel. +98 (21) 33919177  
info@italpneum.com

#### ISRAEL

**Ilan & Gavish**  
Yokneam Ilit 20692  
POB 335, Soltam Site  
Tel. +972 3 9221824  
mail@ilan-gavish.com  
[www.ilan-gavish.co.il](http://www.ilan-gavish.co.il)

#### LEBANON

**Yamine Trading Company SARL**  
Boushrieh, Industrial City, P.O. Box 90 684  
Jdeideh, El Metn 1202  
2060, Beirut  
Tel. +961 1 885520  
info@yamminetrading.com  
[www.yamminetrading.com](http://www.yamminetrading.com)

### MALAYSIA

Managed by Pneumax Singapore Pte Ltd  
PSI Pneumatic Control Sdn Bhd  
4M (1) Desa Universiti Commercial Complex,  
Jalan Sungai Dua  
11700, Penang  
Tel. +60 4 6592627  
sales-psi@airdynamics.com.sg

### OMAN

**Muscat Pneumatic System & Project LLC**  
Shop # 1484, Building # 1450B,  
P.O. Box 105 PC: 120,  
Muscat, Sultanate Of Oman  
Tel. +968 24137684  
sales@muscat-pneumatic.com

### PAKISTAN

**Fluid Teknik**  
Suite 101-104 Industrial Town Plaza, Opp. Sind  
Madressah, Shahrah-e-Liaquat  
74000, Karachi  
Tel. +92 (21) 2410335  
info@fluid-technik.com.pk  
[www.fluid-technik.com.pk](http://www.fluid-technik.com.pk)

### SINGAPORE

**Pneumax Singapore Pte Ltd**  
51, Ubi Avenue 1/ 01-16,  
Paya Ubi Industrial Park  
408933, Singapore  
Tel. +65 6392 0581  
sales@pneumax.com.sg  
[www.pneumax.com.sg](http://www.pneumax.com.sg)



### SYRIA

**Al Rowad Trading**  
P.O. BOX. 12806  
Damasco  
Tel: +963 944 228 955  
alrowadtrading01@hotmail.com

### THAILAND

**Thai Agency Engineering Co. LTD**  
9 Soi Yasoop 2, 2nd-3rd Floor, Vorasin  
building, Vipavadirangsit Road, Ladyao  
10900, Chumphon  
Tel: +66 (2) 6915900  
taec@bkk.loxinfo.co.th  
[www.thai-a.com](http://www.thai-a.com)

### OCEANIA

#### AUSTRALIA

**Air & Automation Equipment Ltd.**  
3-9 Herbert Street  
2137 N.S.W., Mortlake  
Tel. +61 (2) 9743 1271  
airauto@ihug.com.au  
[www.airautomation.com.au](http://www.airautomation.com.au)

#### NEW ZEALAND

**Automation Equipment Ltd**  
26 Tawn Place  
P. O. BOX 5656, Hamilton (Pukete)  
Tel. +64 7 8490281  
sales@autoequip.co.nz  
[www.autoequip.co.nz](http://www.autoequip.co.nz)







**PNEUMAX**

**PNEUMAX S.p.A.**

Via Cascina Barbellina, 10

24050 Lurano (BG) - Italy

P. +39 035 41 92 777

[info@pneumaxspa.com](mailto:info@pneumaxspa.com)

[www.pneumaxspa.com](http://www.pneumaxspa.com)