



PNEUMAX



SMART TECHNOLOGIES AND HUMAN COMPETENCE

GROUP OVERVIEW



Pneumax Group

Smart Technologies and Human Competence

Founded in 1976, **Pneumax S.p.A.** is today one of the leading international manufacturers of components and systems for industrial automation. It is at the forefront of a **Group** comprised of **27 companies**, with **over 800 employees worldwide**.

Ongoing investment in research and development has allowed **Pneumax** to continually expand its range of standard products and customized solutions. The use of the most advanced production technologies guarantees maximum flexibility and certified quality according to international standards in different sectors.

The desire to provide the service and application skills has in turn led to the creation of 3 specific business units, dedicated to Industrial automation, process automation and the automotive sector.



International network

Through a network of subsidiaries and exclusive distributors, Pneumax is present in more than **50 countries** around the world, supporting customers in all phases of the supply process, from pre-sales application analysis to after-sales service.

- ▶ Headquarters
- Companies
- Distributors



PNEUMAX
Headquarters

8
Production
units

27
Companies

62
Distributors

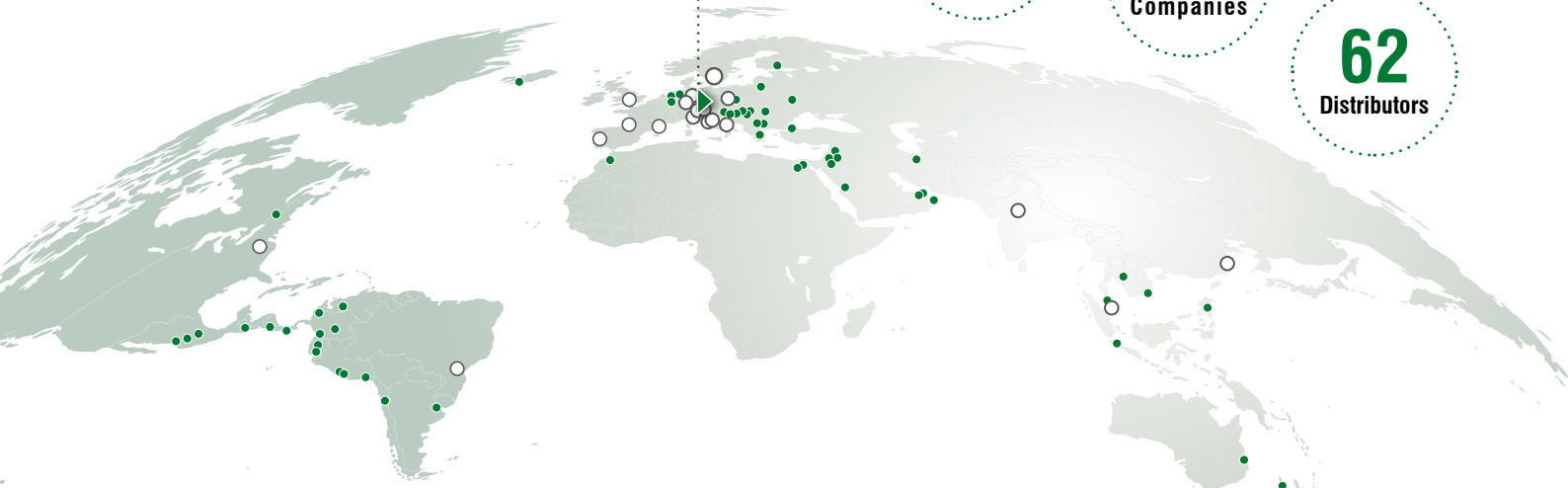

Pneumax Business Attitude

Our operating model comes from the ability to combine knowledge of the business sector with the required technical skills and an understanding of the application through collaboration with the customer. Focusing on the best suited products and technology. The most effective solutions are studied around the **TCO** (Total cost of ownership) related to the entire life cycle of the product.

BUSINESS SPECIALISTS

Application skills

- Sectors and Applications

PRODUCT SPECIALISTS

Technological knowledge

- Products and Technology



SALES ENGINEERS

Worldwide Presence

- Relationship management

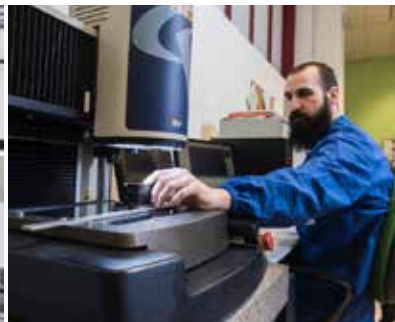



Products and technology

Technology at the service of the application

Pneumax offer the latest technology, from pneumatic automation to electric actuation and fluid control, providing an optimized solution for most applications.



PNEUMATIC TECHNOLOGY

The range of pneumatic solutions includes **actuators, valves, solenoid valves, proportional technology, fittings, handling, vacuum and air treatment components**. All combine the mechanics and electronics required for motion management and control. With optimized consumption, dimensions and functional parameters, each individual component contributes to the overall system.



ELECTRIC ACTUATION

Electric actuation is an ideal solution for applications where, in addition to reliability, it is necessary to provide high speed performance and flexibility in both the control and configuration, not only of the axes, but also of the electrical cylinders. The range includes **actuators with recirculating ball screws, in-line or parallel cylinder configurations**, all available both with or without Siemens electric motors. Customized flanges are available for mounting the customer's motors and creating solutions for a number of alternative actuators.



FLUID CONTROL

Wide range of brass and **stainless steel solenoid valves** suitable for use with air, water, steam and any other fluids compatible with the body and seals material. The solenoid valves are 2 or 3 way, normally open, normally closed, and designed for general service as either direct acting or servo assisted. Connections are available in both BSP and NPT 1/8" up to 2" and working pressures from vacuum up to 100 bar. Solenoid valves with coils enclosed in a CESI 03 and ATEX 344 certified housing are available for explosive environments.

Customized Solutions Services and Products

Customized and bespoke solutions have always been the flagship of Pneumax. With our experience and expertise as well as the use of the latest and most advanced production technology, we have the ability to offer customized products and services, designed and manufactured to meet the needs of each individual customer.

- **Mechatronic solutions**
- **Cabinets and integrated systems**
- **Special processes**
- **Customized treatments**
- **Special materials**
- **Customized testing procedures**





INDUSTRIAL AUTOMATION



This business unit manufactures components and systems for industrial automation and is the core business of **Pneumax S.p.A.** As the manufacturer of pneumatic components, Pneumax has consistently invested in extending the range of products and technologies on offer along side the associated pneumatic and electric actuation systems.

Thanks to the lean and flexible organization, Pneumax internally manages the design, machining and assembly of standard and custom products including the mechanics and electronics.

The development of solutions in line with **Industry 4.0** principles has led to the **integration of sensors and diagnostics in products** to enable monitoring, control and maintenance using digital technology.

Products:

- Valves
- Solenoid valves
- Valves and solenoid valves for fluids
- Process valves and solenoid valves
- Air service units
- Cylinders
- Pneumatic fittings
- Manipulation
- Magnetic sensors / measurement devices
- Electric actuation
- Vacuum technology

R&D drivers:

- Integrated electronics
- Components' interconnection
- Compact and ergonomic design
- Energy saving
- Real time control



Industry sectors:

- Wood machinery
- Packaging
- Assembly and robotics
- Machine tools
- Food and beverage
- Transport
- Life science





PROCESS AUTOMATION



In order to develop a range of products for use in the **'Process'** sector, Pneumax had to consider manufacturing components from materials such as Stainless Steel as well as designing products which have different operating characteristics such as the pressures used in the 'Oil & Gas' industry. This led to Pneumax creating a business unit entirely dedicated to process automation, capable of meeting the sectors specific requirements.

Pneumax are capable of manufacturing a **comprehensive range of products** which vary not only in size but also performance using materials which have to be suitable for handling gas, oil or other chemical and petrochemical products. These include solenoid valves made of Stainless Steel or aluminium, Stainless Steel air treatment units, complimented by integrated custom manifold systems.

Products:

- Air service units
- Boosters
- Spool valves and solenoid valves
- Namur valves and solenoid valves
- Flow adjusters
- Quick exhaust valves
- Non return valve
- Poppet valves

Materials:

- Stainless steel
- Aluminium

Certifications:

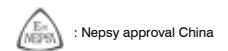
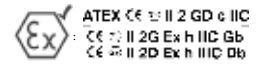

Industry sectors:

- Petrochemical
- Oil & Gas
- Power generation
- Water treatment





AUTOMOTIVE

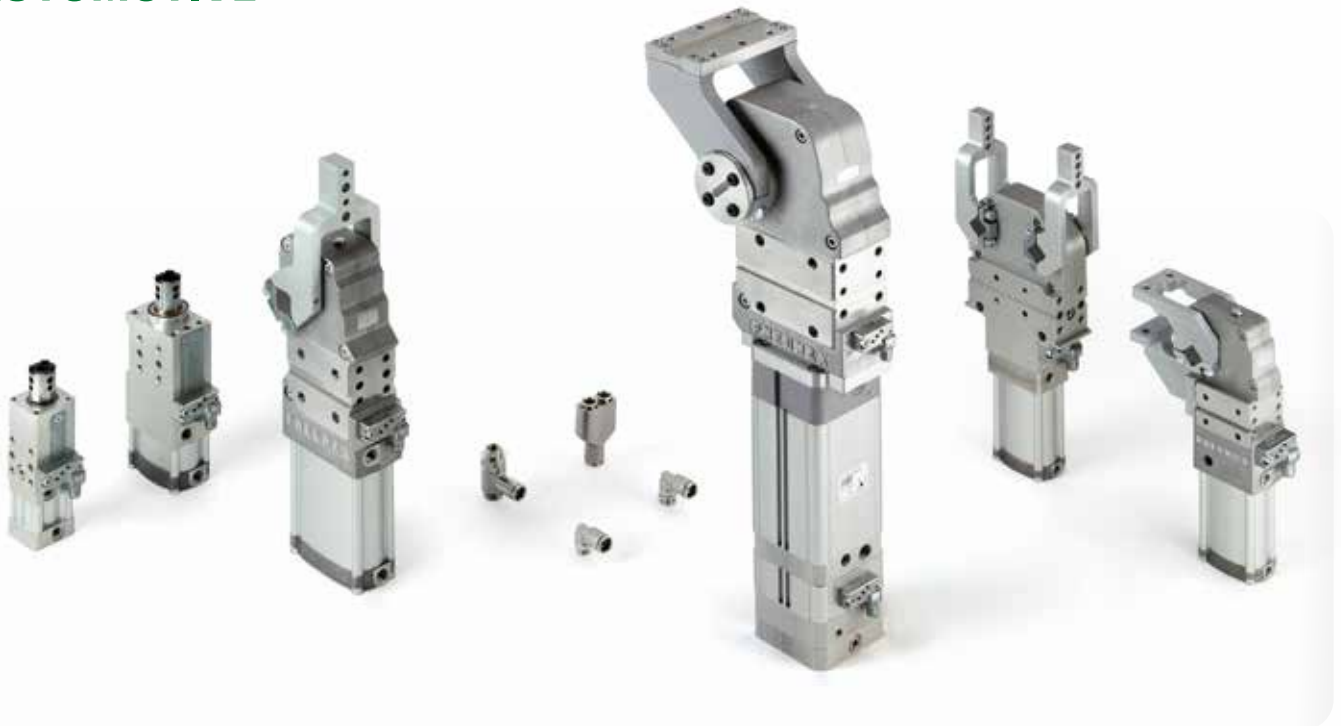

The Automotive division of Pneumax **design and manufacture a complete range of products dedicated to the production lines of the automotive sector, focusing on Body in White applications.**

Pneumax offers a comprehensive range of clamping units, pivot units, pin packages as well as grippers and complete multi-axis positioning systems. Developed by a team of specialized technicians, the product is designed to ensure maximum reliability, precision and repeatability in compliance with the latest international mounting standards.

Particular attention has been paid to energy efficiency which through patented designs provides the largest energy saving solutions available in this market.

The worldwide presence of Pneumax ensures optimized and coordinated project management: the highest level of service is provided to all of our international customers.

Products:

- Clamps
- Pin packages
- Handling products
- Power pivots
- Complementary products (fittings, sensors, tubes...)
- Accessories
- NC Locators

NC Locator

Multi-Axes Locator
for Geometric Alignments



Solutions for body in white applications

The integrated management of production processes guarantees the reliability, precision and robustness required in body in white applications (BIW).





PNEUMAX

PNEUMAX S.p.A.

Via Cascina Barbellina, 10

24050 Lurano (BG) - Italy

P. +39 035 41 92 777

info@pneumaxspa.com

www.pneumaxspa.com