

## General

The SKIP and STOP valves are pneumatically actuated 2 ways poppet valves. The SKIP valve (accelerating device) is normally open and is equipped with a supplementary regulator for maximum speed control. It must be activated to obtain speed regulation.

The STOP valve can be normally closed or normally open.

## Construction characteristics

Covers	black anodised aluminium
Barrels	bright painted drawn steel
Rod	C43 chromed steel
Tie rods	plated zinc steel
Piston	aluminium
Waterproof seals	NBR rubber
Piston seal	FPM
Rod seal	PUR
Regulators group	brass
Skip and stop valves	black anodised aluminium
Circuit oil	hydraulic with viscosity 2.9° E at 50°C (viscosity index minimum 118)
Bore	40 mm and 63 mm diameter

## Technical characteristics

Max connecting load	600 kg (Ø40) -1200 Kg (Ø63)
Min. and max. speed	60 - 10000 mm/min.
Working temperature	-5°C - +70°C
Minimum pressure for the actuation of skip and stop valves	4 bar

"Attention: Dry air must be used for application below 0°C"

## Standard strokes

50 - 100 - 150 - 200 - 250 - 300 - 350 - 400 - 450 - 500 mm  
minimum stroke for type 1400.stroke.03.05 and 1400.stroke.03.06, 150 mm.

**Important:** For heavier load we have available the hydraulic speed control check cylinders of 63 mm diameter suitable to withstand loads up to 1200 kg. For more information please contact our technical department.

### Maintenance

The speed control check is a closed system and there are no external factors that can adversely affect its function. Care however, has to be exercised not to allow the hydraulic fluid level to drop below the minimum indicated on the auxiliary tank. Should this occur, cavitation, or worse, an air pocket would result causing erratic control. Additional fluid should be put in exclusively through a unidirectional valve by means of an appropriate syringe (such as our code number 1400.99.01). Excess fluid will be expelled through a vent into an appropriate container. It is necessary to completely disassemble the regulator and be sure to bleed the system to eliminate air pockets. We suggest that you create a vacuum before beginning to refill. This can be done with a small unidirectional valve turned up and repeatedly loaded with a syringe. The rod must be manually actuated successively releasing air through the valve using a small and pointed instrument.

### Functional schematics

#### Outward Stroke Control

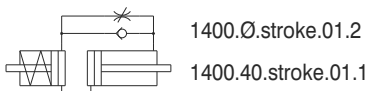

1400.Ø.stroke.01.2  
 1400.40.stroke.01.1

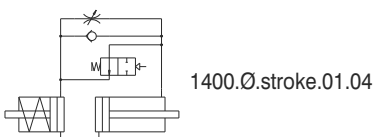

1400.Ø.stroke.01.04

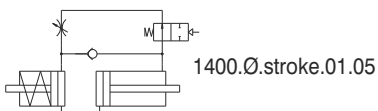

1400.Ø.stroke.01.05

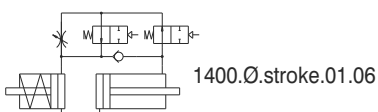

1400.Ø.stroke.01.06

#### Inward Stroke Control

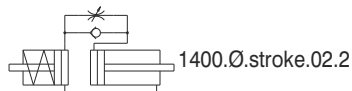

1400.Ø.stroke.02.2

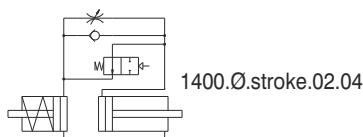

1400.Ø.stroke.02.04

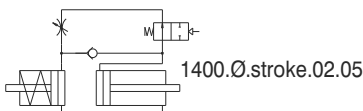

1400.Ø.stroke.02.05

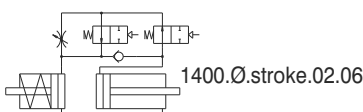

1400.Ø.stroke.02.06

#### Inward & Outward Stroke Control

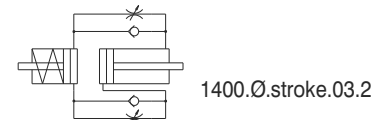

1400.Ø.stroke.03.2

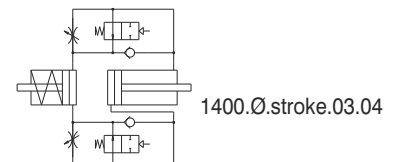

1400.Ø.stroke.03.04

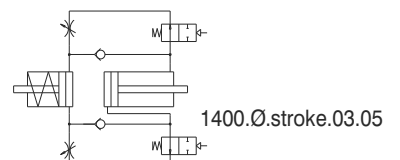

1400.Ø.stroke.03.05

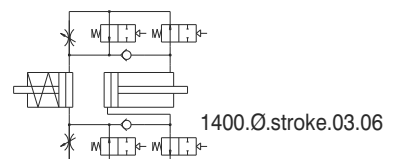

1400.Ø.stroke.03.06

**Regulation on the outward stroke - Tank in line**

Ordering code

**1400.40.stroke.01.1**



Weight gr.1450 + gr. 300 every 50 mm. stroke

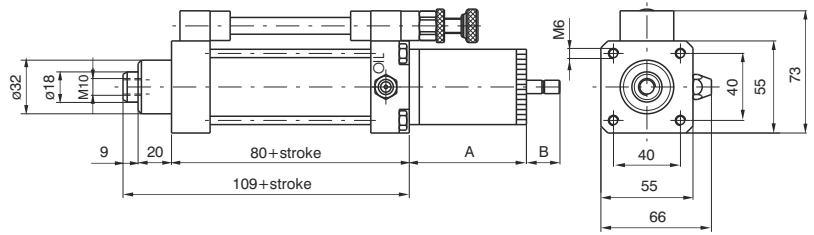

Strokes	A	B max.
< 75	78	30
75 - <150	102	45
150 - <250	127	60
250 - <350	187	90
350 - <500	202	120

**Regulation on the outward stroke - Lateral tank**

Ordering code

**1400.40.stroke.01.2**

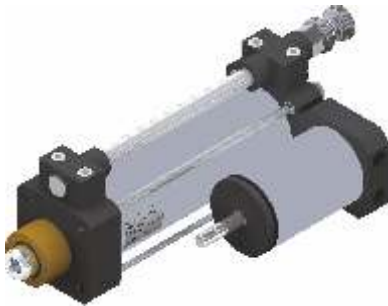

Weight gr. 1530 + gr. 300 every 50 mm. stroke

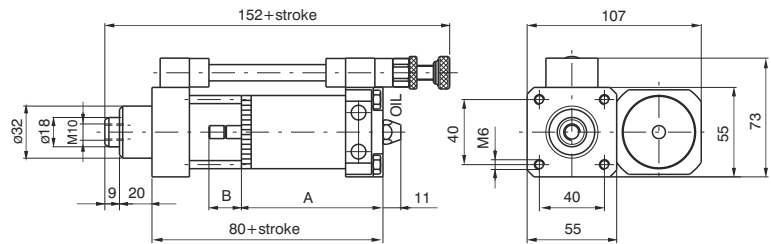

Strokes	A	B max.
< 75	93	30
75 - <150	118	45
150 - <250	143	60
250 - <350	183	90
350 - <500	218	120

**Regulation on the inward stroke**

Ordering code

**1400.40.stroke.02.2**



Weight gr. 1530 + gr. 300 every 50 mm. stroke

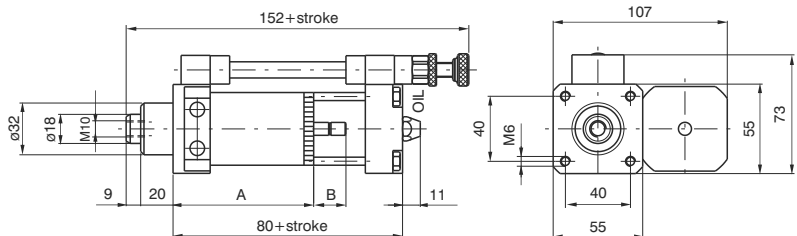

Strokes	A	B max.
< 75	93	30
75 - <150	118	45
150 - <250	143	60
250 - <350	183	90
350 - <500	218	120

**Regulation in both directions**

Ordering code

**1400.40.stroke.03.2**



Weight gr. 1870 + gr. 300 every 50 mm. stroke

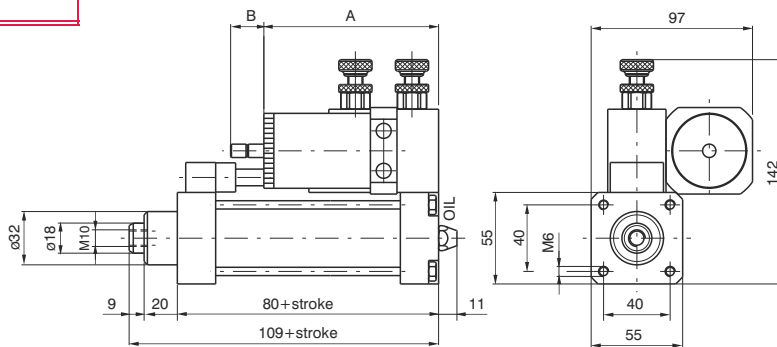

Attention: Minimum stroke=150mm when fitted in tandem (parallel or in-line) with 1319-1320-1321 cylinders series Ø80mm or Ø100mm.

Strokes	A	B max.
< 75	110	30
75 - <150	135	45
150 - <250	160	60
250 - <350	200	90
350 - <500	235	120

**Regulation on the outward stroke with skip (Acceleration valve)**

Ordering code

**1400.40.stroke.01.04**



Weight gr. 1670 + gr. 300 every 50 mm. stroke

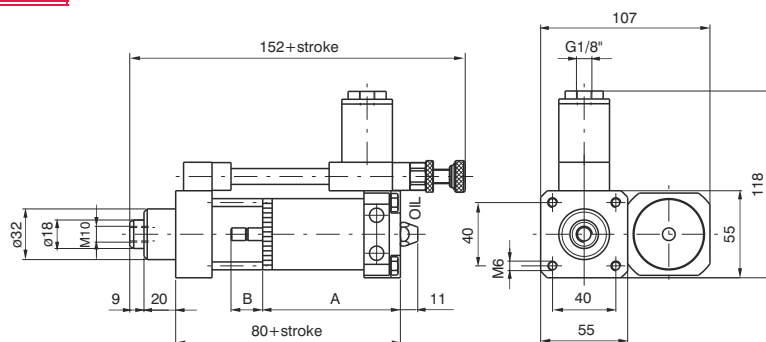

Strokes	A	B max.
< 75	93	30
75 - <150	118	45
150 - <250	143	60
250 - <350	183	90
350 - <500	218	120

**Regulation on the outward stroke with stop (Stop valve)**

Ordering code

**1400.40.stroke.01.05**

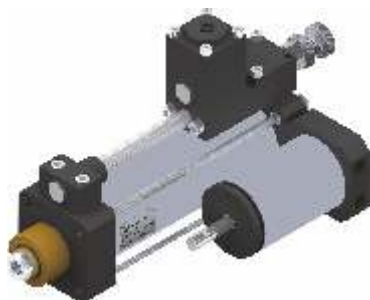

Weight gr. 1710 + gr. 300 every 50 mm. stroke

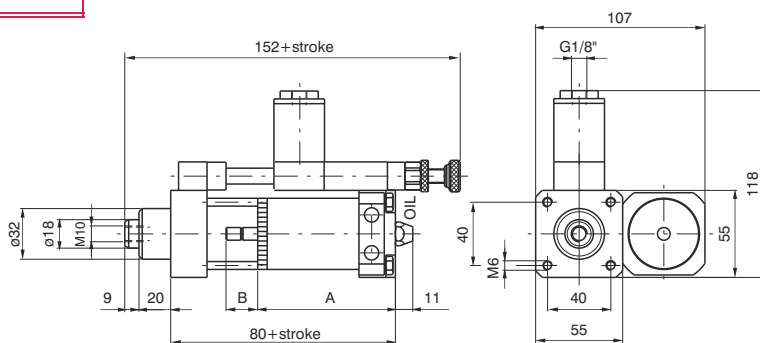

Strokes	A	B max.
< 75	93	30
75 - <150	118	45
150 - <250	143	60
250 - <350	183	90
350 - <500	218	120

**Regulation on the outward stroke with skip and stop**  
(Acceleration and stop valves)

Ordering code

**1400.40.stroke.01.06**



Weight gr. 1830 + gr. 300 every 50 mm. stroke

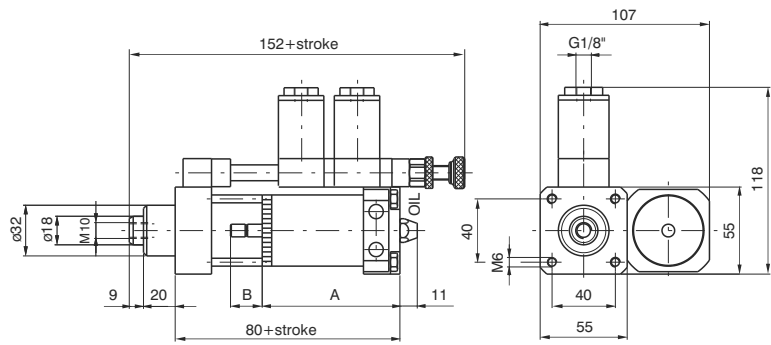

Strokes	A	B max.
< 75	93	30
75 - <150	118	45
150 - <250	143	60
250 - <350	183	90
350 - <500	218	120

**Regulation on the inward stroke with skip**  
(Acceleration valve)

Ordering code

**1400.40.stroke.02.04**



Weight gr.1670 + gr. 300 every 50 mm. stroke

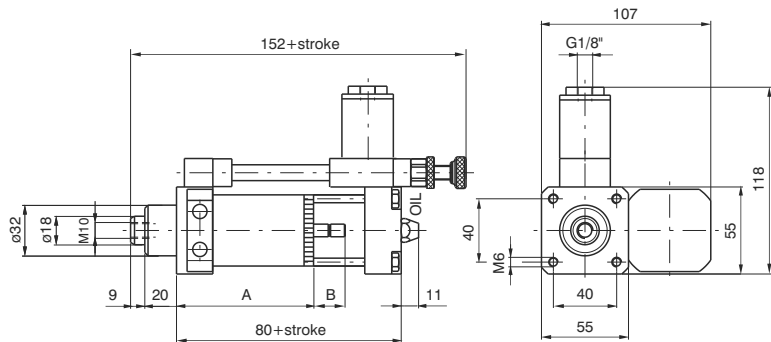

Strokes	A	B max.
< 75	93	30
75 - <150	118	45
150 - <250	143	60
250 - <350	183	90
350 - <500	218	120

**Regulation on the inward stroke with stop**  
(Stop valve)

Ordering code

**1400.40.stroke.02.05**



Weight gr. 1710 + gr. 300 every 50 mm. stroke

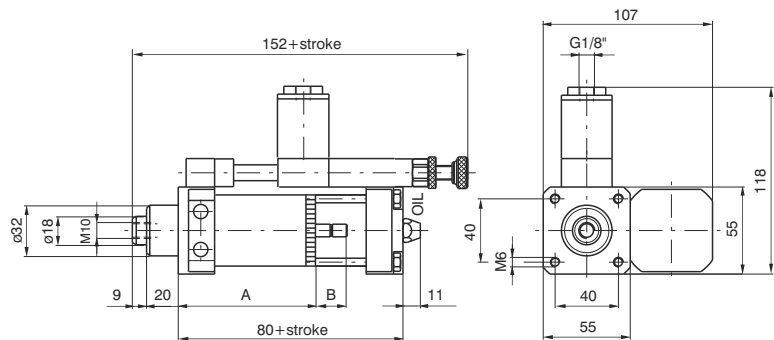

Strokes	A	B max.
< 75	93	30
75 - <150	118	45
150 - <250	143	60
250 - <350	183	90
350 - <500	218	120

4

**Regulation on the inward stroke with skip and stop**  
(Acceleration and stop valves)

Ordering code

**1400.40.stroke.02.06**



Weight gr. 1830 + gr. 300 every 50 mm. stroke

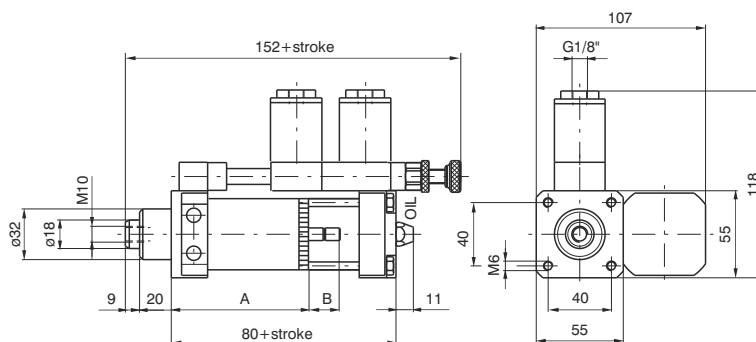

Strokes	A	B max.
< 75	93	30
75 - <150	118	45
150 - <250	143	60
250 - <350	183	90
350 - <500	218	120

**Regulation in both directions with skip**  
(Acceleration valves in both directions)

Ordering code

**1400.40.stroke.03.04**

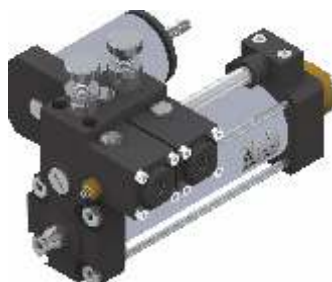

Weight gr. 2110 + gr. 300 every 50 mm. stroke

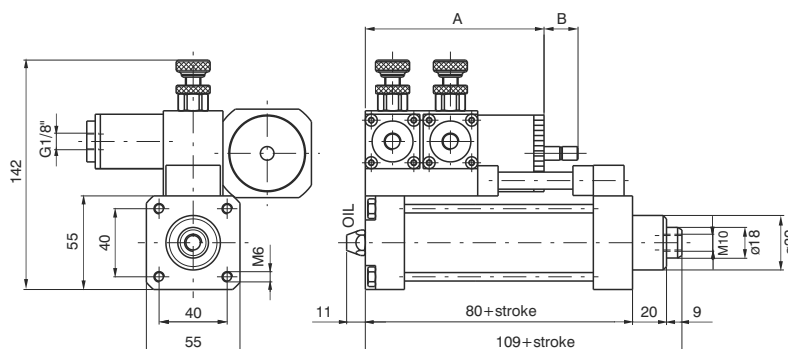

Attention: Minimum stroke=150mm when fitted in tandem (parallel or in-line) with 1319-1320-1321 cylinders series Ø80mm or Ø100mm.

Strokes	A	B max.
< 75	110	30
75 - <150	135	45
150 - <250	160	60
250 - <350	200	90
350 - <500	235	120

**Regulation in both directions with stop**  
(Stop valves in both directions)

Ordering code

**1400.40.stroke.03.05**



**Min. stroke 150 mm**

Weight gr. 2390 + gr. 300 every 50 mm. stroke

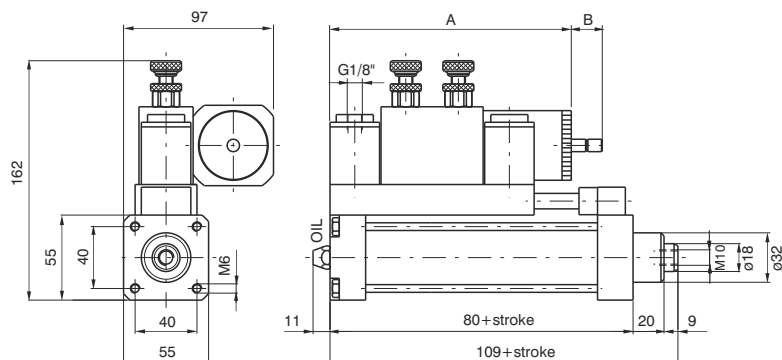

Strokes	A	B max.
150 - <250	197	60
250 - <350	237	90
350 - <500	272	120

**Regulation in both directions with skip and stop**  
(Acceleration and stop valves in both directions)

Ordering code

**1400.40.stroke.03.06**

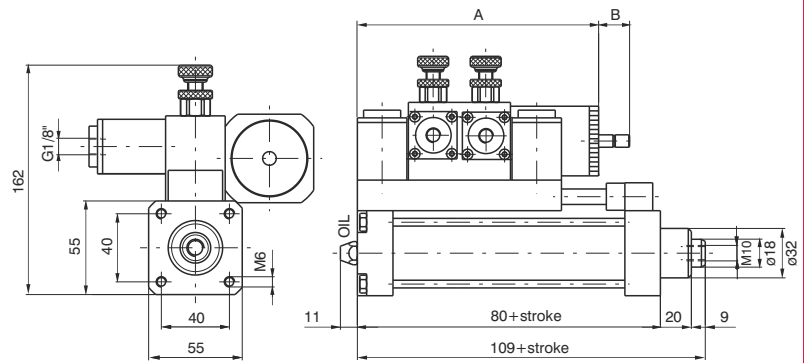
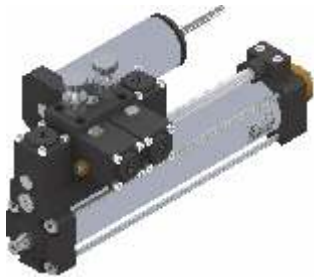

**Min. stroke 150 mm**  
Weight gr. 2630 + gr. 300 every 50 mm. stroke

Strokes	A	B max.
150 - < 250	197	60
250 - < 350	237	90
350 - < 500	272	120

**Regulation on the outward stroke – Lateral tank**

Ordering code

**1400.63.stroke.01.2**

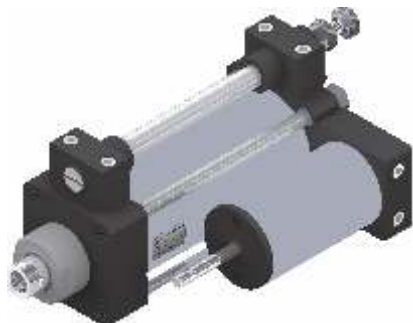

Min. stroke 75 mm  
Weight gr. 2950 + gr. 850 every 50 mm. stroke

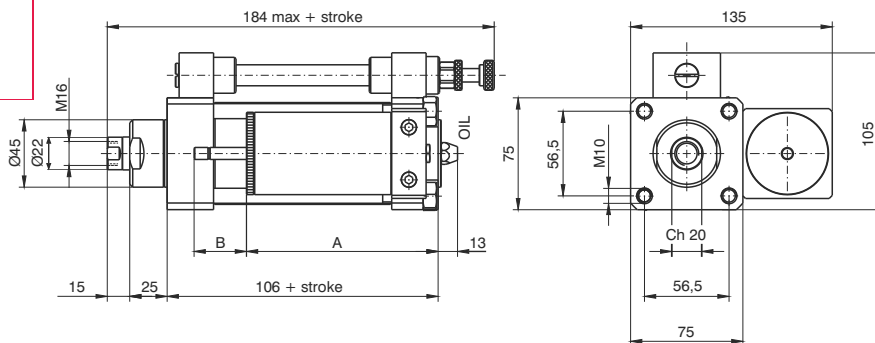

Strokes	A	B max
≥75 - <150	128	50
≥150 - <250	188	80
≥250 - <350	238	100
≥350 - <450	298	130
≥450 - ≤600	358	160

**Regulation on the inward stroke**

Ordering code

**1400.63.stroke.02.2**



Min. stroke 75 mm  
Weight gr. 2950 + gr. 850 every 50 mm. stroke

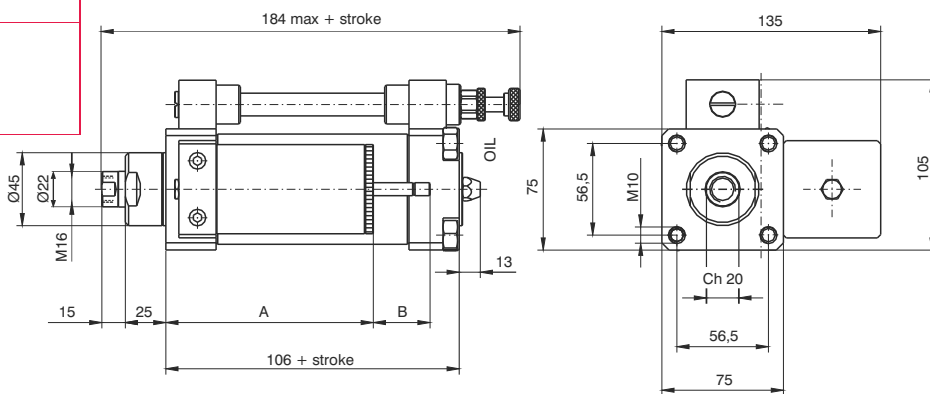

Strokes	A	B max
≥75 - <150	128	50
≥150 - <250	188	80
≥250 - <350	238	100
≥350 - <450	298	130
≥450 - ≤600	358	160

**Regulation in both directions**

Ordering code

**1400.63.stroke.03.2**

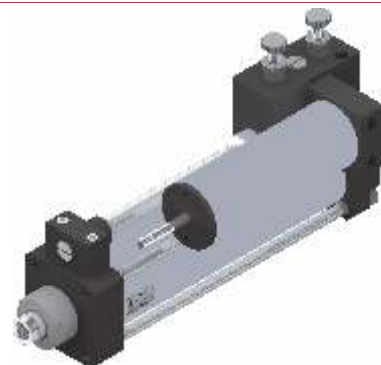

Min. stroke 100 mm  
Weight gr. 3600 + gr. 850 every 50 mm. stroke

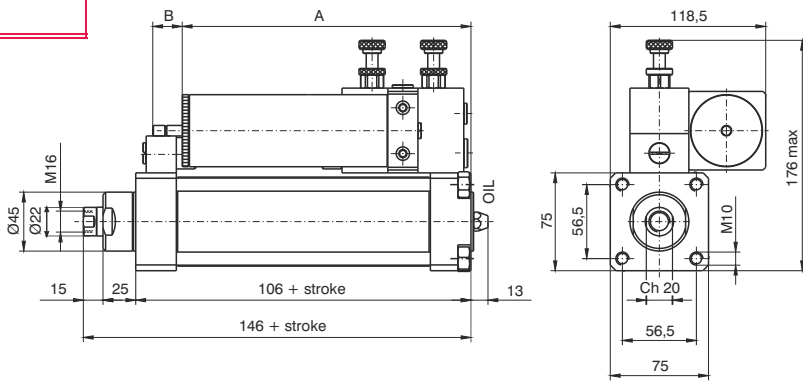

Strokes	A	B max
≥100 - <150	160	50
≥150 - <250	220	80
≥250 - <350	270	100
≥350 - <450	330	130
≥450 - ≤600	390	160

4







**Regulation in both direction with skip**  
(Accelerations valve in two directions)

Ordering code

**1400.63.stroke.03.04**

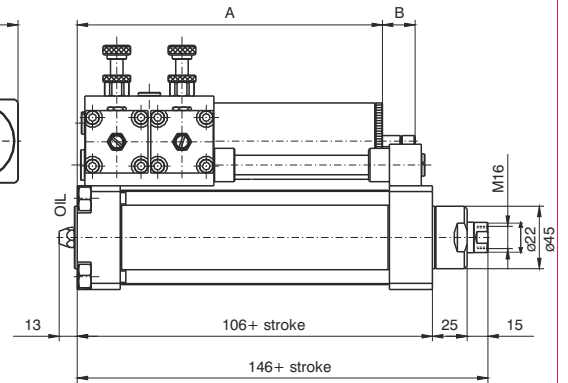
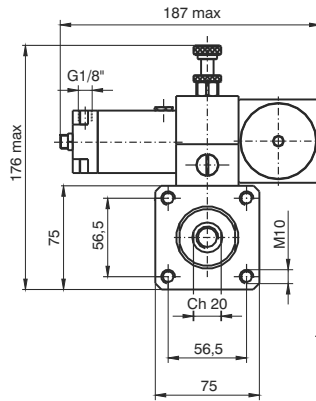
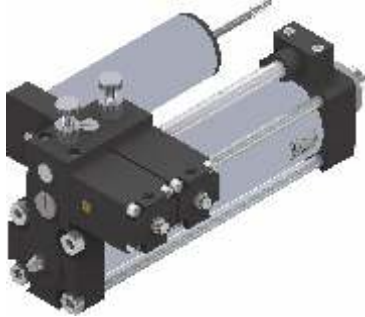

Strokes	A	B max
≥100 - <150	160	50
≥150 - <250	220	80
≥250 - <350	270	100
≥350 - <450	330	130
≥450 - ≤600	390	160

Min. stroke 100 mm  
Weight gr. 4100 + gr. 850 every 50 mm. stroke

**Regulation in both direction with stop**  
(Stop valves in two directions)

Ordering code

**1400.63.stroke.03.05**

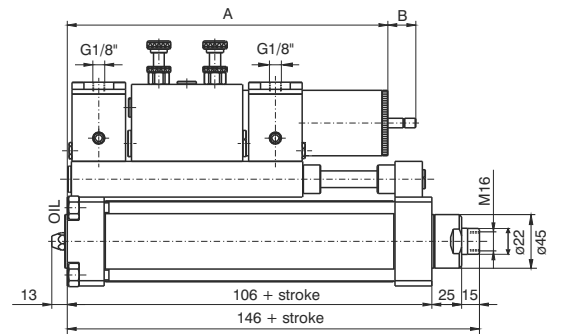
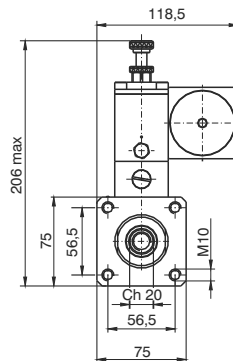
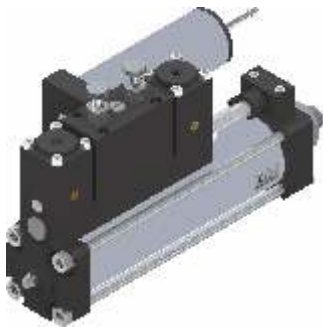

Strokes	A	B max
≥200 - <250	269	80
≥250 - <350	319	100
≥350 - <450	379	130
≥450 - ≤600	439	160

Min. stroke 200 mm  
Weight gr. 4850 + gr. 850 every 50 mm. stroke

**Regulation in both direction with skip and stop**  
(Acceleration and stop valves in two directions)

Ordering code

**1400.63.stroke.03.06**

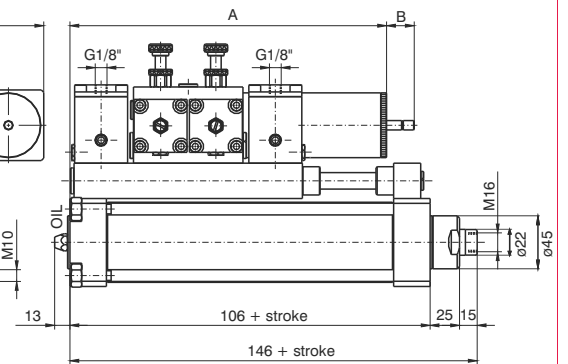
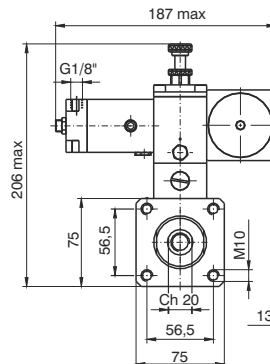
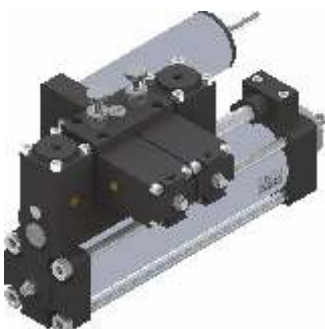

Strokes	A	B max
≥200 - <250	269	80
≥250 - <350	319	100
≥350 - <450	379	130
≥450 - ≤600	439	160

Min. stroke 200 mm  
Weight gr. 5400 + gr. 850 every 50 mm. stroke

4

**Dimensional releases and power supply positions with N.C. stop valves**

Ordering code

- 1400.Ø.stroke.01.07 regulation on the outward stroke + stop N.C.
- 1400.Ø.stroke.01.08 regulation on the outward stroke + skip + stop N.C.
- 1400.Ø.stroke.02.07 regulation on the inward stroke + stop N.C.
- 1400.Ø.stroke.02.08 regulation on the inward stroke + skip and stop N.C.
- 1400.Ø.stroke.03.07 regulation in both directions + stop N.C.
- 1400.Ø.stroke.03.08 regulation in both directions + skip + stop N.C.

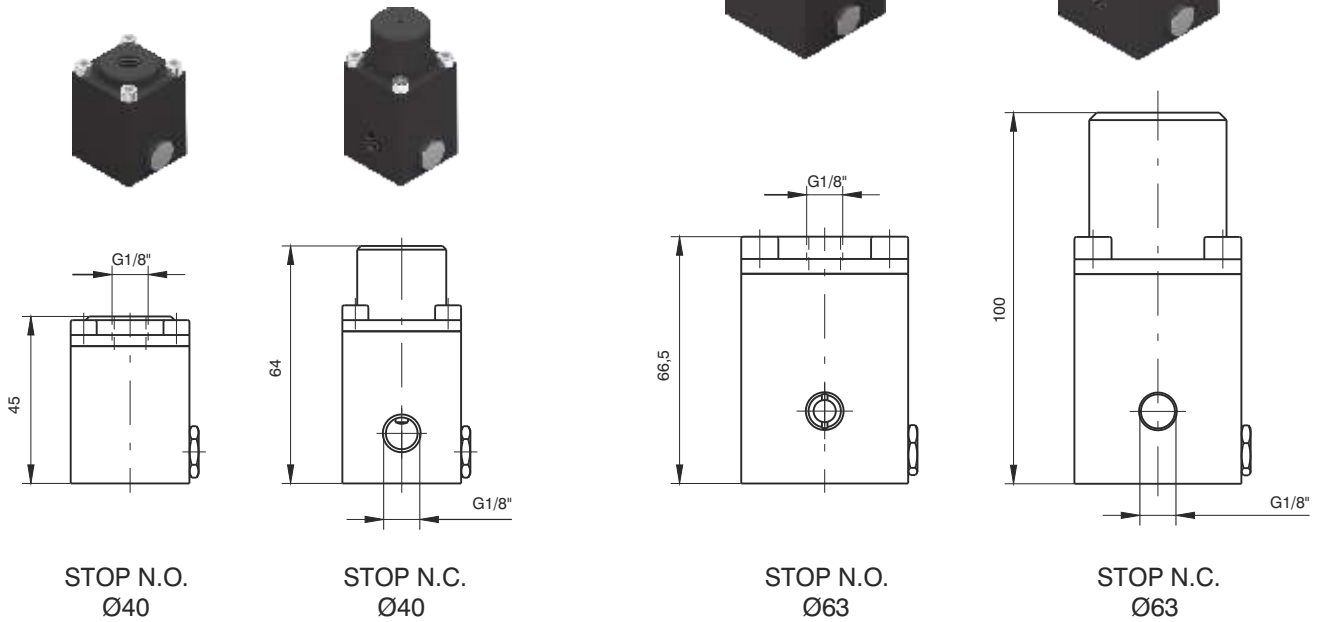

**Hydraulic fluid refill syringe**

Ordering code

1400.99.01



Weight gr. 630

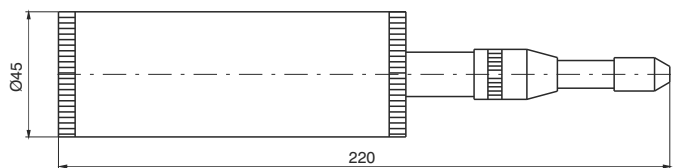

**Oil for hydraulic and pneumatic circuits**

Ordering code

**PNEUMOIL 01**  
 (1 litre cans)

This oil is suitable to lubricate pneumatic circuits and also to refill hydraulic speed control tanks. It is completely compatible with our seals.