



07 - Valves and solenoid valves

- Basic principles, working diagram
- Flow rate curves

GENERAL INFORMATION

In pneumatic applications the valve is the component that manages the compressed air, diverting and regulating the flow.

It is possible to distinguish three main categories:

- **logic elements**: block or redirect the compressed air flow depending on requirements (e.g. logic elements such as OR & AND)
- **regulation valves**: adjust the compressed air flow or pressure **depending on** requirements (e.g. flow regulators)
- **distribution valves** : redirect the compressed air flow without affecting flow rate or pressure.

Distribution valves are made by two main parts: a functional part that physically diverts the air flow (the main **body**), and a control part (the **operator**) that actuates the main valve and interfaces between the operator and the powersource (such as an actuator).

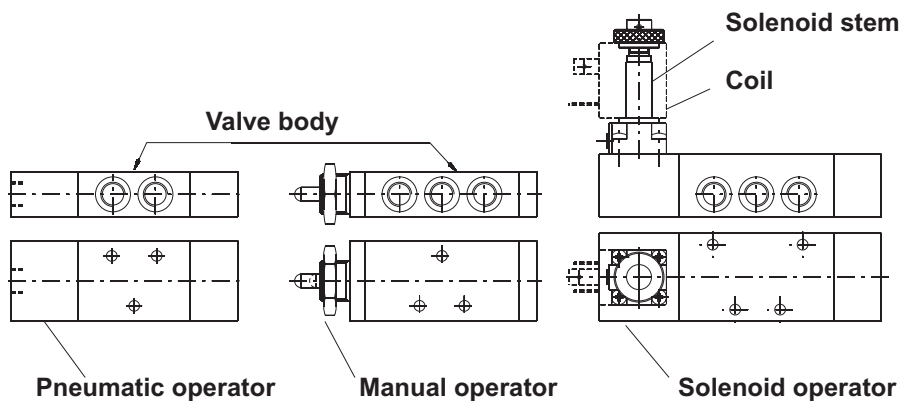

VALVE BODY

This is the functional part of the valve and includes the air connections, the mounting holes, and the moving parts needed to divert the air flow.

Two main constructive systems are available: poppet system and spool system.

Poppet system

This principle is based on two rubber poppets which move inside the valve main body and directly seal on the inner bore section .

Advantages

- the moving parts only travel short distances: fast response times
- Limited pressure drop
- large air passage sections: high flow rate

Disadvantages

- only available in monostable configuration: the control signal must stay on during operation: repositioning can only be achieved via a spring
- unbalanced system; pressure acts directly on the poppet and therefore requires strong springs to counteract it, as a consequence minimum working pressure is high.
- 5/3 function not available

Spool system

This principle is based on the spool which moves inside the seals which are fixed in the valve body. The spool is profiled so that during the movement it opens and closes air passages.

Advantages

- easy to assemble and maintain
- 5/3 functions available
- compact dimensions
- Possibility of using different type of operators on the same valve body
- Possibility of assembly on manifolds

Disadvantages

- moving parts have to travel longer distances: longer response times
- smaller air passages / lower flow rate

Various valve functions are available depending on the valve type. Listed below are some examples of the spool system.

2/2 - 2 ways 2 positions

2 threaded connections (supply and consumption no exhaust)

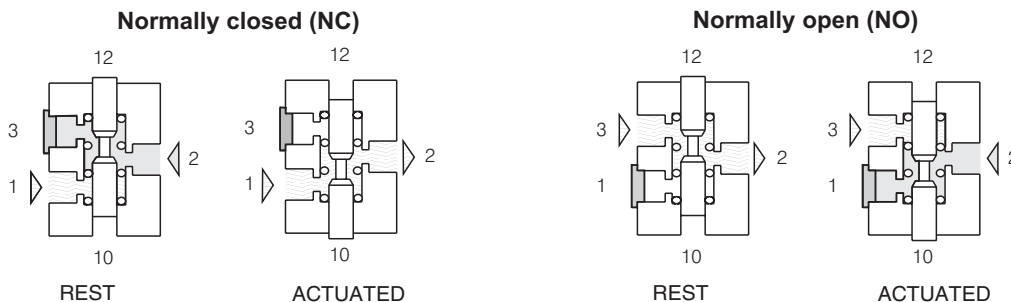

3/2 - 3 ways 2 positions

3 threaded connections (supply, outlet and exhaust)

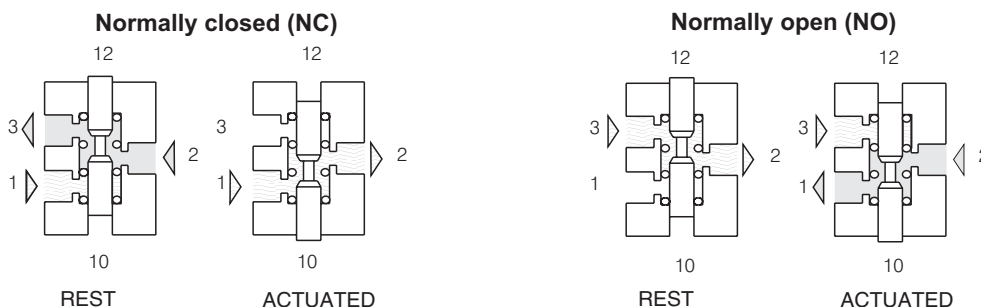

5/2 - 5 Ways 2 positions

5 threaded connections (supply , outlets, and exhausts)

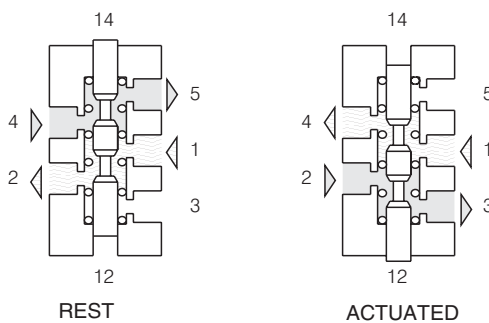

5/3 - 5 ways 3 positions

5 threaded connections (supply, outlets and exhausts)

Closed centers (CC) (rest condition: all ports closed)

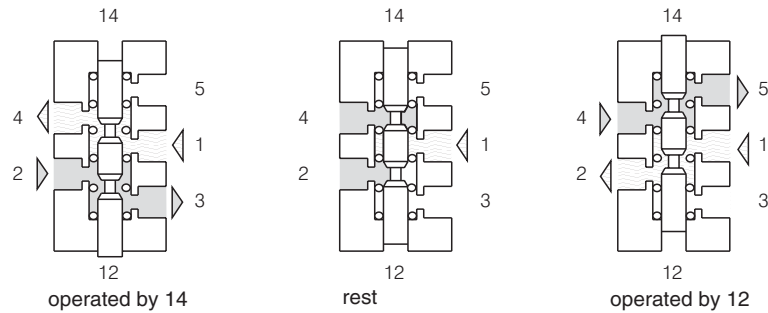

Open centers (CA) (rest conditions: port 1 closed, port 4 connected to port 5 and port 2 connected to port 3)

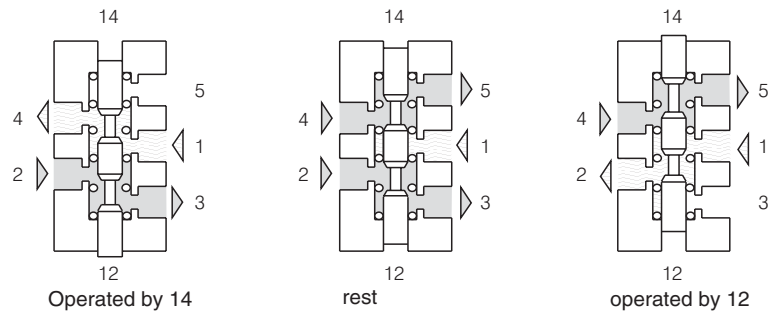

Pressurised centers (CP) (rest conditions: port one connected to 2 and 4 ,connections 5 and 3 closed)

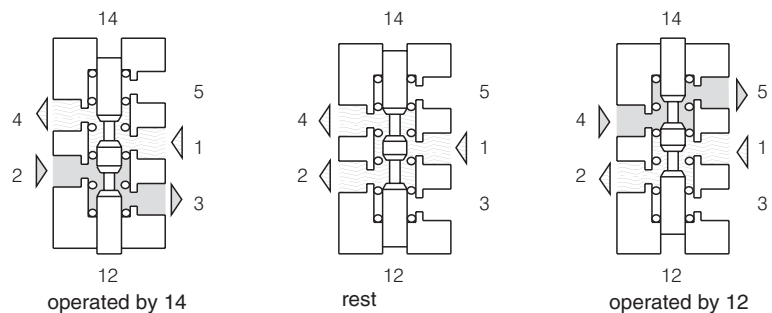

OPERATORS

The part dedicated to the control of the valve and can be used to actuate (switch) the valve or to reposition it (return the valve into the rest position) .

If the operator is manually or mechanically piloted we are talking about a valve , if it is electrically piloted we are talking about a solenoid valve.

Manual/mechanical operators

Include lever, rollers, buttons, pedals etc.... And act directly on the valve internal air distribution system (spool).

Pneumatic operators

Normally used when it is not possible to directly operate the valve; it comprises a piston which, upon receipt of an air signal, operates the valve internal air distribution system (spool) .

Electropneumatic operators

These operators transform an electrical signal into a pneumatic signal.

MONOSTABLE AND BISTABLE VALVES

Depending on the number of signals needed to operate them, valves can be classed as monostable or bistable

Monostable valves and solenoid valves: only require one external signal to operate.

On these valves the repositioning operator is unstable and does not require an external signal to switch; reset is automatic as soon as the opposing signal is removed.

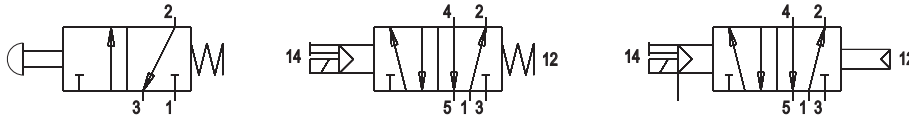

The most common unstable operators are mechanical (spring) or pneumatic (differential). The first is simply a spring that moves the spool longitudinally. The second is based on a piston which has a smaller diameter than the opposite pneumatic operator and therefore generates a smaller force. From the pneumatic symbols shown below when the signal 12 is not present the valve switches back to the rest position.



Bistable valves and solenoid valves: require two external signals in order to operate. These are valves with stable operators, such as pneumatic or 2 position buttons, which remain in position until the opposite signal is received.

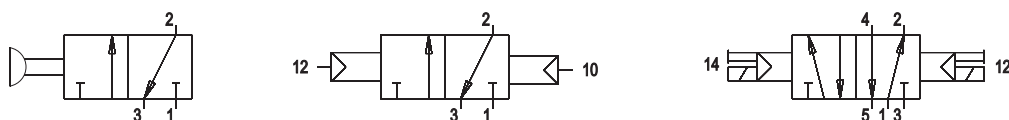

SOLENOID VALVES

Directly operated solenoid valves: these valves directly control the compressed air flow from the inlet to the outlet port and can also be defined as poppet valves. The construction is based on a hollow stem, normally made of brass or stainless steel, which is fitted at one end with a fixed plunger. Inside the stem there is a moving plunger which also carries the poppets, which is moved by the magnetic field generated by the solenoid which fits onto the stem's outer diameter. The fixed plunger is normally made of a low magnetically retentive steel which acts as a magnetic field intensifier; on applications with AC current the plunger is fitted with a copper ring called displacement ring, which helps to reduce vibrations generated by this type of current.

These solenoid valves are normally equipped with an additional manual override which can be used to activate the valve at any time (for example during maintenance or inspection) and can only be 2/2 or 3/2 (normally open or normally closed)

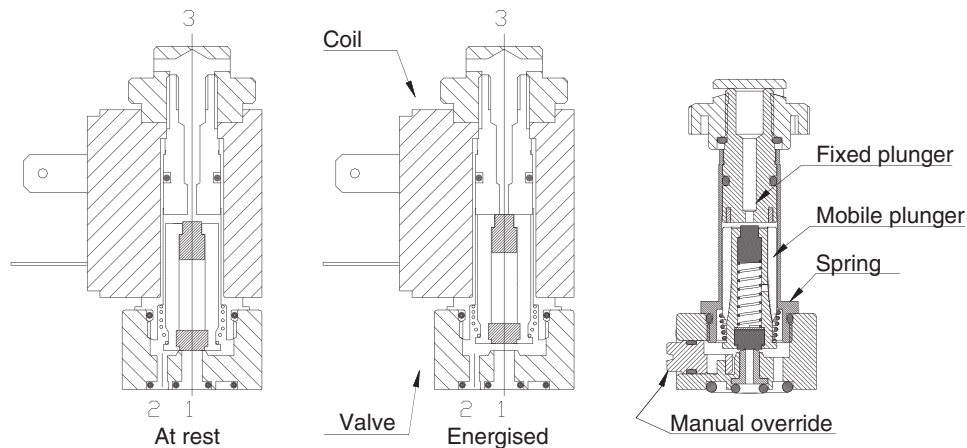

Indirectly operated valves: these valves are fitted with an indirectly operated valve which upon receipt of an electric signal, actuates a pneumatic operator.

It is possible to distinguish two main categories:

- **servo assisted** (internal feeding): the operator receives the air supply directly from the valve supply port "1"; when the solenoid is activated the air passes from the valve port "1" into the pneumatic operator that actuates the valve.

The valve supply pressure is the same as the operator pressure.

- externally supplied: basic working principle common to the servo assisted version but with the operator externally fed.

The valve and operator working pressure can be different.

TERMS

Minimum switching pressure: indicates the minimum pressure needed to switch the valve, below that value the valve does not operate.

Minimum switching force: for mechanically operated indicates the minimum mechanical or manual force needed to switch the valve.

Maximum working pressure: is the maximum pressure value at which the pneumatic device can operate in safe conditions

Nominal orifice size: correspond to the connection minimum passage size.

Minimum and maximum temperature: indicates the temperature range within which the component can operate safely